Description

Hardware Commissioning



DARC SYSTEM

DIGITAXISREGULATION CONTROLLE (CAN and Profibus-DP)

Version 1.01

DARC SYSTEM

Hardware Commissioning

Safety information :

These operating instructions / this service handbook may not be copied or its contents may not be used by or passed on to third persons without explicit permission.

The legal acquisition of this manual and the hard- and software components belonging to it permit its usage only in accordance with the contractual conditions. Without prior written permission neither the manual nor the hard- and software nor parts of them may be copied or imitated and/or made available to third parties.

All rights are reserved by

ferrocontrol Steuerungssysteme GmbH & Co.

You are only entitled to use the hardware and the documentation if you have obtained the DARC system from ferrocontrol and if you have been granted a commission number for this system by ferrocontrol. If so, you can receive telephone help and information about updates.

This manual and the hardware were produced and exhaustively tested with the greatest of care, whereby all parts were found to be correct and reliable. Nevertheless, it cannot be guaranteed that the DARC system or the manual do not contain any errors. ferrocontrol cannot be held either legally or otherwise responsible for errors or omissions or their results in any way.

In particular, we do not assume any responsibility for damage and operational defects caused by:

- disregard for the operational instructions
- unauthorized alterations to the DARC system
- operating errors
- improper tasks with and on the DARC system

We are always grateful for information about mistakes and for recommendations.

Guarantee claims must be addressed to ferrocontrol immediately the error or fault has been discovered.

The guarantee becomes null and void if:

- the DARC system is not used for its designed purposes
- improper tasks are carried out with or on the DARC system

Should the information supplied be insufficient or should any particular problems arise that are not documented in this manual, you can request further information from:

ferrocontrol Steuerungssysteme GmbH & Co.

Bodelschwinghstraße 20

D-32049 Herford

Germany

Telephone: 05221/966-0

Telefax: 05221/966-173

In most cases the software and hardware names used in this manual are also registered trade marks and are therefore subject to legal regulations.

The DARC system as described in the following is a resource for use in heavy-current plants and may only be used in accordance with the relevant regulations.

These include, for example:

- Use of the DARC system as an electronic drive regulator for controlling and regulating variable-speed, permanently energized synchronic servo-motors with resolver feedback.
- The DARC system is built into switching cabinets and control boxes for drive systems.
- Because of the earth potential import of the radio interference suppression filter, the CE-typical drive systems are not suitable for connection to IT systems (systems without import to earth potential).
- It is not to be used as a household appliance but only for industrial purposes in drive systems.
- The DARC drive system itself is not a machine as defined by the EU guideline Machines.

Use for any other purpose is considered inappropriate. These are for example:

- The operation of other motor types and motors to those stated for the respective axis regulation controller
- Operation of the DARC system under other operating conditions than those stated in the operating instructions
- Operation of the DARC system outside the stated performance limits

Inappropriate use can cause

- damage to the DARC system,
- damage to equipment and installations of the company,
- personal injury or death.

DARC SYSTEM

Hardware Commissioning

This documentation is valid for the following equipment versions:

Module/Software	Serial number/Version
Supply module V05	V 05 - 20 - x0 - kh - xxxxx
Supply module V15	V 15 - 20 - x0 - kh - xxxxx
Supply module V05	V 05 - 30 - x0 - kh - xxxxx
Supply module V15	V 15 - 30 - x0 - kh - xxxxx
Axis regulation controller S02	S 02 - xx - xx - xxxxx
Axis regulation controller S04	S 04 - xx - xx - xxxxx
Axis regulation controller S06	S 06 - xx - xx - xxxxx
Axis regulation controller S09	S 09 - xx - xx - xxxxx
Axis regulation controller S12	S 12 - xx - xx - xxxxx
Axis regulation controller S18	S 18 - xx - xx - xxxxx
Axis regulation controller S25	S 25 - xx - xx - xxxxx
Axis regulation controller S35	S 35 - xx - xx - xxxxx

x: any entry

k: production identifier (intra-company)

h: hardware identifier (intra-company)

Date of issue:	Version 1.00	issued since:	30.07.98
	Version 1.01		20.07.99

This page remains blank for technical reasons

Contents

1 Introduction to the system	1.1
1.1 Representation of notices in the text.....	1.2
1.2 Definition of terms used	1.3
1.3 The DARC system.....	1.4
1.3.1 System components and accessories.....	1.4
1.3.1.1 Supply module.....	1.4
1.3.1.2 Axis regulation controller	1.6
1.3.2 Performance range of the DARC system	1.7
2 Safety instructions	2.1
2.1 General safety instructions.....	2.1
2.1.1 Customer's obligations	2.1
2.1.2 Working on the machine	2.2
2.1.3 Operating instructions	2.2
3 Technical data.....	3.1
3.1 Type code.....	3.1
3.2 DARC system dimensions	3.4
3.3 Supply module	3.5
3.3.1 General data / operating conditions	3.5
3.3.2 Electrical Data.....	3.6
3.3.3 Dimensions	3.7
3.4 Axis regulation controller.....	3.8
3.4.1 General data / operating conditions	3.8
3.4.2 Electrical data.....	3.9
3.4.3 Dimensions	3.10
3.5 Motors.....	3.11
3.6 Additional accessories for the DARC system.....	3.16
3.6.1 Cables.....	3.16
3.6.1.1 Motor cables.....	3.17
3.6.1.2 Network supply cable.....	3.20
3.6.1.3 Resolver cables.....	3.21
3.6.1.4 Absolute value encoder cables	3.22
3.6.1.5 Incremental position encoder cables	3.23
3.6.1.6 INC-distributor cable.....	3.24
3.6.1.7 Braking resistance and d.c. link choke cable.....	3.25
3.6.1.8 D.c. link bridge circuits	3.25
3.6.1.9 Override potentiometer cables	3.25
3.6.1.10 RS-232 Service interface cables.....	3.26
3.6.1.11 Parallel bus cable.....	3.26
3.6.1.12 Fieldbus cable Profibus-DP.....	3.27
3.6.1.13 Fieldbus plug Profibus-DP	3.27

3.6.1.14	Fieldbus cable CAN bus	3.27
3.6.1.15	Fieldbus plugs CAN bus	3.28
3.6.1.16	Module bus cable (MOBus).....	3.28
3.6.1.17	Module bus interface (MOBus)	3.29
3.6.2	Encoder systems	3.29
3.6.2.1	Incremental position encoder	3.29
3.6.2.2	Absolute value encoder.....	3.29
3.6.2.3	INC-distributor.....	3.30
3.6.3	Override potentiometer.....	3.31
3.6.4	Braking resistors	3.32
3.6.5	D.c. link filter choke	3.32
3.6.6	Mains filter for 24 V power supply	3.33
3.6.7	EMC screw connection for the motor.....	3.33
3.6.8	Screen connection terminals	3.34
4	Installation	4.1
4.1	Mechanical installation.....	4.1
4.2	Electrical installation.....	4.3
4.3	EMC measures in the DARC system	4.4
4.3.1	Equipment fastening	4.5
4.3.2	Motor leads	4.6
4.3.3	Power terminals	4.7
4.3.4	Motor connection.....	4.8
4.3.5	Fieldbus connection and other control leads	4.9
4.3.6	Filter measures.....	4.10
4.3.7	Encoder connection	4.10
4.3.8	Screening	4.10
4.3.9	Earthing.....	4.11
4.4	Connections	4.12
4.4.1	Supply module	4.15
4.4.1.1	Power terminal (terminal X11)	4.17
4.4.1.2	D.c. link circuit (Bridge L+, L-, PE)	4.18
4.4.1.3	24 V power supply (Terminal X20).....	4.19
4.4.1.4	Parallelbus (Terminal X30).....	4.19
4.4.1.5	Control in- and outputs (Terminal X6)	4.20
4.4.1.6	Absolute value and incremental position encoder interface (Terminal X8)	4.21
4.4.1.7	Measuring points (Terminal X9)	4.24
4.4.1.8	Service interface RS-232 / Override potentiometer connection (Terminal X7)	4.25
4.4.1.9	Profibus-DP-Bus connection (terminal X10).....	4.26
4.4.1.10	Profibus-DP interface baud rate	4.28
4.4.1.11	Profibus-DP wiring	4.29
4.4.1.12	CAN-Bus connection (terminal X10)	4.32
4.4.1.13	Baud rate of the CAN bus interface	4.33
4.4.1.14	CAN bus wiring	4.34

DARC SYSTEM

Hardware Commissioning

4.4.1.15 Prog/User interface (only with CAN bus interface, Terminal X12)	4.37
4.4.1.16 Module bus connection (only for CAN bus interface, Terminal X13)	4.37
4.4.2 Axis regulation controller	4.38
4.4.2.1 Motor cable connection (Terminal X5).....	4.39
4.4.2.2 D.c. link (terminal L+, L-, PE).....	4.39
4.4.2.3 24 V power supply (Terminal X20)	4.39
4.4.2.4 Parallelbus (Terminal X30).....	4.40
4.4.2.5 Peripheral equipment and holding brake (Terminal X1).....	4.40
4.4.2.6 Resolver interface (Terminal X2)	4.42
4.4.2.7 Absolute value and incremental position encoder interface (Terminal X3).....	4.43
4.4.2.8 Measuring points (Terminal X4).....	4.43
4.5 Suppressor circuits.....	4.44
4.5.1 Emergency-OFF suppressor circuits	4.44
4.5.1.1 Switching suggestions for stopping the drives using hardware	4.52
4.5.1.2 Switching suggestions for stopping the drives using hardware for gantry axis operation	4.53
4.5.2 Holding brake.....	4.57
4.6 Displays on the equipment faceplates.....	4.59
4.6.1 Supply module	4.59
4.6.1.1 Supply module with Profibus-DP interface	4.59
4.6.1.2 Supply module with CAN bus interface (SeleCAN).....	4.61
4.6.1.3 Supply module with CAN bus interface (CANOpen).....	4.62
4.6.1.4 Supply module with CAN bus interface (DeviceNet).....	4.62
4.6.2 Axis regulation controller	4.62
5 Commissioning the hardware.....	5.1
5.1 Commissioning.....	5.1
5.1.1 Personal safety measures.....	5.1
5.1.1.1 Protection against contact with live parts.....	5.2
5.1.1.2 Protection against dangerous movements	5.3
5.1.1.3 Safety measures during operation of the drives	5.3
5.1.1.4 Safety measures for servicing, maintenance and cleaning work.....	5.3
5.1.1.5 Protection against unintentional start-up for AC drives in the DARC system.....	5.4
5.1.2 Switching on for the first time	5.6
6 Operation with the service interface.....	6.1
6.1 General information.....	6.1
6.2 Programming the firmware using a terminal program.....	6.3
6.3 Programming the firmware with the program "DARC_DLD"	6.4
7 Manufacturer's declaration.....	7.1
8 Appendix	8.1
8.1 Further documentation.....	8.1
8.1.1 Norm survey.....	8.1

8.1.2 Documentation register ferrocontrol.....	8.3
8.2 List of abbreviations	8.5
8.3 Tables and parameter lists	8.6
8.3.1 D.c. link voltage.....	8.6
8.3.2 LED messages on the supply module faceplate with Profibus-DP interface.....	8.6
8.3.3 LED messages on the axis regulation controller faceplate with CAN bus interface (SeleCan)	8.7
8.3.4 LED messages on the supply module faceplate with CAN bus interface (CANOpen).....	8.8
8.3.5 LED messages on the supply module frontplate with CAN bus interface (DeviceNet).....	8.8
8.3.6 LED messages on the axis controller front plate	8.8
8.3.7 Available motor-axis regulation controller combinations	8.9
8.3.8 Dimensions of the motors.....	8.10
8.4 Dimensions of the braking resistors	8.13
8.5 Dimensions of the d.c. link filter choke	8.14
8.6 Dimensions and connections of the mains filter.....	8.16
8.7 Schemes of the DARC system	8.17
9 List of figures	9.1
10 List of tables.....	10.1
11 Index.....	11.1

1 Introduction to the system

The ferrocontrol DARC system is a modular regulating unit for control and drive systems with comprehensive performance qualities.

Based on the concept of decentral intelligence, the components of axis regulation unity (servo-amplifiers), power supply and co-ordinating intelligence as an interface to the user are combined to form a complete system.

Thus positioning, regulating and controlling tasks for brushless three-phase a.c. motors are realised by means of modular digital electronics.

A DARC system is made up of a supply module and a minimum of one or a maximum of eight axis regulation controllers, whereby each respective component is available for different performance classes.

A wide range of highly efficient interfaces are available for operating and incorporating a DARC system into a plant control system. The provision of equipment always depends on the requirements of the customer.

The following instruction manual describes the complete DARC system. Step by step and in a clear fashion, the use of all qualities and equipment characteristics which a DARC system offers in the respective configurations are represented and illustrated to the user.

All important points of installation, commissioning and parameterizing are dealt with comprehensively.

On the one hand, this operating manual is a helpful and necessary tool when first installing the DARC system; on the other hand, it serves as a reference work for the service technician working on the machine on location.

This is not a programming handbook for the DARC system. The relevant literature is referred to below (see Chapter 8.1).

1.1 Representation of notices in the text

At relevant places in the following text safety notices have been included which draw the user's attention in a clear way to possible dangers, warnings and further information.

They are distinguished by the following standardized layout:

- a pictogram which identifies the type of notice
- a notice word which specifies the type of notice
- a notice text which draws the reader's attention reader in a brief but detailed way to a danger or extra information.



Danger

This notice is a warning of an **immediate general danger or danger caused by electrical voltage.**

Disregarding this notice could lead to death or serious injury.



Warning

This notice is a warning of a **possible very dangerous situation.**

Disregarding this notice could lead to death or serious injury.



Stop

This notice is a warning of **possible damage to machinery.**

Disregarding this notice could lead to damage to the DARC system or to the surroundings

Notice

Text of notice

This notice shows a **general useful tip**.

If you follow it you can make the operation of the DARC system easier.

1.2 Definition of terms used

In this operating manual certain terms, in part special terms, are used repeatedly. In order to avoid misinterpretation and mix-ups, so the user can make a clear classification, a list of all the important terms used follows.

The abbreviations used are described in Chapter 8.2

Supply module

Describes the main component of the DARC system which is responsible for the power supply and the co-ordination of the data transfer to the digital regulators and to the overriding control centre (fieldbus connection, service interface).

Axis regulation controller

Describes one of the maximum of 8 digital regulators for motor activation. They are supplied with the necessary power and data via the supply module.

The DARC system

Describes the supply module including a maximum of 8 digital axis regulation controllers independent of the internal provision of components.

1.3 The DARC system

The DARC system is fitted ex works according to the customer's specifications. The different possibilities of hard- and firmware versions for the supply module and the axis regulation controller as well as the interfaces and their possible combinations are described. This is followed by a survey of the performance range of the system, which depends on the equipment provided.

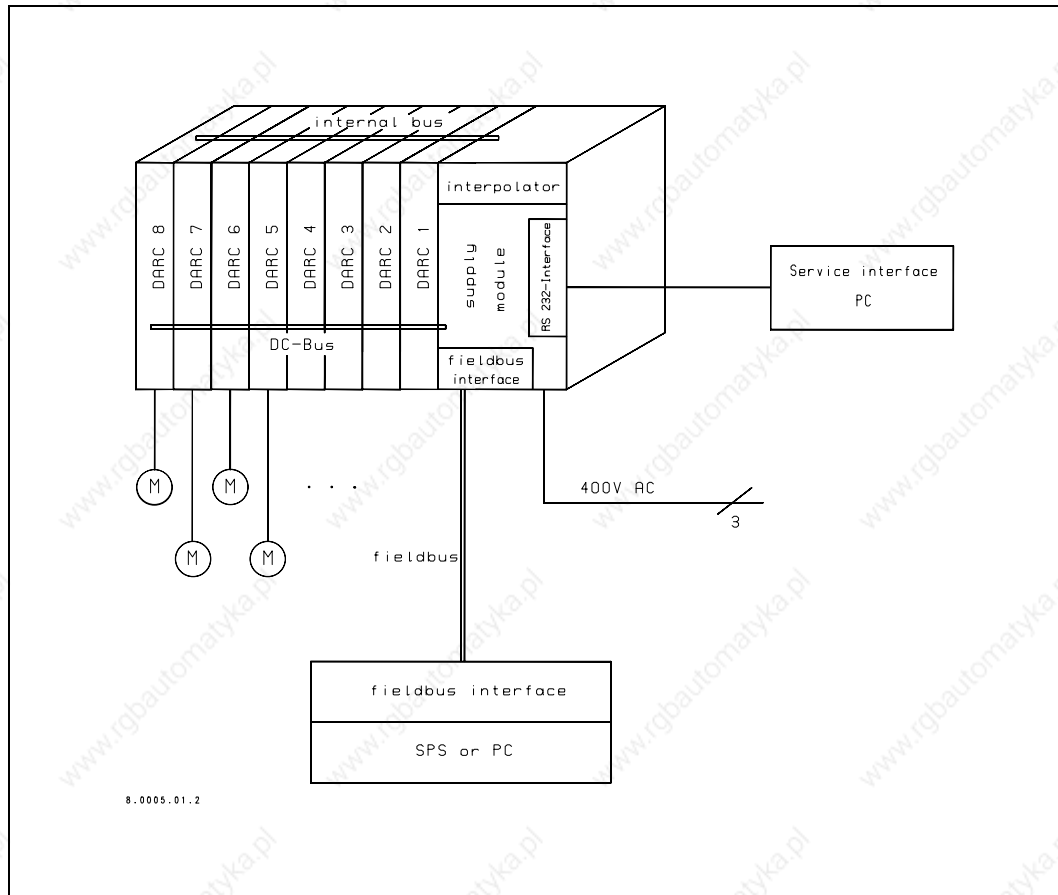

Fig. 1: The DARC system

1.3.1 System components and accessories

1.3.1.1 Supply module

The supply module is responsible for the provision of the d.c. link voltage of 600V via a direct power supply without a transformer; it coordinates the overriding tasks for managing the axis regulation controller data and the data communication of the DARC system to the fieldbus interface and to the service interface RS-232.

The supply module is available in two performance classes with 5 kW and 15 kW in the following versions (see also the type key in Chapter 3.1):

Fieldbus connection (alternative plug-in printed circuit boards in the supply module):

- Profibus-DP fieldbus interface, with all the functionalities of the DARC system, the service interface RS-232 is available, service is carried out via the fieldbus. Further information is available from the technical documentation manual "DARC System, Software Profibus-DP" (Doc. no. 97-052100) and "DARC System, Programming" (Doc. no. 97-052600).
- CAN bus fieldbus interface with SeleCan-, CanOpen-or DeviceNet interface protocol, the service interface RS-232 is available. Further information is available from the technical documentation manuals "DARC System, Software Profibus-DP" (Doc. no. 97-052100) and "DARC System, Programming" (Doc. no. 97-052600).

Notice

If no explicit reference is made at the corresponding place in this documentation, the information given about the DARC system with CAN-bus interface is valid for the SeleCan, CANopen and DeviceNet interface protocol.

Devices with CANOpen and DeviceNet protocols are not available at present!

As the processing of the process data traffic of the DARC system does not make any real-time demands on the fieldbus system, the open interface in the supply module (plug-in board solution) enables the adaptation to other fieldbus systems not stated above.

Service interface RS-232 combines with one of the above-listed fieldbus connections:

- for parameterization, commissioning and simple axis positioning on the PC. If it is implemented as standard in CAN and the profibus, the user-interface software (DARCTOOL) must be ordered specially from ferrocontrol.

Override potentiometer connection:

- to limit the offset speed of the axes

Interpolator (optional plug-in board in the supply module):

- provides the computing capacity for the coordinated movement of several axes.

- Is necessary for the function "electronic gearing" (deriving an axis movement from another measured movement) and for 1-D to 3.5-D interpolation (generation of defined 3-d curves with a multi-axis kinematic chain). The interpolation module is not necessary for the pure positioning of individual axes.
- A precondition is when the additional encoder on the supply module is to be used.

Additional encoder interface (plug-on board within the supply module):

- optionally for an incremental encoder or an SSI data interface for absolute value encoders with Gray code (interpolator absolutely necessary).
- can be used for measuring actual values externally or as a control value or correction encoder for gearing.

Fieldbus connection	Available versions		
CAN bus interface	a	a,c	a,b,c
Profibus DP interface	a		

Table 1: Survey of available supply module versions

Equipment	Abbreviation	Recognition after reset
Basic version inc. service interface RS-232 and override potentiometer connection	a	yes
Master encoder interface (choice of SSI or INC)	b	yes
Interpolator	c	yes

Table 2: Possible versions of the supply module

1.3.1.2 Axis regulation controller

The axis regulation controllers are always fitted for a resolver feedback in the motor. This allows the electronic commutation of the brushless polyphase machines. The resolver feedback is also used in the basic version for speed and positioning detection.

In some technologically determined cases an additional encoder interface is used as a version variant:

- If the position detection cannot or should not be carried out directly at the motor shaft, an axis controller with an incremental encoder interface and an additional incremental encoder on the machine are to be provided.
- If a reference trip is not possible, an axis controller with SSI standard interface and an absolute value encoder at the machine should be chosen.

- For particularly exact and direct distance measurement with additional encoders at the machine, you can choose between an axis controller with SSI or an incremental interface (compare with the type key), depending on the encoder used.

Version	Recognition after reset	Available with
additional encoder interface (choice between SSI or INC)	yes	S2, S4, S6, S9, S12, S18, S25, S35

Table 3: Possible versions of the axis regulation controller

1.3.2 Performance range of the DARC system

In the following the qualities and functionalities that the DARC system offers are described in keywords.

Basic characteristics of the drive system:

- Servo-amplifier made up of speed regulation, current regulation and motor control. These functions are carried out digitally. For DARC this also includes current regulation as a field-orientated regulation in stator co-ordinates
- The complete range of functions of the classic servo-amplifier is taken over by just one chip, i.e. the high-powered motor controller 87C196MC from Intel
- The drive regulation controllers of the DARC system are designed for motors with pole numbers 2, 4, 6 and 8
- Very smooth running is ensured by sine-shaped pulse-width modulation, also at low speeds
- Low-loss compact axis regulation controllers with a voltage d.c. link inverter based on a compact IGBT module. This results in low on-state power losses and a low control/ drive performance
- Low-noise motion by means of clock frequency outside of audibility range
- Rotor position and actual speed value assignable by means of robust resolver feedback up to 16 bits resolution
- Connection of an absolute shaft-angle encoder with an SSI interface or of an incremental encoder is possible in order to be able to perform direct distance measurement at machines, in the case of the absolute shaft-angle encoder without a reference trip
- If the supply module is fitted with an additional master encoder interface it is possible to measure speeds and distances on externally driven shafts
- Correction of regulator settings due to temperature and voltage drift is no longer necessary

- Service exchange of motor regulators is possible without readjustment. Specialists are not necessary as the supply module transfers all settings and parameters automatically and correctly to the new apparatus
- Commissioning becomes much simpler as the motor parameters can be taken automatically tables on file when the motor type is entered.
- Storage of up to four parameter records per axis in the Flash-EPROM of the supply module, i.e. the complete parameter records need only be transferred and stored when the system is set up for the first time. After that they can be loaded as required from the supply module and transferred to the controllers.
- 600 V d.c. link voltage by means of direct supply at the supply module for 8 drives renders power transformers redundant
- Wide operational voltage range from 3 x 380 V - 10% to 415 V + 10%, at 50/60 Hz
- Axis regulation modules with nominal current from 2 A to 35 A (peak currents twice as large respectively)
- Phase monitoring in the power circuit
- Measurement of the d.c. link voltage and provision of the value in the supply module
- Wiring requirements are considerably reduced because of a fieldbus connection between the user terminal and the local supply module
- If the customer desires, additional fieldbus connections which enable connection to the control world can be integrated into the supply module.
- Thanks to local intelligence and interpolation in the supply module, a real-time capable fieldbus is no longer necessary
- The Profibus or CAN fieldbus interface makes a modern operating interface available for an industrial PC with a serial interface (RS-232) which offers a large number of dialogue-guided operating and observation elements for situations that arise in installations such as malfunctions, commissioning, parameter setting, oscilloscope functions
- Rapid, differentiated diagnosis is possible if a malfunction occurs
- Parameterization is purely digital. This means that the regulating parameters and modes of operation can be changed quickly and safely
- Oscilloscope functions offer the graphic display of e.g. acceleration and braking curves, torque etc. and make the optimization of the settings easier.
- The drive profile generator allows different common positioning profiles to be input. Linear ramps such as the jolt-free sine² function can be selected
- Independently adjustable acceleration and deceleration ramps
- Linear ramps or sine²(t) ramps can be parameterized.

- Motion without following error is possible
- Positioning via resolver or
- Positioning via an external (2nd) incremental or absolute value encoder in the axis regulation controller (version-dependent)
- Adjustable torque limiting
- Input of an override potentiometer to limit the traversing speed

Single axis operation:

- Independent positioning of up to 8 position-controlled axes per supply module. With a word width of 32 bits in the position controller, a position resolution of 16 bits per revolution and 32768 clockwise and anti-clockwise revolutions are possible.
- Torque regulation (motion with a precisely defined torque in a preset direction)
- Speed-regulated operation is possible without position control
- Operation of endlessly running rotary axes (display range from 0° to 360°)
- Synchronously started positioning from axes bundled in groups for different set positions. Here it doesn't matter on which of the supply modules of an installation these axes are.

Gantry axis operation:

- The functionality "Gantry axes" of the DARC system makes it possible to bundle axes together in groups on one supply module and to move them angle-synchronously (including speed- and acceleration-synchronously). Thus, behaviour which corresponds to a great extent to a rigid mechanical coupling (without following error to the master axis) can be simulated on the control side using software.
- In contrast to "gearing" (electronic gears) synchronization (for example, the acceleration of a stationary axis to the speed of a moving axis) is not possible; instead greater importance is attached to safety by the implementation of synchronous operation monitoring

Electronic gearing only when an interpolator module is used

- The activation of an axis (slave) is derived from the position values of a source provided in the system clock, taking into consideration a transformation factor

- The following sources (so-called masters) are available: the (resolver) actual values of an axis; the second encoder of an axis (if connected); the additional encoder on the supply module; the set value settings of an axis if it is activated by the interpolator module; the set values of a virtual axis; or a specifiable fixed speed which can be altered during runtime.
- 2 variants can be selected:
For position-synchronous gearing one synchronous range of motion each is allocated to the master and slave in its axis coordinate system. This operating mode is suitable, among others, for realising a "flying saw" (tracking saw).
For synchronous-speed gearing, synchronous motion of the slave is produced regardless of the current movement status of the master. If necessary, a second source can be stated here, in order to allow for a correction value (e.g. of a position offset).
- Various synchronous motion monitoring mechanisms and adjustable reaction patterns have been implemented.
- A flexible application is possible:
Any axes can be dynamically included in the gearing under the control of the sequence controller, and can be removed again.
Several axes can refer to one master at the same time; one master can, for its part, be the slave of another master or can be part of an interpolation group; the gearing factor can be altered during runtime and a gearing function overriding the supply modules can be realized by means of an incremental encoder whose actual values are fed into different supply modules via INC-distributor (extra module from ferrocontrol).

Contouring control (multi-axial interpolating positioning of the axes of a supply module):

- The axes of a supply module can be joined together freely into interpolation groups; the configuration can be altered dynamically by reparameterization. The DARC system is capable of managing several interpolation groups simultaneously.
- Various features of single axis positioning can also be transferred to interpolation: stating the ramp form and the dynamic values (acceleration, speed) with reference to the contour movement, override etc. are to be assigned to an interpolation group as a parameter record.
- 1-D*, 2-D and 3-D interpolation (for Cartesian axis kinematics) can be used as well as (if necessary) a tangentially tracking or separately addressed C-axis. (*1-D-IPO also makes available all special features of interpolation for single axis movements; 1-D + C makes defined thread cutting possible)

- Contour definitions consist of a series of geometric elements, one after another, of the type straight line, circle (for 2-D) or helix (for 3-D; orientated in the direction of the main axis)
- The absolute position of the contours in the working area (shifting, rotating on a main level) can be varied by means of various available possibilities of intervention.
- The contour definitions must be transferred via the fieldbus in a format following the DIN-NC code and can be filed locally (storage-resistently) in the Flash-EPROM of the interpolator.
- Complete contour definitions undergo an initialization calculation as a whole (of the geometric curve and the contour speed profile) and can then be driven as often as required.
Giving priority in this way to the record initialization allows the arithmetic capacity available to concentrate on the generation of the cyclical auxiliary values and thereby to improve precision.
- The results of the initialization calculation can be accessed by upload. An appropriate interface software can visualize the expected motion performance or calculate processing times.
- If contour precision is maintained, the originally programmed contour speed can be reduced at will by the sequence controller before or during motion, beyond the standstill up to the direction reversal. (+100%...0%...-100%)
- Halting interpolation at any point on the contour is possible as well as subsequent further motion from this position. In the meantime, individual axes can be removed and be repositioned back again.
- Alongside the complete processing of contours, it is also possible to lower and to start forwards or backwards from there. This means that unexpected asynchronous abnormal terminations such as emergency off can be dealt with appropriately.
- Contours can be directly linked, one after another, where communication with the sequence controller is not necessary (confirmation of reaching the endpoint, subsequently a new motion order with acknowledgement etc.). This is advantageous for time-critical applications.
- Every endpoint of an NC record can be defined as a "waiting point", which forces the interpolation to be halted in this position until the sequence controller transmits an explicit enabling command to continue (to be used for synchronizing partial movements or as a safety interlock).
- "Distance markers" can be set along the contour; when they are passed, switching signals are transmitted to the sequence controller (electronic cam function).

- Online feedback of comprehensive information about the present state of motion from the interpolator to the sequence control.

This page remains blank for technical reasons

2 Safety instructions

2.1 General safety instructions

The DARC system corresponds to the most up-to-date state of technology and is fundamentally safe to operate.

Failing to observe the following safety instructions can lead to serious injury or to damage to equipment or machines.

2.1.1 Customer's obligations

- The DARC system may only be used for specified purposes.
- The DARC system may only be commissioned after the operating instructions have been carefully studied and only by qualified electricians or by persons under their instruction.
- These operating instructions must be kept ready to hand near the installation in a complete and perfectly readable condition.
- As well as the operating instructions and the valid binding regulations for the prevention of accidents in the country of use and the operation location, the recognized specific technical rules for safe and proper operation must be observed.
- In order to carry out installation and commissioning of the products described and to guarantee safety during operation and maintenance, the knowledge and the correct execution of the safety information and warnings contained in these operating instructions are a necessary precondition.
- When one or several drive axes are being commissioned technical errors must be taken into account such as, for example, NC program errors, wiring errors or monitoring devices that are not in operation. Therefore you must proceed with commissioning in a careful and co-ordinated manner in order to avoid accidents (see also Chapter 5).
- Precautions must be taken that program and parameter changes are only carried out by qualified and authorized personnel.

2.1.2 Working on the machine

- The general maintenance work may only be carried out by instructed persons in accordance with the operating instructions.
- The construction of the machine must guarantee that operation, set-up and maintenance when used as specified do not result in danger to persons. The operators are to be made aware of any remaining dangers due to the protective measures executed possibly not being fully effective.
- If persons are working within range of the moving parts of a machine, for example, during commissioning or maintenance work, drives which could cause hazardous movements must be switched off and made safe against unintentional restarting. The power conductor or, preferably, the main switch should be turned off and should be prevented from being switched on unintentionally. The drive after-running must be finished (see also EN1037, "Disconnection from power supply and power decline, prevention of unexpected start-up")
- Working on live parts and equipment is not permitted. The exceptions are covered in DIN VDE 0105 or VBG 4.
- Conversions or changes to the installation may only be carried out in accordance with all safety precautions. This is also valid for work on the electrical installation. After the main switch has been turned off the discharge time of the d.c. link must be taken into account. Dangerous voltage can still occur 1 minute after line disconnection.

2.1.3 Operating instructions

In order to guarantee the clarity of the manual, all details for all design variants of the products described could not be considered for all possible applications. Should the information given prove to be insufficient or should special problems occur, for which this document does not provide sufficiently detailed information, please ask ferrocontrol for further information.

Notice

In Chapter 8.1 you can find a survey of further documentation from ferrocontrol.

3 Technical data

3.1 Type code

On the front panel of all supply modules and axis regulation controllers there is a type sticker. This shows information about the type, the equipment of the respective module and about the production series.

The type code and the serial information for the **supply module** is coded as follows:

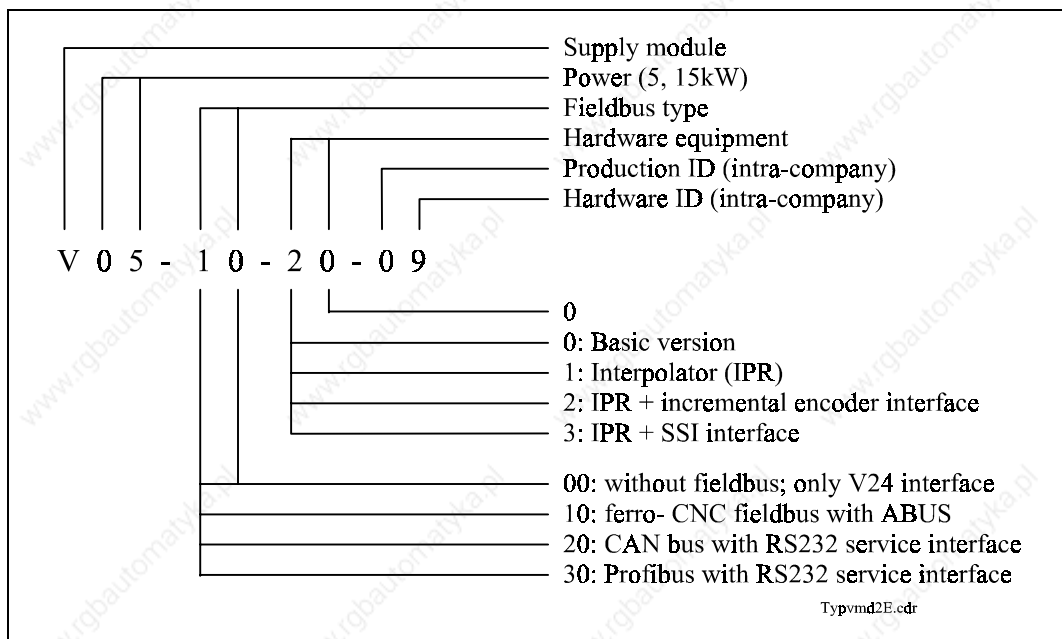

Fig. 2: Type code supply module

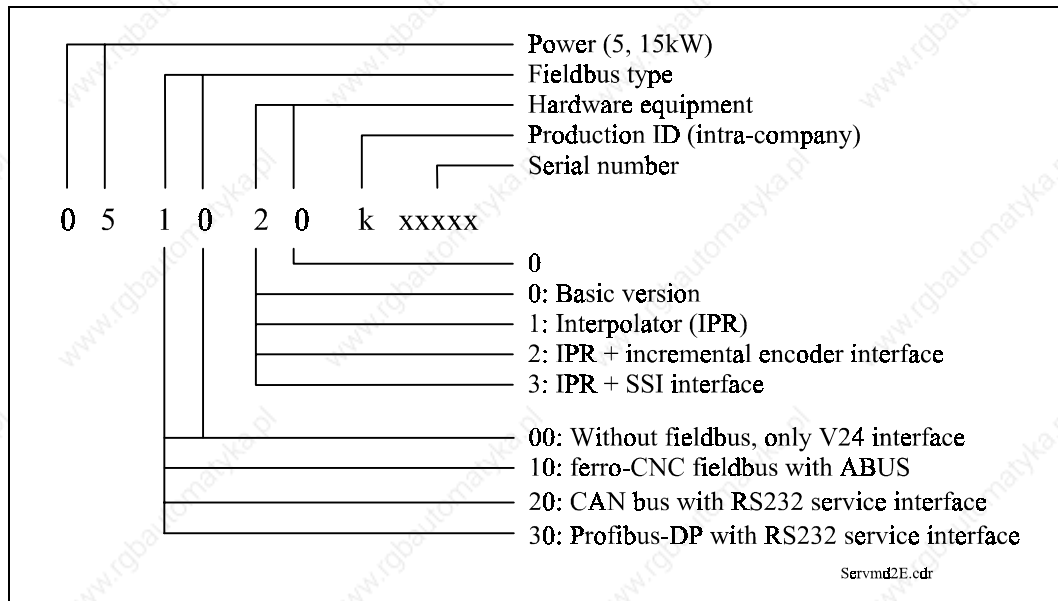

Fig. 3: Serial number supply module

The type code and the serial information for the **axis regulation controller** is coded as follows:

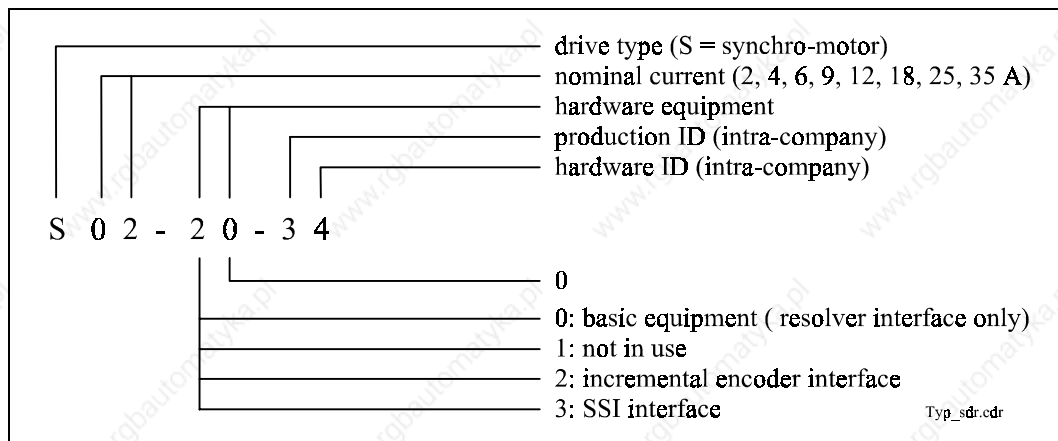

Fig. 4: Type code axis regulation controller

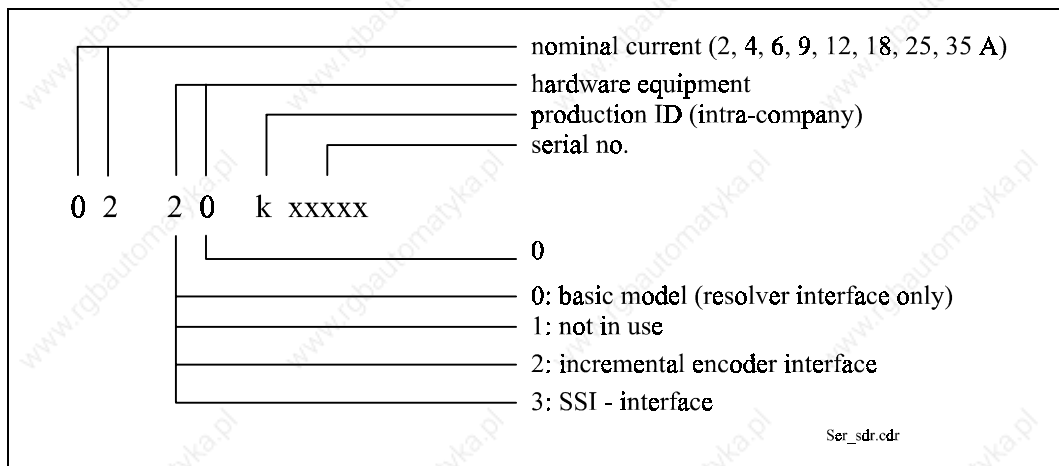

Fig. 5: Serial number axis regulation controller

3.2 DARC system dimensions

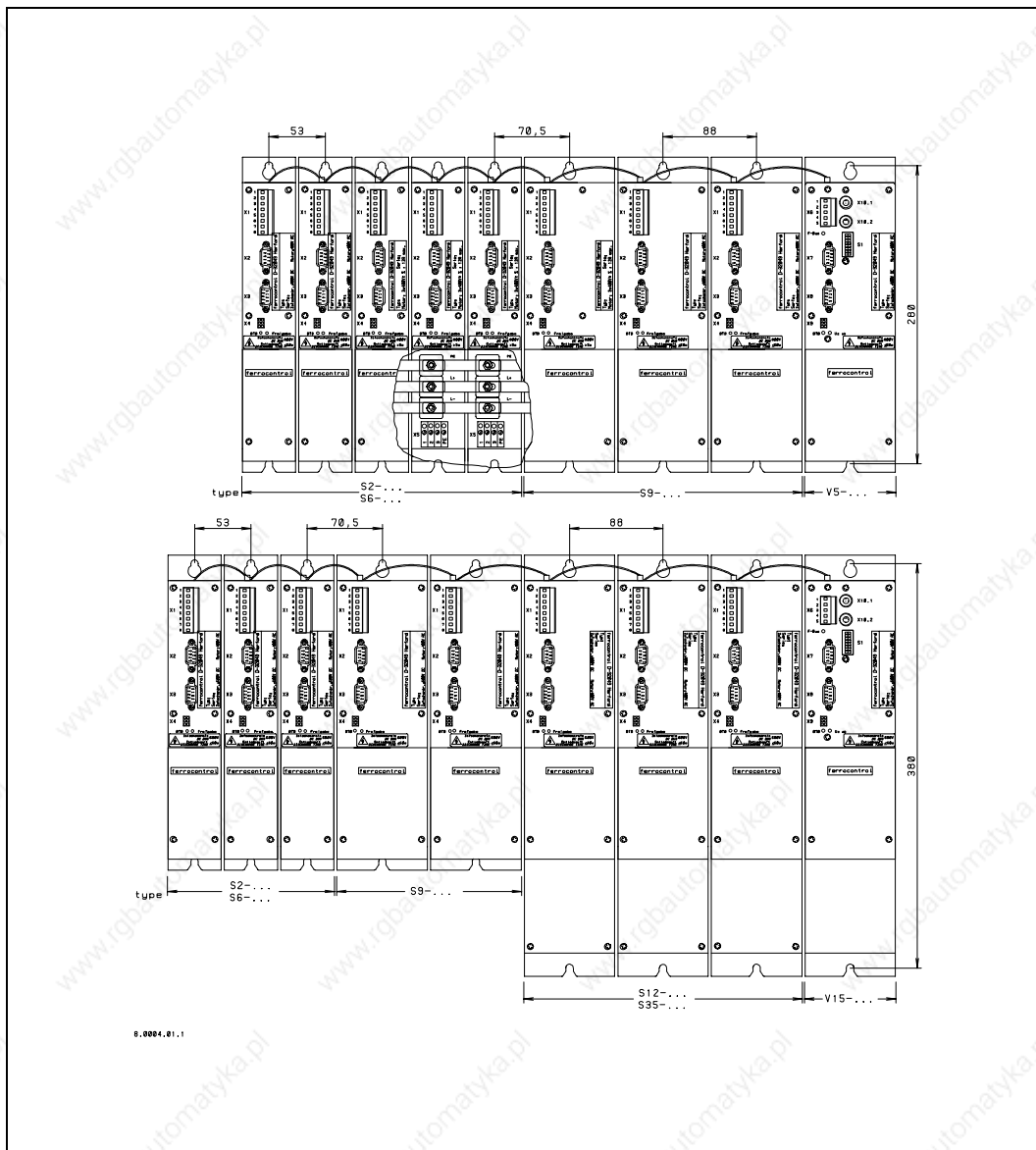

Fig. 6: Mechanical design of the DARC system

Notice

There must be a standard fitting depth provided for of 370 mm, including plugs and coverings. The fitting sequence is to be carried out in such a way that the axis regulation controller with the smallest output is the furthest distance from the supply module. Above and below the devices there must be a free space of at least 80mm, enabling the air to circulate freely through the devices. Devices emitting a lot of heat (such as braking resistors) must also have a space of 80mm at the sides.

Notice

Information about the dimensions of the individual module components can be found in Chapters 3.3.3 and 3.4.3!

3.3 Supply module

3.3.1 General data / operating conditions

TYPES	V5	V15
Protection type	IP 20 (DIN 40050)	IP 20 (DIN 40050)
Operating type	DB (DIN 57558 Part 1)	DB (DIN 57558 Part 1)
Cooling method (DIN 41 751)	Convection	Convection
Environment temperature	0°C ... 45°C	0°C ... 45°C
Installation height	Pos. above sea level < 2000 m	Pos. above sea level < 2000 m
Mass m	3.8 kg	7.0 kg
Dimensions of housing, B x H x D [mm ³]	88 x 300 x 335	88 x 400 x 335
Emitted interference	EN 55 011	EN 55 011
Interference immunity	ENV 50 140 (1995) EN 61000-4-2 ENV 50 141 IEC 801-4	ENV 50 140 (1995) EN 61000-4-2 ENV 50 141 IEC 801-4
Insulation resistance	Overvoltage category III acc. to VDE 0110	Overvoltage category III acc. to VDE 0110
Vibration resistance	IEC 68-2-6 check Fc	IEC 68-2-6 check Fc
Humidity stress	EN 60068-2-3 Ca IEC 68-2-3 / 2.1 Ca	EN 60068-2-3 Ca IEC 68-2-3 / 2.1 Ca

Table 4: General data supply module

3.3.2 Electrical Data

TYPES	V5	V15
Grid: Nominal voltage U_{grid} permitted range	3 x 400 V 380 V -10 % to 415V +10%	3 x 400 V 380 V -10 % to 415V +10%
Current I_{grid}	10 A	32 A
Frequency f_{grid}	50 Hz to 60 Hz	50 Hz to 60 Hz
D.c link circuit Voltage U_Z Nominal current I_Z Nominal power P_Z Peak power P_{Zmax} (max. 7s)	560 V 9 A 5 kW 10 kW	560 V 27 A 15 kW 30 kW
Braking resistance external, R (+/- 10 %)	≥ 33 Ohm	≥ 16 Ohm
Peak braking power P_{BRC} electric	14 kW at 33 Ohm	28 kW at 16 Ohm
Electronics supply (must have external slow fuse)	24 V / 0,4 A (18 V ... 30 V)	24 V / 0,6 A (18 V ... 30 V)
D.c. filter link choke (to be switched externally)	1,1 mH; 10 A	0,4 mH; 30 A
Mains filter (3-phase)	integrated for EN 55011/3.91 Group 1, Class A	integrated for EN 55011/3.91 Group 1, Class A
Power loss at $P_Z = 0$	10 W	15 W
Power loss at P_Z nom (without braking resistance)	33 W	77 W
Relay contact for operation readiness	30 V / 1A	30 V / 1A
Control inputs (all opto-isolated): max. input voltage max. input current Logic high Logic low	30 V 18 mA $U > 18$ V $U < 3$ V	30 V 18 mA $U > 18$ V $U < 3$ V
For types with incremental encoder interface	Input frequency ≤ 160 kHz	

Table 5: Electrical data supply module

When using the supply module V15 the available power in the d.c. link circuit can be doubled by a second V 15 module in the DARC system. The switching variant is available from ferrocontrol on request.

3.3.3 Dimensions

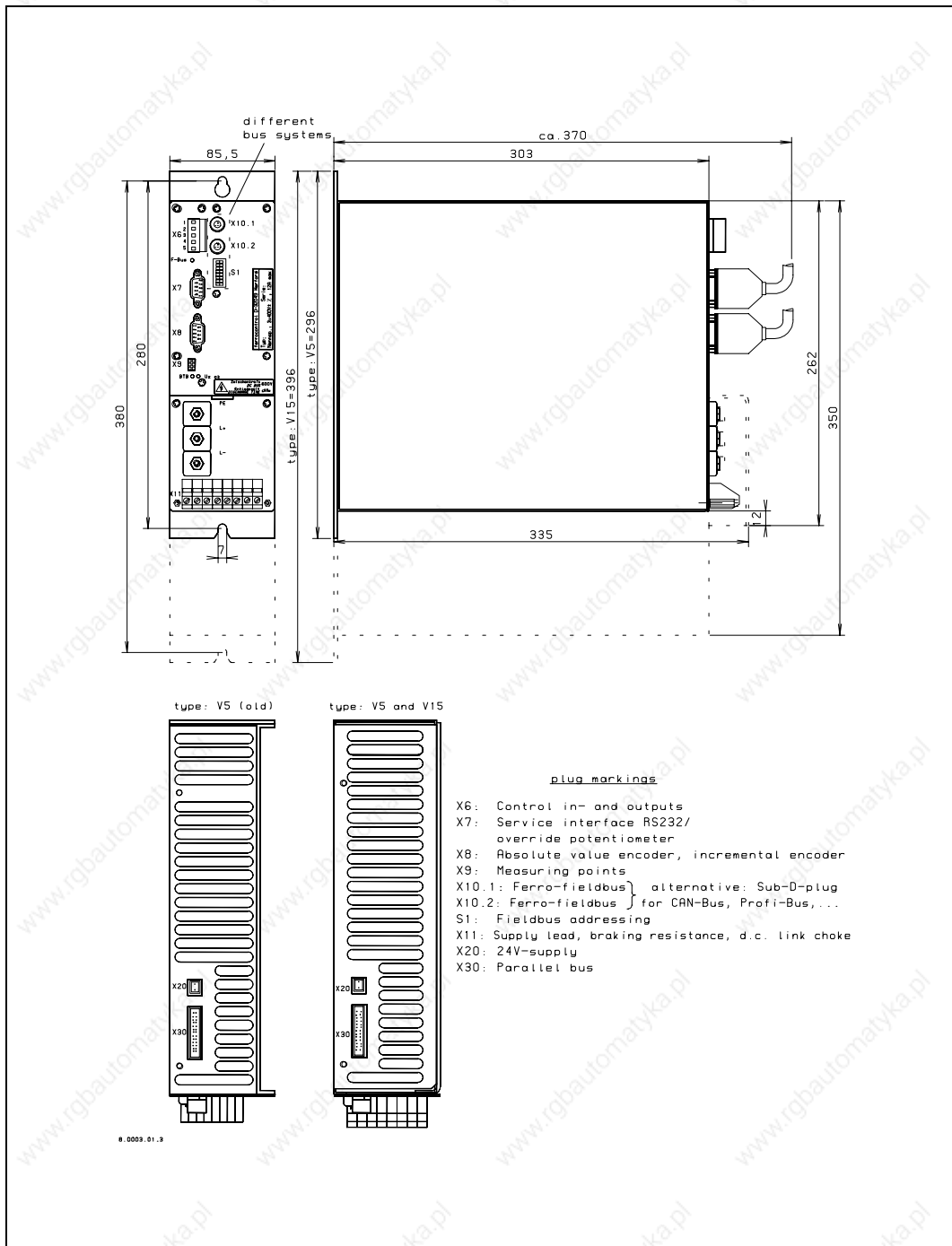

Fig. 7: Dimensions of the supply modules

The information on the plug connections in the above illustration refers to the use of the ferrocontrol CNC fieldbus. The dimensions of the installations are identical when other fieldbus connections are used, however the design of connection X10 has been

changed and additional connections, DIP switches or LEDs can be provided on the front panel.

Notice

Information about the supply module connections can be found in Chapter 4.4.1!

3.4 Axis regulation controller

3.4.1 General data / operating conditions

TYPES	S2	S4	S6	S9	S12	S18	S25	S35
Protection type	IP20 (DIN 40050)							
Operating type	DB (DIN 57558 Part 1)							
Cooling type (DIN 41751)	Convection					Fan		
Ambient temperature	0°C ... 45°C						0°C ... 40°C	
Mass M _{MP}	3.1 kg			7.0 kg	10 kg			
Installation height	Location above sea level ≤ 2000 m							
Housing dimensions W x H x D	53 x 300 x 335			88 x 300 x 335	88 x 400 x 335			
Emitted interference	EN 55 011							
Interference immunity	ENV 50 140 (1995) EN 61000-4-2 ENV 50 141 IEC 801-4							
Insulation resistance	Overvoltage category III acc. to VDE 0110							
Vibration resistance	IEC 68-2-6 Test F							
Humidity stress	EN 60068-2-3 Ca, IEC 68-2-3 / 2.1 Ca							

Table 6: General data axis regulation controller

3.4.2 Electrical data

TYPES	S2	S4	S6	S9	S12	S18	S25	S35
Input voltage = U_Z D.c link voltage (permitted range)	560 V = 480 V to 650 V							
Output voltage U_N	0 to U_{Netz}							
Nominal output current $I_{N(eff)}$ in A	2	4	6	9	12	18	25	35
Peak output current for max. 7s I_{max} (eff)	2 x I_N							
Electronics supply (needs external slow fuse)	24 V / 0,4 A (18 V ... 30 V)				24 V/0,6 A (18 V...28 V)			
Power loss when output is blocked	10 W				15 W			
Nominal stress power loss in watts	35	55	80	120	150	210	300	395
Output clock frequency	2 x 8 kHz							
Relay contact for the holding brake	30 V / 1 A, for motors HD 142 and BMR 190 a coupling relay is necessary							
Control inputs (all opto-isolated): Max. input voltage Max. input current Logic high Logic low	30 V 18 mA $U > 18$ V $U < 3$ V							
Motor temperature monitoring	for PTC temperature sensor operating/response resistance approx. 2.5 k Ω or temperature switch							
For types with incremental position encoder interface	Input frequency ≤ 160 kHz							

Table 7: Electric data axis regulation controller

3.4.3 Dimensions

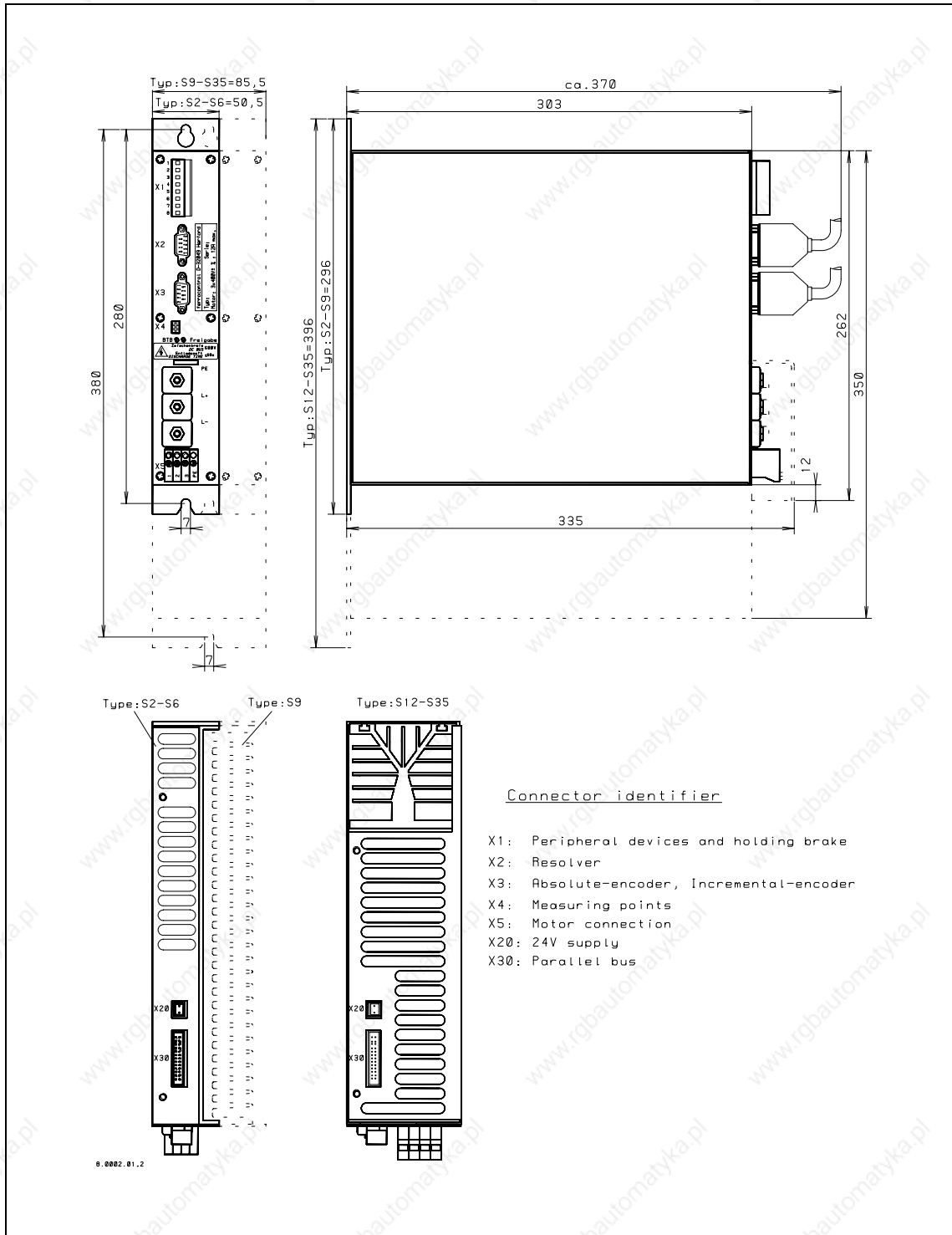

Fig. 8: Dimensions of the axis regulation controller

Notice

You will find information about the connections of the axis regulation controller in Chapter 4.4.2.

3.5 Motors

The axis regulation controllers are designed for controlling high-dynamic servo-motors, permanent-field - three-phase - synchronous motors.

As a system supplier, ferrocontrol delivers the optimally suitable motors including cable set for your drive requirements. In addition, a special, optimized parameter set will be provided for every motor-axis regulation controller combination. These parameter blocks can be managed from the user-interface of the overriding controller centre (PLC, visualization /visual display system) in a library. The respective current data of the motor parameter sets are delivered by ferrocontrol with the software of the service interface RS-232 or with the appropriate ferrocontrol CNC fieldbus.

The parameter set also contains the adaptation of the resolver adjustment. For the purpose of resolver adjustment, the service interface provides a test function with which the value for the resolver offset can be set.

Mechanical design features of the motors:

- Flange according to DIN 42677; special flange on request
- Axis height tolerance according to DIN 747
- Construction type DIN IEC 34, Section 7
- Flange precision according to DIN 42955
- External fan on request
- Bearings according to DIN 42966 with lubrication according to DIN 51825, Section 1
- Degree of protection IP65
- Motors are available with and without a brake

Electric design features of the motors:

- Insulation class F
- Motors correspond to DIN VDE 0530, EN 60034, ISO 34.1
- Motor pole number 2, 4, 6 or 8
- Motor-integrated 2-pole resolver

The information on the nameplates of the manufacturers vary greatly and contain a variety of information according to different definitions. ferrocontrol has calculated application data for a wide range of drives in connection with the appropriate DARC types and has listed them below.

The nominal data for the speed/torque diagram can be read from the table of the application data.

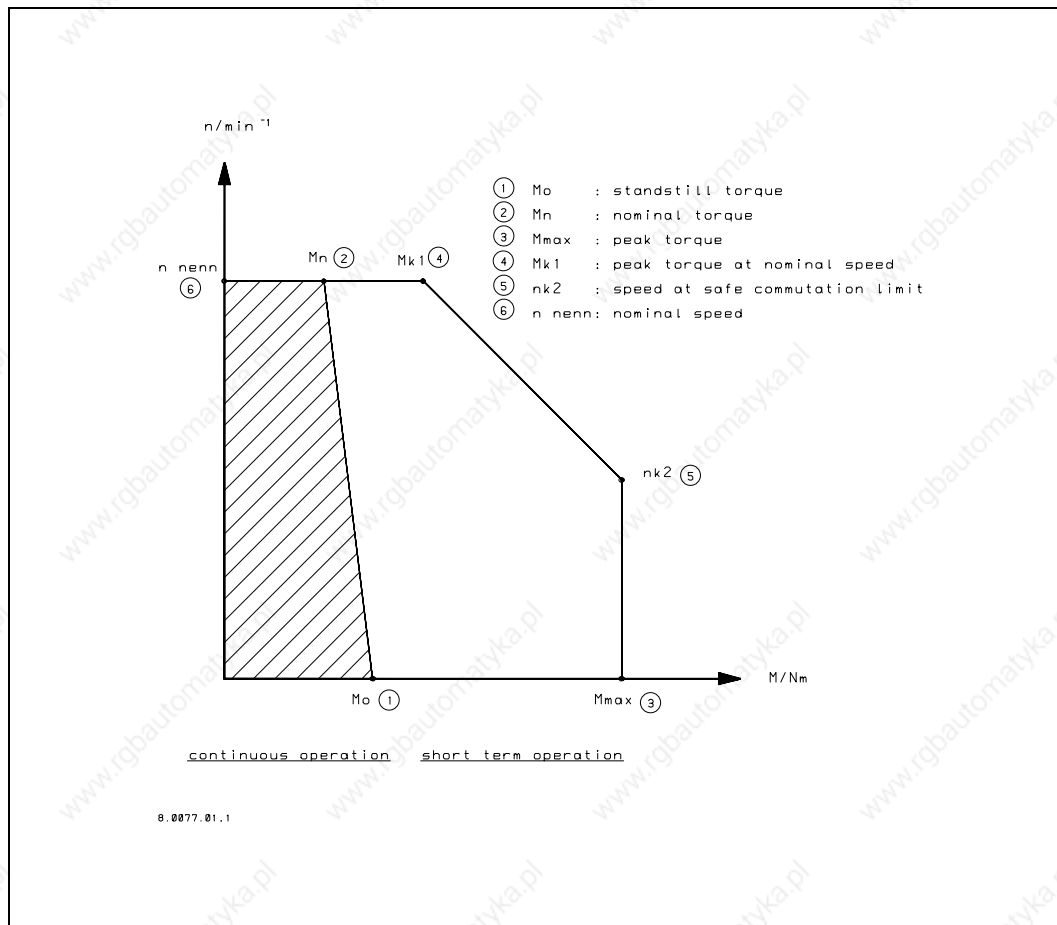

Fig. 9: Speed/torque characteristic curve

Notice

Further motor-axis regulation controller combinations are possible and can be requested from ferrocontrol.

On the basis of the motor selection data the **middle d.c. link power** P_{mz} for a motor type/ regulator can be calculated (compare Table 9), which is to be used as a standard value for designing multi-axis drive packages.

Standstill torque M_o (Nm)	Peak torque M_{max} (Nm)	Nominal speed (U/min)	Motor type/regulator	medium d.c. link power
				P_{mz} (in kW) for each motor
0.6	2.4	6.000	HD 70A4-64 / S2	0.24
0.7	2.4	6.000	HD 92A4-64 / S2	0.28
0.8	2.8	6.000	HD 55G4-64 / S2	0.32
1.2	3.0	6.000	HD 70C4-64 / S2	0.48
1.5	3.0	6.000	HD 92C4-64 / S2	0.6
1.8	4.0	4.500	HD 70E4-88 / S2	0.54
3.0	8.1	4.500	HD 92G4-88 / S4	0.9
3.0	10.1	3.000	HD 92G4-130 / S4	0.6
3.7	9.0	6.000	HD 115A6-64 / S6	1.5
3.7	8.1	4.500	HD 115A6-88 / S4	1.1
3.7	12.0	3.000	HD 115A6-130 / S4	0.75
5.2	12.2	4.500	HD 115B6-88 / S6	1.5
5.2	12.2	3.000	HD 115B6-130 / S4	1.0
6.8	18.3	4.500	HD 115C6-88 / S9	2.1
6.8	18.3	3.000	HD 115C6-130 / S6	1.35
9.8	27.0	6.000	HD 115E6-64 / S18	3.9
9.8	24.5	4.500	HD 115E6-88 / S12	3.0
9.8	27.5	3.000	HD 115E6-130 / S12	2.0
11.3	24.5	4.500	HD 142C6-88 / S12	3.4
11.3	27.5	3.000	HD 142C6-130 / S9	2.25
16.0	36.7	4.500	HD 142E6-88 / S18	4.8
16.0	36.7	3.000	HD 142E6-130 / S12	3.2
21.0	37.5	6.000	HD 142G6-64 / S35	8.4
21.0	36.7	4.500	HD 142G6-88 / S18	6.3
21.0	55.0	3.000	HD 142G6-130 / S18	4.2
24.0	51.0	4.000	BMR 190C6-88 / S25	6.4
24.0	55.0	3.000	BMR 190C6-130 / S18	4.8
36.0	76.5	3.000	BMR 190E6-130 / S25	7.2
48.0	105.0	2.000	BMR 190G6-180 / S25	6.4
48.0	107.0	3.000	BMR 190G6-130 / S35	9.6

Table 9: Medium d.c. link power P_{mz} of the motor-axis regulation controller combinations

The calculation is made with:

$$P_{mz} = M_0 [Nm] * 2 * \pi * n_{mittel} [1 / s]$$

whereby $n_{medium} = 63\% \times n_{nom}$

The dimensioning for the multi-axis drive packages is carried out on the basis of the medium d.c. link power P_{mz} for each axis.

$$P_{mz(gesamt)} = P_{mz(1)} + P_{mz(2)} + P_{mz(3)} + \dots + P_{mz(n)}$$

8-axis	Pmz (total)	CCF	Supply module
V5:	13.0 kW	2.6	V5: 5 kW
V15:	39.0 kW	2.6	V15: 15 kW
7-axis	Pmz (total)		Supply module
V5:	13.0 kW	2.45	V5: 5 kW
V15:	39.0 kW	2.45	V15: 15 kW
6-axis	Pmz (total)		Supply module
V5:	11.2 kW	2.25	V5: 5 kW
V15:	33.7 kW	2.25	V5: 15 kW
5-axis	Pmz (total)		Supply module
V5:	10.0 kW	2.00	V5: 5 kW
V15:	30.0 kW	2.00	V15: 15 kW
4-axis	Pmz (total)		Supply module
V5:	8.7 kW	1.75	V5: 5 kW
V15:	26.2 kW	1.75	V15: 15 kW
3-axis	Pmz (total)		Supply module
V5:	6.6 kW	1.32	V5: 5 kW
V15:	19.8 kW	1.32	V15: 15 kW
2-axis	Pmz (total)		Supply module
V5:	5.7 kW	1.15	V5: 5 kW
V15:	17.2 kW	1.15	V15: 15 kW

Table 10: Dimensioning of the multi-axis drive packages

CCF Concurrence factor

The selection list can serve as a guideline for typical CNC applications if exact drive information is not available. Where exact values for effective torque, medium speed and concurrence of the axes are known a computational check of the drive packages must be carried out. The performance information given in the tables **do not guarantee a function** in all applications.

Notice

The dimensions and the dimension drawings are given in the appendix in Chapter 8.3.8.

3.6 Additional accessories for the DARC system

ferrocontrol provides the necessary accessories for the required configuration for the DARC system. The most commonly available components are listed below. A description of the connection possibilities for the respective accessories to the system can be found in Chapter 4.4.

3.6.1 Cables

Notice

The observance of the EMC guidelines and safe functioning of the controller can only be guaranteed when the cable material and screening prescribed by ferrocontrol are used.

The DARC motor and resolver cables are special cables and are produced specially for the DARC drive system.

- All cables are highly flexible and are particularly suitable for application in drag chain operation and in power supply chains with extremely small bends and fast motion sequences.
- They have a high resistance to liquid coolants and lubricating oils.
- The outer sheath is orange (RAL 2003) and has ferrocontrol type printing.
- The same is true for the ferrocontrol cables for the fieldbus, incremental and absolute value encoders.

The following connection cables can be supplied preassembled by ferrocontrol.

3.6.1.1 Motor cables

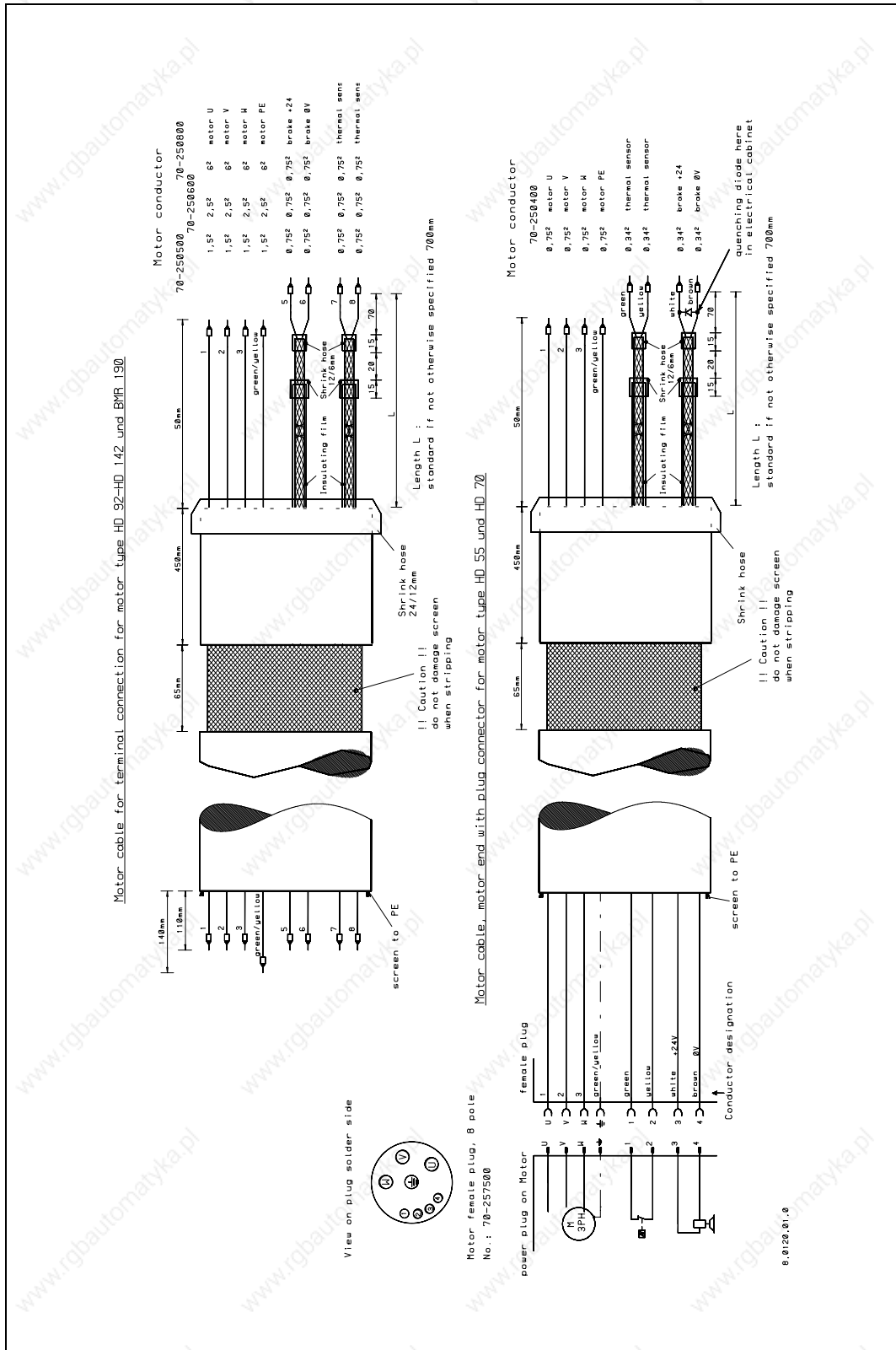

Fig. 10: Motor cables

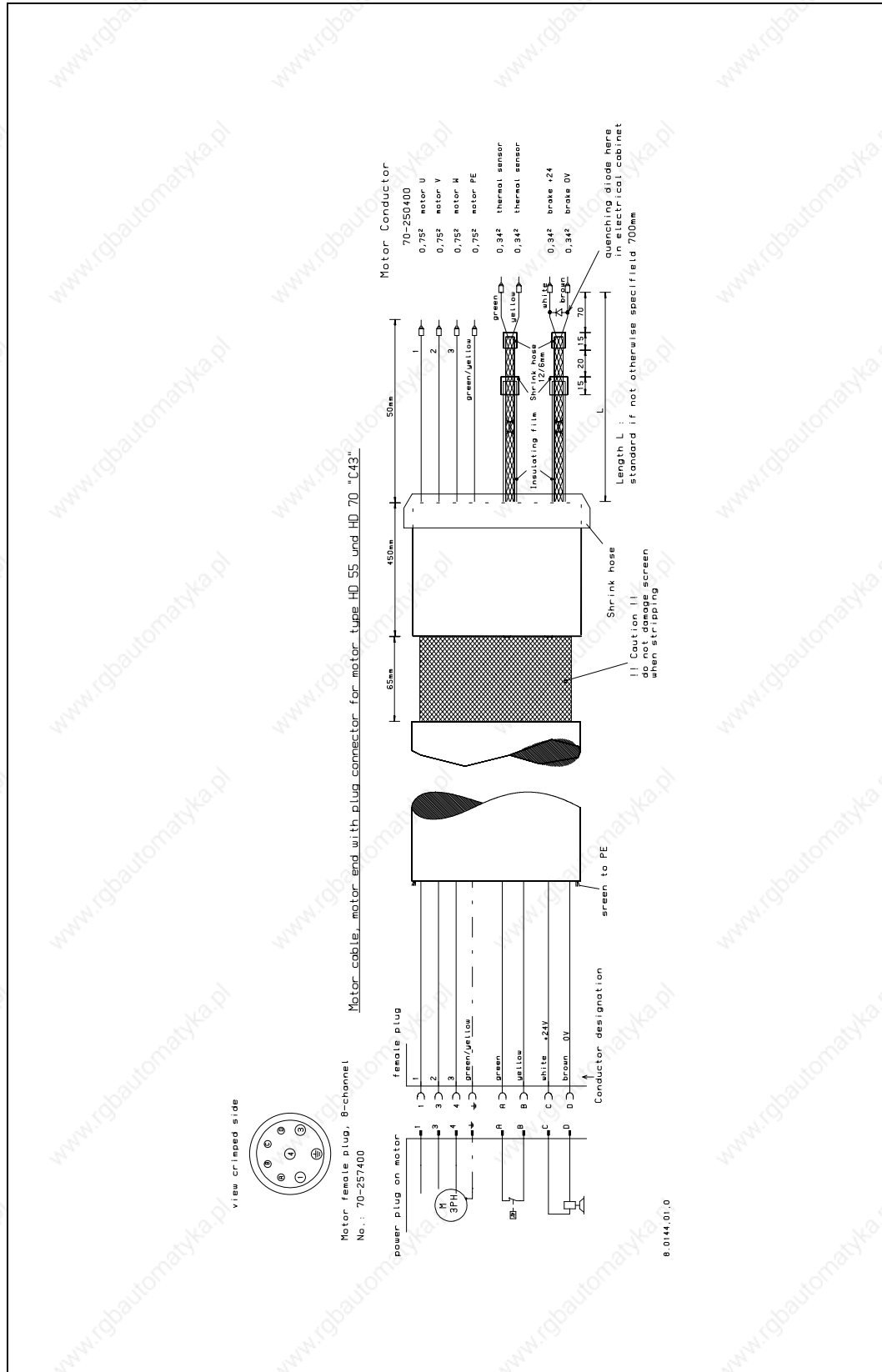

Fig. 11: Motor cable for HD55/HD70 (configuration from May 1998)

For EMC reasons screened leads should be used as motor supply leads which can be earthed **on both sides**. The motor cable must be dimensioned according to the motor performance data and to the cable length. The drag chain-capable motor cable supplied by ferrocontrol contains 4 conductors(U, V, W, PE) for the power supply and 2 control lead pairs separately screened for the brake and the thermal contact or sensor as well as an overall screening. The overall screening must be connected over a wide area to the central PE point.

The motor and three-phase power cables are to be laid spatially separate and in separate cable ducts from electronic cables (resolver).

Notice

The **maximum length** of the motor cables is specified at **50m!** For longer cables additional information must be sought from ferrocontrol.

Technical data for the ferrocontrol motor cable:

Continuous operation temperature	- flexible use	- 30 to +70°C
	- fixed wiring	- 50 to +70°C

DARC 1.0 / 4 x 0.75+2 x (2 x 0.34) ferrocontrol article no.: 99-107617

- | | | |
|------------------|---------------------------|-------------------|
| • Smallest bend | - Alternating stress bend | 150 mm |
| | - fixed wiring | 80 mm |
| • Outer diameter | | 10,7 ± 0,6 mm |
| • Weight | | approx. 0,25 kg/m |

DARC 1.0 / 4 x 1.5+2 x (2 x 0.75) ferrocontrol Article no.: 70-250500

- | | | |
|------------------|---------------------------|------------------|
| • Smallest bend | - Alternating stress bend | 160 mm |
| | - fixed wiring | 90 mm |
| • Outer diameter | | 13,8 ± 0,5 mm |
| • Weight | | approx. 0,3 kg/m |

DARC 1.0 / 4 x 2.5+2 x (2 x 0.75) ferrocontrol Article no.: 70 250600

- Smallest bend - Alternating stress bend 170 mm
- fixed wiring 95 mm
- Outer diameter 14,8 ± 0,5 mm
- Weight approx. 0,4 kg/m

DARC 1.0 / 4 x 6.0+2 x (2 x 0.75) ferrocontrol article no.: 70-250800

- Smallest bend - Alternating stress bend 220 mm
- fixed wiring 120 mm
- Outer diameter 18,8 ± 0,6 mm
- Weight approx. 0,7 kg/m

Conductor cross section	fixed wiring (mm)	Radii for flexible laying (mm)
0.75 mm ²	80	150
1.5 mm ²	90	160
2.5 mm ²	90	170
6 mm ²	120	220

Table 11: Survey: Minimum radii for DARC motor cables 1.x

In addition, motors and accessories for areas in danger of explosion are available as operational equipment with the identification EEx de IIC T4.

3.6.1.2 Network supply cable

Litz wire of type H07V-K can be used for the network supply lead . The following minimum requirements must be observed:

Supply modules	V5	V15
Fuses F1.1 - F1.3 (medium time-lag)	10 A	35 A
Network supply lead[mm ²]	1.5	4
Installation terminal section [mm ²]	2.5	4

Table 12: Supply module network supply cable

3.6.1.3 Resolver cables

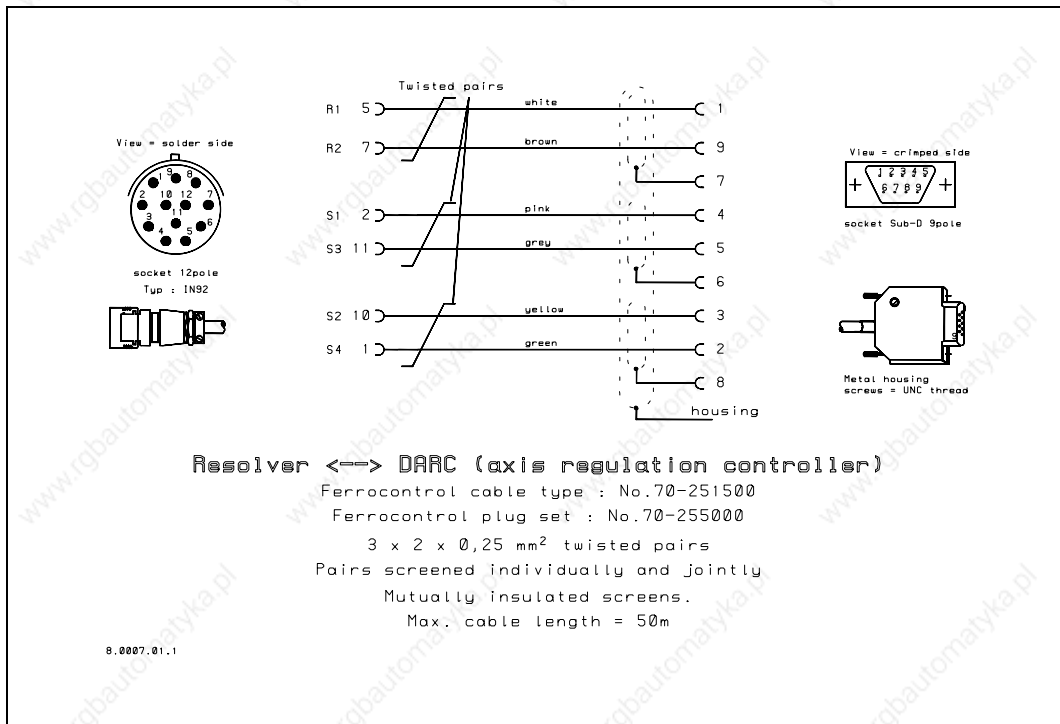

Fig. 12: Resolver cables

A special lead twisted in pairs with three individual and one overall screen must be used to connect the resolvers. This is available from ferrocontrol under the article no. 70-251500.

Resolver cables DARC 1.0 ferrocontrol article no.: 70-251500

- | | |
|---|-------------------|
| • Conductors (in pairs and screened in total) | 3 x (2x0.25) |
| • Continuous operation temperature - flexible use | -30 to +80°C |
| • - fixed wiring | -50 to +90°C |
| • Smallest bend - alternating stress bend | 110 mm |
| • - fixed wiring | 60 mm |
| • Outer diameter | 8.9 ± 0.3 mm |
| • Weight | approx. 0.15 kg/m |
| • Maximum cable length | 50 m |

In addition, motors and accessories for areas in danger of explosion are available as operational equipment with the identification EEx de IIC T4.

3.6.1.4 Absolute value encoder cables

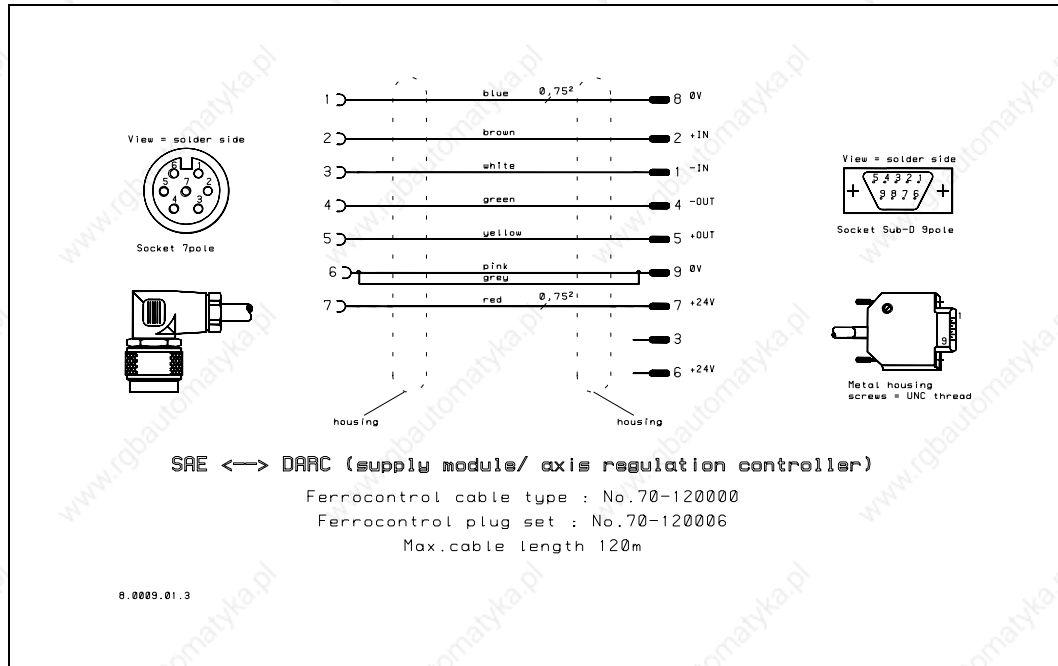

Fig. 13: Absolute value encoder cables

Encoder cable SAE 1.1 ferrocontrol article no.: 70-120000

- Strands 6 x 0.25 in twisted pairs+2 x 0.75 screened in total
- Continuous operation temperature
 - flexible use -30 to +80°C
 - fixed wiring -50 to +90°C
- Smallest bend
 - alternating stress bend 110 mm
 - fixed wiring 50 mm
- Outer diameter 7.0 ± 0.3 mm
- Weight approx. 0.1 kg/m
- Maximum cable length 120 m

In addition, motors and accessories for areas in danger of explosion are available as operational equipment with the identification EEx de IIC T4.

3.6.1.5 Incremental position encoder cables

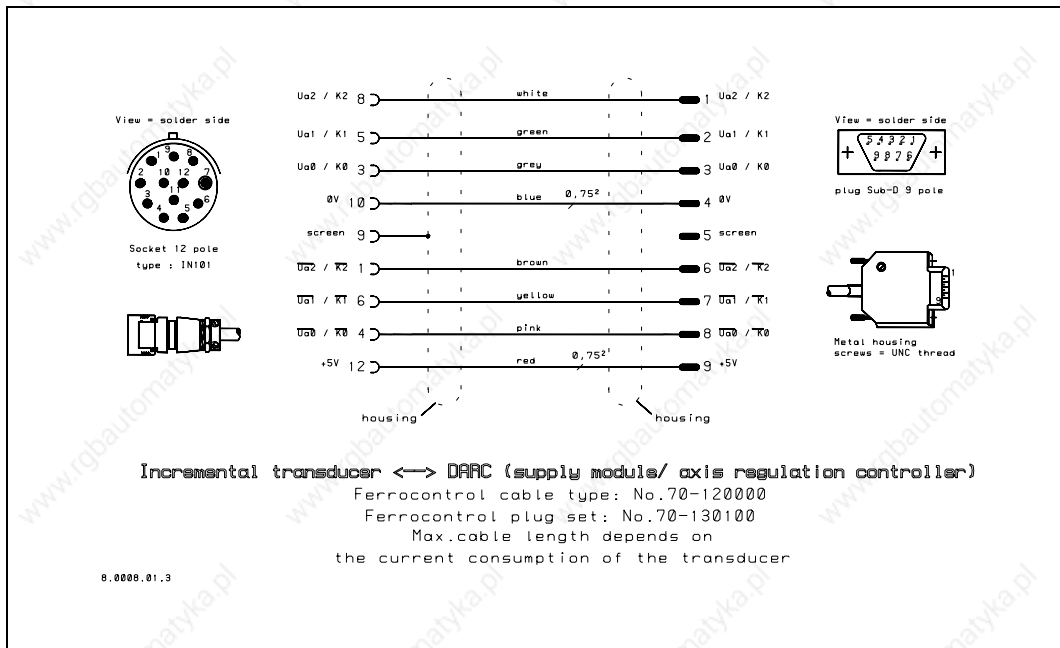

Fig. 14: Incremental encoder cables

Encoder cables SAE 1.1 ferrocontrol article no.: 70-120000

- Conductors 6 x 0.25 twisted in pairs+2 x 0.75 screened in total
- Continuous operation temperature - flexible use -30 to +80°C
 - fixed wiring -50 to +90°C
- Smallest bend - alternating stress bend 110 mm
 - fixed wiring 50 mm
- Outer diameter 7.0 ± 0.3 mm
- Weight approx. 0.1 kg/m
- Maximum cable length encoder-dependent

In addition, motors and accessories for areas in danger of explosion are available as operational equipment with the identification EEx de IIC T4.

3.6.1.6 INC-distributor cable

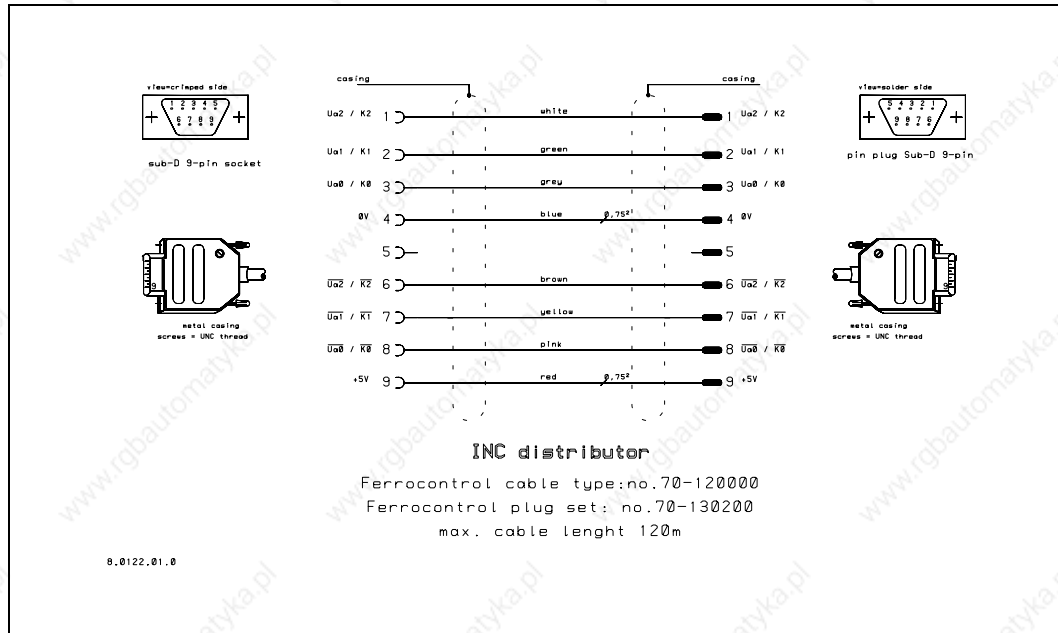

Fig. 15: INC-distributor cables

Encoder cables SAE 1.1 ferrocontrol article no.: 70-120000

- Conductors 6 x 0.25 twisted in pairs+2 x 0.75 screened in total
- Continuous operation temperature
 - flexible use -30 to +80°C
 - fixed wiring -50 to +90°C
- Smallest bend
 - alternating stress bend 110 mm
 - fixed wiring 50 mm
- Outer diameter 7.0 ± 0.3 mm
- Weight approx. 0.1 kg/m
- Max. cable length encoder-dependent (< 120 m)

When using the supply overriding gearing function, this cable is to be used in connection with the INC-distributor (Art. no. 30-251000).

3.6.1.7 Braking resistance and d.c. link choke cable

A litz wire of type H07V-K is to be used for the braking resistance and the d.c. link filter choke. The cables must be twisted together respectively and may **not** be connected to the 400 V mains supply cable. The following minimal requirements must be observed:

Supply modules	V5	V15
Apparatus lead [mm ²]	4	6
Installation terminal section [mm ²]	4	6

Table 13: Braking resistance and d.c. link choke cable

3.6.1.8 D.c. link bridge circuits

Axis regulation controllers set up side by side are connected by three terminal bars, one for the protective conductor and two for the d.c. link voltage, which must be safeguarded against contact by barriers.

Because of different widths of module designs the DARC system requires terminal bars of different lengths.

The following terminal bars can be supplied by ferrocontrol as spare parts (are part of the delivery program of the supply module and the axis regulation controller):

- Terminal bar DARC size 1 L = 71.5 mm, article number 99-106043
- Terminal bar DARC size 2 L = 106.5 mm, article number 99-106044
- Terminal bar DARC size 2 L = 116.5 mm, article number 99-108277

Module Conductor bar	Accessories for Modules S2, S4, S6	Accessories for Modules S9, S12, S18, S25, S35	Accessories for Modules V5, V15
99-106043	X		
99-106044		X	
99-108277			X

Table 14: D.c link bridge circuits

3.6.1.9 Override potentiometer cables

Compare Chapter 3.6.3.

3.6.1.10 RS-232 Service interface cables

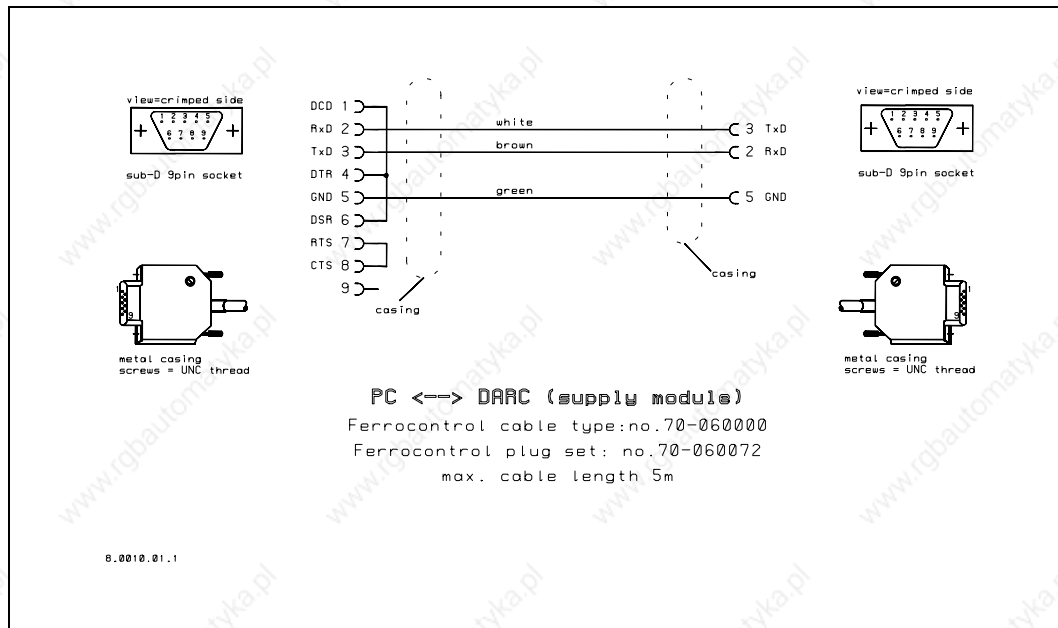

Fig. 16: Service interface cable

The service interface cable is a screened lead between the service interface at the supply module and the serial interface at the PC. If this cable is used it is not possible to connect an override potentiometer.

3.6.1.11 Parallel bus cable

The parallel bus cable is a 26-pin flat cable connection respectively from the axis regulation controller to the spatially neighbouring axis regulation controller nearest to the supply module or to the supply module itself.

There are two different versions available:

- Parallel-conductor coupling for DARC, 5 cm, S2-S6, article number 99-106993
- Parallel-conductor coupling for DARC, 12,5 cm, S9-S35, article number 99-106994

A terminator, available under article number 99-107747, must be plugged onto the parallel bus connection of the axis regulation controller furthest from the supply module.

The parallel bus cable and the terminator are both part of the delivery range of the axis regulation controller or of the supply module. The parallel bus cable may only be replaced by authorized service personnel.

3.6.1.12 Fieldbus cable Profibus-DP

The cable described in the following is the standard cable used with the Profibus system.

Fieldbus cable Profibus-DP ferrocontrol article no.: 70-043800 (trailing cable)

- Strands 2x0.64 screened
- Permanent operating temperature

flexible use	-40 to +60°C
fixed cabling	-40 to +60°C
- Smallest bending radius

continuous flexion	>150 mm
fixed cabling	>75 mm
- Outer diameter 8.0± 0.4 mm
- Weight app. 63 g/m
- Maximum cable length

100 m at 3 - 12 MBit/s
200 m at 1.5 MBit/s
400 m at 500 kBit/s
1000 m at 187.5 kBit/s
1200 m at 9.6, 19.2, 93.75 kBit/s

3.6.1.13 Fieldbus plug Profibus-DP

ferrocontrol supplies three different plug types for networking the Profibus-DP.

- Profibus-DP plug with horizontal screw connection (with integrated terminators) article no.: 70-044000
- Profibus-DP plug with horizontal screw connection (nodes without integrated terminators) article no.: 70-043900
- Profibus-DP plug with horizontal screw connection (nodes without integrated terminators, with programming interface) article no.: 70-044100

3.6.1.14 Fieldbus cable CAN bus

The cable described in the following is the standard cable used in the CAN bus system for fixed cabling and energy chain operation.

Fieldbus cable CAN bus 1.0 ferrocontrol article no.: 70-043500

- Strands 2x0.50, 1x0.50 screened
- Permanent operating temperature

flexible use	-40 to +70°C
fixed cabling	-40 to +70°C

- | | |
|---|--|
| <ul style="list-style-type: none"> • Smallest bending radius • Outer diameter • Weight • Maximum cable length | continuous flexion 70 mm
fixed cabling 50 mm

≤8.0 mm

app. 80 g/m

40 m at 1 MBit/s
100 m at 500 kBit/s |
|---|--|

The maximum cable length is not only limited by the baud rate, but at lengths greater than 300m the conductor resistance limits the maximum possible cable length. The possible cable lengths for different cable types can be read from the following table.

Cable type	Conductor resistance	Max. Length	
		k = 32	k = 64
Fieldbus cable CAN bus 1.0 ferrocontrol (0.5mm ² or AWG20)	< 40 Ω/km	360m	310m
0.75mm ² oder AWG18	< 30 Ω/km	550m	470m
DeviceNet™ (thin cable) or ISO 11898 cable	< 70 Ω/km	200m	170m
DeviceNet™ (thick cable)	< 20 Ω/km	800m	690m
1.00mm ² or AWG17	< 17 Ω/km	1200m	1000m

Table 15: Maximum bus cable length for different CAN cables and number of nodes (k)

3.6.1.15 Fieldbus plugs CAN bus

ferrocontrol supplies three different plug types for networking the CAN-bus.

- CAN plug with horizontal screw connection (with integrated terminators) article no.: 70-043700
- CAN plug with horizontal screw connection (nodes without integrated terminators) article no.: 70-043600
- CAN plug with horizontal screw connection (nodes without integrated terminators, with programming interface) article no.: 70-043701

3.6.1.16 Module bus cable (MOBus)

Fig. 17: Module bus cable (in preparation)

In one of the following versions of this documentation, the module bus cable (for plug X13) will be described at this point.

Notice

The module bus cable for the DARC system can only be used with a CAN bus interface with SeleCAN- or CANOpen protocol and integrated SPS functionality.

3.6.1.17 Module bus interface (MOBus)

Fig. 18: Module bus interface (in preparation)

In one of the following versions of this documentation, the module bus cable (for plug X13) will be described at this point.

Notice

The module bus cable for the DARC system can only be used with a CAN bus interface with SeleCAN or CANOpen protocol and integrated SPS functionality.

3.6.2 Encoder systems

3.6.2.1 Incremental position encoder

Two different incremental position encoder types with 1000 and 2500 increments per revolution are used. These are available under the article number 30-080500 or 30-081000. Further details can be found in Chapter 4.4.1.6 or can be requested from ferrocontrol.

3.6.2.2 Absolute value encoder

Six different absolute value encoder types with SSI interface are used; three with 1024 or 4096 steps per revolution in single turn or multiturn version with 1, 64 or 4096 revolutions respectively.

Absolute value encoder type	Article number
SAE 1020H 1024 * 1	30-100300
SAE 1020H 1024 * 64	30-100400
SAE 1020H 1024 * 4096	30-100500
SAE 1020H 4096 * 1	30-100000
SAE 1020H 4096 * 64	30-100100
SAE 1020H 4096 * 4096	30-100200

Table 16: Available absolute value encoders for the DARC system

Further details about the SSI interface, the mechanical dimensions and encoder accessories can be found in Chapter 4.4.1.6 or can be requested from ferrocontrol.

3.6.2.3 INC-distributor

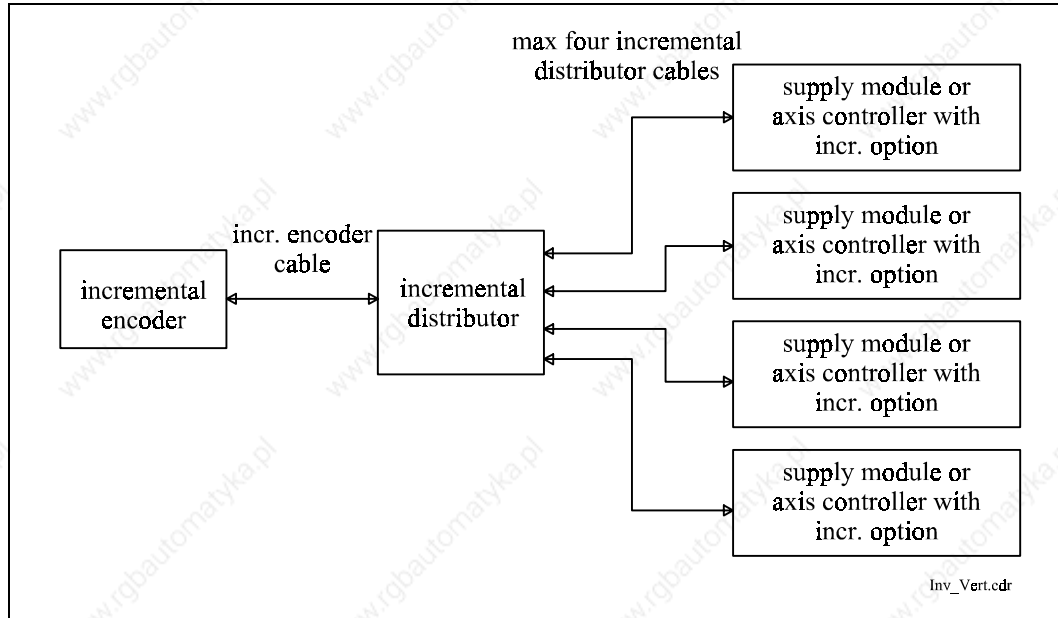

Fig. 19: INC-distributor

The INC distributor (Art. no. 30-251000) is used with the supply-overriding gearing function (synchronous motion).

You can find further information about the technical data in the product documentation available with the INC-distributor.

3.6.3 Override potentiometer

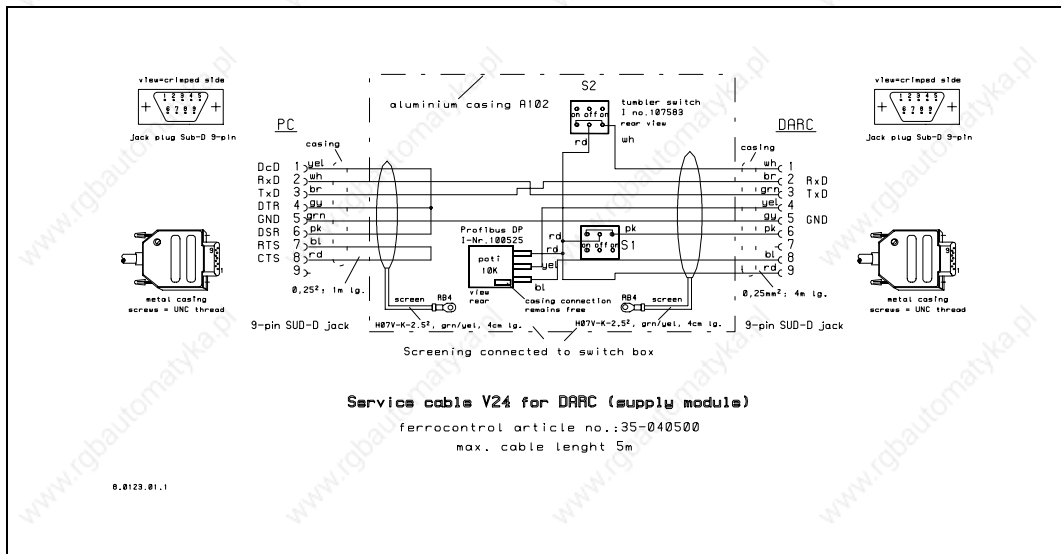

Fig. 20: Override potentiometer cable

The override potentiometer for limiting the feed rate is delivered as a complete installation consisting of a housing with a built-in potentiometer and screened lead (5 m) with one connection plug each for the service interface at the supply module and the PC connection. This equipment is available under article no. 35-040500.

The potentiometer has the following values/characteristics:

$R = 10 \text{ k}\Omega$ linear

$P_{\text{max}} = 2 \text{ W}$

6 mm - axis, metal, enclosed

An isolation amplifier should be used if the cables are longer than 5 m.

Notice

If you only want to use the override potentiometer, you will find further information in Chapter 4.4.1.8.

3.6.4 Braking resistors

Notice

Information about the dimensions of the braking resistors can be found in the appendix of this document.

There are three braking resistor models of different performance classes available for the two performance classes of the supply modules V5 and V15.

Supply module	V5	V15
Available resistors	$R_{min}=33 \Omega$ Art. No. 35-058400 (300 W) Art. No. 35-058300 (110 W)	$R_{min}=16 \Omega$ Art. no. 35-058500 (300 W)

Table 17: Available braking resistors

Selection of the braking resistance for the supply module V5 depends on its application.

3.6.5 D.c. link filter choke

There are two different d.c. link filter chokes available for the two performance classes of the supply modules which can be ordered under the article numbers given under the respective diagrams.

Notice

Information about the dimensions of the d.c. link filter choke can be found in the appendix of this document.

3.6.6 Mains filter for 24 V power supply

ferrocontrol provides a mains filter for the 24 V power supply as an external filter element. The system EMC in accordance with the design specifications can only be guaranteed with this filter.

This filter is available under article number 60-000500. It is used as protection against interference voltage from the 24 V power supply and at the same time possible interference voltage produced in the device are considerably reduced and do not get back into the supply network. The outputs for the electronic power supply are on the PE connection side (load side), the inputs for the 24 V power supply are on the other side (compare Fig. 72).

Notice

You can find information about the dimensions and connections of the mains filter in the appendix of this document.

3.6.7 EMC screw connection for the motor

As an additional protection against EMC interference on the motor cable ferrocontrol supplies an EMC screw connection on the motor side an.

This EMC screw connection is available under the following article numbers:

EMC screw connection	SVHE 16/16/15/11 (PG 16)	SVHE 21/16/16/12 (PG 16)	SVHE 21/21/20/16 (PG 21)
Article number	99-109185	99-109186	99-108518
Motor conductor cross section	1.0 / 1.5 mm ²	1.0 / 2.5 mm ²	1.0 / 6 mm ²
attainable protection class of screw connection	IP 65 - IP 68	IP 65 - IP 68	IP 65 - IP 68

Table 18: EMC screw connection

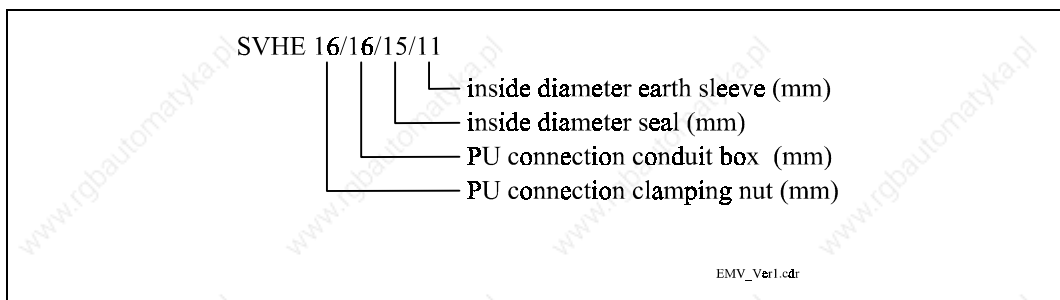

Fig. 21: Dimensions of EMC screw connection

A screw connection is not necessary for the conductor cross section 0.75 mm^2 as the motor cable is fitted with a plug on the motor side.

3.6.8 Screen connection terminals

ferrocontrol provides various connection terminals for connecting the screens of the supply leads to the DARC system in the switching cabinet. These should be screwed to the mounting plate (compare Chapter 4.3). The following screen connection terminals are available for different conductor cross sections:

Screen connection terminal	Article number
for 2 * 2-6 mm ²	99-108472
for 1 * 3-8 mm ²	99-107124
for 1 * 3-8 mm ² for base mounting	99-108562
for 1 * 4-13.5 mm ²	99-106777
for 1 * 10-20 mm ²	99-106778

Table 19: Screen connection terminals

Further accessories for EMC- suitable wiring of switching cabinets can be requested from ferrocontrol.

This page remains blank for technical reasons

4 Installation

ferrocontrol AC servo-drive technology with the DIGITAL AXIS REGULATION CONTROLLER "DARC" was designed according to the latest state and the recognized rules of technology. It corresponds to the relevant fundamental safety specifications. However, its use can cause dangers to the life and limb of the user or to third parties or damage to the machine or property. The DARC system and the AC servo drives must be operated as specified when installed into machines and installations. Usage according to specifications requires that:

- all work on the electrical fitting of the machine/plant is carried out by a qualified electrician or by persons under the instruction and supervision of a qualified electrician in accordance with the technical regulations!
- attention is paid to the notices in this operating manual and in other technical documents of the DARC system.
- the machine/plant is used according to its operating instructions and is in technically perfect condition.

In the following chapter all the necessary information for a professional installation of the DARC system is provided.



Warning

In order to minimize the risk of accident, the installation may only be carried out by trained experts!

4.1 Mechanical installation

The electronic equipment of the DARC drive system is safeguarded by comprehensive safety measures. Fundamental rules must be observed, however, during installation. The following points must be observed when fitting the supply modules and the digital axis regulation controller:

- The DARC system may only be mounted vertically with the mains connections facing downwards.
- The supply module and the axis regulation controller must be mounted as shown in Fig. 6.

- The assembly layout of the axis regulation controllers must be carried out in such a way that the one with the least power is mounted furthest from the supply module.
- In order to guarantee sufficient cooling, a space of 100 mm must be left free above and below the DARC equipment. Braking resistors, input and output chokes must be placed outside the minimum free space of the supply and axis regulation modules. The braking resistors must be put in a well-ventilated place; if necessary on the roof of the switching cabinet. The maximum permissible cable length may not be exceeded.
- Cooling air must be allowed to enter and exhaust air to be emitted without being impeded.
- Built-in equipment may not be exposed to damp.
- In order to prevent condensation, the inside temperature of the switching cabinet should be at least 2° C above the external temperature.
- When coolers are used in switching cabinets, please wait until condensation has evaporated before commissioning if the apparatus has been brought from the cold into a warm area, for example.
- The degree of protection of switching cabinets must be selected so as to ensure that condensation and dust accumulation can be prevented. If necessary, fans and filter mats should be provided. Condensation should only occur occasionally when the apparatus is not in operation (DIN VDE 0160 E, Dec. 90).
- Switching cabinets with electronic equipment should not be left open for any length of time in polluted air.
- Sufficient casing by means of seals should be provided.
- Where the air is polluted (dust, shedding, corrosive gases), which could impair the functioning of the DARC system, sufficient measures to combat this must be taken, e.g. separate fans, built-in filters, regular cleaning.
- Additional measures may be necessary if water-soluble or conductive contaminants are present in the room air.
- If no information to the contrary has been given concerning the permitted ambient temperatures, the following is valid: storage temperature: -25 to +55°C / operating temperature: 0 to +45°C.
- If the DARC system is exposed to vibrations or shaking, vibrations dampers may be necessary.
- Motors, gears and electronic equipment may not be exposed to any excessive shock stress.

4.2 Electrical installation

- The DARC system contains electrostatic-sensitive components. Before assembly and service tasks are carried out in the vicinity of the connector terminals, personnel must be free of electrostatic charges. This applies to the service technician's body, the soldering iron and other tools. Discharge is brought about by touching the PE fastening screw beforehand or another earthed metallic surface in the switching cabinet.
- Electronic components, e.g. spare parts, must be stored in conductive packaging until they are required.
- If you use residual current protection equipment: the DARC system has an internal mains rectifier available. Therefore, after an earth contact, residual d.c. current can prevent the residual current protection equipment from being set off. Additional measures such as earthing must be taken, or universal current-sensitive FI safety switches (VDE 0160/ 05.88) must be used. Please note: when measuring the breaking current of FI safety switches, capacitive compensating currents of the line screens and screen filters can cause spurious release.
- The regulations concerning the minimum cross section of PE conductors must be observed at all costs. The cross section of the PE conductor must be at least as large as the cross section of the power connections.
- Earth wires (0 V) for preventing potential differences should not be looped from device to device but should be wired in star shape. The star point from which the individual conductors are to be routed over the shortest distance to the individual items of equipment should be in the geometrical centre of the switching cabinet.
- Earthing: In order to prevent operational malfunctions earth loops and meshing should be avoided. Protective conductors and earths to the individual modules should be laid in star shape, i.e. going out from a central point and connected from there to the network earth. Please ensure that external encoders never have electrical contact to the motor (or to the housing).
- The inputs may only be supplied with the listed nominal voltages.
- The low-voltage area (24 V) must be sufficiently insulated from the mains voltage, the d.c. link circuit and the motor voltage.
- To ensure efficient radio-interference suppression, the axis regulation controllers, the supply modules and mains filters should be HF-earthed. Please ensure there is a large-area metallic contact between the zinc-plated metal of the switching cabinet (without paint) and the back of the equipment frame.
- The correct drive dimensioning should ensure that the axis regulation controllers and the drives are not exposed to any inadmissible rise in temperature. However, overheating of an axis regulation controller or a motor because of contamination of the cooling system cannot be ruled out.

- Therefore, the motor and the axis regulation controller are monitored by temperature sensors. Excess temperature is registered in the overriding controller as a status. If the controller doesn't react accordingly within a certain time (30 s), this status becomes an error which causes the appropriate drives to be switched off. In addition, the regulator temperature is displayed on the screen in °C in the service in the dialog "Move axis".

4.3 EMC measures in the DARC system

Notice

The DARC system guarantees the observance of the legal requirements concerning interference immunity and emitted interference. The guidelines for class A for industrial installations are adhered to. Further information about EMC examination of the DARC system is available from ferrocontrol.

EMC signifies the ability of an electronic apparatus to function without error in predefined electromagnetic surroundings without influencing the environment in an inadmissible way.

Notice

You can find general information about electromagnetic compatibility in Register 4 of this documentation.

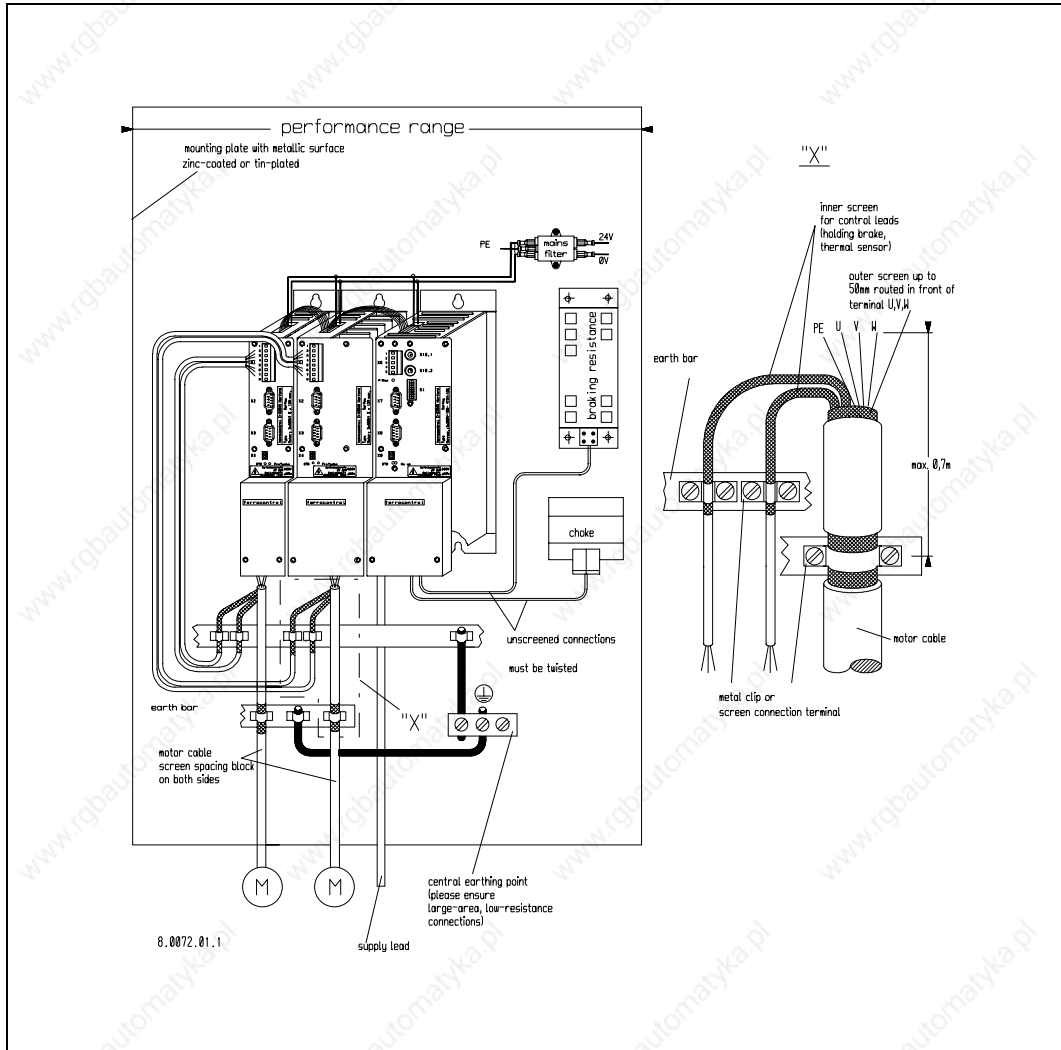

Fig. 22: EMC aspects for switching cabinet construction with the DARC system

4.3.1 Equipment fastening

- For the HF earthing mounting plates with very good conductive surfaces are to be used (e.g. galvanized surface).
- When several mounting plates are used they must be conductively connected over a large area (if necessary using earthings).
- If mounting plates are used with poorly conductive surfaces (e.g. enamelled, anodized, yellow-passivized) the paint or the surface coating on the contact area of the mounting plate to the DARC system, the terminal bars, the mains filter and the screen connections must be removed so that a large-area electrically conductive connection can be made.
- The DARC system, the mains filters and the screen connections must be contacted over a large area with the earthed mounting plate.

4.3.2 Motor leads

- The motor leads must be screened and routed below the axis regulation controller to the mounting plate.
- The screens in the motor cable of the brake and thermal sensor leads must also be connected over a large area to the mounting plate.
- The PE lead of the motor cable must be connected to terminal X5.
- Unscreened terminals should be kept as a short as possible.

4.3.3 Power terminals

- The mains supply lead must be screened and routed to the mounting plate below the supply module; the screen connection must be connected over a large area to the mounting plate (see also Figures)
- Unscreened terminals should be kept as a short as possible.
- The PE lead of the power supply lead must be connected to terminal X11.
- If litz wire of type H07V-K is used the conductors must be routed over the shortest distance to the cable duct where they must be laid.

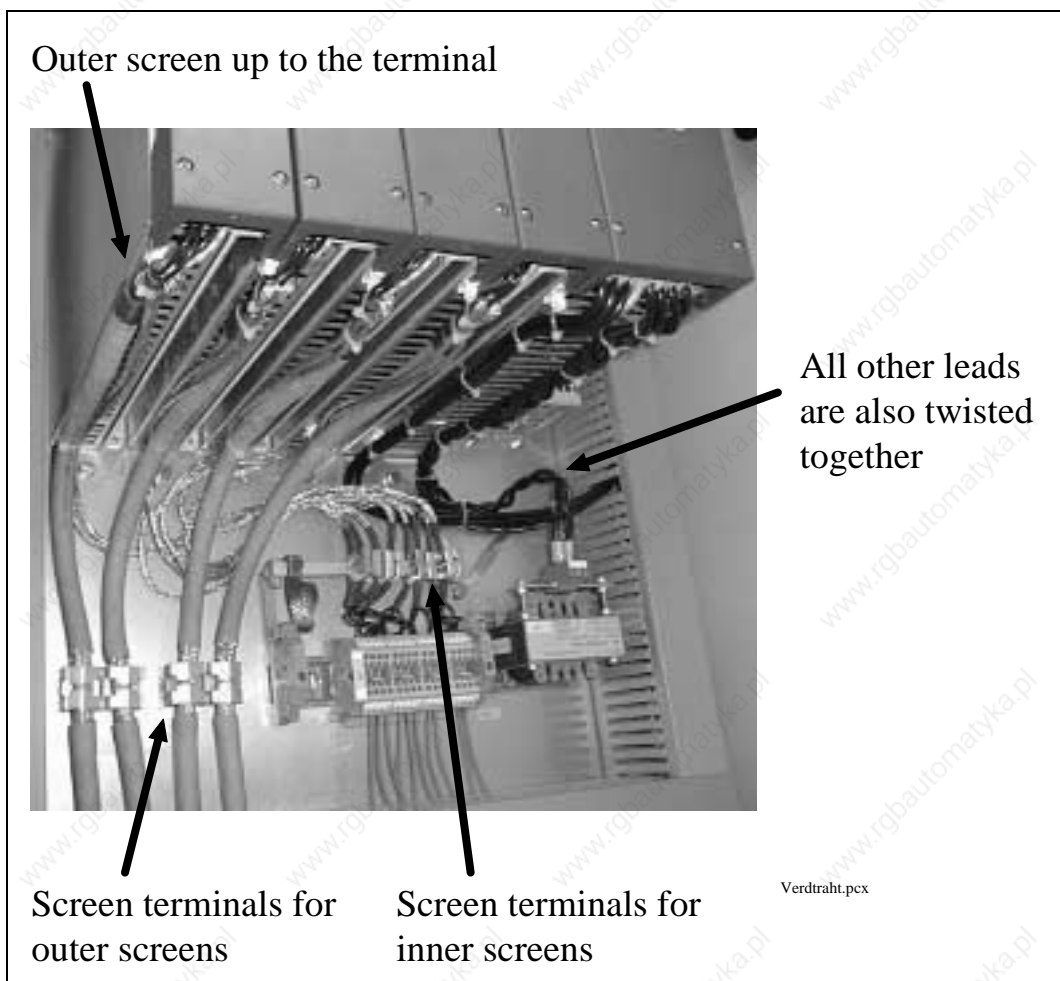

Fig. 23: Detail photo power connection on the DARC system

4.3.4 Motor connection

The motor cable must be connected to the motor terminal box by a so-called "EMC screw connection" of the right size. Please make sure that the contact sleeve of the screw connection between the inner jacket and the outer screen of the motor cable is bonded all around (see Fig. 25).

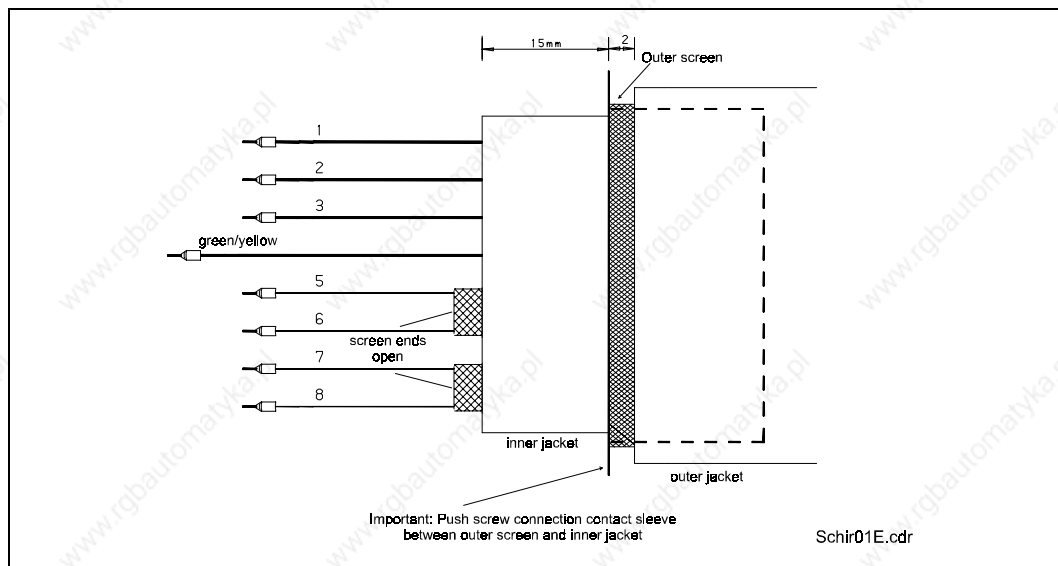

Fig. 24: DARC cable for connecting the motor

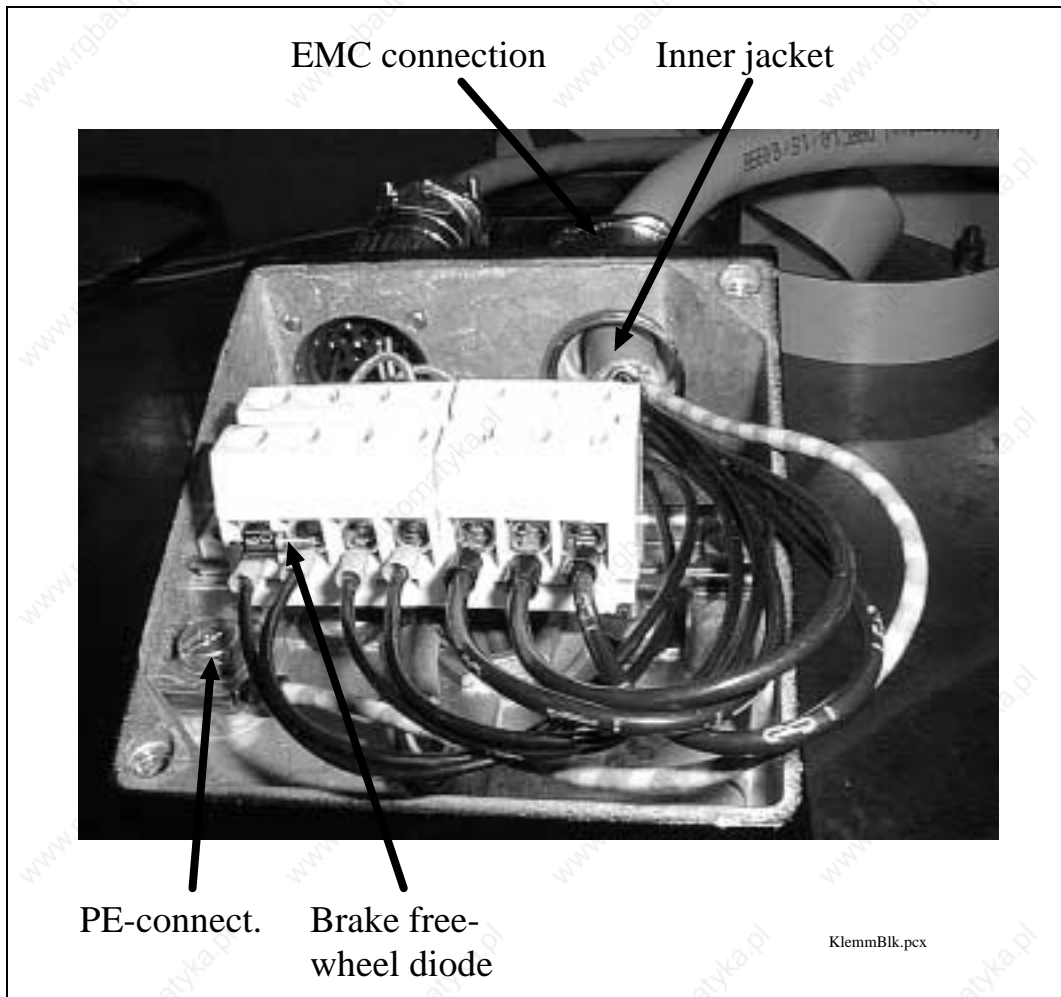

Fig. 25: Detail photo motor terminal board

4.3.5 Fieldbus connection and other control leads

The fieldbus connection must have a large-area screen contact which is made over the shortest distance (directly beside the plug), even if this is done in the plug. To do this, the screening of the fieldbus cable is connected by a screen terminal to the galvanized mounting plate (see Fig. 26).

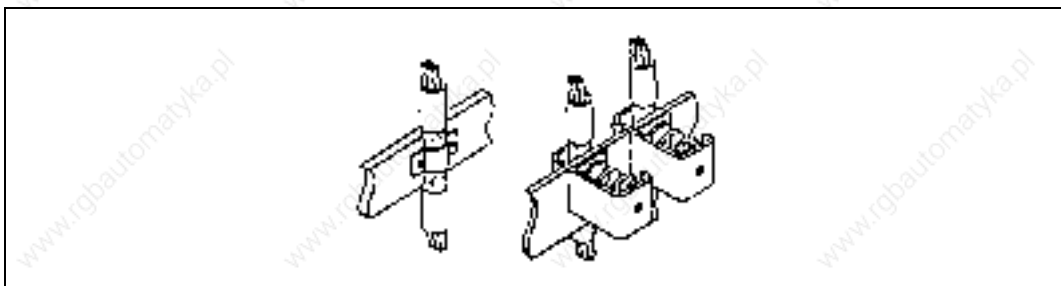

Fig. 26: Large-area screen connection with screen terminals

4.3.6 Filter measures

ferrocontrol supplies a filter as an external filter element. Only by using this filter is the EMC of the system guaranteed in accordance with the design specifications.

This filter is available under article no. 60-000500. It is used as a protection against interference voltage from the 24 V DC power supply and simultaneously possible disturbance voltage produced in the equipment is considerably weakened and doesn't get into the supply network.

A 400-V mains filter for the supply module is not necessary (for radio interference suppression grade A), as this is already integrated into the machine. If radio interference suppression grade B is required, an additional filter must be used.

4.3.7 Encoder connection

For all encoder types (resolver, SAE encoder, incremental encoder) screened leads must be used.

SAE encoders, incremental encoders must be earthed at both ends over a large area with screen terminals (see above). Only if well-earthed plug casings are used can the additional PE contact on the corresponding cable side be left out. The resolver cable may not be earthed on the motor.

4.3.8 Screening

Screening, chassis earth connections (GND) and earth potential connections (PE) must be wired with particular care in order to prevent emitted interference.

- Motor, encoder and fieldbus leads of the DARC system must always be screened.
- Screenings (braided screens) should not be interrupted, if possible.
- In the case of interruptions, the screenings must be fastened at both ends over a large area by means of a screen connection (screen terminal) to the mounting plate.
- If possible, control leads should not be laid parallel to motor leads affected by interference.
- The cabling should be laid as near as possible to the reference potential (freely hanging leads act as aerials) (see Fig. 27).

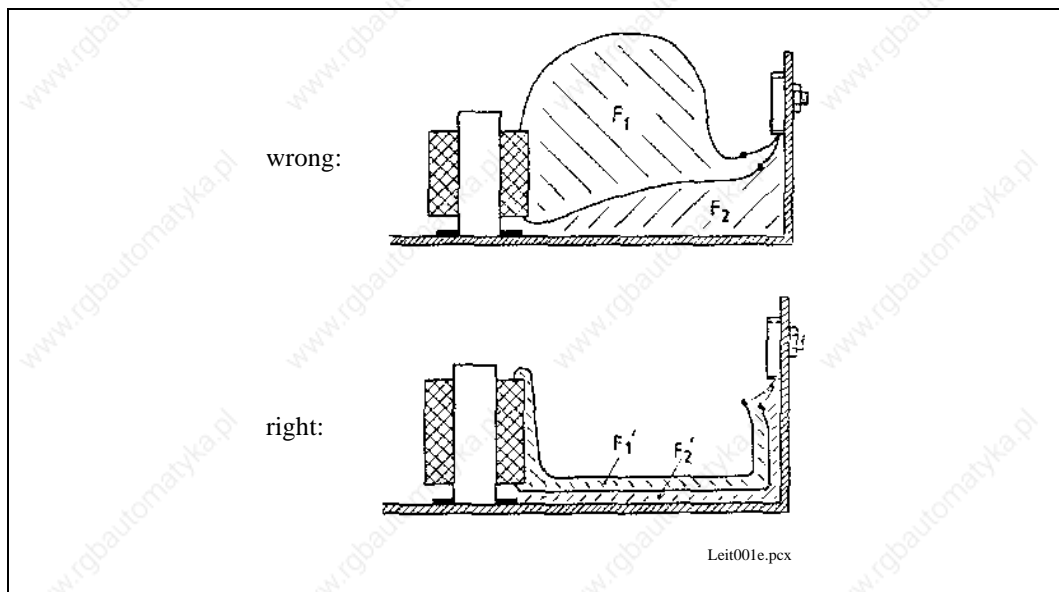

Fig. 27: Laying of individual strands

4.3.9 Earthing

- Please ensure good equipotential bonding of all system components by means of leads from a central earthing point (PE bar).
- Please ensure the prescribed minimum cross sections are observed.
- Please make sure that no external equipment is damaged by the control electronic earthing.

4.4 Connections

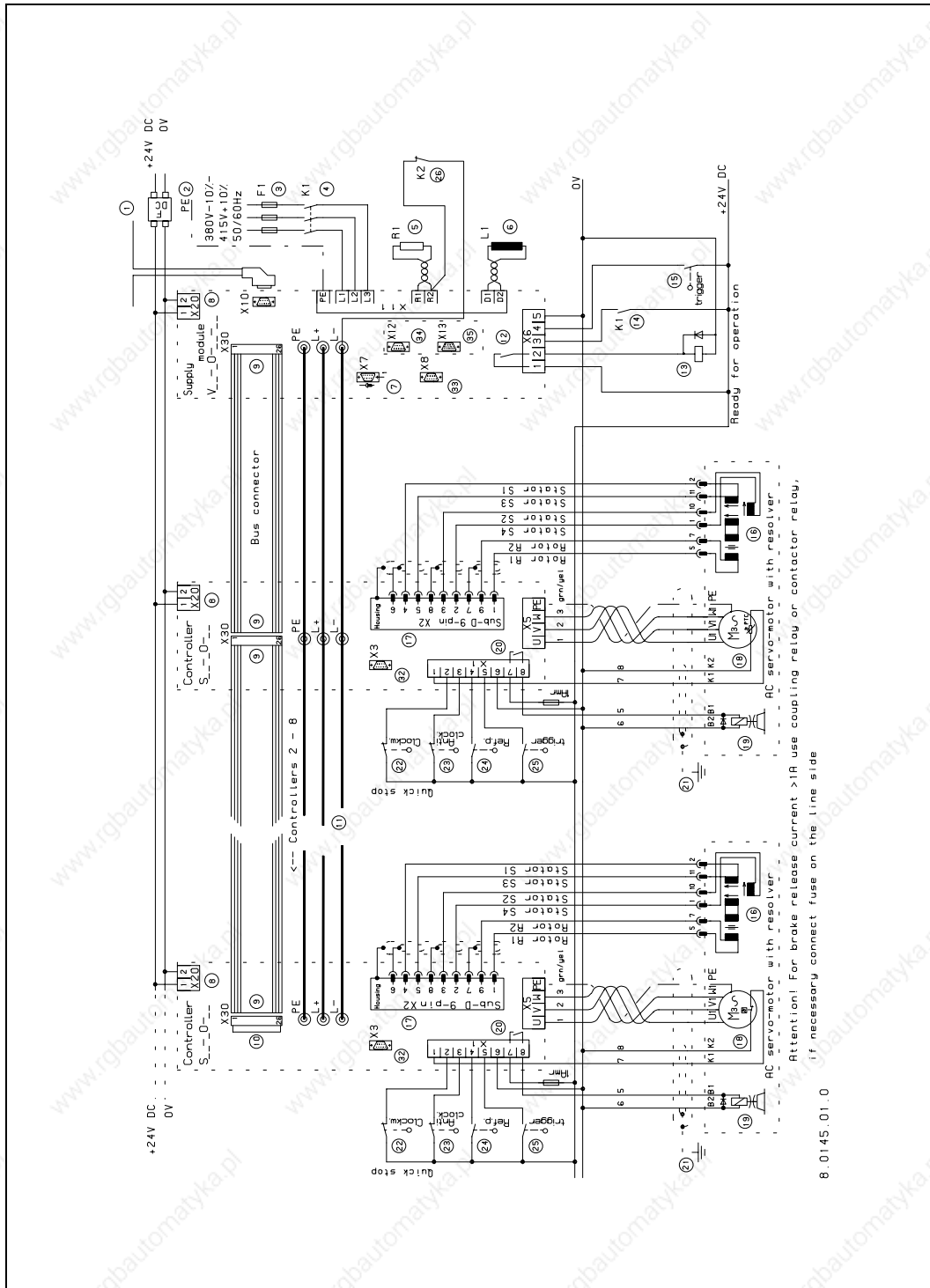

Fig. 28: Terminal connection diagram DARC system

The DARC system offers comprehensive, powerful interfaces to its surroundings. These are described in detail in the following, starting with an overall survey followed by a description of every available interface.

The component/module identification corresponds to those in Fig. 28, Fig. 56 and Fig. 57.

Encircled numbers in the terminal connection diagram DARC system (Fig. 28)

- 1 Fieldbus connection (terminal X10)
- 2 PE terminal power supply (terminal X11)
- 3 Input to network / fusing (terminal X11)
- 4 Power system protection (terminal X11)
- 5 Braking resistor (terminal X11)
- 6 D.c. link filter choke (terminal X11)
- 7 Service plug, 9-pin sub-D jack (terminal X7)
- 8 24 V DC power supply for internal signal processing (terminal X20)
- 9 Parallelbus connector (terminal X30)
- 10 Terminator bus connector (terminal X30)
- 11 D.c. link bridges (terminal L+, L-, PE)
- 12 Control in- and outputs (terminal X6)
- 13 Auxiliary relay BTB power supply (to terminal X6)
- 14 Enabling (to terminal X6)
- 15 24 V DC trigger signal (to terminal X6)
- 16 Resolver (to terminal X2)
- 17 Resolver plug (terminal X2), resolver lead
- 18 Temperature monitoring of the servomotor (at terminal X1)
- 19 Holding brake (at terminal X1)
- 20 Peripheral equipment and holding brake (terminal X1)
- 21 Screening motor cable (at terminal X1)
- 22 Switch quick-stop clockwise (at terminal X1)
- 23 Switch quick-stop anti-clockwise (at terminal X1)
- 24 Reference point switch (at terminal X1)
- 25 Trigger switch (at terminal X1)

- 26 D.c. link short-circuit contactor (at terminal X11)
- 32 Optional (2nd) encoder interface INC or SAE for the loop controllers
- 33 Optional (2nd) encoder interface INC or SAE for the supply module
- 34 Prog/user interface for CAN bus (terminal X12)
- 35 MOBus interface for CAN bus (terminal XC13)

Encircled numbers in the figures: switching suggestions for hardware-based stoppage of the drives (Fig. 57, Fig. 58, compare Chapter 4.5.1)

- 27 D.c. link short-circuit resistor (braking resistor)
- 28 Limit switch
- 29 Delayed-release timing relay
- 30 Motor-winding short circuit
- 31 Control voltage

4.4.1 Supply module

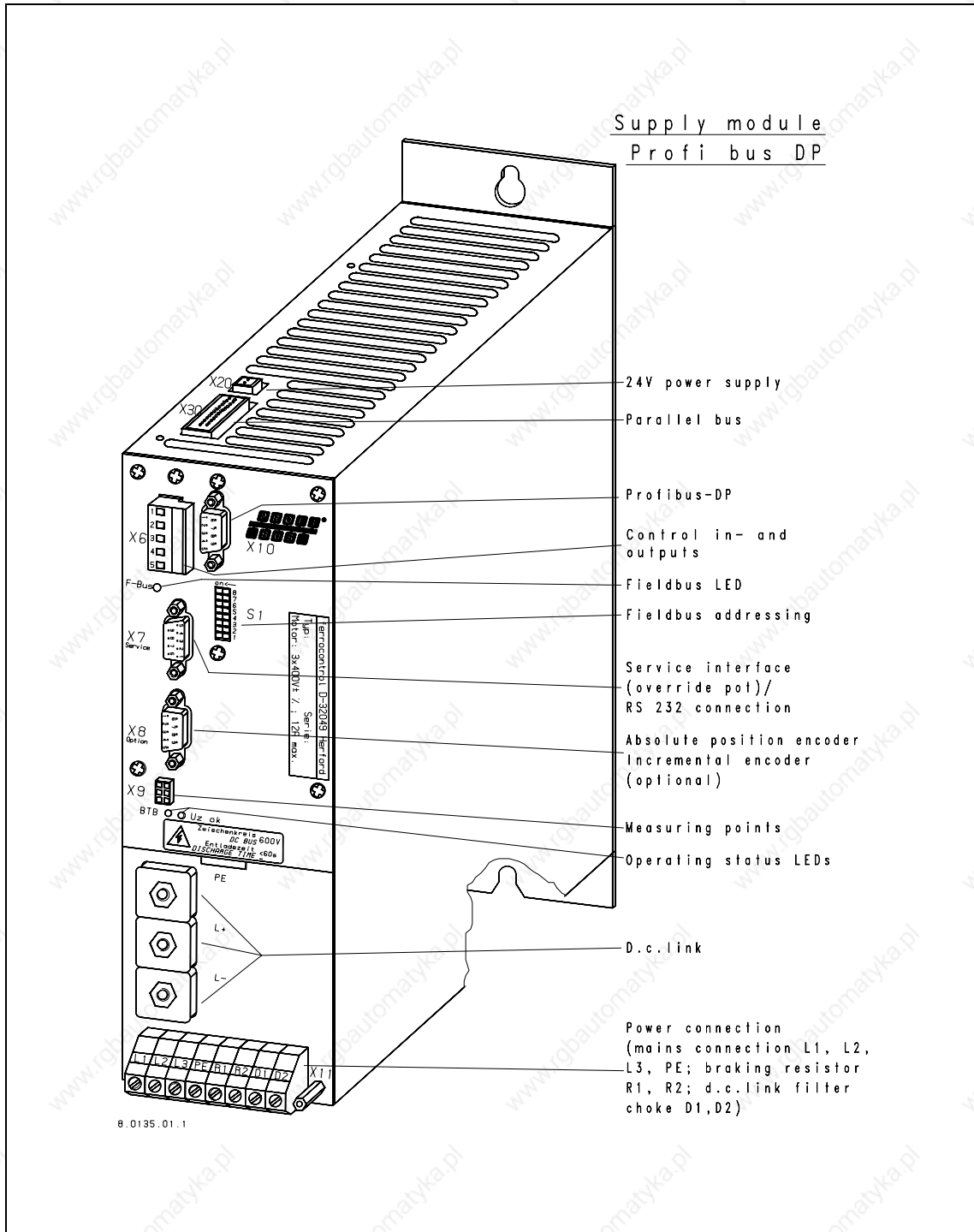

Fig. 29: Connections of the supply module with Profibus-DP

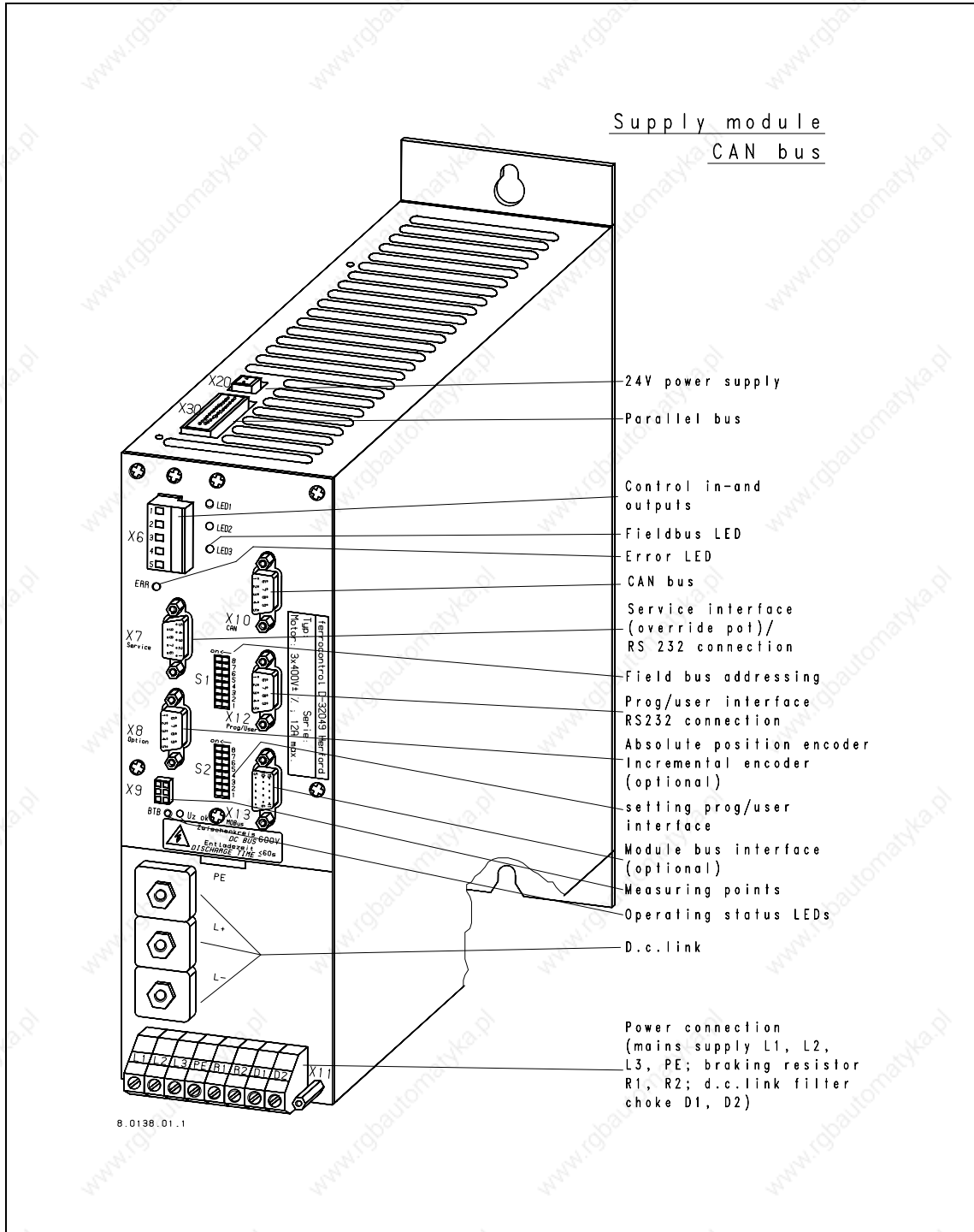

Fig. 30: Control in- and outputs

4.4.1.1 Power terminal (terminal X11)

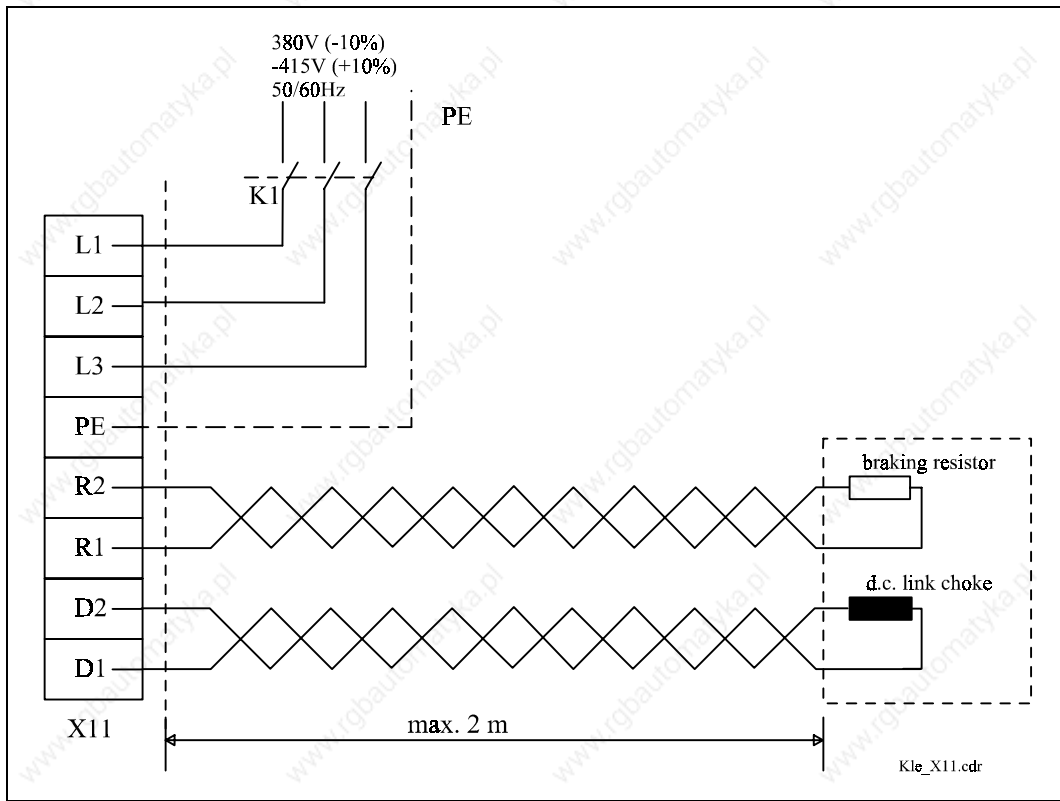

Fig. 31: Power terminal

- Select the lead cross section of the mains supply lead according to Chapter 3.6.1.2
- Connect the mains supply lead to the screw terminals L1, L2, L3, PE. All axis regulation controllers and supply modules must be earthed on a common star point with a conductor cross section of at least 6 mm².
- The nominal voltage range is: 3 x 380 V - 10% - 415 V+10%, 50/60 Hz.
- The mains supply lead fusing must be laid according to the respective motor or axis regulation controller connected (compare Table 20). It is possible to use thermal motor protecting switches.

Supply modules	V5	V15
Fuses F1.1 - F1.3 (medium time-lag)	10 A	35 A
Mains supply lead [mm ²]	1.5	4
Apparatus terminals[mm ²]	2.5	4

Table 20: Supply module connections (terminal X11)

- Connect the screen to the screen connection.
- Connect the external braking resistor (bleeder), which converts the energy recovered during braking into heat, to the screw terminals R1, R2. **Please ensure that the installation is safe to touch!** The d.c. link voltage (U_Z) is limited to a maximum of 700 V by a brake chopper. The layout is according to Chapter 3.6.4. If the d.c. link voltage exceeds 700 V, the braking resistor between the connections L+ and L- is internally switched through until the voltage has been reduced to a level under 677 V (two-position controller).
- Connect the d.c. link filter choke to the screw terminals D1, D2. It serves to smooth the d.c. link voltage, to decrease the harmonic content and to relieve the input rectifier. **Please make sure that the installation is shockproof!**

4.4.1.2 D.c. link circuit (Bridge L+, L-, PE)

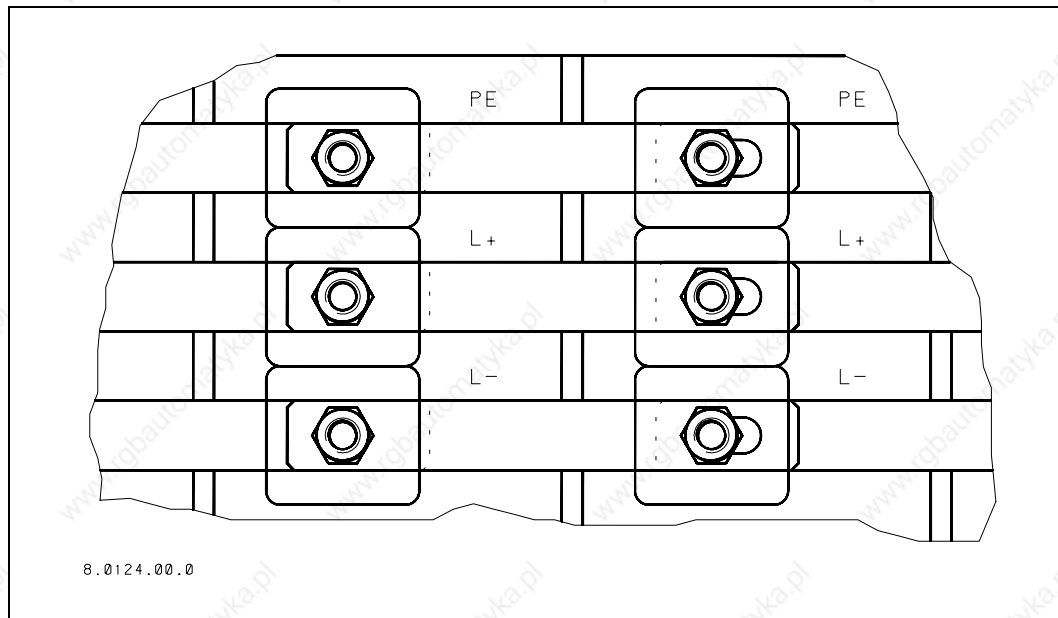

Fig. 32: D.c. link bridges

- The function of the bridges is the parallel connection of the d.c. link circuit and the PE terminals. They are included in the delivery package of the axis regulation controllers in the appropriate length.
- Bolt the connecting bridges between the supply module and the axis regulation controllers.
- Screw the grey barriers with the ferrocontrol imprint as a shock protection onto the supply module and the axis regulation controllers.

4.4.1.3 24 V power supply (Terminal X20)

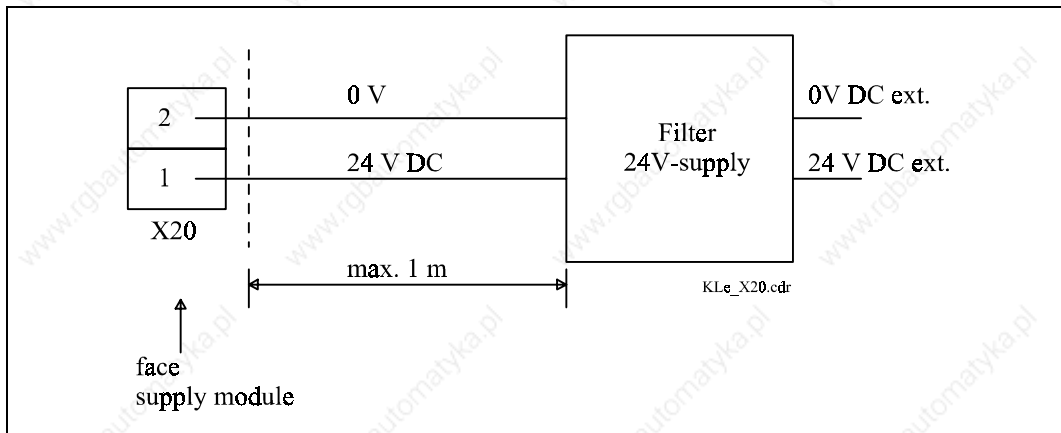

Fig. 33: 24 V power supply

- Connect the 24 V DC power supply to terminal X20, which is in the plug-in version. The permitted voltage tolerance is: 18 - 28 V. Use the filters given above (compare Chapter 0).
- Choose the lead cross section with at least 0.75 mm² (load-dependent).
- The 24 V power supply must be installed before the mains supply and may not be switched on during operation (this is guaranteed by the relay at terminal X6.2).
- Power consumption supply module : 400 mA (V5), 600 mA (V15), plus 200 mA respectively with optional encoder.
- Power consumption supply module : 400 mA (S2-S9), 600 mA (S12-S35), plus 200 mA respectively with optional encoder.

4.4.1.4 Parallelbus (Terminal X30)

- Connect the parallel bus cable (26-pin flat cable, protrudes from the top of the axis regulation controllers).
- The complete exchange of data between the supply module and the accessory axis regulation controllers takes place via the internal system bus on terminal X30. The connector is a component part of every axis regulation controller, the free end is connected to the respective supply module or axis regulation controller placed to the right. (Please take care that these plugs fit properly).
- Plug the terminator into the axis regulation controller furthest from the supply module (the only parallel bus connection still free).

- The continuity of the internal system bus connection from the power supply to the last axis regulation controller is monitored by the terminator. It is included in the delivery package of the supply module and is plugged into the last of the maximum of 8 axis regulation controllers (X30) of one unit. If it is missing the axes can be blocked and an appropriate error message is sent (ready-for-operation contact of power supply opens).

4.4.1.5 Control in- and outputs (Terminal X6)

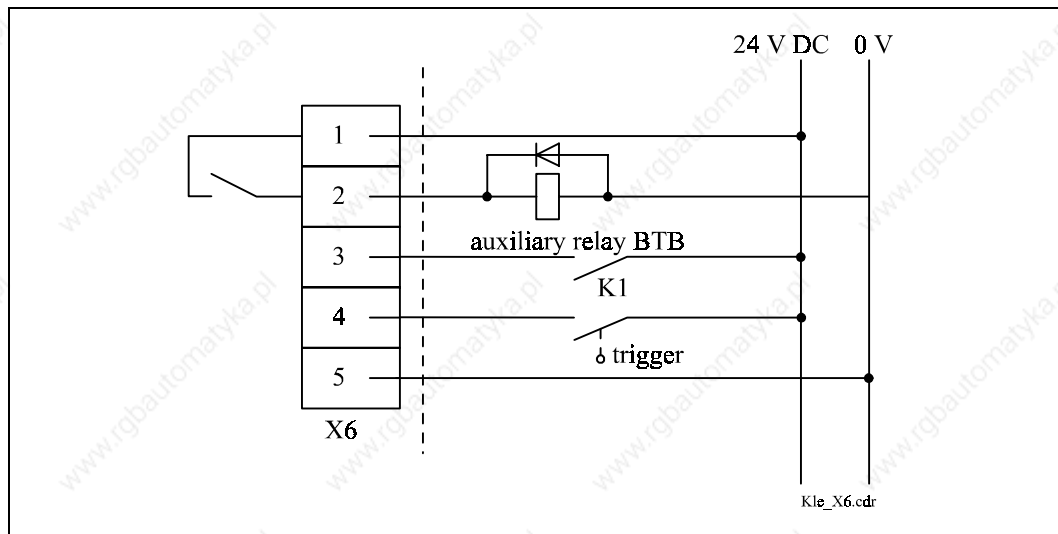

Fig. 34: Control in- and outputs

- The terminal strip X6 is in plug-in version.
- Contact X6.1/X6.2: "ready for operation"(BTB), potential-free relay contact , maximal contact load 30 V DC, 1 A. The closed contact indicates that the supply module and all axis regulation controllers connected to it are ready for operation. A relay connected on the load side to terminal 2 functions as a contact multiplication and/or to increase the contact rating of the relay contact within the supply module (X6.1+X6.2). The green display LED BTB on the supply module shows the status of the contact X6.2.
- Contact X6.3: external enabling signal, 24 V DC, opto-isolated, when this signal is switched off all axes connected to this supply module are braked for 200 ms with max. torque (speed nominal value = 0). After the 200 ms the drives are torque-free and the brake contact (axis regulation controller terminal X1.7+X1.8) opens (the brake engages). The enable signal allows the possibility of blocking all drives, independently of the user software. One must decide in isolated cases whether it is advantageous to halt the drives abruptly in a power failure, for example, or to let them run down. The enabling link must be chosen accordingly (compare Chapter 4.5).

- Contact X6.4: trigger signal 24 V DC, opto-isolated; the signal evaluation is dependent on the respective fittings of the supply module. The static status (input level) is stored in the supply module independent of fittings. If the supply module is additionally fitted with an interpolation computer module and a master encoder interface, the current encoder value can be logged for an edge change (quick logging and transfer of a current position). One current encoder value each for the rising and the falling edge can be taken over (sampling time 1.6 ms).
- Contact X6.5: 0 V external (earth); reference point for external control signals which are connected to this bar.

4.4.1.6 Absolute value and incremental position encoder interface (Terminal X8)

SAE absolute value encoder interface :

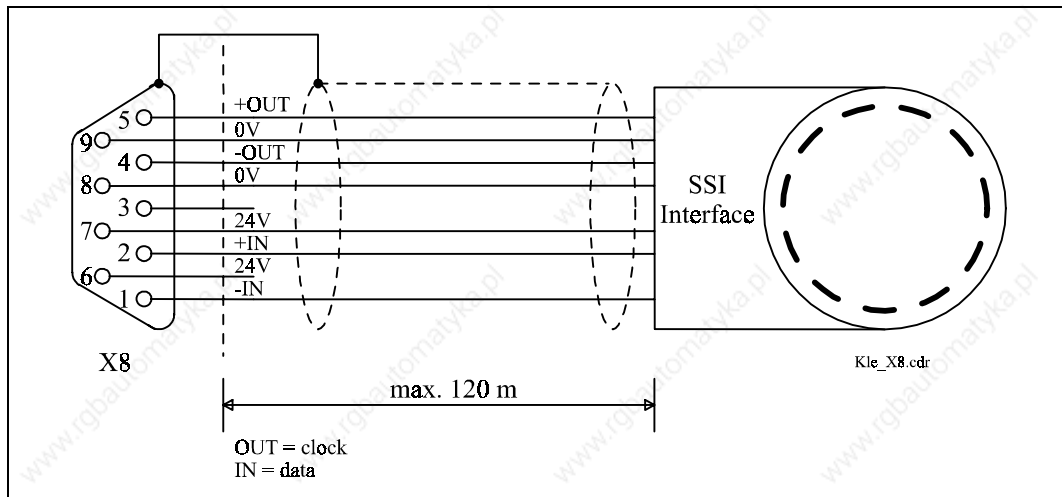

Fig. 35: SAE-absolute position encoder interface

The IN and OUT leads are designed as differential signals.

Notice

Warning: There is a discrepancy between the markings of the ferrocontrol clock leads and those of other companies: out+ corresponds to clock- and out- to clock+.

The SSI interface (Terminal X8) is an optional fitting of the DARC system . When installing the 2nd encoder please make sure that the correct option card (type key) is fitted for the encoder used.

The power supply (24 V) and the clocking (OUT) of the encoder is directly via the interface. The maximum current carrying capacity of the interface is: 300 mA. This additional current must be taken into account in the design of the 24 V power supply. The SSI interface takes over the data from the encoder via the IN leads.

In order to minimize transmission errors, the data are read from the SSI interface at the encoder twice in sequence with 2 x 25 clocks (multi-turn) or 2 x 13 clocks (single turn).

When multi-turn encoders are used the number of revolutions (maximum 4096) is transmitted with the first 12 clocks. Thus, for example, four high-order zeros are transmitted in the case of encoders with 256 revolutions. For clock 13 to 25 the increments per revolution (maximum 8192) are transmitted, whereby for encoders with fewer than 8192 increments the telegram is filled up with zeros up to the 25th clock.

When using single turn encoders only 13 clocks are necessary for transmission (maximum 8192 increments), whereby for encoders with fewer than 8192 increments the telegram is filled up with zeros up to the 13th clock.

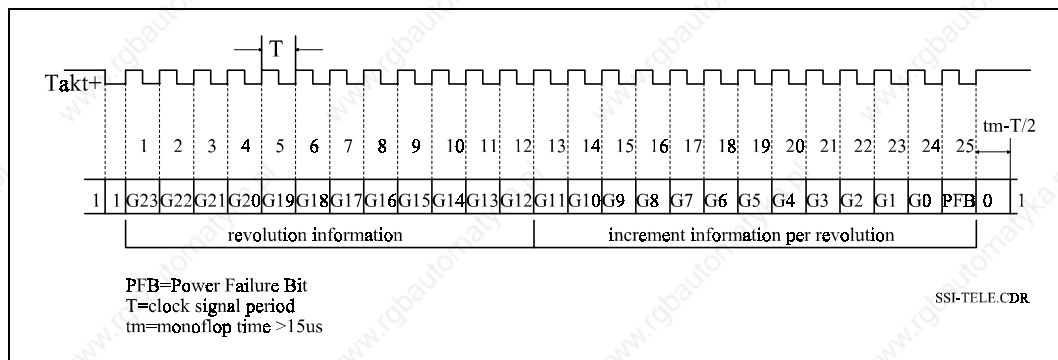

Fig. 36: Telegram of the SSI interface for multi-turn encoders

If the clock (OUT) is not interrupted for $t_m - T/2$ but output for a further 25 periods, the same data value is clocked again from the shift register. This is used for error recognition in the evaluation.

Some encoders have a power failure bit: breakdowns in the power supply voltage which are longer than 100 μ s and smaller than 5 V can lead to a corruption of the encoder information. The power failure bit (PFB) marks this error: the PFB is set to logical 1 in the serial information via a voltage comparator. For encoders that don't have this evaluation the bit must always be logical 0. The power failure bit is bit 25 of the transmission.

	max. period T_{max}	min. period T_{min}	Baud rate
SSI interface	10 μ s	5 μ s	~ 100 - 200 kbits/s

Table 21: SSI interface; Period length of the clock signal

You can find further information about available encoders in Chapter 3.6.2.2

Incremental position encoder interface:

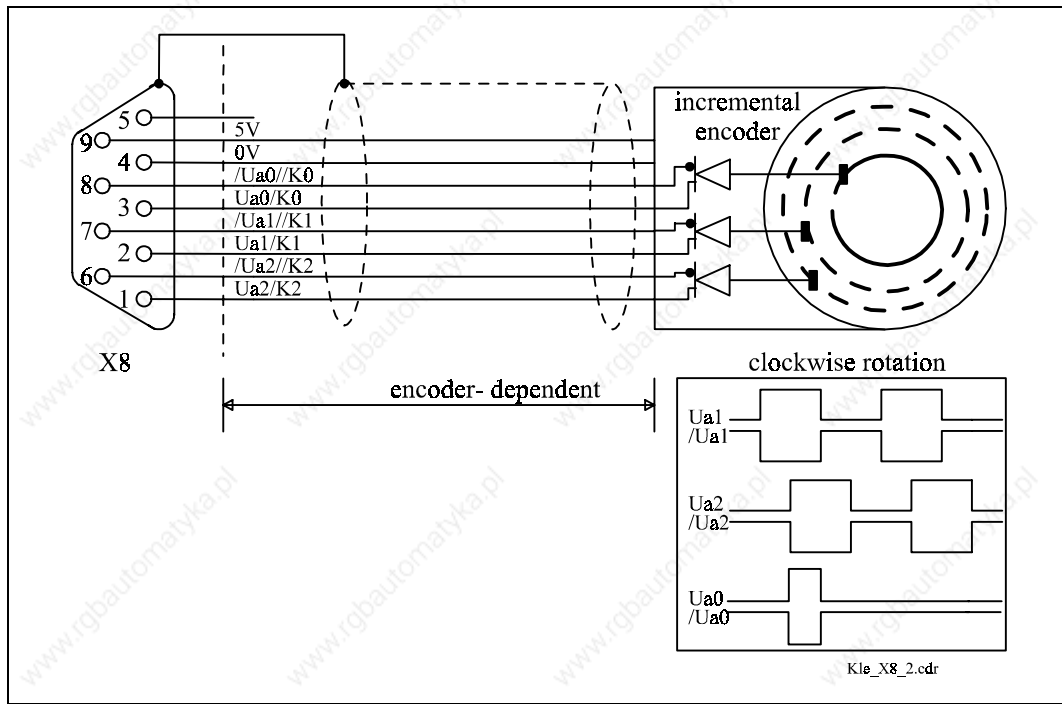

Fig. 37: Incremental position encoder interface

As an alternative to the SAE encoder an incremental position encoder can be used. When installing the 2nd encoder please make sure that the correct option card (type key) is fitted for the encoder used.

Power (5 V) is supplied to the encoder directly via the interface. The maximum current carrying capacity of the interface is: 300 mA.

Incremental position encoders can be connected with two 5 V complementary outputs (differential leads) electrically staggered by 90°. The index pulse can be connected. The input frequency of the pulses is set at $f \leq 160$ kHz. If the INC distributor is used, the connection at terminal X8 is identical.

You can find further information about the available encoders in Chapter 3.6.2.1.

4.4.1.7 Measuring points (Terminal X9)



Stop

The connections of terminal X9 are routed directly to the microprocessor! The system can be destroyed by incorrect connections! This interface may only be used by ferrocontrol.

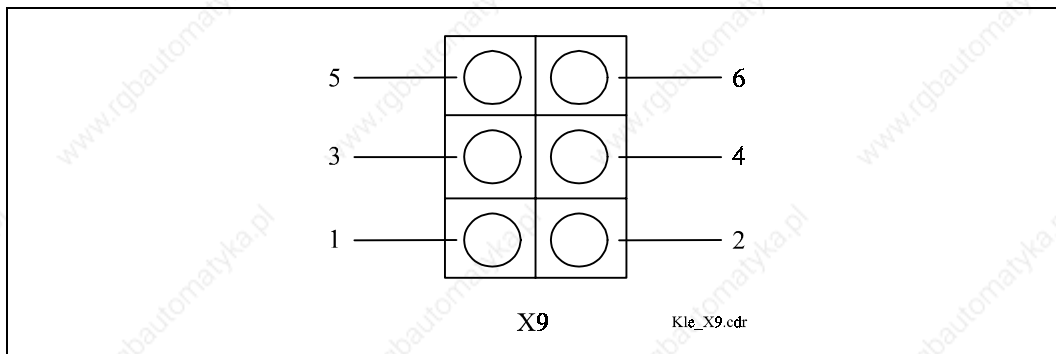

Fig. 38: Measuring points supply module

Pin number	Pin description	Level
1	not to be used	-
2	Channel A	0 - 5V
3	not to be used	-
4	Channel B	0 - 5V
5	connected via 15 kΩ with GND	0 V
6	connected via 15 kΩ with GND	0 V

Table 22: Measuring points supply module

4.4.1.8 Service interface RS-232 / Override potentiometer connection (Terminal X7)

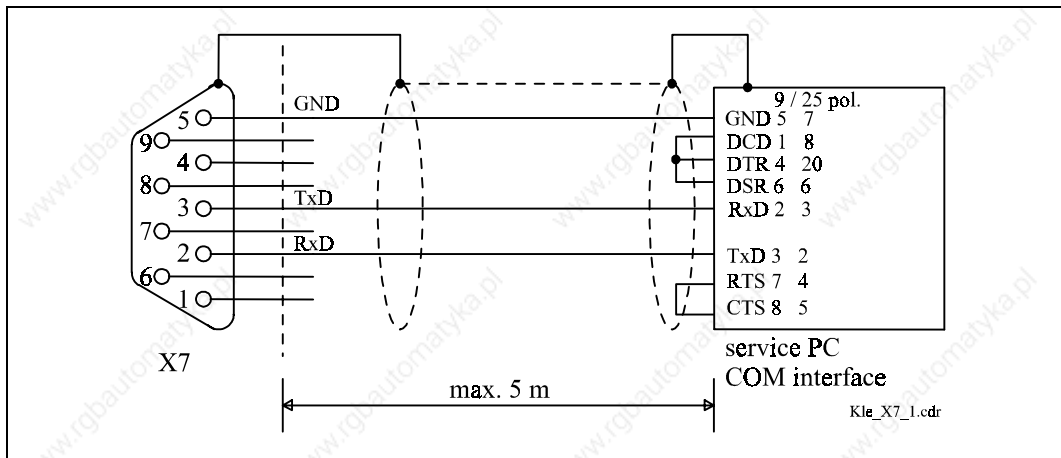

Fig. 39: Service interface RS-232

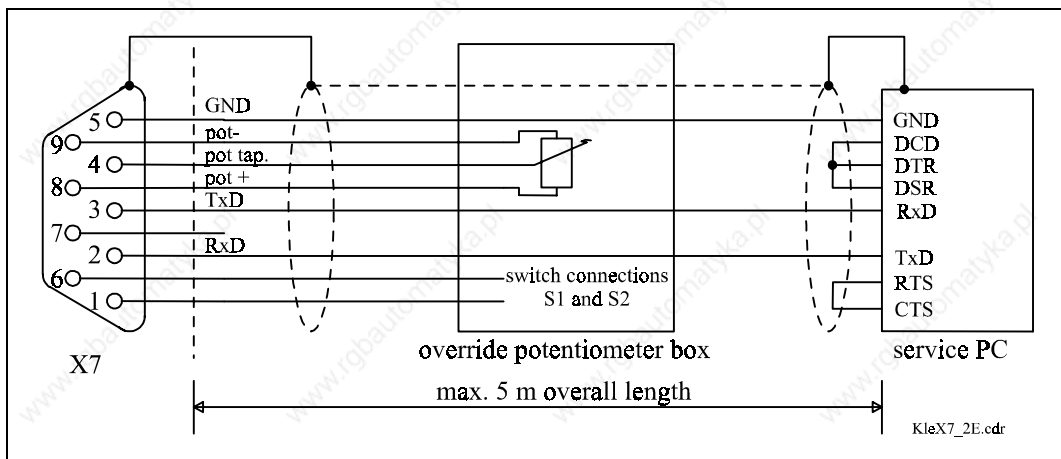

Fig. 40: Service interface with override potentiometer connection

- This plug functions as the RS 232 connection or as the connection plug for the override potentiometer (pin 8 and 9 with 10 kΩ, sliding contact at pin 4).
- Connect either the service interface cable or the override potentiometer cable.
- With cable lengths $l > 5$ m an isolation amplifier must be used for the override potentiometer.
- Should an override potentiometer be used for axis regulation controllers at different supply modules, a multiple potentiometer must be used (special application, standard cable can no longer be used).
- Make sure that the override potentiometer external connection is not potentially isolated.

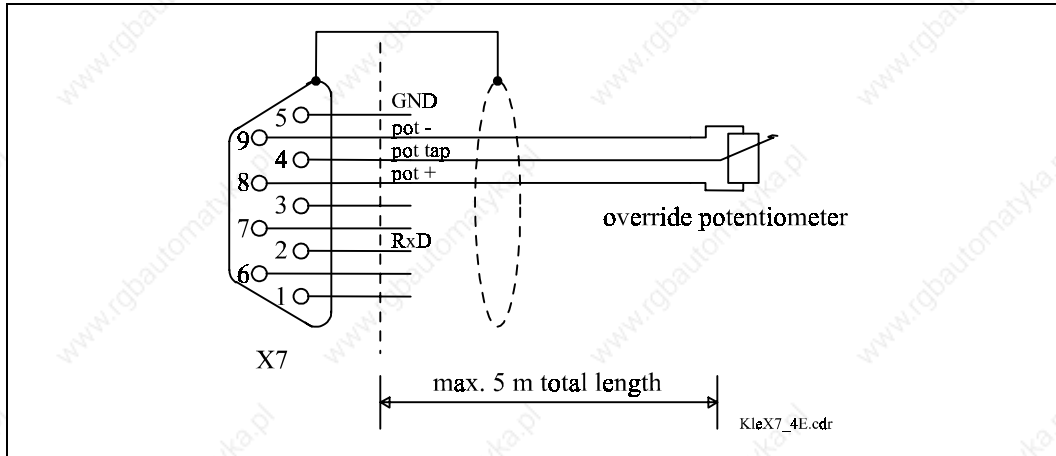

Fig. 41: Override potentiometer connection

If the override potentiometer is to be used on its own, only the connections pin 4, 8 and 9 may be used.

Notice

If the override potentiometer is not used (not plugged in), the parameter for activating the override potentiometer value must also be reset! (See also the documentation "DARC System Programming", Doc. no.97-052600)

If the override potentiometer is activated but not plugged in, the possible profile velocity of the axes, conditional on the internal wiring, is only about 80% of the maximum profile velocity.

In case of default the override potentiometer is **not** active!

4.4.1.9 Profibus-DP-Bus connection (terminal X10)

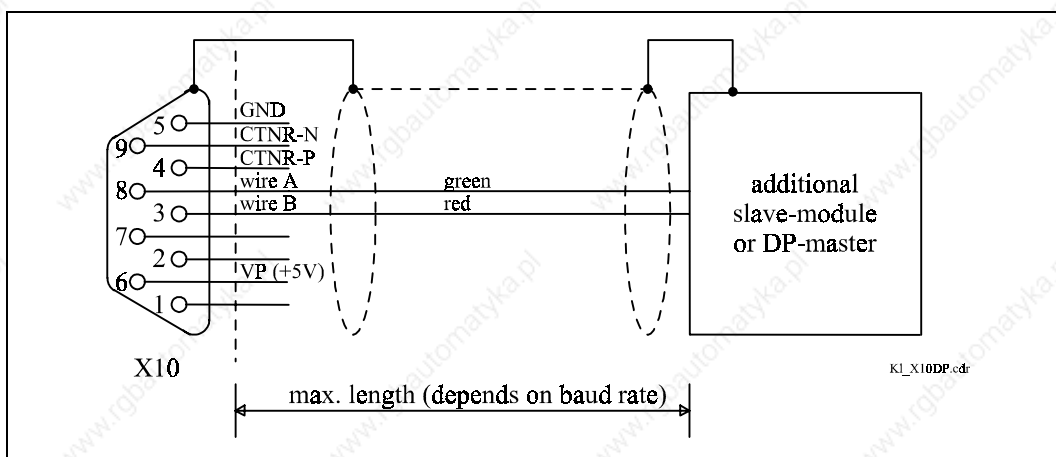

Fig. 42: Profibus-DP - fieldbus connection)

- Connect the Profibus DP fieldbus cable. This connection is for the data exchange between the supply module and the overriding control centre (industrial PC with SPS, Simatic S7 controller, etc.). You will find information about the maximum cable length further on in this chapter.
- The DARC system is connected to the Profibus network by a 9-pin SUD-D plug as specified in EN 50170 Part 3.
- The contacts PIN 6 (VP) and 5 (GND) provide the power supply voltage for the terminators in the plug. The maximum current carrying capacity is $I_{\max} = 100\text{mA}$.
- The data communication is carried out via the contacts PIN 3 and 8; the RS-485 signals A and B must be contacted in the same way for all Profibus participants, otherwise there can be no communication via the bus medium. The Profibus interface of the DARC system supplies a TTL control signal for a repeater via PIN 4 (CTNR-P); PIN 9 is the reference point (CTNR-N connected to GND device-internally).

Pin number	Signal	Meaning	RS-485 ref.
1	-	not occupied	
2	-	not occupied	
3	RxD/TxD-P	Receive/transmit data-P	B/B'
4	CTNR-P	Repeater control signal (TTL)	
5	GND	Data reference potential	C/C'
6	VP	Supply voltage (+5V)	
7	-	not occupied	
8	RxD/TxD-N	Receive/transmit data-P	A/A'
9	CTNR-N (GND)	Data reference potential	
Plug casing	PE	Screen of twisted two-wire leads	

Table 23: Pin configuration of the Profibus-DP interface

For every participant (slave) connected to the Profibus, the station address must be set, by which the devices in operation can be addressed by the master. Set these at DIP switch 1 on the front panel of the DARC system with a screwdriver. The device must be off circuit to do this. The switch position ON corresponds to logical 1, OFF to logical zero. The address can be set, hexadecimally coded, from 1 to 125. DIP switch S1.8 is not used.

This address must match the one set for the DP-slave in the Profibus-DP master (e.g. projecting with the hardware configurator in the Simatic 7).

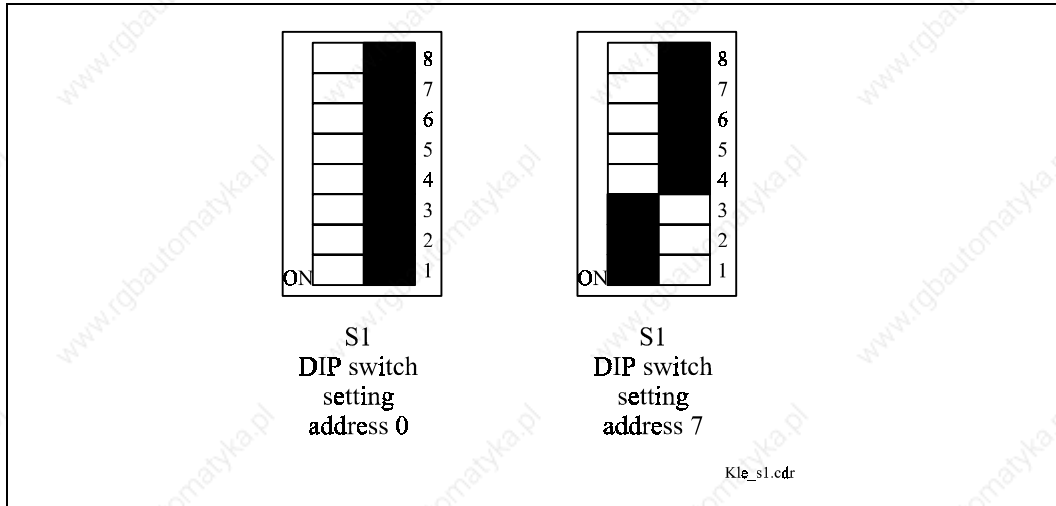

Fig. 43: Module addressing Profibus-DP

Notice

Please make sure that all participants in a Profibus-DP network are set to different addresses!

4.4.1.10 Profibus-DP interface baud rate

The baud rate set by the master, at which the DARC system on the Profibus-DP is driven, is automatically recognized by the DP interface.

The following baud rates are supported by the Profibus-DP interface and recognized automatically:

Baud rate in kBit/s	9.6	19.2	93.75	187.5	500	1500	3000	6000	12000
is supported	x	x	x	x	x	x	x	x	x

Table 24: Profibus-DP baud rates supported by the DARC system

4.4.1.11 Profibus-DP wiring

When the Profibus-DP system is being wired, the cables and plugs listed in Chapters 3.6.1.12 and 3.6.1.13 are to be used.

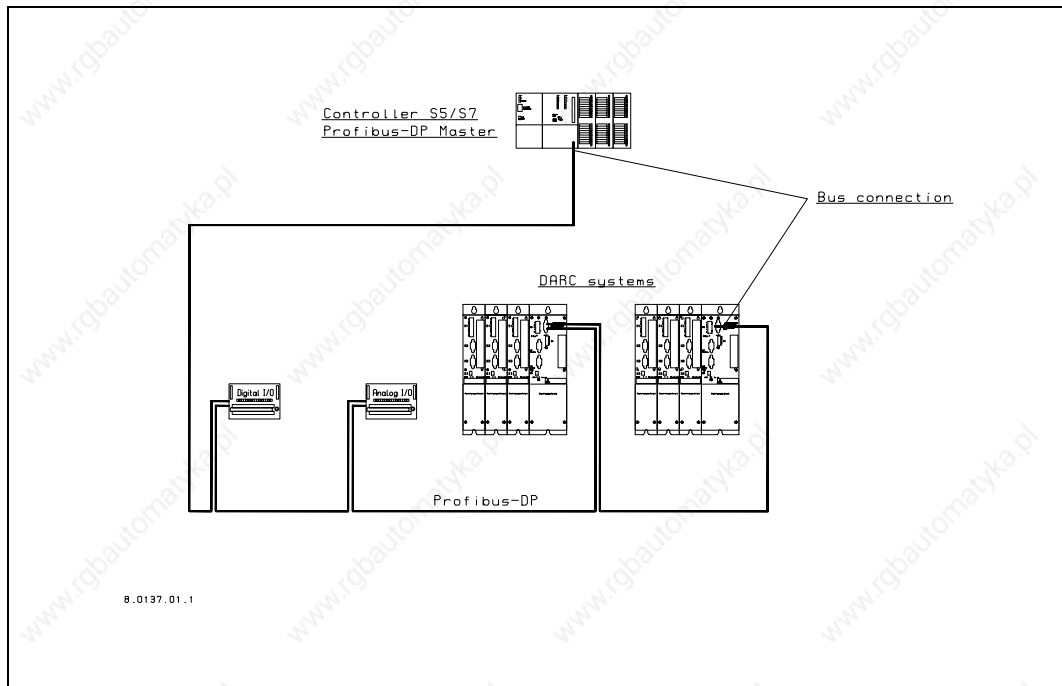

Fig. 44: Profibus-DP wiring

- A chain-like cable structure must be maintained during wiring.
- This means that if a failure occurs in one participant the other participants are not affected. If a slave breaks down, this is recognized and displayed by the Profibus master in the next cycle.
- If the DARC system is the first or the last component in the fieldbus phase, the connection to the Profibus network is not usually made via a T bus connection with an incoming and outgoing line, but with only **one** Profibus cable.
- At the physically first and last Profibus-DP participant, plugs with switched bus terminators are to be used
- These bus terminators are integrated into the Profibus plugs to be used or must be switched to "ON".

Notice:

In order to avoid malfunctions of the bus system caused by reflections etc., the Profibus segment at the physically first and last participant must be terminated with the bus terminators.

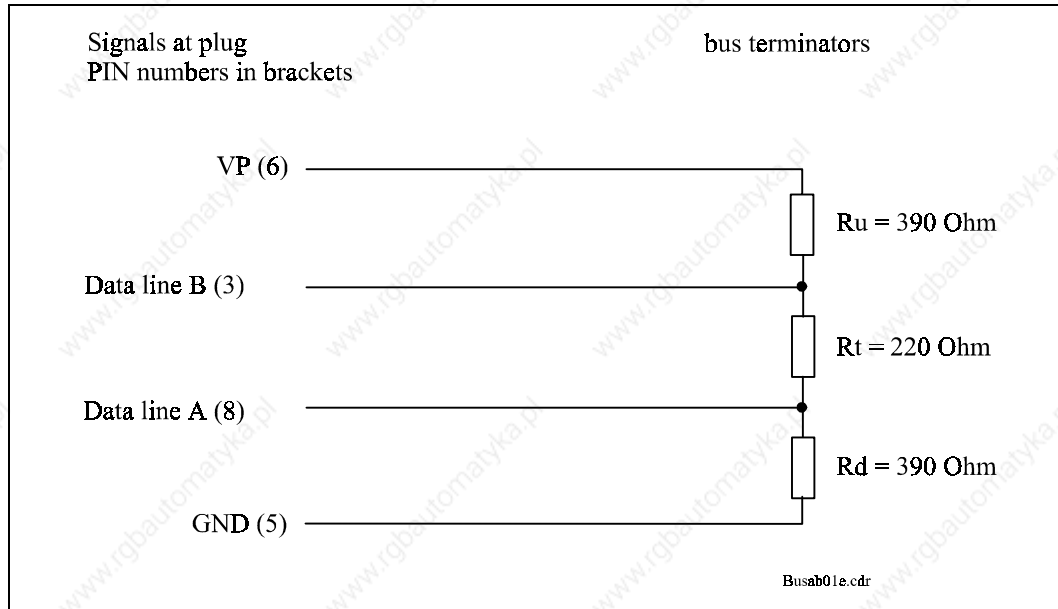

Fig. 45: Bus terminators

The Profibus-DP interface of the DARC system supports the RS-485 transmission technology and requires the cable type A as a physical medium according to EN 50170 specified for the Profibus as a screened two-wire lead in twisted pairs.

The line parameters are as follows:

Parameters	Line type A
Surge impedance in Ω	135....165
Capacitance per unit length (pF/m)	< 30
Loop resistance (Ω /km)	110
Strand diameter (mm)	0,64
Strand cross section (mm ²)	> 0,34

Table 25: Profibus-DP line parameters

A correct screening and laying of the bus cable damps the electrical parasitics pl interference which can occur in industrial surroundings. In order to achieve the best possible screening qualities and perfect data transfer, the following measures must be taken:

- Only use the prescribed plugs and the Profibus-DP line type A
- Connect the screening in the plug over a wide area
- Connect the bus cable screening at both ends
- Ensure that the bus cable is correctly terminated (bus terminator)
- Do not lay the signal and bus cables parallel to the power cables (e.g. motor cable) but if possible in separate ducts
- Avoid extending bus cables via plug-in connectors
- Lay the bus cables as near as possible along existing earthed areas
- Tighten the plug tightening screws by hand so that they cannot fall off by unintentional contact or vibration.



Stop

If fluctuations in the earth potential occur, a compensatory current can flow through the screen connected at both ends and attached to the earth potential (PE). In this case ensure that there is sufficient equipotential bonding according to the relevant VDE regulations. You can find further information in "Aufbaurichtlinien Profibus-DP/FMS" .

The line parameters specified in EN 50170 for line type A provide the following length extensions of a bus segment:

Baud rate in kBit/s	9.6, 19.2, 93.75	187.5	500	1500	3000, 6000, 12000
Line type A (length in m)	1200	1000	400	200	100

Table 26: Profibus-DP line lengths

Spur lines up to 1500 kBit/s: $l < 6.6$ m

4.4.1.12 CAN-Bus connection (terminal X10)

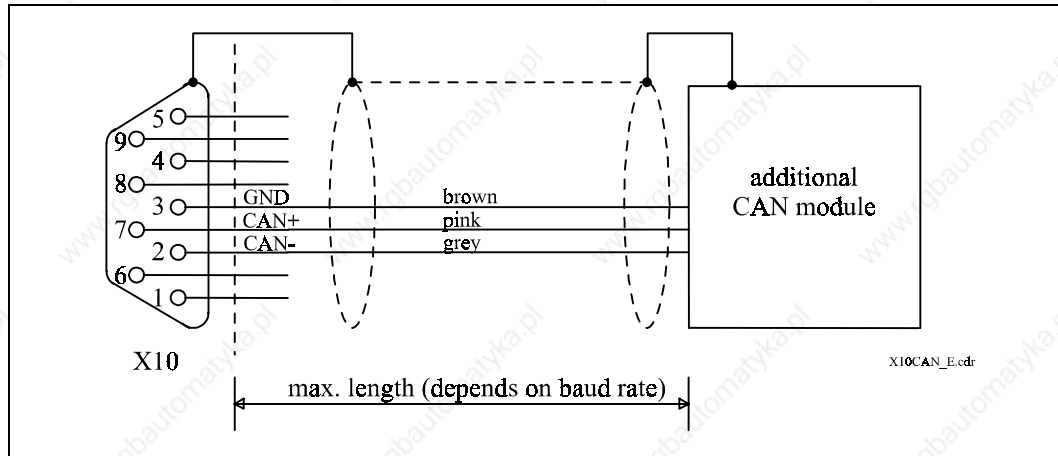

Fig. 46: CAN bus connection

- Connect the CAN bus cable. This connection is for the data exchange between the supply module and the overriding control centre (industrial PC with SPS, local controller CPU715 etc.) or other slave components. You will find information about the maximum cable length further on in this chapter.
- The DARC system is connected to the CAN bus network by a 9-pin SUD-D plug in accordance with CiA DS102.
- The data communication takes place via the contacts PIN 2 and 7; the data leads must be contacted in the same way for all CAN participants, otherwise there is no communication via the bus medium. The reference potential is PIN 3.

Pin number	Signal	Meaning
1	-	not occupied
2	CAN -	Data line - (dominant low)
3	CAN_GND	Reference potential (earth)
4	-	not occupied
5	(CAN_SHLD)	Only connect the screen here if there is no contact via the plug casing
6	(GND)	24 V power supply earth, not connected in the DARC
7	CAN +	Data line +
8	-	not occupied
9	(CAN_V+)	24 V power supply earth, not connected in the DARC
Plug casing	CAN_SHLD	Screen of the twisted two-wire leads

Table 27: Pin configuration of the CAN bus interface

For every participant (slave) connected to the CAN bus, the station address must be set, by which the devices in operation can be addressed by the master. Set these at DIP switch 1 on the front panel of the DARC system with a screwdriver. The device must be off circuit to do this. The switch position ON corresponds to logical 1, OFF to logical zero. The address can be set, hexadecimally coded, from 1 to 36. (S1.1 to S1.5 address 1-31 at S1.8 to "off" and S1.1 S1.5 address 32-63 at S1.8 to "on")

This address must match the one set for the appropriate slave (DARC system) in the CAN master (e.g. projecting with the hardware configurator).

DIP switch S1	Switch:	Function:
	1 ... 5	CAN address
	6 ... 7	Bit rate
	8	Switching address group 1 and 2

Table 28: Setting the bit rate on the SeleCan bus

Notice

Ensure that all CAN bus network participants are set to a different address!

4.4.1.13 Baud rate of the CAN bus interface

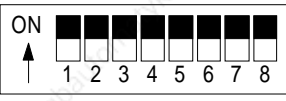
The baud rate prescribed by the master for the CAN bus network must be set in the DARC system.

The following baud rates are supported by the CAN bus interface:

DIP switch S1		
6	7	Bit rate
off	off	20 kBit/s
ON	off	100 kBit/s
off	ON	500 kBit/s
ON	ON	1 MBit/s

Table 29: CAN bus bit rate

- A uniform baud rate for a CAN network is selected during commissioning for all devices connected to the bus.
- The baud rate is set with the DIP switches 6 and 7. It must be set to the same value for all node modules.

4.4.1.14 CAN bus wiring

For wiring the CAN bus system the leads and plugs listed in Chapter 3.6.1.14 and 3.6.1.15 must be used.

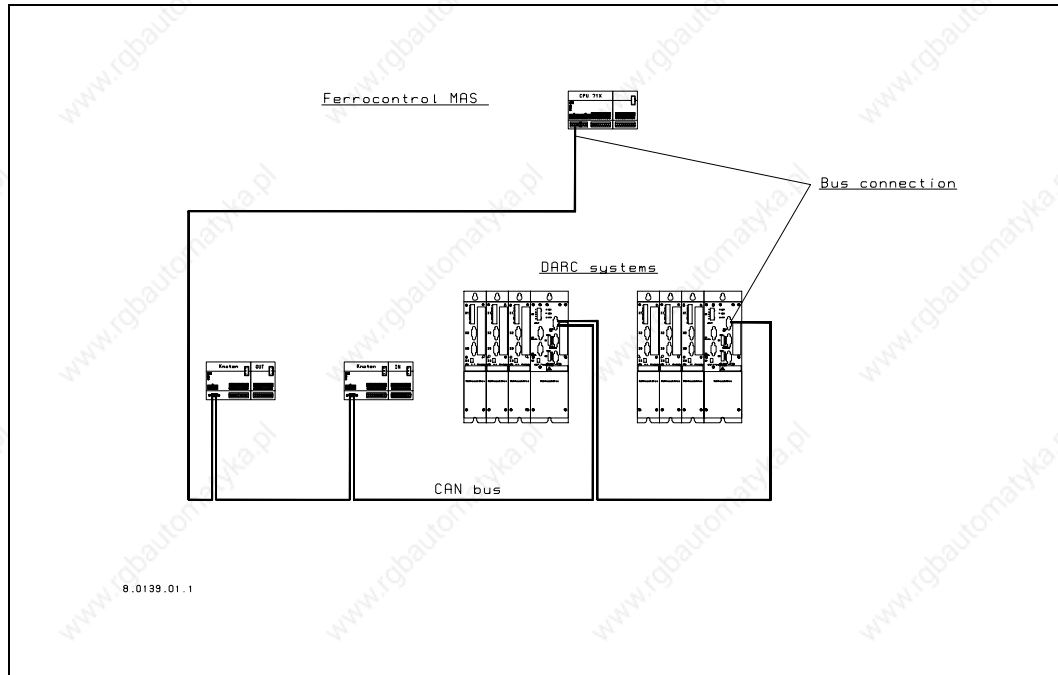

Fig. 47: CAN bus wiring

- A chain-like cable structure must be maintained during wiring.
- This means that if a failure occurs in one participant the other participants are not affected. If a slave breaks down, this is recognized and displayed by the CAN master in the next cycle.
- If the DARC system is the first or the last component in the fieldbus phase, the connection to the CAN bus network is not usually made via a T bus connection with an incoming and outgoing line, but with only **one** cable.
- At the physically first and last CAN bus participant plugs with switched bus terminators are to be used
- These bus terminators are integrated into the Profibus plugs to be used or must be switched to "ON".

Notice:

In order to avoid malfunctions of the bus system caused by reflections etc., the CAN bus segment at the physically first and last participant must be terminated with the bus terminators.



Fig. 48: CAN bus terminators

The CAN bus interface of the DARC system supports the RS485 transmission technology and requires the CAN bus cable according to ISO11898:

Parameters	Notation	Unit	Val.			Conditions
			min.	nom.	max.	
Impedance	Z	Ω	108	120	132	Measured between two data lines
Conductor resistance	R	Ω/km		38.9		
Strand diameter	d	mm		0.80		
Strand cross section	A	mm^2		0.50		
Delay		ns/m		5		Impulse

Table 30: CAN bus line parameters

A correct screening and laying of the bus cable damps the electrical parasitics and interference which can occur in industrial surroundings. In order to achieve the best possible screening qualities and perfect data transfer, the following measures must be taken:

- Only use the prescribed plugs and the CAN bus cable
- Connect the screening in the plug over a wide area
- Connect the bus cable screening at both ends

- Ensure that the bus cable is correctly terminated (bus terminator)
- Do not lay the signal and bus cables parallel to the power cables (e.g. motor cable) but if possible in separate ducts
- Avoid extending bus cables via plug-in connectors
- Lay the bus cables as near as possible along existing earthed areas
- Tighten the plug tightening screws by hand so that they cannot fall off by unintentional contact or vibration.



Stop

If fluctuations in the earth potential occur, a compensatory current can flow through the screen connected at both ends and attached to the earth potential (PE). In this case ensure that there is sufficient equipotential bonding according to the relevant VDE regulations.

The line parameters specified in EN 50170 for line type A provide the following length extensions of a bus segment:

Baud rate in kBit/s	20	100	500	1000
Length in m	cable-dependent	cable-dependent	100	40
max. spur line lengths in m	7.5	3.75	0.75	0.3

Table 31: CAN bus cable lengths

Notice

The maximum cable lengths is not only determined by the baud rate, but for lengths longer than 300m the conductor resistance limits the maximum possible length of the cable. You can find the maximum possible cable lengths for the various cable types in Chapter 3.6.1.14.

4.4.1.15 Prog/User interface (only with CAN bus interface, Terminal X12)

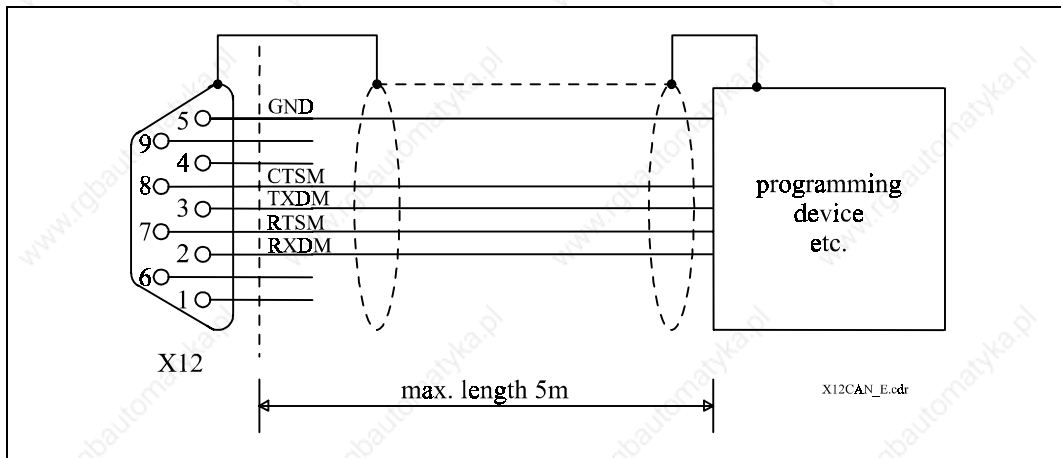

Fig. 49: Prog/User interface for CAN busconnection

The firmware of the CAN bus interface is loaded onto the DARC system via this interface. See also Chapter 6.2.

Notice

In a following version of this documentation the Prog/User interface (Terminal X12) and the DIP switch S2 will be described.

4.4.1.16 Module bus connection (only for CAN bus interface, Terminal X13)

Fig. 50: Module bus connection (in preparation)

Notice

In one of the following versions of this documentation the module bus connection (terminal X13) will be described.

4.4.2 Axis regulation controller

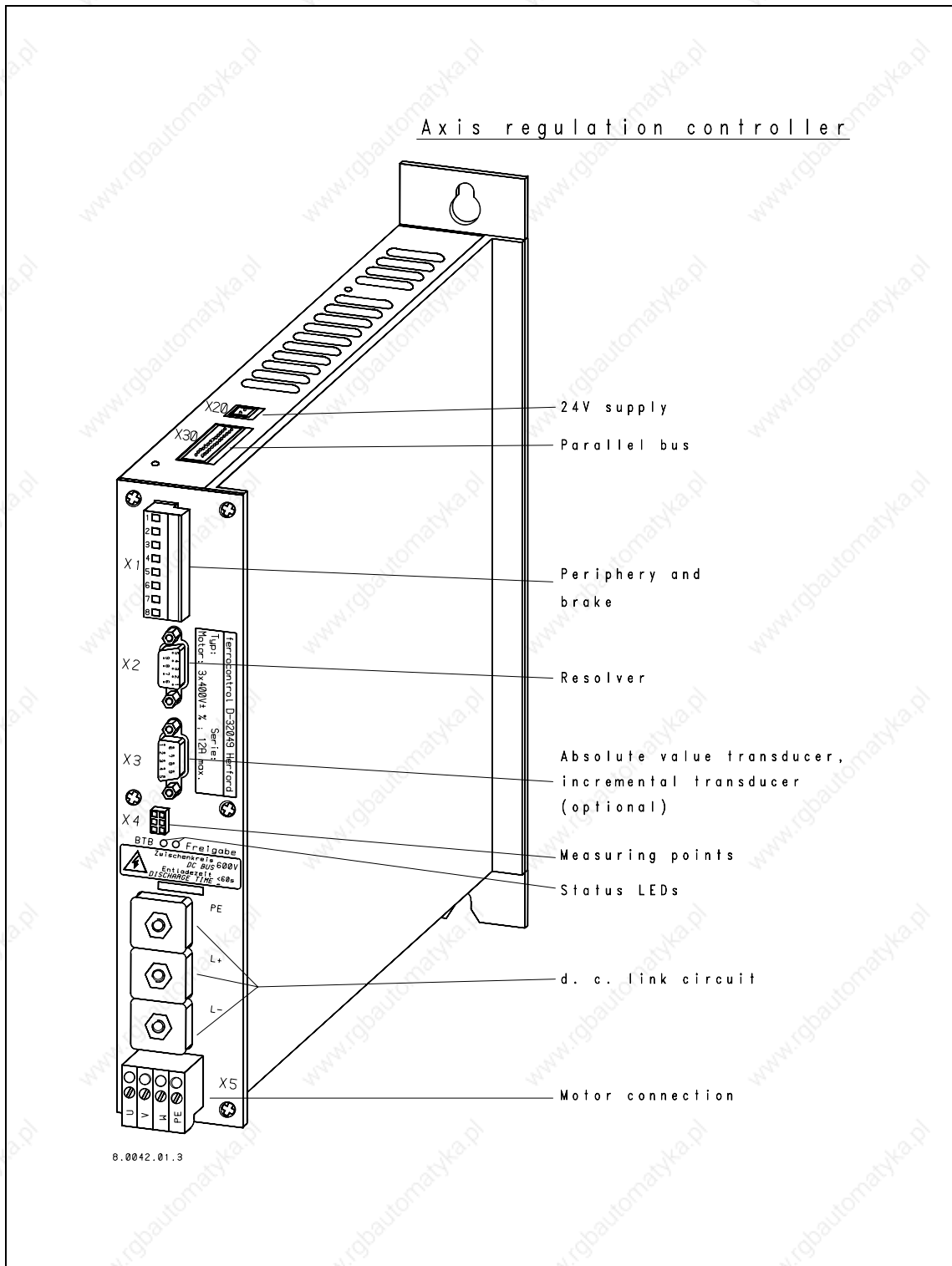

Fig. 51: Axis regulation controller connections

4.4.2.1 Motor cable connection (Terminal X5)

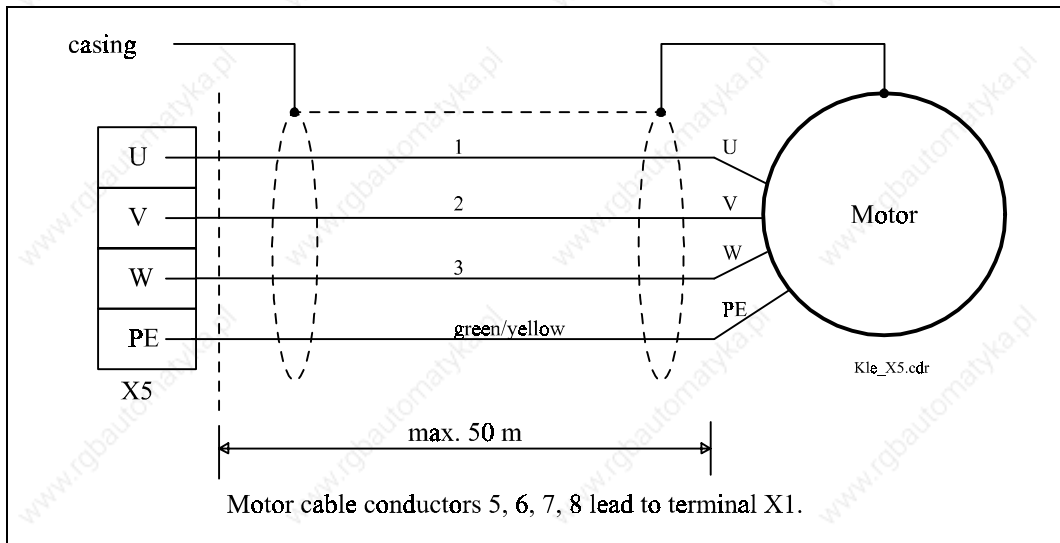

Fig. 52: Motor cable connection

- Select the prescribed cross section of the motor cable.
- Connect the motor cable to the screw terminals U, V, W, PE. All axis regulation controllers must be earthed on a common star point with a conductor cross section of at least 6 mm².
- Connect the screen to the screen connection and to the motor (e.g. EMC screw connection).

Axis regulation controller	S2	S4	S6	S9	S12	S18	S25	S35
Motor lead [mm ²]	0.75-1.5	1.5	1.5	2.5	2.5	6	6	6
Equipment terminal cross section [mm ²]	2.5	2.5	2.5	2.5	6	6	6	6

Table 32: Connections axis regulation controller

4.4.2.2 D.c. link (terminal L+, L-, PE)

The contents of this chapter are identical to Chapter 4.4.1.2.

4.4.2.3 24 V power supply (Terminal X20)

The contents of this chapter are identical to Chapter 4.4.1.3.

4.4.2.4 Parallelbus (Terminal X30)

The contents of this chapter are identical to Chapter 4.4.1.4.

4.4.2.5 Peripheral equipment and holding brake (Terminal X1)

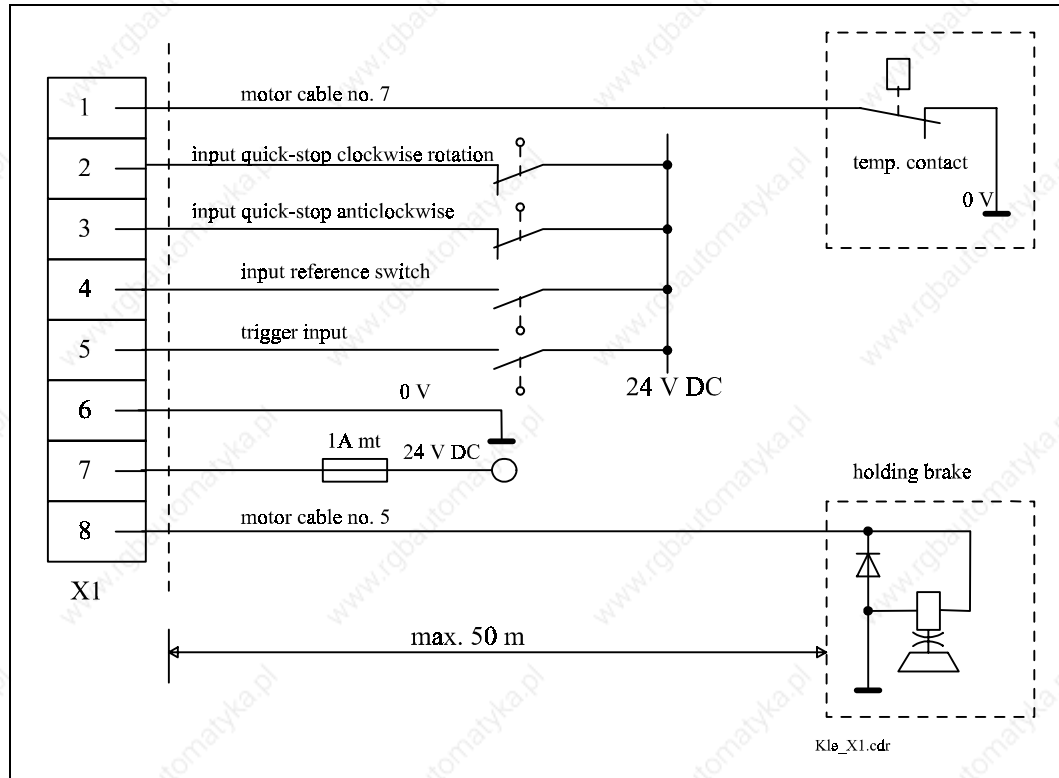

Fig. 53: Peripheral equipment and holding brake

- The terminal strip X1 can be found on the face of every axis regulation controllers and is available as a plug-in terminal. The supply voltage (24 V DC) for the terminal strip X1 must be present at the latest with the 24 V DC power supply at X20. The same power supply as at X20 can be used. All inputs must be opto-isolated.
- Contact X1.1: Input temperature monitoring of the motor. Operating point: 2.5 V (i.e. 140°C cut-out temperature). A thermal contact integrated in the motor winding or a thermal sensor (PTC resistance/thermistor) can be evaluated from the respective axis regulation controller.
- Contact X1.2: Input quick-stop clockwise (no safety stop because evaluated in software). The input must be switched via an external transducer (switch, initiator, proximity switch or bridge) with 24 V DC. If the input is open this prevents the motor from running clockwise, i.e. it causes braking at the quick-stop ramp (not at the current limit).

- Contact X1.3: Input quick-stop anti-clockwise clockwise (no safety stop because evaluated in software). The input must be switched via an external transducer (switch, initiator, proximity switch or bridge) with 24 V DC. If the input is open this prevents the motor from running anti-clockwise, i.e. it causes braking at the quick-stop ramp (not at the current limit).
- **Comment on contacts X1.2 and X1.3:** When a switch is approached it causes the quick-stop reaction set in the service to be carried out. The motor remains afterwards in the position it has reached in standstill control (position control), until a drive order in the other direction is given or the input is available again. The error message is immediately sent to the computer.
- Contact X1.4: Reference input 24 V for referencing the axes. This is not the absolute zero position! When it is first activated the axis is referenced to the current resolver value, the actual value zero is assigned to this position.
- Contact X1.5: Trigger signal 24 V DC (quick measuring input). This input functions as a quick logging and transfer of a current position e.g. when scanning a part. Positional values are taken over for rising and falling edges, the scanning time is 200 μ s for position control via the resolver; for position control via the 2nd encoder the scanning time is 3.2 ms. the static input level is also stored in the axis regulation controller and is transferred on to the supply module.
- Contact X1.6: 0 V connected externally to earth. Reference point for external control signals.
- Contact X1.7 / X1.8: Holding brake, potential-free relay contact . Max. contact load : 30 V DC 1 A.
- Connect the servo motor temperature monitor (contact X1.1, 0 V). A thermal contact or thermal sensor (PTC thermistor) integrated in the motor winding can be evaluated from the respective axis regulation controller.
- Connect the holding brake, if it is part of the motor equipment (terminal 8, 0 V). It can be controlled directly via a potential-free contact in the respective axis regulation controller. For a contact load > 1 A a coupling relay or a contactor relay must be connected in series. The contact is coupled to the internal "regulator enabling" (operated by software in position control) and closes to release the brake. Please read further notices in Chapter 4.5.2.



Warning!

A suppressor diode must be fitted to the holding brake release coil at all costs, if necessary a medium time-lag fuse 1 A (mt) should be connected on the line side. For a motor lead cross section of the three phases of 0.75 mm² the suppressor diode must be wired in the switching cabinet, otherwise directly to the motor connection.

- Please ensure that the screening of the motor cable is properly connected.



Stop

Please ensure at all costs that the suppressor diode is correctly poled when wiring!

4.4.2.6 Resolver interface (Terminal X2)

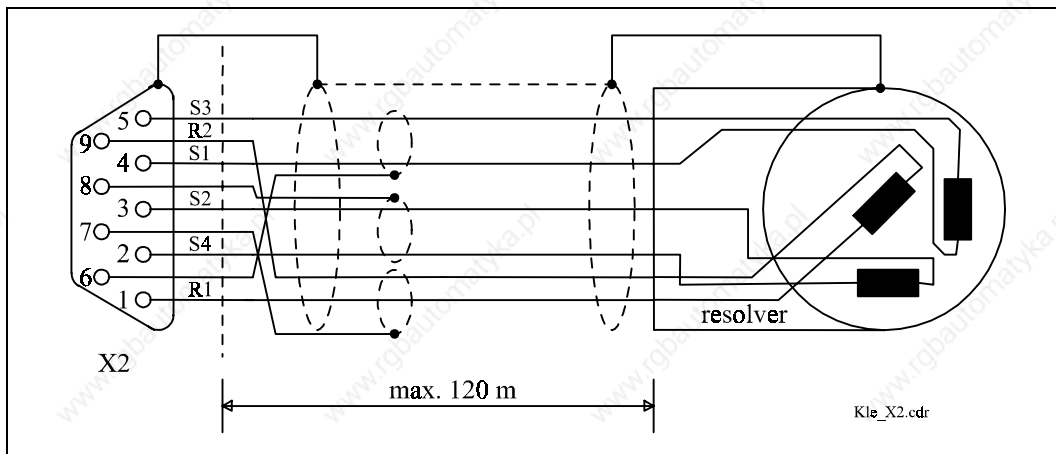

Fig. 54: Resolver interface

- The resolver interface functions as a connection for a feedback module for speed, rotor position and position logging integrated in a servo motor. The resolver socket outlet on the motor side is part of the delivery package of the motor.
- Connect the resolver cable; the resolver connection is absolutely necessary as it is used to carry out the speed measurement.

- The resolution in a resolver encoder system does not mean position accuracy. The accuracy of the standard resolvers today is stated as approx. 2^{11} flexible increments. The most commonly used resolver/digital converters realise accuracy according to type of approx. 2^{10} to 2^{13} increments per revolution. The basic DARC model achieves a positioning accuracy of 10 bits resolution per revolution with reference to the motor shaft.
- The system operates partially absolutely, i.e. the evaluation is made absolutely for one motor revolution (0-65535), then the revolutions are added together internally in the axis regulation controller.
- The referential voltage of the rotor coil is: $U_{\text{eff}} = 3.5 \text{ V}$, $f = 10 \text{ kHz}$.

Resolution	Absolute accuracy with commonly used resolvers/digital converters
16 bits at speeds < 500 rpm	10 bits
14 bits at speeds 500 - 2000 rpm	10 bits
12 bits at speeds 2000 - 6000 rpm	10 bits

Table 33: Resolver resolution/accuracy

4.4.2.7 Absolute value and incremental position encoder interface (Terminal X3)

The contents of this chapter are identical to Chapter 4.4.1.6.

4.4.2.8 Measuring points (Terminal X4)

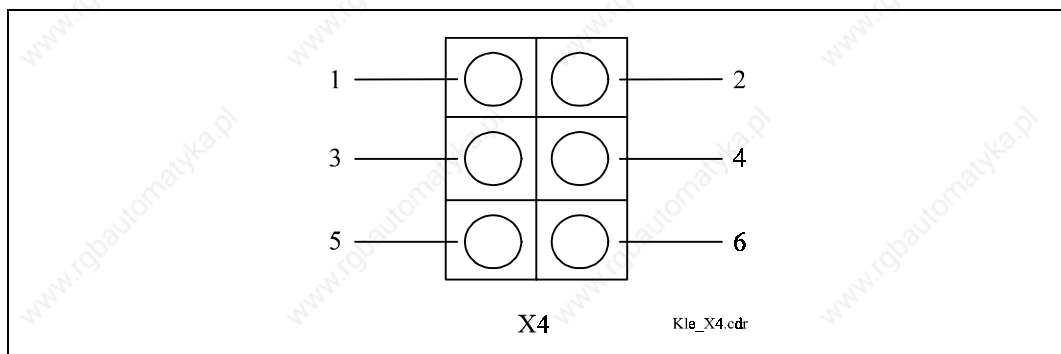

Fig. 55: Measuring points axis regulation controller

Pin number	Pin description	Level
1	Tachometer	0 V = 0 r/min, 1.2 V = 1000 r/min
2	Torque (corresponds to % of peak current)	2.5 V = 0 % 0.5 V = -100 % 4.5 V = +100 %
3	Current limiting at peak current	active = 5 V, not active = 0 V
4	Earth - reference point	0 V
5	Position reached	yes = 5 V, no = 0 V
6	Control window reached	yes = 5 V, no = 0 V

Table 34: Measuring points axis regulation controller

- The measuring socket X4 on the axis regulation controller supplies several important internal quantities directly for measuring which are useful for test purposes.
- When the machine is in operation the quantities on the axis regulation controller can be accessed directly with the oscilloscope.

4.5 Suppressor circuits

4.5.1 Emergency-OFF suppressor circuits

In an EMERGENCY-OFF SITUATION in a plant a maloperation of the servo drive must be taken into account. For this reason, the power must be disconnected at all costs. Possible danger to persons during the standstill process must be ruled out on a higher level in the plant. Electrically released brakes must be provided for vertical axes. The functional aspects for EMERGENCY OFF must be taken into account according to EN 418 or EN 60204-1.

EMERGENCY OFF must function as a stop of category 0 or of category 1. The category of the EMERGENCY OFF must be set by a risk assessment of the machine (compare EN 954-1 "Safety-related parts of controllers").

The **EMERGENCY OFF function of category 0** means shutdown by immediate switching off of the mains power supply of the supply module. Only fixed-wiring electromechanical components may be used for this purpose. The 24 V control voltage must be maintained. The release may not be dependent on switching logic (hardware or software) or on the transmission of orders via a communication network or a data circuit.

The **EMERGENCY OFF function of category 1** is a controlled system stop, whereby the energy supply to the machine servo-drives is maintained in order to

achieve the stop. The power supply is only interrupted after a time in which the standstill is reached while the plant is functioning (electrical brakes). The final switching off of the power supply to the drives must be guaranteed by using electromechanical components.

In most cases the rapid release of the kinetic energy of the axes in an EMERGENCY OFF is required.



Warning

For 1 minute after the power supply has been turned off there are still dangerous voltages in the DARC system!

When using the DARC system there are the following possibilities of bringing the drive to a standstill and of switching off the power supply:

According to **category 0** the immediate switching off of the power supply to the supply module is made via the EMERGENCY OFF circuit and simultaneously disconnection of the regulator release which causes the drives to brake for 200 ms from the recovered energy with maximum torque. This depends on the axis regulation controller being intact. When the electronics fail the drive coasts, as it does when there is a complete mains supply failure.

If an electrical brake has to be secured when there is a failure in the control electronics, the d.c. link circuit outside the supply module is short-circuited via a d.c. link short-circuit resistor (braking resistor at X11, terminal R1, R2).

It is often advisable to delay the d.c. link short-circuit by 200 ms via a time relay (KT1) and to give the DARC system, if it is operational, the opportunity of braking on the set ramp. In the case of a defect control electronic, the d.c. link short-circuit takes effect delayed by 200 ms.



Warning

The d.c. link short circuit is only intended for cases of EMERGENCY OFF and not for constant cyclical braking, as otherwise the d.c. link short-circuit resistor and the supply module would overheat and the short-circuit contactor would be worn out prematurely.

The method of regenerative braking of all drives of a supply module, where the recovered energy is converted into heat, is the one most frequently used by ferrocontrol.

If the failure of the controlled power inverter must also be taken into account in the case of certain risks, braking by means of a *motor-winding short circuit* is carried out via a delayed-release contactor after 200 ms (KT1) has elapsed.

In the case of EMERGENCY OFF when the mains power is disconnected, the 24 V power supply to the supply module and the axis regulation controllers must remain switched on, in order to be able to display the error in the diagnosis display. The complete mains disconnection is carried out using the switch.

According to **category 1** the shutdown procedure in an EMERGENCY OFF case is **not** carried out by means of an immediate disconnection from the mains but by means of operational braking on a preset ramp.

When the EMERGENCY OFF command is given a delayed-release timing relay is switched off; causing the axis regulation controller to be disconnected from the mains. Under certain conditions which are determined after a risk assessment, emergency braking can be carried out using a d.c. link short-circuit or a winding short-circuit.

Information about preventing unintentional start-up (compare Chapter 5.1.1.5):

This concerns safety measures against unintentional start-up of drives when an error occurs in the electrical control and the safe disconnection of separate working areas of a machine or plant in case persons are present in a disconnected area of plant otherwise in operation.

If drives that should be switched off and others that should continue to operate are supplied via the same supply module and hazards can occur, the axis to be switched off must be disconnected by means of a mains switch or a power contactor behind the axis regulation controller output.

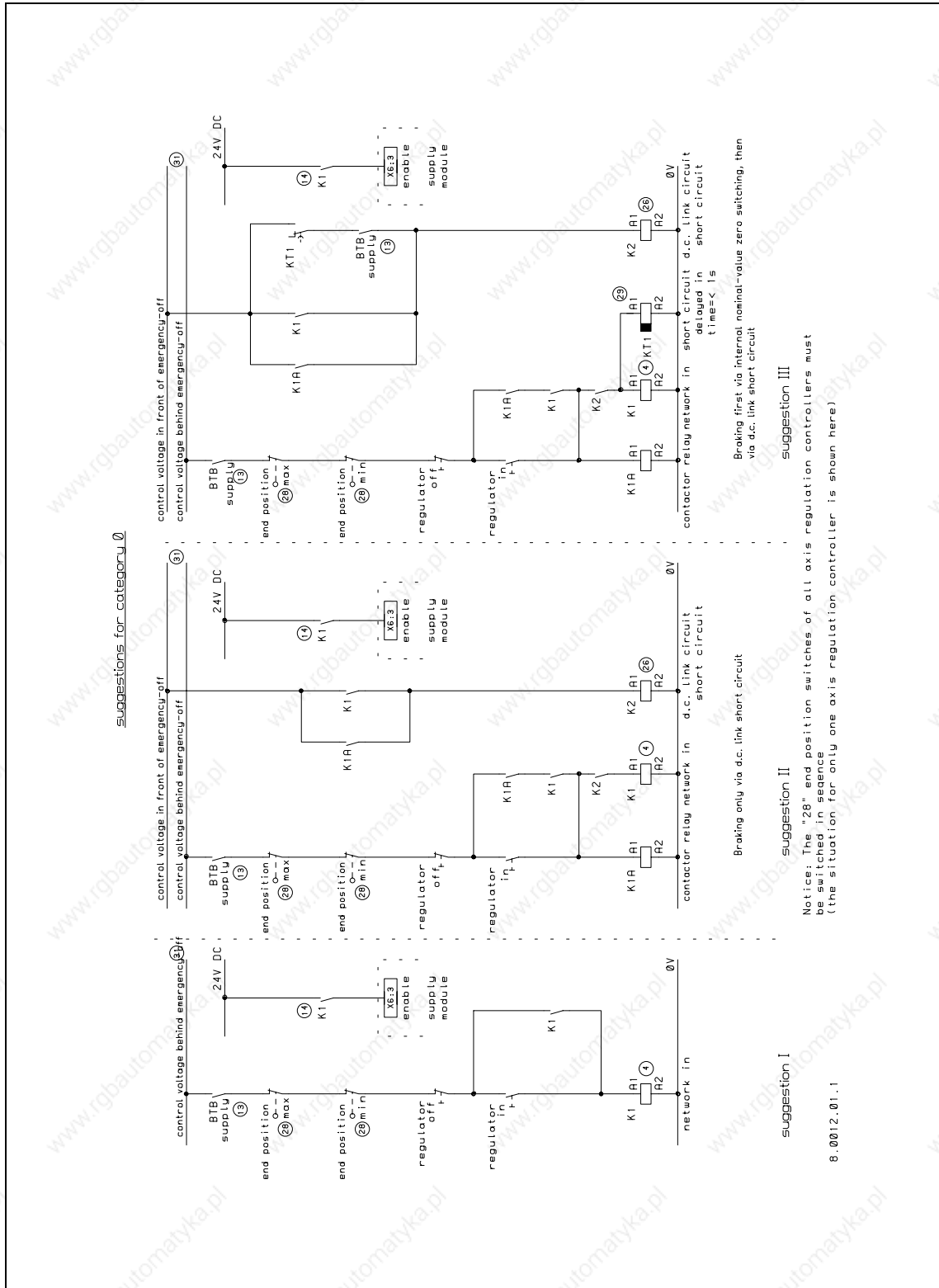

Fig. 56: Switching suggestions I-III for stopping the drives by means of hardware

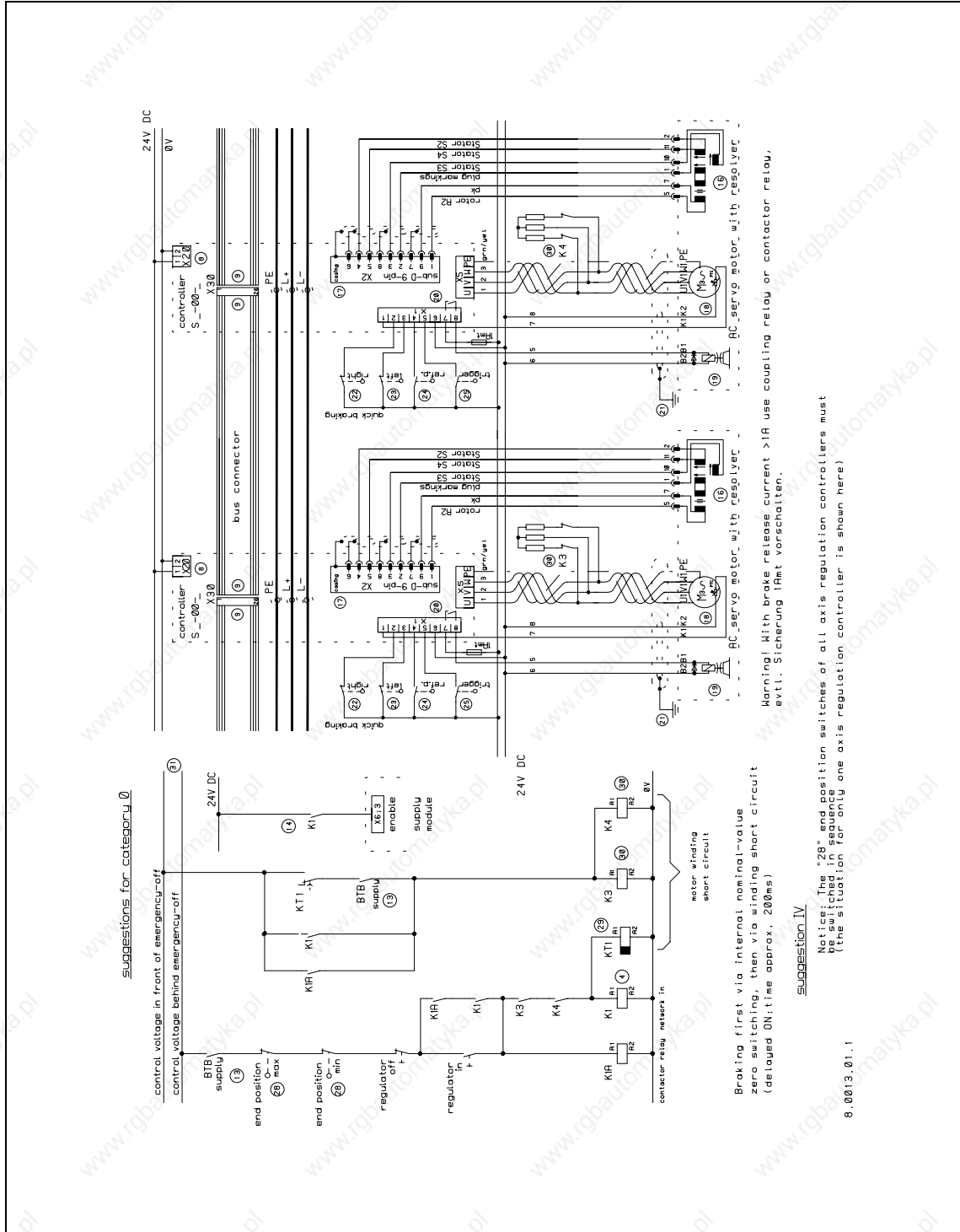

Fig. 57: Switching suggestions IV for stopping the drives by means of hardware

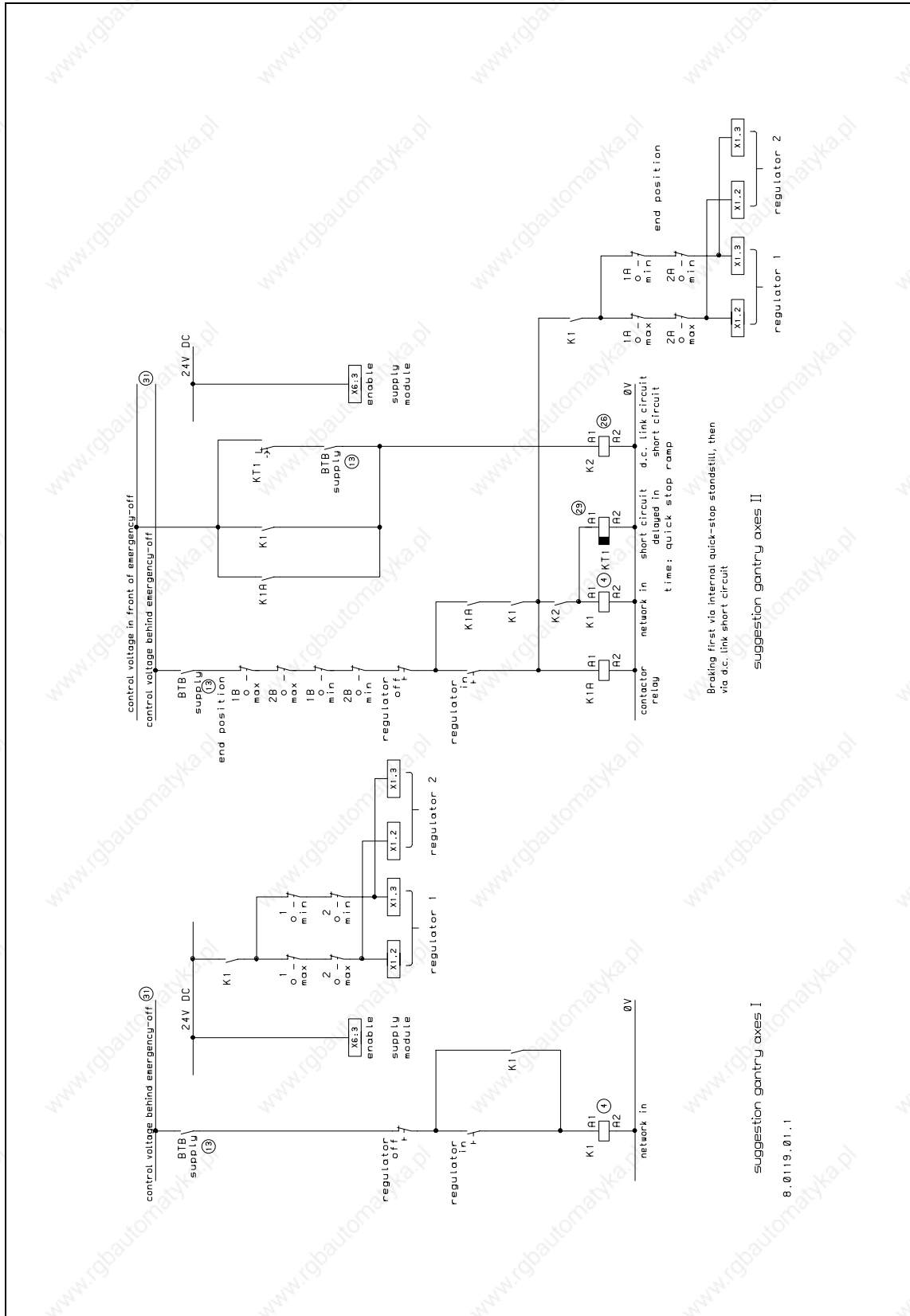

Fig. 58: Switching suggestions gantry I and gantry II for stopping the drives by means of hardware

Encircled numbers in figures "Switching suggestions for stopping the drives by means of hardware" (Fig. 56, Fig. 57, Fig. 58, further explanation can be found in Chapter 4.4).

1-25 compare Chapter 4.4.

26 D.c. link short-circuit contactor (at terminal X11)

Braking by means of a d.c. link short-circuit is a quick and commonly used method in EMERGENCY OFF situations. D.c. link short-circuit contactors and resistors are not designed for cyclical braking but only for EMERGENCY OFF situations.

The use of a d.c. link short-circuit depends on the respective application and ambient conditions. A d.c. link short-circuit contactor may only be used in connection with the accessory resistor (27). After the power supply has been released, the d.c. link short circuit causes a regenerative braking of all drives and the conversion of the recovered energy into heat.

Contactors activation must be carried out according to the logic in the switching suggestions II, III and IV.



Warning

Short-circuiting of the d.c. link circuit using the resistor is only permitted when the mains power supply is switched off. An overlap can cause the destruction of the power supply, DARC components, short-circuit contactors and resistors.

27 D.c. link short-circuit resistor (braking resistor))

The d.c. link short-circuit resistor may only be used in connection with a short-circuit contactor (26). Layout: When installing into a switching cabinet please ensure that the leads are short and twisted and that there are covers safe from finger-touch.

28 Limit switch

In nearly all applications of servo drives mechanical limiters must be provided or are prescribed for the protection of persons and machines. Limit switches must be fitted with contacts at all costs. The limit switches must be mounted in such a way that they can be approached at maximum speed without causing danger to persons or machines. The limit switch must remain active for the entire braking distance.

When **one** limit switch of **one** axis regulation controller is activated, it causes the mains contactor to be switched off and **all** drives on this supply module are braked corresponding to the suppressor circuits. In contrast, when **one** quick-stop input of

one axis regulation controller is activated, then only this **drive** is decelerated on the quick-stop ramp.

29 Slow-releasing timing relay

According to application it can be advisable to delay the activation of the d.c. link short circuit or the winding short circuit. If there is no delay in the activation of the d.c. link or the winding short circuit the residual energy in the d.c. link circuit is converted immediately into heat and is no longer available as braking energy. Because, when the DARC system is switched off, the release is maintained internally for 200 ms and an attempt is made to brake all drives at maximum torque, it is advisable to allow the winding or the d.c. link short-circuit to work for this time. This ensures a quicker standstill than with purely regenerative braking, provided the respective axis regulation controller is in order. For internal disconnecting conditions (contact X6.2, ready to run = 0) the delay should be ineffective, as shown in control suggestions III and IV.

30 Motor-winding short-circuit

In the case of particularly high safety requirements (risk assessment by the user), where the total destruction of the power inverter must be taken into account, braking must be applied via a motor winding short-circuit.

The contactor activation must be carried out according to the logic in the control suggestions III/IV. The short circuit may not be routed directly, but via appropriate short-circuit resistors. The layout of contactors and resistors depends on the performance data of the respective motor. If the resistance of the resistors is too high, the braking force is reduced considerably. If the resistance of the resistors is too low, the resultant short-circuit current causes the permanent magnets in the motor to demagnetize and thus causes a reduction in the braking force and the destruction of the motor.

In order to realise the stop category 1 an additional slow-release timing relay must be inserted in the EMERGENCY OFF circuit, causing the separation from the mains. At least the timing relay in the EMERGENCY OFF circuit must be licensed regarding its design for safety circuits (observe product information!).

31 Control voltage (24 V)

"Control voltage before EMERGENCY OFF":

It is not switched off in the case of EMERGENCY OFF or "Control voltage off".

"Control voltage behind EMERGENCY OFF":

It is switched off in the case of EMERGENCY OFF; if necessary delayed disconnection (EMERGENCY OFF category 1).

The switching suggestions described in the following for stopping the drives of DARC drive controllers using hardware, e.g. with EMERGENCY OFF or 'Move to end position' must be used

The suggestions I to IV and Gantry I and II can be used for EMERGENCY OFF category 0 and 1. The difference between category 0 and 1 is the immediate disconnection of "Control voltage behind EMERGENCY OFF" for category 0 or the delayed disconnection for category 1 and the resulting isolation of the supply modules from the mains.

The illustrated suggestions always refer to EMERGENCY OFF functions of category 0.

The suggestion Gantry axes I is only to be used if no EMERGENCY OFF category needs to be observed.

If the requests for braking at the current limit (by activating the limit switch) and for braking at the quick-stop ramp (by activating the quick-stop input) occur simultaneously, braking at the current limit always has higher priority than braking at the quick-stop ramp and is carried out in any case.

4.5.1.1 Switching suggestions for stopping the drives using hardware

Suggestion I: Braking by means of residual energy in the d.c. link circuit (compare Fig. 56).

- Axis regulation controller operational: The principal mains contactor is disconnected. When the voltage is removed from the enable input (contact K1 open) of the supply module all axis regulation controllers on this supply module receive the information to actively brake for 200 ms with maximum torque at the current limit (speed nominal value = 0) by residual energy from the d.c. link circuit (the electronics power supply for the DARC system must be maintained). After that, the drives are torque-free or they coast.
- Axis regulation controller not operational (no electronics power supply or the like): no braking effect, the drives coast.

Suggestion II: Braking via d.c. link short-circuit (compare Fig. 56).

- Immediate braking via d.c. link short-circuit. The principal mains contactor is disconnected and the d.c. link voltage is reduced via short-circuit. When the voltage is removed from the enable input (contact K1 open) of the supply module all axis regulation controllers on this supply module receive the information to actively brake for 200 ms with maximum torque at the current limit (speed nominal value = 0); however, this has no effect as the braking via the d.c. link short-circuit is superimposed onto it

- If there is a failure of a power inverter whose diodes become high-resistant, there is no braking effect.

Suggestion III: Braking for 200 ms by means of residual energy from the d.c. link circuit then d.c. link short-circuit (compare Fig. 56).

- Braking as in control suggestion I, however, after the time KT1 (29) has elapsed like Control Suggestion II. Here it must be taken into account that the braking takes place at the current limit for 200 ms according to Suggestion II, then the short-circuit in the d.c. link circuit must be induced. As a result, a relay with the disconnection delay time of 200 ms must be selected for this circuit for KT1, so that, on the one hand, the braking at the braking ramp is active for 200 ms and then braking is carried out immediately via the d.c. link short-circuit .

Suggestion IV: Braking for 200 ms by means of residual energy from the d.c. link circuit , then motor winding short circuit (compare Fig. 57).

- As in III, braking effect, however, also if the power inverter fails, with diode routes/distances that have become high-resistant, by means of motor winding short circuit instead of the d.c. link short circuit. Braking at the current limit also takes place here for approx. 200 ms after the enabling has been removed at the supply module.

Combination of Suggestions III and IV:

- For a maximum of 8 axis regulation controllers connected behind one power supply, all drives can be braked via a d.c. link short circuit and individual ones can also be braked via the motor winding short circuit.

4.5.1.2 Switching suggestions for stopping the drives using hardware for gantry axis operation



Stop

The following information must be observed at all costs for gantry axis operation.

For gantry axis operation the aim is to bring the axes of a supply module to a standstill as parallel as possible in an EMERGENCY OFF situation, i.e. to keep the mechanical offset of the axes as low as possible.

As a consequence, several problems and basic rules can be derived which must be observed at all costs and must be taken into consideration in the following switching suggestions.

- Switching off of a single axis of the gantry by means of an external protective circuit must be prevented.
- The inputs Quick-braking clockwise and Quick-braking anti-clockwise (X1.2 and X1.3) on the axis regulation controllers must be wired in parallel for all axes of the gantry. This prevents one axis from being switched off.
- An unintentional deceleration of the gantry axes (braking at the current limit, coasting or d.c. link short circuit) can lead to mechanical offset between the individual axes.
- The enabling input (X6.3) may not be used for switching off, in order to prevent braking at the current limit (mechanical offset possible). However, this is also a useful measure for preventing re-start. This means that the enabling input may only be switched on when the axes are switched off: as long as the axes are still active this input must be at 24 V
- The quick-stop inputs in one direction of all axis regulation controllers of one supply module must be switched in sequence with contact K1 (mains contactor, EMERGENCY OFF immediately recognised).
- Appropriately long distances are necessary for intentional deceleration. This becomes evident particularly when disconnecting the limit switches. The limit switches Max and Min must be shifted to the inside corresponding to the maximum speed. The travelling range available is thereby reduced.
- The longer distances must be taken into account in the construction.
- Appropriately longer times are necessary for intentional deceleration. It must be taken into consideration if this is permissible in an EMERGENCY OFF situation or if quicker braking is necessary with possible offset of the axes. If longer times are permissible, an appropriately longer slow-release time can be selected for the timing relay KT1 making braking at the quick-stop ramp possible. The safety function "Braking via d.c. link short circuit" is only effective after this.

Suggestion gantry I: Braking of all axes at a preset quick-stop ramp by residual energy from the d.c. link circuit (compare Fig. 58).

- This suggestion may only be used for plants which present no danger to persons or to the surroundings when this protective circuit is used. The enabling input is laid with fixed wiring at 24 V. When either a limit switch or an EMERGENCY OFF is activated the mains contactor is switched off and all motors at a preset quick-stop ramp are braked to a standstill; the d.c. link voltage is not switched off. By this procedure the axes remain parallel but the braking distance increases. The axis regulation controllers and the supply module must remain ready to run.

- Additional limit switches in sequence to "Regulator off", further out in the motion distance, can be planned. If these are activated, the d.c. link circuit is switched off and braking without offset can no longer be ensured.

Suggestion gantry IIa: Braking of all axes at a preset quick-stop ramp by residual energy from the d.c. link circuit followed by d.c. link short circuit (compare Fig. 58).

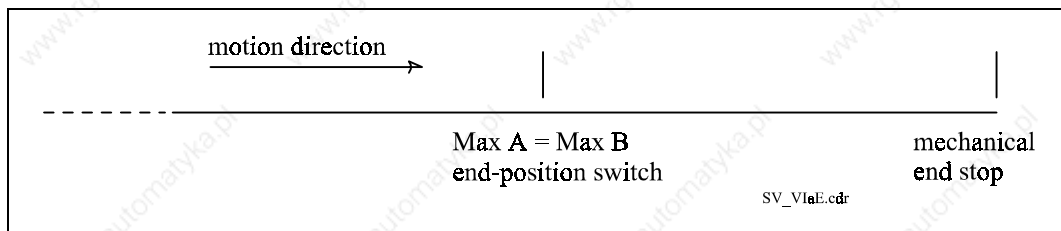

Fig. 59: Limit switch switching suggestion gantry IIa gantry axes

- In this switching variation there is no mechanical offset of the gantry axes but the braking distance is longer.
- The limit switches (Min and Max) must be used with two contacts each. One contact (A) sets off the braking at the quick-stop ramp; the other one (B) induces the application of the time-delayed relay KT1 (actual limit switch function). Contacts A and B are spatially together.
- If one of the limit switch contacts A (quick-stop input) of an axis regulation controller is activated, the braking of all gantry axes is carried out at the quick-stop ramp. The mains contactor remains engaged.
- If one of the limit switches B (actual limiting contacts) of an axis regulation controller is activated, the mains contactor is switched off and the drives in the gantry brake at the quick-stop ramp.
- The slow release of the relay KT1 must be designed in such a way that it first releases, if possible under all operating circumstances, when the drives have already braked to a standstill in order to avoid mechanical offset. If the d.c. link short circuit is induced too early, it can happen that that the drives are braked too quickly and unevenly (offset).

Suggestion Gantry IIb: braking as in Suggestion gantry IIa but with better use of the maximum travelling range (compare Fig. 58).

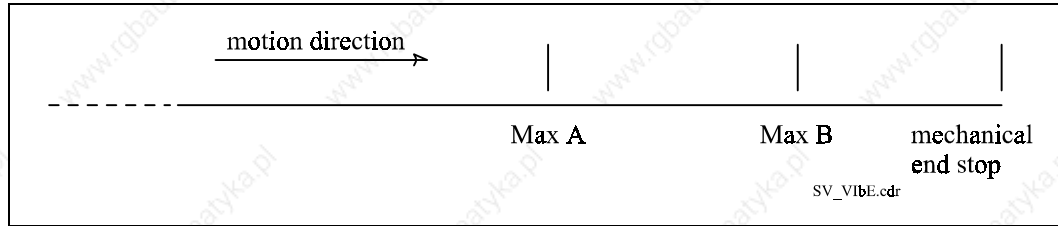

Fig. 60: Limit switch switching suggestion gantry IIb gantry axes

Instead of limit switches (Max and Min) with two contacts each per axis regulation controller, two limit switches are used respectively with one contact each. They are mounted mechanically at various positions. One limit switch (Max-A) initiates braking at the quick-stop ramp; the other one sets off the application of the slow-releasing time relay KT1.

Compared to the version Gantry IIa, this possibility has the advantage that the quick-stop switch (Max A) can also be a contact for a speed-independent end-position monitoring. This means that the travelling range used is not unnecessarily limited (orientated to the maximum speed).

Suggestion gantry III: Braking for 200 ms by residual energy from the d.c. link circuit, then d.c. link short circuit.

- Corresponds to switching suggestion III and gantry IIa/b. This switching suggestion should only be chosen when the shortest possible braking distance is required, as it can cause mechanical offset of the axes.
- The configuration is the same as suggestion gantry II but the enabling input(X6.3) is switched via contact K1 and the release delay of the relay KT1 is 200 ms.
- This means that when the limit switches A (quick-stop inputs) are activated, all drives are decelerated at the quick-stop ramp without mechanical offset. However, when the limit switch B is activated the mains contactor is switched off, the release (X6.3) is removed and the drives at the current limit are decelerated for the duration of the release delay (200 ms) of the relay KT1 and then the d.c. link short circuit is induced, whereby an offset can't be ruled out.

4.5.2 Holding brake



Warning

Vertical axes must be secured against unintentional movements! There is danger of accidents and of damage to machines if the axes are not secured against unintentional dislodging.

- A motor can be fitted with a holding brake as an option.
- The holding brake is not an operational brake, it is only designed for holding the servo axis in a switched-off, i.e. de-energized condition of the machine and works according to the closed-circuit principle. It is used, for example, where vertical axes in de-energized condition must be held against the force of gravity. The holding brake becomes worn after several thousand motor revolutions against the applied brake.
- The brake release coil is switched on via the regulator enabling, i.e. the brake engages when the regulator enabling is switched off.
- In an EMERGENCY OFF situation the holding brake on every axis regulation controller engages 200 ms after the enabling (X6.3) is removed. For gantry axis operation, if the enabling input is not switched at the supply module, the holding brake first engages in an EMERGENCY OFF situation when the d.c. link voltage falls short of $U_z = 170 \text{ V}$.

Taking the wear and tear into consideration, the holding brake must be controlled as follows:

- Engaging: With programmed brake holding time the motor is ramped down to a standstill under normal conditions before the regulator enabling is switched off. When the regulator enabling is switched off the axis regulation controller:
 - first lets the brake engage
 - waits for the engaging time of approx. 50 ms (settable parameter) and
 - then switches off the motor voltage by blocking the pulse activity.
- The axis regulation controller thus **automatically** allows for the engaging time! Only in an EMERGENCY OFF situation is the brake allowed to engage at full speed.
- Release: The holding brake is released at the same time as the setting of the regulator enabling. Therefore the sequence control program must:

- first release the brake by regulator enabling when the motor is at a standstill (e.g. position control during standstill)
- only after approx. 100 ms (brake releasing time + relay time) may the motor carry out rotary motions (e.g. positioning to other points).



Stop

The user (SPS programmer) must program the release time (dwell time in position control before further motion is allowed after the brake has been released)! See doc. no. 97-550500!

- The holding brakes for the DARC system are switched via relay contacts in the axis regulation controllers (terminal X1.7+X1.8). The contact rating is 24V / 1A.
- If the holding brake is connected incorrectly or if the suppressor diode is wrongly poled, the 24 V power supply will be short-circuited via this contact when the axes are enabled (brake release), causing damage to the DARC system.
- For this reason we recommend a back-up fuse (max. 1 A medium time-lag) for the holding brakes.



Stop

Attention must be paid to correct poling of the suppressor diode during wiring!

Motor type	Holding torque	Power consumption	Coupling relay necessary
HD 55	0.5 Nm	340 mA	no
HD 70	1 Nm	270 mA	no
HD 92	5 Nm	460 mA	no
HD 115A/B/C	5 Nm	460 mA	no
HD 115E	10 Nm	900 mA	no
HD 142	18 Nm	1.15 A	yes
BMR 190	50 Nm	1.6 A	yes

Table 35: Power consumption of the holding brakes

4.6 Displays on the equipment faceplates

After switching on and during operation the LEDs on the faceplate of the supply module and the axis regulation controller function as status and operational display. In the following the significance and causes of the various messages are explained.

4.6.1 Supply module

For displaying the d.c. link voltage on the supply module (LED $U_{Z\text{ ok}}$) the following switching points are fixed with hysteresis (for voltage rise and overrange the larger value is relevant as a switching point, for voltage drop and undershoot the smaller value is relevant as a switching point):

Undervoltage: 459 V / 435 V

Overvoltage: 763 V / 737 V

4.6.1.1 Supply module with Profibus-DP interface

There are three LEDs on the device faceplate which display the status and error messages of the DARC system and the Profibus-DP interface.

LED	Status	Cause/significance
F-bus	on	Download of operating software from the supply module to the axis controllers active, or if it is not on: download error (boot phase of the system after switch-on)
F-bus	off	The Profibus-DP interface is in the status "Data exchange", system ready for operation
F-bus	flashes at about 1 Hz	The DP interface is expecting a parameter telegram from the master via the bus; data exchange is not yet possible; the Profibus-DP interface is in the status "WAIT PRM"
F-bus	flashes at about 5 Hz	The DP interface is expecting a configuration telegram from the master via the bus; a user-data exchange is not yet possible; the Profibus-DP interface is in the status "WAIT CFG"
F-bus	flashes briefly at about 1 Hz	DARC system communication via Profibus-DP is not possible, the Profibus-DP "State machine" is in an erroneous status
BTB display	on	All axis regulation controllers and VMDRs ready for operation, Parallelbus OK, terminator for Parallelbus plugged in, no overvoltage or temperature rise
BTB display	off	One of the conditions for the ON status has not been fulfilled.
U _{ZOK} -LED	on	D.c. link voltage in nominal area
U _{ZOK} -LED	off	Over- or undervoltage recognized.

Table 36: LED messages with Profibus-DP interface

4.6.1.2 Supply module with CAN bus interface (SeleCAN)

There are six LEDs on the faceplate which display the status and error messages of the DARC system and the CAN bus interface. Of these the LEDs LED1, LED2 (bicolour) and LED3 (green LED) are for the CAN bus interface.

(LED)	Status	Cause/meaning
LED1, (INIT)	red	Initialization of the CAN module (Hardware test, CAN module configuration, registering in the network).
LED1, (INIT)	green	Initialization complete. Normal operating status.
LED1, (INIT)	flashes red at 0.5 Hz	HW error discovered on CAN interface module. Initialization aborted. No communication possible.
LED1, (INIT)	flashes red at 2 Hz	HW error discovered on VMDR side. Initialization aborted. No communication possible.
LED2, (RUN)	flashes green at 0.5 Hz	Node in standby status, in this status only configuration telegrams can be received.
LED2, (RUN)	green	Node in RUN status, either 'Event' or 'Synch'
LED2, (RUN)	off	Node in initializing status.
LED3, (CAN)	on	Normal operating status of CAN
LED3, (CAN)	flashes at 2 Hz	Faulty CAN-Bus, warning limit reached (passive error)
LED3, (CAN)	off	No communication possible because disturbance on bus is too great (Bus Off)
ERR	on	Download of the operating software from the supply module to the axis controllers active. Waiting for confirmation from the CAN module. If it does not go out: download error
ERR	off	System ready for operation.
BTB	on	All axis controllers and VMDRs ready for operation, Parallelbus cable OK, terminator for Parallel bus plugged in, no overvoltage or overtemperature
BTB	off	One of the ON status conditions has not been fulfilled
U _{ZOK} -LED	on	D.c. link voltage in the nominal range
U _{ZOK} -LED	off	Over- or undervoltage has been recognized

Table 37: LED messages with the CAN bus interface (SeleCAN)

4.6.1.3 Supply module with CAN bus interface (CANOpen)

Notice

In one of the following versions of this documentation the displays on the supply module faceplate will be described.

4.6.1.4 Supply module with CAN bus interface (DeviceNet)

Notice

In one of the following versions of this documentation the displays on the supply module faceplate will be described.

4.6.2 Axis regulation controller

LED	Status	Cause/significance
BTB display	on	Axis regulation controller ready for operation
BTB display	off	Axis regulation controller not ready for operation
Enabling LED	on	Pulse-controlled inverter on (axis enabled), set by software
Enabling LED	off	Pulse-controlled inverter off (axis disabled)

Table 38: Axis regulation controller displays

This page remains blank for technical reasons

5 Commissioning the hardware

These instructions only describe the functions and steps towards commissioning relevant for the ferrocontrol DARC system! Writing operating instructions for the entire machine is the responsibility of the machine manufacturer, as is setting the procedures for commissioning, insofar as it is machine-dependent.

5.1 Commissioning



Warning

In order to minimize the risk of accident commissioning must be carried out by trained experts!

After mounting/installation/repairs have been completed particular safety hazards come to light during commissioning which can lead to increased risk of accident and to damage to the drives and the machine. These risks are caused by:

- Monitoring equipment not in operation
- Controlling errors
- Wiring errors

In order to minimize these safety hazards the protective measures described in the following must be observed.

5.1.1 Personal safety measures



Warning

For 1 minute after the supply voltage has been switched off, there are still dangerous voltages present in the DARC system and the components connected to it!

5.1.1.1 Protection against contact with live parts



Danger

Danger of accident from extremely dangerous voltage when switching cabinets are open and plastic covers have been removed!

Before beginning work on the machine:

- Switch the machine to a de-energized state with the mains switch and lock it to prevent unintentional re-starting.
- Close the main command equipment and take out the key and/or place a warning sign on the mains switch.
- Wait for the capacitors to discharge! (at least 1 min)
- After switching off the mains switch check if the d.c. link voltage is under 50 V.

Before commissioning of the equipment/machine/plant:

- As a protection against accidental contact with live parts fix on and screw all covers, blanking caps etc.!
- Check the protective conductor connections on all motors and electrical equipment!
- If switching cabinets and other accessible live electrical fixtures can't be closed during commissioning, they must be safeguarded by electrically trained personnel to ensure that persons in danger do not have access to them.

The following terminals on the equipment have dangerous voltages:

L1, L2, L3	Mains voltage 3 x 380 - 415 V 50/60 Hz
U, W, V	Motor voltage 600 V
L+, L-	D.c. link voltage 600 V DC
R1, R2	D.c. link voltage 600 V DC
D1, D2	D.c. link voltage 600 V DC



Stop

Do not use fault-current protection equipment: FI circuit-breakers may generally not be used in connection with AC servo drives. For operational equipment with pulsed power electronics, in the case of earth contact, fault direct current can occur which can block the release of an FI circuit breaker. Protection against incidental contact must be ensured in another way, e.g. by overcurrent protective devices.

5.1.1.2 Protection against dangerous movements

Particularly during the commissioning phase unintentional movements can be triggered by:

- NC hard-/software errors
- Measured value or incremental encoder errors
- Operating errors
- Safety functions switched off during the examination of settings or functions
- Wiring or cabling errors

5.1.1.3 Safety measures during operation of the drives

Attention

- Persons should be prevented from entering areas with moving parts by means of protective screens or fences, safety enclosures or non-contact protective devices!
- If work on live parts is necessary, a second person must be present who activates the EMERGENCY-OFF or the mains switch in case of danger.
- Only use current-insulated tools!
- Only working methods considered to be completely safe may be used!

5.1.1.4 Safety measures for servicing, maintenance and cleaning work

- Inform the operating staff about special and maintenance work before beginning!
Appoint a supervisor!
- De-activate the machine and ensure against unintentional re-starting!



Warning

Risk of accident by uncontrolled axis movement in the case of drives with absolute value encoders! After a motor or encoder has been replaced the absolute reference must be re-assessed!

5.1.1.5 Protection against unintentional start-up for AC drives in the DARC system

Machine safety requires that uncontrolled movements caused by unforeseen start-up are prevented, namely **from standstill** (protection against unintentional start-up) and **during the controlled operation of the drive**.

Safety equipment must be provided that guarantees that when **one error occurs** a dangerous situation cannot arise (VDE 0113/EN 60204, part 1, section 5.7). If an operating error or a machine or control error occurs, it must be recognized automatically as quickly as possible. Further operation of the machine when an error is present must be prevented. In this case the drives may not be able to be switched on before the error is corrected.

If a second error follows, danger to persons may not be caused. The simultaneous occurrence of two independent mistakes is rendered impossible (VDI 2853, section 3.1.2.1.1, example A).

If passive protection by means of an access block to stop persons entering or reaching into a danger zone during operation of the plant is not considered to be viable by the user, the machine manufacturer must provide additional measures as safety devices.

Starting the drive from standstill (automatic re-starting) is normally prevented by safety disconnection of the drives from the power supply via the mains contactor.

In a DARC drive system several drives are connected to one supply module. In the case where one part of the drives is in operation and another must be safeguarded simultaneously against unintentional start-up, a separate supply module should be used for every part of the drive package. This solution offers the most safety and reliability because two separate EMERGENCY-OFF circuits are available.

Because one EMERGENCY-OFF is usually sufficient, the following solution ensures the protection of individual drives of a supply module against unintentional start-up:

Switch off the supply leads to the motors via motor contactors of the drives to be safeguarded.

When using a motor contactor between the motor and the axis regulation controller for disconnecting the motor from the power supply it must be ensured that the motor contactor can only be switched in a de-energized state.

First of all, the regulator enabling must be switched off. The motor contactor may only drop out after 0.5 seconds. Switching off the regulator enabling and the drop-out delay of the motor contactor must also function in a power failure.

In this way the safety requirements are satisfied: all drives are shut down in the shortest possible time if there is a power failure or for EMERGENCY-OFF. This also prevents the contacts of the motor contactor from being worn down prematurely by current load during switching in the case of operating errors.

The use of a power contactor with a latching block is advised. When the contactor coil is triggered the contactor contacts close and remain closed even if there is a power failure. The contactor contacts are only opened again when the starting lockout is activated by triggering the auxiliary coil of the latching block.

The following power contactors with a mechanical latching block e.g. from the company Telemecanique Electrique GmbH, Ratingen, are allocated to the different DARC types:

DARC S2, S4, S6	Contactor LC1D09
DARC S9, S12:	Contactor LC1D18
DARC S18:	Contactor LC1D25
DARC S25:	Contactor LC1D40
DARC S35:	Contactor LC1D50

All the listed contactors are fitted with the mechanical latching block LA6DK2.

Thus, re-starting after restoration of supply cannot occur as the central mains contactor has dropped out after a power loss and the drive system remains disconnected from the mains.

The safest but also the most complicated method of switching off the motor behind the axis regulation controller is carried out using a hand-operated three-terminal disconnecter in a de-energized state.

In cases where drives must remain active for position control during a standstill, standstill monitoring must be provided which immediately disconnects the drive from the mains in the case of unintentional start-up resulting from an error. The short motion until the axis can move freely may not be allowed to cause danger. Although this monitoring is complicated, in some cases it is absolutely necessary, as the following error monitoring, according to safety experts, does not offer sufficient

personal protection in most of its applications, because if an error occurs in the drive or in the control (e.g. software error), There is no complete guarantee that the drive comes to a standstill and is switched off.

5.1.2 Switching on for the first time

Notice

In the following description it is assumed that the respective current firmware for the DARC system has already been loaded residually into the Flash-Eprom via the service interface (see also Chapter 6.2 and 6.3)

- Check the allocation of axis regulation controller and motor according to the nameplate and Table 8.
- Compare the nominal voltage and nominal current of the equipment and make sure that the maximum permissible nominal supply voltage is not exceeded by more than 10%, even in the least favourable conditions.
- Before switching on the machine, take care that no-one is in danger from the machine/plant starting up.



Warning

Before commissioning check that the mains specifications correspond to those of the supply module (compare with the nameplate of the supply module). The installed motors must be designed for the supply voltages of the axis regulation controllers (insulation class F).

- Before commissioning, check that all terminal connections sit properly and are in perfect condition. Subminiature plugs must be screwed on.
- All leads must be checked for short circuit, interruption, proper coding, lead cross section and correct connection according to the terminal connection diagram. The lead cross sections must be selected in such a way as to ensure that no overload of the leads occurs at the maximum ambient temperature and the corresponding currents (compare Standard DIN VDE 0113).



Danger

Danger of accident is caused by extremely dangerous voltage when switching cabinet doors are open and plastic protective covers are removed!

The DARC system may only be operated when the protective plastic covers of the DC bus connections (shock protection) are screwed in place. All connections to the terminals under these covers are charged with very dangerous voltage when the power is switched on.



Stop

Between switching off the axis regulation controller and switching it on again a period of $t = 3$ min must elapse, otherwise the electronics can be destroyed!

After carefully checking the installation of the DARC system, the following **switch-on sequence** must be observed:

- Isolate the motor contactors with a latching block (if available)
- Open EMERGENCY-OFF switch.
- Switch on 24 V power supply for the electronics on the supply module and the axis regulation controllers.
- Switch on the 24 V power supply of the periphery (limit switch etc.) if it is not identical to the power supply for the electronics of the DARC system.
- Up to DARC firmware V 1.4 the 24 V periphery must be switched on before or simultaneously to the 24 V power supply of the electronics. This ensures that there are no error messages after the system acceleration.
- Switch on the mains switch for the power supply.

The following messages are displayed during the acceleration phase of the system by means of LEDs on the supply module or on the axis regulation controllers:

When using the Profibus-DP interface:

- 24 V power supply to the supply module and the axis regulation controller:
 - All BTB-LED indicators are on briefly (0.5 s) (initialization phase).
 - Enabling LED on the axis regulation controller always off during acceleration.
 - The U_Z LED and the fieldbus LED are off.
 - After approx. another second the fieldbus (F-bus) LED comes on. The software for the axis regulation controllers is loaded from the supply module (download phase).
 - After the download phase the axis regulation controllers indicate that they are ready for operation (BTB indication). If all BTB indicators of the connected axis regulation controllers are on and the supply module is ready for operation, the BTB indicator on the supply module also lights up.
 - The ready-for-operation enabling (terminal X6.2) is available. The mains contactor can be switched on.
 - The d.c. link voltage is built up and when the undervoltage threshold has been exceeded the U_Z LED lights up.

When using the CAN bus interface with SeleCAN:

- 24 v power supply to the supply module and the axis controller:
 - All BTB (ready for operation) displays are on briefly (0.5 s) (initialization phase).
 - Enabling LED on the axis controllers is always off during acceleration phase.
 - The U_Z LED is off.
 - LED1 is red. The CAN module is being initialized and the HW tested. Subsequently confirmation is sent to the VMDR module and the enabling from the VMDR module is awaited.
 - The F-bus LED is also on. The VMDR module loads the software of the axis controllers (download phase) and waits for confirmation from the CAN module.
 - After confirmation from the CAN module, the supply module tests the Dual-Port RAM, initialises the variables in the DPR and sends confirmation to the CAN module. The F-bus LED goes out.
 - After the download phase the axis controllers display that they are ready for operation (BTB display). If all BTB displays of the connected axis controllers are on and the supply module is ready for operation, the BTB display on the supply module lights up.

- LED1 changes to green. LED2 begins to flash, signalling standby status. LED3 is on. If it flashes or is off, the CAN connection must be checked.
- The ready-for-operation enabling (terminal X6.2) is available. The mains contactor can be switched on.
- The d.c. link voltage is built up and when the undervoltage threshold has been exceeded the U_Z LED lights up.

When using the CAN bus interface with CANOpen:

Notice

In one of the following versions of this documentation the messages which are displayed by LEDs on the supply module or on the axis controllers during the acceleration phase of the system will be described.

When using the CAN bus interface with DeviceNet:

Notice

In one of the following versions of this documentation the messages which are displayed by LEDs on the supply module or on the axis controllers during the acceleration phase of the system will be described.

This completes the acceleration phase and the DARC system is ready for operation.

Access to the DARC system from an overriding automation device via the fieldbus or via the RS232 service interface is possible. This status can be recognized by the terminal X6.2, BTB output = 24 V on the DARC system.

The DARC system can be parameterized and configured by the overriding automation device via the fieldbus.

When parameterizing for the first time (setting up), it is advisable to use the service tool (DARCTOOL) via the RS232 service interface. This allows you to set the parameters (objects) comfortably and interactively and to store them in the DARC system, as well as to test the essential functions of the drives on the machine (plant).

When starting again after successfully parameterizing for the first time, the initializing values for the object entries (parameter values) are loaded automatically, parameterizing again via the service interface RS-232 is not necessary.

This page remains blank for technical reasons!

6 Operation with the service interface

6.1 General information

Complex automation technology plants require an effective and radical possibility of monitoring, i.e.

- insight into the system, in particular the retrieval of conditions
- influencing, intervening in the system

under various conditions:

- initial commissioning
- plant-specific basic parameterization
- subsequent altering or optimization of the settings
- service and regular maintenance
- malfunctions

For this purpose, two interfaces are available to the DARC system as partial components:

When it is integrated into a CAN or Profibus-DP-Fieldbus system, the DARC system can be parameterized, tested and commissioned via the **fieldbus or the serial service interface RS-232**.

The necessary procedures for operating the DARC system with the service interface can be found in the documentation "DARC System, Commissioning Software "DARCTOOL" Doc. no. 97-053100. *

The firmware of the components is stored in a Flash-EPROM. Before you can commission the DARC system (for example DARCTOOL), the necessary firmware for the individual components of the DARC system must be programmed via the service interface (terminal X7).

Basically, there are two possibilities of transferring the firmware to the DARC system:

1. You can use any of a number of PC terminal programs.
2. You use the program "DARC_DLD". The program is used to communicate between a compatible PC and the ferrocontrol supply module of the DARC system via an RS-232 interface.

The procedures for using these two possibilities are described in the following.

Necessary components

- PC with serial interface
- RS232 service interface cable in accordance with Chapter 3.6.1.10 (Diagram number 8.0010.01.1)
- or override potentiometer cable in accordance with Chapter 3.6.3 (Article number 35-040500)
- or standard zero modem cable

The following firmware must be transmitted depending on the features. The question marks in the file names are wildcards for the respective current firmware version.

Firmware for	File name	Comment
Supply module with CAN interface	VMCN????ABS	Filed on the supply module Flash-Eprom
Supply module with Profibus-DP interface	VMDP????ABS	Filed on the supply module Flash-Eprom
Axis regulation controller	SDRD????ABS	Filed on the supply module Flash-Eprom
Interpolator	IP_????ABS	Filed on the interpolator Flash-Eprom
CAN fieldbus interface	SLCN????ABS	Filed on the Flash-Eprom of the CAN interface card in the supply module Already transferred in delivery
Profibus-DP-fieldbus interface	-	For Profibus-DP no additional firmware is needed. VMDP????ABS contains the necessary firmware.

Table 39: Firmware for the DARC system



Warning

Make sure that all DARC system controllers are switched off during transmission!

6.2 Programming the firmware using a terminal program

Notice

Please ensure that you transmit the correct firmware to the supply module, depending on the fieldbus interface used.

Sequence for firmware update (first transmission) with the terminal program:

1. Connect the service interface (X7) to the PC serial interface.
2. Call the terminal program (e.g. Siotest.exe, Win95Sio.exe [both available from ferrocontrol] or Hyper Terminal), setting of the COM interface: 38400 baud, 8 data bits, 1 stopbit, no parity.
3. Switch on the terminal program interface (open COM-Port).
4. Switch on the 24-volt power supply.
5. If supply module firmware hasn't been loaded yet, the download mode is active immediately. Otherwise, the DARC system starts up and can be changed to download mode when a text file **.DOWNLOAD** is sent. The DARC system registers a string displaying the version number of the boot firmware.
6. The file VMDP????ABS or VMCN????ABS can now be transmitted.
7. The red LED flashes to the rhythm of the text lines received. After successful programming the appropriate message appears on the screen.
8. Transmission of the axis regulation controller firmware: as in 6 and 7, only transmit file SDRD????ABS.
9. Transmission of the interpolator firmware: as in 6 and 7, only transmit file IP__????ABS.
10. Transmission of the CAN fieldbus interface firmware (for update): as in 6 and 7, only transmit file SLCN????ABS.
11. After successful programming, switch the power supply to the DARC system off and on again.
12. The system then restarts and is ready for operation.

Notice

If no supply module firmware has been loaded yet or it has been deleted, the download mode is immediately active when the DARC system starts up.

6.3 Programming the firmware with the program "DARC_DLD"

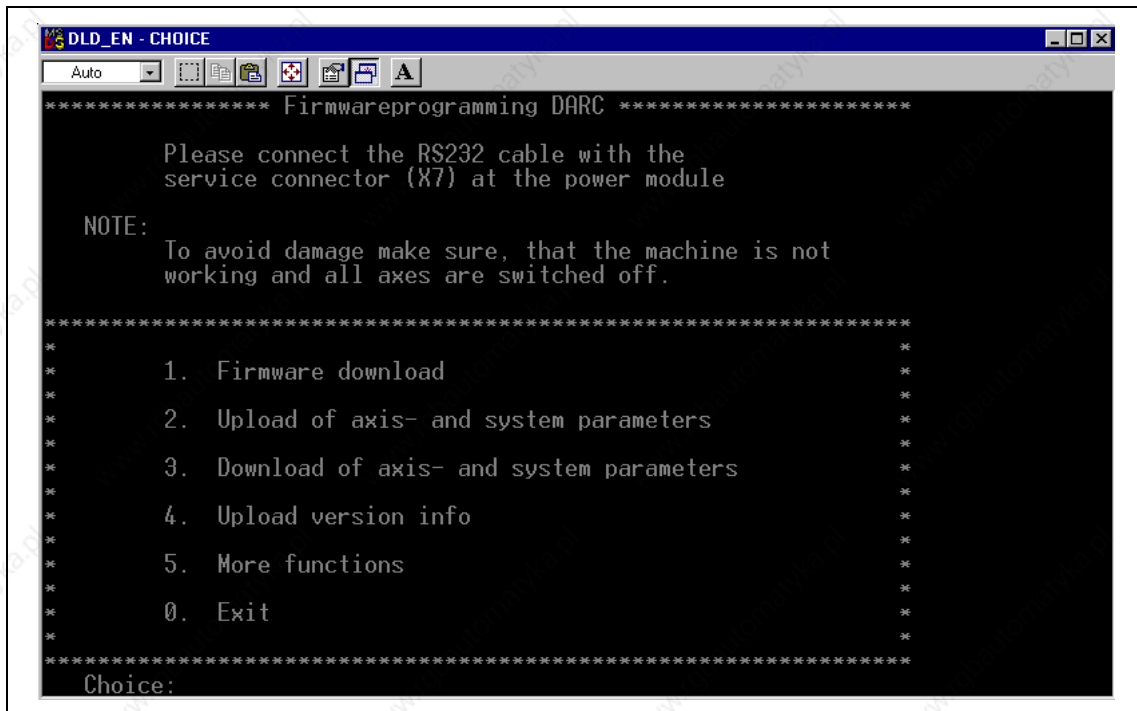

Fig. 61: Program "DARC_DLD"

The program "DARC_DLD" allows you to transmit firmware (download) to the DARC system, to interrogate the version statuses of the firmware on the DARC system, to read and re-transmit the entire axis and system parameters (DARCPARA.ABS) as well as all firmware parts including the entire axis and system parameters (FLASH.ABS). The two last possibilities are particularly relevant for purposes of archiving and restoring data.

The program package "DARC_DLD" consists of several files and one subdirectory \EXE.

The following files can be found in the main directory:

- **INSTALL.BAT:** Installs the diskette/directory contents into the directory C:\DARC_FW
- **LIESMICH:** Information about this program in German
- **README:** Information about this program in English
- **DLD_GR.BAT** Batch file for starting DARC_DLD in German
- **DLD_EN.BAT** Batch file for starting DARC_DLD in English

- DARC_DLD.INI Configure DARC_DLD
- VMCN????ABS: Supply module firmware with CAN interface
- VMDP????ABS: Supply module firmware with Profibus-DP interface
- SDRD????ABS: Axis regulation controller firmware
- IP_????ABS: Interpolator firmware for DFBIR4.0
- SLCN????ABS: Axis regulation controller firmware

Here the files which are read from the supply module are kept:

- DARCPARA.ABS, axis and system parameters of the DARC system
- FLASH.ABS, all available firmware parts (no boot firmware) as well as axis and system parameters of the DARC system

The following files can be found in the subdirectory \EXE:

- DARC_DLD.DE: Necessary for the DARC_DLD program
- DARC_DLD.DOK: Additional information about this program
- UPFLASH.BAT: Batch file for reading the entire DARC system firmware as well as the axis and system parameters. The target file where the data read are stored must be specified as the transfer parameter. Alternative data archiving possibility: the data are saved in any specified file instead of in "FLASH:ABS"
- DOWNFLSH.BAT: Batch file for transmitting the entire DARC system firmware as well as the axis and system parameters. The source file where the data are stored must be specified as the transfer parameter. Alternative possibility for restoring the data: the files are transferred to the DARC system from the specified file instead of from "FLASH:ABS".
- DARC_DLD.EXE: DARC_DLD program
- LOAD927.HEX: Necessary for firmware download CAN interface
- FIRST.HEX: Necessary for firmware download CAN interface
- CHOICE.COM: MS-DOS operating system file

Notice

If you want to transmit firmware to the supply module (VMDR), connect the cable to X7 (Service).

If you are transmitting (first transmission or update) the firmware only the boot firmware needs to be on the supply module (delivery status). It is not absolutely necessary that other firmware has already been transmitted.

First check the entries in the configuration file an DARC_DLD.INI and adapt them if necessary.

From this the program DARC_DLD acquires the setting for the service interface and the file names of the individual firmware parts to be loaded.

The following sections are possible:

[RS232] : Serial interface setting
COMx:baud rate : e.g. COM2:38400
IRQx : e.g. IRQ4

[CAN] : Section for DARC with CAN interface
File name : File(s) for VMDR with CAN interface, e.g.
VMCN9106.ABS
SLCN0101.ABS

[DP] : Section for DARC with Profibus-DP
File name : File(s) for VMDR with DP interface, e.g.
VM DP0106.ABS

[SDR] : Section for axis regulation controller,
the data entered here are always sent.
File name : File(s) SDR, e.g.
SDRD0318.ABS

[DFBIR] : Section for interpolator
Dateiname : File(s) for interpolator, e.g.
IP_9101.ABS

Now call the batch file DLD_GR.BAT (German version) or DLD_EN.BAT (English version) to start DARC_DLD. The start menu appears showing the selection possibilities for download/upload.

7 Manufacturer's declaration

We hereby declare that the electrical DARC system as described in these instructions is intended to be a component for controlling speed- variable synchro-motors built into a machine or for assembly with other components to a machine. The DARC system itself is not a machine in the sense of the machine guideline 89/392/EWG.

Notices and recommendations about installation and the intended use are contained in these operating instructions.

Commissioning is forbidden until it has been clearly established that the protection and safety requirements of the machine guidelines 89/392/EWG with the alterations 91/368/EWG have been met.

In these instructions measures are described whereby the DARC system keep within EMC limits in a typical EMC configuration. The electro-magnetic compatibility of the machine depends on the type of installation carried out and the care taken. The responsibility for observing the EMC guidelines 89/336/EWG with the alterations 92/31/EWG in the machine application lies with the end-user.

Observed norms and regulations :

The observed norms and regulations are listed together in the norm survey in Chapter 8.1.1.

This page remains free for technical reasons!

8 Appendix

8.1 Further documentation

8.1.1 Norm survey

In the following you will find the most important German, national and international norms which are significant for the DARC system:

Validity	Germany DIN VDE norm	Europe EN norm	International IEC norm
Profibus Part 1-3	DIN 19245-1-3	EN 50170	
Profibus Profile for motion control and drives	VDE 3689		
Interbus-S DriveCom-Profile 20-22	DIN 19258		
CAN in Automation communication and device profiles	CIA 201-207, 301, 401, 402		IEC 11898
Fitting of power installations with electronic devices	DIN VDE 0160	pr EN 50178	
Motors	DIN VDE 0530	EN 60034	IEC 34-1
Chokes, transformers	DIN VDE 0532		IEC 76-1 IEC 14 (CO) 75
Cables, insulated leads	DIN VDE 0250 DIN VDE 0471 DIN VDE 0289 DIN VDE 0113	EN 60204-1	IEC 2004-1 IEC 550
Installing power installations under 1000V	DIN VDE 0100		IEC 64
Operation of power installations	DIN VDE 0105		IEC 64
Safety classes, dangerous shock currents	DIN VDE 0106		IEC 64
Insulation coordination, creepage distances and clearances of all equipment	DIN VDE 0110		IEC 664
Electrical equipment and safety of machines	DIN VDE 0113	EN 60204-1 EN 418	IEC 204-1 IEC 550

Table 40: Norm survey part 1

Validity	Germany DIN VDE norm	Europe EN norm	International IEC norm
EMC (electro-magnetic compatibility)			IEC 801
Small transformers	DIN VDE 0550		
Insulation, insulation systems	DIN VDE 0302		IEC 505
Semiconductor converter	DIN VDE 0558		IEC 22B (CO) 50
Discharge of static electricity (ESD):		EN 50082-2, 8.92	
Quick, transient disturbance (burst):		EN 50082-2, 8.92	
Surge voltage, lightning strike:			IEC 1000-4-5
Radio interference suppression of electrical operational equipment and installations:		EN 50081-2; EN 55011	
Determining of creepage distances and clearances:	DIN VDE 0110 part 1-2 , 1.89; DIN VDE 0110 Part 20, 8.90		
IP degrees of protection:		EN 60529, 10.91	
Basic material for printed circuits:	DIN IEC 249 Part 1, 10.86,; DIN IEC 249 Part 2-15, 10.89		
Printed circuits, printed circuit boards:	DIN IEC 326 Part 1, 10.90; EN 60097, 9.93		
Insulation resistance	Overvoltage category III acc. to VDE 0110		
Vibration resistance			IEC 68-2-6 test Fc
Damp stress		EN 60068-2-3 Ca	IEC 68-2-3 / 2.1 Ca

Table 41: Norm survey part 2

8.1.2 Documentation register ferrocontrol

Doc. no.	ferrocontrol documentation	Lang.
96-100500	DARC Inbetriebnahme/Service	German
96-101000	DARC Service manual	English
96-102000	RS-232-SchnittstellenDescription DARC Protokoll RS 232	German
96-100501	DARC Produktdokumentation	German
96-510000	ferrocontrol CNC-Feldbus Teil: Gerätebeschreibung	German
96-511000	ferrocontrol CNC Fieldbus Part: Equipment summary	English
96-520500	ferrocontrol CNC-Feldbus Teil: Inbetriebnahme / Service	German
96-521000	ferrocontrol CNC Fieldbus Part: Commissioning / Service	English
96-600500	Betriebsanleitung FIPC	German
96-601000	Instruction manual FIPC	English
96-700500	Bedienfeld mit Display TSED-RS485	German
97-400500	Einführung ferrocontrol-Bedienoberflächen	German
97-500500	Benutzer- und Referenzhandbuch Applikationsgenerator	German
97-501000	User and Reference manual Application Generator	English
97-550500	Programmierhandbuch FPS	German
97-551000	Programming manual PLC	English
97-880500	Doppeldiagonalsäge mit DARC, V.1	German
97-881000	Tandem diagonal saw with DARC, V.1	English
97-880501	Doppeldiagonalsäge mit ferrocontrol-Feldbus und DARC, V.2	German
97-881001	Tandem diagonal saw with ferrocontrol Fieldbus and DARC, V.2	English

Doc. number	ferrocontrol documentation	Lang.
The following documentation is relevant for the DARC system with CAN and Profibus-DP		
96-051000	ferrocontrol MAS, System Handbuch Hardware	German
96-051100	ferrocontrol MAS, System Manual Hardware	English
96-857000	DARC-System, Produktdokumentation	German
96-858000	DARC System, Product Documentation	English
96-401000	DARC-System, Inbetriebnahme Hardware	German
96-401100	DARC System, Commissioning Hardware	English
97-051000	DARC-System, Software SeleCAN	German
97-051100	DARC System, Software SeleCAN	English
97-051500	DARC-System, Software CANOpen	German
97-051600	DARC System, Software CANOpen	English
97-052000	DARC-System, Software Profibus-DP	German
97-052100	DARC System, Software Profibus-DP	English
97-052500	DARC-System, Programmierung	German
97-052600	DARC System, Programming	English
97-053000	DARC-System, Inbetriebnahme Software DARCTOOL	German
97-053100	DARC System, Commissioning Software DARCTOOL	English
97-053500	ferrocontrol MAS, Systemhandbuch Software	German
97-053600	ferrocontrol MAS, System Manual Software	English

Table 42: List of ferrocontrol documentation

8.2 List of abbreviations

- **MMI** Man-machine interface
- **DARC** Digital Axis Regulation Controller i.e. the whole DARC system
- **INC** Incremental position encoder interface
- **IPC** Industrial PC
- **IPM** Interpolation computer module (integrated into SMDC)
- **LED** Light emitting diode
- **SAE** Serial absolute value encoder
- **SDR** printed circuit board digital controller, i.e. axis regulation controller
- **SSI** Serial synchronous interface
- **VMDR** Versorgungsmodul digitaler Regler (supply module digital controller)
- **SCF** Status checking field (16-bit inputs at the supply module)
- **BTB** Betriebsbereit (ready for operation)
- **SPC** Stored Program Controller

8.3 Tables and parameter lists

8.3.1 D.c. link voltage

D.c. link voltage	Upper operating point	Lower operating point
Recognition undervoltage U_{\min}	459 V	435 V
Recognition overvoltage U_{\max}	763 V	737 V
Activation braking resistor	700 V	677 V

Table 43: Operating points D.c. link voltage

8.3.2 LED messages on the supply module faceplate with Profibus-DP interface

LED	Status	Cause/meaning
F-bus	on	Download of operating software from the supply module to the axis controllers active, or if it is not on: download error (boot phase of the system after switch-on)
F-bus	off	The Profibus-DP interface is in the status "Data exchange", system ready for operation
F-bus	flashes at about 1 Hz	The DP interface is expecting a parameter telegram from the master via the bus; data exchange is not yet possible; the Profibus-DP interface is in the status "WAIT PRM"
F-bus	flashes at about 5 Hz	The DP interface is expecting a configuration telegram from the master via the bus; a user-data exchange is not yet possible; the Profibus-DP interface is in the status "WAIT CFG"
F-bus	flashes briefly at about 1 Hz	DARC system communication via Profibus-DP is not possible, the Profibus-DP "State machine" is in an erroneous status
BTB	on	All axis controllers and VMDRs ready for operation, Parallelbus cable OK, terminator for Parallel bus plugged in, no overvoltage or overtemperature
BTB	off	One of the ON status conditions has not been fulfilled
U_{ZOK} -LED	on	D.c. link voltage in the nominal range
U_{ZOK} -LED	off	Over- or undervoltage has been recognized

Table 44: LED messages with Profibus-DP interface

8.3.3 LED messages on the axis regulation controller faceplate with CAN bus interface (SeleCan)

(LED)	Status	Cause/meaning
LED1, (INIT)	red	Initialization of the CAN module (Hardware test, CAN module configuration, registering in the network).
LED1, (INIT)	green	Initialization complete. Normal operating status.
LED1, (INIT)	flashes red at 0.5 Hz	HW error discovered on CAN interface module. Initialization aborted. No communication possible.
LED1, (INIT)	flashes red at 2 Hz	HW error discovered on VMDR side. Initialization aborted. No communication possible.
LED2, (RUN)	flashes green at 0.5 Hz	Node in standby status, in this status only configuration telegrams can be received.
LED2, (RUN)	green	Node in RUN status, either 'Event' or 'Synch'
LED2, (RUN)	off	Node in initializing status.
LED3, (CAN)	on	Normal operating status of CAN
LED3, (CAN)	flashes at 2 Hz	Faulty CAN-Bus, warning limit reached (passive error)
LED3, (CAN)	off	No communication possible because disturbance on bus is too great (Bus Off)
F-bus	on	Download of the operating software from the supply module to the axis controllers active. Waiting for confirmation from the CAN module. If it does not go out: download error
F-bus	off	System ready for operation.
BTB	on	All axis controllers and VMDRs ready for operation, Parallelbus cable OK, terminator for Parallel bus plugged in, no overvoltage or overtemperature
BTB	off	One of the ON status conditions has not been fulfilled
U _{ZOK} -LED	on	D.c. link voltage in the nominal range
U _{ZOK} -LED	off	Over- or undervoltage has been recognized

Table 45: LED messages with CAN bus interface

8.3.4 LED messages on the supply module faceplate with CAN bus interface (CANOpen)

Notice

In one of the following versions of this documentation the displays on the supply module faceplate will be described here.

8.3.5 LED messages on the supply module frontplate with CAN bus interface (DeviceNet)

Notice

In one of the following versions of this documentation the displays on the supply module faceplate will be described here.

8.3.6 LED messages on the axis controller front plate

LED	Status	Cause / Meaning
BTB display	on	Axis controller ready for operation
BTB display	off	Axis controller not ready for operation
Enabling LED	on	Pulse-controlled inverter on (axis enabled), set by software
Enabling LED	off	Pulse-controlled inverter off (axis disabled)

Table 46: Axis controller displays

8.3.8 Dimensions of the motors

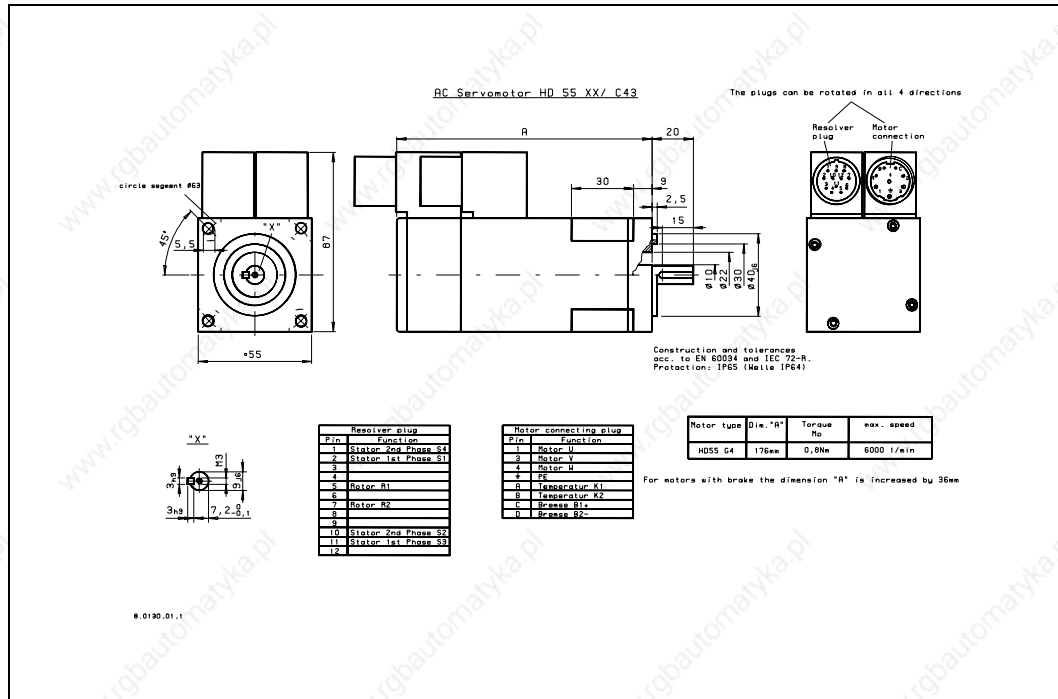

Fig. 63: Dimensions HD 55

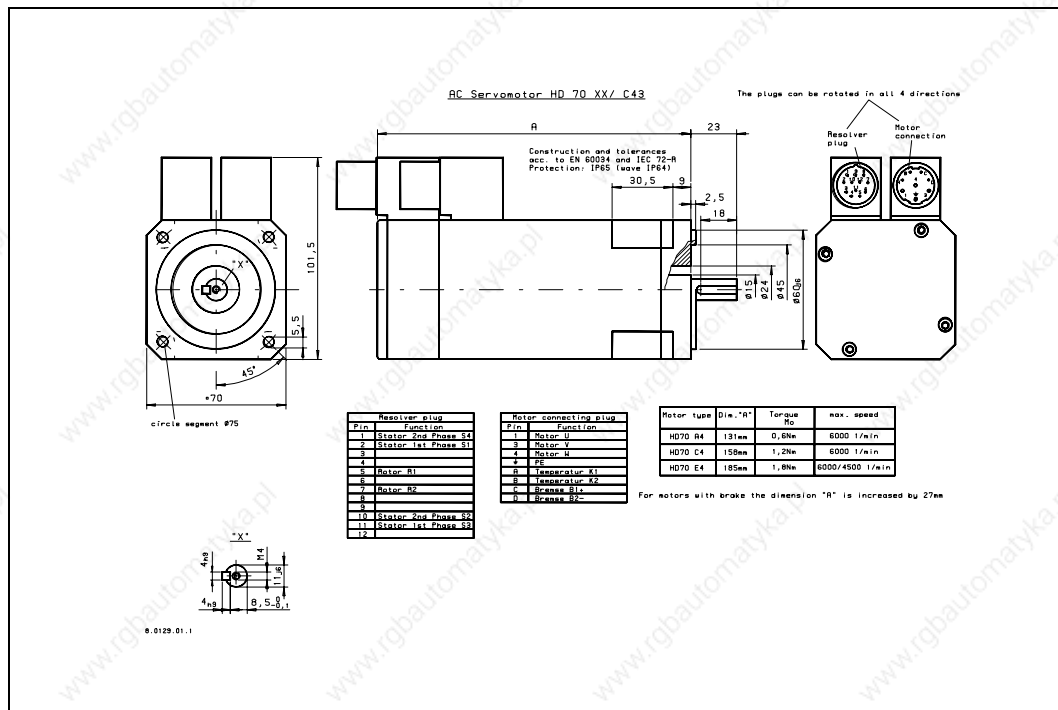

Fig. 64: Dimensions HD 70

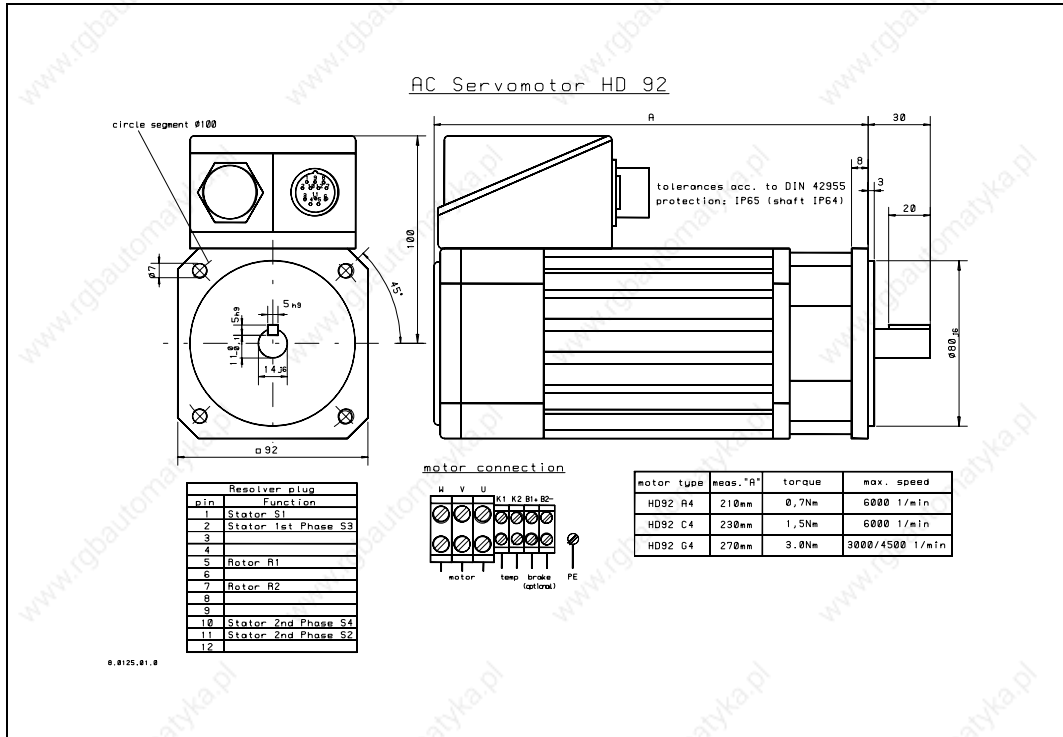

Fig. 65: Dimensions HD 92

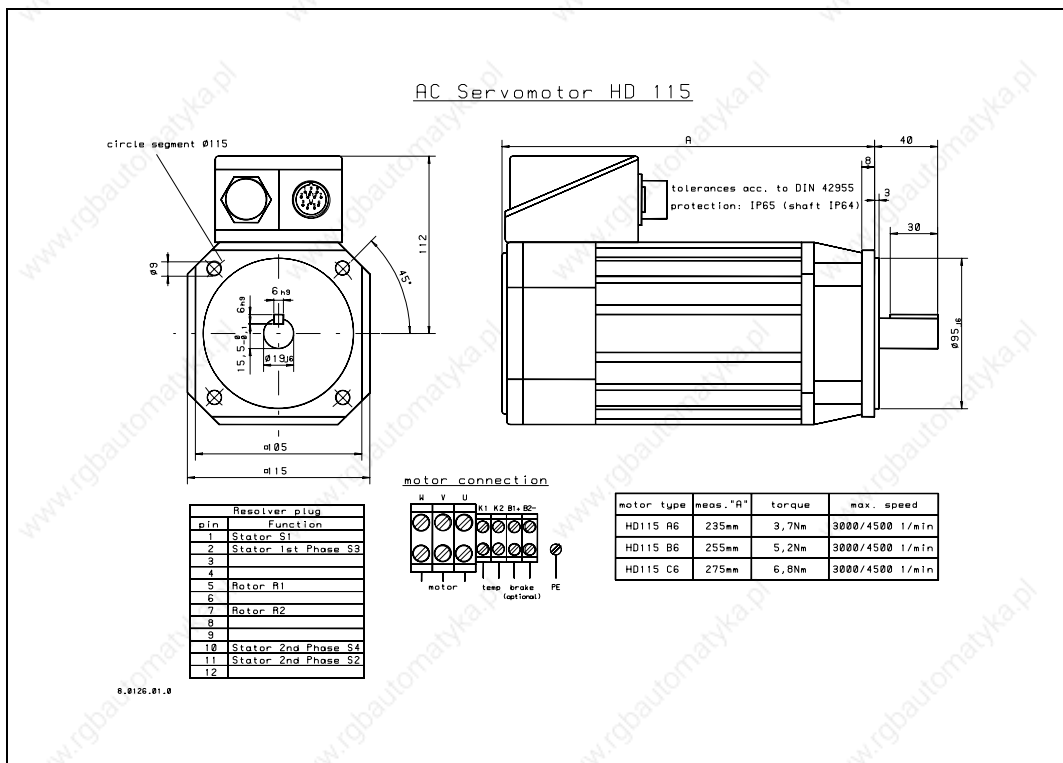

Fig. 66: Dimensions HD 115

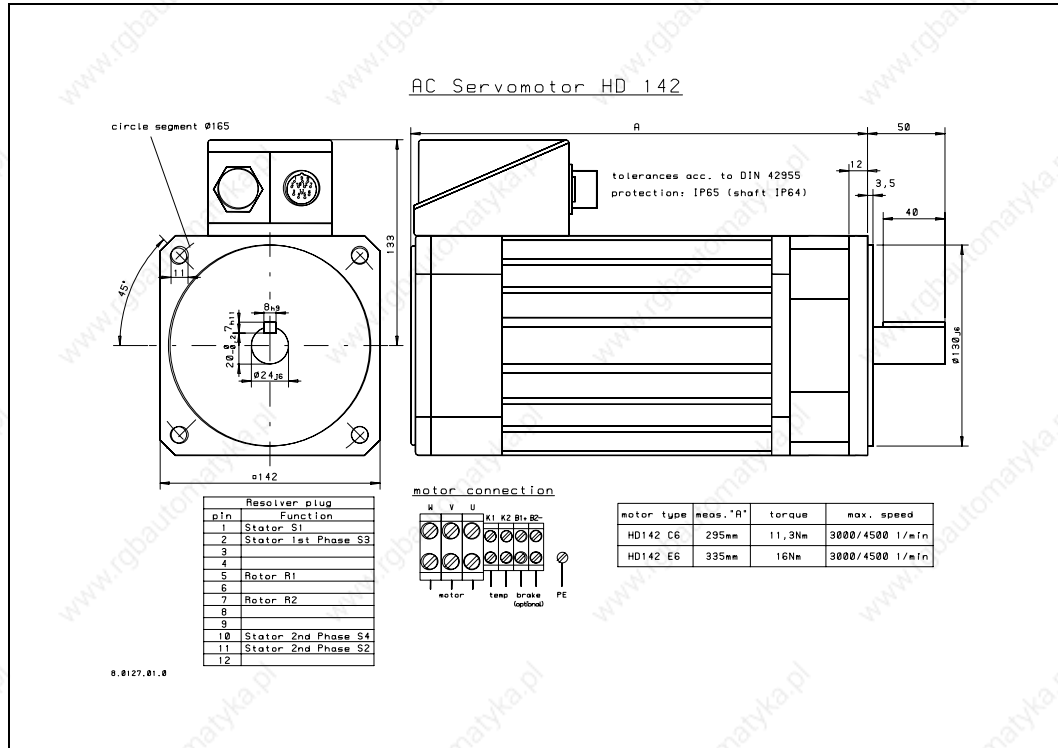

Fig. 67: Dimensions HD 142

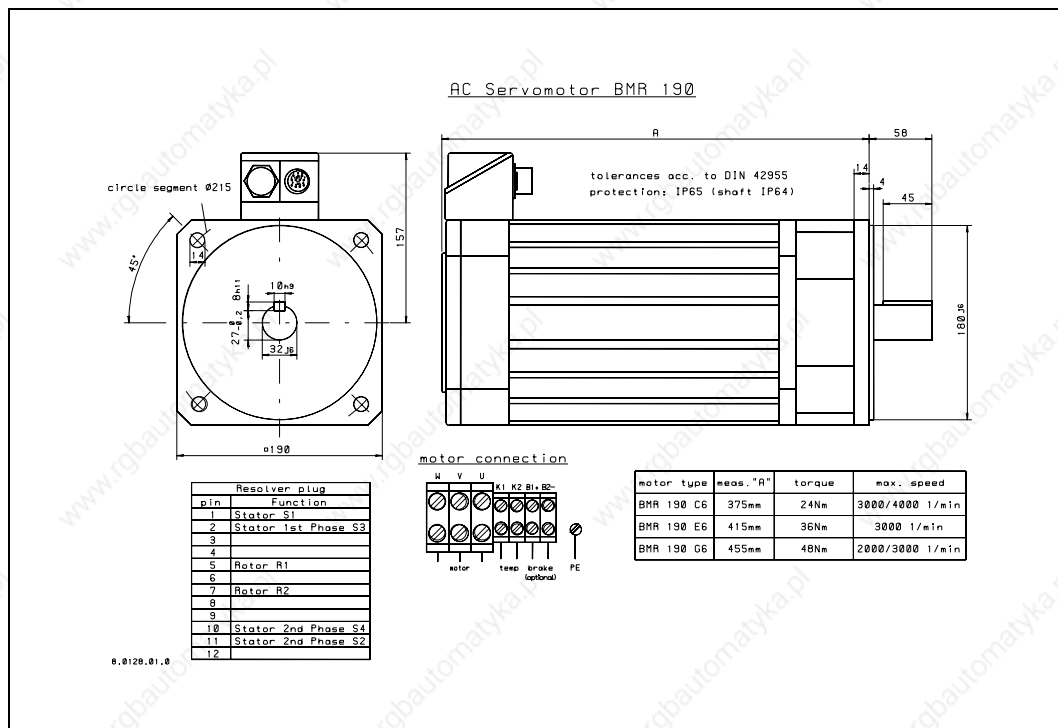

Fig. 68: Dimensions BMR 190

8.4 Dimensions of the braking resistors

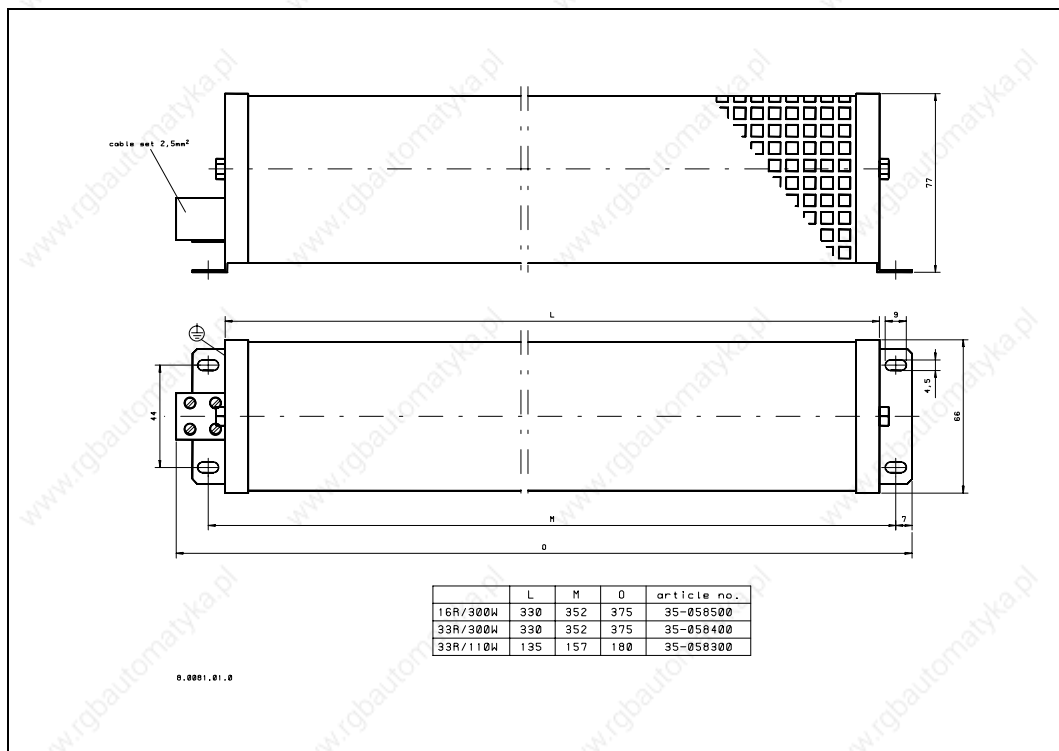

Fig. 69: Dimensions of the braking resistors

8.5 Dimensions of the d.c. link filter choke

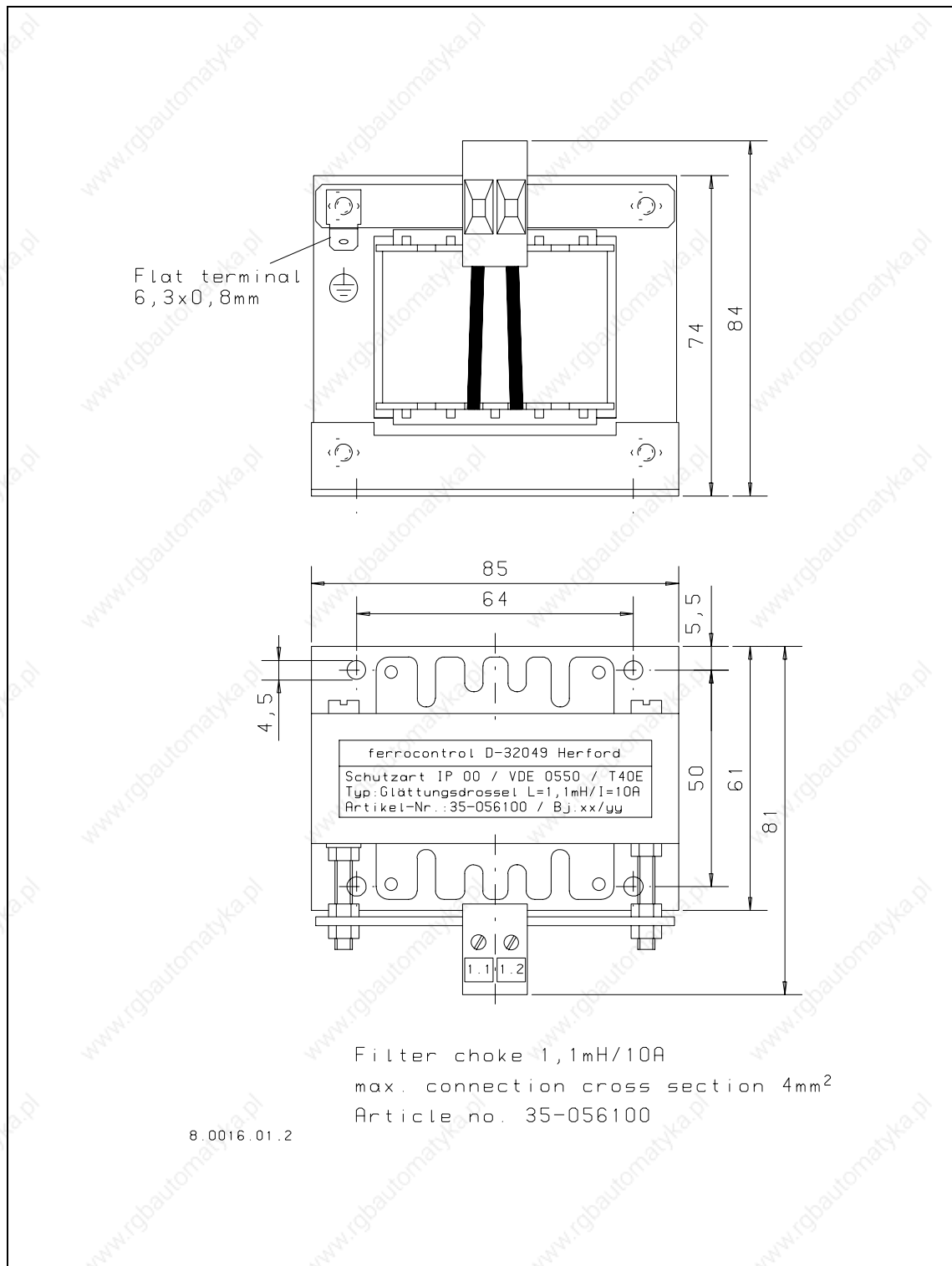

Fig. 70: Dimensions of the d.c. link filter choke for supply module V5

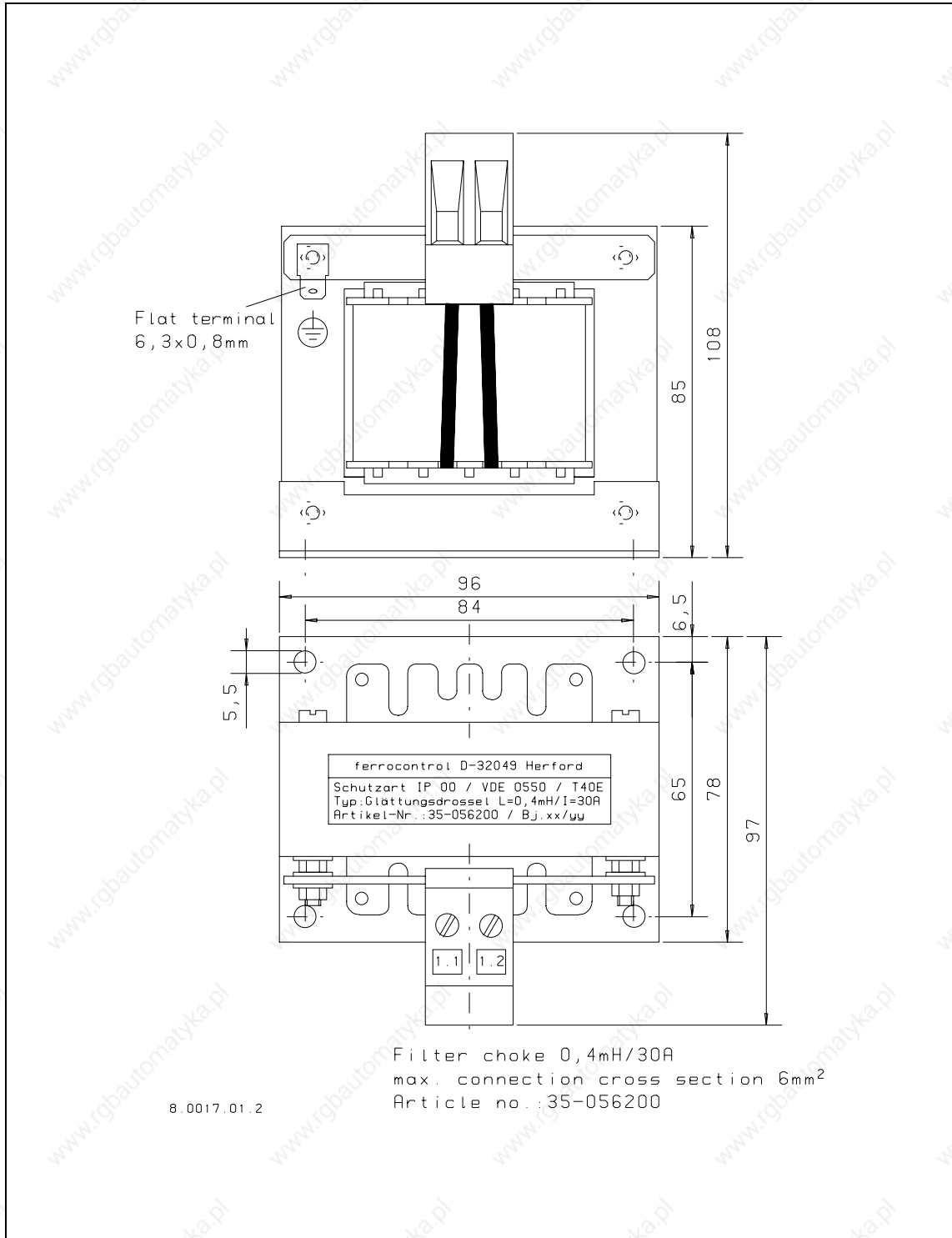

Fig. 71: Dimensions of the d.c. link filter choke for supply module V15

8.6 Dimensions and connections of the mains filter

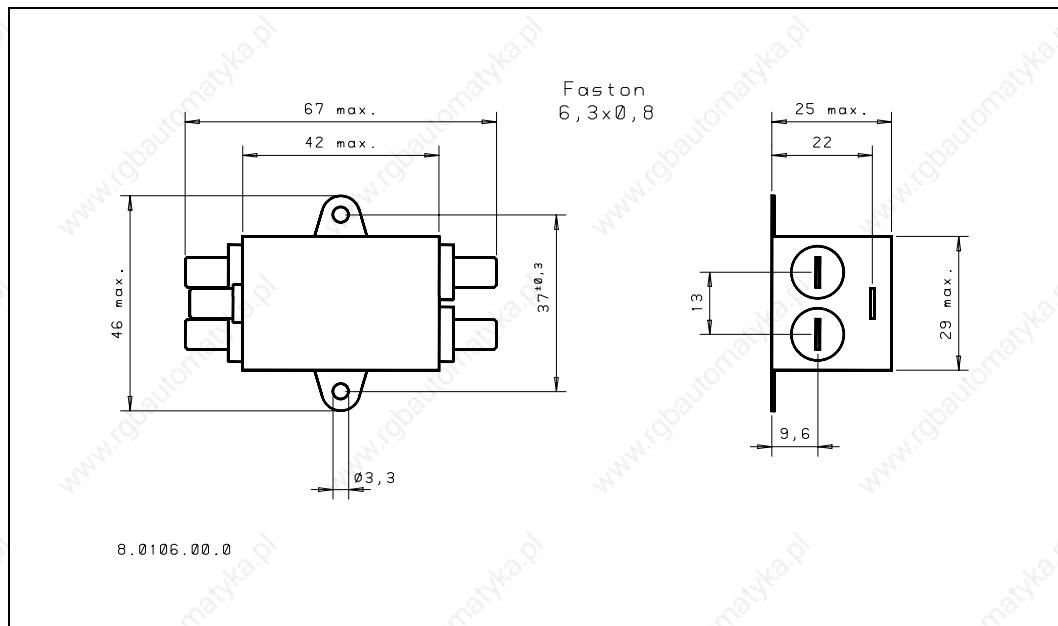
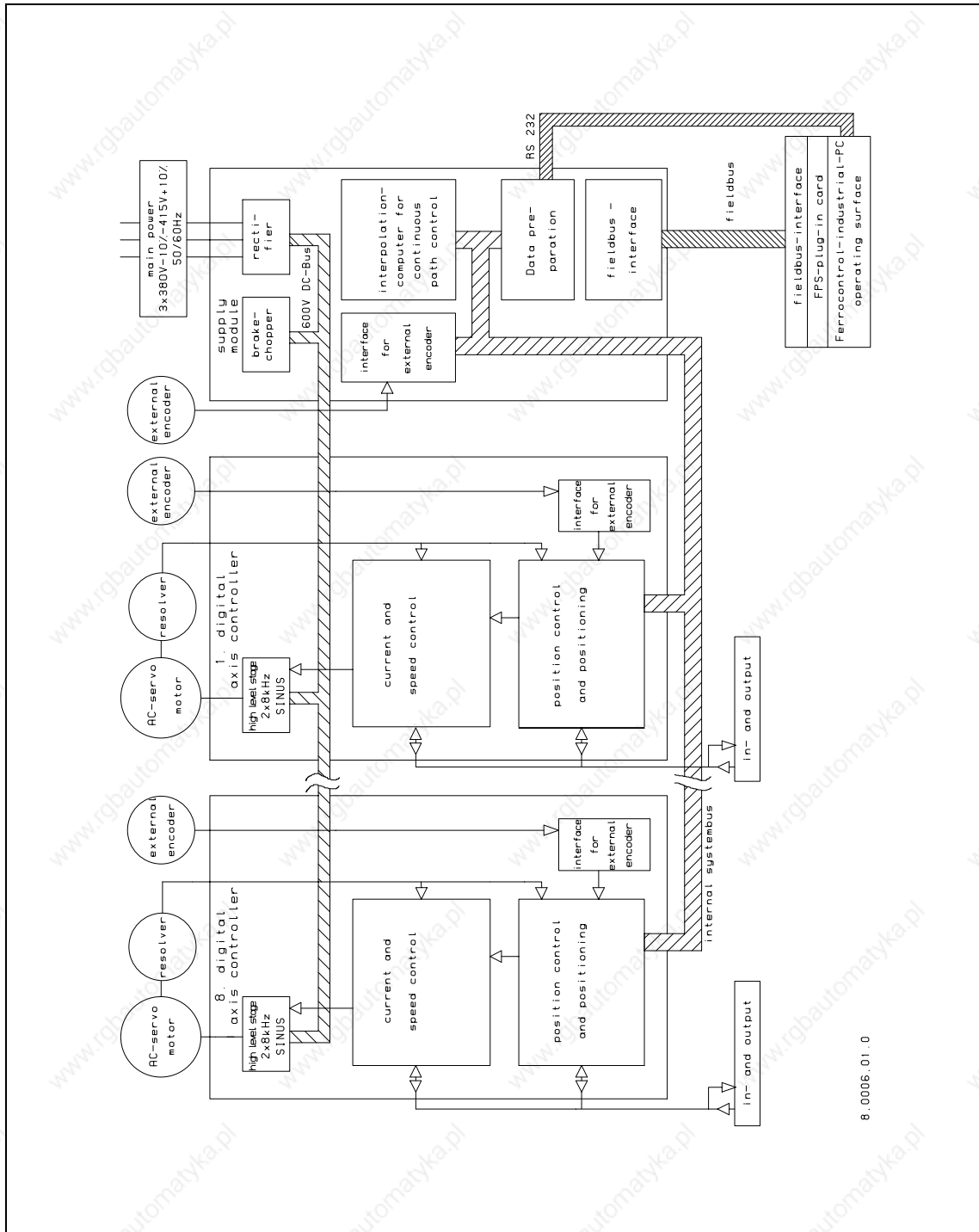

Fig. 72: Dimensions and connections of the mains filter

8.7 Schemes of the DARC system



8.0006.01.0

Fig. 73: Scheme of the DARC system (maximum equipment)

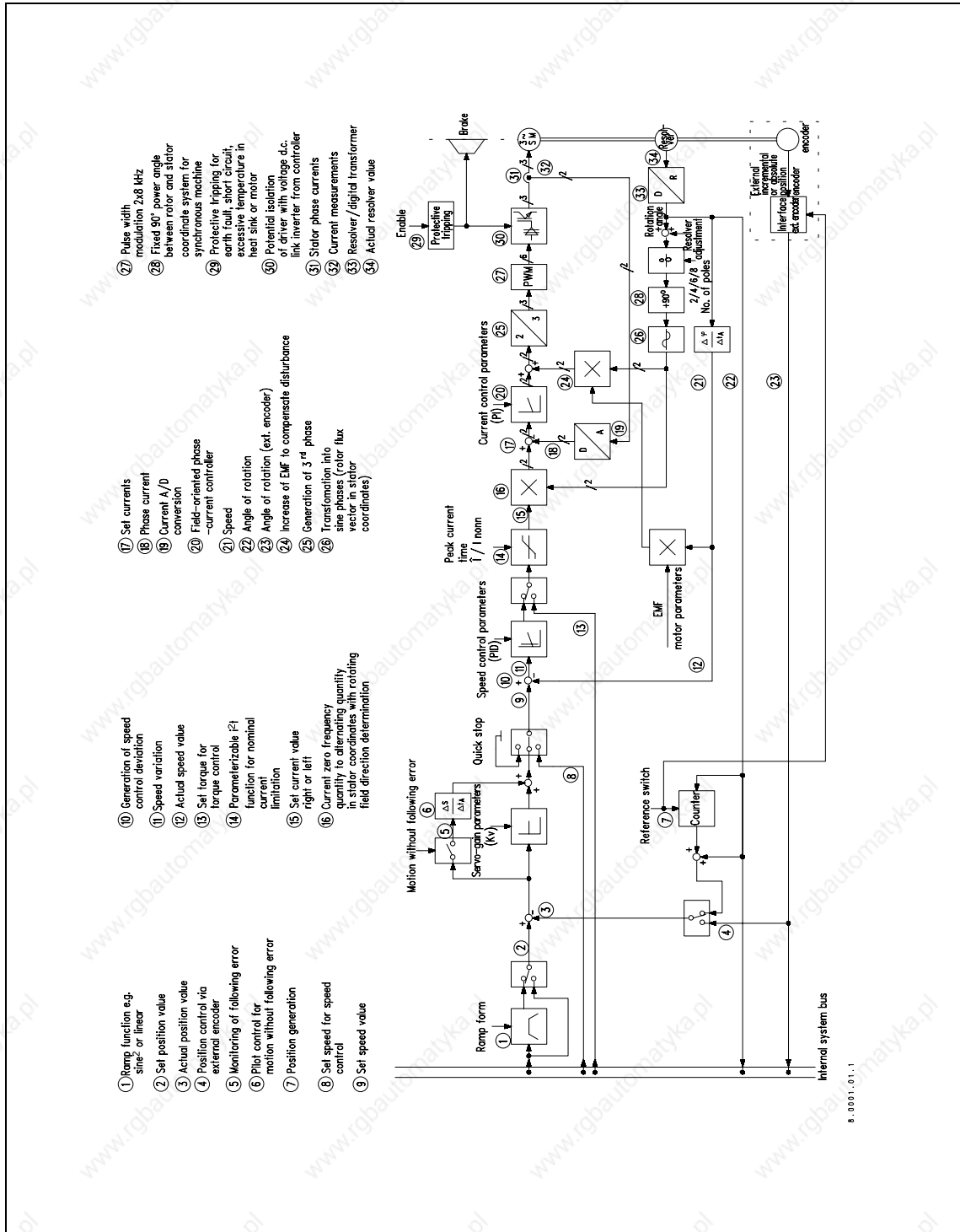

Fig. 74: Control scheme of the axis regulation controller

9 List of figures

Fig. 1: The DARC system	1.4
Fig. 2: Type code supply module.....	3.1
Fig. 3: Serial number supply module.....	3.2
Fig. 4: Type code axis regulation controller	3.2
Fig. 5: Serial number axis regulation controller	3.3
Fig. 6: Mechanical design of the DARC system	3.4
Fig. 7: Dimensions of the supply modules	3.7
Fig. 8: Dimensions of the axis regulation controller	3.10
Fig. 9: Speed/torque characteristic curve.....	3.12
Fig. 10: Motor cables.....	3.17
Fig. 11: Motor cable for HD55/HD70 (configuration from May 1998).....	3.18
Fig. 12: Resolver cables.....	3.21
Fig. 13: Absolute value encoder cables	3.22
Fig. 14: Incremental encoder cables	3.23
Fig. 15: INC-distributor cables.....	3.24
Fig. 16: Service interface cable	3.26
Fig. 17: Module bus cable (in preparation)	3.28
Fig. 18: Module bus interface (in preparation).....	3.29
Fig. 19: INC-distributor.....	3.30
Fig. 20: Override potentiometer cable	3.31
Fig. 21: Dimensions of EMC screw connection.....	3.33
Fig. 22: EMC aspects for switching cabinet construction with the DARC system... 4.5	
Fig. 23: Detail photo power connection on the DARC system	4.7
Fig. 24: DARC cable for connecting the motor.....	4.8
Fig. 25: Detail photo motor terminal board.....	4.9
Fig. 26: Large-area screen connection with screen terminals.....	4.9
Fig. 27: Laying of individual strands.....	4.11
Fig. 28: Terminal connection diagram DARC system	4.12
Fig. 29: Connections of the supply module with Profibus-DP.....	4.15
Fig. 30: Control in- and outputs	4.16
Fig. 31: Power terminal	4.17
Fig. 32: D.c. link bridges	4.18
Fig. 33: 24 V power supply	4.19
Fig. 34: Control in- and outputs	4.20
Fig. 35: SAE-absolute position encoder interface	4.21
Fig. 36: Telegram of the SSI interface for multi-turn encoders.....	4.22
Fig. 37: Incremental position encoder interface	4.23
Fig. 38: Measuring points supply module	4.24
Fig. 39: Service interface RS-232.....	4.25
Fig. 40: Service interface with override potentiometer connection.....	4.25
Fig. 41: Override potentiometer connection.....	4.26
Fig. 42: Profibus-DP - fieldbus connection).....	4.26
Fig. 43: Module addressing Profibus-DP	4.28

Fig. 44: Profibus-DP wiring	4.29
Fig. 45: Bus terminators	4.30
Fig. 46: CAN bus connection	4.32
Fig. 47: CAN bus wiring	4.34
Fig. 48: CAN bus terminators	4.35
Fig. 49: Prog/User interface for CAN busconnection	4.37
Fig. 50: Module bus connection (in preparation)	4.37
Fig. 51: Axis regulation controller connections	4.38
Fig. 52: Motor cable connection	4.39
Fig. 53: Peripheral equipment and holding brake	4.40
Fig. 54: Resolver interface	4.42
Fig. 55: Measuring points axis regulation controller	4.43
Fig. 56: Switching suggestions I-III for stopping the drives by means of hardware	4.47
Fig. 57: Switching suggestions IV for stopping the drives by means of hardware .	4.48
Fig. 58: Switching suggestions gantry I and gantry II for stopping the drives by means of hardware.....	4.49
Fig. 59: Limit switch switching suggestion gantry IIa gantry axes	4.55
Fig. 60: Limit switch switching suggestion gantry IIb gantry axes.....	4.56
Fig. 61: Program "DARC_DLD"	6.4
Fig. 62: Available motor-axis regulation controller combinations	8.9
Fig. 63: Dimensions HD 55.....	8.10
Fig. 64: Dimensions HD 70.....	8.10
Fig. 65: Dimensions HD 92.....	8.11
Fig. 66: Dimensions HD 115.....	8.11
Fig. 67: Dimensions HD 142.....	8.12
Fig. 68: Dimensions BMR 190	8.12
Fig. 69: Dimensions of the braking resistors.....	8.13
Fig. 70: Dimensions of the d.c. link filter choke for supply module V5.....	8.14
Fig. 71: Dimensions of the d.c. link filter choke for supply module V15.....	8.15
Fig. 72: Dimensions and connections of the mains filter	8.16
Fig. 73: Scheme of the DARC system (maximum equipment).....	8.17
Fig. 74: Control scheme of the axis regulation controller	8.18

10 List of tables

Table 1: Survey of available supply module versions	1.6
Table 2: Possible versions of the supply module	1.6
Table 3: Possible versions of the axis regulation controller	1.7
Table 4: General data supply module	3.5
Table 5: Electrical data supply module	3.6
Table 6: General data axis regulation controller	3.8
Table 7: Electric data axis regulation controller	3.9
Table 8: Application list DARC drive packages	3.13
Table 9: Medium d.c. link power P_{mZ} of the motor-axis regulation controller combinations.....	3.14
Table 10: Dimensioning of the multi-axis drive packages	3.15
Table 11: Survey: Minimum radii for DARC motor cables 1.x.....	3.20
Table 12: Supply module network supply cable.....	3.20
Table 13: Braking resistance and d.c. link choke cable.....	3.25
Table 14: D.c link bridge circuits	3.25
Table 15: Maximum bus cable length for different CAN cables and number of nodes (k)	3.28
Table 16: Available absolute value encoders for the DARC system.....	3.29
Table 17: Available braking resistors	3.32
Table 18: EMC screw connection	3.33
Table 19: Screen connection terminals.....	3.34
Table 20: Supply module connections (terminal X11).....	4.17
Table 21: SSI interface; Period length of the clock signal	4.22
Table 22: Measuring points supply module	4.24
Table 23: Pin configuration of the Profibus-DP interface	4.27
Table 24: Profibus-DP baud rates supported by the DARC system	4.28
Table 25: Profibus-DP line parameters	4.30
Table 26: Profibus-DP line lengths	4.31
Table 27: Pin configuration of the CAN bus interface	4.32
Table 28: Setting the bit rate on the SeleCan bus.....	4.33
Table 29: CAN bus bit rate.....	4.33
Table 30: CAN bus line parameters	4.35
Table 31: CAN bus cable lengths	4.36
Table 32: Connections axis regulation controller.....	4.39
Table 33: Resolver resolution/accuracy.....	4.43
Table 34: Measuring points axis regulation controller	4.44
Table 35: Power consumption of the holding brakes	4.58
Table 36: LED messages with Profibus-DP interface	4.60
Table 37: LED messages with the CAN bus interface (SeleCAN)	4.61
Table 38: Axis regulation controller displays.....	4.62
Table 39: Firmware for the DARC system.....	6.2
Table 40: Norm survey part 1	8.1
Table 41: Norm survey part 2.....	8.2

Table 42: List of ferrocontrol documentation	8.4
Table 43: Operating points D.c. link voltage	8.6
Table 44: LED messages with Profibus-DP interface	8.6
Table 45: LED messages with CAN bus interface	8.7
Table 46: Axis controller displays	8.8

11 Index

- 24 V power supply 3.33; 4.19
- Absolute value encoder 3.29
- Absolute value encoder cables 3.22
- Accident risk 4.1
- Address group 4.33
- Ambient temperature 3.8
- Aufbaurichtlinien Profibus-DP/FMS 4.31
- Axis controller displays 8.8
- Axis regulation controller 1.6; 3.2; 3.8; 4.38
- Axis regulation controller connections 4.38
- Axis regulation controller displays 4.62
- Basic characteristics of the drive system 1.7
- Baud rate of the CAN bus interface 4.33
- Brake holding time 4.57
- Braking resistance 3.6; 3.25; 3.32
- Braking resistor 4.50
- BTB 4.61
- BTB display 4.59; 8.8
- Bus terminator 4.31; 4.36
- Bus terminators 4.30
- Cables 3.16
- CAN bus 1.5; 3.27; 3.28; 3.29; 4.37
- CAN bus bit rate 4.33
- CAN bus cable lengths 4.36
- CAN bus connection 4.32
- CAN bus line parameters 4.35
- CAN bus terminators 4.35
- CAN bus wiring 4.34
- CAN-Bus 4.26; 4.32
- Clock frequency 3.9
- Commissioning 2.1
- Concurrence factor 3.15
- Connections of the supply module with Profibus-DP 4.15
- Contouring control 1.10
- Control in- and outputs 4.16; 4.20
- Control inputs 3.6; 3.9
- Control scheme of the axis regulation controller 8.18
- Control voltage (24V) 4.51
- Cooling air 4.2
- Cooling method 3.5
- Cooling type 3.8
- Coupling relay 3.9; 4.58
- Current 3.6
- D.c link circuit 3.6
- D.c link voltage 3.9
- D.c. 4.18
- D.c. link bridge circuits 3.25
- D.c. link bridges 4.18
- D.c. link filter choke 3.6; 3.25; 3.32
- D.c. link short-circuit contactor 4.50
- D.c. link voltage 4.58; 8.6
- DARC system 1.4
- DARCTOOL 1.5; 5.9; 6.1
- Degree of protection 4.2
- Design features of the motors 3.11
- Dimensions 3.4
- Dimensions and connections of the mains filter 8.16
- Dimensions of EMC screw connection 3.33
- Dimensions of housing 3.5
- Dimensions of the axis regulation controller 3.10
- Dimensions of the braking resistors 8.13
- Dimensions of the d.c. link filter choke 8.14
- Dimensions of the motors 8.10
- Dimensions of the supply modules 3.7
- DIP switch S1 4.33
- DIP switch S2 4.37
- Displays on the supply modules and the axis regulation controllers 4.58
- DOWNLOAD 6.3

- Drive dimensioning 4.3
- Earth loops 4.3
- Earthing 4.5; 4.11
- Electronic gearing 1.9
- Electronics supply 3.6; 3.9
- Electrostatic charges 4.3
- EMC aspects for switching ... 4.5
- EMC measures 4.4
- EMC screw connection 3.33
- EMERGENCY OFF 4.44
- Emitted interference 3.5; 3.8
- Enabling LED 4.61
- Enabling LED 8.8
- Encoder cables 3.22; 3.23; 3.24
- Environment temperature 3.5
- Equipment fastening 4.5
- Equipment versions 3
- External enabling signal 4.20
- Fieldbus cable CAN bus 3.27
- Fieldbus cable Profibus-DP 3.27
- Fieldbus connection 1.5
- Fieldbus connection 4.9
- Fieldbus plug Profibus-DP 3.27
- Fieldbus plugs CAN bus 3.28
- Filter 4.10
- Filter measures 4.10
- Fitting 4.1
- Fitting depth 3.4
- Fitting sequence 3.4
- Frequency 3.6
- Gantry axis operation 1.9; 4.53; 4.57; 4.58; 5.3; 5.7
- Holding brake 4.40; 4.41; 4.56
- Humidity stress 3.5; 3.8
- INC distributor 4.23
- INC-distributor 3.30
- INC-distributor cables 3.24
- Incremental encoder cables 3.23
- Incremental position encoder 3.29
- Incremental position encoder interface 4.23
- Input voltage 3.9
- Installation 4.1
- Installation height 3.5; 3.8
- Insulation resistance 3.5; 3.8
- Interference immunity 3.5; 3.8
- Interpolation 1.6
- Latching block 5.5
- Laying of bus cable 4.30; 4.35
- LED messages 8.6
- LED messages with the CAN bus interface 4.60
- LEDs 4.58
- Limit switch 4.50
- Limit switch switching suggestion gantry IIa gantry axes 4.55
- Limit switch switching suggestion gantry IIb.. 4.55
- Line parameters 4.30
- Mains connections 4.1
- Mains filter 3.6; 3.33
- Mains supply lead 4.7
- Mass 3.5; 3.8
- Master encoder interface 1.6
- Measuring points axis regulation controller 4.43
- Measuring points supply module 4.24
- Mechanical design of the DARC system 3.4
- Medium d.c. link power P_{mZ} 3.14
- MOBus 3.28; 3.29
- Module addressing Profibus-DP 4.28
- Module bus cable 3.28
- Module bus connection 4.37
- Module bus interface 3.29
- Module identification 4.13
- Motor cable connection 4.39
- Motor cables 3.17
- Motor connection 4.8
- Motor leads 4.6
- Motor temperature monitoring 3.9
- Motor-axis regulation controller combination 3.11
- motor-axis regulation controller combinations 8.9
- Motors 3.11; 8.10
- Motor-winding short circuit 4.46
- Motor-winding short-circuit 4.51
- Mounting plates 4.5
- Multi-axis drive packages 3.14
- Network supply cable 3.20
- Nominal output current 3.9

- Nominal speed 3.13
- Nominal voltage 3.6
- Norm survey 7.1
- Operating instructions 2.1
- Operating type 3.5; 3.8
- Override potentiometer 1.9; 3.31; 4.25
- Override potentiometer connection 4.26
- Parallel bus cable 3.26
- Parallelbus 4.19
- Parameterizing 5.9
- Peak braking power 3.6
- Performance classes 1.5
- Peripheral equipment 4.40
- Personal safety measures 5.1
- Pin configuration of the CAN bus interface 4.32
- Pin configuration of the Profibus-DP interface 4.27
- Possible versions of the axis regulation controller 1.7
- Power consumption supply module 4.19
- Power contactors 5.5
- Power loss 3.6; 3.9
- Power terminal 4.17
- Power terminals 4.7
- Profibus DP interface baud rate 4.26; 4.28
- Profibus-DP 3.27
 - Fieldbus connection 4.26
- Profibus-DP fieldbus interface 1.5
- Profibus-DP line lengths 4.31
- Profibus-DP line parameters 4.30
- Profibus-DP wiring 4.29
- Prog/User interface 4.37
- Programming the firmware 6.3
- Protection 5.3
- Protection against unintentional start-up 5.4
- Protection type 3.5; 3.8
- Qualified electrician 4.1
- Quick-stop inputs 4.40
- Radio-interference suppression 4.3
- Ready for operation (BTB) 4.20
- Reference input 4.41
- Residual current protection equipment 4.3
- Resolver cables 3.21
- Resolver interface 4.42
- Risk of accident 5.1
- SAE absolute value encoder interface 4.21
- Safety information 1
- Safety instructions 2.1
- Safety measures 5.3
- Safety notices 1.2
- Scheme of the DARC system 8.17
- Screen connection terminals 3.34
- Screen connections 4.5
- Screening 4.10; 4.30; 4.35
- Serial number axis regulation controller 3.3
- Serial number supply module 3.2
- Service interface 1.5; 3.31; 6.1
- Service interface cable 3.26
- Service interface RS232 4.25
- Service interface with override potentiometer connection 4.25
- Setting the bit rate on the SeleCAN bus 4.33
- Single axis operation 1.9
- Slow-releasing timing relay 4.51
- Speed/torque characteristic curve 3.12
- Speed/torque diagram 3.12
- SSI interface 4.21
- Stopping the drives using hardware 4.52; 4.53
- Supply module 1.4; 3.1; 3.5
- Supply module with CAN bus interface (SeleCAN) 4.60
- Suppressor 4.44
- Suppressor diode 4.42; 4.58
- Switching on 5.6
- Switching on for the first time 5.6
- Switching suggestions gantry I and gantry II... 4.49
- Switching suggestions I-III for stopping... 4.47
- Switching suggestions IV for stopping... 4.48

- Switch-on sequence 5.7
Telegram of the SSI interface for multi-turn encoders 4.22
Temperature monitoring 4.40
Temperature sensor 4.4
Terminal connection diagram DARC system 4.12
Terminal X1 4.40
Terminal X10 4.26; 4.32
Terminal X11 4.17
Terminal X12 4.37
Terminal X13 4.37
Terminal X2 4.42
Terminal X20 4.19
Terminal X3 4.43
Terminal X30 4.19
Terminal X4 4.43
Terminal X5 4.39
Terminal X6 4.20
Terminal X7 4.25
Terminal X8 4.21
Terminal X9 4.24
Terminator 3.26; 4.19
the braking resistors 8.13
the d.c. link filter choke 8.14
The DARC system 1.4
the mains filter 8.16
Trigger signal 4.21; 4.41
Type code axis regulation controller 3.2
Type code supply module 3.1
Versions of the supply module 1.6
Vibration resistance 3.5; 3.8
Vibrations 4.2
Voltage drop 4.58
Voltage rise 4.58
Wiring the CAN bus system 4.34