

3. Electrical Characteristic [Conditions for Measuring: Ambient temperature 25°C(77°F)]

Items		Symbol	VZ series	Measured Conditions
Operating Voltage	Min.	V _{dd}	3.0V DC	—
	Max.		6.0V DC	—
Electrical Current Consumption	Avg.	I _w	170 μA	I _{out} =0
	Max.		300 μA	
Output Current	Max.	I _{out}	100 μA	V _{out} ≥ V _{dd} - 0.5
Output Voltage	Min.	V _{out}	V _{dd} - 0.5VDC	—
Circuit Stability Time (When voltage is applied)	Avg.	T _{wu}	—	—
	Max.		30s	

TIMING CHART

1. Digital Output

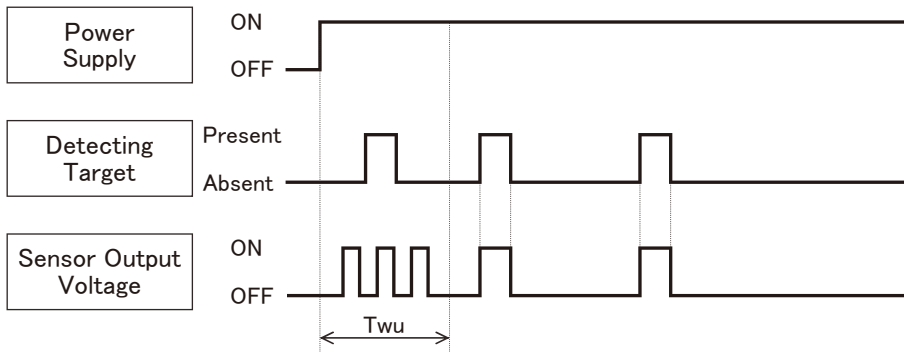

[Durations]

T_{wu} : Circuit Stability Time: About 30s. (Max.)
 During this stage, the output's status is undefined (ON/OFF) and detection is therefore not guaranteed.

DETECTION PERFORMANCE

1) Standard detection type

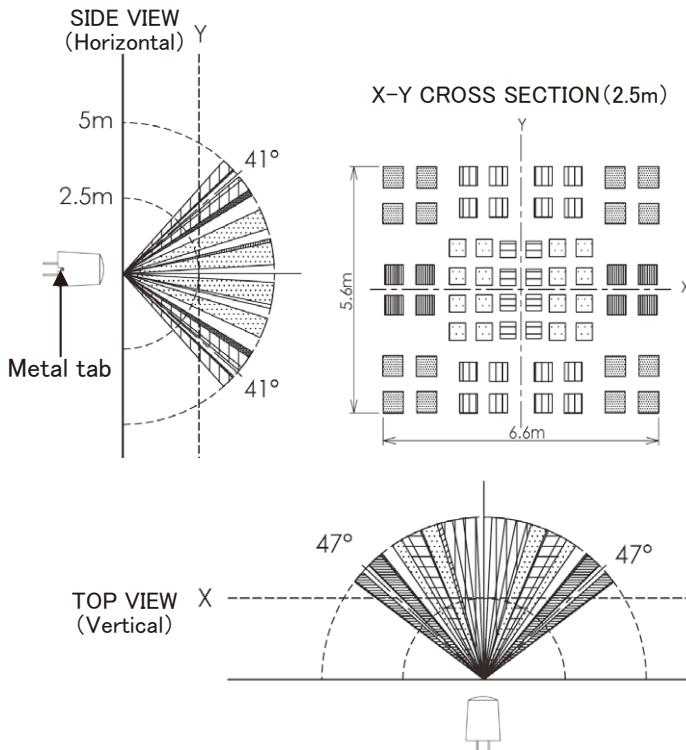

2) Long Distance detection type

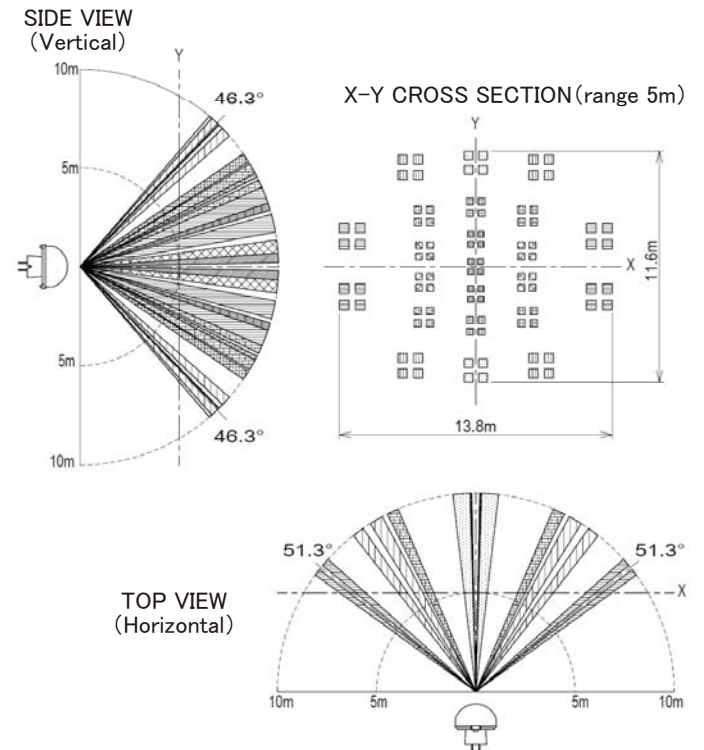

2. Notes Regarding the Detection Zone

As shown on the diagram, the detection zone is polarized.
 If a target enters the detection zones + and - at the same time, the signals are respectively cancelled and detection could become impossible at maximum detection range.
 (Please refer to the detection area diagram for details)

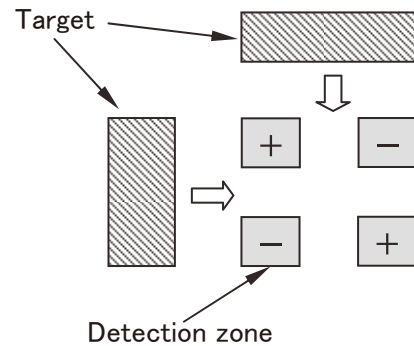

HOW TO USE

1. Wiring Diagram (Digital Output)

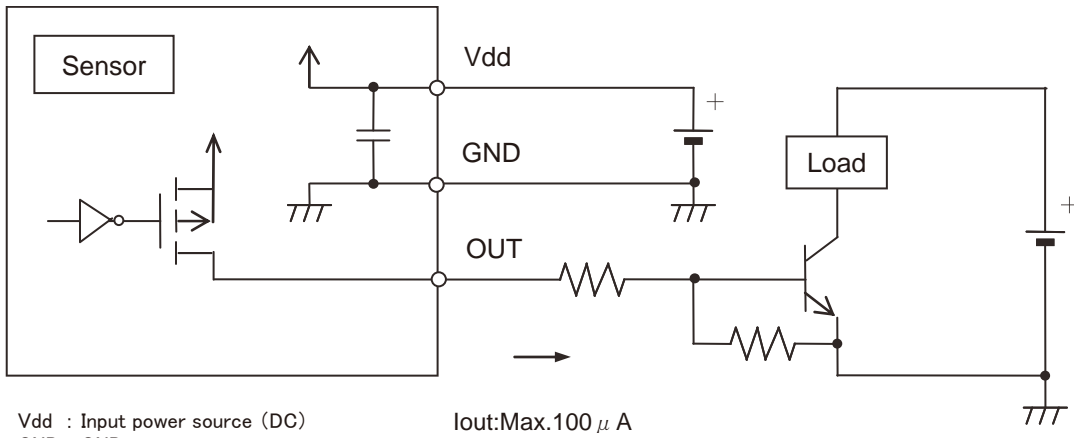

Vdd : Input power source (DC)
 GND : GND
 Out : Output (Comparator)

2. Moving Direction Concept

As detailed on the diagram, please install the sensor so that the expected trespassing direction corresponds to the axis X or axis Y.

In some cases, intrusions that occur parallel to the axis Z in every detection zone, closing toward the sensor, may not be detected.

