

PCA-6653

Video Display Card for
Flat Panel and CRT

Copyright Notice

This document is copyrighted by Advantech Co., Ltd. All rights are reserved. Advantech Co., Ltd., reserves the right to make improvements to the products described in this manual at any time without notice.

No part of this manual may be reproduced, copied, translated, or transmitted in any form or by any means without the prior written permission of Advantech Co., Ltd. Information provided in this manual is intended to be accurate and reliable. However, Advantech Co., Ltd., assumes no responsibility for its use, nor for any infringements upon the rights of third parties which may result from its use.

All brand and product names mentioned herein are trademarks or registered trademarks of their respective holders.

Part No. 2002665300, 1st Edition
Printed in Taiwan, September 1995

Contents

Chapter 1 Introduction	1
Description	2
Specifications	3
Display Support	4
Video BIOS	4
Simultaneous Display Mode	5
Chapter 2 Hardware Setup	7
Hardware Configuration	8
Connectors	10
Jumper Setting	11
Pin Assignments	12
Power Management	13
Chapter 3 Software Drivers and Utilities ...	15
Simultaneous Display Mode	16
Sleep Mode	16
Software Support	17
Driver Installation	18
Windows Setup	19
AutoCAD R12	22
Lotus 1-2-3 and Lotus Symphony	24
VESA	26
Word	27
WordPerfect	28

CHAPTER

1

Introduction

Description

The PCA-6653 is based on the CHIPS VGA flat panel/CRT controller and is fully IBM VGA compatible. This controller offers a large set of extended functions and higher resolutions, and it supports simultaneous functioning. Since the PCA-6653 VGA adapter is fully compatible, you do not require any special drivers to operate in standard modes. The enclosed software drivers allow you to take advantage of the extended features of the PCA-6653:

High performance in Microsoft Windows

Resolutions up to 1024x768 in graphics modes with 256 colors

640x480 resolution in graphics modes with 32K, 64K, and 16M colors

132 column text mode

Warning!



Be sure to turn off the power and unplug all components before attempting to install or adjust the PCA-6653. Make sure the jumpers are set correctly before connecting the PCA-6653 to your flat panel display. Incorrect jumper settings could damage your display.

Specifications

Chipset: CHIPS 65545, integrated flat panel / CRT VGA controller

Slot: High performance 16-bit ISA-bus add-on card

BIOS: 27C010, supports 4 banks, 32KB for each bank

Memory: 1MB DRAM on board

256Kx16 DRAM socket for frame buffer (Optional)

Windows GUI (Graphic User Interface) Accelerator:

32-bit BitBLT Engine

Hardware Cursor

Wait State: 32-bit Memory read/write operation

Zero wait state (when CPU write to 66545)

Simultaneous CRT/LCD display: Available with TFT, STN, B/W, EL, CRT

Display support: CRT - 1024x768 Non-interlaced analog or multi-synch monitors with 256 colors

640x480 CRT and Panel display with 64K colors

Flat panel - TFT LCD (Max resolution is 1024x768)

DSTN /STN LCD (Max resolution is 800x600)

B/W LCD

PLASMA LCD

EL

Connector: DB-44 for Flat panel Display

DB-15 for CRT

Built-in 44-pin for general purpose connector (Pin Header)

Built-in 5-pin for keyboard connection (Housing)

Power: On-board DC-DC converter supplies LCD bias voltage (VEE)

Power Management: Chips 65545 power saving stand-by mode

Driver Support

The software driver provides:

Microsoft Windows 3.XX

MS DOS

AutoCAD Release 12

Lotus 1-2-3

Lotus Symphony

VESA

Microsoft Word

WordPerfect

132 Column Text Mode (only usable in WordPerfect and Wordstar)

The PCA-6653 provides 16.7M colors with a CRT output frequency of 65 MHz.

Video BIOS

The standard BIOS chip supports four kinds of flat panel displays:

TFT LCD: Toshiba LTM09C016

DSTN LCD: Sharp LM64183P

MONO LCD: Sharp LM64C142

EL: Planar EL640.480AD4

Simultaneous Display Mode

The PCA-6653 supports simultaneous display to a CRT monitor and a flat panel display. The flat panel may be TFT, mono, DSTN, or EL.

If you use a DSTN LCD in this mode, the display must be under 16/256 colors or the CRT and flat panel screens will tremble. You must add a frame buffer with 512K RAM and update the BIOS setup. Call us for assistance.

CHAPTER

2

Hardware Setup

Hardware Configuration

The PCA-6653 is based on chipset 65545 and has high performance, a simple configuration, and fully supported LCD/EL/CRT.

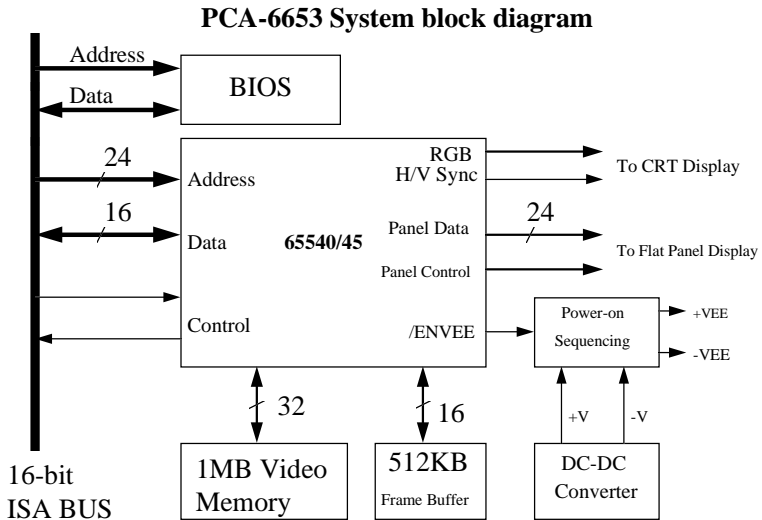

Figure 2-1 Block Diagram

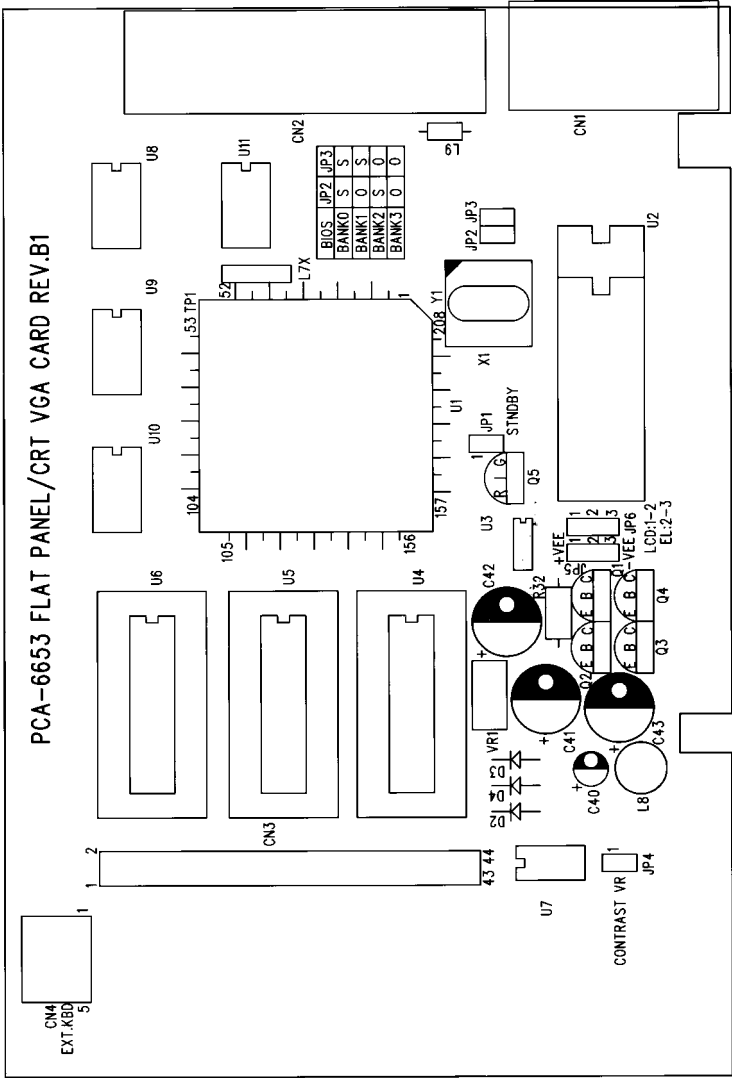

Figure 2-2 Component / Jumper Placement

Connectors

CN1	DB-15 Female for CRT monitor
CN2	DB-44 Female for flat panel display
CN3	pin-header 44-pin for flat panel display (pin to pin compatible with CN2)
CN4	housing 5-pin for keyboard connection

Jumper Setting

Be sure the jumper setting is correct before you install the card to the chassis. Refer to figure 2-2 for pin assignments.

JP1	2 PIN	1: standby mode to save power , 0: normal mode
JP4	2 PIN	External Contrast Adjustment VR connector
JP5	3 PIN	VEE for LCDs power source selection 1-2 : +VEE (output is positive) 2-3 : -VEE (output is negative)
JP6	3 PIN	Panel Colock polarity select (SHFCLK) 1-2 : +SHFCLK (for LCDs) 2-3 : -SHFCLK (for EL)
JP2,JP3	2 PIN	ROM BIOS Bank select

<u>BANK</u>	<u>JP2</u>	<u>JP3</u>	<u>LCD Model</u>
Bank 0	1	1	LTM09C016
Bank 1	0	1	LM64C142
Bank 2	1	0	LM64183P
Bank 3	0	0	EL640.480AD4

VR1: VEE adjustment for LCD/EL

Step 1 - Short the JP4.

Step 2 - Adjust the voltage for each LCD VEE. Voltage ranges from +12V to +40V

Note: The two jumper settings are 0 (open) and 1 (closed).

Warning! Turn off the system power, and disconnect the cables prior to adjusting the voltage!



Adjusting the VR1 may damage the LCD/EL display module. Call if you need assistance.

Pin Assignments

CN1:

<u>Pin No.</u>	<u>Descriptions</u>	<u>Pin No.</u>	<u>Descriptions</u>
1	R	9	(Not used)
2	G	10	Ground
3	B	11	(Not used)
4	(Not used)	12	(Not used)
5	Ground	13	Horizontal sync
6	Ground	14	Vertical sync
7	Ground	15	(Not used)
8	Ground		

CN2 and CN3:

<u>Pin No.</u>	<u>Descriptions</u>	<u>Pin No.</u>	<u>Descriptions</u>
1	+12V	23	P14
2	+12V	24	P15
3	Ground	25	P16
4	Ground	26	P17
5	+5V	27	P18
6	+5V	28	P19
7	VEESAFE	29	P20
8	Ground	30	P21
9	P0	31	P22
10	P1	32	P23
11	P2	33	Ground
12	P3	34	Ground
13	P4	35	ASHFCLK
14	P5	36	FLM
15	P6	37	M
16	P7	38	LP
17	P8	39	Ground
18	P9	40	ENABKL
19	P10	41	KB_DATA
20	P11	42	KB_CLK
21	P12	43	C_VR1
22	P13	44	C_VR2

CN4:

<u>Pin No.</u>	<u>Descriptions</u>
1	Clock
2	Data
3	(Not used)
4	Ground
5	+5V

Power Management

To save power, you can disable the Chips 65545 by setting the JP1 jumper to 1 (closed). This clears the memory and interrupts input and output. You can use the included software if you only want to stop output. To disable the flat panel's backlight, set CN2-pin40 (EN-ABKL) to 0 (open).

CHAPTER

3

***Software Drivers and
Utilities***

This chapter describes the installation and operation of the software drivers on the included Display Driver diskette.

Simultaneous Display Mode

The 65545 VGA BIOS supports monochrome LCD, EL, color TFT and STN LCD flat panel displays. It also supports interlaced and non-interlaced analog monitors (VGA color and VGA monochrome) in high-resolution modes while maintaining complete IBM VGA compatibility. Digital monitors (i.e. MDA, CGA, and EGA) are NOT supported. Multiple frequency (multisync) monitors are supported as analog monitors.

Both CRT and panel displays can be used simultaneously. The PCA-6653 can be set in one of three configurations: on a CRT, on a flat panel display, or on both simultaneously. The system is initially set to simultaneous display mode. In the utility diskette, there are three .COM files which can be used to select the display. Simply type the filename at the DOS prompt:

CT.COM Enables CRT display only

FP.COM Enables panel display only

SM.COM Enables both displays at the same time.

Sleep Mode

The Display Driver diskette contains two files that support sleep mode. Simply type the filename at the DOS prompt:

ON.COM switches to normal display mode.

OFF.COM switches to sleep mode.

Software Support

The drivers support the following applications using the filenames and resolutions listed:

<u>Application</u>	<u>Filename</u>	<u>Resolution</u>	<u>Colors</u>	
Windows 3.1	LINEAR4.DRV	640x480	16	
		800x600	16	
		1024x768	16	
	LINEAR8.DRV	640x480	256	
		800x600	256	
		1024x768	256	
	AutoCAD R12	LINEAR15.DRV	640x480	32K
		LINEAR16.DRV	640x480	64K
		LINEAR24.DRV	640x480	16M
		RCTURBOC.EXP	640x480	16
800x600			16	
1024x768			16	
640x480			256	
800x600			256	
1024x768	256			
640x480	32K			
640x480	64K			
640x480	16M			
Lotus 1-2-3 2.0 and Lotus Symphony 1.0,1.1	V132X25.DRV	132x25 (Text)	16	
	V132X50.DRV	132x50 (Text)	16	
	VESA 1.2	VESA.COM	800x600	16
1024x768		16		
640x400		256		
640x480		256		
800x600		256		
1024x768		256		
640x480		32K		
640x480	64K			
Word 5.0	VGA600.VID	800x600	16	
	VGA768.VID	1024x768	16	
Word 5.5	VGA55600.VID	800x600	16	
	VGA55768.VID	1024x768	16	

WordPerfect 5.0	CHIPS600.WPD	800x600	16
	CHIPS768.WPD	1024x768	16
WordPerfect 5.1	VGA600.VRS	800x600	16
	VGA768.VRS	1024x768	16

Driver Installation

Necessary prerequisites

The instructions in this manual assume that you understand elementary concepts of MS-DOS and the IBM Personal Computer. Before you attempt to install any driver or utility you should: know how to copy files from a floppy disk to a directory on the hard disk, understand the MS-DOS directory structure, and know how to format a floppy disk. If you are uncertain about any of these concepts, please refer to the DOS or Windows user reference guides for more information before you proceed with the installation.

Before you begin

Before you begin installing software drivers, you should make a backup copy of the Display Driver diskette, and store the original in a safe place. The Display Driver diskette contains drivers for several versions of certain applications. You must install the correct version in order for the driver to work properly so make sure you know which version of the application you have.

Windows Setup

These drivers are designed to work with Microsoft Windows 3.1. You may install these drivers through Windows or in DOS.

Step 1: Install Windows as you normally would for a VGA display. Run Windows to make sure that it is working correctly.

Step 2: Place the Display Driver diskette in drive A. In Windows Program Manager, choose **File** from the Options Menu. Then from the pull-down menu, choose **Run . . .**. At the command line prompt, type **A:\WINSETUP**. Press the <ENTER> key or click **OK** to begin the installation. At this point the setup program locates the directory where Windows is installed. For proper operation, the drivers must be installed in the Windows subdirectory. Press <ENTER> to complete the installation. Once completed, the Display Driver Control Panel appears on the screen. This Control Panel allows you to select and load the installed drivers.

Another method of installing these drivers is through the File Manager. Click on **Drive A:**. Then double-click on **WINSETUP.EXE** to begin installation.

Changing Display Drivers in Windows

To change display drivers in Windows, select the **Windows Setup** icon from the Main window. You will be shown the current setup configuration. Select **Change System Settings** from the Option menu. Click on the arrow at the end of the Display line. You will be shown a list of display drivers. Click on the driver you want. Then click on the **OK** button. Follow the directions to complete the setup.

Changing Color Schemes

After you change display drivers, you may notice that the color scheme used by Windows looks strange. This is because different drivers have different default colors. To change the color scheme, select the **Control Panel** from the Main window. Select the **Color** icon. You will be shown the current color scheme. Choose a new color scheme and click the **OK** button.

DOS Setup

Step 1: Install Windows as you normally would for a VGA display. Run Windows to make sure that it is working correctly. Then exit Windows.

Step 2: Place the Display Driver diskette in drive A. Type **A:** <ENTER> to make this the default drive. Type **SETUP** <ENTER> to run the driver SETUP program. Press any key to get to the applications list. Using the arrow keys, select **Windows Version 3.1** and press the <ENTER> key. Press the <ENTER> key to select **All Resolutions**, and then press <END> to begin the installation. At this point you will be asked for the path to your Windows System directory (default C:\WINDOWS). When the installation is complete, press any key to continue. Press <ESC> followed by Y to exit to DOS.

Step 3: Change to the directory where you installed Windows (usually C:\WINDOWS).

Step 4: Type **SETUP** <ENTER> to run the Windows Setup program. It will show the current Windows configuration. Use the up arrow key to move to the Display line and press <ENTER>. A list of display drivers will be shown. Use the arrow keys to select one of the drivers starting with an asterisk (*) and press <ENTER>.

Step 5: Follow the directions on the screen to complete the setup. In most cases, you may press <ENTER> to accept the suggested option. When Setup is done, it will return to DOS. Type **WIN** <ENTER> to start Windows with the new display driver.

Changing Display Drivers in DOS

To change display drivers from DOS, change to the Windows directory and run Setup, repeating steps 4 and 5 from the previous page. Besides the special display drivers marked by an asterisk (*), you should be able to use the following standard drivers:

VGA	640x480, 16 colors
Super VGA	800x600, 16 colors

Panning Drivers

Special panning drivers are provided to allow high-resolution modes to be displayed on a flat panel or CRT. These drivers will show a section of a larger screen and will automatically pan, or scroll, the screen horizontally and vertically when the mouse reaches the edge of the display.

Linear Acceleration Drivers

A special high-performance linear acceleration driver is provided for 256-color modes. This driver may require special hardware and may not be supported on all systems. It is only available for Windows3.1.

AutoCAD R12

These drivers are designed to work with Autodesk AutoCAD R12. They conform to the Autodesk Device Interface (ADI) for Rendering drivers and Display drivers. These display list drivers accelerate redraw, pan, and zoom functions.

Driver installation

Step 1: Place the Display Driver diskette in drive A. Type **A:** <ENTER> to make this the default drive. Type **SETUP** <ENTER> to run the SETUP program. Press any key to get to the applications list. Using the arrow keys, select ***AutoCAD Release 12*** and press <ENTER>. This will display a list of supported driver resolutions. Using the arrow keys and the <ENTER> key, select the resolutions that are appropriate for your monitor. When all of the desired resolutions have been selected, press <END> to begin the installation. At this point you will be asked for a drive and directory to copy the driver files. Enter the drive and directory that contains the installed AutoCAD R12. If the destination directory does not exist you will be asked for confirmation. When the installation is complete, press any key to continue. Press <ESC> followed by Y to exit to DOS.

Step 2: Go to the AutoCAD directory where the new drivers were installed and run the driver installation program by typing **ACAD12 - r** <ENTER>. This program will configure your AutoCAD R12 to use the new display drivers. Select ***TurboDLD Classic***.

Configuring TurboDLD

Select ***Configure Video Display***. In Display Device Configuration choose ***Select Graphics Board/Resolution***. Then choose ***Select Display Graphics Board***. After choosing a graphics board, go to ***Select Display Resolution***. After selecting the display resolution, save the new configuration, and return to the main menu.

Basic Configuration Menu

This menu allows you to modify:

Number of AutoCAD Command Lines

Font Size	6x8/8x8/8x14/8x16/12x20/12x24
Dual Screen	Enable/Disable
User Interface Configuration	
Double Click Interval Time	
BP Button	
BP Highlight	Patt Line/Xor Rect/Both
BP Refresh	Enable/Disable
BP Cache	Enable/Disable

Expert Configuration Menu

This menu allows you to modify:

Display List	Enable/Disable
Drawing Cache	Enable/Disable
Use Acad 31 bit space?	Yes/No
Internal Command Echo	Enable/Disable
BP Zoom Mode	Freeze/Float
Regen Mode	Incremental/Fast

If your previously installed driver is not TurboDLL, you will have to reconfigure the RENDER command the first time you use it.

Lotus 1-2-3 and Lotus Symphony

These drivers are designed to work with Lotus 1-2-3 versions 2.0, 2.01 and 2.2, and with Lotus Symphony versions 1.0 and 1.1.

Driver installation

Step 1: Place the Display Driver diskette into drive A. Make A the default drive by typing **A:** <ENTER>. Run the SETUP program by typing **SETUP** <ENTER>. Press any key to display a list of supported applications. Use the arrow keys to select **Lotus/Symphony**, and press <ENTER>. A list of supported screen resolutions will be displayed. Use the arrow keys to select the desired screen resolution and press <ENTER>. (Make sure your monitor is able to display the resolution desired) Press <END> to begin the driver installation process. A default drive and directory path will be displayed. Use the backspace key to erase this default and type in the 123 directory. At this point you may be asked to create the target directory if it does not already exist. After the files have been installed, press any key to return to the list of supported applications. Press <ESC> followed by Y to exit to DOS. Copy all the files that were just created in the temporary directory onto a formatted floppy diskette.

Step 2: Go to your 123 directory, and start the installation program. Type the following commands:

C: <ENTER>

INSTALL <ENTER>

Step 3: The Lotus installation program will load and present the installation menu. From this menu, select **Advanced Options**. From the Advanced Options menu, select **Add New Drivers To Library**. From the Add New Drivers Menu, select **Modify Current Driver Set**. From the Modify Driver Set Menu, select **Text Display**. From the Text Display menu, select one of drivers.

Step 4: After the selection of the appropriate VGA display driver, you will need to exit this menu and return to the Main Lotus Installation Menu. Do this by selecting **Return To Menu**.

Step 5: At the Main Lotus Installation Menu, select **Save Changes**.

Step 6: At this point the Installation Menu will prompt you for the name of your new Lotus configuration file. The Lotus system will prompt you with the default value — 123.SET, but you may want to use a filename that indicates the resolution of its driver. For example, if you installed the 132 column by 25 line driver, you could name this driver 132X25.SET, or if you installed the 80 by 50 driver, you may want to call the file 80X50.SET.

Step 7: The installation of your Lotus 1-2-3 driver is now complete. You will need to exit the Lotus installation program at this point. At the main Lotus Installation Menu, select *Exit*.

NOTE: If your driver set is not 123.SET, you have to type the filename of your driver set in the command line when you start Lotus 1-2-3. For example, if you named your driver set 132X25.SET, type the following to start Lotus 1-2-3:

123 132X25.SET <ENTER>

VESA

The Video Electronics Standards Association (VESA) has created a standard for a Super VGA BIOS Extension (VBE). This defines a standard software interface to allow application programs to set and control extended video modes, such as 800x600 graphics, on video adapters from different manufacturers.

The VESA driver adds this Super VGA BIOS Extension to the VGA BIOS. Any application program which supports the VESA standard driver interface can be used with this driver. This VESA driver conforms to the VESA Super VGA Standard #VS891001.

Driver installation

Step 1: Place the Display Driver diskette into drive A. Make A the default drive by typing **A:** <ENTER>. Run the SETUP program by typing **SETUP** <ENTER>. Press any key to display a list of supported applications. Use the arrow keys to select VESA Driver *Version 1.2* and press <ENTER>. Press the <ENTER> key to select *All Resolutions*, and press <END> to begin the installation. A default drive and directory path will be displayed. Use the backspace key to erase this and type in a directory that is in the directory path (such as C:\BIN or C:\UTILS). After the files have been installed, press any key to return to the list of supported applications. Press <ESC> followed by Y to exit to DOS.

Step 2: To install the VESA driver, type either **VESA** <ENTER> or **VESA +** <ENTER> at the DOS prompt. The optional + command line parameter enables all of the available modes. Make sure that your monitor is capable of displaying these high resolution modes before enabling them.

NOTE: If the video BIOS already supports VBE extended video modes, DO NOT use this driver. Run the VTEST.EXE program to see if the video BIOS supports the VBE modes.

Word

These drivers are designed to work with Microsoft Word 5.0 and 5.5.

Driver installation

If you have already installed Word on your computer, go to Step 2 to install the new video driver.

Step 1: Install Word as normal.

Step 2: After you complete the Word installation, place the Display Driver diskette into drive A. Make A the default drive by typing **A:** <ENTER>. Run the SETUP program by typing **SETUP** <ENTER>. Press any key to display a list of supported applications. Use the arrow keys to select **Word** and press <ENTER>. Use the arrow keys to select the desired screen resolution and press <ENTER> (make sure your monitor is able to display the resolution desired). Press <END> to begin the driver installation process. A default drive and directory path will be displayed. Use the backspace key to erase this and type in your Word directory. After the files have been installed, press any key to return to the list of supported applications. Press <ESC> followed by Y to exit to DOS.

Step 3: Copy the driver file for the desired resolution that was just installed to SCREEN.VID. (The driver file names are listed on pages 12-13.)

WordPerfect

These drivers are designed to work with WordPerfect 5.0 or 5.1. They support 132-column display in editing mode, and high-resolution graphics display in PreView mode.

Driver installation

Step 1: Place the Display Driver Diskette into drive A. Make A the default drive by typing **A:** <ENTER>. Run the SETUP program by typing **SETUP** <ENTER>. Press any key to display a list of supported applications. Use the arrow keys to select **WordPerfect** and press <ENTER>. A list of supported screen resolutions will be displayed. Use the arrow keys to select the desired screen resolution and press <ENTER> (make sure your monitor is able to display the resolution desired). Press <END> to begin the driver installation process. A default drive and directory path will be displayed. Use the backspace key to erase this default and type in the WordPerfect directory. At this point you may be asked to create the target directory if it does not already exist. After the files have been installed, press any key to return to the list of supported applications. Press <ESC> followed by Y to exit to DOS.

Step 2: Start WordPerfect, and press <SHIFT>+<F1> to enter the setup menu. Select **D** for Display and **G** for Graphics Screen Type, and then choose the desired Chips VGA resolution.

Configuring WordPerfect 5.0 for 132 columns

Follow these instructions to configure WordPerfect 5.0 for 132 column text mode:

Step 1: To use the SETCOL program to set 132 columns and 25 rows, type the following command:

SETCOL 132, 25 <ENTER>

Step 2: Start WordPerfect. The program will detect the number of rows and columns automatically. If for some reason WordPerfect is unable to adapt to 132 columns by 25 rows, start WordPerfect with the following command:

WP /SS=25,132 <ENTER>

Configuring WordPerfect 5.1 for 132 columns

Start WordPerfect and press <SHIFT>+<F1> to enter the setup menu. Select **D** for Display and **T** for Text Screen Type and then select *Chips 132 Column Text*.

