

SIEMENS

SIMOREG K 6RA23

Instruction Manual

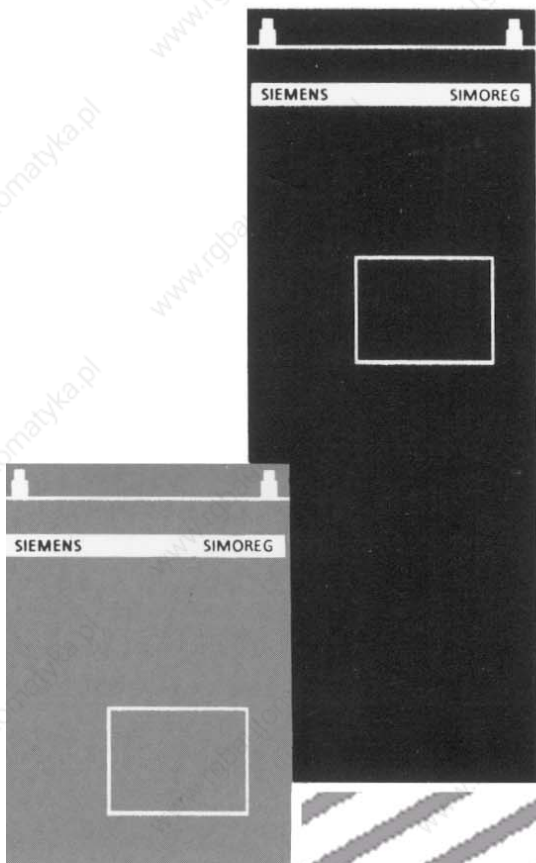

SIEMENS

SIMOREG K

**6RA23 converters with microprocessor,
from 6.3kW to 360kW in a B6C fully-controlled
three-phase bridge circuit and
circulating current-free, anti-parallel circuit
(B6)A(B6)C for DC variable-speed drives**

Instruction Manual

Order No.: 6RX1230-0AD76

Converter software release 4.00

November 1994 Edition

IMPORTANT INFORMATION

This Instruction Manual includes information regarding the mode of operation of the converter using software release 4.00. Although this Instruction Manual can be generally used for all previous software releases, specific parameter code and fault code definitions in these instructions, under certain circumstances, go beyond the information in previous software releases or are contrary to these.

This Instruction Manual does not claim to cover all equipment details and versions or to take into account every conceivable situation regarding the installation, operation or maintenance of the equipment. If additional information is required or if special problems occur, which are not handled in enough detail in these instructions, please contact the local Siemens representative.

NOTE

The contents of this Instruction Manual does not change any previous or existing contract, agreement, or contractual liability. All of the responsibilities of the Siemens ASI 1 Drive Technology Group are specified in detail in the purchase contract which exclusively specifies all of the warranty conditions. This contractual warranty agreement is neither expanded nor restricted by the information contained in this Instruction Manual.

This publication was produced on the Siemens 5822 Office System

Subject to change without prior notice.

The reproduction, transmission or use of this document or contents is not permitted without express written authority. Offenders will be liable for damages. All rights, including rights created by patent grant or registration of a utility model or design, are reserved.

© Siemens AG 1993

Contents

	Page
1. Safety information	1 / 1
2. Type spectrum	2 / 1
2.1 Converter Order No. code	2 / 4
3. Description	3 / 1
3.1 Applications	3 / 1
3.2 Design	3 / 1
3.3 Mode of operation	3 / 1
3.4 Technical data	3 / 2
3.5 Applicable standards	3 / 7
4. Unpacking	4 / 1
5. Installation	5 / 1
5.1 Dimension drawings	5 / 2
5.2 Position of PC boards, ribbon cables, control cables and terminal strips	5 / 8
5.3 Location of the EPROM and mounting options	5 / 10
5.3.1 Location of the EPROMs	5 / 10
5.3.2 Mounting of the option boards Z11 (Order No.: 6RX1230-0AK01), Z14 (Order No.: 6RX1230-0AK05)	5 / 11
5.3.3 Interface expansion (Order No.: 6RX1240-0AL01)	5 / 12
6. Connecting-up	6 / 1
6.1 Instructions for connecting screened control cables	6 / 2
6.2 Block diagrams with recommended connection	6 / 4
6.3 Power connections	6 / 6
6.4 Field supply	6 / 11
6.5 Load resistors	6 / 12
6.6 Fuses and commutating reactors	6 / 14
6.6.1 Commutating reactors	6 / 14
6.6.2 Fuses	6 / 14
6.7 Terminal connecting diagram	6 / 16
6.7.1 Settings	6 / 18
6.8 Terminal assignment	6 / 20

	Page
7. Start-up	7/ 1
7.1 General safety information for start-up	7/ 1
7.2 Operator control panel	7/ 3
7.3 Procedure when parameterizing	7/ 3
7.4 Reset to default values	7/ 6
7.5 Start-up steps	7/ 7
7.6 Start-up with external field converter (field-weakening mode)	7/ 15
7.6.1 Information for operation with an uncontrolled field supply	7/ 15
7.6.2 Start-up with an external field converter (field weakening)	7/ 16
7.6.2.1 Setting the field controller in the external field converter	7/ 15
7.6.2.2 Automatic field characteristic plot	7/ 16
7.7 Manual optimization and manual field characteristic plot	7/ 18
7.7.1 Manual optimization of the current controller and pre-control	7/ 18
7.7.1.1 Pre-control adjustments	7/ 18
7.7.1.2 Current controller adjustments	7/ 19
7.7.2 Manual speed controller optimization	7/ 20
7.7.3 Manual optimization of the EMF controller	7/ 20
7.7.4 Manual field characteristic plot	7/ 21
8. Operation	8/ 1
8.1 Operating statuses, parameter P00	8/ 1
8.2 Fault messages	8/ 3
8.2.1 Acknowledging fault messages	8/ 3
8.2.2 List of fault messages	8/ 4
9. Parameter list	9/ 1
9.1 Parameter overview	9/ 1
9.2 Parameter description	9/ 7
10. Functions	10/ 1
10.1 Function diagrams	10/ 1
10.2 Binary input functions	10/ 13
10.2.1 Inching 1, Crawl	10/ 13
10.2.2 Inching 2, Crawl	10/ 13
10.2.3 Reserved for use later	10/ 14
10.2.4 Enable ramp-function generator	10/ 14
10.2.5 Stop ramp-function generator	10/ 14

	Page	
10.2.6	OFF	10/ 14
10.2.7	Fast stop	10/ 15
10.2.8	Current limit changeover	10/ 15
10.2.9	Reserved for use later	10/ 15
10.2.10	Reset fault memory	10/ 15
10.2.11	Master/slave changeover	10/ 15
10.2.12	Reserved for use later	10/ 16
10.2.13	Reserved for use later	10/ 16
10.2.14	Reserved for use later	10/ 16
10.2.15	External fault	10/ 16
10.2.16	Fixed setpoint 1	10/ 17
10.2.17	Fixed setpoint 2	10/ 17
10.2.18	Additive setpoint 1 at the ramp-function generator input	10/ 17
10.2.19	Additive setpoint 2 at the ramp-function generator input	10/ 17
10.2.20	Additive setpoint 1 at the speed controller input	10/ 17
10.2.21	Additive setpoint 2 at the speed controller input	10/ 17
10.2.22	Ramp-function generator changeover	10/ 18
10.2.23	Droop	10/ 18
10.2.24	Gearbox stage 2	10/ 18
10.2.25	Setpoint reduction	10/ 18
10.2.26	Invert setpoint polarity (from SW 4.0)	10/ 19
10.3	Adjusting current limits	10/ 19
10.4	Speed-dependent current limiting	10/ 19
10.5	DC motor thermal overload protection (I ² t monitoring)	10/ 20
10.6	Standstill monitoring via the binary select output (terminal 46)	10/ 22
10.7	Reduced gearbox stressing	10/ 22
10.8	Anti-stall protection	10/ 22
10.9	Ramp-function generator	10/ 22
10.10	Closed-loop torque control	10/ 23
10.11	Changeover from closed-loop speed- to closed-loop current control	10/ 25
10.12	Operation on weak supply networks	10/ 25
10.13	Disabling monitoring functions / suppressing fault messages	10/ 25
10.14	Selecting the speed actual value	10/ 27
10.14.1	Operation with analog tachometer	10/ 27
10.14.2	Operation with pulse encoder	10/ 27
10.14.3	Operation without tachometer (closed-loop EMF control)	10/ 28

	Page	
10.15	Serial interface	10 / 30
10.15.1	Parameter list output	10 / 30
10.15.2	Read-in parameters	10 / 33
10.15.3	Connector assignments and connecting cables	10 / 35
10.16	External electronics power supply back-up (Faston connectors P24', N24', M)	10 / 39
10.17	Recommended connections for external field supply converters	10 / 39
10.17.1	Recommended circuit configuration for an external field supply converter, SIEMENS MINIREG F10	10 / 39
10.17.2	Recommended circuit configuration for an external field supply converter, SIEMENS MINIREG F33	10 / 39
10.18	Digital interfaces	10 / 42
10.18.1	USS protocol	10 / 42
10.18.1.1	Telegram structure	10 / 44
10.18.1.1.1	Net data block - PKW area	10 / 45
10.18.1.1.2	Net data block - PZD area	10 / 48
10.18.1.1.3	Address byte (ADR)	10 / 52
10.18.1.2	Start-up	10 / 53
10.18.2	Dual port RAM interface	10 / 54
10.19	Motorized potentiometer	10 / 55
11.	Maintenance	11 / 1
11.1	Procedure when replacing software	11 / 2
12.	Service	12 / 1
13.	Spare parts	13 / 1
14.	Appendix	14 / 1
14.1	Additional documentation	14 / 1

	Page
15. SIMOVIS for 6RA23	
15.1 What can SIMOVIS do?	15/ 1
15.2 Commissioning SIMOVIS	15/ 1
15.2.1 System requirements	15/ 1
15.2.2 Transferring software onto the hard disk	15/ 2
15.2.3 Establishing the connection between the PC and 6RA23	15/ 2
15.2.4 Starting SIMOVIS	15/ 3
15.2.5 Mouse replacement	15/ 4
15.2.6 Slave configuration	15/ 4
15.3 Operator control	15/ 5
15.3.1 Special masks	15/ 6
15.3.2 Toggling between online/offline	15/ 7
15.4 Overview of the available masks	15/ 8
15.5 Troubleshooting	15/ 10
16. Installation instructions for EMC-correct installation of Drives	
16.1 EMC basics	16 / 1
16.1.1 What is EMC	16 / 2
16.1.2 Noise radiation and noise immunity	16 / 2
16.1.3 Maximum values	16 / 2
16.1.4 SIMOREG K converters in industrial applications	16 / 2
16.1.5 Non-grounded supplies	16 / 3
16.1.6 EMC planning	16 / 3
16.2 EMC-correct installation/mounting of converters (installation instructions)	16 / 4
16.2.1 General information	16 / 4
16.2.2 Rules for EMC-correct installation	16 / 4
16.2.3 Converter component arrangement	16 / 13
16.2.4 List of the recommended radio interference suppression filters	16 / 14
• 16.3 Information on line-side harmonics generated by converters in a fully-controlled three-phase bridge circuit configuration	16 / 15

1. Safety information



WARNING

This electrical equipment has hazardous voltages and dangerous rotating components when operational.



Non-observance of the safety instructions can result in severe personal injury or property damage.

Only qualified personnel should work on or around the equipment after first becoming thoroughly familiar with all warning and safety notices and maintenance procedures contained herein.

The successful and safe operation of this equipment is dependent on proper handling, installation, operation and maintenance.

Definitions:

QUALIFIED PERSONNEL

For the purpose of this Instruction Manual and product labels, a "Qualified person" is someone who is familiar with the installation, construction and operation of the equipment and the hazards involved. He or she must have the following qualifications:

1. Trained and authorized to energize, de-energize, clear, ground and tag circuits and equipment in accordance with established safety procedures.
2. Trained in the proper care and use of protective equipment in accordance with established safety procedures.
3. Trained in rendering first aid

DANGER

For the purpose of this Instruction Manual and product labels, "Danger" indicates death, severe personal injury or substantial property damage will result if proper precautions are not taken.

WARNING

For the purpose of this Instruction Manual and product labels, "Warning" indicates death, severe personal injury or substantial property damage can result if proper precautions are not taken.

CAUTION

For the purpose of this Instruction Manual and product labels, "Caution" indicates minor personal injury or property damage can result if proper precautions are not taken.

NOTE

For the purpose of this Instruction Manual, "Note" indicates information about the product or the respective part of the Instruction Manual which is essential to highlight.



DANGER

Converters contain hazardous electrical voltages. Death, severe bodily injury or significant material damage will occur if the safety measures are not followed.

1. Only qualified personnel, who are knowledgeable about the converters and the information provided, can install, start-up, operate, troubleshoot or repair the converters.
2. The converters must be installed in accordance with all relevant safety regulations (e.g. DIN VDE) as well as all other national or local regulations. Operational safety and reliability must be ensured by correct grounding, cable dimensioning and appropriate short-circuit protection.
3. All panels and doors must be kept closed during normal operation.
4. Before carrying out visual checks and maintenance work ensure that the AC power supply is disconnected and locked-out. Before the AC supply is disconnected, both converters and motors have hazardous voltage levels. Even when the converter contactor is open, hazardous voltages are still present.
5. When making measurements with the power supply switched-on, under no circumstances should electrical connections be touched. Remove all jewelry from wrists and fingers. Ensure that the test equipment is in good condition and is operationally safe.
6. When working on units which are switched-on, stand on an insulating surface, i.e. ensure that you are not grounded.
7. Carefully follow the relevant instructions and observe all danger-, warning- and cautionary notes.
8. This does not represent a full listing of all the measures necessary for safe operation of the equipment. If you require other information or if certain problems occur which are not handled in enough detail in the information provided in the Instruction Manual, please contact your local Siemens office.



2. Type spectrum

Converter Order No.	Type designation
6RA2318 - 6DS21 - 0	D485 / 30 Mre - GeE6S21
6RA2325 - 6DS21 - 0	D485 / 60 Mre - GeE6S21
6RA2328 - 6DS21 - 0	D485 / 90 Mre - GeE6S21
6RA2331 - 6DS21 - 0	D485 / 125 Mre - GeE6S21
6RA2318 - 6GS21 - 0	D600 / 30 Mre - GeE6S21
6RA2325 - 6GS21 - 0	D600 / 60 Mre - GeE6S21
6RA2328 - 6GS21 - 0	D600 / 90 Mre - GeE6S21
6RA2331 - 6GS21 - 0	D600 / 125 Mre - GeE6S21
6RA2313 - 6DV61 - 0	D420 / 15Mreq - GeG6V61
6RA2318 - 6DV61 - 0	D420 / 30 Mreq - GeG6V61
6RA2325 - 6DV61 - 0	D420 / 60 Mreq - GeG6V61
6RA2330 - 6DV61 - 0	D420 / 100 Mreq - GeG6V61
6RA2332 - 6DV61 - 0	D420 / 140 Mreq - GeG6V61
6RA2318 - 6GV61 - 0	D520 / 30 Mreq - GeG6V61
6RA2325 - 6GV61 - 0	D520 / 60 Mreq - GeG6V61
6RA2330 - 6GV61 - 0	D520 / 100 Mreq - GeG6V61
6RA2332 - 6GV61 - 0	D520 / 140 Mreq - GeG6V61

Rated DC
voltage

Rated current

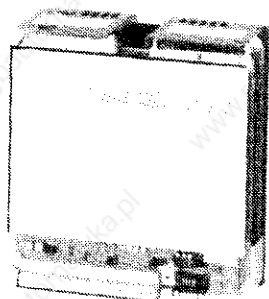

15A Converter

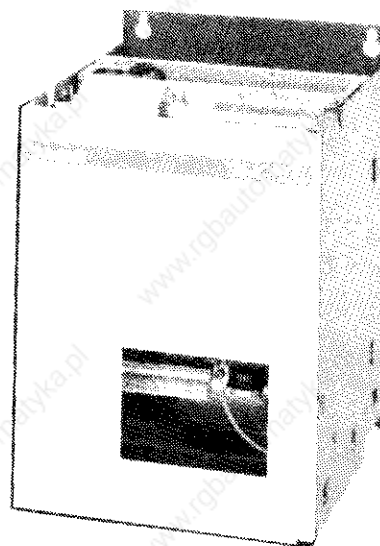

Converter 30 to 140A
without fan

Converter Order No.	Type designation
6RA2375 - 6DS21 - 0	D485 / 200 Mre - GeEF6S21
6RA2377 - 6DS21 - 0	D485 / 250 Mre - GeEF6S21
6RA2381 - 6DS21 - 0	D485 / 400 Mre - GeEF6S21
6RA2385 - 6DS21 - 0	D485 / 600 Mre - GeEF6S21
6RA2375 - 6GS21 - 0	D600 / 200 Mre - GeEF6S21
6RA2377 - 6GS21 - 0	D600 / 250 Mre - GeEF6S21
6RA2381 - 6GS21 - 0	D600 / 400 Mre - GeEF6S21
6RA2385 - 6GS21 - 0	D600 / 600 Mre - GeEF6S21
6RA2375 - 6DV61 - 0	D420 / 200 Mreq - GeGF6V61
6RA2377 - 6DV61 - 0	D420 / 250 Mreq - GeGF6V61
6RA2381 - 6DV61 - 0	D420 / 400 Mreq - GeGF6V61
6RA2385 - 6DV61 - 0	D420 / 600 Mreq - GeGF6V61
6RA2375 - 6GV61 - 0	D520 / 200 Mreq - GeGF6V61
6RA2377 - 6GV61 - 0	D520 / 250 Mreq - GeGF6V61
6RA2381 - 6GV61 - 0	D520 / 400 Mreq - GeGF6V61
6RA2385 - 6GV61 - 0	D520 / 600 Mreq - GeGF6V61

Rated DC
voltage

Rated current

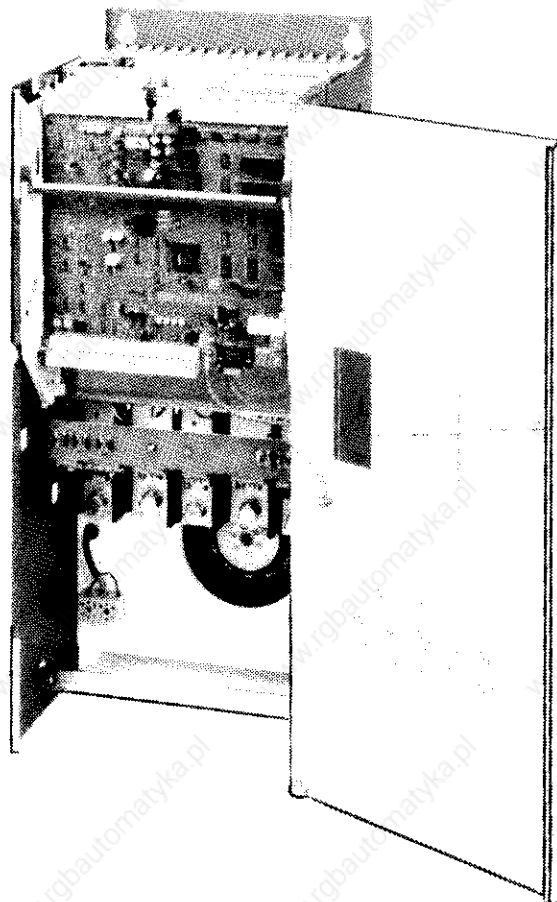

Converter 200 to 600A
with fan

2.1 Converter Order No. code

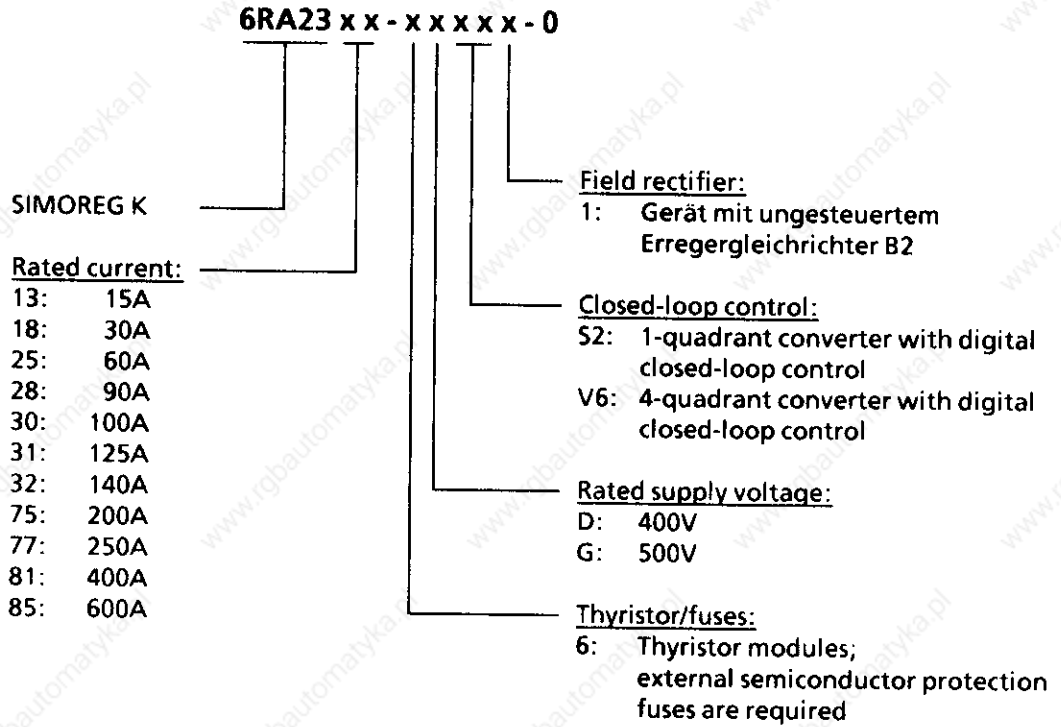

3. Description

3.1 Applications

6RA23 SIMOREG K converters are fully-digital compact converters for connection to a three-phase line to provide armature and field supplies for DC variable-speed drives with rated currents from 15A to 600 A.

There are converters for both single-quadrant and four-quadrant operation, depending on the particular application.

3.2 Design

SIMOREG K converters are extremely compact. The 15A units can either be mounted flat on the mounting panel in the cubicle, on end to save space, or mounted in withdrawable racks. The modular mechanical design of the 30A to 600A converters makes them easy to service due to good accessibility to individual components. The electronics box accommodates the basic electronics as well as any supplementary boards, and can be easily swung-out or removed.

External signals (binary inputs/outputs, analog inputs/outputs, pulse encoder, etc.) are connected to the basic electronics board.

Two analog inputs, three analog outputs, four binary inputs and one binary output are available.

SIMOREG converters can be parameterized using the three keys and three 7-segment displays on the simple operator control panel on the electronics board. The converter can also be parameterized using the RS 232 interface on the electronics board with a conventional PC and suitable software. This PC interface is used for start-up, maintenance/service when shutdown, or for troubleshooting during operation, and is thus a service interface.

For single-quadrant converters, the armature is supplied using a fully-controlled three-bridge, and for four quadrant converters, using two fully-controlled three-phase bridges in a circulating-current free, anti-parallel circuit configuration.

For converters with 15 A rated current, the power section, including gating is mounted on a PC board.

For converters with rated currents 15 A to 600 A, the power section for armature and field uses isolated thyristor modules, and thus the heatsink is electrically isolated. The housing and terminal covers of the power connections provide protection against accidental contact when working in the vicinity of the converters. All connecting terminals are accessible from the front.

The field is supplied from an uncontrolled single-phase bridge rectifier.

3.3 Mode of operation

All open-loop and closed-loop drive control functions and communications are realized by a powerful 16-bit microprocessor.

3.4 Technical data

30A to 600A converters, 3-ph. AC 400V / 1Q

Order No.	6RA23... - 6DS21							
	18	25	28	31	75	77	81	85
Rated voltage/ output V	3-ph. 400 (+ 15% / - 20%) 1)							
Rated supply voltage, electronics power supply V	3-ph. 400 (+ 15% / - 20%); $I_n = 60\text{mA}$;							
Rated supply voltage fan V					3-ph. 400 ($\pm 15\%$); 0,18A, 90Watt Air flow: 570m ³ /h Fan noise: 63dBA			
Rated supply voltage, field V	2-ph. max.400 (+ 15%)							
Rated frequency Hz	Converters automatically adapt themselves to the frequency of the available supply voltage in the range from 45 to 65 Hz							
Rated DC voltage V	485							
Rated DC current A	30	60	90	125	200	250	400	600
Rated output kW	15	29	44	61	97	121	194	291
Power loss at rated current (approx.) W	140	230	320	440	650	800	1250	1850
Rated DC voltage, field V	340							
Rated DC current, field A	5	10			15		25	
Operational ambient temperature °C	0 to 45 at I_{rated} self-ventilated 3)				0 to 35 at I_{rated} forced-cooled 3)			
Storage and transport temperature °C	- 30 to + 85							
Installation altitude above sea level	≤ 1000 m at rated DC current 4)							
Control stability	$\Delta n = 0.1\%$ with analog tachometer 2) $\Delta n = 0.006\%$ with digital tachometer and digital setpoint 2)							
Humidity classification DIN 40040 SN 26556	F							
Deg. of prot. DIN 40050 IEC 144	IP 00							
Dimensions	refer to dimension drawings							
Weight (approx.) kg	11	14	14	16	23	23	31	31

Explanation of the footnotes after the tables

15A to 600A converters, 3-ph. AC 400V / 4Q

Order No.	6RA23... - 6DV61									
	13	18	25	30	32	75	77	81	85	
Rated voltage/ output V	3-ph. 400 (+ 15% / - 20%) ¹⁾									
Rated supply voltage, electronics power supply V	3-ph. 400 (+ 15% / - 20%); I _n = 60mA;									
Rated supply voltage fan V						3-ph. 400 (± 15%); 0,18A, 90Watt Air flow: 570m ³ /h Fan noise: 63dBA				
Rated supply voltage, field V	2-ph. max.400 (+ 15%)									
Rated frequency Hz	Converters automatically adapt themselves to the frequency of the available supply voltage in the range from 45 to 65 Hz									
Rated DC voltage V	± 420									
Rated DC current A	15	30	60	100	140	200	250	400	600	
Rated output kW	6,3	12,6	25	42	59	84	105	168	252	
Power loss at rated current (approx.) W	80	140	230	320	440	650	800	1250	1850	
Rated DC voltage, field V	340									
Rated DC current, field A	3	5	10			15		25		
Operational ambient temperature °C	0 to 45 at I _{rated} self-ventilated ³⁾					0 to 35 at I _{rated} forced-cooled ³⁾				
Storage and transport temperature °C	- 30 to + 85									
Installation altitude above sea level	≤ 1000 m at rated DC current ⁴⁾									
Control stability	Δn = 0.1% with analog tachometer ²⁾ Δn = 0.006% with digital tachometer and digital setpoint ²⁾									
Humidity classification DIN 40040 SN 26556	F									
Deg. of prot. DIN 40050 IEC 144	IP 00									
Dimensions	refer to dimension drawings									
Weight (approx.) kg	3,5	11	14	14	16	23	23	31	31	

Explanation of the footnotes after the tables

30A to 600A converters, 3-ph. AC 500V / 1Q

Order No.	6RA23... - 6GS21							
	18	25	28	31	75	77	81	85
Rated voltage/ output V	3-ph. 500 (+ 10% / - 15%) ¹⁾							
Rated supply voltage electronics power supply V	3-ph. 400 (+ 15% / - 20%); I _n = 60mA							
Rated supply voltage, fan V					3-ph. 400 (± 15%); 0,18A, 90Watt Air flow: 570m ³ /h Fan noise: 63dBA			
Rated supply voltage, field V	2-ph. max.400 (+ 15%)							
Rated frequency Hz	Converters automatically adapt themselves to the frequency of the available supply voltage in the range from 45 to 65 Hz							
Rated DC voltage V	600							
Rated DC current A	30	60	90	125	200	250	400	600
Rated output kW	18	36	54	75	120	150	240	360
Power loss at rated current (approx.) W	140	230	320	440	650	800	1250	1850
Rated DC voltage, field V	340							
Rated DC current, field A	5	10			15		25	
Operational ambient temperature °C	0 to 45 at I _{rated} self-ventilated ³⁾				0 to 35 at I _{rated} forced-cooled ³⁾			
Storage and transport temperature °C	- 30 to + 85							
Installation altitude above sea level	≤ 1000 m at rated DC current ⁴⁾							
Control stability	Δn = 0.1% with analog tachometer ²⁾ Δn = 0.006% with digital tachometer and digital setpoint ²⁾							
Humidity classification DIN 40040 SN 26556	F							
Deg. of prot. DIN 40050 IEC 144	IP 00							
Dimensions	refer to the dimension drawings							
Weight (approx.) kg	11	14	14	16	23	23	31	31

Explanation of the footnotes after the tables

30A to 600A converters, 3-ph. AC 500V / 4Q

Order No.	6RA23... - 6GV61								
	18	25	30	32	75	77	81	85	
Rated voltage/ output V	3-ph. 500 (+ 10% / - 15%) ¹⁾								
Rated supply voltage electronics power supply V	3-ph. 400 (+ 15% / - 20%); I _n = 60mA								
Rated supply voltage, fan V					3-ph. 400 (± 15%); 0,18A, 90Watt Air flow: 570m ³ /h Fan noise: 63dBA				
Rated supply voltage, field V	2-ph. max.400 (+ 15%)								
Rated frequency Hz	Converters automatically adapt themselves to the frequency of the available supply voltage in the range from 45 to 65 Hz								
Rated DC voltage V	± 520								
Rated DC current A	30	60	100	140	200	250	400	600	
Rated output kW	16	31	52	73	104	130	208	312	
Power loss at rated current (approx.) W	140	230	320	440	650	800	1250	1850	
Rated DC voltage, field V	340								
Rated DC voltage, field A	5	10			15		25		
Operational ambient temperature °C	0 to 45 at I _{rated} self-ventilated ³⁾				0 to 35 at I _{rated} forced-cooled ³⁾				
Storage and transport temperature °C	- 30to + 85								
Installation altitude above sea level	≤ 1000 m at rated DC current ⁴⁾								
Control stability	Δn = 0.1% with analog tachometer ²⁾ Δn = 0.006% with digital tachometer and digital setpoint ²⁾								
Humidity classification DIN 40040 SN 26556	F								
Deg. of prot. DIN 40050 IEC 144	IP 00								
Dimensions	refer to the dimension drawings								
Weight (approx.) kg	11	14	14	16	23	23	31	31	

Explanation of the footnotes after the tables

1) For supply voltages below 360V (475V for 500V converters), the rated DC voltage for 1Q converters of 485 V (600 V) or for 4Q converters, from 420 V (520 V), can no longer be attained.

2) Conditions:

The closed-loop control stability is referred to the rated drive speed and when the SIMOREG K converter is in the warm condition. The following prerequisites are used as basis:

- Temperature changes of $\pm 10^\circ\text{K}$
- Supply voltage changes from + 10% / - 5% of the rated voltage
- Load changes up to 100% of the maximum torque
- Temperature coefficient of the temperature-compensated tachogenerator, 0.15‰ per 10°K (only for analog tachometer)
- Constant setpoint

3) Loading as a function of the cooling medium temperature

Ambient temp. or cooling medium temp.	Load value changes	
	for converters with self-cooling	for converters with enhanced air cooling
+ 35 °C		0 %
+ 40 °C		- 6 %
+ 45 °C	0 %	- 12 %
+ 50 °C a)	- 6 %	(- 17 %) a)
+ 55 °C	- 11 %	
+ 60 °C	- 18 %	

a) When operating converters ≤ 600 A with forced cooling, in spite of derating, at an ambient or cooling medium temperature of 50°C , this is only possible if the rated supply voltage of the converter fan is in the restricted tolerance range of 400 V + 10% -15%.

4) Load as a function of the installation altitude

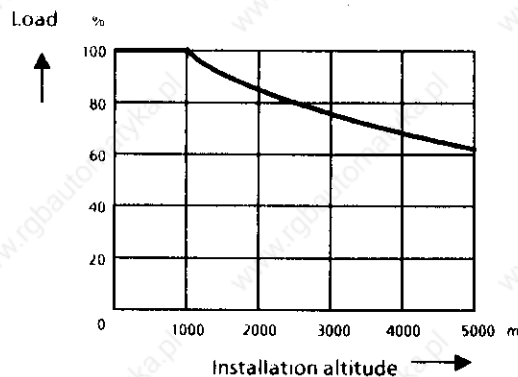

3.5 Applicable standards

VDE 0106, Part 100

Arrangement of operator control elements in the vicinity of components/parts at hazardous voltage levels.

VDE 0110, Part 1

Insulation coordination for electrical equipment in low-voltage installations.

Requirement for reliable isolation ⇒ degree of pollution 2 for boards and power section.

Only non-conductive pollution occurs. Occasional conductivity due to moisture condensation must be however expected.

"Moisture condensation is excluded, as the components are only permitted for humidity classification F."

VDE 0113 A2

Electrical equipment on industrial machines.

VDE 0160, Paragraphs 5.3.1.1.2 and 5.3.1.1.3

Regulations for equipping electrical power systems with electronic equipment.

VDE0298

Use of cables and insulated cables for electrical power systems.

DIN IEC 38

Supply voltage tolerance.

VDE 0843 Part 2, Part 3, Part 4 and IEC 801-2, 801-3, 801-4

Noise immunity

DIN IEC 68

Mechanical stressing

IEC 68-2-6, severity grade 12

4. Unpacking

SIMOREG converters are packed in the manufacturing plant as specified when ordered. A product packing label is provided on the box.

Avoid jolts and shocks during transport, e.g. when setting down.

Observe the instructions on the packing for transport, storage and correct handling.

The SIMOREG converter can be installed after it has been unpacked and checked to make sure that the scope of supply is complete and that the unit was not damaged.

The packing consists of cardboard and corrugated paper and can be disposed of corresponding to the local regulations for disposal of board products.

You should notify your freight forwarder immediately if you discover any transportation damage.

5. Installation



CAUTION

Bodily injury or material damage can result if the equipment is carelessly lifted.

The converter should only be lifted using suitable equipment and under the instructions of appropriately qualified personnel.



The user is responsible for installing the converter, motor, transformer as well as other equipment according to the safety regulations (e.g. DIN, VDE), as well as all other relevant national or local regulations regarding cable dimensioning and protection, grounding, isolating switch, overcurrent protection etc.

The converter must be installed in accordance with the relevant safety regulations (e.g. DIN, VDE), as well as all other relevant national and local regulations. It must be ensured that the grounding, cable dimensioning and appropriate short-circuit protection have been implemented to guarantee operational safety and reliability.

- **Converter with 15A rated current**

These can either be mounted flat on a mounting surface in the cubicle or machine rack, on edge, or inserted in withdrawable racks (refer to dimension drawings, Section 5.1).

- **Converter with 30A to 600A rated current**

These are mounted vertically in cubicles or machine racks with the power connections towards the bottom (refer to dimension drawings, Section 5.1).

**WARNING**

100 mm clearance must be kept above and below the converter in order to ensure an unrestricted cooling air intake and outlet. If this clearance is not kept, there is danger that the converter will overheat!

5.1 Dimension drawings**Converter type D... / 15**

Flat mounting:

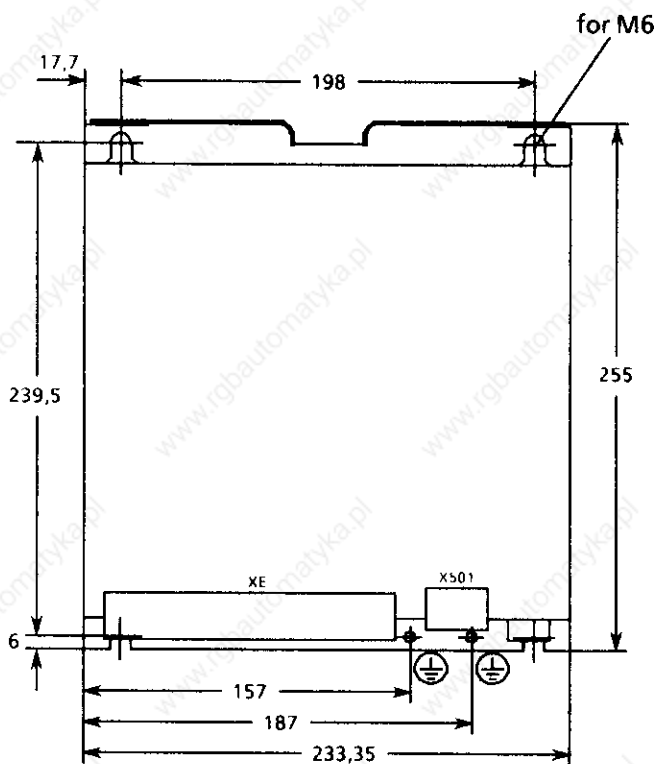

M5x16 connecting stud

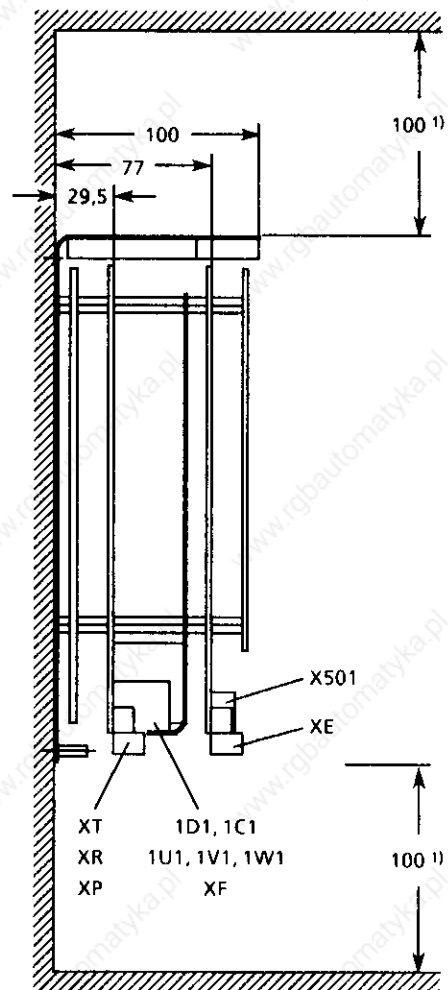
Power connecting terminals: 4mm²

- 1) Minimum clearance for air circulation.
It should be ensured that there is sufficient cooling air intake!

Mounting the converter on its end:

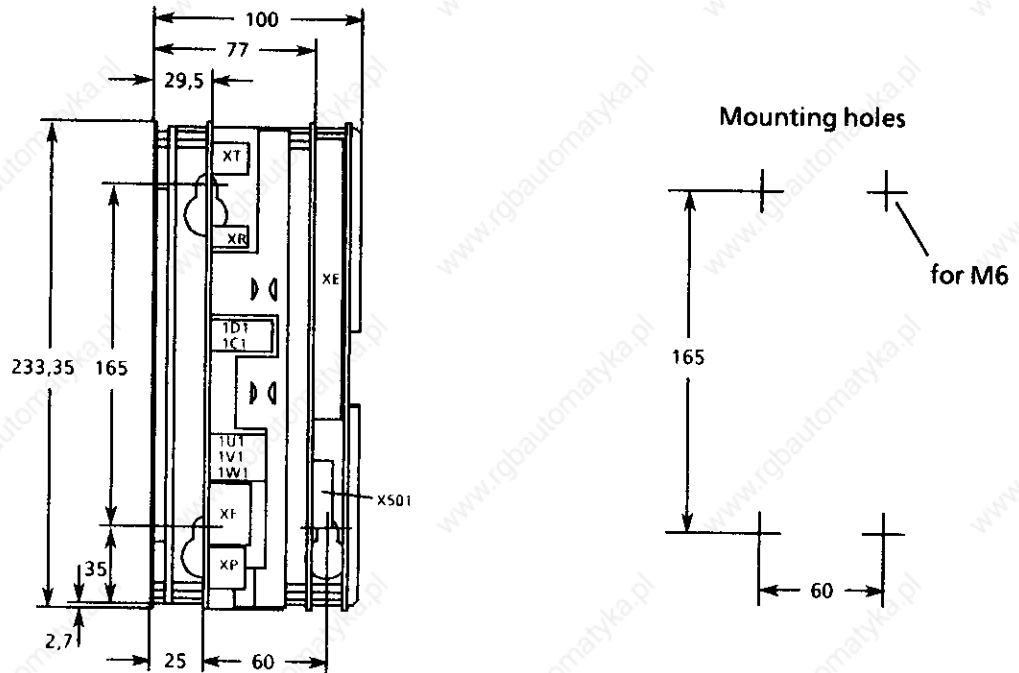

Mounting the converter in the ES 902 C packaging system:

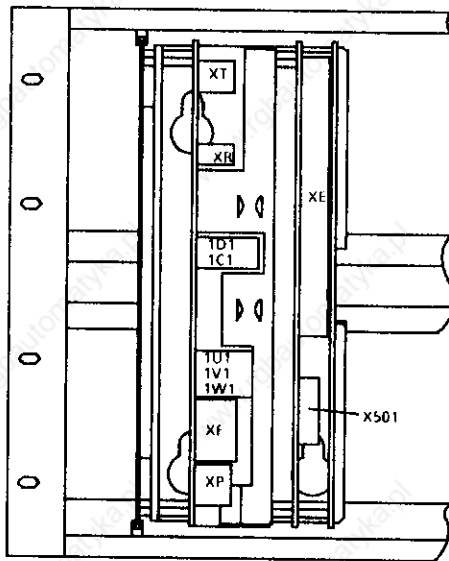

Space requirement in the subrack: 22 grid divisions (111.76mm)

- without supplementary boards
- with the minimum necessary clearance between two converters

Converter type D... / 30 - 60

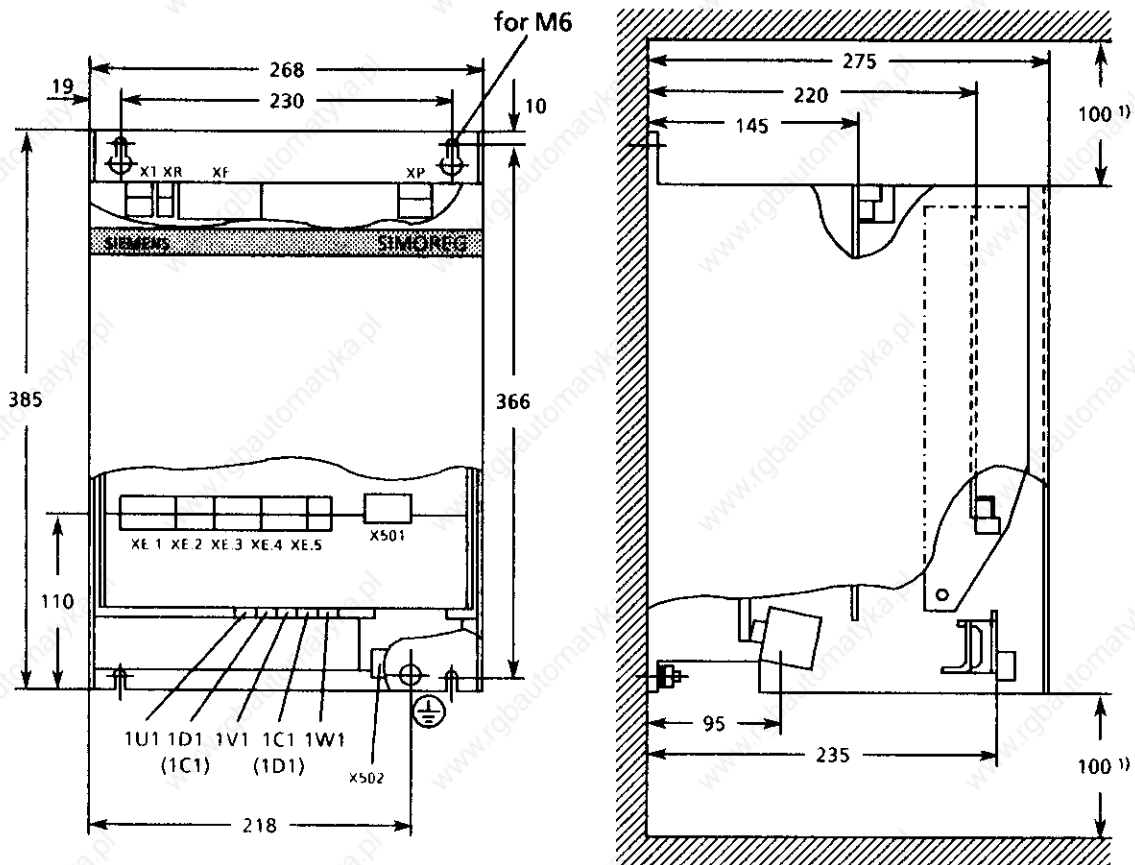

⊕ M6x16 connecting studs

Power connecting terminals for 30A converters: 10mm²
60A converters: 35mm²

- 1) Minimum clearance for air circulation.
It should be ensured that there is sufficient cooling air intake!

Converter type D... / 90 - 140

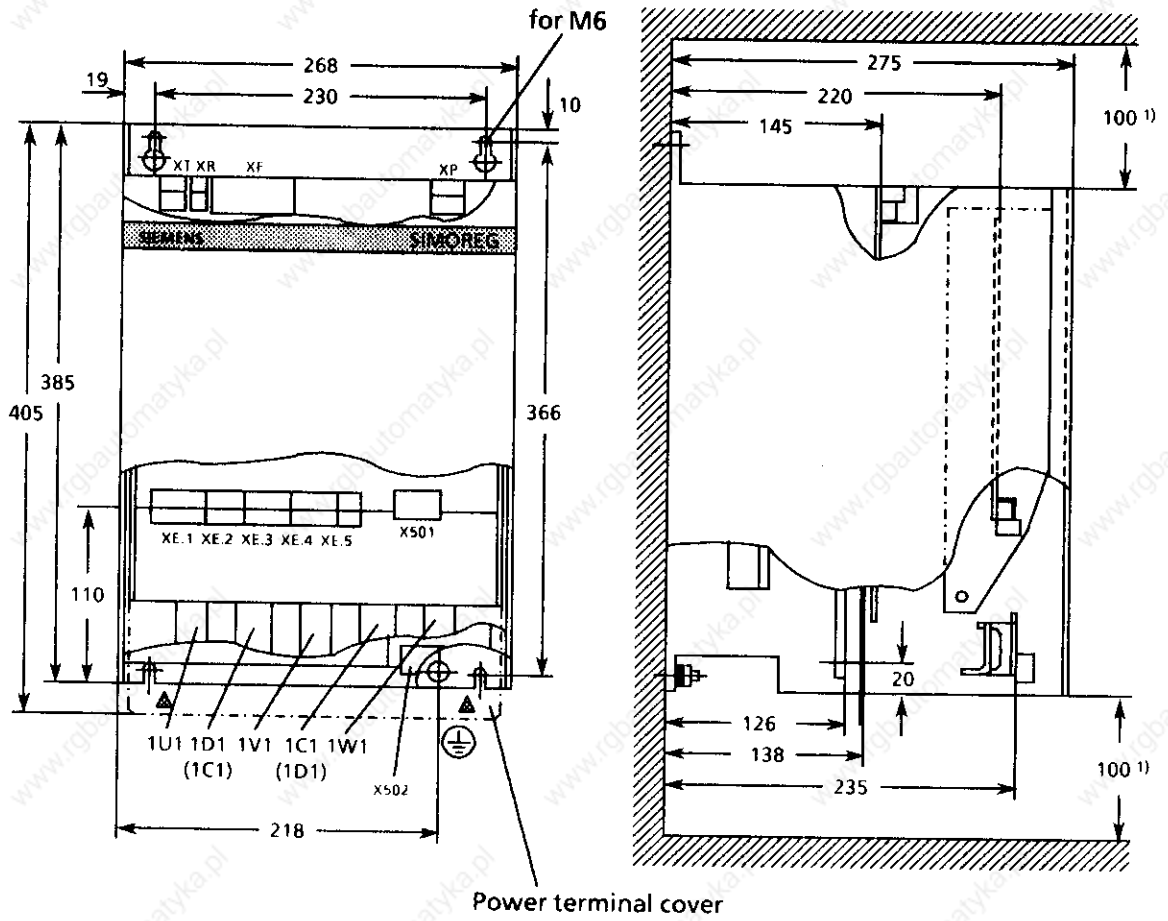

⊕ M6x16 connecting studs

Power connection 1U1, 1V1, 1W1: M8
 1D1, 1C1: M10

- 1) Minimum clearance for air circulation
 It should be ensured that there is sufficient cooling air intake!

Converter type D... / 200 - 250

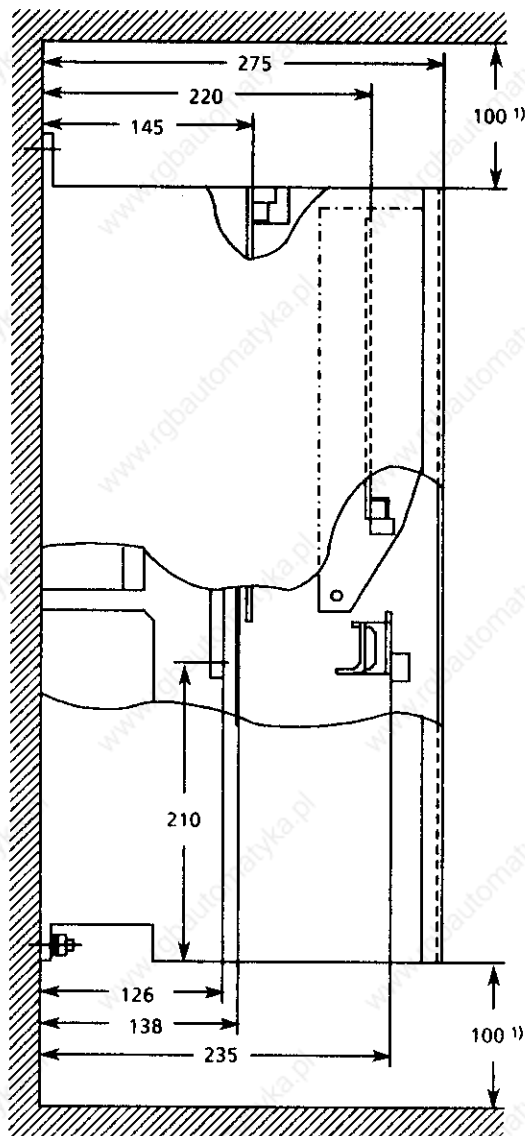
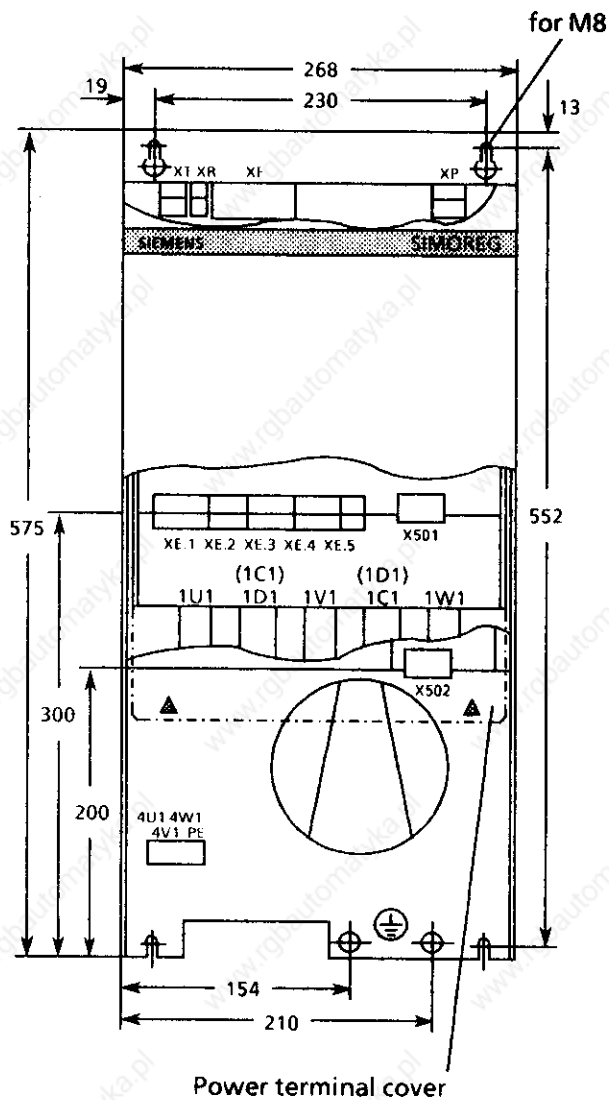

⊕ M8x20 connecting studs

Power connection 1U1, 1D1, 1V1, 1C1, 1W1: M10

- 1) Minimum clearance for air circulation
It should be ensured that there is sufficient cooling air intake!

Converter type D... / 400 - 600

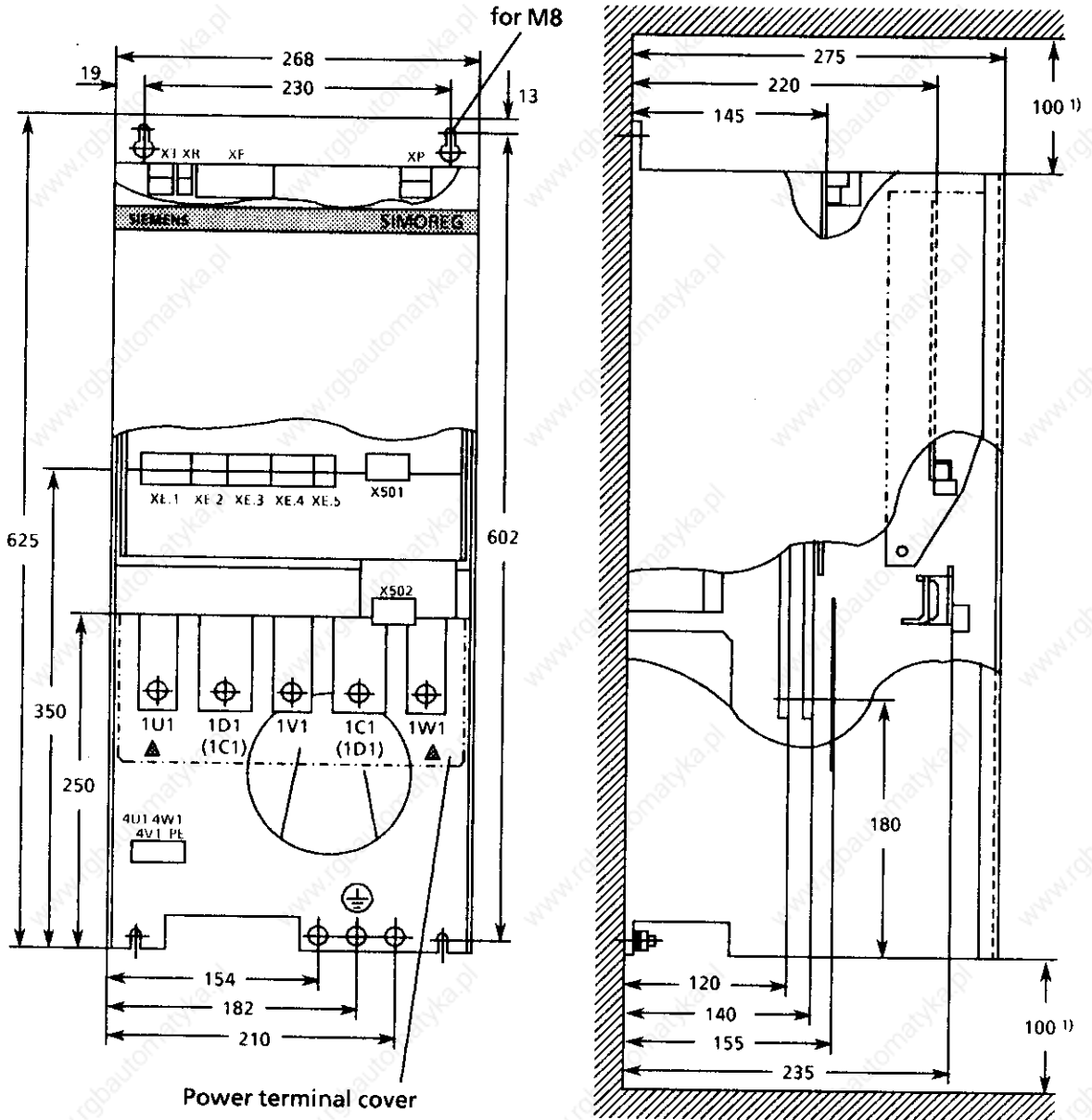

Power terminal cover

⊕ M8x20 connecting studs

Power connection 1U1, 1D1, 1V1, 1C1, 1W1: M10

- 1) Minimum clearance for air circulation
It should be ensured that there is sufficient cooling air intake!

5.2 Position of PC boards, ribbon cables and terminal strips for 15A converters (basic converters)

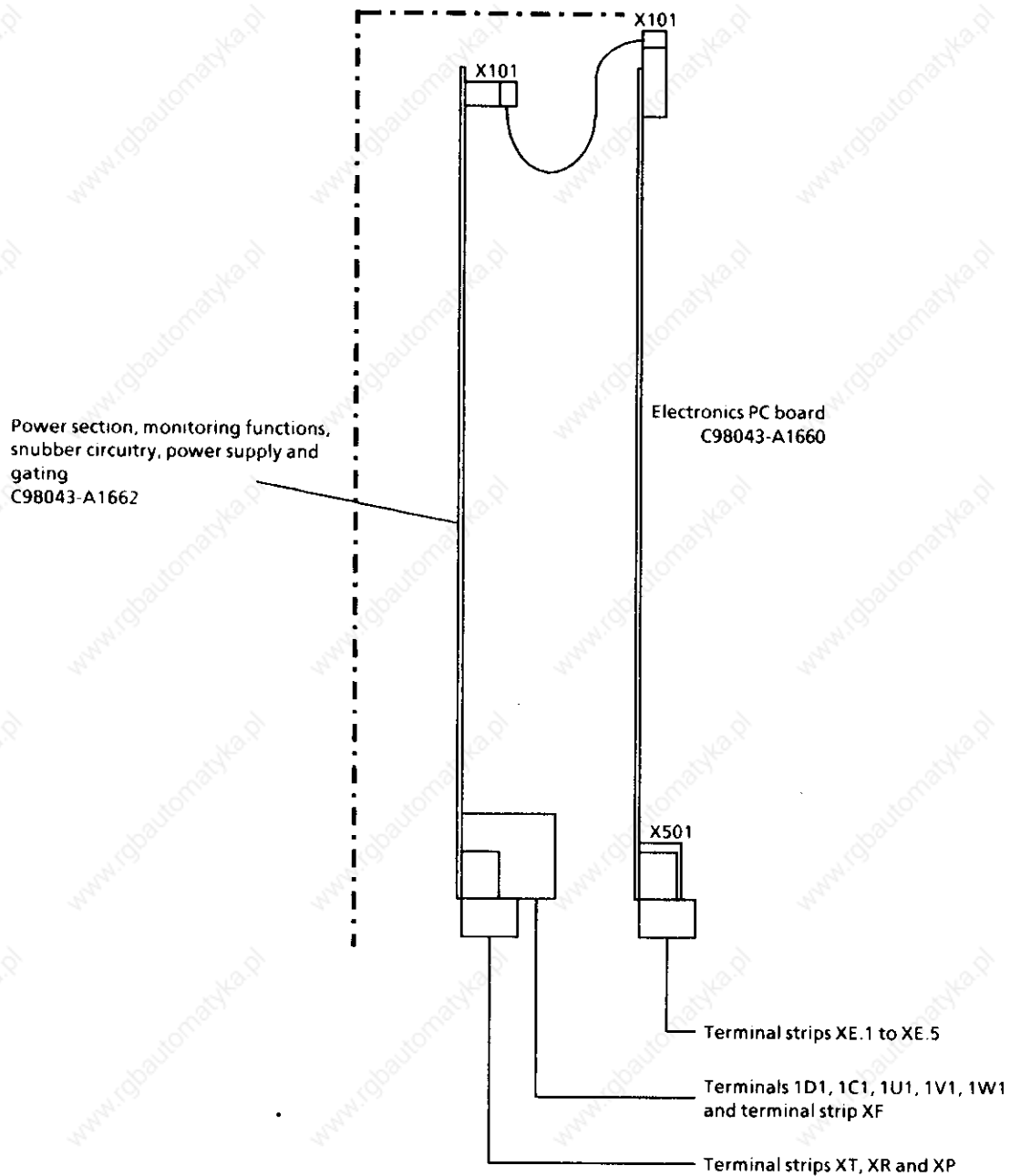

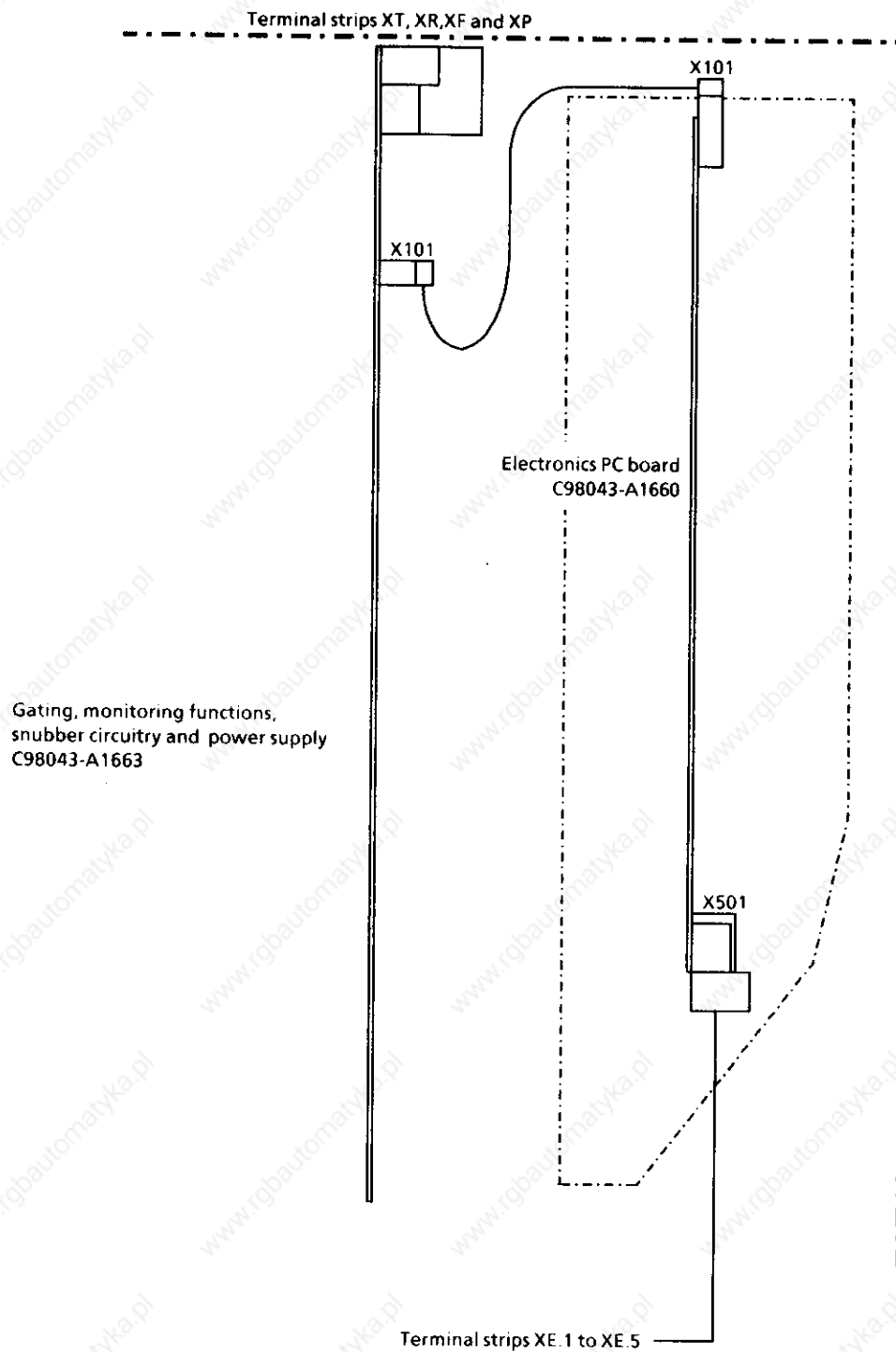
for 30A - 600A converters (basic converters)

5.3 Location of the EPROMs and mounting options

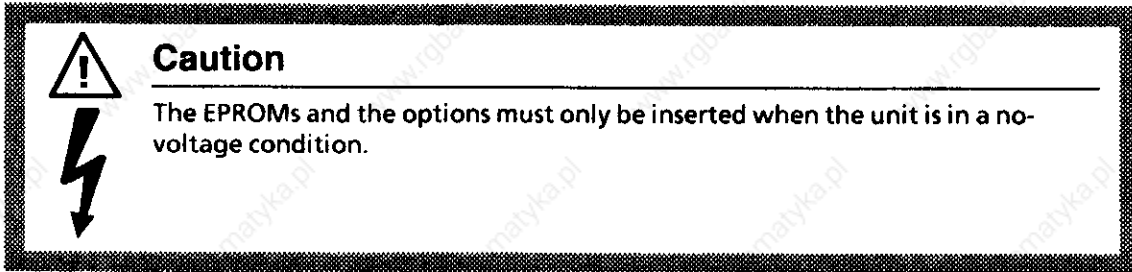

5.3.1 Location of the EPROMs

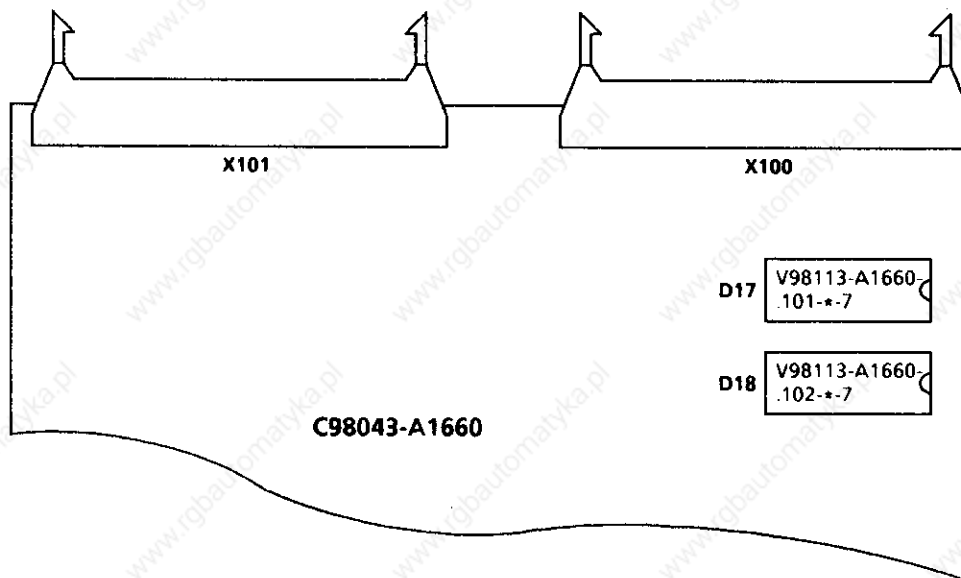

EPROMs D17 and D18 are inserted on the electronics board C98043-A1660, and can be easily replaced.

5.3.2 Mounting of the option boards

Z11 (Order No.: 6RX1230-0AK01)
Z14 (Order No.: 6RX1230-0AK05)

The option boards can be used from version 10 of the basic converter board C98043-A1660 (the last two digits of the board designation C98043-A1660-L*-10, refer to the print to the left of the parameterizing unit which identifies the board version).

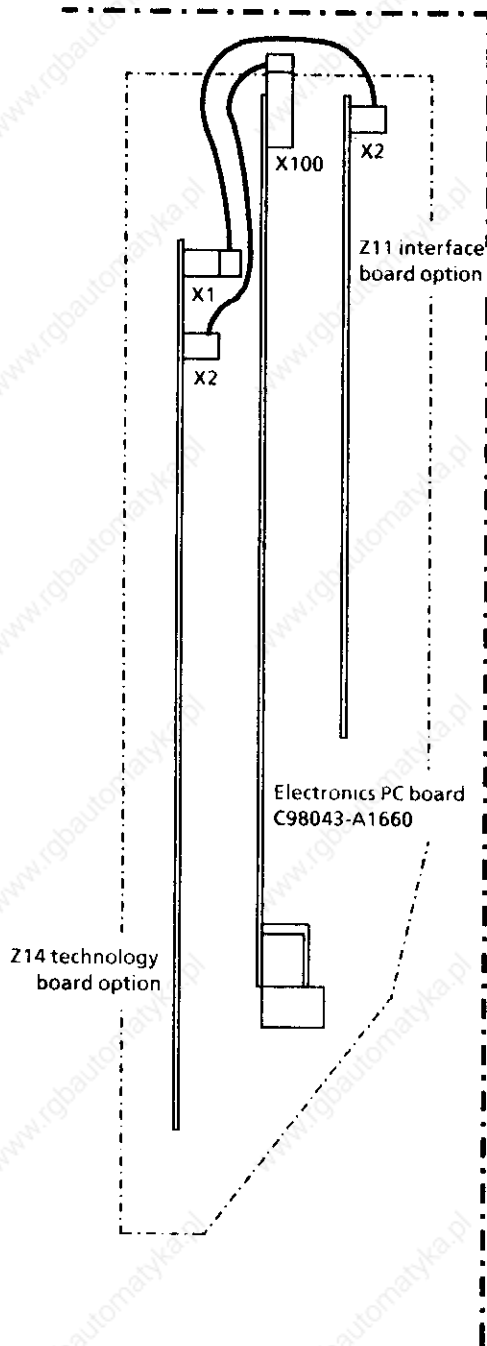

The option boards are inserted in the electronics holder at the appropriate position, and are retained in place using two captive screws.

The electrical connection is established using ribbon cables, soldered at one side and more specifically, from the Z14 option board, connector X2 to the electronics PC board, connector X100 and the Z11 option board, connector X2 to option board Z14, connector X1.

If only the Z11 option board is to be inserted, connector X2 should be connected with the electronics PC board, connector X100.

If only the Z14 option board is inserted, then only connector X2 has to be connected to the electronics PC board, connector X100.

5.3.3 Interface expansion (Order No.: 6RX1240-0AL01)

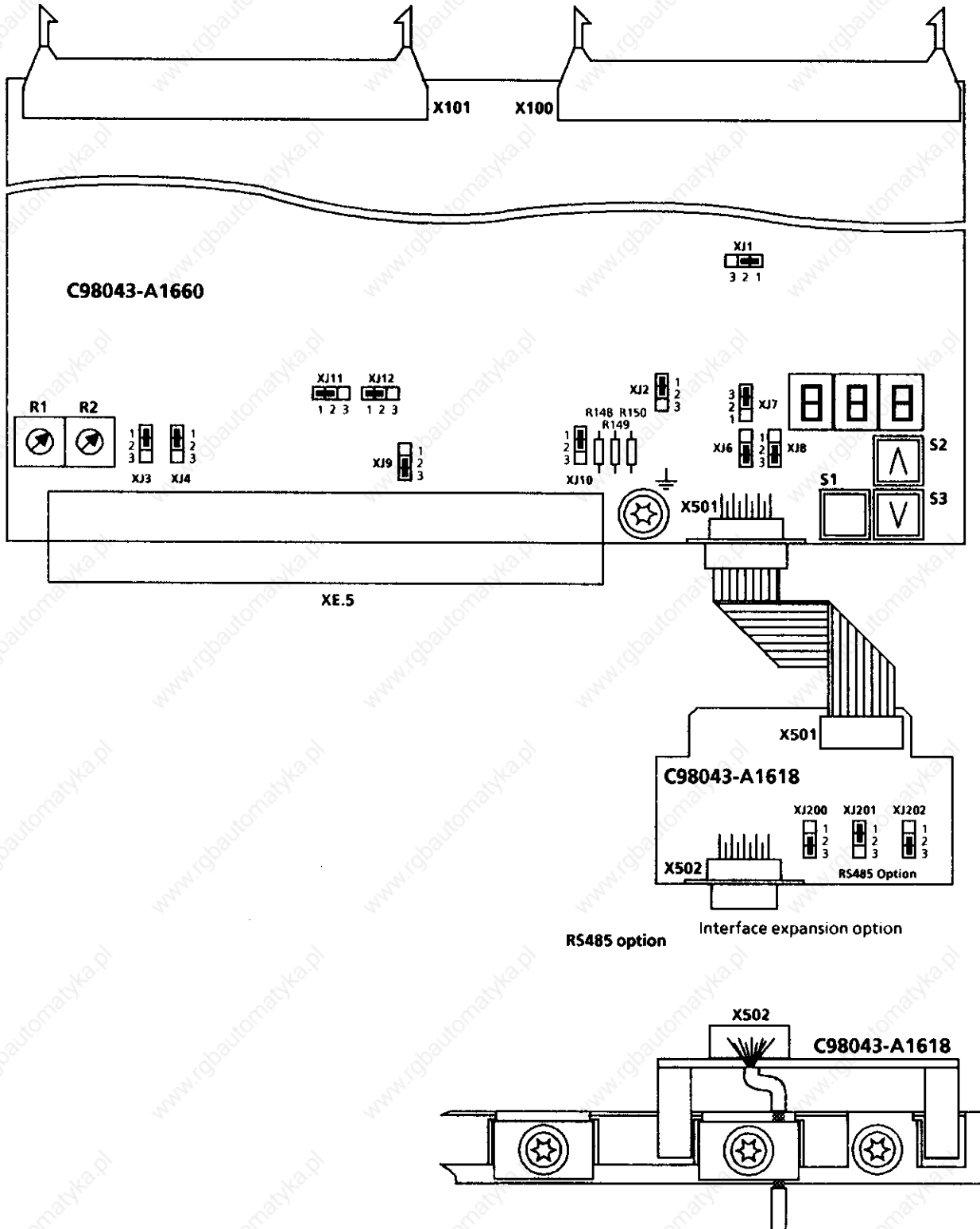

The interface expansion option is snapped onto the righthand side of the screen connecting bar. Connector X501 is connected with connector X501 on the electronics PC board using a ribbon cable. Plug-in jumpers XJ200 and XJ202 are in the 2-3 setting, and XJ201 in the 1-2 setting on the interface converter when supplied (no bus termination). Plug-in jumpers XJ2, XJ6, XJ7 and XJ8 should be brought into the 2-3 setting on the electronics PC board. The interface cable at connector X502 must be screened and the screen must be grounded at both ends.

6 Connecting-up



WARNING

This converter contains hazardous voltages and rotating mechanical components (fans). Death, severe bodily injury and material damage can occur if the instructions in this Manual are not observed.

The unit is at a dangerous potential even when the converter line contactor is open. The gating board (the PC board, mounted in the lower section of the housing) contains many circuits at hazardous voltage levels.



The user is responsible for installing the converter, motor, transformer and the other equipment according to the relevant safety regulations (e.g. DIN, VDE) as well as all other national and local regulations and specifications regarding cable dimensioning and protection, grounding, isolator, overcurrent protection etc.

On the customer side, a dangerous voltage level can be connected to a signaling relay.

The converters **MUST NOT** be connected to a supply with earth-leakage circuit-breaker (VDE 0160, Section 6.5) as a DC component can be included in the fault current when a fault to frame or ground occurs, which either prevents or hinders a higher-level earth leakage-circuit breaker from tripping. In this case, all loads connected to this earth-leakage circuit-breaker also have no protection.

An operating stop is not realized in the sense of the binding regulations (DIN VDE 0113, Section 1) if the drive is only shutdown using terminal 37 on A1660 (ON/OFF) or terminal 38 on A1660 (enable). If there is a fault in the converter electronics the motor could accidentally start to rotate.

When connecting up the units according to Section 6.2, the DC output is not electrically isolated from the supply.



WARNING

The external surfaces of ungrounded converters might be at a dangerous potential. This could result in death, bodily injury or significant material damage.



If the converter (cubicle or chassis unit) is installed so that it is not grounded, to ensure the safety of operating personnel, a grounding cable must be connected to the housing. The motor frame, transformer housing and the operator control section must also be grounded. The safety regulations (e.g. DIN, VDE) as well as all other relevant national and local regulations must be observed regarding the converter grounding.

All rotating components must be provided with protective guards.

NOTE

The converters should be wired-up according to the binding connecting terminal diagram or recommended connection. Setpoint and actual value cables should be screened, and routed separately from load voltage cables. Control cables and field cables must be routed in separate cable ducts.

To guarantee noise immunity (EMC), the converter grounding stud should be connected to the cubicle through the shortest possible path.

6.1 Instructions for connecting screened control cables**Converter type D ... / 15**

C98043-A1662 C98043-A1660

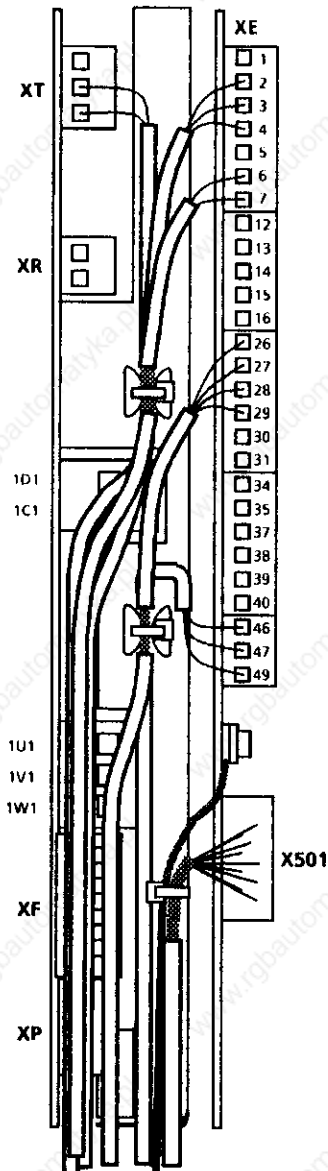

Converter type D.../30 - 600

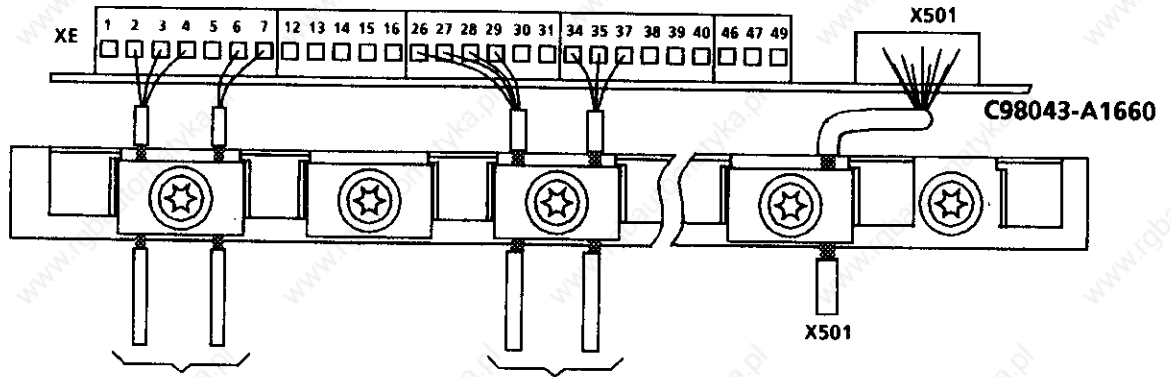

The cables which are clamped under the same cable clamp must have approximately the same diameter.

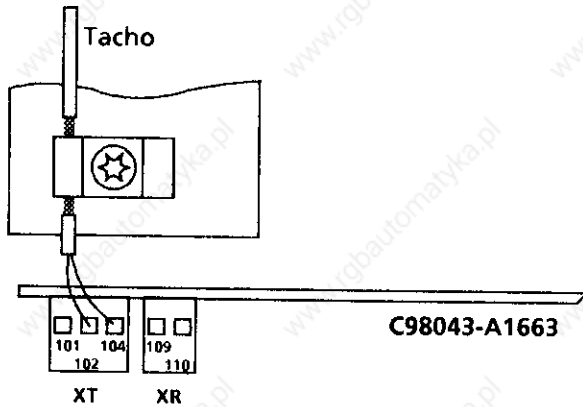

NOTE

The connecting cables at the serial interface of the electronics board (X501) and the interface expansion (X502) must be screened. The screens must be grounded at the locations provided where the cable enters the converter. The screens must also be grounded at the other cable ends.

6.2 Block diagrams with recommended connection

Converter type D.../15

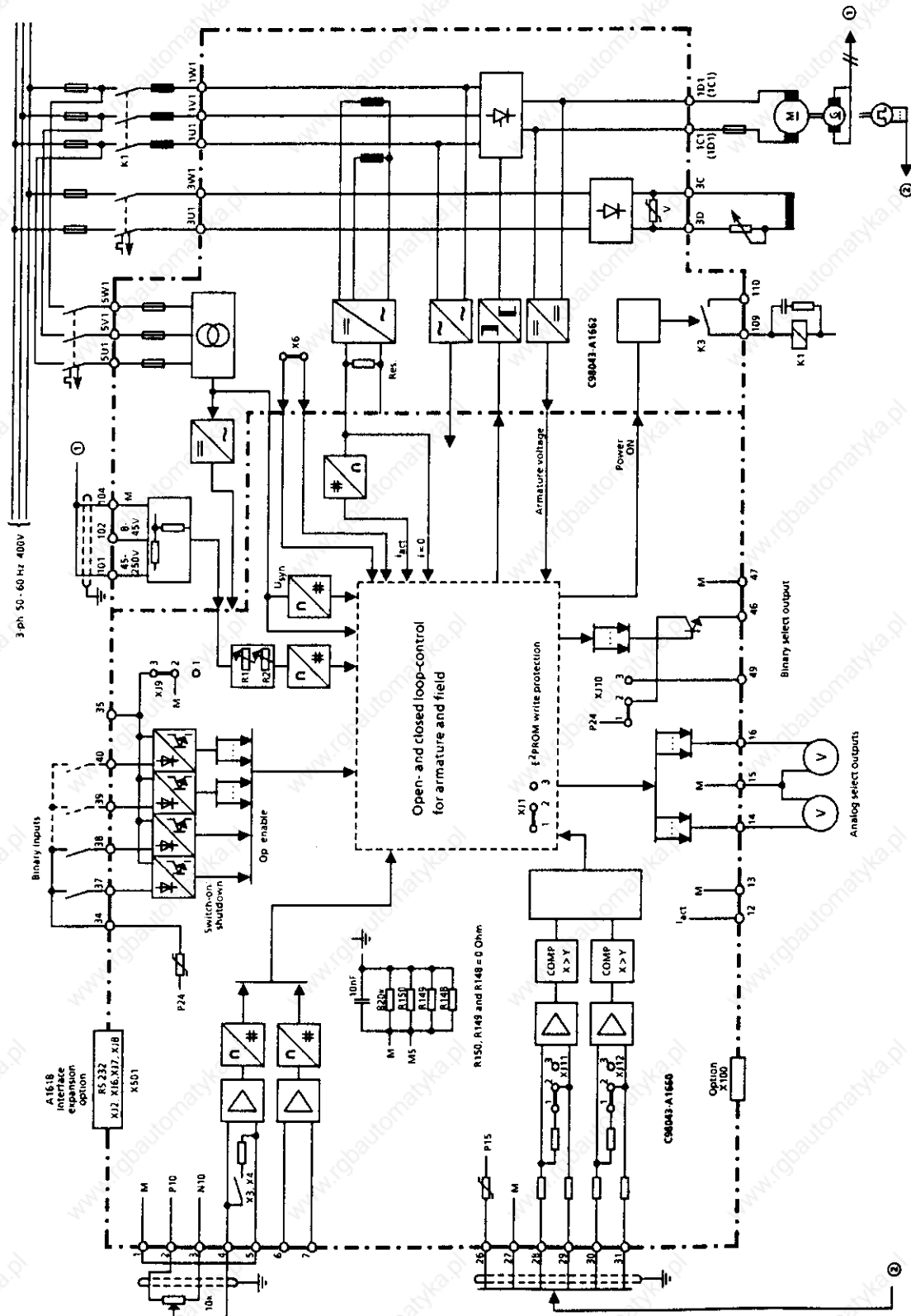

Converter type D.../30 - 600

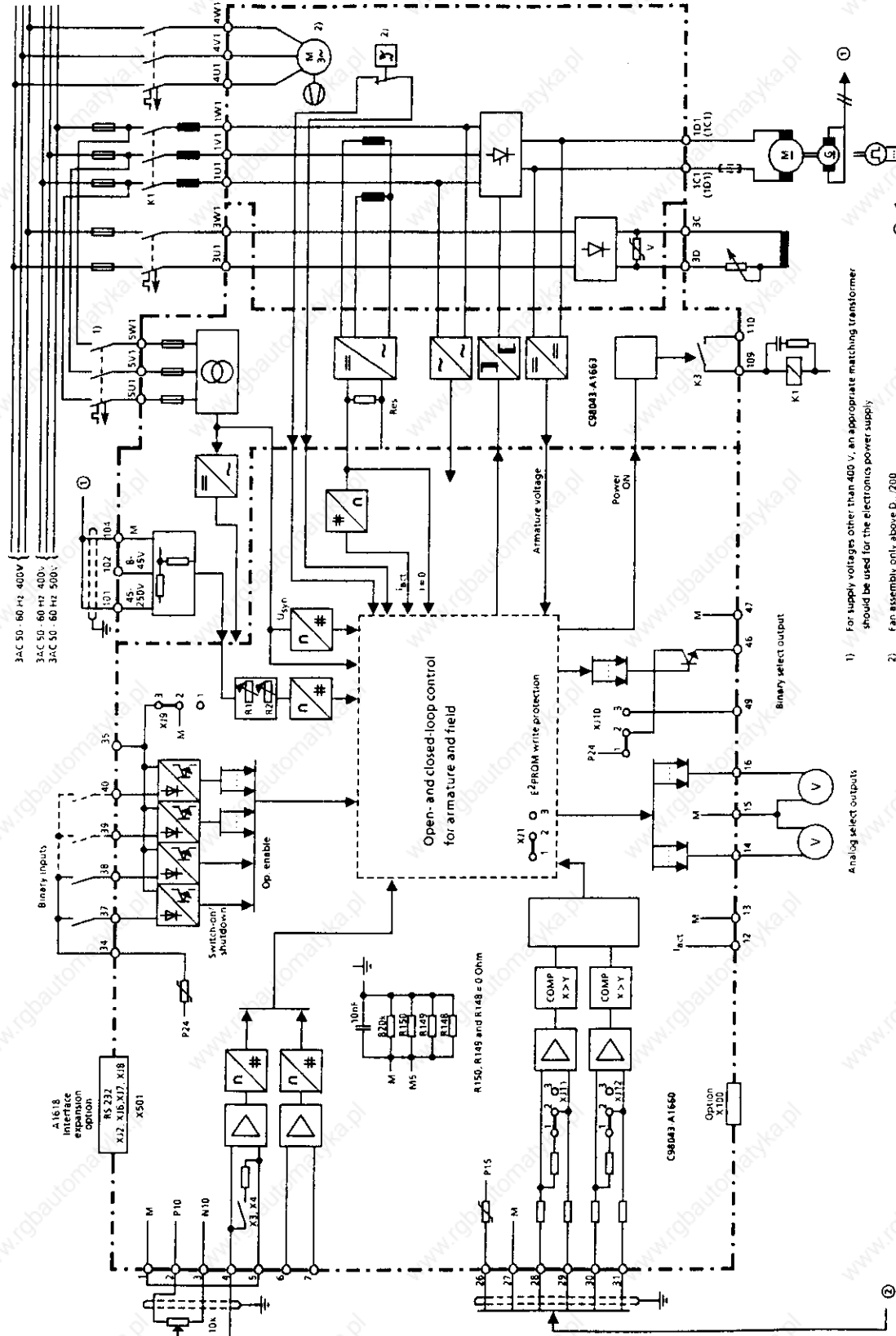

- 1) For supply voltages other than 400 V, an appropriate matching transformer should be used for the electronics power supply.
- 2) Fan assembly only, above D.../200

6.3 Power connections

Converter type D... / 15 Mreq-GeG6V61

Power connection for product version: starting with A4

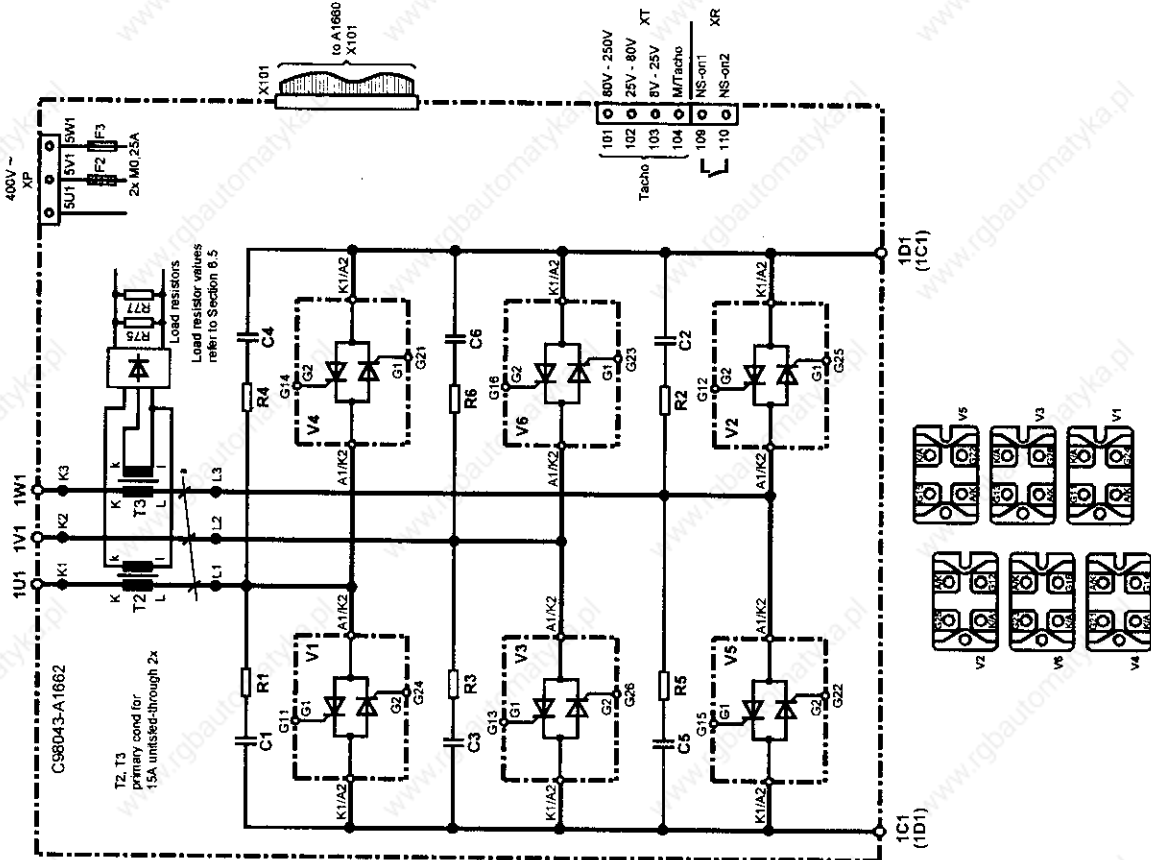

Power connection for product version: A1 to A3

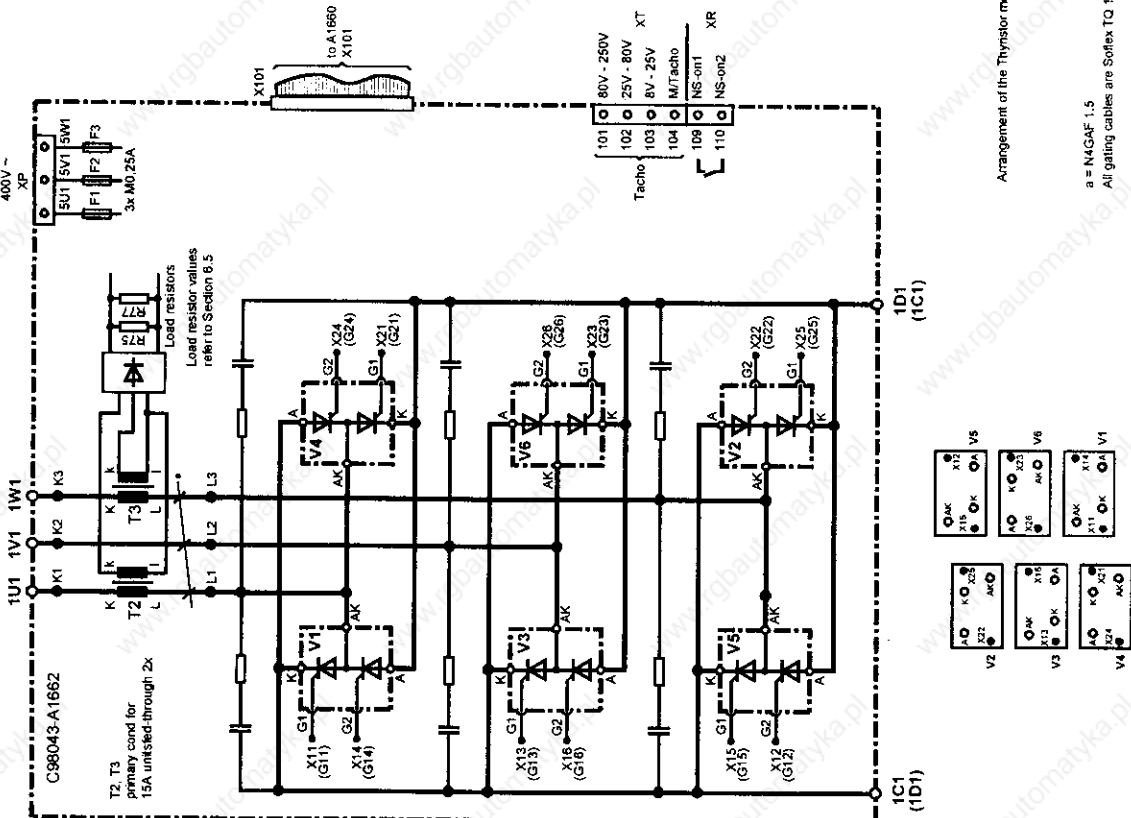

Arrangement of the Thyristor modules

a = N4GAF 1.5
All gating cables are Softex TQ 105° 0.5mm²

Converter type D... / 30 - 250 Mre-GeE(F)6S21

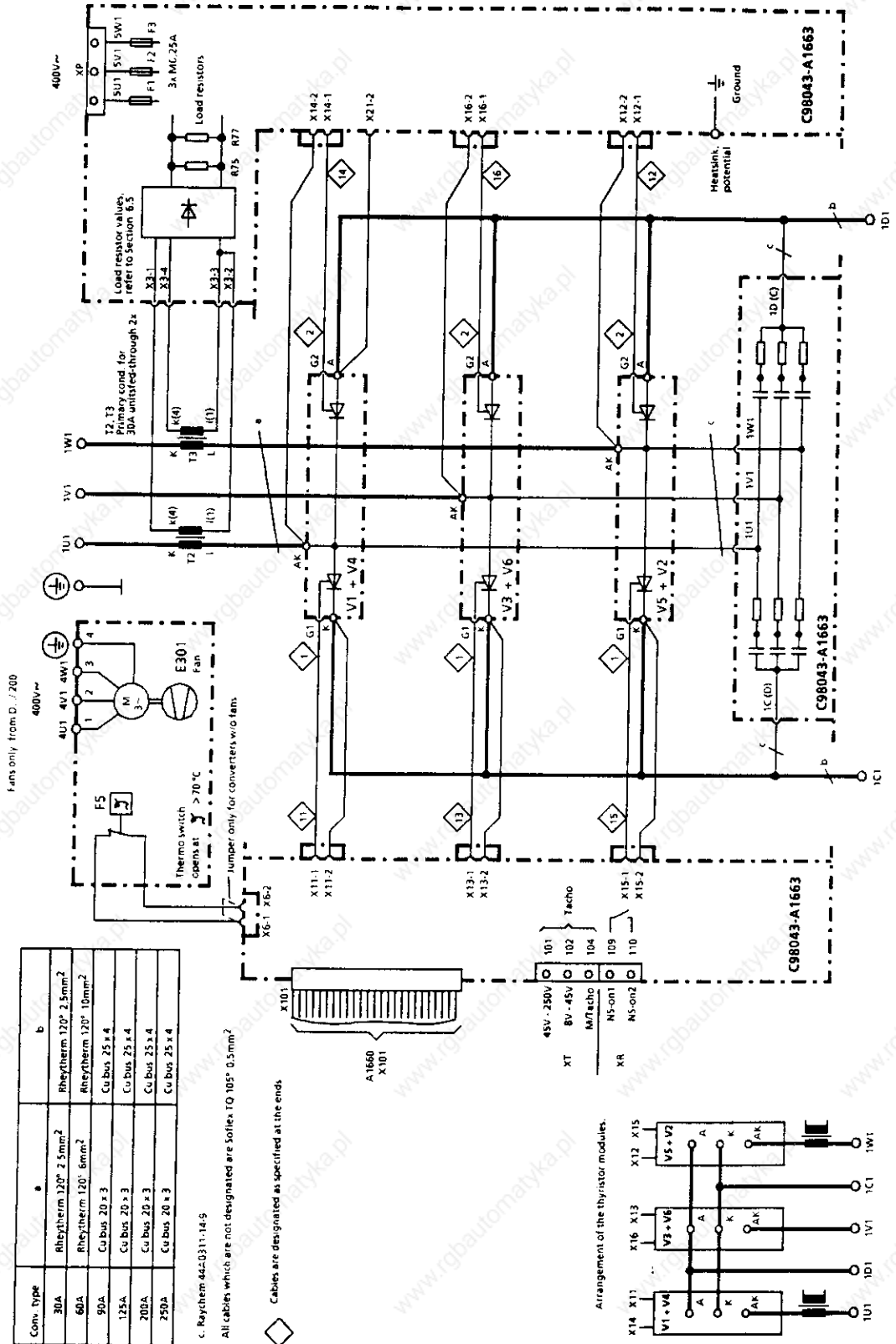

Conv. type	a	b
30A	Rheitherm 120° 2.5mm ²	Rheitherm 120° 2.5mm ²
60A	Rheitherm 120° 6mm ²	Rheitherm 120° 10mm ²
90A	Cu bus 20 x 3	Cu bus 25 x 4
125A	Cu bus 20 x 3	Cu bus 25 x 4
200A	Cu bus 20 x 3	Cu bus 25 x 4
250A	Cu bus 20 x 3	Cu bus 25 x 4

c. Raychem 4420311-14.9
 All cables, which are not designated are Soflex IO 105° 0.5mm²

◇ Cables are designated as specified at the ends

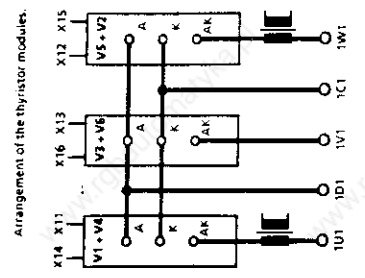

Converter type D... / 30 - 250 Mreq-GeG(F)6V61

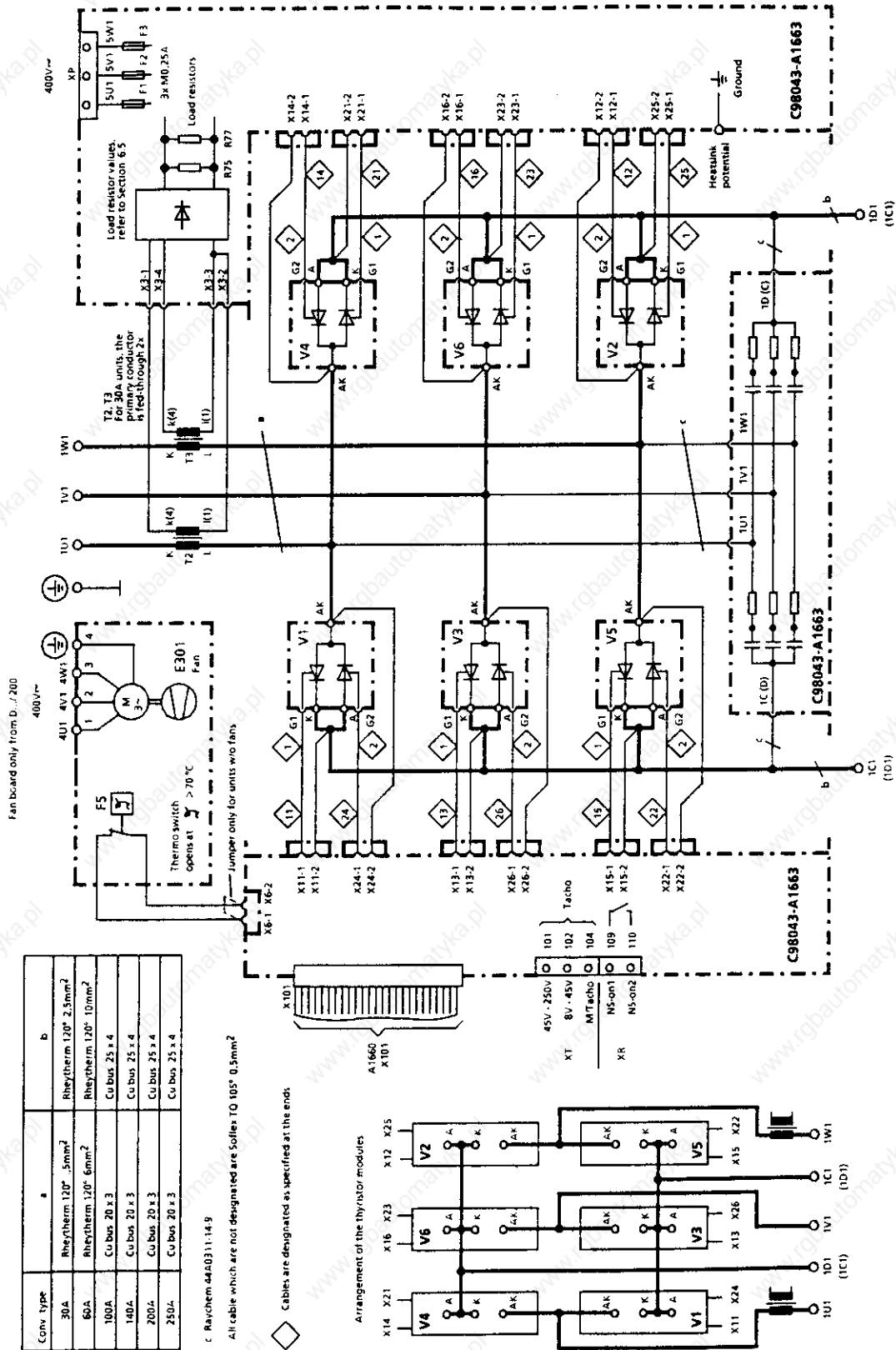

Conv. type	a	b
30A	Rheytherm 120° 5mm ²	Rheytherm 120° 2,5mm ²
60A	Rheytherm 120° 6mm ²	Rheytherm 120° 10mm ²
100A	Cu bus 20 x 3	Cu bus 25 x 4
140A	Cu bus 20 x 3	Cu bus 25 x 4
200A	Cu bus 20 x 3	Cu bus 25 x 4
250A	Cu bus 20 x 3	Cu bus 25 x 4

c. Raychem 44A0311-14-9
 All cable which are not designated are Sollex TO 105° 0.5mm²

◇ Cables are designated as specified at the ends.

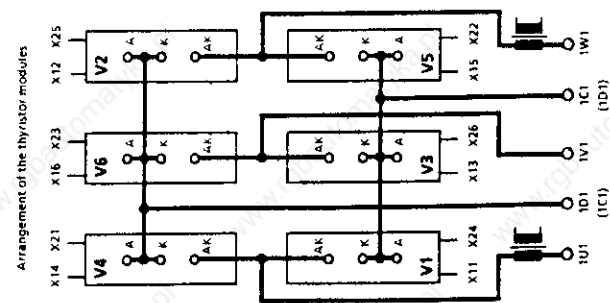

Converter type D... / 400 - 600 Mre-GeEF6S21

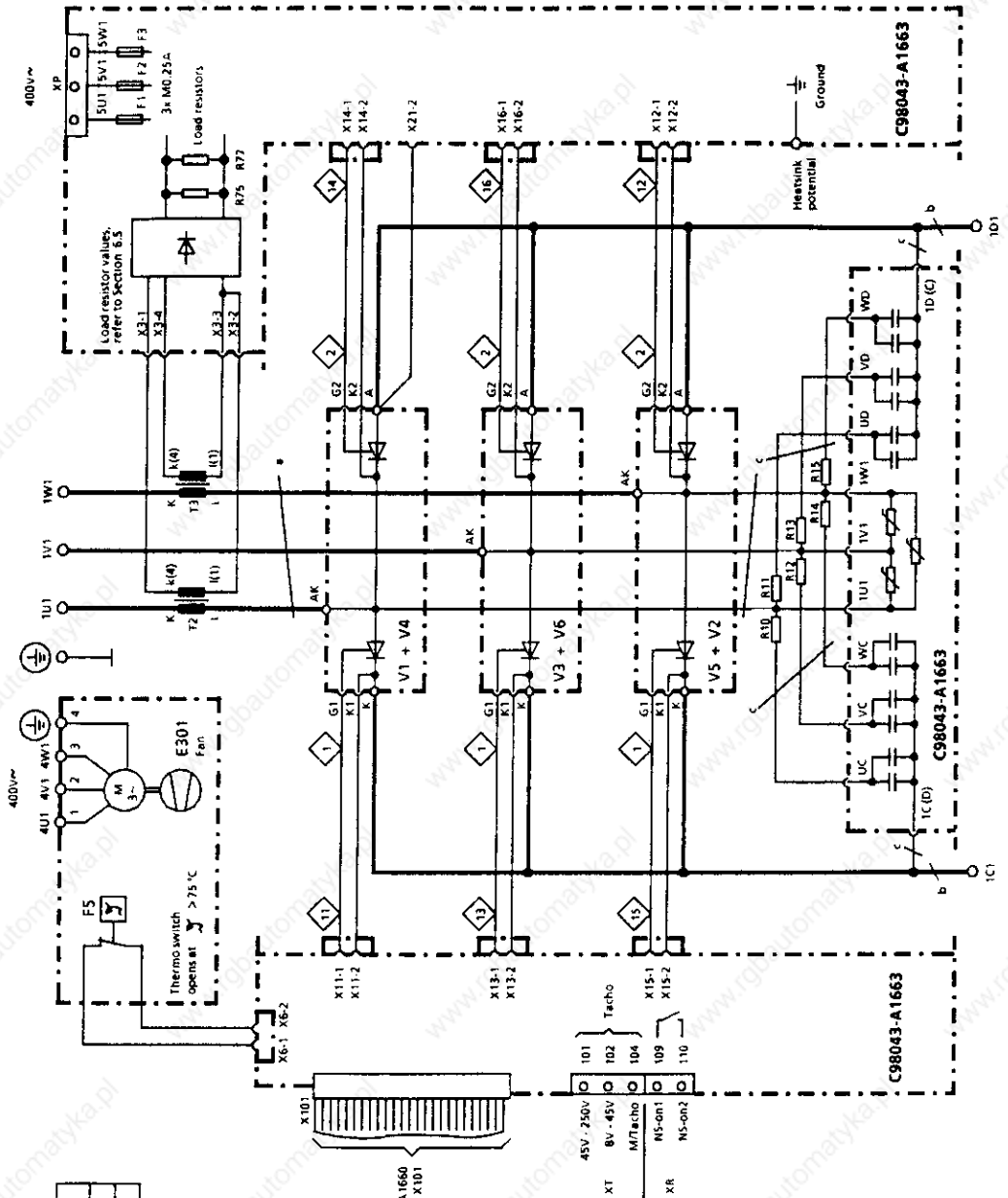

Conv. type	a	b
400A	Cu bus 30 x 5	Cu bus 40 x 5
600A	Cu bus 30 x 5	Cu bus 40 x 5

c. Raychem 44A0311-149
 All cables which are not designated are Sollex TQ 105^o 0.5mm²

◇ Cables are designated as specified at the ends

Arrangement of the thyristor modules.

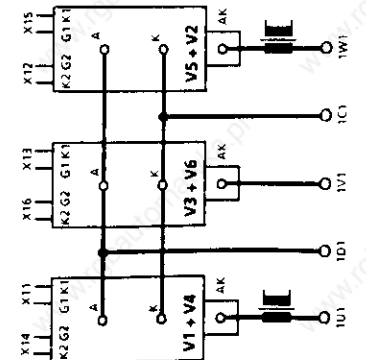

Converter type D... / 400 - 600 Mreq-GeGF6V61

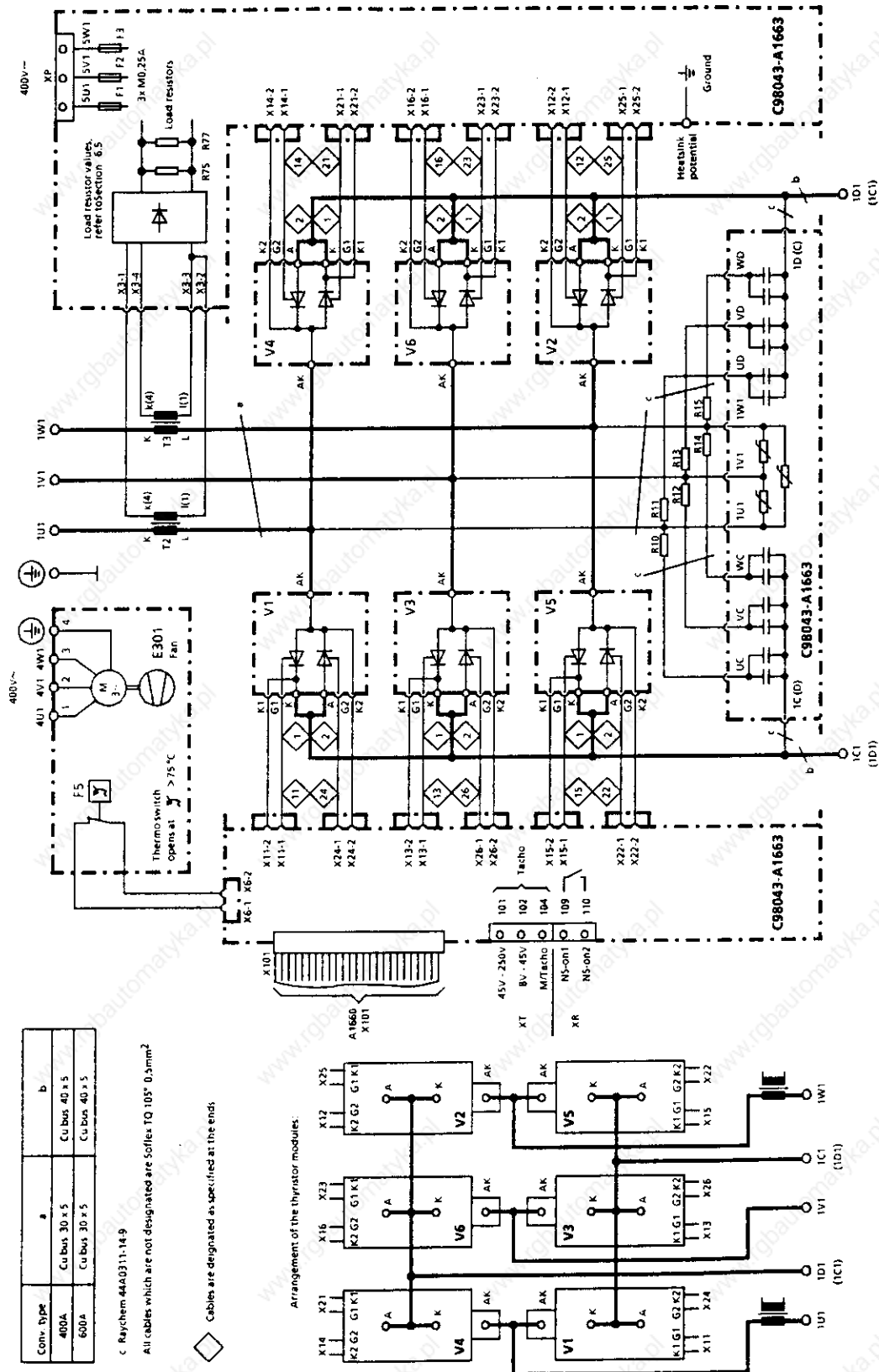

Conv. type	a	b
400A	Cu bus 30 x 5	Cu bus 40 x 5
600A	Cu bus 30 x 5	Cu bus 40 x 5

c Raychem 44A0311-14-9
 All cables which are not designated are Solflex TQ 105⁰ 0,3mm²

◊ Cables are designated as specified at the ends.

Arrangement of the thyristor modules.

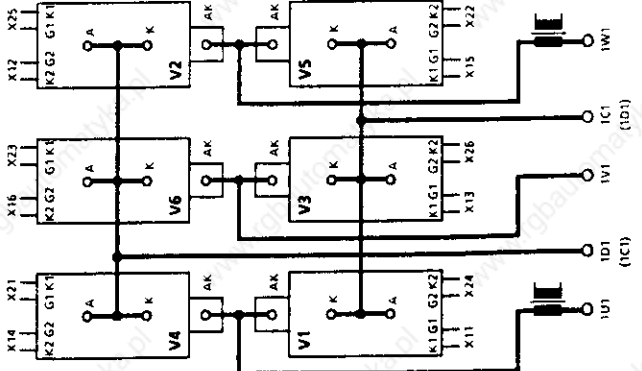

6.4 Field supply
 Converter type D ... / 15

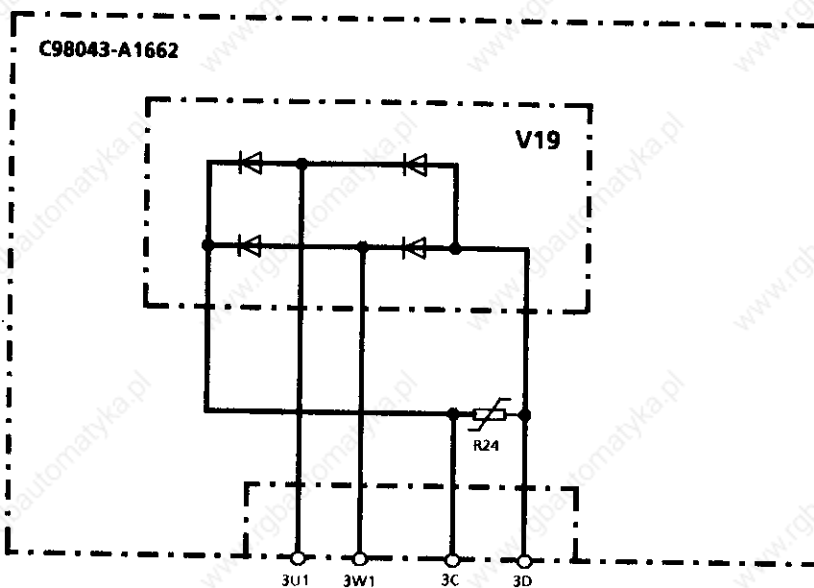

Converter type D ... / 30 - 600

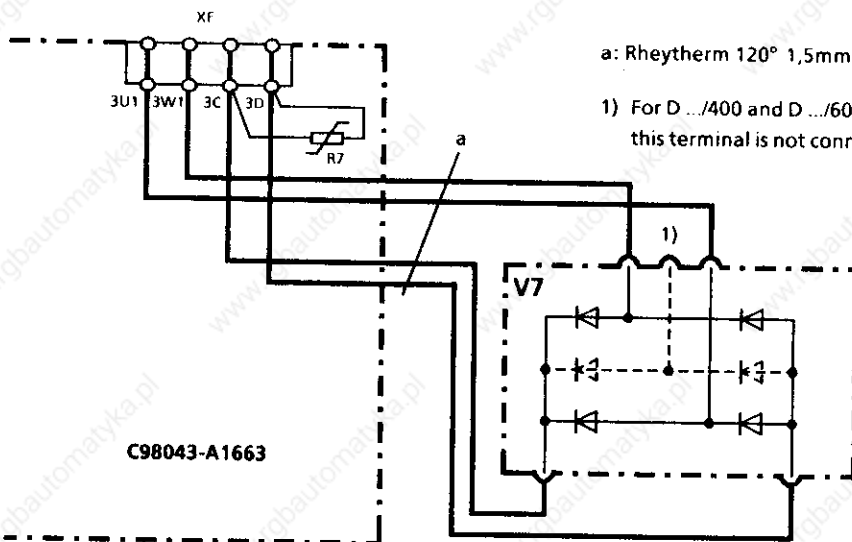

a: Rheytherm 120° 1,5mm²

1) For D ... /400 and D ... /600 3-ph. rectifier, whereby this terminal is not connected

NOTE

When using an external field supply converter (field-weakening operation), the field current setpoint can be output via one of the two analog select outputs (terminal 14 or 16 on board A1660) (recommended circuit configurations, Section 10.16).

6.5 Load resistors (räumliche Anordnung siehe nächste Seite)

IMPORTANT NOTE

We do not accept any liability for damage incurred due to incorrect load or shunt resistors being installed.

The CT is destroyed if the plug-in connection X3 (on A1663) is interrupted.

Spare boards are supplied without load resistors!

Load resistors on A1662 and A1663					
Converter rated current	Reduced rated current	Current transformer ratio	Load resistors		Effective value
			R75	R77	
A	A	1:	Ω	Ω	Ω
15		500	51	100	33,775
	10	500	51		51
	5	500		100	100
30		1000	51	100	33,775
	20	1000	51		51
	10	1000		100	100
60		2000	51	100	33,775
	40	2000	51		51
	20	2000		100	100
90		2000	34	66,5	22,498
	60	2000	34		34
	30	2000		66,5	66,5
100		2000	30	61,9	20,207
	67	2000	30		30
	32	2000		61,9	61,9
125		2000	24,3	48,7	16,211
	82	2000	24,3		24,3
	41	2000		48,7	48,7
140		2000	21,5	44,2	16,211
	93	2000	21,5		21,5
	45	2000		44,2	44,2
200		2000	15,4	29,4	10,106
	130	2000	15,4		15,4
	68	2000		29,4	29,4
250		2000	12,1	24,3	8,078
	165	2000	12,1		12,1
	82	2000		24,3	24,3
400		2000	7,68	15	5,079
	260	2000	7,68		7,68
	133	2000		15	15
600		2000	5,1	10	3,377
	392	2000	5,1		5,1
	200	2000		10	10

Location of connectors and load resistors

PC board C98043-A1660

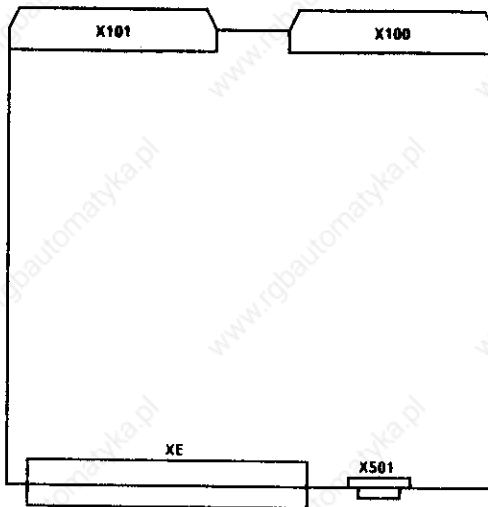

PC board C98043-A1662 (converters 15A)

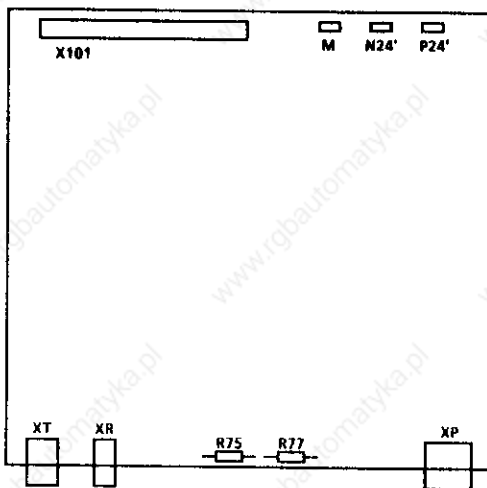

R75 and R77 are mounted on solder pins, and can be changed if the armature current has to be reduced.

PC board C98043-A1663 (converters 30 to 600A)

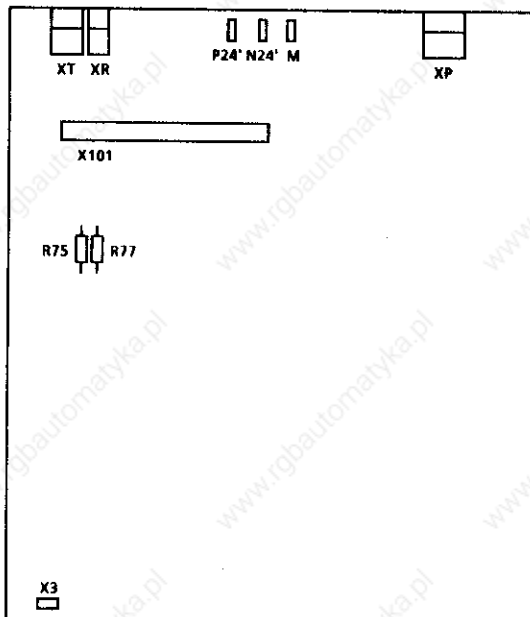

R75 and R77 are mounted on solder pins, and can be changed if the armature current has to be reduced.

6.6 Fuses and commutating reactors

6.6.1 Commutating reactors

Commutating reactors should be taken from Catalog DA93.1.

6.6.2 Fuses

Converter Order No.	Type designation	Line fuse	
		Order No.	Rated current A
6RA2318 - 6DS21	D485 / 30 Mre - GeE6S21	3NE8003	35
6RA2325 - 6DS21	D485 / 60 Mre - GeE6S21	3NE8020	80
6RA2328 - 6DS21	D485 / 90 Mre - GeE6S21	3NE8022	125
6RA2331 - 6DS21	D485 / 125 Mre - GeE6S21	3NE8024	160
6RA2375 - 6DS21	D485 / 200 Mre - GeEF6S21	3NE3225	200
6RA2377 - 6DS21	D485 / 250 Mre - GeEF6S21	3NE3227	250
6RA2381 - 6DS21	D485 / 400 Mre - GeEF6S21	3NE3233	450
6RA2385 - 6DS21	D485 / 600 Mre - GeEF6S21	3NE3336	630
6RA2318 - 6GS21	D600 / 30 Mre - GeE6S21	3NE8003	35
6RA2325 - 6GS21	D600 / 60 Mre - GeE6S21	3NE8020	80
6RA2328 - 6GS21	D600 / 90 Mre - GeE6S21	3NE8022	125
6RA2331 - 6GS21	D600 / 125 Mre - GeE6S21	3NE8024	160
6RA2375 - 6GS21	D600 / 200 Mre - GeEF6S21	3NE3225	200
6RA2377 - 6GS21	D600 / 250 Mre - GeEF6S21	3NE3227	250
6RA2381 - 6GS21	D600 / 400 Mre - GeEF6S21	3NE3233	450
6RA2385 - 6GS21	D600 / 600 Mre - GeEF6S21	3NE3336	630

Converter Order No.	Type designation	Phase fuse		DC fuse	
		Order No.	Rated current A	Order No.	Rated current A
6RA2313 - 6DV61	D420/ 15Mreq - GeG6V61	3NE8015 5SD440	25 25	3NE8015 5SD440	25 25
6RA2318 - 6DV61	D420/ 30 Mreq - GeG6V61	3NE8003	35	3NE8017	50
6RA2325 - 6DV61	D420/ 60 Mreq - GeG6V61	3NE8020	80	3NE8021	100
6RA2330 - 6DV61	D420/ 100 Mreq - GeG6V61	3NE8022	125	3NE8024	160
6RA2332 - 6DV61	D420/ 140 Mreq - GeG6V61	3NE8024	160	3NE3224	160
6RA2375 - 6DV61	D420/ 200 Mreq - GeGF6V61	3NE3225	200	3NE3227	250
6RA2377 - 6DV61	D420/ 250 Mreq - GeGF6V61	3NE3227	250	3NE3227	250
6RA2381 - 6DV61	D420/ 400 Mreq - GeGF6V61	3NE3233	450	3NE3233	450
6RA2385 - 6DV61	D420/ 600 Mreq - GeGF6V61	3NE3336	630	3NE3336	630
6RA2318 - 6GV61	D520/ 30 Mreq - GeG6V61	3NE8003	35	3NE8017	50
6RA2325 - 6GV61	D520/ 60 Mreq - GeG6V61	3NE8020	80	3NE8021	100
6RA2330 - 6GV61	D520/ 100 Mreq - GeG6V61	3NE8022	125	3NE8024	160
6RA2332 - 6GV61	D520/ 140 Mreq - GeG6V61	3NE8024	160	3NE8024	160
6RA2375 - 6GV61	D520/ 200 Mreq - GeGF6V61	3NE3225	200	3NE3227	250
6RA2377 - 6GV61	D520/ 250 Mreq - GeGF6V61	3NE3227	250	3NE3227	250
6RA2381 - 6GV61	D520/ 400 Mreq - GeGF6V61	3NE3233	450	3NE3233	450
6RA2385 - 6GV61	D520/ 600 Mreq - GeGF6V61	3NE3336	630	3NE3336	630

Recommended field fuses

Converter rated DC current A	Max. permissible field current A	Fuse Order No.	Rated current of the fuse A
15	3	5SD420	16
30	5	5SD420	16
60 to 140	10	5SD420	16
200 to 250	15	5SD440	25
400 to 600	25	5SD440	25

6.7 Terminal connecting diagram (for 15A converters)

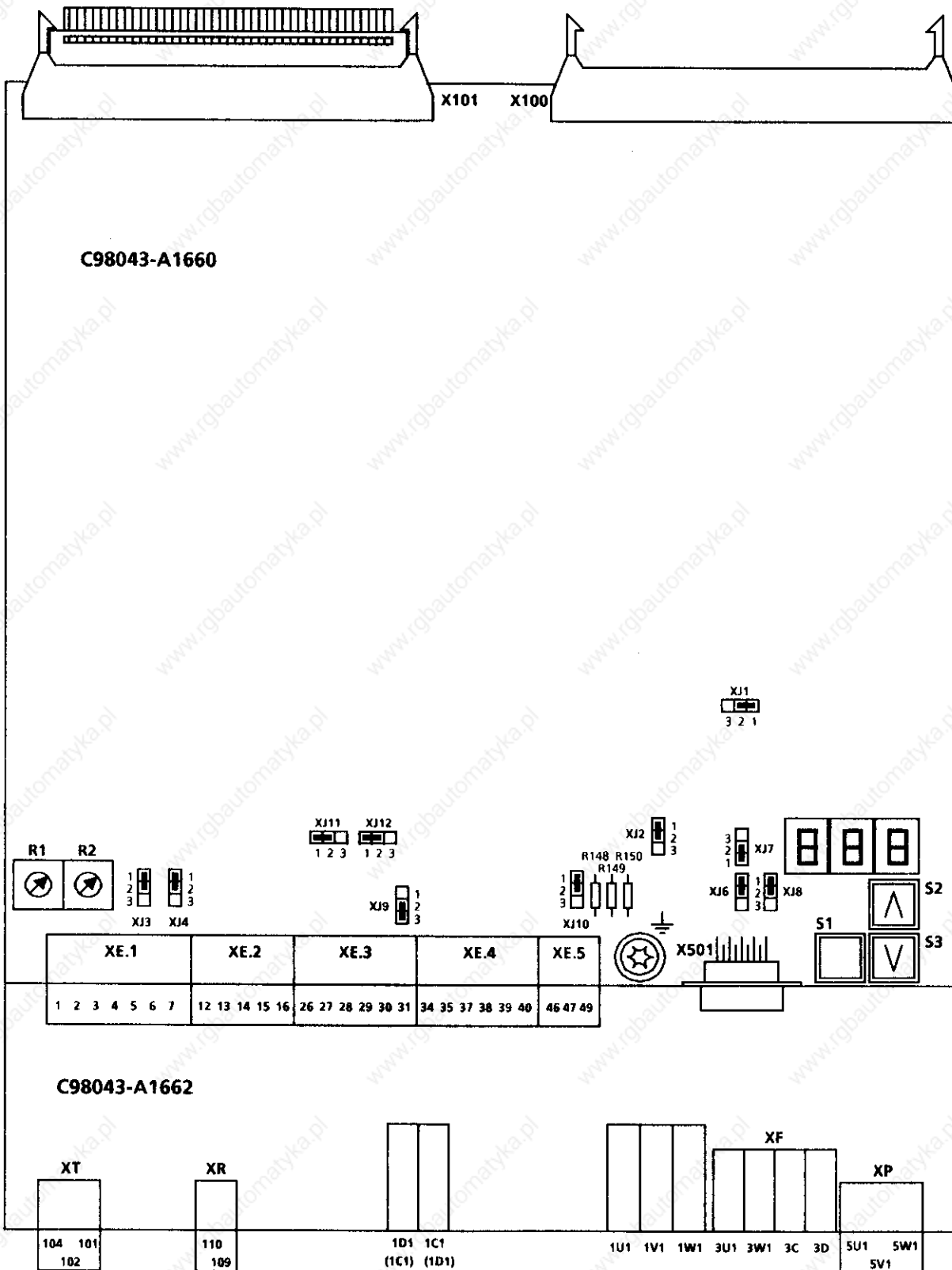

Terminal connecting diagram (for 30A to 600A converters)

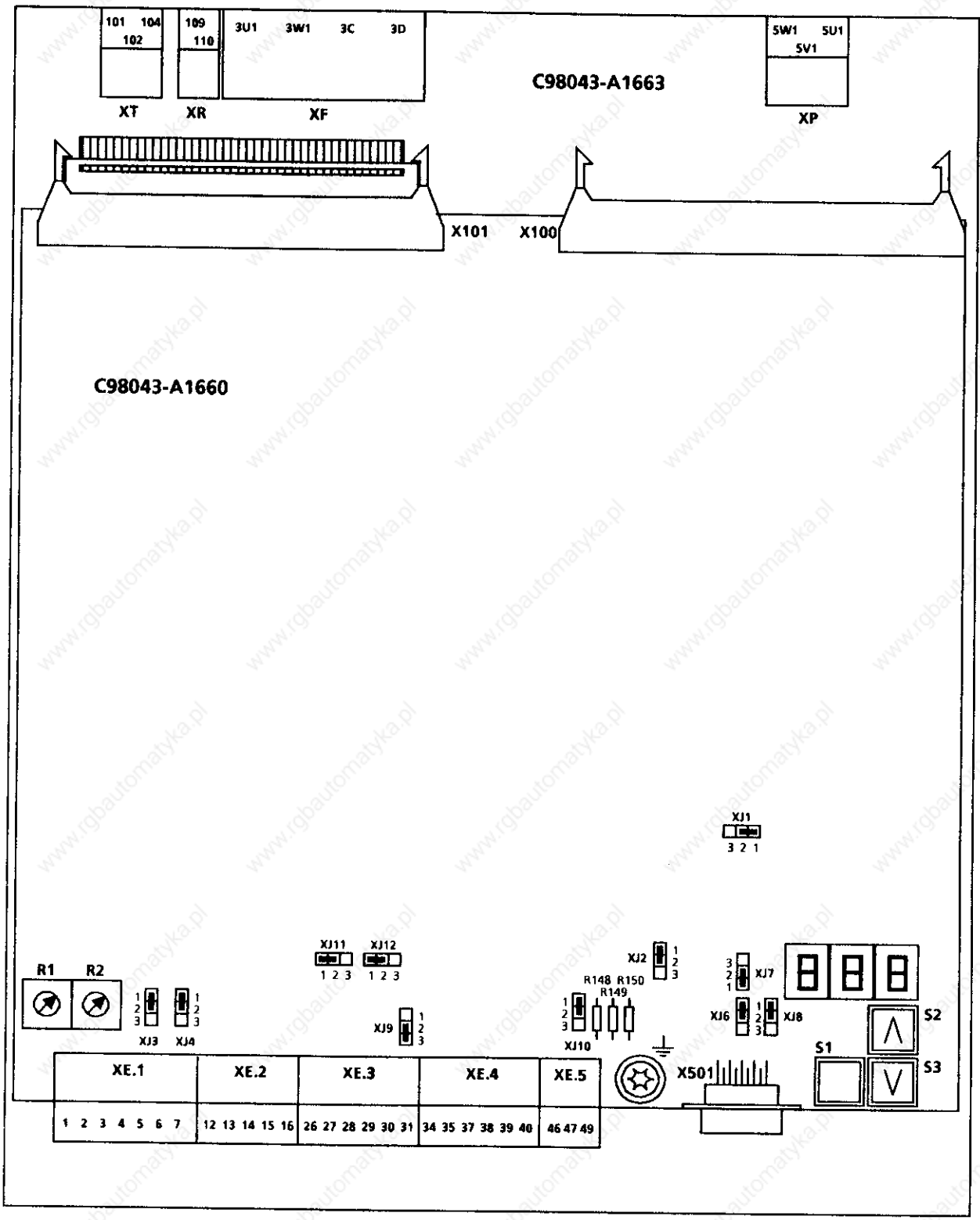

6.7.1 Settings

Electronics PC board, C98043-A1660

Pin 1 of the plug-in jumpers is labelled.

Plug-in jumper XJ1 Write signal for the EEPROM interrupted (hardware write protection)
 Position 1-2: Write active (as supplied)
 Position 2-3: Write de-activated (darf nur bei gleichzeitig aktiviertem Software-Schreibschutz eingelegt werden, siehe Parameter P87)

Plug-in jumper XJ2 5V power supply for the interface expansion option (C98043-A1618)
 Position 1-2: Interface is not supplied (as supplied)
 Position 2-3: Interface is supplied

Plug-in jumper XJ3 Load resistor (300 Ω) for the speed setpoint (main setpoint)
 Position 1-2: 0 to $\pm 10V$ (as supplied)
 Position 2-3: 0 to $\pm 20mA$

Plug-in jumper XJ4 Gain adaption for the speed setpoint (main setpoint)
 Position 1-2: 0 to $\pm 10V$ (as supplied)
 Position 2-3: 0 to $\pm 20mA$

Plug-in jumpers XJ3 and XJ4 must always have the same position!

Plug-in jumper XJ6 Transmit signal for the interface expansion option (C98043-A1618)
 Position 1-2: Signal is not fed to connector X501 (as supplied)
 Position 2-3: Signal is fed to connector X501

Plug-in jumper XJ7 Receive signal for the interface expansion option (C98043-A1618)
 Position 1-2: Signal is not fed to connector X501 (as supplied)
 Position 2-3: Signal is fed to connector X501

Plug-in jumper XJ8 Control signal (driver enable) for interface expansion option (C98043-A1618)
 Position 1-2: Signal is not fed to connector X501 (as supplied)
 Position 2-3: Signal is fed to connector X501

Plug-in jumper XJ9 Ground M5/2 for binary inputs connected with internal ground M
 Position 1-2: Not connected
 Position 2-3: Connected (as supplied)

Plug-in jumper XJ10 24V power supply for binary outputs
 Position 1-2: Supply with internal P24 (as supplied)
 Position 2-3: Supply with external P24 via terminal 49 w.r.t. M (ground terminal 47)

Plug-in jumper XJ11 Pulse encoder, track 1, level changeover
 Position 1-2: 15V rated voltage (as supplied)
 Position 2-3: 5V rated voltage

Plug-in jumper XJ12 Pulse encoder, track 2, level changeover
 Position 1-2: 15V rated voltage (as supplied)
 Position 2-3: 5V rated voltage

Plug-in jumpers XJ11 and XJ12 must always have the same position!

Pushbutton S1 Parameter mode changeover

Pushbutton S2 RAISE parameter

Pushbutton S3 LOWER parameter

Potentiometer	R1	Rough tachometer adjustment
Potentiometer	R2	Fine tachometer adjustment

R148, R149 and R150 0Ω resistors, connection M-ground
 When supplied, M is connected to ground. These resistors are only removed to prevent disturbances as a result of ground loops, i.e. if the electronics ground is connected to ground in a different fashion (e.g. through signal cables).
 Example: Signal ground grounded at the NC control and connected with signal terminals on the converter

Interface expansion PC board C98043-A1618 (option)

Pin 1 of the plug-in jumpers is labelled.

Plug-in jumper XJ200	RS485 bus termination Position 1-2: Bus (X502.8) is terminated (390Ω) after M5 (X502.5) Position 2-3: No bus termination (as supplied)
Plug-in jumper XJ201	RS485 bus termination Position 1-2: No bus termination (as supplied) Position 2-3: Bus is terminated (X502.3 is connected to X502.8 through a 150Ω resistor)
Plug-in jumper XJ202	RS485 bus termination Position 1-2: Bus (X502.3) is terminated (390Ω) after P5 (X502.6) Position 2-3: No bus termination (as supplied)

6.8 Terminal assignment



WARNING

The converter could be damaged or destroyed if connected incorrectly.

Power section

15A converters

30A converters

60A converters

90A to 250A converters

400A converter

600A converter

Terminal type:

PC board terminal (2.5mm² cross-section, finely-stranded wire)Screw terminal (10 mm² cross-section, finely-stranded wire)Screw terminal (16 mm² cross-section, finely-stranded wire)

1U1,1V1,1W1: M8 nut (3x20 copper bus)

1C1,1D1: M10 nut (4x25 copper bus)

1U1,1V1,1W1: M10 nut (3x30 copper bus)

1C1,1D1: M10 nut (3x40 copper bus)

1U1,1V1,1W1: M10 nut (5x30 copper bus)

1C1,1D1: M10 nut (5x40 copper bus)

Function	Terminal	Connected values/comments
Armature supply input	1U1 1V1 1W1	Refer to technical data, Section 3.4
Protective conductor PE		
Armature circuit-motor connection	1C1 (1D1) 1D1 (1C1)	

Electronics power supply

Terminal type: MSTB2.5 plug-in terminals
maximum cross-section, 1.5mm²

Function	Terminal XP	Connected values/comments
Supply	5U1 5V1 5W1	3-ph. 400 (+ 15% / -20%); I _n = 60mA 50Hz to 60Hz

NOTE

The power section and electronics power supply must be connected with the same phase sequence.

For supplies, other than 400 V, an appropriate matching transformer must be used between 1U1, 1V1, 1W1 and 5U1, 5V1, 5W1.

The phase failure monitoring is derived from the electronics power supply transformer. In order to be able to identify phase failure, even when a power section fuse blows, the electronics power supply must be connected after the power section fuses (i.e. on the converter side).

Supplementary supplyTerminal type: Faston lugs 6.3 x 0.8 mm

Function	Terminal	Connected values/comments
Supplementary supply, also refer to Section 10.15	P24' N24' M	+ 24V / 1A - 24V / 300mA

NOTE

Insulated Faston connectors are required for the supplementary supply on the power supply!

Ground loops should be prevented when supplying several converters!

Field circuitTerminal type:

15A converter

Printed circuit board term., max. 2.5mm² cross-section, finely stranded

30A to 600A converters

G6/6 G6/4 converter terminal (screw terminal)
maximum cross-section, 4mm²

Function	Terminal XF	Connected values/comments
Supply connection	3U1	2AC max.400 (+ 15%)
Field connection	3W1 3C 3D	Rated DC voltage 340V

Fan (for force-cooled converters $\geq 200A$)Terminal type: G6/4 converter terminal (screw terminal)
maximum cross-section, 4mm²

Function	Terminal	Connected values/comments
Supply	4U1 4V1 4W1	for converters 200A to 600A: 3-ph. 400 (\pm 15%); 0,18A; 90W 50Hz to 60Hz
Protective conductor PE		

**WARNING**

The converter might overheat if the incorrect phase sequence is connected (incorrect fan direction of rotation)

Test: Optically check that the fan rotates in the direction indicated by the arrow!

Caution: Danger of injury due to rotating parts!

Open-loop and closed-loop control section

Terminal type: MSTB2.5 plug-in terminals
maximum cross-section, 1.5mm²

Analog inputs - setpoint inputs, reference voltage

Function	Terminal XE	Connected values/comments	Possible settings	
Reference M P10 N10	1 2 3	} $\pm 1\%$ at 25°C (stability 0.5% per 10°K); 4mA short-circuit proof		
Main setpoint Main setpoint Caution: Terminal 5 must be connected when using this select input!	4 5		Differential input XJ3, XJ4 - position 1-2: $\pm 10V$; 515k Ω Resolution: approx. 2,4mV XJ3, XJ4 - position 2-3: 0 - 20mA; 300 Ω (polarity reversal via the binary select input) Common mode control range: $\pm 20V$	XJ3 XJ4 E01
Analog select input Analog select input Caution: Terminal 7 must be connected when using this select input!	6 7		Differential input $\pm 10V$; 515k Ω Resolution: approx. 2,4mV Common mode control range: $\pm 20V$	E02 P85

Analog inputs - speed actual value inputs, tachometer inputs

Function	Terminal	Connected values/comments	Possible settings
Tachometer connection	101 102	$\pm 250V$; 70.7k Ω $\pm 25V$; 12.7k Ω	R1 R2
Tachometer ground	104		

Pulse encoder input

Function	Terminal XE	Connected values/comments	Possible settings
Supply (+ 13V to + 18V)	26	150mA; short-circuit proof via PTC	
Ground, pulse encoder M5/1	27		
Track 1 ²⁾ Positive supply	28	Load: $\leq 5mA$ at 15V (w/o switching losses, refer below Cable, cable length, screen connection Switching hysteresis refer below Mark-to-space ratio: 1:1	XJ11
Negative supply	29		XJ12
Track 2 Positive supply	30		P53
Negative supply	31		to P59

1) In the closed-loop speed control mode, when motoring, a positive converter output voltage (from terminal 1C to 1D) and a positive output current at terminal 1C (torque direction I) a negative setpoint (terminal 4 negative with respect to terminal 5) and a positive speed actual value are required (terminals 101 and 102 with respect to tachometer ground, terminal 104).

In the closed-loop current control mode a positive output current is required at terminal 1C (torque direction I), and a positive setpoint (terminal 4 positive with respect to terminal 5).

It is possible to reverse the polarity via parameter E01 = - 100.

2) When using the pulse encoder input, the negative terminal, term. 29 and 31 must be wired-up (or terminal 29 and terminal 33).

Characteristic values of the pulse encoder evaluation electronics

Input pulse level:

Encoder signals (symmetrical and unsymmetrical) up to a max. 27 V differential voltage can be processed by the evaluation electronics. The evaluation electronics must adapt the encoder signal voltage via plug-in jumpers XJ11, XJ12 and XJ13. Two rated voltage ranges are defined using the plug-in jumper setting:

- **5V** nominal voltage range with plug-in jumpers XJ11, XJ12 and XJ13 in position 2-3:
(for pulse encoders with 5 V power supply, an external power supply is required):
Low level: Differential voltage < 0.8V
High level: Differential voltage > 2.0V
Hysteresis: > 0.2V
Common-mode control range: $\pm 10V$
- **15V** nominal voltage range with plug-in jumpers XJ11, XJ12 and XJ13 in position 1-2:
Low level: Differential voltage < 5.0V
High level: Differential voltage > 8.0V Restriction: refer to the switching frequency
Hysteresis: > 1V
Common-mode control range: $\pm 10V$

If the pulse encoder does not provide symmetrical signals, then its ground should be fed as twisted pair in each signal cable, and should be connected with the negative connections of track 1, track 2 and the zero mark.

Switching frequency:

The maximum encoder pulse frequency is 300 kHz. In this case, in order that the encoder pulses are correctly evaluated, the minimum distance T_{min} between two encoder signal edges (track 1, track 2), specified in the table, should be maintained.

Table 1:

	5V rated voltage		15V rated voltage		
Differential voltage ¹⁾	2V	> 2.5V	8V	10V	> 14V
T_{min} ²⁾	630ns	380ns	630ns	430ns	380ns

- 1) Differential voltage at the terminals of the evaluation electronics
- 2) The phase error L_G (deviating from 90°), which can occur due to the encoder and cable, can be calculated from T_{min} :

$$L_G = \pm (90^\circ - f_p \times T_{min} \times 360^\circ \times 10^{-6})$$

L_G [°] = Phase error

f_p [kHz] = Pulse frequency

T_{min} [ns] = Minimum distance between edges

This formula is only valid if the mark-to-space ratio of the encoder signals is 1:1.

Note: Noisy encoder signal edges (encoder pulse oscillations) can result in incorrect pulse evaluation and thus faults/errors!

Cable, cable length, screen connection:

The encoder cable capacitance must be recharged at each encoder edge change. The RMS value of this current is proportional to the cable length and the pulse frequency, and must not exceed the current specified by the encoder manufacturer. A suitable cable, recommended by the encoder manufacturer should be used, and the maximum cable length should not be exceeded. Generally, a twisted cable pair with common pair screening is sufficient for each track. Crosstalk between the cables is thus reduced. The screening of all pairs protects against noise pulses. The screen should be connected to the screen bar of the SIMOREG converter with the largest possible surface area.

Analog outputs

Function	Terminal XE	Connected values/comments	Possible settings
Current act. value Ground, analog M	12 13	0... ± 5V corresponds to 0... ± 100% rated converter current max. load 2mA, short-circuit proof	P86
Select output, analog 1 Ground, analog M	14 15	0... ± 10V, max. 2mA, short-circuit proof, resolution ± 8bit	P35 P36
Select output, analog 2 Ground, analog M	16 15	0... ± 10V, max. 2mA, short-circuit proof, resolution ± 8bit	P37 P38

Binary control- and select inputs

**WARNING**

When energizing the binary control- and select inputs from an external voltage source, which is not referred to the converter ground (XJ9 in position 1-2), the potential difference between the converter ground and ground of the external voltage must not exceed 50 V (otherwise the optocouplers could be damaged).

Function	Terminal XE	Connected values/comments	Possible settings
Supply Ground for binary inputs	34 44 35	24V DC, max. load 50mA, internal supply referred to internal ground can be disconnected from int. ground (disconnected ⇒ XJ9 in position 1-2)	XJ9
Switch-on/shutdown	37	H signal: Switch-on ⁴⁾ Line contactor ON H signal at terminal 38 accelerate along the ramp-function generator ramp up to operating speed. L signal: Shutdown ⁴⁾ Deceleration along the ramp-function generator ramp to $n < n_{min}$ (P21), then controller inhibit and line contactor OUT	
Enable signal	38	H signal: Controller enabled ⁴⁾ L signal: Controller inhibited ⁴⁾ The L signal acts as higher-level signal on "inching" and "crawl". (precise function description, refer to Section 10.2 "binary input functions").	
Select input binary 1	39	refer to Section 10.2 "binary input functions" ⁴⁾	P83
Select input binary 2	40	refer to Section 10.2 "binary input functions" ⁴⁾	P84

4) H signal: + 13V to + 33V
L signal: - 3V to + 5V or terminal open } for binary control inputs
8.5mA at 24V

Binary select output

Function	Terminal XE	Connected values/comments	Possible settings
External supply for binary select output	49	24V DC supply (20V - 30V) (plug-in jumper XJ10, position 2-3)	XJ10
Ground M for binary select output	47		
Select output binary	46	Internal supply: H signal Max. load, 10mA. External supply: H signal: 20V to 30V Max. load, 80mA.	P80

Relay output

Function	Terminal XE	Connected values/comments
Relay K3 for line contactor, common	109	Contact loading capability: ≤ 240V AC, 3A; $\cos\Phi = 1$ ≤ 240V AC, 1A; $\cos\Phi = 0,3$ ≤ 100V DC, 3A
Relay K3 for line contactor, NO contact	110	

**RS232 serial interface (9-pin SUBMIN D socket connector)
(G-SST1)**

Use a screened cable! Ground screen at both ends!

Function	Terminal	Connected values/comments	Possible settings
RxD1_1 if XJ7 in position 2-3	X501.1	Connection to interface expansion option	P97
Received data RxD	X501.2	RS232 interface	
Transmitted data TxD	X501.3	RS232 interface	
TxD1_1 if XJ6 in position 2-3	X501.4	Connection to interface expansion option	XJ2 XJ6 XJ7 XJ8
Signal ground	X501.5	Ground for RS232 interface	
DE2_1 if XJ8 in position 2-3	X501.6	Direction changeover for interface expansion option	
Driver output	X501.7	RTS (request to send)	
Driver input	X501.8	CTS (clear to send)	
P5_10 if XJ2 in position 2-3	X501.9	+ 5V supply for interface expansion option	

Activating the RS232 interface:

- Setting the transmission rate using parameter P97, one's location.
- Setting the protocol (and if required, also the desired function) at parameter P97, hundred's location.
- If parameter P97 was set to 0xx, then the required function must still be selected and started using parameter P51.

Option:**Interface expansion (C98043-A1618-L1) Order No.: 6RX1240-0AL01**

RS485 serial interface (9-pin SUBMIN D socket connector)
(G-SST1)

Use a screened connecting cable! Ground screen at both ends!

The bus is terminated at the ends of the bus cable using plug-in jumpers XJ200, XJ201 and XJ202.

Function	Con. pin	Connected values/comments	Possible settings
Free	X502.1		P97
Free	X502.2		
RxD_P1 or RxD / TxD_P1	X502.3	For four-wire or two-wire cables	
TxD_P1	X502.4	Only for four-wire cables	XJ200 XJ201 XJ202
DGND	X502.5	Ground	
+ 5V supply	X502.6	VP for cable termination	
Free	X502.7		
RxD_N1 or RxD / TxD_N1	X502.8	For four-wire or two-wire cables	
TxD_N1	X502.9	Only for four-wire cables	

Cable length: max. 1200m

The following must be observed: DIN 19245, Part 1

It is important that the potential difference between the data reference potentials DGND of all interfaces does not exceed $\pm 7V$. If this cannot be guaranteed, potential equalization must be provided.

7 Start-up

7.1 General safety information for start-up

NOTE

Before starting-up the converter, it should be checked that the converter software (D17, D18) is inserted on PC board A1660.

Before touching any board (especially the A1660 electronics board), the operator must discharge himself electrically, in order to protect the electronic components from high voltages, generated as a result of electrostatic charging. This can be easily realized by touching a conductive, grounded object immediately beforehand (e.g. bare metal cubicle components).

Boards must not come into contact with highly-insulating materials (e.g. plastic foils, insulating desktops, clothing articles manufactured from man-made fibers).

Boards must only be placed on conductive surfaces.



WARNING

This converter contains hazardous voltages and rotating mechanical components (fans). Death, severe bodily injury and material damage can occur if the instructions in this Manual are not observed.

A hazardous voltage can be present at terminals 108 and 110 on the customer's side.

The converters **MUST NOT** be connected to a supply with earth-leakage circuit-breaker (VDE 0160, Section 6.5) as a DC component can be included in the fault current when a fault to frame or ground occurs, which either prevents or hinders a higher-level earth-leakage circuit-breaker from tripping. In this case all loads connected to this earth-leakage circuit-breaker also have no protection.

Only qualified personnel who are familiar with all of the safety instructions contained in this Manual and all installation, operating and maintenance instructions can work on the equipment.

This converter must be professionally transported, stored, installed and mounted and carefully operated and serviced to ensure perfect, safe and reliable operation.

The converter is at a hazardous voltage level even when the converter line contactor is open. The gating board (the board mounted directly in the lower part of the housing) has many circuits at hazardous voltage levels. Before carrying-out any service or maintenance work, disconnect ALL power sources from the converter supply and lock-out.

This Manual does not claim to list all of the measures required to ensure safe and reliable operation of the converter. For special applications, additional, supplementary information or instructions might be required. If problems do occur and you feel in any way uncertain, please contact your local Siemens office or representative.

Death, severe personal injury or significant material damage can occur if non-authorized parts and components are used to repair/service this equipment or if unqualified personnel handle it. All of the safety instructions in this manual and all warning labels on the equipment itself must be observed.

Please observe all warning notes in section 1 of this Manual.



7.2 Operator control panel

The basic converter should be controlled with the parameterizing unit described in the following. The necessary adaptations, settings and measurements, required for start-up can thus be executed.

7.2.1 Parameterizing unit

The parameterizing unit is located at the right below the converter door cover and consists of a 3-digit, 7-segment display and 3 keys for parameterization.

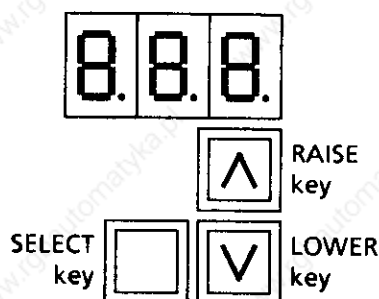

- **SELECT key**
 - Changes over between the parameter number (parameter mode) and parameter value (value mode)
 - Accelerates the rate of change initiated by the RAISE or LOWER key
 - Fault acknowledgement
- **RAISE key**
 - Selects a higher parameter number in the parameter mode
 - Increases the selected and displayed parameter value in the value mode.
 - Starting a function selected using parameter P51 (e.g. optimization run)
- **Lower key**
 - Selects a lower parameter number in the parameter mode
 - Decreases the selected and displayed parameter value in the value mode.
 - Terminates a function selected using parameter P51 (e.g. optimization run)

7.3 Procedure when parameterizing

Parameterizing means changing parameter values and activating converter functions using the operator control panel. For display, parameters are sub-divided into P-, E-, D-, H- and L-parameters.

Parameter types

Display parameters are used to display actual quantities, such as e.g. main setpoint, armature voltage, setpoint-actual value difference of the speed controller etc. The parameter values of display parameters can only be read, and cannot be changed using parameterization.

Decimal parameters are used to display decimal values, such as e.g. rated motor current, thermal motor time constant, speed controller P gain etc., and they can also be changed using parameterization.

Hexadecimal parameters are used to display and to change using parameterization, values, such as e.g. control words for the converter control, control word for the pulse encoder, protocol selection for an interface etc. In this case, each digit has its own meaning.

Special parameters are used to display, in a special form, values such as the operating status, the status of the binary inputs and outputs, limits etc.

Parameterization

1. Select the parameter number of the parameter to be changed.
If required, change over into the parameter mode by depressing the SELECT key, whereby the actual parameter number is displayed on the 7-segment display.
Select the required parameter number by depressing the RAISE or LOWER KEY.
The selected parameter number "P x x" is then displayed.
2. Change over into the value mode by depressing the SELECT key, so that the current parameter value is displayed.
3. Change the parameter value by depressing the RAISE or LOWER key.

CAUTION! Parameter changes are only possible under the following conditions:

- The appropriate access authorization is set at key parameter P51, e.g. "20" (refer to Section 9.2 "Parameter Description").
- The converter is in the appropriate operating status. Parameters, with the characteristic "offline" cannot be changed in the "run" operating status (online). To change, go into the "ready to run" status.

The new parameter value of the selected parameter is then displayed.

4. To select the next parameter to be changed, or to prevent erroneous parameter value change, change over into the parameter mode by depressing the SELECT key..

NOTE: A parameter number can be selected or a parameter value changed ten times faster by using the RAISE or LOWER key and simultaneously depressing the SELECT key.

For some critical parameters, this accelerated rate of change of parameter values is inhibited in the RUN status (online)! These values can only be changed slowly. All parameter values can be quickly changed in the READY TO RUN status (offline).

List of all the possible operating panel displays

Display	Significance
	Refer to operating statuses, Section 8.1
to	
	Refer to operating statuses, Section 8.1
	No torque direction requested
	Torque direction I
	Torque direction II
	Controller and setpoint limiting (P00) (refer to Section 8.1)
	P mode
	W mode
	Display of logical statuses (P15) (refer to Section 9.2)
	Fault messages
	Prompt to depress key (optimization run)
	Activation display (optimization run)
	Diagnostics monitor
	Analog diagnostic function

7.4 Establish factory setting

The "establish factory setting" must be carried-out if the converter software was changed.

The "reset to default" can be executed if a defined basic setting is to be established, e.g. in order to carry-out a complete new start-up.

NOTE

All system-specific set parameters are overwritten (deleted) with "reset to default". It is therefore recommended that all of the old settings are printed-out with **P51 = 30**, or stored in the PC or PG with **P51 = 31**, prior to carrying-out "reset to default". If the "establish factory setting" is executed, then the complete start-up must be carried-out, as the unit cannot be operated for safety units.

NOTE

The "establish factory setting", function can only be executed if there is no hardware write protection. Plug-in jumper XJ1 must be in the 1-2 setting (as supplied).

Execution:

- 1) Switch-in the electronics power supply 5U1, 5V1, 5W1
- 2) Set P51 to 20
- 3) Set P87 to 3x
Thus, the parameter settings, made in the following point, are also saved in the EEPROM
- 4) Set the following parameters manually to the required values (refer to Section 9.2 "Parameter Description")
P93: Rated supply voltage/output (rating plate)
P98: Voltage adaption for the electronics power supply
E00: Equipped options
- 5) Select P52, change over to the value mode, and depress the raise or lower key.
- 6) Switch-off the electronics power supply 5U1, 5V1, 5W1 for at least 2 s, and then switch-on again.
Operating status o7 appears.

The electronics power supply must remain switched-on for at least 15 s in order to correctly complete the "establish factory setting" function. Only then are parameter values stored in the EEPROM. Key parameter P51 again has the value "0". Parameter changes are no longer possible in this status.

The following pre-set parameters are not changed by "establish factory setting": P93, P98 und E00.

NOTE

For "establish factory setting" parameter P87 is also set to the initial status (33). Also refer to P87 in Section 9.2 "Parameter Description".

7.5 Start-up steps



WARNING



This converter has hazardous voltage levels, even when the converter line contactor is open. The gating board (the lower PC board mounted directly on the housing) has many circuits at hazardous voltage levels.

Death, severe bodily injury and material damage can occur if the instructions specified in this Instruction Manual are not observed.



1 Check the plug-in jumpers

NOTE

The plug-in jumpers must only be changed with the electronics power supply switched-off!

Refer to Section 6.7 "Terminal connecting diagram" and Section 6.7.1 "Settings" for location and setting of the plug-in jumpers when the equipment is supplied.

The plug-in jumpers should be inserted according to the relevant circuit-diagrams and the required functions.

Plug-in jumper XJ1 on board A1660 must be in the 1-2 position (no hardware write protection for the parameter memory).



2 Adapting the rated converter currents (if required)

NOTE

It is only permissible to adapt the load resistor when the converter has been completely shutdown and disconnected (both the electronics power supply and power section in a no-voltage condition)!

The **rated converter armature current** must be adjusted by removing the armature load resistors, if:

$$\frac{\text{max. armature current}}{\text{rated converter armature current}} < 0.5$$

The rated converter armature current can be reduced to $\frac{2}{3}$ or $\frac{1}{3}$ of the rated converter current by removing the armature load resistors.

Refer to Section 6.5 "load resistors" for detailed information about the reduced rated currents.

3

Shutdown, i.e. terminal 37 open
Inhibit operating enable, i.e. open terminal 38



WARNING

Operation enable is not permissible up to start-up step 13 (terminal 38 opened).

4

Three-phase monitoring

The electronics power supply (5U1, 5V1, 5W1) should be checked to see that it has the same phase sequence as the power connections (1U1, 1V1, 1W1).

Check for clockwise rotation field

NOTE

The converter identifies an incorrect phase assignment and sequence, which results in fault message F84 or F02 (refer to Section 8.2 "Fault Messages").

5

Parameter changes

Parameters can only be changed with the appropriate access authorization, set in key parameter P51. Parameter changes are only transferred into the non-volatile EEPROM memory, if the hardware write protection is de-activated and there is no software write protection (refer to Section 9.2, "Parameter Description").

P51 = 20 (All parameters can be changed)

P87 = 33 (Every parameter change is immediately transferred into the EEPROM)

6

Voltage adaption for the electronics power supply

P98 = $400 \times \ddot{u}$ (refer to Section 9.2 "Parameter Description")

P98 = 400 (the electronics power supply is supplied from a 400 V supply without matching transformer)

7

Motor data input

P71 Rated motor current/rated converter current ratio (0 to 100% of I_{rated})

P70 Thermal time constant for the motor I^2t monitoring



Information regarding speed actual value sensing

Selecting the speed actual value source and setting the maximum speed

Enter into parameter P53



8.1 Operation with analog tachometer P53 = 0

Check tachometer connection:

Terminal 101	range 45V to 250V
Terminal 102	range 8V to 45V
Terminal 104	Tachometer ground



8.2 Operation with pulse encoder P53 = 1

Set pulse encoder data:

P54	Pulse encoder, type
P55 and P56	Pulse encoder, pulse number
P57	Pulse encoder, control word
P58 and P59	Maximum speed



8.3 Operation without tachometer (EMF closed-loop control) P53 = 2

Enter parameters:

E33	IxR compensation
E34	Max. speed
P20	Actual value filtering
Recommended value: P20 = 40 [ms]	



Field data



9.1 Non-controlled field

Check the field power supply
Externally set the motor field current



9.2 Controlled field

These settings must only be made when an external controlled field converter is used.

The field current setpoint is output via one of the two analog select outputs (terminal 14 or 16).

- Assign terminal function
P35 = 12 (terminal 14) or P37 = 12 (terminal 16)
- Set the field current setpoint (P76)
10V setpoint corresponds to P76 = 100
E11 and P76 (terminal 14) or E12 and P76 (terminal 16)
- Define the setpoint polarity with E11 (terminal 14) or E12 (terminal 16)
E11 or E12 = 1.0 positive setpoint
E11 or E12 = -1.0 negative setpoint

(parameters E11, E12 from software release 4.0, for software release 1.0, parameters P36, P38)

e.g. the field current setpoint is output at terminal 14.

The field converter requires -6.5V for $I_{\text{field}} = 100\%$.

→ P35 = 12

P36 = -1.0 (for software release 1.0)

E11 = -1.0 (from software release 4.0)

P76 = 65

NOTE

The field current setpoint is only output at the analog select output (refer to parameter P88), after switch-on (terminal 37).



10 Parameterizing the binary and analog inputs and outputs, if required (refer to the terminal block wiring on the converter)



10.1 Analog select outputs

Terminal 14 Analog select output 1
 Set P35 and P36 (for software release 1.0)
 Set P35 and E11 (from software release 4.0)

Terminal 16 Analog select output 2
 Set P37 and P38 (for software release 1.0)
 Set P37 and E12 (from software release 4.0)



10.2 Binary select output

Terminal 46 Binary select output
 Set P80

NOTE

The permissible loading is dependent on the setting of plug-in jumper XJ10:

Position 1-2: max. 10mA

Position 2-3: max. 80mA (external supply)



10.3 Analog select input

Terminals 6 and 7 Analog select input
 Set P85



10.4 Binary select inputs

Terminal 39 Binary select input 1
 Set P83

Terminal 40 Binary select input 2
 Set P84



10.5 Current actual value

Terminal 12 I_{act}
 Set P86

11 Select basic technological functions

11.1 Current limits

- P39 System current limit in torque direction I
- P40 System current limit in torque direction II

11.2 Torque limits

- E68 Torque limit 1 in torque direction I and II

11.3 Ramp-function generator

- P16 Acceleration time 1
- P17 Deceleration time 1
- P18 Initial rounding-off 1
- P19 Final rounding-off 1

12 Selecting the operating mode for restart and fault acknowledgement

Set P87

13 Rough tachometer adjustment (if an analog tachometer is used)

- ### 13.1
- Rotate potentiometer R1 to its lefthand endstop (rough)
 - Set potentiometer R2 to its center position (fine)

- ### 13.2
- Select P01 (n_{set} display), changeover into the value mode, and using the speed setpoint, adjust a value close to "0" (terminals 4 and 5).

13.3



WARNING

The drive will start when controller enable is issued!

Switch-on via terminal 37, and enter operating enable via terminal 38.

- ### 13.4
- Increase the setpoint until "10.0" is displayed for P001.

- ### 13.5
- Adjust 10% of the rated speed using potentiometer R1 (rough) and R2 (fine). The motor speed can be determined using a handheld tachometer or by measuring the tachometer voltage.

- ### 13.6
- Set setpoint to "0", shutdown (terminal 37) and inhibit the operating enable (terminal 38).



Execute optimization runs

For many applications, it is sufficient to set the controller parameters using the automatic optimization run. The drive should be manually optimized, according to Section 7.6, if the drive has to fulfil increased requirements regarding control- and dynamic performance.

NOTE

The drive must be optimized in the following sequence:

- Optimization run for pre-control, current controller and internal adjustments (start-up step 14.1)
- Optimization run for the speed controller (start-up step 14.2)

The determined parameters are dependent on the motor temperature. The automatically selected values for the motor in the cold state can be used as a good pre-setting.

For dynamic, high-performance drives, optimization step P51 = 25 should be repeated after the drive has been operated under load (i.e. with the motor warm).

Execution:

- 1) The drive must be in operating status o7 or higher (issue SHUTDOWN)
- 2) Select the optimization run using key parameter P51
- 3) Switch-on via terminal 37 and enter operating enable via terminal 38
- 4) The prompt to depress the key OP⁺ is displayed
Depressing the RAISE key signifies: YES!
Depressing the LOWER key signifies: NO!
Operating status o7 is displayed once the optimization run has been completed
- 5) Set the setpoint to "0"
Shutdown (terminal 37) and inhibit operating enable (terminal 38)



Optimization run for pre-control, current controller and internal adjustments



WARNING



Approximately 80% of the rated motor current, set using P71, flows during the current controller optimization run.

NOTE

For a controlled field (using an external field converter), the field current is automatically adapted to the optimization run by entering the field current setpoint (current controller optimization run as well as speed controller optimization run).

- Disconnect the motor field current (terminals 3U1, 3W1)
- Call-up with **P51 = 2**
Duration up to 1 min.

Parameters P64 to P68 and L34 are set.

NOTE

The motor must be at a complete standstill if the optimization run of the feed-forward control and the current controller. If the motor starts to drift as a result of the residual motor field during the optimization run, this is identified, and signaled with fault message F32. Optimization is then not executed. This monitoring function is not provided for operation with tachometer (selected with P53 = 2-EMF actual value as speed actual value). Thus, especially in this case, it should be ensured that the motor is locked so that it cannot rotate.



Speed controller optimization run



WARNING

The drive rotates with approx. 6% of the maximum speed during the speed controller optimization run.

- Switch-on the motor field current (terminals 3U1, 3W1)
- Call-up with **P51 = 3**
Duration approx. 1 min.

NOTE

Optimize the drive with the motor connected. If a 2nd gearbox stage is used, repeat the optimization run with the 2nd gearbox stage selected (activated binary select input P83 or P84 = 24).

Parameters P31, P32 and/or P33, P34 are set, for selected gearbox stage II.



Fine tachometer adjustment (if an analog tachometer is used)



If the field is supplied from an external field converter (e.g. to permit field weakening), set P77 and P90.

P77 = EMF setpoint, whereby: $P77 = V_{AN} - I_{AN} \times R_A$
 V_{AN} = rated armature voltage
 I_{AN} = rated armature current
 R_A = armature resistance (warm)

P90 = 2

NOTE

If the rated speed can only be reached by field weakening, when finely adjusting the tachometer, the speed setpoint must only be slowly increased, as the field control circuit has still not been optimized!

15.2

Select P01 (display n_{set}), changeover into the value mode, and set "0" using the speed setpoint (terminals 4 and 5).



WARNING



When making the following adjustments, the drive accelerates up to rated speed!

If the setpoint is changed too quickly in the field weakening mode, this results in an inadmissible armature voltage overshoot.

Switch-on via terminal 37 and issue operating enable via terminal 38.

15.3

Increase setpoint until "100" is displayed in P01.

15.4

Set the rated speed (100%) using potentiometer R1 (rough) and R2 (fine). The motor speed can be measured using a handheld tachometer (accuracy).

15.5

Set setpoint to "0"

Switch-on via terminal 37 and enter operating enable via terminal 38.

16

Setting supplementary functions

17

Activate write protection for non-volatile memory

- Set parameter P87 (protection against subsequent parameter changes)
- Set plug-in jumper XJ1 on board A1660, into position 2-3 (hardware write protection)

NOTE

The hardware write protection can only be inserted when the software write protection is simultaneously activated, refer to parameter P87.

It is only permissible to change the plug-in jumper with the electronics power supply switched-out.

18

Documentation of the settings

- Note parameters
- Print-out parameters with P51 = 30 (refer to Section 9 "Parameter list")
- Transfer the parameters in the PG or PC with P51 = 31 (refer to Section 9 "Parameter list") (the PGIN software is required on the PG, the PCIN software is required on the PC).

7.6 Field supply

7.6.1 Information for operation with an uncontrolled field supply

The motor field winding resistance is a function of the temperature (for copper, a temperature coefficient of $\alpha = 3.95 \cdot 10^{-3} \text{ K}^{-1}$).

Thus, for a constant supply voltage at field winding the field current is also dependent on the motor operating temperature.

When designing the drive, this must be taken into account when defining the maximum speed. Otherwise, if the motor is cold, it may not reach the required speed as a result of the higher field current due to the lower field winding resistance (also refer to the motor rating plate).

7.6.2 Start-up with an external field converter (field weakening)

If the field is supplied from an external field converter (e.g. to permit field weakening), the following settings must be made in addition to the start-up procedure up until now:

7.6.2.1 Setting the field controller in the external field converter

It is necessary to optimize the controller parameters on the external field converter to ensure good control dynamics, even in field weakening. MINIREG F10 and MINIREG F33 field converters are generally sufficiently optimized for most applications (refer to recommended circuit configuration, Section 10.16).

K_p and T_n should be optimized for field converters with adjustable PI controllers.

If the experience values for K_p and T_n do not provide successful operation, the controller parameters should be set according to the symmetrical optimum based on the following:

$$K_p = \frac{R_F [\Omega] \times I_N [\text{A}] \times \tau_F [\text{ms}]}{U_F [\text{V}] \times 30} \quad T_n = 100 \text{ ms}$$

Def.: $K_p = P$ gain $K_p = 1$ means that a setpoint-actual value difference at the controller input, with the same magnitude as the rated field converter current results in a proportional component at the current controller output, which results in a 90 degree firing angle.

T_n = integral-action time, R_F = field winding resistance, I_N = rated field converter current, τ_F = Minimum field time constant (at maximum field)

Execution:

- 1) Check start-up step 9.2 (level adaption, field current setpoint between the converter and external field converter)
- 2) Check the controller setting by entering setpoint steps (fastest possible field current rate of rise with acceptable overshoot).

**WARNING**

If the overshoot is excessive, this can result in the armature voltage exceeding the permissible value. The armature current can also overshoot when setpoint steps are made in field weakening mode.

NOTE

Setpoint steps can be initiated via the ON terminal (terminal 37), and at the select outputs which can be parameterized (terminal 14 or 16) (P88 = 2).

7.6.2.2 Automatic field characteristic plot**NOTE**

When starting-up several identical motors, it is recommended that the automatic field characteristic plot is made for each individual drive, as even though the motors are the same type, the magnetization characteristics can be different from motor to motor.

The field current setpoint is generated from a combination of the speed-dependent field current pre-control and closed-loop EMF control. Thus, the relationship between speed and field current setpoint must be plotted for a specific EMF setpoint (field characteristic). The field characteristic plot, a start-up routine, which internally issues the speed-, armature current- and field current setpoints, is initiated automatically after start. The user has direct access via the parameterization to information on the plotted characteristic (L parameters).

NOTE

The automatic field characteristic plot assumes that the speed has been finely adjusted according to start-up step 15.

Execution:

- 1) Check P77 (EMF in volt, where field weakening should start) (refer to start-up step 15.1)
- 2) Further, the following should be set:

P88	Operating mode selection for automatic field current reduction
P90 = 2	Field weakening control mode
P96	Standstill field current

**WARNING**

The drive rotates with the speed corresponding to the start of field weakening!
(i.e. the motor rated speed)

- 3) Start the field characteristic plot with $P51 = 5$ as for the optimization run.
The L parameters are set

P90 is automatically set to 0, after the field characteristic has been successfully plotted, i.e., the closed-loop EMF controller and field current pre-control are enabled for closed-loop field control.

Note

When the field current pre-control is activated ($P90 = 0$), the factory settings can be retained for the closed-loop EMF controller.

7.7 Manual optimization and manual field characteristic plot

7.7.1 Manual armature current controller optimization

NOTE

Parameter changes are only transferred into the non-volatile memory (EEPROM), if there is no protection against subsequent parameter changes (no hardware and software write protection) refer to Section 7.5, Start-up step 17.

7.7.1.1 Pre-control setting

Execution:

- 1) Disconnect the motor field (terminals 3U1, 3W1).
- 2) Connect a 10V instrument between the analog select output terminal 16 and ground, terminal 15.
- 3) Assign a select output and normalize:
 - P51 = 20 (key parameter)
 - P37 = 8, P38 = 1 (for software release 1.0), E12 = 1 (from software release 4.0) (EMF output at the analog select output, terminal 16)
- 4) P89 = 3 (the speed controller is inhibited, the main setpoint is interpreted as current setpoint)

NOTE

In the closed-loop current controlled mode, for a positive output current at terminal 1C (torque direction I), a positive setpoint (terminal 4 positive, with respect to terminal 5) is required.

- 5) P63 = 4 (pre-control is inhibited, the current controller is enabled)
 - L34 = 0 (offset to the supply zero crossover)



WARNING



The drive is current controlled, and can reach an overspeed condition after it has accelerated due to the residual motor field (if required, lock the rotor).

- 6) Switch-on via terminal 37 and issue an operating enable via terminal 38.
- 7) Determine the armature circuit resistance (R component):
 - Enter a current setpoint of 30%
 - Adjust P67 until the EMF value at the voltmeter is "0".
 - Set P66 the same as P67
 - Enter current setpoint "0".

- 8) Determine the discontinuous/continuous current limit:

The continuous/discontinuous current limit (P68) is either determined by making an oscilloscope trace of the armature current between terminals 12 and 13 and then reading the value of P04 (current actual value display = continuous/discontinuous current limit as a % of the rated converter current), or by calculating.

$$P68 = \frac{V_{RMS}}{I_{rated}} \times \frac{1}{L_{armature}} \times 40$$

V_{RMS} RMS value of the supply voltage

I_{rated} Rated converter current

$L_{armature}$ Armature inductance in mH

- 9) Offset adjustment for determining the zero crossover point of the supply:

P63 = 0 (switch-in pre-control)

P37 = 7 (current controller integrator output)

- 9.1) If the continuous/discontinuous current limit \leq P71:

Enter a current actual value of 30%, and change L34, until the minimum output voltage has been reached at the select output, terminal 16.

- 9.2) If the continuous/discontinuous current limit $>$ P71:

Enter a current setpoint of 30% and increase P68, until the minimum output voltage is reached at select output, terminal 16.

- 10) Enter current setpoint "0" and switch-off.

- 11) Switch-in the motor field current (3U1, 3W1).

- 12) P89 = 0 (closed-loop speed control)

- 13) P51 = 0

7.7.1.2 Current controller setting

P64 P gain

P65 Integral action time T_N

P63 Operating mode for feed-forward control and current controller

NOTE

When the pre-control has been correctly set, the controller parameters (factory setting) are sufficiently optimized for the current controller.

7.7.2 Manual speed controller optimization

NOTE

Parameter changes are only transferred into the non-volatile memory (EEPROM), if there is no protection against subsequent parameter changes (no hardware or software write protection), refer to Section 7.5, Start-up step 17.

Execution:

- 1) P51 = 20 (key parameter)
- 2) Set the experience values for P31 (speed controller proportional coefficient) and P32 (speed controller integral action time in s).
Experience values: P32 = 4 x P65
P31 = 5 to 20 ms
- 3) Increase P31 until the speed starts to oscillate, and then reduce the value of P31 to 50 %.
- 4) P51 = 0

7.7.3 Manual optimization of the closed-loop EMF controller

NOTE

Parameter changes are only transferred into the non-volatile memory (EEPROM), if there is no protection against subsequent parameter changes (no hardware or software write protection), refer to Section 7.5, Start-up step 17.

Execution:

- 1) P51 = 20 (key parameter)
- 2) P90 = 2 (closed-loop EMF control without pre-control)
- 3) Initiate speed changes in the field weakening range by entering setpoint steps.
- 4) Set the closed-loop EMF controller integral action time P79 and P gain P78, so that the armature voltage only changes slightly.
Experience values: P79 = 0.5s
P78 = 3
- 5) P90 = 0 (closed-loop EMF control and pre-control)
- 6) P51 = 0

7.7.4 Manual field characteristic plot

NOTE

The manual field characteristic plot should only be done in exceptional cases - if it is not possible to make an automatic field characteristic plot. The L parameters can only be written into (storing the characteristic points), offline, i.e., the parameter values to be determined in the following procedure should first be documented and then stored as parameter value.

The tachometer must first be finely adjusted.

The field current setpoint for the external field converter must be supplied from a separate voltage source (0 to 10 V).

An ammeter should be connected in the field circuit to measure the field current actual value.

Execution:

NOTE

Parameter changes are only transferred into the non-volatile memory (EEPROM), if there is no protection against subsequent parameter changes (no hardware or software write protection), refer to Section 7.5, Start-up step 17.

- 1) Disconnect the motor from the load (if possible)
Disconnect the field current setpoint output (terminal 14 or 16), and connect an external voltage source to the setpoint input of the external field converter.
- 2) The drive must be in operating status o7 or higher.
- 3) Set the following parameters:

P51 = 20	Key parameter
P77	EMF setpoint at the speed at which field weakening starts (refer to Section 7.6.2)
- 4) Set 100% rated field current (external voltage source).
- 5) Select parameter P01 (display n_{set}), changeover into the value mode, and enter "0" using the speed setpoint.



WARNING



In the following procedure, the speed setpoint must only be slowly increased in order to prevent an inadmissible armature voltage overshoot.

- 6) Switch-on via terminal 37, and issue operating enable via terminal 38.
- 7) Select parameter P07 (EMF display), changeover into the value mode, and increase the speed setpoint, until an EMF equal to EMF_{set} is obtained. The associated speed is then the speed at which field weakening is started, and should be left constant in the following procedure.

Parameter L10 (speed at the start of the field weakening) = contents of P02 (speed actual value).

- 8) Determine the characteristic points:
With the speed kept constant (speed at which field weakening starts), the associated EMF values (P07) are plotted while the field current is reduced in steps, and the field characteristic parameters are then subsequently calculated (L11 to max. L30):

$$L_{xx} = \frac{EMF_{set}}{EMK} \times P02 \quad L_{xx} \dots L_{11} \text{ up to max. } L_{30}$$

NOTE

The field current should be reduced, until an L parameter < 100% is obtained. All additional parameters must then no longer be determined.

I_{field} % from $I_{field \text{ rated}}$	100	84.7	71.8	60.8	51.4	43.5	36.9	31.0	26.3	22.4	18.8	16.1
I_{field} [A]												
EMF (P07)												
Lxx % of n_{max}	L10	L11	L12	L13	L14	L15	L16	L17	L18	L19	L20	L21
Parameter value for L31	0	2	4	6	8	10	12	14	16	18	20	22

I_{field} % of $I_{field \text{ rated}}$	13.3	11.4	9.8	8.2	7.1	5.9	5.1	4.3	3.5
I_{field} [A]									
EMF (P07)									
Lxx % of n_{max}	L22	L23	L24	L25	L26	L27	L28	L29	L30
Parameter value for L31	24	26	28	30	32	34	36	38	40

- 9) Set the speed setpoint to "0", enter the stop signal and inhibit operating enable.
- 10) Determine L32 as follows:
 Re-connect the field current setpoint to the SIMOREG converter (terminal 14 or 16).
 Switch-on via terminal 37 and enable the controller via terminal 38.
 Increase the speed setpoint until n_{max} of 100% is reached, and read-off $I_{field\ min}$.

$$I_{field\ min} = \dots \quad L32 = \frac{I_{field\ min}}{I_{field\ rated}} \times 255 \quad L32 = \dots$$

- 11) Set the speed setpoint to "0", enter the stop signal and inhibit operating enable.
- 12) Read-off L31 from the table above (value of that L31 parameter, for which $L_{xx} > 100\%$)
 L31 =
- 13) Set the determined parameter (L10 to max. L30, L31 and L32) as L parameter.
- 14) Further, the following should be set:
- L08 = 1 "Field characteristic plotted" flag
- L09 as P77
- P90 = 0 Field pre-control and closed-loop EMF control operational

8 Operation

8.1 Operating statuses, parameter P00

Torque direction M0, MI or MII (= RUN)

- No torque direction switched-in (M0)
- I Torque direction I switched-in (MI)
A positive output current flows from 1C1 (1D1) to 1D1 (1C1)
- II Torque direction II switched-in (MII) (only for 4-quadrant converters)
A negative output current flows from 1C1 (1D1) to 1D1 (1C1)

If the motor does not run, even when a setpoint is entered, and -- is displayed for parameter P00, then parameter P01 (setpoint) P83, P84 and P85 (select terminals) and P39 to P42 (current limits) should be checked. If a select terminal is parameterized for the ramp-function generator enable function, it must be energized.

The hundred's digit of parameter P00 (operating status display) indicates whether the speed setpoint is at a limit, and whether the current setpoint is also at a limit.

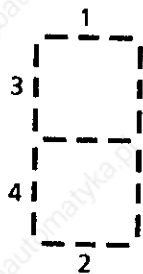

Segment 1 lit,

if the speed controller setpoint is at the positive limit (torque direction MI)

Segment 2 lit,

if the speed controller setpoint is at the negative limit (torque direction MII)

Segment 3 lit,

if the current controller setpoint is at the positive limit (torque direction MI)

Segment 4 lit,

if the current controller setpoint is at a negative limit (torque direction MII)

o1 Wait for operating enable (= READY)

No enable signal at terminal 38 (open or < 4.5 V)

By applying an enable signal (17-30 V at terminal 38), the wait status is left, and a jump is made to RUN.

o2 Test phase

The line supply and thyristors are checked (refer to parameter E39).

If the supply and the thyristors are O.K., a jump is automatically made to operating status o1.

o3 Wait for voltage (armature)

Wait for voltage at the power connections 1U1, 1V1, 1W1.

If voltage is measured at the power terminals within 2s (line contactor is switched-in), a jump is made into operating status o2.

Otherwise, fault message F04 is displayed.

o4 External fault present

This is only displayed, if terminal 39 or 40 has been selected as "external fault" (P83 or P84 = 15).

External fault present (terminal 39 or 40 open-circuit, or <4.5 V).

If the external fault is removed within 2s (17 V to 30V applied to terminal 39 or 40), the drive goes into operating status o3.

Otherwise, fault message F14 is displayed.

o5 Not used**o6 OFF (other designations: OFF2, voltage disconnected)**

This is displayed if terminal 39 or 40 is selected as "OFF" (P83 or P84 = 6). OFF signal is entered (terminal 39 or 40 open-circuit or >4.5 V). The wait condition is exited, and a jump made to another operating display when "OFF" is cancelled (by applying 17 V to 30 V at terminal 30 or 40).

This can also occur, if "OFF" is internally issued by the drive, e.g. when acknowledging a fault message with the motor still running (refer to Section). The drive can be restarted after terminal 37 has been opened by re-energizing terminal 37 (e.g. entering "ON").

o7 Wait for switch-on (= READY-TO-SWITCH-ON)

A stop signal has been entered (terminal 37 open or <4.5 V). The wait condition is exited and a jump made to the next operating display by applying an ON signal (17 V to 30 V at terminal 37).

o8 FAST STOP (OFF3)

This is only displayed, if terminal 39 or 40 is selected as fast stop (P83 or P84 = 7).

Fast stop is entered (terminal 39 or 40 open-circuit or <4.5 V).

The wait status is exited, and a jump made to the next operating display by cancelling fast stop (by applying 17 to 30 V to terminal 39 or 40) and then opening and closing terminal 37 (ON/STOP). The FAST STOP function is also effective in the closed-loop current control mode (P89 = 3)! If FAST STOP is entered in the closed-loop current control mode, the speed controller is automatically switched-in, and the FAST STOP function is executed using the speed controller.

CAUTION: In this case, the speed controller parameters must be roughly set to the correct positions!

CAUTION: The FAST STOP function is ineffective in the setting P63 = 3!

8.2 Fault messages

When a fault occurs in operating statuses I, II or --

- the binary output function "fault" is set to low
- the drive is shutdown ("power ON" relay drops-out)
- Fxx is displayed on the operator control panel (xx = fault number) flashing (approx. 0.8 s lit, approx. 0.2 s dark)

To disable monitoring functions, refer to Section 10.13.

8.2.1 Acknowledging fault messages

Restart with acknowledgement

If a fault is displayed, it must be acknowledged by depressing the mode button on the drive or by applying a low-high transition at terminal 39 or 40 (refer to P83, P84 and "list of the binary input functions" Section 10).

For a digital coupling, fault acknowledgment is also possible via the control word.

Restart without acknowledgement

If parameter P87 is set to x2 or x3, the drive can be restarted by energizing the on/stop terminal (open-circuit or <math><4.5\text{ V}</math>) with the following faults present (it is not necessary to acknowledge at the drive itself):

- F04: Phase failure, line fuse blown
- F05: Line supply voltage outside the tolerance (+ 15% / -20%)
- F12: Current actual value > 300% of the rated drive current
- F13: I²t monitoring function has responded
- F14: External fault

The fault display is maintained, however, it no longer flashes. It can be acknowledged at the drive.

Automatic restart at phase failure

If x1 or x3 is set at parameter P87, automatic restart is realized after phase failure if the phase returns within 1s.

8.2.2 List of the fault messages

F02 Incorrect phase sequence (electronics power supply 5U1, 5V1, 5W1)

F03 Supply frequency not in the 45 Hz to 65 Hz range or, frequency change > 12Hz/s

also refer to Section 10. (operation on weak supplies)

F04 Phase failure, line fuse

This also occurs when the supply voltage is disconnected with terminal 37 (on) energized.

F05 Supply voltage out of tolerance (+ 15 / -20%)

F06 F06 parity error, data received via the serial interface

F07 Syntax error, data receive via the serial interface

F08 Framing error, data receive via the serial interface

F09 Overrun error, data receive via the serial interface

F10 Overspeed signal

This responds, if the speed, set at parameter E21, is exceeded. The fault signal is switched-out for E21 = 0.

F11 Tachometer fault (analog tachometer) or interrupted armature circuit

Cable interrupted, tachometer overloaded or incorrect tachometer polarity. Speed actual value ripple too high.

(for software release 1.0, F11 is the fault message for the analog tachometer and pulse encoder, from software release 4.0, for faulted pulse encoder F24).

F12 I > 300%

Current actual value > 300% of the rated converter current.

F13 I²t monitoring responded (motor too hot)

This fault message is suppressed for P70 = 0.
Counter-measure: Reduce the motor load.

F14 External fault

External fault monitoring is activated by selecting a binary select input (terminal 39 or 40) (P83, P84). The fault message occurs, if a low signal is present at terminal 39 or 40 for longer than 1 s. The delay time is 2 s in operating status o4.

F15 Speed controller monitoring

Setpoint-actual value difference $> P27$ for a time $\geq P43$.

Possible causes: – poor speed controller optimization
– tachometer cable interrupted, incorrect tachometer polarity

F16 Drive stalled

$I_A \geq I_{limit}$ with the drive stationary, shutdown time can be set using parameter P43. The fault message is suppressed for $P43 = 0$.

F18 Drive does not reach rated speed in spite of maximum field weakening

Only for an external field supply unit.

The fault can only occur during field characteristic plotting.

Possible causes: – Response voltage P77 set to $< 120V$
– Field current actual value does not follow the field current setpoint

Counter-measure: Re-plot the field characteristic after checking P77.

F19 Armature current cannot flow

e.g. fuse ruptured, cable interrupted etc.

Possible causes: – Field current too high (P76)
– Response voltage too high (P77)

F20 Electronics power supply failure (5U1, 5V1, 5W1)

The fault signal for the electronics power supply is present for longer than 1.28 s or the monitoring periodically responds.

F22 Fault in the phase assignment between the electronics power supply (5U1, 5V1, 5W1) and the voltage at the power section (1U1, 1V1, 1W1)

Counter-measure: Make sure that the power section and the electronics supply have the same phase sequence.

F23 Coupling, dual port RAM interface faulted

Faulty technology- or interface board.

For more detailed information refer to the Operating Instructions for the option boards.

F24 Fault in the measuring channel for the digital speed sensing via pulse encoder or interrupted armature circuit

Fault on the encoder cables or defective pulse encoder.

- Possible causes:
- EMC disturbances on a pulse encoder signal (terminals 28 to 30)
 - Defective pulse encoder
 - Short-circuited encoder cable with respect to the supply voltage or another encoder cable
 - Channels interchanged
 - Negative inputs of the pulsed encoder evaluation are not connected to ground
 - Defective A1660 electronics board

F25 Fault in the measuring channel for the armature voltage or a fault in a measuring channel for analog input signals

Main setpoint (terminals 4 and 5), analog select input (terminals 6 and 7), speed actual value (terminals 101 to 104).

- Possible causes:
- Defective A1660 electronics board
 - "Main setpoint" or "select signal" input voltage greater than approx. 11.3 V (measuring circuit over-driven)

F26 Armature current cannot be reduced at torque direction reversal

EMF is too high

Counter-measure without field weakening: Reduce field current
For operation with external controlled field converter, reduce P76

Forr field weakening: Reduce P77 and plot field characteristic)

F27 USS telegram failure at G-SST1 from SW1.1

Active from when the first valid protocol is received in all operating statuses.

Mode of operation

If a valid protocol was received, and no further telegram is received after a time, longer than that set at parameter P75.

Possible error causes

- Interrupted cable connection
- USS master, fault/error

F28 FIFO overflow

Possible cause: Fault on the electronics board (A1660)
(synchronization, current = 0 signal)

F29 Parameter value outside the permissible range

The parameter values from the EEPROM memory are loaded into the operating memory (RAM) immediately after the electronics power supply has been switched-on. It is checked, as to whether the values lie within their legal range - if this is not the case, F29 is output.

Possible causes:

- "Establish factory setting" was not executed using this software (e.g. after software replacement)
- Excessive EMC disturbances present (e.g. as a result of undamped contactors, unscreened cables, loose screen connections)
- For the "establish factory setting" function, write protection is active (jumper XJ1 in setting 2-3).

Counter-measure: Acknowledge fault, "establish factory setting" and start-up the drive again!

F30 Fault during field characteristic plotting

This fault can only occur during field characteristic plotting.

Possible causes:

- Load surge during the characteristic plot
- Electronics board fault

Counter-measure: Re-plot the field characteristic

F31 Transition from discontinuous to continuous armature current lies above the rated motor current, set using P71

During the optimization run it was determined, that the transition from discontinuous to continuous armature current was above the rated motor current, set using P71. Parameter L34 was therefore not able to be adjusted.

Counter-measure:

P68 (the transition from the discontinuous to continuous armature current limit)

$P68 < 100$

The transition from discontinuous to continuous armature current lies below the rated converter current.

The fault message information only relates to parameter L34 which has not been set. Non-hazardous drive operation is possible with the selected values.

$P68 = 100$

The transition from discontinuous to continuous armature current lies above the rated converter current.

The feed-forward control cannot be correctly set.

Counter-measure:

Increase the inductance in the DC circuit using a smoothing reactor in the armature circuit and re-optimize.

F32 Optimization run: Remanence too high

Drive rotates at $I_{\text{field, set}} = 0$

Counter-measure: Lock the motor rotor

F34 EEPROM fault

Cyclic comparison between the RAM/EEPROM identified different memory contents.

Possible causes:

- Hardware write protection inserted, although no software write protection is parameterized (refer to parameter P87)
- Defective EEPROM on the A1660 electronics board

F35 Fault in field weakening operation

This is initiated, if EMF_{set} (P77) is not 0 and a characteristic has not been plotted.

Counter-measure: Plot the field characteristic

F36 Optimization run: Current limit too low

The current limit is reached during automatic optimization.

Counter-measure: The current limits (P39 and P41) should only be temporarily increased for the optimization run.

Note: For high moments of inertia, execute manual optimization, refer to Section 5.7.

F37 Optimization run was terminated due to external causes

e.g. STOP

Counter-measure: Repeat optimization run

F38 Hardware does not match-up with the option set using E00, or the options, set using parameter E00 mutually exclude each other

Counter-measure: Set parameter E00

F39 Optimization run with active permanent memory inhibit not possible.

Counter-measure: Set P87 to 3 x

NOTE

This group of fault messages can only occur, if the thyristor check is activated via parameter E39. If "defective thyristor" is signaled, the appropriate thyristor module should be replaced. Although thyristors can fail, repetitive fault messages indicate a possible fault in another area.

Possible causes:

- Snubber circuitry interrupted
- Current controller and pre-control not optimized
- Cooling faulted (e.g. fan not running, ambient temperature too high, air intake too low, heatsink dirty)
- Excessive voltage spikes on the supply
- External short-circuit or ground fault (check armature circuit)

If the signal "thyristor cannot be triggered" is issued, this is generally caused by a fault in the firing circuit and not due to a faulty thyristor.

Possible causes:

- Firing pulse cable to the corresponding thyristor interrupted
- Ribbon cable X100 not correctly inserted or interrupted
- Defective electronics and gating board
- Internal open circuit in the gate conductor in the thyristor module

Thyristor module arrangement

Converters 15A, 4Q

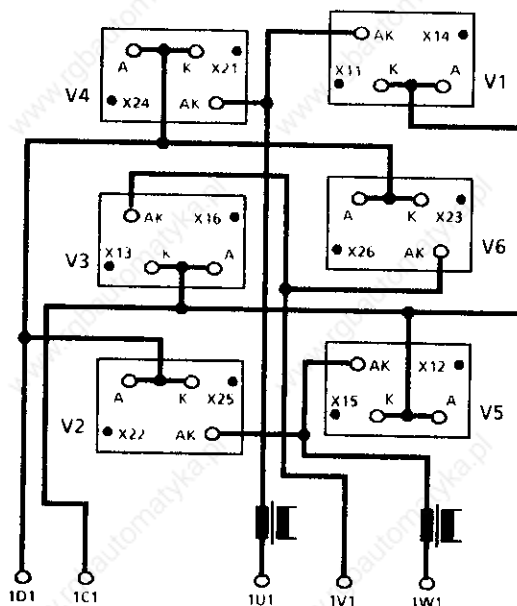

Converters, 30A to 250A, 1Q

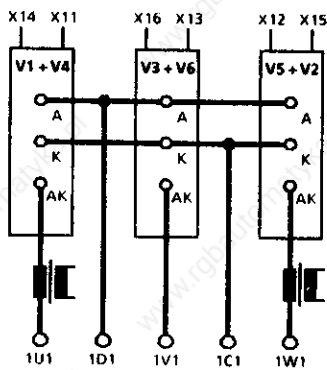

Converters, 30A to 250A, 4Q

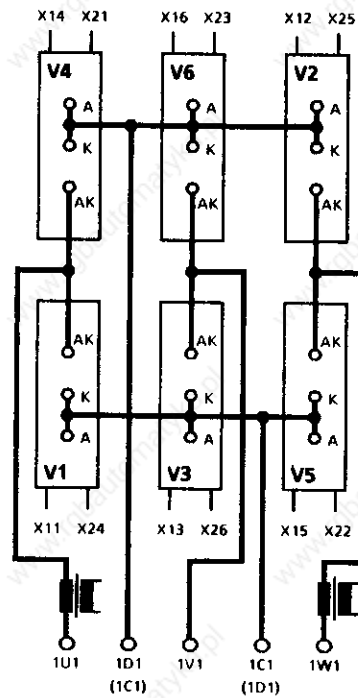

Converters, 400A to 600A, 1Q

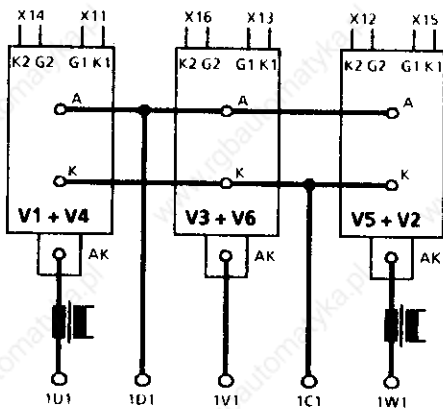

Converters, 400A to 600A, 4Q

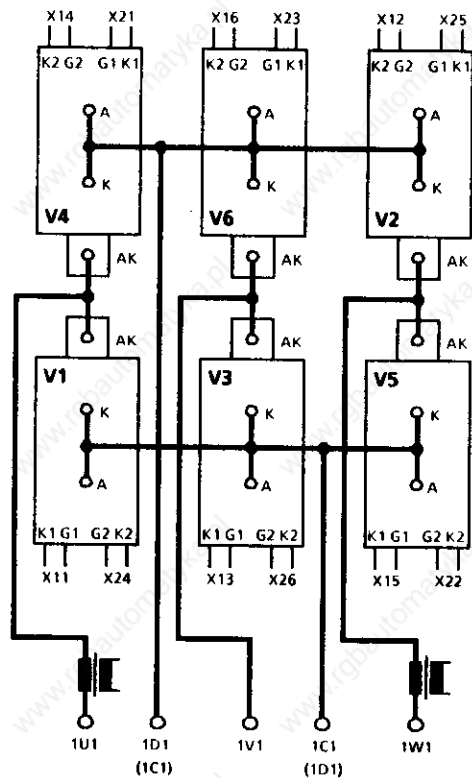

F41 Defective thyristor

Short-circuit in thyristor module V1

F42 Defective thyristor

Short-circuit in thyristor module V2

F43 Defective thyristor

Short-circuit in thyristor module V3

F44 Defective thyristor

Short-circuit in thyristor module V4

F45 Defective thyristor

Short-circuit in thyristor module V5

F46 Defective thyristor

Short-circuit in thyristor module V6

F47 2 or more thyristors cannot be triggered (M I)

Possible causes:

- Armature circuit interrupted (check DC fuses, motor feeders and brushes)
- Ribbon cable X101 interrupted
- Defective electronics board

F48 2 or more thyristors cannot be triggered (M II)

Possible causes for 1Q converters:

- Parameters P81 or P99 incorrectly set

Possible causes for 4Q converters:

- Armature circuit interrupted (check DC fuses, motor feeders and brushes)
- Ribbon cable X101 interrupted
- Defective electronics board

F49 I = 0 - signal defective

Possible causes: Defective electronics board or external noise

Remedy: Connect RC elements to contactors

F50 External interrupt

Set line EXT_INT to log.0 (X100.54) via interface X100.

Counter-measure: Refer to the Instruction Manual of the connected supplementary board.

F51 Thyristors cannot be triggered (gate G11)

Possible causes: Interrupted gating conductor or defective electronics- or gating board, gate internally interrupted in the thyristor.

F52 Thyristor cannot be triggered (gate G12)

Possible causes: Interrupted gating conductor or defective electronics- or gating board, gate internally interrupted in the thyristor.

F53 Thyristor cannot be triggered (gate G13)

Possible causes: Interrupted gating conductor or defective electronics- or gating board, gate internally interrupted in the thyristor.

F54 Thyristor cannot be triggered (gate G14)

Possible causes: Interrupted gating conductor or defective electronics- or gating board, gate internally interrupted in the thyristor.

F55 Thyristor cannot be triggered (gate G15)

Possible causes: Interrupted gating conductor or defective electronics- or gating board, gate internally interrupted in the thyristor.

F56 Thyristor cannot be triggered (gate G16)

Possible causes: Interrupted gating conductor or defective electronics- or gating board, gate internally interrupted in the thyristor.

F61 Thyristor cannot be triggered (gate G21) (fault message only possible for 4Q converters)

Possible causes: Interrupted gating conductor or defective electronics- or gating board, gate internally interrupted in the thyristor.

F62 Thyristor cannot be triggered (gate G22) (fault message only possible for 4Q converters)

Possible causes: Interrupted gating conductor or defective electronics- or gating board, gate internally interrupted in the thyristor.

F63 Thyristor cannot be triggered (gate G23) (fault message only possible for 4Q converters)

Possible causes: Interrupted gating conductor or defective electronics- or gating board, gate internally interrupted in the thyristor.

F64 Thyristor cannot be triggered (Gate G24) (fault message only possible for 4Q converters)

Possible causes: Interrupted gating conductor or defective electronics- or gating board, gate internally interrupted in the thyristor.

F65 Thyristor cannot be triggered (gate G25) (fault message only possible for 4Q converters)

Possible causes: Interrupted gating conductor or defective electronics- or gating board, gate internally interrupted in the thyristor.

F66 Thyristor cannot be triggered (gate G26) (fault message only possible for 4Q converters)

Possible causes: Interrupted gating conductor or defective electronics- or gating board, gate internally interrupted in the thyristor.

F71 1Q converters: Thyristor cannot block (gate G11)

Remedy: Replace thyristor module V1 + V4

4Q converters: Thyristor cannot block (gate G11 or G21)

Remedy: Replace thyristor module V1 and V4

F72 1Q converters: Thyristor cannot block (gate G12)

Remedy: Replace thyristor module V2 + V5

4Q converters: Thyristor cannot block (gate G12 or G22)

Remedy: Replace thyristor module V2 and V5

F73 1Q converters: Thyristor cannot block (gate G13)

Remedy: Replace thyristor module V3 + V6

4Q converters: Thyristor cannot block (gate G13 or G23)

Remedy: Replace thyristor module V3 and V6

F74 1Q converters: Thyristor cannot block (gate G14)

Remedy: Replace thyristor module V1 + V4

4Q converters: Thyristor cannot block (gate G14 or G24)

Remedy: Replace thyristor module V1 and V4

F75 1Q converters: Thyristor cannot block (gate G15)

Remedy: Replace thyristor module V2 + V5

4Q converters: Thyristor cannot block (gate G15 or G25)

Remedy: Replace thyristor module V2 and V5

F76 1Q converters: Thyristor cannot block (gate G16)

Remedy: Replace thyristor module V3 + V6

4Q converters: Thyristor cannot block (gate G16 or G26)

Remedy: Replace thyristor module V3 and V6

9. Parameter list

The parameter list handles all of the basic converter parameters. The parameter overview (Section 9.1) is arranged according to functions, and the parameter description (Section 9.2) is arranged according to parameter numbers (P., E. and L.).

Additional parameters, which are required in conjunction with option boards, are documented in the associated Operating Instructions.

9.1 Parameter overview (arranged according to functions)

Parameter number	Function
Display parameters	
P00	Display of operating statuses
P01	Display, speed setpoint (terminals 4 and 5)
P02	Display, speed actual value
P03	Display, armature current setpoint/absolute value
P04	Display, armature current actual value/absolute value
P05	Display, gating unit firing angle
P06	Display, current controller integrator
P07	Display, EMF/absolute value
P08	Display, armature voltage/absolute value
P09	Display, analog input (terminals 6 and 7)
P10	Display, RMS value of the supply voltage
P15	Digital input and output statuses
L06	Display, ramp-function generator output for the motorized potentiometer
L07	Display, EMF / n_{act} normalized
Access authorizations and parameter output	
P51	Key parameter
P52	Establish factory setting
P87	Select operating mode for restart and software write protection
Definition of the SIMOREG converter	
P93	Rated supply voltage/output (according to the rating plate)
P99	Setting the converter version and software release
E00	Hardware configuration

Parameter number	Function
Converter control settings	
P50	Changeover speed
P53	Selecting the speed actual value
P81	Auto-reversing stage mode
P87	Selecting the mode for restart and fault acknowledgement
P88	Selecting the mode for automatic field current reduction
P98	Voltage adaption for the electronics power supply
L33	Supply frequency tracking/response threshold F11
Motor definition	
P70	Thermal time constant for I ² t motor monitoring
P71	Ratio of the rated motor current/rated converter current
P76	Field current setpoint
P96	Standstill field current
Pulse encoder definition	
P54	Pulse encoder type
P55	Pulse encoder, pulse number (thousands)
P56	Pulse encoder, pulse number (one's-, ten's-, hundred's position)
P57	Control word for the pulse encoder
P58	Maximum speed with the pulse encoder
P59	Maximum speed with the pulse encoder
Armature current control settings	
P62	Ramp-up time for reduced gearbox stressing
P63	Mode for pre-control and current controller
P64	Current controller P gain
P65	Current controller, integral action time T _n
P66	Pre-control, R component in the discontinuous current range
P67	Pre-control, R component in the continuous current range
P68	Discontinuous/continuous limit of the armature current
P94	Gating unit, rectifier stability limit, alpha G
P95	Gating unit, inverter stability limit, alpha W

Parameter number	Function
Current and torque limiting settings	
P39	Positive current limit
P40	Negative current limit
P41	Positive current limit 2 for torque direction I
P42	Negative current limit 2 for torque direction II
P44	Absolute current limit for gearbox stage II
P48	Start of the speed-dependent current limit
P49	Current limit at maximum speed (n_{max})
E68	Torque limit
E70	Selecting the mode for closed-loop torque control
Speed actual value conditioning settings	
P20	Actual value filtering
E03	Selecting the filter type and activating the speed controller monitoring
E04	Suppression quality of the bandstop filter
E05	Resonant frequency of the bandstop filter
E06	Resonant frequency of the bandstop filter for gearbox ratio, stage II
E33	IxR compensation of measured V_d
E34	Maximum speed for operation without tachometer (EMF = speed actual value)
Speed controller settings	
P28	Initial value of the speed controller integrator after controller enable
P30	Offset adjustment of the speed controller
P31	Speed controller, P gain
P32	Speed controller, integral action time
P33	Speed controller, P gain, gearbox stage II
P34	Speed controller integral action time, P gearbox stage II
P60	Adaption factor for the closed-speed controller, P component
P61	Adaption factor for the closed-loop speed controller, integral action time
P89	Speed controller operating mode

Parameter number	Function
Closed-loop EMF control settings	
P77	EMF setpoint at the transition speed to field weakening
P78	EMF controller, P gain (in field weakening)
P79	EMF controller, integral action time T_m (in field weakening)
P90	Field weakening control mode
Ramp-function generator settings	
P16	Ramp-function generator, ramp-up time 1
P17	Ramp-function generator, ramp-down time 1
P18	Ramp-function generator, initial rounding-off 1
P19	Ramp-function generator, final rounding-off 1
E16	Ramp-function generator, ramp-up time 2
E17	Ramp-function generator, ramp-down time 2
E18	Ramp-function generator, initial rounding-off 2
E19	Ramp-function generator, final rounding-off 2
Monitoring and limit settings	
P21	Settings for $n < n_{min}$ signal
P23	Speed threshold, gearbox stage I
P24	Speed threshold, gearbox stage II
P27	Response threshold for the speed controller monitoring function
P43	Shutdown time for anti-stall protection
P47	Current threshold (I_x)
E21	Response threshold for overspeed signal F10
E86	Hysteresis for signals $n < n_x$, $I_A > I_x$
E87	Hysteresis for "direction of rotation" signal
Settings for the basic converter - technology functions	
P11	Speed setpoint, inching 1
P12	Speed setpoint, inching 2
P13	Crawl setpoint
P14	Inching mode
P72	Gearbox ratio, stage I
P73	Gearbox ratio, stage II

Parameter number	Function
E20	Selecting the mode for the motorized potentiometer function
E41	Changeover threshold, P/PI speed controller
E60	Droop
E61	Setpoint reduction
Analog inputs	
P85	Assigning select terminals 6 and 7 (analog select input)
E01	System voltage, speed setpoint (terminals 4 and 5)
E02	System voltage for the analog supplementary input (terminals 6 and 7)
Analog outputs	
P35	Assignment of select terminal 14 (analog select output 1)
E11	Norm. factor for select term. 14 (anal. select output 1) from SW4.0 for SW1.0: P36
P37	Assignment of select terminal 16 (analog select output 2)
E12	Norm. factor for select term. 16 (anal. select output 2) from SW4.0 for SW1.0: P36
P86	Mode for analog output terminal 12 I_{act}
Binary inputs	
P83	Selecting the function of terminal 39 (binary select input 1)
P84	Selecting the function of terminal 40 (binary select input 2)
Binary output	
P80	Mode, binary select output terminal 46, open emitter
Serial interface	
P97	Control parameter for the serial interface
P74	Bus address for G-SST1 (RS232) at X501 (or RS485 with interface converter 6RX1240-0AL01)
P75	Telegram failure time for G-SST1 (RS232) at X501 (or RS485 with interface converter 6RX1240-0AL01)
Disabling fault messages	
P91	Suppressing fault message
P92	Suppressing fault message

Parameter number	Function
Diagnostic function settings	
E39	Thyristor check
A - L	Diagnostic address, low byte
A - H	Diagnostic address, high byte
≡ - ≡	Contents of the diagnostic memory location
SHI	Number of shifts for the analog diagnostic function
L05	Last fault
Converter-internal settings	
L04	Various flag bits
L08	"Field characteristic plotted" flag
L09	EMF setpoint at the response speed
L10	Speed at the start of field weakening
L11	1st characteristic point for the field characteristic
L12	2nd characteristic point
to	to
L30	20th characteristic point
L31	2x number of valid characteristic points
L32	Minimum field current at n_{max} [255 = rated field current (P76)]
L34	Offset to the supply zero crossover
Supplementary boards	
E00	Hardware configuration
E71	Selecting checkback signal 1
E72	Selecting checkback signal 2 (select signal 0)
E73	Select signal 1
E74	Select signal 2
E75	Suppress parameter
E99	The contents of parameter E99 are dependent on the setting of parameter E73. E99 can only be read via the serial interface, but cannot be changed.

9.2 Parameter description (arranged according to parameter numbers)

P00 Display of the operating statuses (refer to Section 8.1)

P01 Speed setpoint display (terminals 4 and 5)

Nominal display range: -100.0 to 100.0% of the rated input voltage normalized using E01.

Value range (steps): -199 to 199% of n_{max} (0.1%)

P02 Speed actual value display

as a ratio to the maximum speed.

The actual value, selected at parameter P53, is displayed.

Analog output, also refer to P35 = 5 and P37 = 5.

Nominal display range: -100.0 to 100.0% of n_{max}

Value range (steps): -199 to 199% (0.1%)

P03 Armature current setpoint display

as a % of the rated converter current (as absolute value).

Analog output, also refer to P35 = 16 and P37 = 16.

Nominal display range: 0 to 100% of the rated converter current

Value range (steps): 0 to 100% (0.1%)

P04 Armature current actual value display

as a % of the rated converter current (as absolute value)

Analog output, also refer to P35 = 17 and P37 = 17.

Nominal display range: 0 to 100% of the rated converter current

Value range (steps): 0 to 100% (0.1%)

P05 Gating set firing angle display

Value range (steps): 0 to 180 degrees (0.1 degrees)

P06 Current controller integrator display

This is used to check the pre-control setting; 100% indicates a firing angle α deviation of 60°. Analog output, also refer to P35 = 7 and P37 = 7.

Values close to zero are obtained if the pre-control is correctly set.

Value range (steps): 0-100 (0.01)

P07 EMF display (as absolute value)

Analog output, also refer to P35 = 8 and P37 = 8.

Value range (steps): 0 to 999V (1V)

P08 Armature voltage display (as absolute value)

Value range (steps): 0 to 999V (1V)

P09 Analog input display (terminals 6 and 7)

Nominal display range: -100.0 to 100.0% of the rated input voltage, normalized using E02.

Value range (steps): -199 to 999% (0.1%)

P10 RMS supply voltage display

Value range (steps): 0 to 999V (1V)

P11 Speed setpoint, inching 1

Positive values for inching forwards.

Value range (steps): -100 to 100% of n_{max} (0.1%)

Factory setting: 2.0% Change: online

P12 Speed setpoint, inching 2

Positive values for inching forwards.

Value range (steps): -100 to 100% of n_{max} (0.1%)

Factory setting: -2.0% Change: online

P13 Crawl setpointValue range (steps): -100 to 100% of n_{max} (0.1%)

Factory setting: 2.0% Change: online

P14 Inching mode

- 0 The inching setpoints are applied to the ramp-function generator input
- 1 The inching setpoints are applied directly to the speed controller input, bypassing the ramp-function generator

Value range (steps): 0 to 1

Factory setting: 1 Change: offline

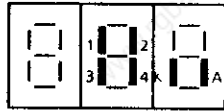
P15 Display, status of the digital inputs and outputs

The status of the digital input terminals or output relay and the binary select output is displayed using bars in the 7-segment display
If the bars are lit → terminal is energized, or the relay has pulled-in.

Bar 1: Terminal 37, on

Bar 2: Terminal 38, operating enable

Bar 3: Terminal 39, digital input 3 (select terminal)

Bar 4: Terminal 40, digital input 4 (select terminal)

Bar K: Relay K3 has pulled-in, terminals 109 and 110 connected

Bar A: Terminal 46, digital select output = high

P16 Ramp-function generator, ramp-up time 1

Value range (steps): 0.00 to 300s (0.01s)

Factory setting: 0s

Change: online

P17 Ramp-function generator, ramp-down time 1

Value range (steps): 0.00 to 300s (0.01s)

Factory setting: 0s

Change: online

P18 Ramp-function generator, initial rounding-off 1

Nominal value, 10% of the ramp-up time.

Value range (steps): 0.00 to 10.0s (0.01s)

Factory setting: 0s

Change: online

P19 Ramp-function generator, final rounding-off 1

Nominal value, 10% of the ramp-up time.

Value range (steps): 0.00 to 10.0s (0.01s)

Factory setting: 0s

Change: online

P20 Actual value filtering

A smoothing of approx. 1 ms is already installed in the hardware.

Value range (steps): 0 to 999ms (1ms)

Factory setting: 3ms

Change: online

P21 Settings for $n < n_{\min}$ signal

Threshold for the line contactor trip for "stop" signal (terminal 37 open).

Value range (steps): 0.0 to 100% of n_{\max} (0.1%)

Factory setting: 0.5 Change: online

P23 Speed threshold, gearbox stage I

(signal n_x)

Value range (steps): 0.0 to 100% of n_{\max} (0.1%)

Factory setting: 100% Change: online

P24 Speed threshold, gearbox stage II

(signal n_x)

Value range (steps): 0.0 to 100% of n_{\max} (0.1%)

Factory setting: 100% Change: online

P27 Speed threshold for the speed controller monitoring

Value range (steps): 0.0 to 60.0% of n_{\max} (0.1%)

Factory setting: 2.0% Change: online

P28 Initial value of the speed controller integrator after controller enable

Value range (steps): -100 to 100% of t_{rated} (1%)

Factory setting: 0% Change: online

P30 Speed controller offset adjustment

Effective for speed control **P89 = 0** and **P89 = 1**. Setting 100 corresponds to approx. 0.6% of speed n_{\max} .

Value range (steps): -100.0 to 100.0% $n_{\max}/163.84$ (1%)

Factory setting: 0 Change: online

P31 Speed controller, P gain

The speed controller becomes a I controller if the gain **P31 = 0**.

Value range (steps): 0.0 to 200 (0.1)

Factory setting: 2.9 Change: online

P32 Speed controller integral action time

The speed controller becomes a P controller if **P32 = 0**.

Value range (steps): 0.00 to 10.0s (0.01s)

Factory setting: 0.62s Change: online

P33 Speed controller P gain, gearbox stage II

Value range (steps): 0.0 to 200 (0.1)

Factory setting: 2.9

Change: online

P34 Speed controller integral action time, gearbox stage II

Value range (steps): 0.00 to 10.0s (0.01s)

Factory setting: 0.62s

Change: online

P35 Assignment, select terminal 14 (analog select output 1)Analog output $\pm 10\text{ V} / 2\text{ mA}$.The normalization, specified in brackets, is valid for $E11 = 1.0$.

Otherwise, the specified analog voltage should be divided by parameter E11 (for SW1.0: P36 instead of E11)

- 0 0 V
- 1 Speed controller setpoint - actual value difference (5 V at max. speed)
- 2 Speed controller output (8 V at rated converter current)
- 3 Absolute current setpoint (8 V at rated converter current)
- 4 Ramp-function generator output (10 V at max. speed)
- 5 Speed at the gearbox output
(8V max. motor speed. For parameterized gearbox ratio, 8V : P72 or 8V : P73)
Speed actual value, if P72 or P73 = 1.00
- 6 Motor utilization (8V at 100% utilization)
$$8\text{V} \times \frac{|EMF_{act}|}{EMF_{set} (= P77)} \times \frac{|I_{act}|}{I_{max} \text{ (actual current limit)}}$$
- 7 Current controller integrator (10V $\approx 5.62^\circ$ firing angle)
- 8 EMF (10V at 510V EMF)
- 9 Diagnostic function (for factory-internal uses)
- 10 Actual current limit (8 V corresponds to the rated converter current)
- 11 Absolute speed actual value (10 V at max. speed)
- 12 Field current setpoint (10V at P76 = 100)
- 13 Torque setpoint (-8V to +8V corresponds to -100% to +100% of the theoretical motor torque at rated converter current, and for a field current, set in P76)
- 14 I²t monitoring (10 V corresponds to the activation point for F13)
- 15 Speed setpoint, directly at the speed controller input
(-10V to +10V corresponds to -100% to +100% of max. speed)
- 16 Current setpoint with sign (8 V corresponds to the rated converter current)
- 17 Current actual value with sign (8 V corresponds to the rated converter current)
- 18 Torque actual value (8 V corresponds to the rated motor torque)

Value range: 0 to 18

Factory setting: 7

Change: online

P36 For supplementary technological board Z14 (from SW4.0)

(for SW1.0: P36 = normalization factor for select terminal 14 (refer to parameter E11))

P37 Assignment, select terminal 16 (analog select output 2)

Analog output $\pm 10\text{ V}/2\text{ mA}$.

The normalization, specified in brackets, is valid for $E12 = 1.0$.

Otherwise, the specified analog voltage should be divided by parameter E12 (for SW1.0: P38 instead of E12).

- 0 0 V
- 1 Speed controller setpoint - actual value difference (5 V at max. speed)
- 2 Speed controller output (8 V at rated converter current)
- 3 Absolute current setpoint (8 V at rated converter current)
- 4 Ramp-function generator output (10 V at max. speed)
- 5 Speed at the gearbox output
(8V max. motor speed. For parameterized gearbox ratio, 8V : P72 and 8V : P73)
Speed actual value, if P72 of P73 = 1.00
- 6 Motor utilization (8V at 100% utilization)
$$8\text{V} \times \frac{|\text{EMF}_{\text{act}}|}{\text{EMF}_{\text{set}} (= P77)} \times \frac{|\text{I}_{\text{act}}|}{\text{I}_{\text{max}} (\text{actual current limit})}$$
- 7 Current controller integrator (10V $\approx 5.62^\circ$ firing angle)
- 8 EMF (10V at 510V EMF)
- 9 Diagnostic function (for factory-internal uses)
- 10 Actual current limit (8 V corresponds to rated converter current)
- 11 Absolute speed actual value (10 V at max. speed)
- 12 Field current setpoint (10V at P76 = 100)
- 13 Torque setpoint (- 8V to + 8V corresponds to - 100% to + 100% of the theoretical motor torque at rated converter current, and for a field current, set in P76)
- 14 i^2t monitoring (10 V corresponds to the activation point for F13)
- 15 Speed setpoint, directly at the speed controller input
(-10V to + 10V corresponds to -100% to + 100% max. speed)
- 16 Current setpoint with sign (8 V corresponds to the rated converter current)
- 17 Current actual value with sign (8 V corresponds to the rated converter current)
- 18 Torque actual value (8 V corresponds to the rated motor torque)

Value range: 0 to 18

Factory setting: 7

Change: online

P38 For supplementary technological board Z14 from SW4.0

(for SW1.0: P38 is the normalization factor for select terminal 16, refer to parameter E12).

Factory setting: 1.0

Change: online,

P39 Positive current limit

Effective for torque direction I. The setting is a % of the rated motor current (P71). The current is automatically limited to the rated converter current!

Value range (steps): 0 to 300% of $I_{\text{mot N}}$ (1%)

Factory setting: 100%

Change: online

P40 Negative current limit (only for 4Q converters)

Effective for torque direction II. The setting is a % of the rated motor current (P71). The current is automatically limited to the rated converter current!

Value range (steps): 0 to 300% of $I_{\text{mot N}}$ (1%)

Factory setting: 100%

Change: online

P41 Positive current limit 2 for torque direction I

This is effective when using the binary input function "current limit changeover". The setting is a % of the rated motor current (P71). The current is automatically limited to the rated converter current!

Value range (steps): 0 to 300% of $I_{mot N}$ (1%)

Factory setting: 100% Change: online

**P42 Negative current limit 2 for torque direction II
(only for 4Q converters)**

This is effective when using the binary input function "current limit changeover". The setting is a % of the rated motor current (P71). The current is automatically limited to the rated converter current!

Value range (steps): 0 to 300% of $I_{mot N}$ (1%)

Factory setting: 100% Change: online

P43 Disable time for anti-stall protection

0 Anti-stall protection disabled

Refer to Section 10.8

Factory setting: 0.5s Change: online

Value range (steps): 0.0 to 60.0s (0.1s)

**P44 Absolute current limit for gearbox stage II
for torque direction MI and MII**

Value range (steps): 0 to 300% of $I_{mot N}$ (1%)

Factory setting: 100% Change: online

P47 Current threshold (I_x)

Value range (steps): 0 to 100% of I_{limit} (1%)

Factory setting: 100% Change: online

P48 Intervention point of the speed-dependent current limiting

Refer to Section 10.4

Factory setting: 100% Change: online

Value range (steps): 0 to 100% of n_{max} (1%)

P49 Current limit at maximum speed (n_{max})

for speed-dependent current limiting.

Refer to Section 10.4

Value range (steps): 0 to 300% of $I_{mot N}$ (1%)

Factory setting: 100% Change: online

P50 Changeover speed

from current limit 1 to current limit 2, if current limit 2 has been selected using one of the select terminals

Value range (steps): 0 to 100% of n_{max} (1%)

Factory setting: 0%

Change: online

P51 Key parameter

0 Standard operation, only the key parameter itself can be changed.
When switching-out the power supply 5U1, 5V1, 5W1, a changeover is always made to P51 = 0.

2 Optimization run for pre-control, current controller and internal adjustments.
Parameters P64 to P68 and L34 are set.

Possible fault messages:

F32: Remanance too high

F86: Discontinuous current limit $> I_{motor}$ (P71)

NOTE

If the optimization run is required, the RAISE key should be depressed after OP = has been displayed. The optimization run is not executed if the LOWER key is depressed.

3 Speed controller optimization run.

Parameters P30, P31 and P33, P34 are set if gearbox stage II is selected.

5 Only for an external field supply unit with field weakening control.
Field characteristic plot: Proceed as for P51 = 2. Converters with field weakening control ($P77 \geq 120$ V), duration up to 2 min. The field characteristic plot is realized at approximately half the EMF setpoint, however, between 90 V and 200 V. Depending on the field weakening range, speeds might occur, which exceed rated speed.

Further, at rated field, a measuring point with 94% of the EMF setpoint (P77) is approached.

Possible fault messages:

F18: Max. measuring point number exceeded, i.e., in spite of maximum field weakening, the maximum speed cannot be reached, or the selected EMF setpoint is too low ($0 < P77 < 120$ V).

F30: Characteristic error, i.e., the measuring points, converted to EMF setpoint, do not result in a useable characteristic (e.g. load surge during field characteristic plotting, analog field current controller at its limit).

The display indicates the EMF, and at each measuring point, the speed actual value for 2 sec.

Before starting the field characteristic plot, set P90 to 2.

After the field characteristic has been successfully plotted, P90 is automatically set to 0 (mixed field mode), and the converter is switched to operating status o7.

20 Standard setting for parameter setting, all parameters can be changed.

30 The parameter list is printed-out. By depressing the MODE key, the short parameter protocol is transferred to a printer via the basic converter serial interface (also refer under P97).

- 31 A once-only parameter list is output at a PG635/PG675/PG685 via the serial interface. Data transfer is started by depressing the MODE key. At the start of data transfer, the machine data ID "%TEA1" and at the end 40x <NUL> is transmitted; otherwise the same data are transferred as for P51 = 30. Data transfer is faster than for P51 = 30 as there are no delay times for carriage return which is the case for printer output.
- 35 Reading-in parameter data from a PG635/PG675/PG685 via the serial interface. The basic converter is brought into the ready condition by depressing the MODE key, which is identified by III, jumping from left to right in the display. The actual data transmission can be identified by the parameter data flashing over the screen.
- 99 All parameters can be changed "ONline". It is possible to read-out the memory contents or output the memory contents at the analog output.

Factory setting: 0



WARNING

Here, all parameters can be changed during operation (ONLINE). This can result in hazardous drive responses.



Thus, the following procedure is highly recommended:

Before setting parameter P51 = 99.

Open-up the connection to the operating enable terminal 38 (L signal). Thus, zero CURRENT is entered and the firing pulses inhibited. Settings can then be made after this, and before entering operating enable, set P51 = 0.

P52 Establish factory setting

Value range (steps): 000-FFF (1 hex)

Factory setting: A50

Change: offline

P53 Speed actual value selection

(also refer to Section 10.14)

0 Main actual value (terminals XT.101 to XT.104)

1 Speed actual value from the pulse encoder

2 EMF actual value, however, evaluated with E33 and E34

Value range: 0 to 2

Factory setting: 0

Change: online

P54 Pulse encoder type

(also refer to Section 10.14)

- 0 No encoder/"speed sensing with pulse encoder" function not selected
 1 Pulse encoder, type 1
 Encoder with two pulse tracks, displaced by 90° (with/without zero mark)



- 2 Pulse encoder, type 2
 Encoder with one pulse track per direction of rotation (with/without zero mark).



- 3 Pulse encoder, type 3
 Encoder with one pulse track and an output for the direction of rotation (with/without zero mark).

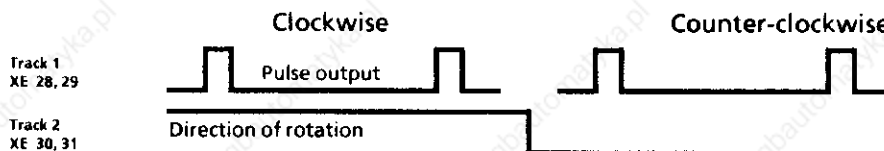

Value range: 0 to 3

Factory setting: 0

Change: offline

P55 Pulse encoder pulse number (thousands)

1 corresponds to 1000 pulses/revolution (lower pulse numbers, refer to P56)

Value range (steps): 0 to 15 (1)

Factory setting: 0

Change: offline

P56 Pulse encoder, pulse number (ones, tens, hundreds)1 corresponds to 1 pulse/revolution (pulse numbers ≥ 1000 , refer to P55)

Value range (steps): 0 to 999 (1)

Factory setting: 0

Change: offline

P57 Pulse encoder control word

Multiple evaluation of the pulse encoder signals

- 0 1 x evaluation of the pulse encoder signals
 1 2 x evaluation of the pulse encoder signals (for encoder types 1 and 2)
 2 4 x evaluation of the pulse encoder signals (for encoder type 1)

Value range: 0 to 2

Factory setting: 0

Change: offline

P58 Maximum speed with the pulse encoder

Thousands-, hundreds- and tens location

The maximum speed is up to 9999.99 RPM. 2 parameters are required to enter this information, as only 3 digits can be entered in each parameter.

Example:

If the maximum motor speed is 7543.16 RPM, then P59 must be set to 316 and P58 to 754.

Caution!

The speed controller optimization run and field characteristic plot must be repeated each time parameter P59 and P58 are changed.

Value range (steps): 0 to 999 (1)

Factory setting: 0

Change: offline

P59 Maximum speed for the pulse encoder

Ones digit and 2 decimal places (refer to P58)

Value range (steps): 0 to 999 (1)

Factory setting: 0

Change: offline

P60 Adaption factor for the speed controller P component

Additional evaluation if ramp-function generator 2 is selected.

Value range (steps): 0.1 to 30.0 (0.1)

Factory setting: 1.0

Change: online

P61 Adaption factor for the speed controller integral action time

Additional evaluation, if ramp-function generator 2 is selected.

Value range (steps): 0.0 to 10.0 (0.1)

Factory setting: 1.0

Change: online

P62 Ramp-up time for reduced gearbox stressing

Is only effective for torque direction change

Value range (steps): 0 to 100ms (1ms)

Factory setting: 0ms

Change: online

P63 Mode for pre-control and current controller

0 Pre-control and current controller functional

1,2 No function

3 Pre-control and current controller inhibited, α_w entered.

4 Pre-control inhibited, current controller enabled

Value range: 0 to 4

Factory setting: 0

Change: offline

P64 Current controller, P gain

Value range (steps): 0.01 to 5.00 (0.01)

Factory setting: 0.16

Change: online

P65 Current controller, integral action time T_n

It is possible to set the integral action time to 0 (results in P controller characteristics).

Value range (steps): 0.0 to 50.0ms (0.1ms)

Factory setting: 25.0ms

Change: online

P66 Pre-control, R components in the discontinuous current range

The parameter is determined at the current controller optimization run.

Value range: 0 to 255

Factory setting: 30

Change: online

P67 Pre-control, R component in the continuous current range

The parameter is determined at the current controller optimization run.

Value range: 0 to 255

Factory setting: 30

Change: online

P68 Discontinuous armature current current

The parameter is determined during the current controller optimization run.

Value range (steps): 0 to 100% of I_{rated} (1%)

Factory setting: 20%

Change: online

P70 Thermal time constant for the motor I^2t monitoringMotor thermal overload protection. F13 appears when the monitoring responds. The monitoring function can be disabled using $P70 = 0$.**NOTE**

The calculated motor pre-loading is lost when the electronics power supply fails. At re-start, it is assumed that the motor is unloaded.

Value range (steps): 0.0 to 180min (0.1min)

Factory setting: 10.0min

Change: offline

P71 Ratio of rated motor current/rated converter currentValue range (steps): 0 to 100% of I_{rated} of the converter (1%)

Factory setting: 80%

Change: offline

P72 Gearbox ratio, stage I

Motor speed / gearbox output speed

Value range (steps): 0.0 to 500 (0.1)

Factory setting: 1.0

Change: online

P73 Gearbox ratio, stage II

Motor speed / gearbox output speed

Value range (steps): 0.0 to 500 (0.1)

Factory setting: 1.0

Change: online

P74 Bus address for G-SST1 (RS232) at X501**from SW 4.0****(or RS485 with supplementary board A1618)**

This parameter is only effective if P97 = 1xx or 2xx (USS protocol) Address via which the unit can be addressed in the USS bus mode.

Factory setting

Value range: 0 to 31,

Change: Offline

P75 Telegram failure time for G-SST1 (RS232) at X501**from SW 4.0****(or RS 485 with supplementary board A1618)**

This parameter is only effective if P97 = 1xx or 2xx (USS protocol)

0 no time monitoring

1 to 32 time which may elapse between the reception of two telegrams addressed for the unit before an error message is output

Factory setting: 0

Value range (steps): 0 to 32s (1s)

Change: Offline

P76 Field current setpoint

P76 = 100 corresponds to 10 V at the analog select output (valid for normalization factor 1.0). This is required for an external controlled field unit (setpoint input).

Value range (steps): 0 to 100 (1)

Factory setting: 1

Change: offline

P77 EMF setpoint at the start of field weakening

Start of field weakening (initiation voltage). P77 = 0 means no field weakening control, i.e. constant field current, which is set with P76. The field weakening control functions above P77 = 120 V for a 380 V supply voltage. The field characteristic should be plotted P51 = 5 for field weakening operation. This is only valid with an external controlled field converter option.

Value range (steps): 0 to 900V (1V)

Factory setting: 0V

Change: offline

P78 EMF controller, P gain (for field weakening)

Value range (steps): 0.01 to 10.0 (0.01)

Factory setting: 0.50

Change: online

P79 EMF controller integral action time Tn (for field weakening)

Value range (steps): 0.00 to 3.00s (0.01s)

Factory setting: 1.00s

Change: online

P80 Mode, binary select output terminal 46, open emitter

0 Fault signal

L: Fault

1 Message " $n < n_{min}$ ", n_{min} is specified by P21H: $n < n_{min}$ 2 Message " $I_A < I_X$ ", I_X is specified by P47, hysteresis E86H: $I_A < I_X$

3 Message "ready", status 01, --, I or II = ready

H: ready

4 Message "run", status --, I or II = run

H: Run

5 Message " $n_{set} = n_{act}$ "H: $n_{set} = n_{act}$

Speed monitoring is an $n_{set} - n_{act}$ comparison directly at the speed controller input, which is effective in all operating statuses. A comparison is made with setpoint zero in all operating statuses other than --, I or II.

Comparison threshold: P27, hysteresis: 2% of n_{max} .

More precisely: Terminal 46 becomes H, if $|n_{set} - n_{act}| < P27$

Terminal 46 again becomes L, if $|n_{set} - n_{act}| \geq P27 + 2\%$ of n_{max}

6 Signal "direction of rotation"; possibility of displaying the polarity of the speed actual value signal

H: Positive actual value (clockwise)

L: Negative actual value (counter-clockwise)

Hysteresis at direction of rotation change can be set using parameter E87.

7 log. "1"

8 log. "0"

9 "Ready to switch-on" signal

H: Ready to switch-on from SW4.0

Transition from low to high approximately 50 ms after the reset status has been withdrawn in the microprocessor (when switching-on the power supply voltage).

Value range: 0 to 8

Factory setting: 0

Change: offline

P81 Auto-reversing stage mode

0 Auto-reversing stage functional.

Response sensitivity for the torque direction is permanently set.

Standard setting for converters with 4-quadrant operation.

1 Torque direction M I inhibited. If a setpoint is entered, for which the torque direction is inhibited, P00 = -- is indicated in the operating display.

2 Torque direction M II is inhibited.

Value range: 0 to 2

Factory setting: 2 for 1Q converters
0 for 4Q converters

Change: offline

P83 Selecting the function of terminal 39 (binary select input 1)

Functions, refer to "List of binary input functions" (Section 10.2)

Value range: 0 to 25
0 to 26 from SW4.0

Factory setting: 0 Change: offline

P84 Selecting the function of terminal 40 (binary select input 2)

Functions, refer to "List of binary input functions" (Section 10.2)

Value range: 0 to 25
0 to 26 from SW4.0

Factory setting: 0 Change: offline

P85 Assignment of select terminals 6 and 7 (analog select input)

Analog input ± 10 V, (normalization: Parameter E02)

- 0 No function
- 1 Supplementary setpoint, speed controller
Caution: The sum of the ramp-function generator output and supplementary setpoint, speed controller (this acts after the ramp-function generator), is limited to 105% of the maximum speed.
- 2 Supplementary setpoint, current controller
The connected analog value is added as additional current setpoint (referred to the rated converter current) after the torque limiting.
- 3 No function
- 4 No function
- 5 External current limiting for the positive and negative current directions. (negative current direction only effective for 4 Q converters).
The reference value is the higher of the 2 limit values of P39 and P40. This reference value is multiplied by the absolute normalized value of the analog input, terminals 6, 7, and the resulting adjustable limit dominates with respect to the limit values parameterized at P39 to P42 and P44 (value range limited to 0 to 100%, i.e. the current limit value can only be reduced).
- 6 No function
- 7 External current limiting with sign for the positive current direction (master-slave applications) (only practical for 4 Q converters).
The reference value is the higher of the two limit values of P39 and P40. This reference value is multiplied with the normalized value of the analog input, terminals 6, 7 and the resulting controllable limit dominates with respect to the limit values parameterized at P39, P41 and P44 (value range limited to -100 to 100%, i.e. the current limit value can only be reduced).
A positive value after E02 normalization acts as current limit in torque direction I ; in torque direction II , the unchanged parameter values P40, P42 and P44 are effective.
A negative value after E02 normalization results in a lower current limit in torque direction II, and the highest current values in torque direction II are defined, unchanged, by parameter values P40, P42 and P44.

NOTE

When parameter P85 is either set to 7 or 8, negative values at terminal 8 act as current setpoints for the opposite torque direction. The motor can accelerate in the opposite direction, even for speed setpoint zero.

- 8 External current limit, with sign, for negative current direction (only practical for 4Q converters).
The reference value is the higher of the two limit values of P39 and P40. This reference value is multiplied with the normalized value of the analog input, terminals 6, 7, and the resulting controllable limit dominates over limit values parameterized at P40, P42 and P44 (value range limited to -100 to 100%, i.e. the current limit value can only be reduced).
A positive value after E02 normalization acts as current limiting in direction II, and in torque direction I, the unchanged parameter values P39, P41 and P44 are effective. A negative value after E02 normalization acts as lower current limit in torque direction I, the highest current values in torque direction I are determined, unchanged, from parameter values P40, P42 and P44.
- 9 Analog field current setpoint
The absolute analog value can be output via an analog select output, e.g. as field current setpoint. The converter-internal EMF controller is in this case, disabled, automatic field weakening is not possible. Parameterization of the analog select output: P35 and P37 = 12.
Normalization, field current setpoint: P76
- 10 No function
- 11 Current setpoint for the following drive (refer to Section 10.2.11)
- 12 Supplementary speed setpoint before the ramp-function generator
The sum of the main setpoint and supplementary setpoint are limited to 105% of $n_{\max} \cdot 10V = 100\% n_{\max}$, for E02 = 100

Value range: 0 to 12

Factory setting: 0

Change: offline

P86 Mode for analog output terminal 12 I_{act}

Current actual value display (either as absolute value or output with sign, $\pm 10 V/2 mA$)
10 V corresponds to the rated converter current.

- 0 Current actual value display with sign: Positive = torque direction I
- 1 Absolute current actual value is displayed
- 2 Inverted current actual value is displayed with sign
- 3 Absolute current actual value, inverted

Value range: 0 to 3

Factory setting: 0

Change: offline

P87 Selecting the restart mode and software write protection

Converter behavior after a supply failure can be defined using the ones digit of parameter P87:

- Converter is tripped until the supply fault has been acknowledged,
- Automatic restart after supply failure (for safety reasons, for supply failures up to 1 s),
- Acknowledgement of the supply failure fault at the converter,
- Acknowledgement of the supply failure fault via terminal 37 (switch-on).

Write protection can be parameterized using the tens digit of parameter P87 to secure the permanent memory (EEPROM) per software: P87 = 0x. With parameterization P87 = 00 and P87 = 02 (i.e. software write protection and no automatic restart), or when hardware write protection is inserted, when the supply fails completely, the supply fault cannot be stored, and after the supply returns, the converter goes into operating status o7 "ready to switch-on", which can be acknowledged by a high → low → high transition at terminal 37 (shutdown/switch-on).

- x0 The converter is immediately shutdown when the supply voltage fails, fault message F04 is output and stored.
Fault acknowledgement:
 The fault message must be acknowledged at the converter so that it can be restarted.
- x1 Supply voltage failure < approx. 1 s.
 Automatic restart when the supply voltage returns, no fault message.
 Supply voltage failure longer than approx. 1 s.
 The converter is shutdown, fault message F04 is output and stored.
Fault acknowledgement:
 The fault message must be acknowledged at the converter so that restart is possible.
- x2 The converter is immediately shutdown when the supply voltage fails, fault message F04 is output and stored.
Fault acknowledgement:
 The fault can be acknowledged and the converter switched-on again using a high → low → high transition at terminal 37 (shutdown/switch-on).
 (It is not necessary to acknowledge at the converter itself. The fault display is however retained, and must be cancelled at the converter at a later stage.)

The following faults can be acknowledged

- F04 Phase failure, line fuse
 F05 Undervoltage
 F12 Current actual value > 300% of the rated converter current
 F13 I²t monitoring responded (motor too hot)
 F14 External fault

- x3 Supply voltage failure < approx. 1 s
 Automatic restart when the supply voltage returns, no fault message.
 Supply voltage failure longer than approx. 1 s
 The converter is shutdown, fault message F04 output and stored.
Fault acknowledgement: As described under P87 = x2.
- 0x Protection against changes in the non-volatile memory (EEPROM).
 Faults are not stored.
 If parameter values are changed, these are only stored in the volatile RAM, and are valid for the converter, as long as the electronics power supply voltage is not switched-off.
 The original data stored in the EEPROM are used after the electronics power supply is switched-out.
 Exception: Parameters P87 and P52 are immediately transferred into the non-volatile memory at each change.
 Fault message F34 ("EEPROM fault") is not effective with this setting. Further, hardware write protection can be inserted (electronics board A1660, plug-in jumper XJ1 in setting 2-3), no changes are stored in the EEPROM.
- 1x Same function as setting 0x
 2x Same function as setting 0x
 3x Each parameter change and fault message is immediately transferred into the non-volatile EEPROM memory. The monitoring function of the non-volatile memory is effective.

Value range (steps): 00 to 33 (1 Hex)

Factory setting: 33

Change: online

P88 Selecting the mode for automatic field current reduction

Only used for the external field supply converter option.

- 0 The field current setpoint, set at parameter P76, is not automatically reduced. Full field at standstill (P76 value).
- 1 Automatic field current reduction (standstill excitation):
The field current is reduced to the value set in parameter P96 (% of P76), 10 s after the line contactor is de-energized via relay K3 of the SIMOREG converter (stop, off or fault condition). When the line contactor is switched-in again via the relay, the field current setpoint, set at parameter P76, is automatically set.
- 2 The field current setpoint, set at parameter P76, is only switched-in in the "ready" and "run" statuses (i.e. the field current is switched the same as K3 is energized).

Value range: 0 to 2

Factory setting: 1

Change: offline

P89 Speed controller mode

One's location:

- x0 The PI controller is functional (standard setting)
- x1 Speed controller is enabled, however, only as P controller
- x2 No function
- x3 The speed controller is inhibited. The main setpoint is interpreted as current setpoint. A positive setpoint corresponds to torque direction I. The ramp-function generator remains effective.

Ten's location:

The speed controller integral action time P32 can be multiplied by a factor when the ramp-function generator is running. This factor can be set via the ten's location of parameter P89. The speed controller acts like a P controller during the run-up (speed overshoot is reduced).

- 0x Factor 1 (i.e. function disabled)
- 1x Factor 1000

Value range (steps): 00 to 13 (1 hex)

Factory setting: 00

Change: offline

P90 Field weakening control mode

Only for an external field supply unit.

Field weakening starts at the EMF, set in P77. Constant field current is output without field weakening control, P77 = 0.

- 0 Standard operating mode for closed-loop EMF control, field pre-control plus closed-loop EMF control (value after the field characteristic plot).
- 1 Speed - pre-controlled field
- 2 EMF - controlled field without pre-control

Value range: 0 to 2

Factory setting: 2

Change: offline

P91 Disabling monitoring functions / suppressing fault messages

(also refer to Section 10.13)

Every individual monitoring function which can be disabled, is assigned a bit in a control register (parameter 91). The required bit pattern must be entered in hexadecimal format. The conversion table in Section 10.13 can be used to define the HEX number.

Bit No.	11	10	9	8	7	6	5	4	3	2	1	0
Error No.	F26	F19		F16	F12	F07	F11	F05	F04	F03	F02	F23
Example	1	1	0	0	0	0	1	0	0	1	0	0
	Hundreds				Tens				Ones			
	C				2				4			

from P91

*) from SW4.0

Disconnecting additional monitoring functions (also refer to P92)

F10 (Overspeed protection) can be disabled via parameter E21 = 0.

F13 (I²t monitoring) can be disabled via parameter P70 = 0.

F14 (External fault) can be disabled via parameter P83 and P84 ≠ 15.

F15 (Speed controller monitoring) can be disabled via parameter E03 = 1x.

F16 (Anti-stall protection) can also be disabled via parameter P43 = 0.

F34 (EEPROM fault) can be disabled via parameter P87 = x1 or x2 (permanent memory inhibit active)

Value range: 000 to FFF (1 hex)

Factory setting: 0

Change: offline

P92 Disabling monitoring functions / suppressing fault messages

(reserved for use later)

Every individual monitoring function which can be disabled is assigned a bit in a control register (parameter 92). The required bit pattern must be entered in the hexadecimal format. The conversion table in Section 10.13 can be used to determine the HEX number.

Bit No.	11	10	9	8	7	6	5	4	3	2	1	0
Error No.	F	F	F	F	F	F	F	F	F	F	F	F
Example												
	Hundreds				Tens				Ones			

from P92

Value range: 000 to FFF (1 hex)

Factory setting: 0

Change: offline

P93 Rated supply voltage / output (according to the rating plate)

- 1 400V (the same function as for setting 2)
- 2 400V
- 3 500V

Value range: 1 to 3

Factory setting: Is not overwritten for "establish factory setting"

Change: offline

P94 Gating unit, rectifier stability limit alpha G

Value range (steps): 0 to 180° (1°)

Factory setting: 5° for 1Q converters Change: offline
30° for 4Q converters

P95 Gating unit, inverter stability limit, alpha W

Value range (steps): 0 to 180° (1°)

Factory setting: 150° Change: offline

P96 Standstill field current

The setting refers to the value set in P76.

Only valid when an external field supply unit is used.

Value range (steps): 0 to 100 (1)

Factory setting: 0 Change: online

P97 Control parameters for the serial interfaceProtocol

0xx Function can be selected via P51

1xx USS protocol, short telegram (from SW4.0)

2xx USS protocol, long telegram (from SW4.0)

USS-protocol selection becomes effective after changing over into the P mode.

Data transmission format

For USS protocol (P97 = 1xx or 2xx), the setting of the tens units is irrelevant. The data transfer format is always set to 11-bit frames with 1 start bit, 8 data bits + 1 parity bit, 1 stop bit, even parity.

- x0x 10-bit frame
(1 start bit, 8 data bits, 1 stop bit) no parity
- x1x 10 bit frame
(1 start bit, 7 data bits + 1 parity bit, 1 stop bit) even parity
- x2x 11 bit frame
(1 start bit, 9 data bits, 1 stop bit) no parity
- x3x 11 bit frame
(1 start bit, 8 data bits + 1 parity bit, 1 stop bit) even parity

Baud rate (asynchronous)

- xx0 300 baud
- xx1 600 baud
- xx2 1200 baud
- xx3 2400 baud
- xx4 4800 baud
- xx5 9600 baud

xx6 19200 baud
 xx7 38400 baud
 from SW4.0
 xx8 76800 baud
 for SW1.0:
 xx8 93750 baud
 xx9 187500 baud

Value range: 000 to 239 (1 hex)

Factory setting: 135

Change: offline

P98 Voltage adaption for the electronics power supply

Adaption factor for the armature circuit supply voltage.

$P98 = 400 \times \bar{u}$

$P98 = 400$ (for 400 V supply voltage at the power section)

$$\bar{u} = \frac{\text{Supply voltage at the power section}}{400V}$$

Value range (steps): 0 to 900V (1V)

Factory setting: Is not overwritten for "establish factory setting"

Change: offline

P99 Converter version and software release setting

The software release is indicated using parameter P99. Further, at the first location (hundreds):

1x.x SIMOREG 1Q (6RA23xxxxS2x)

2x.x SIMOREG 4Q (6RA23xxxxV6x)

E00 Hardware configuration

0 SIMOREG basic converters without supplementary boards

The option boards can be used from version 10 of the basic converter board C98130-A1660, in this case the following is valid:

1 to 7 No function

8 Basic converter with a supplementary board coupled via a dual port RAM, transmission of a 4-word protocol.

9 Basic converter with a supplementary board coupled via a dual port RAM, transfer of a 10-word protocol

A,b,C,d,E Free for later use

F No function

Value range: 000 to FFF (1 hex)

Factory setting:

Change: online

E01 Normalization, main setpoint (terminals 4 and 5)

Parameter E01 is used to determine which of the analog main setpoint voltages is used to generate a converter-internal signal level of 100%.

$$E01 = 10 \times \text{main setpoint voltage [V]}$$

The polarity can be adapted with negative values of E01.

Value range (steps): -199 to 999 (1)

Factory setting: 100

Change: online

E02 Normalization for the analog select input (terminals 6 and 7)

Parameter E02 is used to determine which of the analog voltages at terminals 6 and 7 is used to generate a converter-internal signal level of 100%.

$$E02 = 10 \times \text{voltage value [V]}$$

Polarity adaption can be realized with negative values of E02.

Value range (steps): -199 to 999 (1)

Factory setting: 100

Change: online

E03 Selecting the filter type and activating the speed controller monitoringFilter type selection

x0 Speed actual value filtering via 1st order filter. Filter time constants can be set using parameter P20.

x1 The speed controller input (speed actual value) is fed through a bandstop, second order filter, which can be set via parameters E04 to E06 (P20 is ineffective).

Disabling the speed controller monitoring

0x Monitoring active

1x Monitoring disabled (fault F15 suppressed)

Value range: 00 to 11 (1 hex)

Factory setting: 10

Change: offline

E04 Suppression quality of the bandstop filter

0 Quality of the bandstop filter = 0.5

1 Quality of the bandstop filter = 1

2 Quality of the bandstop filter = 2

3 Quality of the bandstop filter = 3

Value range: 0 to 3

Factory setting: 0

Change: online

E05 Resonant frequency of the bandstop filter

(only for E03 = x1)

(Setting: 0 to 7 → bandstop filter not active)

Value range (steps): 0 to 140Hz (1Hz)

Factory setting: 0Hz

Change: online

E06 Resonant frequency of the bandstop filter for gearbox ratio, stage II

(only for E03 = x1)

(Setting: 0 to 7 → bandstop filter not active)

Value range (steps): 0 to 140Hz (1Hz)

Factory setting: 0Hz

Change: online

E11 Normalization factor for select terminal 14 (analog select output 1)

from SW4.0,

Value range (steps): -0.0 to 9.9 (0.1)

Factory setting: 1.0

Change: Online

(for SW1.0, normalization factor is P36)

E12 Normalization factor for select terminal 16 (analog select output 2)

from SW4.0

Value range (steps): -9.9 to 9.9 (0.1)

Factory setting: 1.0

Change: Online

(for SW 1.0: normalization factor is P38)

E16 Ramp-function generator, ramp-up time 2

This is only effective, if ramp-function generator 2 is selected via a binary select input, or via the control word (observe P60 and P61).

Value range (steps): 0.00 to 300s (0.01s)

Factory setting: 0s

Change: online

E17 Ramp-function generator, ramp-down time 2

Only effective, if ramp-function generator 2 is selected via a binary select input or via the control word (observe P60 and P61).

Value range (steps): 0.00 to 300s (0.01s)

Factory setting: 0s

Change: online

E18 Ramp-function generator, initial rounding-off 2

This is only effective, if ramp-function generator 2 is selected via a binary select input or via the control word (observe P60 and P61).

Value range (steps): 0.00 to 10.0s (0.01s)

Factory setting: 0s

Change: online

E19 Ramp-function generator, final rounding-off 2

This is only effective, if ramp-function generator 2 is selected via a binary select input, or via the control word (observe P60 and P61).

Value range (steps): 0.00 to 10.0s (0.01s)

Factory setting: 0s

Change: online

E20 Selecting the mode for the motorized potentiometer function

- 0 The speed setpoint is not stored when the converter is shutdown (OFF1, fast stop, or when a monitoring function responds).
- 1 Storing the last speed setpoint

Value range: 0 to 1

Factory setting: 0

Change: offline

With digital interface, motorized potentiometer operation is possible via control word.

E21 Response threshold for overspeed signal F10

(0: overspeed message is suppressed)

Value range (steps): 0 to 150% of n_{max} (1%)

Factory setting: 120%

Change: online

E33 IxR compensation of the measured V_d

The factor "current actual value x E33" is subtracted from the output voltage (instead of a tachometer).

Value range (steps): -30 to 30% from V_{Arated} at I_{Arated} (0.1%)

Factory setting: 0.0%

Change: online

E34 Maximum speed for operation without tachometer (EMF = speed actual value)

When the internal EMF actual value is used as speed actual value, speed adjustment is made using this parameter. The parameter specifies the maximum speed as a percentage of P98.

Value range (steps): 0.01 to 120% (0.01%)

Factory setting: 100%

Change: online

E39 Thyristor check

- 0 Thyristor check disabled
- 1 Thyristors are checked at first switch-on (terminal ON or inching) after the supply voltage has been established.
- 2 Thyristors are checked at each switch-on via terminal ON or inching.
- 3 Thyristors are checked at each switch-on via terminal ON or inching. If no faulty thyristor is identified, the drive continues to run, and parameter E39 is automatically set to 0.
The faulty thyristor or the faulty thyristor module is indicated via fault messages F41 to F76.
The test routine is 5 s long.

Value range: 0 to 3

Factory setting: 0

Change: offline

E41 Changeover threshold P/PI speed controller

For speeds less than E41, P controller characteristics are selected, depending on the speed actual value. PI controller characteristics are re-selected for $n_{act} > E41 + 2\%$. This allows the drive to be shutdown, jolt-free, only via the speed setpoint ($n_{set} \rightarrow 0$), without removing the ON/stop signal (the motor remains in closed-loop speed control operation).

This function is disabled for $E41 = 0$ (as supplied).

Value range (steps): 0.0 to 10.0% of n_{max} (0.1%)

Factory setting: 0.0%

Change: online

NOTE

It is possible to change over from PI to P controller characteristics via the gearbox stage selection (select function, refer to P83 and P84), if the I component of the selected speed controller is set to 0, i.e. the integral action time of the appropriate gearbox stage is 0.

E60 Droop

This acts on the speed controller. 10% droop means that the speed actual value deviates by 10% from the maximum speed at the setpoint when the drive is loaded at rated converter current.

Droop function (analog equivalent circuit diagram)

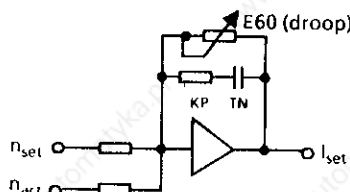

Value range (steps): 0 to 10.0% (0.1%)

Factory setting: 0.0

Change: online

E61 Setpoint reduction

If one of the binary select terminals is parameterized as setpoint reduction, when the terminal is energized, the setpoint at the ramp-function generator input is limited to the value set at parameter E61 (% of n_{max} , max. speed limiting).

Value range (steps): 0.0 to 100% of n_{max} (0.1%)

Factory setting: 100%

Change: online

E68 Torque limiting (refer to Section 10.10)

Value range (steps): 0 to 300% of $M_{mot N}$ (1%)

Factory setting: 300%

Change: online

E70 Selecting the mode for closed-loop torque control (refer to Section 10.10)

- x0 Closed-loop current control
- x1 Closed-loop torque control (i.e. the speed controller output is divided by the actual magnetic motor flux)
- 0x Analog limit via analog select terminal acts as current limiting
- 1x Analog limiting via analog select terminal acts as torque limiting (if closed-loop torque control is parameterized)

Value range: 00 to 11 (1 hex)

Factory setting: 00

Change: offline

Closed-loop torque control in field-weakening operation is possible with an external, controlled field converter.

E71 Selecting checkback signal 1

The significance of bits 5, 6 and 7 of the low byte of the status word (word S3 for the dual port RAM interface), signaled back via the interface, can be selected via parameter E71 ("selecting checkback signal 1").

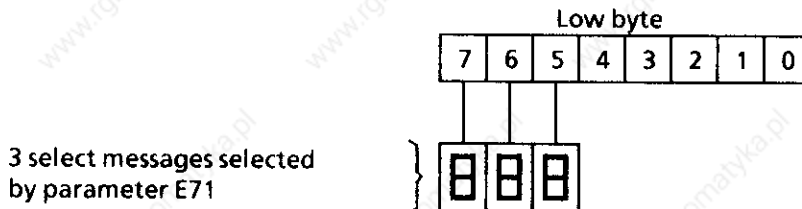

- 0 Delete appropriate bit
- 1 $I_A > I_X$
- 2 $n < n_X$
- 3 $I^2t > 90\%$
- 4 $n_{set} = n_{act}$
- 5 Ready: Drive responds to controller enable (operating status o1, I, II, --)
- 6 Fault (group message)
- 7 One or several of the current limits B + , B- , B1 + , B1- , B2 + , B2- , B3 + , B3- have been reached
- 8 Status of terminal 38 is signaled
- 9 "Speed controller monitoring" message is signaled
- A "Drive is ready" is signaled
- b The direction of rotation is signaled
 - L: Positive speed actual value (clockwise rotation)
 - H: Negative speed actual value (counter-clockwise rotation) from SW4.0.

Value range: 000 to FFF (1 Hex)

Factory setting:

Change: online

E72 Selecting checkback signal 2 (select signal 0)

(word S2 for the dual port RAM interface or S5 for USS protocol at GSS-T1)

- 0 The speed actual value used (selected via P53) is signaled back via the interface
- 1 The current actual value is signaled back via the interface
- 2 Select signal 1 (can be selected via E73) is signaled back
- 3 The analog speed actual value is signaled back via the interface
- 4 The pulse encoder actual value is signaled back via the interface
- 5 The armature voltage, evaluated with E33 and E34 is signaled back via the interface

Value range (steps): 0 to 5 (1 hex)

Factory setting: 0

Change: online

E73 Select signal 1

(word S7 for the dual port RAM interface or S8 for the USS protocol at GSS-T1)

All analog signals, which can be selected via parameter P35 can be signaled back and also via the interface. Parameter E73 is used to select the signals to be signaled back. The value selected at E73 is also written into E99 (is not stored in the EEPROM). For short telegrams, the selected value can be read via the parameter interface.

- 0 0
- 1 Setpoint-actual value difference of the speed controller
(-16384 to 16384 = -100 to 100% of n_{max})
- 2 Speed controller output
(-25600 to 25600 = -100 to 100% of the rated converter current)
- 3 Absolute current setpoint value
(3200 = 100% of the rated converter current)
- 4 Ramp-function generator output
(-16384 to 16384 = -100 to 100% of n_{max})
- 5 Speed actual value (can be normalized via P72)
(-16384 to 16384 = -125 to 125% of n_{max})
- 6 Motor utilization (32767 = 125% utilization)
(100% utilization means that the drive is operating at its presently effective current limit with the EMF according to P76)
- 7 Current controller integrator
The value is added for pre-control and the sum limited to α_G
(-32767 to 32767 = -180° to 180° firing angle)
- 8 EMF (in volt)
- 9 Diagnostic function
Contents of the byte specified by parameter L00 (L byte of the address) and L01 (H byte of the address).
- 10 Actual current limit
Checkback signal for the current possible for the actual operating point
(absolute value: 3200 = 100% of the rated converter current)
- 11 Absolute speed actual value
(16384 = 100% of n_{max})
- 12 Field current setpoint
(255 = 100% of P76)
- 13 Torque setpoint (m x sequence)
(-25600 to 25600 = -100 to 100%)
The rated torque is the torque at rated converter current and at the field current set to the value in P76.
- 14 I²t monitoring
(16384 = trip point for F13)
- 15 Speed setpoint directly at the speed controller input
(-16384 to 16384 = -100 to 100% of n_{max})
- 16 Current setpoint with sign
(-3200 to 3200 = -100 to 100%)
- 17 Current actual value with sign
(-3200 to 3200 = -100 to 100%)
- 18 Torque actual value
(-25600 to 25600 = -100 to 100%)
The rated torque is the torque at rated converter current and at the field current set to the value in P76.

Value range: 0 to 18

Factory setting: 0

Change: online

E74 Select signal 2

The same functions as for parameter E73 can be signaled back via the interfaces (word S8 for the dual port RAM interface or S9 for the USS protocol at G-SST1).

Value range: 0 to 18

Factory setting: 0

Change: online

E75 Suppression parameters

Bit No.:

	0 ...	Setpoint from the basic converter
	1 ...	Setpoint from the interface (word E2 for the dual port RAM interface or E5 for the USS protocol at G-SST1)
1	0 ...	Field current setpoint from the basic converter
	1 ...	Field current setpoint from the interface (byte E6a for dual port RAM interface or byte E7a for the USS protocol at G-SST1)
2	0 ...	Current limit from the basic converter
	1 ...	Current limit from the interface (words E7 and E8 for the dual port RAM interface or word E8 and E9 for the USS protocol at G-SST1)
3		Unassigned bit, no function
4	0 ...	Speed actual value from the basic converter
	1 ...	Speed actual value from the interface (word E9 for dual port RAM interface or word E10 for the USS protocol at G-SST1)
5	0 ...	Control word
	1 ...	Control word suppressed, the converter is only controlled via terminals. Exception: The bit fault acknowledgement is active.

Value range (steps): 00 to 3F (1 hex)

Factory setting: 20

Change: online

E86 Hysteresis for signals $n < n_x$, $I_A > I_x$

Setting for $n < n_x$

x0 ...	0.5% of n_{max}
x1 ...	1.0% of n_{max}
x2 ...	2.0% of n_{max}
x3 ...	3.0% of n_{max}
x4 ...	4.0% of n_{max}
x5 ...	5.0% of n_{max}
x6 ...	6.0% of n_{max}
x7 ...	7.0% of n_{max}
x8 ...	8.0% of n_{max}
x9 ...	9.0% of n_{max}
xA ...	0.1% of n_{max}
xB ...	0.2% of n_{max}
xC ...	0.3% of n_{max}
xD ...	0.4% of n_{max}

Setting for $I_A > I_x$

0x ...	0.5% of I_{limit}
1x ...	1.0% of I_{limit}
2x ...	2.0% of I_{limit}
3x ...	3.0% of I_{limit}
4x ...	4.0% of I_{limit}
5x ...	5.0% of I_{limit}
6x ...	6.0% of I_{limit}
7x ...	7.0% of I_{limit}
8x ...	8.0% of I_{limit}
9x ...	9.0% of I_{limit}

Value range (steps): 00 to 9D (1 hex)

Factory setting: 84

Change: online

E87 Hysteresis for the "direction of rotation" signal

Value range (steps): 0.0 to 10.0% (0.1%)

Factory setting: 0.1%

Change: online

E99 The contents of parameter E99 are dependent on the setting of parameter E73. E99 can only be read via the interface, however, not changed.

H parameters reserved for supplementary technological board Z14.

The L parameters appear after the last H parameters. These can be used to read-out values stored in the EEPROM, and to some extent, change them, which are normally only internally used, or are written into during the field characteristic plot and optimization run (L08 to L34).

A-L Diagnostic address, low byte

Value range (steps): 00 to FF (1hex)

Factory setting: 00

Change: online

A-H Diagnostics address, high byte

Value range (steps): 00 to FF (1hex)

Factory setting: C0

Change: online

≡ - ≡ Contents of the diagnostic memory location

Value range (steps): 00 to FF (1hex)

SHI Number of shifts for the analog diagnostic function

Value range: 1 - 15

Factory setting: 0

Change: online

L04 Various flag bits

Value range (steps): 00 to FF (1hex)

Factory setting: 01

L05 Last fault

Value range (steps): 00 to 99 (1hex)

Factory setting: 00

Change: offline

L06 Ramp-function generator output display for the motorized potentiometer

(in conjunction with supplementary boards)

Value range (steps): -105 to 105% (0.1%)

L07 Display, EMF / n_{act} normalized

Value range (steps): 0 to 999 (0.01)

L08 Flag, "field characteristic plotted"

Value range (steps): 0 to 1 (1 Hex)

Factory setting: 0

Change: offline

L09 EMF setpoint at the changeover speed

Value range (steps): 0 to 999V (1V)

Factory setting: 340V

Change: offline

L10 Speed at which field weakening starts

(speed at the EMF according to L09 and 100% rated motor field current)

Value range (steps): 0 to 199% of n_{max} (1%)

Factory setting: 100%

Change: offline

L11 1st characteristic point for the field characteristic

(speed at the EMF according to L09 and 84.7% rated motor field current)

Value range (steps): 0 to 199% of n_{max} (0.1%)

Factory setting: 199%

Change: offline

L12 2nd characteristic point

(speed at the EMF according to L09 and 71.8% rated motor field current)

Value range (steps): 0 to 199% of n_{max} (0.1%)

Factory setting: 199%

Change: offline

L13 3rd characteristic point

(speed at the EMF according to L09 and 60.8% rated motor field current)

Value range (steps): 0 to 199% of n_{max} (0.1%)

Factory setting: 199%

Change: offline

L14 4th characteristic point

(speed at the EMF according to L09 and 51.4% rated motor field current)

Value range (steps): 0 to 199% of n_{max} (0.1%)

Factory setting: 199%

Change: offline

L15 5th characteristic point

(speed at the EMF according to L09 and 43.5% rated motor field current)

Value range (steps): 0 to 199% of n_{max} (0.1%)

Factory setting: 199%

Change: offline

- L16 6th characteristic point**
(speed at the EMF according to L09 and 36.9% rated motor field current)
Value range (steps): 0 to 199% of n_{max} (0.1%)
Factory setting: 199% Change: offline
- L17 7th characteristic point**
(speed at the EMF according to L09 and 31.0% rated motor field current)
Value range (steps): 0 to 199% of n_{max} (0.1%)
Factory setting: 199% Change: offline
- L18 8th characteristic point**
(speed at the EMF according to L09 and 26.3% rated motor field current)
Value range (steps): 0 to 199% of n_{max} (0.1%)
Factory setting: 199% Change: offline
- L19 9th characteristic point**
(speed at the EMF according to L09 and 22.4% rated motor field current)
Value range (steps): 0 to 199% of n_{max} (0.1%)
Factory setting: 199% Change: offline
- L20 10th characteristic point**
(speed at the EMF according to L09 and 18.8% rated motor field current)
Value range (steps): 0 to 199% of n_{max} (0.1%)
Factory setting: 199% Change: offline
- L21 11th characteristic point**
(speed at the EMF according to L09 and 16.1% rated motor field current)
Value range (steps): 0 to 199% of n_{max} (0.1%)
Factory setting: 199% Change: offline
- L22 12th characteristic point**
(speed at the EMF according to L09 and 13.3% rated motor field current)
Value range (steps): 0 to 199% of n_{max} (0.1%)
Factory setting: 199% Change: offline
- L23 13th characteristic point**
(speed at the EMF according to L09 and 11.4% rated motor field current)
Value range (steps): 0 to 199% of n_{max} (0.1%)
Factory setting: 199% Change: offline

L24 14th characteristic point

(speed at the EMF according to L09 and 9.8% rated motor field current)

Value range (steps): 0 to 199% of n_{\max} (0.1%)

Factory setting: 199%

Change: offline

L25 15th characteristic point

(speed at the EMF according to L09 and 8.2% rated motor field current)

Value range (steps): 0 to 199% of n_{\max} (0.1%)

Factory setting: 199%

Change: offline

L26 16th characteristic point

(speed at the EMF according to L09 and 7.1% rated motor field current)

Value range (steps): 0 to 199% of n_{\max} (0.1%)

Factory setting: 199%

Change: offline

L27 17th characteristic point

(speed at the EMF according to L09 and 5.9% rated motor field current)

Value range (steps): 0 to 199% of n_{\max} (0.1%)

Factory setting: 199%

Change: offline

L28 18th characteristic point

(speed at the EMF according to L09 and 5.1% rated motor field current)

Value range (steps): 0 to 199% of n_{\max} (0.1%)

Factory setting: 199%

Change: offline

L29 19th characteristic point

(speed at the EMF according to L09 and 4.3% rated motor field current)

Value range (steps): 0 to 199% of n_{\max} (0.1%)

Factory setting: 199%

Change: offline

L30 20th characteristic point

(speed at the EMF according to L09 and 3.5% rated motor field current)

Value range (steps): 0 to 199% of n_{\max} (0.1%)

Factory setting: 199%

Change: offline

L31 2x number of valid characteristic points

Value range: 0 to 40

Factory setting: 0

Change: offline

L32 Minimum field current at n_{max} [255 = rated field current (P76)]

Value range: 0 to 255

Factory setting: 13

Change: offline

L33 Supply frequency tracking / response threshold F11Frequency tracking

- x0 Stiff supplies
- x1 Weak supplies, very slow frequency tracking
- x2 Weak supplies, slow frequency tracking
- x3 Weak supplies, fast frequency tracking

Monitoring function for tachometer cable interruption

Increases the response threshold for the monitoring function for tachometer cable interruption (F11)

- 0x Response threshold 60V x P98 / 400
- 1x Response threshold 120V x P98 / 400
- 2x Response threshold 180V x P98 / 400
- 3x Response threshold 240V x P98 / 400

Value range (steps): 00 to 33

Factory setting: 00

Change: online

L34 Offset to the supply zero crossover

This is automatically set at the optimization run.

Value range (steps): -199 to 199 x 10 μ s

Factory setting: 0

Change: online

10. Functions

10.1 Function diagrams

Sheet 1 Overview

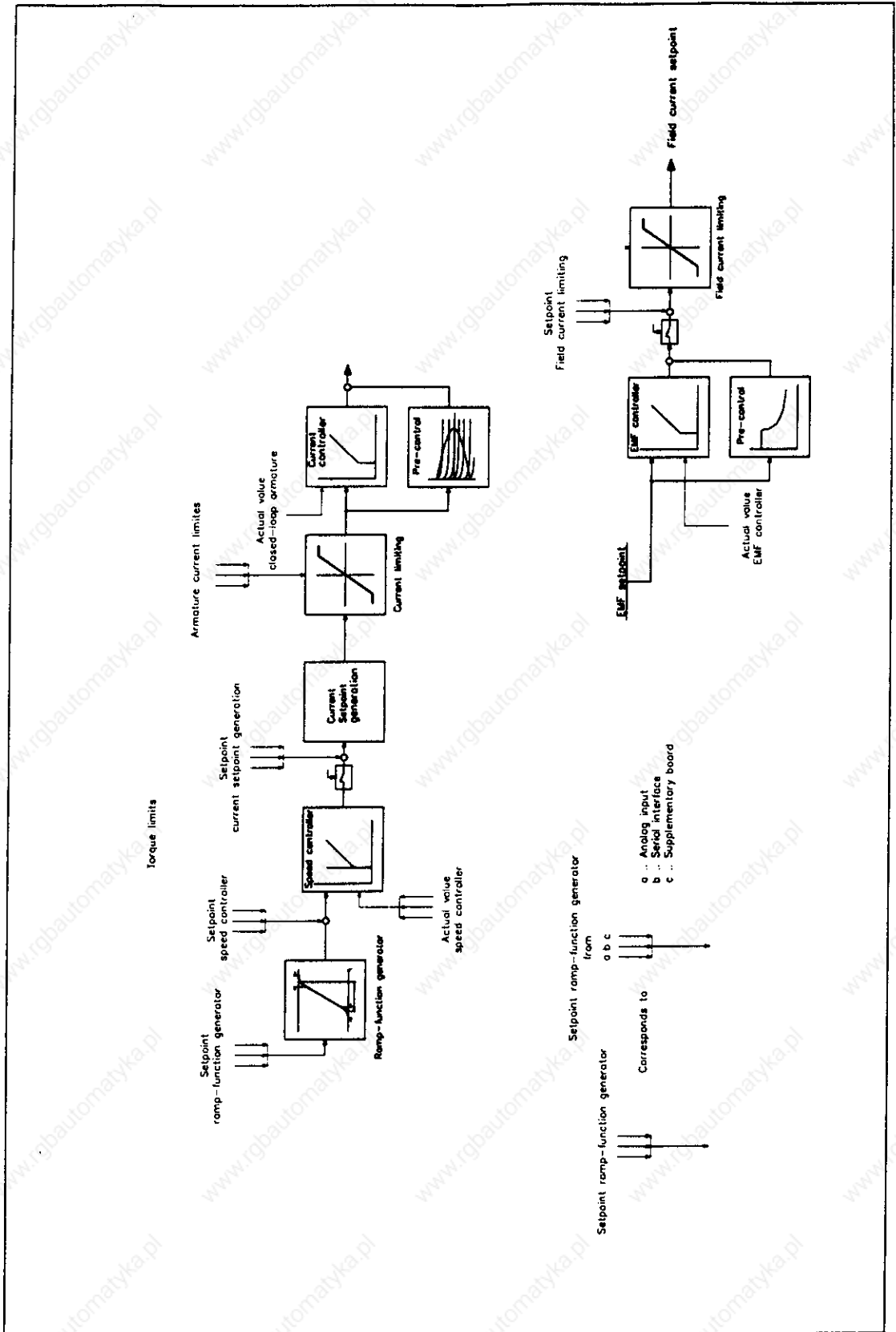

Sheet 2 Analog inputs

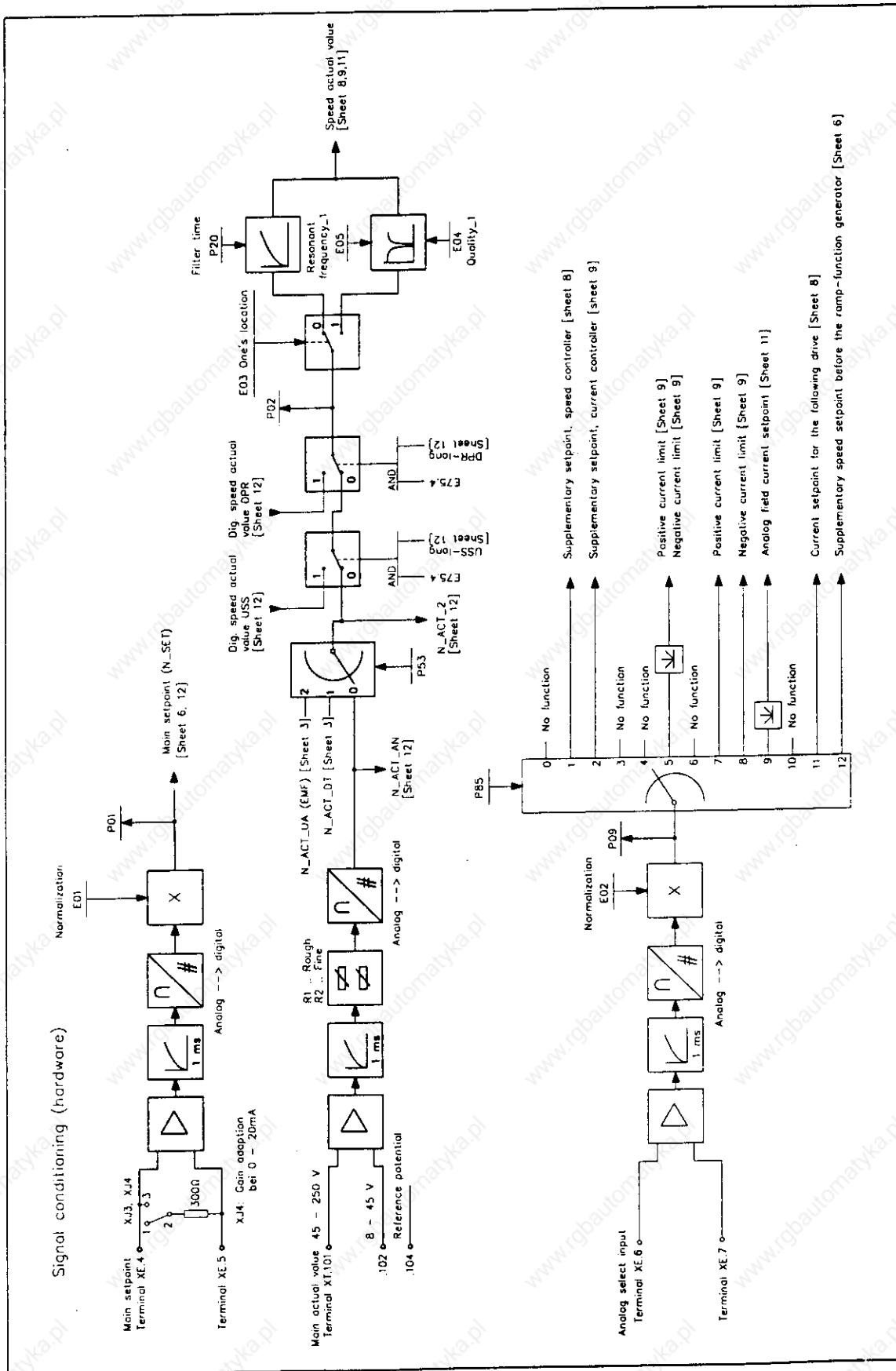

Sheet 3 Pulse encoder, internal detections

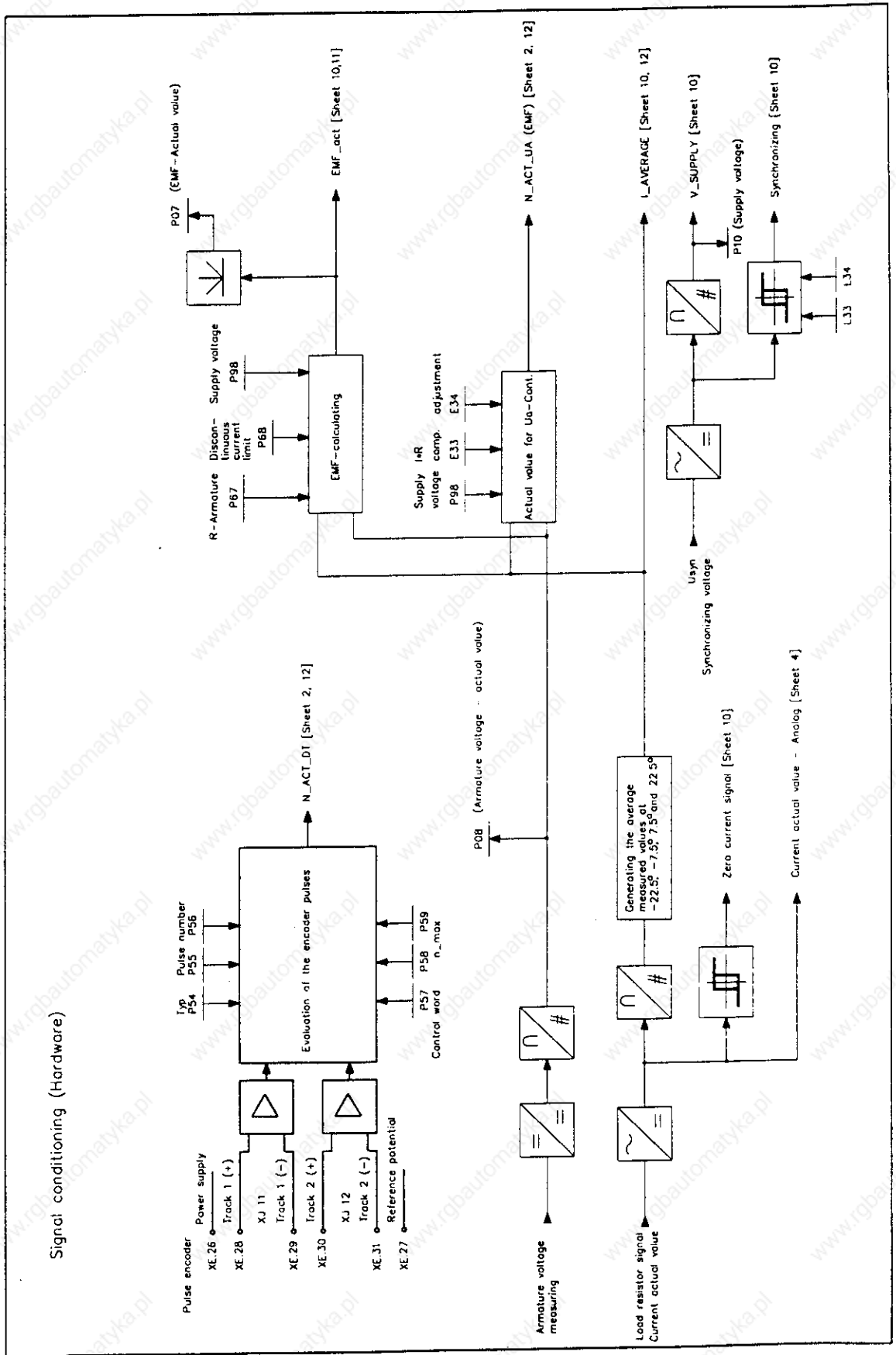

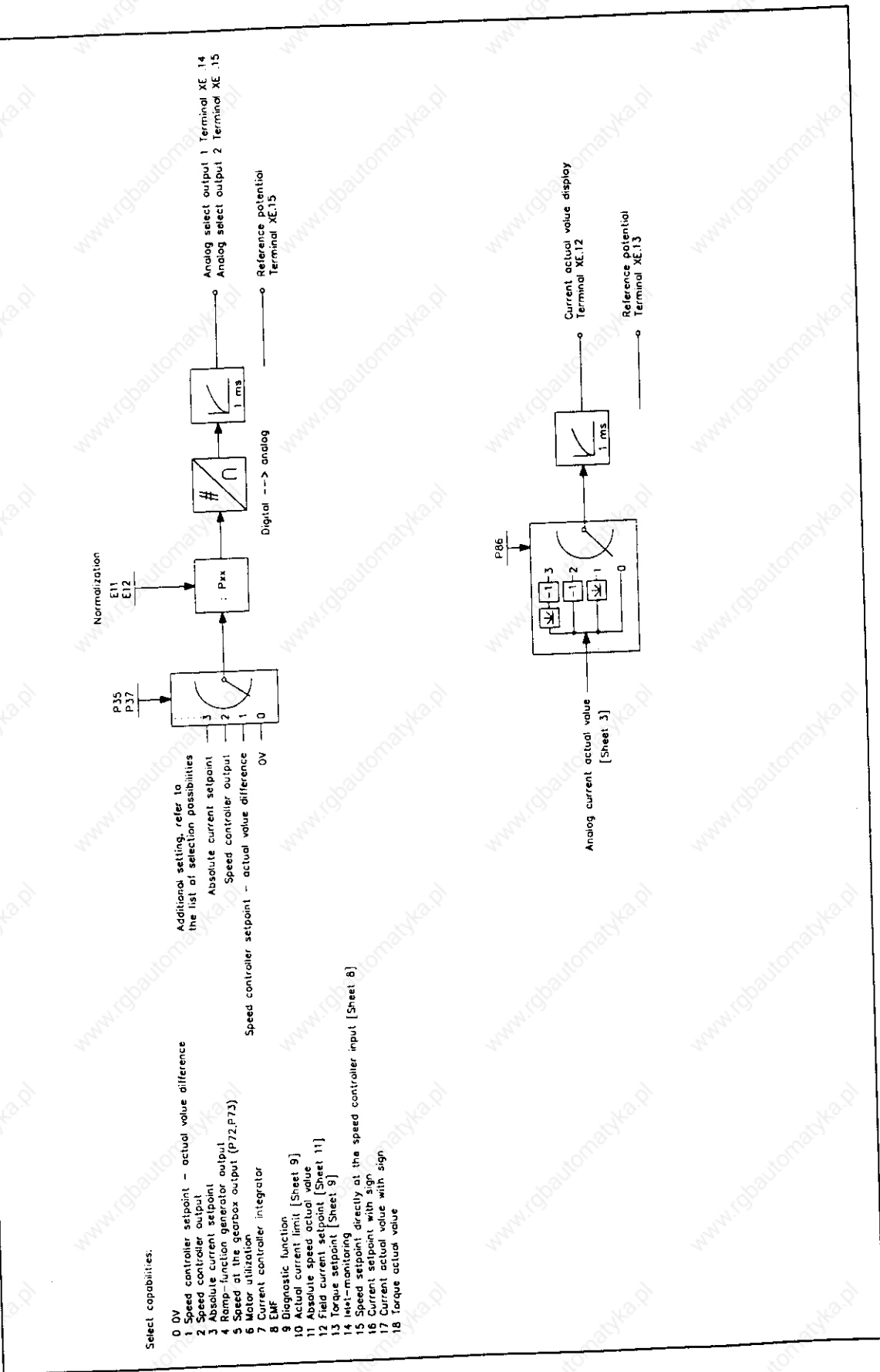

Sheet 5 Binary select inputs Binary select outputs

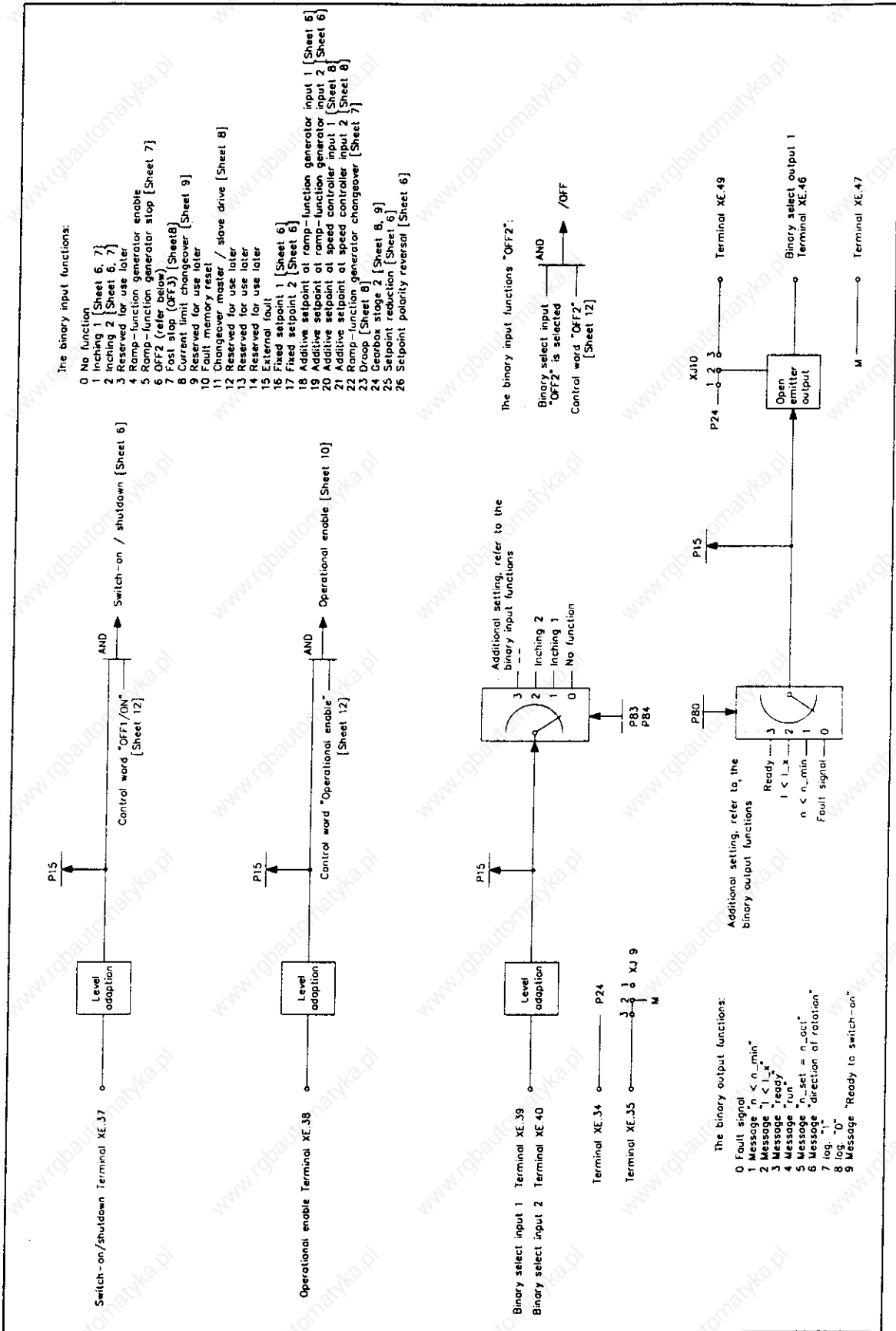

The binary input functions:

- 0 No function
- 1 Inching 1 [Sheet 6, 7]
- 2 Inching 2 [Sheet 6, 7]
- 3 Reserved for use later
- 4 Ramp-function generator enable
- 5 Ramp-function generator stop [Sheet 7]
- 6 OFF2 (see below)
- 7 Fast stop (OFF3) [Sheet 8]
- 8 Current limit changeover [Sheet 9]
- 9 Reserved for use later
- 10 Fault memory reset
- 11 Changeover master / slave drive [Sheet 8]
- 12 Reserved for use later
- 13 Reserved for use later
- 14 Reserved for use later
- 15 External fault
- 16 Fixed setpoint 1 [Sheet 6]
- 17 Fixed setpoint 2 [Sheet 6]
- 18 Additive setpoint at ramp-function generator input 1 [Sheet 6]
- 19 Additive setpoint at ramp-function generator input 2 [Sheet 6]
- 20 Additive setpoint at speed controller input 1 [Sheet 8]
- 21 Additive setpoint at speed controller input 2 [Sheet 8]
- 22 Ramp-function generator changeover [Sheet 7]
- 23 Droop [Sheet 8]
- 24 Gearbox stage 2 [Sheet 8, 9]
- 25 Setpoint reduction [Sheet 6]
- 26 Setpoint polarity reversal [Sheet 6]

The binary input functions "OFF2":



Additional setting, refer to the binary input functions

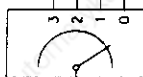

Additional setting, refer to the binary output functions

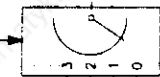

The binary output functions:

- 0 Fault signal
- 1 Message "n < n_min"
- 2 Message "l < l_min"
- 3 Message "ready"
- 4 Message "run"
- 5 Message "n set = n_act"
- 6 Message "direction of rotation"
- 7 log "1"
- 8 log "0"
- 9 Message "Ready to switch-on"

Sheet 6 Setpoint selection

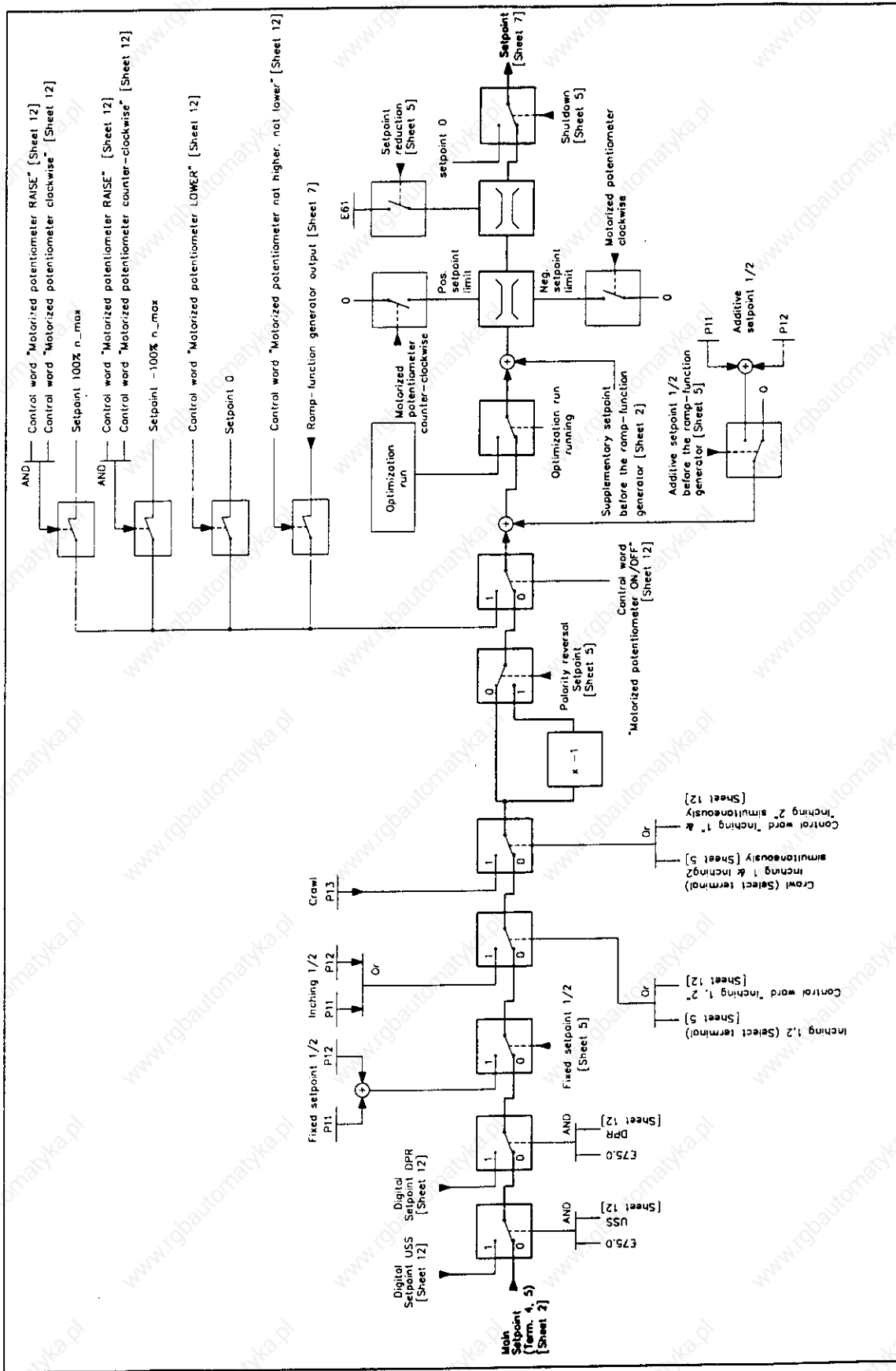

Sheet 7 Ramp-function generator

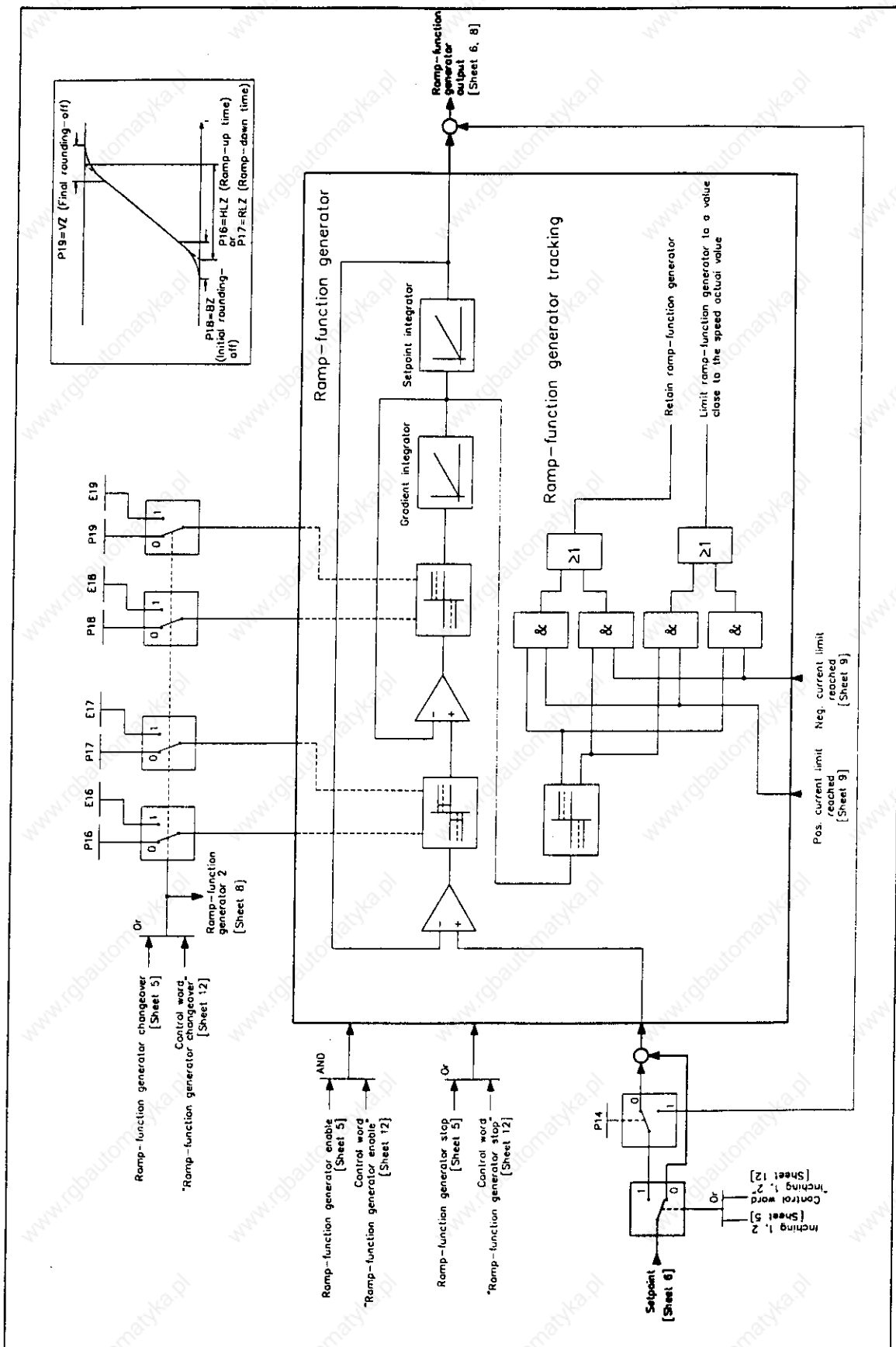

Sheet 8 Speed controller

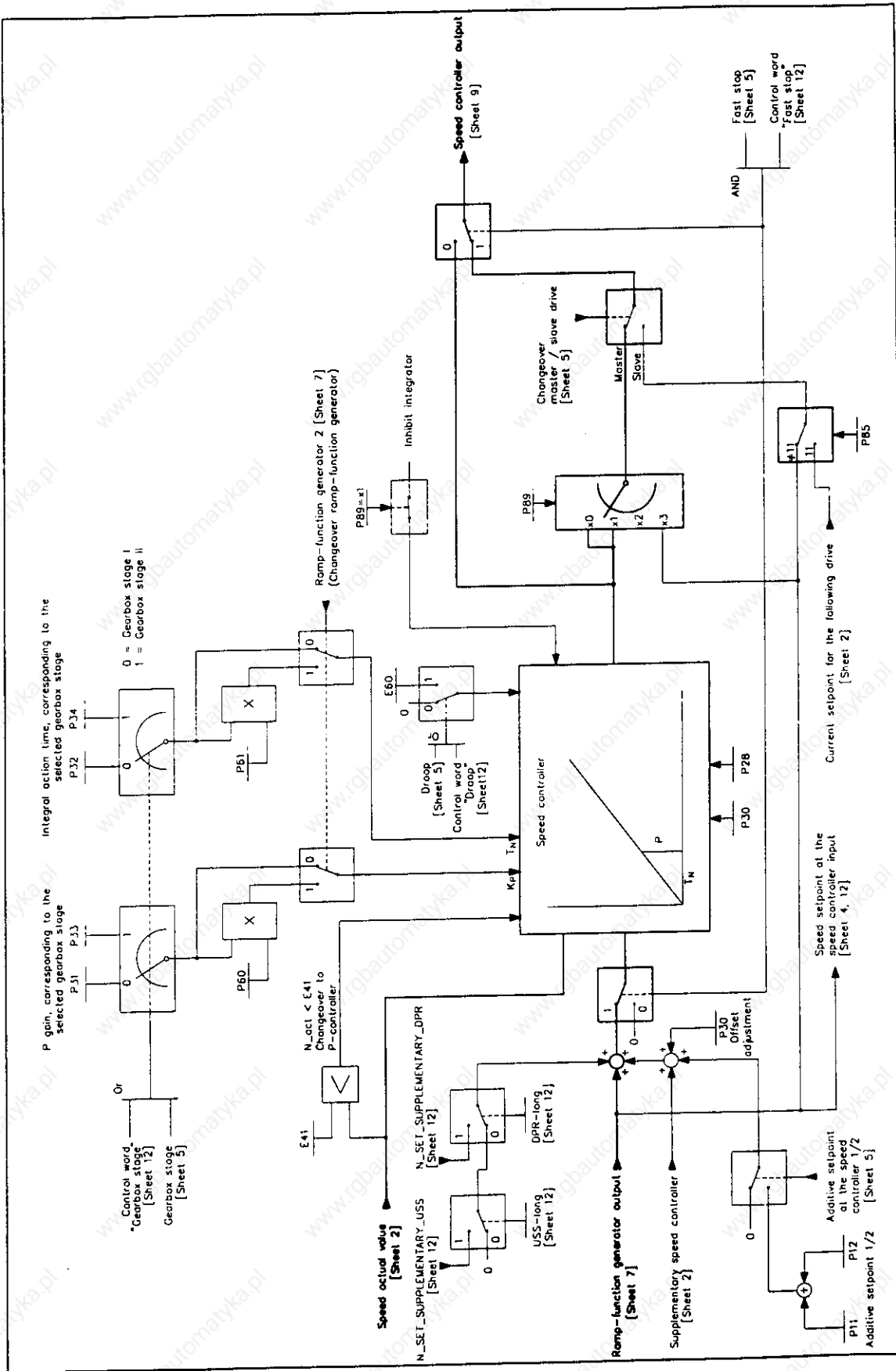

Sheet 9 Current limiting

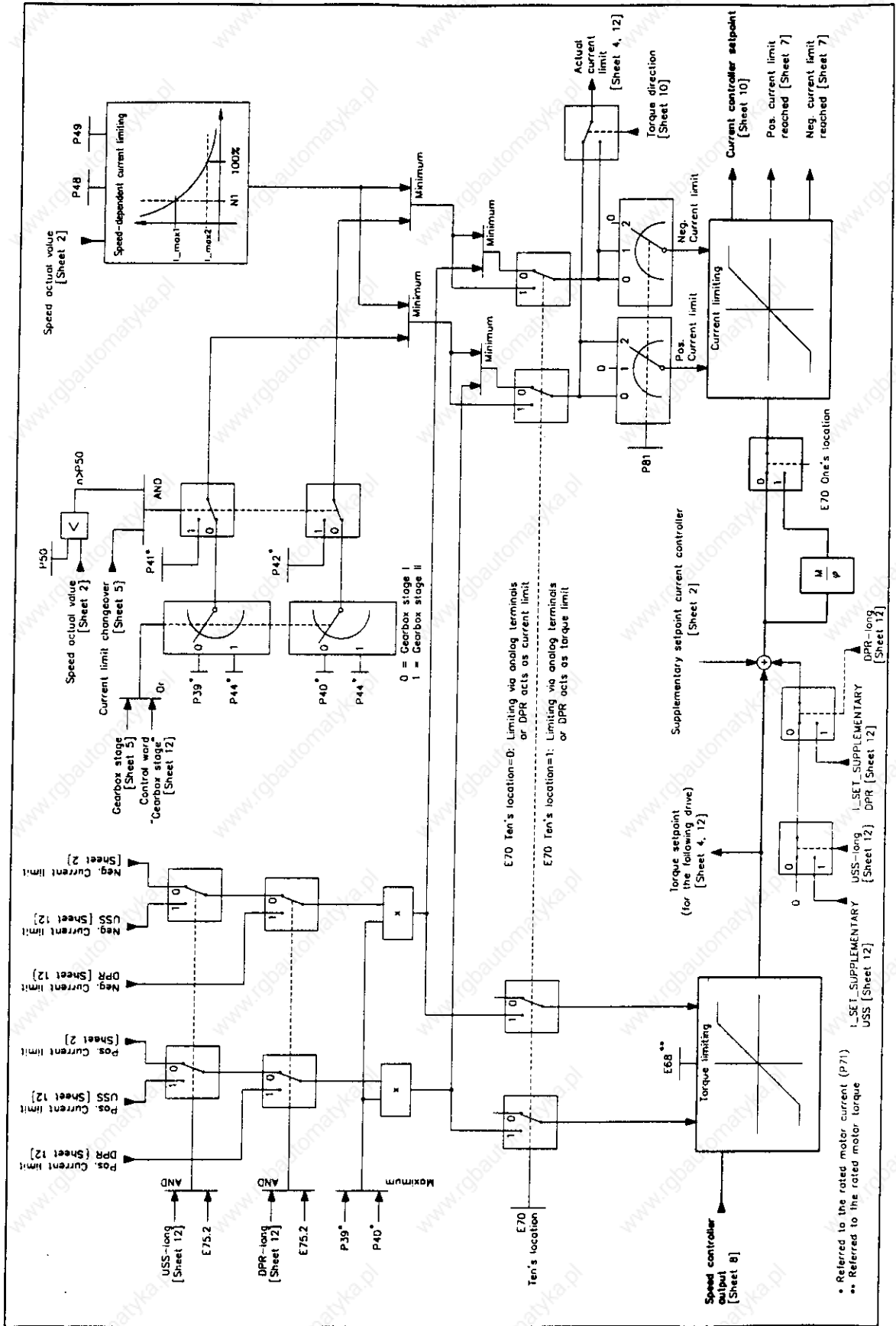

Sheet 10 Current controller

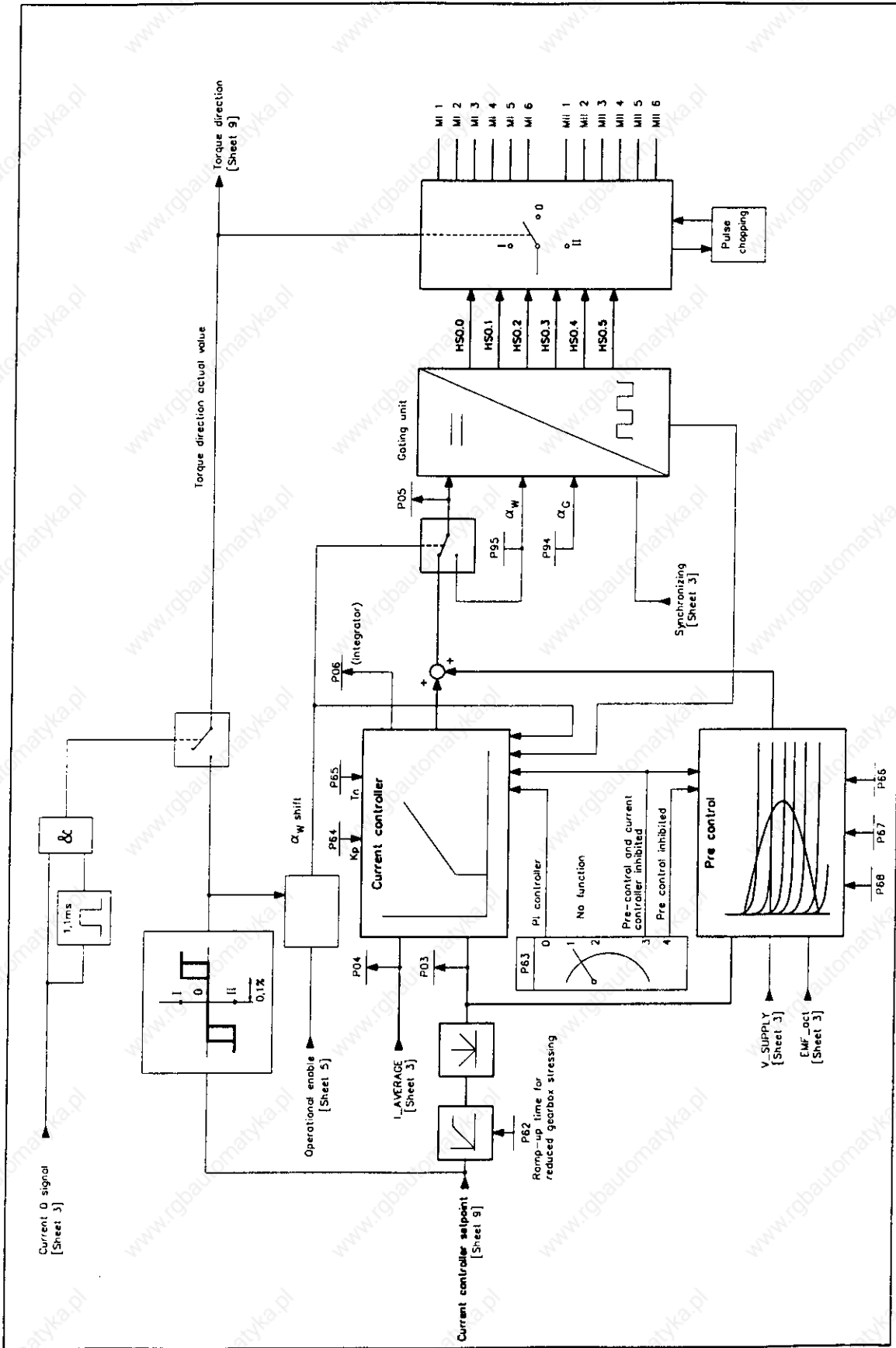

Sheet 11 Field control

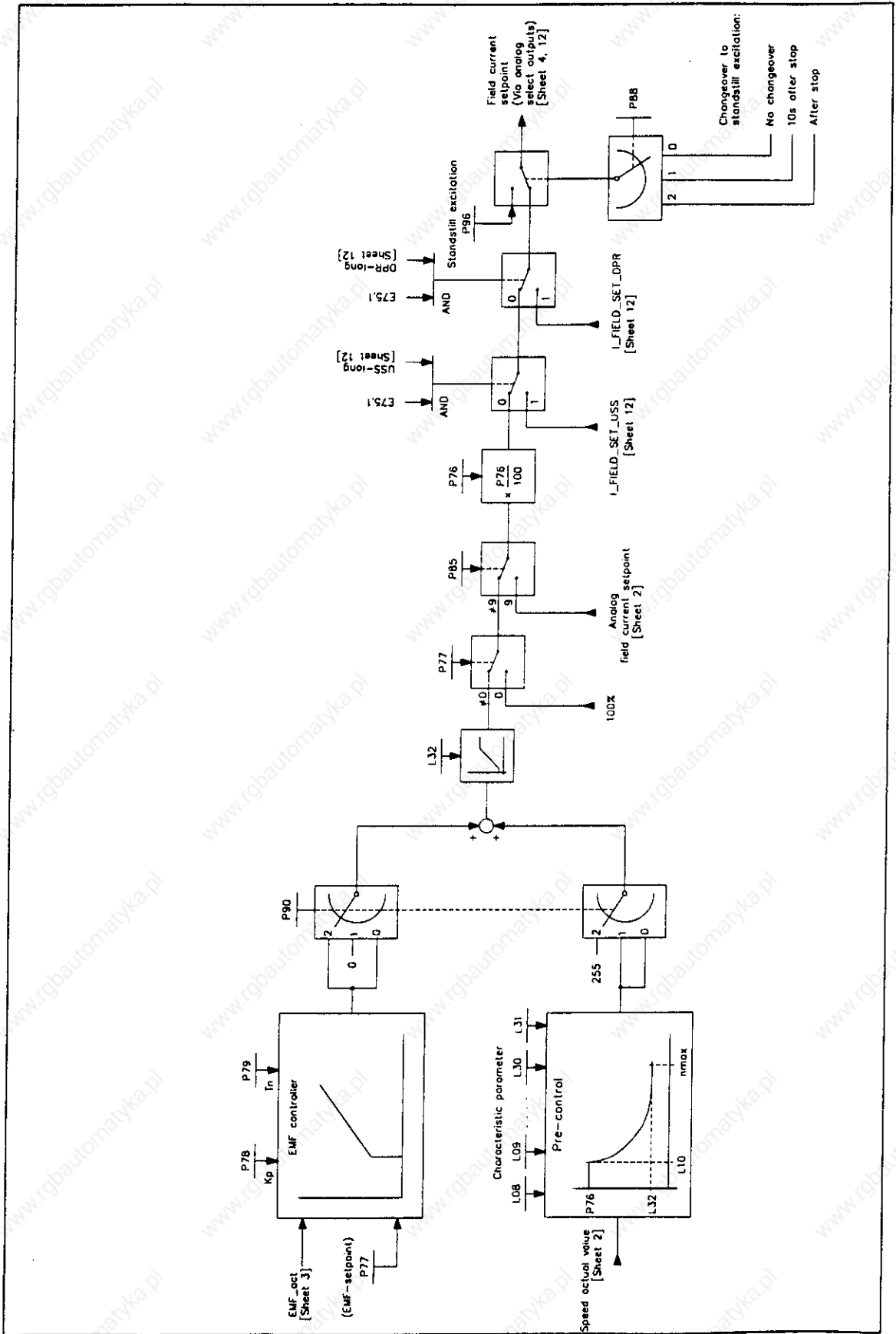

Sheet 12 Digital interfaces, process data PZD, USS (X501)
DPR (supplementary boards via X100)

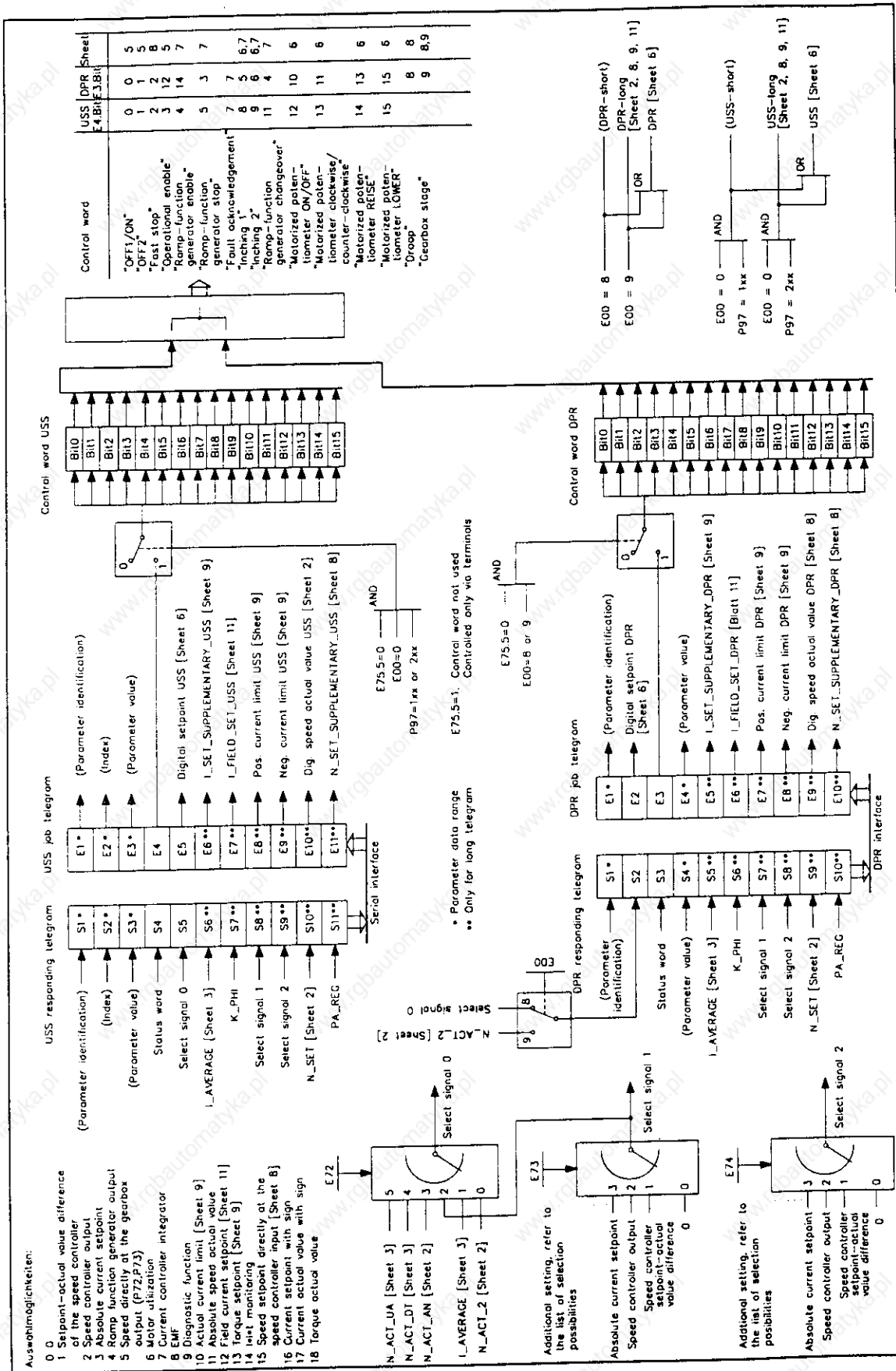

10.2 Binary input functions

The binary input functions can be switched to terminal 39 with parameter P83 and to terminal 40 with parameter P84.

0	No function
1	Inching 1
2	Inching 2
3	Reserved for use later
4	Ramp-function generator enable
5	Ramp-function generator stop
6	OFF 2 (disconnect voltage)
7	Fast stop (OFF3)
8	Current limit changeover
9	Reserved for use later
10	Fault memory reset
11	Changeover, master/slave drive
12	Reserved for use later
13	Reserved for use later
14	Reserved for use later
15	External fault
16	Fixed setpoint 1
17	Fixed setpoint 2
18	Additive setpoint at ramp-function generator input 1
19	Additive setpoint at ramp-function generator input 2
20	Additive setpoint at speed controller input 1
21	Additive setpoint at speed controller input 2
22	Ramp-function generator changeover
23	Droop
24	Gearbox stage 2
25	Setpoint reduction
26	Inverse setpoint polarity (from SW4.0)

Example: P83 = 7: The select function - fast stop - is effective at the terminal

10.2.1 Inching 1, crawl

10.2.2 Inching 2, crawl

Each of the digital select inputs (terminals 39 and 40) can be parameterized as "inching". The associated inching setpoint is deposited in a parameter (P11 for inching 1, P12 for inching 2).

The "inching" function is only possible with terminal 37 open-circuit (ON/STOP), and with terminal 38 energized (controller enable).

If a terminal, parameterized as "inching" is energized, the line contactor is switched-in via relay K3, and the inching setpoint injected, either via the ramp-function generator, or bypassing the ramp-function generator.

Parameter P14 can be used, for both terminals, to select whether the ramp-function generator is bypassed or not.

P14 = 0 Inching setpoint via the ramp-function generator.

P14 = 1 Inching setpoints are injected directly at the speed controller input, bypassing the ramp-function generator.

If terminals, parameterized as "inching" are opened, the controller is inhibited after $n < n_{\min}$ has been reached, and the line contactor is switched-out after 10 s (stop condition).

If both select terminals are selected as inching 1, or both select terminals as inching 2, and simultaneously energized, inching setpoint 0 is injected.

Crawl

If the digital select inputs (terminals 39 and 40) are parameterized as "inching 1 and 2", the "crawl" function is executed when terminals 39 and 40 are activated.

The "crawl" function is possible with terminal 37 (ON/STOP) in the open as well as in the closed condition. Terminal 38 (controller enable) must be activated.

Terminal 37 open (L signal)

The line contactor is switched-in via relay K3 when terminals 39 and 40 are simultaneously energized (H signal). The drive accelerates to the crawl setpoint (P13) along the ramp-function generator ramp.

The drive decelerates to zero speed along the ramp-function generator ramp when an L signal is applied to terminals 39 and 40.

The controller is inhibited for $n < n_{\min}$ (P21), and the line contactor (relay K3) is switched-out for $I = 0$.

Terminal 37 energized (H signal), the drive runs with the main setpoint.

When terminals 39 and 40 are simultaneously energized (H signal), the drive decelerates from the operating speed to the crawl speed (P13) via the ramp-function generator ramp.

The drive accelerates from the crawl speed to the operating speed via the ramp-function generator ramp (main setpoint) when an L signal is applied to terminals 39 and 40.

10.2.3 Reserved for use later

10.2.4 Ramp-function generator enable

If a terminal is parameterized as "enable ramp-function generator", the ramp-function generator is enabled when the terminal is energized.

If the terminal, parameterized as "enable ramp-function generator" is opened, the ramp-function generator is inhibited and its output is at 0.

This dominates over ramp-function generator stop.

10.2.5 Ramp-function generator stop

If a terminal is parameterized as "ramp-function generator stop", when the terminal is energized, ramp-up and ramp-down are interrupted, and the ramp-function generator output is held at the instantaneous value.

When the terminal is de-energized or opened, the ramp-function generator output is enabled, and the ramp-function generator runs with the selected ramp-up or ramp-down time.

10.2.6 OFF (OFF 2, disconnect voltage)

If a terminal is parameterized as "OFF", when an L signal is connected to the terminal (terminal open-circuit) the controller is inhibited, the firing angle is shifted to α_w and the line contactor switched-out after $I = 0$ (via relay K3).

The motor coasts down unbraked.

If both select terminals (39 and 40) are parameterized as "OFF", to switch-on, an H signal must be connected to both terminals. "OFF" can be forced by opening (L signal) at one or both terminals.

10.2.7 Fast stop (OFF 3)

If a terminal is parameterized as "fast stop", when an L signal is connected (terminal open-circuit), 0 setpoint is injected, bypassing the ramp-function generator. The drive decelerates to 0 along the current limit. The controller is inhibited at $n < n_{\min}$ (P21), and for $I = 0$, the line contactor is switched-out (via relay K3).

The "fast stop" command is internally stored. Thus, the "fast stop" function can be initiated by briefly applying (> 10 ms) an L signal at the terminal. The stored signal is cancelled by applying an L signal to terminal 37.

If both select terminals (39 and 40) are parameterized as "fast stop", an H signal must be applied to both terminals to switch-on the drive. "Fast stop" can be input by opening (L signal) one or both terminals.

NOTE

A parameterized "supplementary setpoint, current controller" remains effective at fast stop, which can result in a reduction of the braking current, dependent on its polarity.

10.2.8 Current limit changeover

If a terminal is parameterized as "current limit changeover", when the terminal is energized, the current limit, set at parameters P41 and P42, becomes effective, if the speed actual value $> n_{\text{changeover}}$ (P50). Parameter P39 or P40 remains the effective current limit for lower speed actual values than are set in P50, or when the terminal is open.
Parameter P44 is the valid current limit when gearbox stage 2 is selected.

10.2.9 Reserved for later use

10.2.10 Fault memory reset

If a terminal is parameterized as "reset fault memory", any fault is acknowledged by applying a low-high transition at the terminal (corresponds to depressing the MODE button).

10.2.11 Changeover, master/slave drive

If a terminal is parameterized as "changeover, master/slave drive", when the terminal is energized (H signal), the converter is changed-over to closed-loop current control, and can then be operated as slave drive.

If both terminals (39 and 40) are parameterized as "changeover, master/slave drive", then these are logically OR'd (i.e. if one of the terminals is energized, a changeover is made to the slave drive).

Master drive

The master drive is operated in the closed-loop speed control mode: $P89 = x0$, the current setpoint for the master drive is extracted via one of the analog select outputs, terminal 14 or 16:

$P35$ or $P37 = 16$, normalization: For SW1.0 $P36$ or $P38 = 1.0$, from SW4.0, $E11$ or $E12 = 1.0$.

Signal level: Rated converter current (torque direction I) corresponds to $+8.0V$ at terminal 14 or 16 with respect to terminal 15.

Slave drive

The slave drive can be changed-over between closed-loop speed control and closed-loop current control using the binary input function 11 (also during operation):

P83 = 11	Terminal 39	LOW . . . closed-loop speed control HIGH . . . closed-loop current control (slave drive)
P84 = 11	Terminal 40	LOW . . . closed-loop speed control HIGH . . . closed-loop current control (slave drive)

The speed setpoint is input via terminals 4 and 5 (ramp-function generator effective).

The current setpoint is injected via terminals 6 and 7 (analog select input) (ramp-function generator not effective): P85 = 11, normalization E02 = 80.

Signal level: + 8.0 V at terminal 6 with respect to terminal 7 corresponds to the rated converter current (torque direction I).

The speed controller output is set to 0 when a slave drive is selected. At the transition from current control (slave drive) to speed control, the drive operates at the current limit, at the speed corresponding to the speed setpoint available (ramp-function generator not effective). When the stop signal is input at the master and slave drive (terminal 37 LOW), controller inhibit is only issued when $n < n_{min}$, for both the speed control as well as current control modes, so that the slave drive is also shutdown in a controlled fashion. When "fast stop" is input (binary input function 7 parameterized at a binary select input) simultaneously for both the master and slave drives, the drive is braked to zero speed in current limiting, both in the speed- and current control modes, and the controller inhibit is issued only when $n < n_{min}$, so that both drives can be braked as quickly as possible.

10.2.12 Reserved for use later

10.2.13 Reserved for use later

10.2.14 Reserved for use later

10.2.15 External faults

If a terminal is parameterized as "external fault", fault message F14 (external fault) is displayed, if a low signal is present for longer than 1 s. The fault message is then only effective for operating conditions < o6.

When a fault message occurs, the drive coasts down.

The delay time is 2 s in operating status o4.

10.2.16 Fixed setpoint 1**10.2.17 Fixed setpoint 2**

If a terminal is parameterized as "fixed setpoint 1 or 2", when the terminal is energized (H signal) the main setpoint is disconnected and the fixed setpoint injected (P11 = fixed setpoint 1, P12 = fixed setpoint 2).

The setpoint injection function is effective when terminal 37 is energized (ON/STOP) and terminal 38 (controller enable).

If both select terminals (39 and 40) are parameterized as "fixed setpoint", when both terminals are simultaneously energized, the appropriate setpoints are added (internally limited to 105% n_{max}).

If all terminals parameterized as setpoint injection, are opened, the main setpoint is used.

The actual ramp-function generator is effective with the "fixed setpoint" function (no control from P14).

10.2.18 Additive setpoint 1 at the ramp-function generator input**10.2.19 Additive setpoint 2 at the ramp-function generator input**

If a terminal is parameterized as "additive setpoint at the ramp-function generator input", when the terminal is energized (H signal), the setpoint, set at P11 (for "additive setpoint 1 at the ramp-function generator input") or P12 (for "additive setpoint 2 at the ramp-function generator input") is added to the actual setpoint in front of the ramp-function generator.

The function is effective when terminal 37 (ON/STOP) and terminal 38 (controller enable) are energized.

If both select terminals (39 and 40) are parameterized as "additive setpoint at the ramp-function generator input", when both terminals are energized, both setpoints are added (internal limit to 105% n_{max}).

If all of the terminals parameterized as additive setpoint injection are opened, the supplementary setpoint is disconnected.

10.2.20 Additive setpoint 1 at the speed controller input**10.2.21 Additive setpoint 2 at the speed controller input**

If a terminal is parameterized as "additive setpoint at the speed controller input", when the terminal is energized (H signal), the setpoint, set at P11 (for "additive setpoint 1 at the speed controller input") or P12 (for "additive setpoint 2 at the speed controller input") is added to the actual setpoint at the speed controller input (after the ramp-function generator).

The function is effective when terminal 37 (ON/STOP) and terminal 38 (controller enable) are energized.

If both select terminals (39 and 40) are parameterized as "additive setpoint at the speed controller input", both setpoints are added (internal limit to 105% n_{max}) when both terminals are energized.

If all of the terminals parameterized as additive setpoint injection are opened, the supplementary setpoint is disconnected.

10.2.22 Ramp-function generator changeover

If a terminal is parameterized as "ramp-function generator changeover", when the terminal is energized (H signal), a 2nd parameter set is selected for the ramp-function generator.

Parameter E16: Ramp-up time 2
 Parameter E17: Ramp-down time 2
 Parameter E18: Initial rounding-off 2
 Parameter E19: Final rounding-off 2

If the terminal is not energized, then the ramp-function generator times from P16 to P19 are valid.

If the terminal is energized, the speed controller parameters can be additionally evaluated with parameters P60 and P61.

The actual proportional component of the speed controller is multiplied by the contents of parameter P60, and the integral action time with the contents of P61. The actual values for the proportional component and integral action time are dependent on the selected gear stage P60 and P61 should be set to 1 for standard operation.

10.2.23 Droop

If a terminal is parameterized as "droop", when the terminal is energized (H signal), a feedback, which can be parameterized, is switched in parallel with the speed controller (PI controller) (E60: Max. 10% of the setpoint, 0.1% steps) (also refer to the analog equivalent circuit diagram Section 9.2 "Parameter description" E60).

10% droop means that the speed actual value deviates by 10% of the maximum speed from the setpoint when the drive is loaded with rated converter current. The function is used for current distribution between two or several drives.

Droop is no longer effective when the terminal is de-energized.

If none of the terminals are parameterized as "droop", the additional feedback is always effective. The droop function can be disabled using the parameter setting E60 = 0.

If two terminals are parameterized as "droop", both terminals must be energized so that "droop" is effective.

10.2.24 Gearbox stage 2

If a terminal is parameterized as "gearbox stage 2", when the terminal is energized (H signal), a dedicated parameter set is selected:

Parameter P33: Proportional component, speed controller
 Parameter P34: Integral action time, speed controller
 Parameter P44: Current limit (the same value for torque directions M I and M II)
 Parameter P24: n_x (speed threshold)

10.2.25 Setpoint reduction

If a terminal is parameterized as "setpoint reduction", when the terminal is energized (H signal), the setpoint at the ramp-function generator input is limited to the value set at parameter E61 (% of n_{max} , max. speed limiting).

10.2.26 Invert setpoint polarity (from SW 4.0)

If a terminal is parameterized as "invert polarity setpoint", when the terminal is energized (H signal), the setpoint polarity is inverted, if it comes from one of the following sources:

- main setpoint terminal (terminals 4 and 5)
- digital setpoint from the dual port RAM, or from the serial interface (GSS-T1 with USS protocol)
- fixed setpoint (refer to Sections 10.2.16 and 10.2.17)
- inching, crawl, (refer to Section 10.2.1 and 10.2.2)
(also refer to Section 10.1, Sheet 6)

10.3 Setting the current limits

P39 = B + for M I

P40 = B - for M II

Ratio = required limit current / $I_{\text{motor rated}}$ in % (max. 300% possible)

A second parameter set can be selected (P41 and P42) for current limit changeover, refer to Section 10.2.8).

NOTE

The converter output current is automatically limited to the rated converter current according to the rating plate.

10.4 Speed-dependent current limiting

P48 = Intervention point as % of n_{max}

P49 = Current limit as % of I_{motor} at max. speed

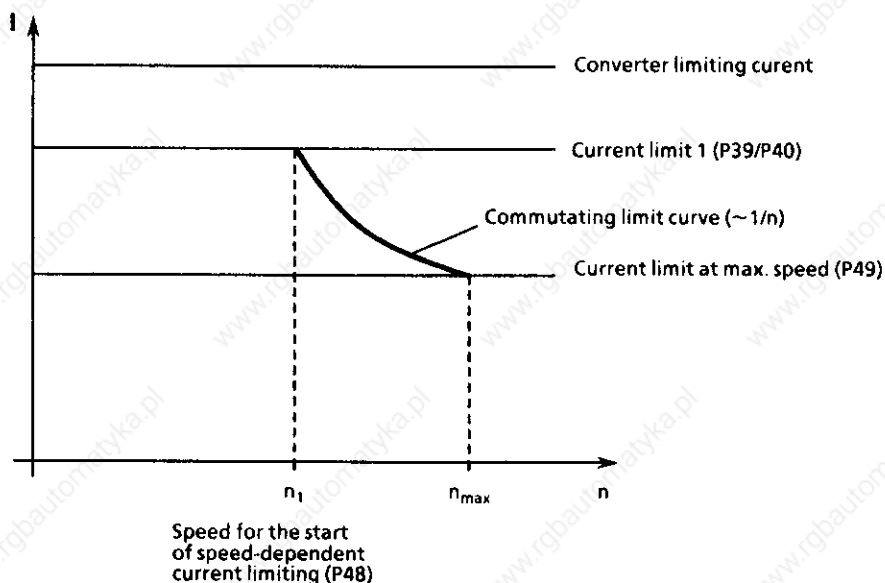

10.5 Thermal overload protection of the DC motor (I²t monitoring)

I²t monitoring is parameterized using parameters P70 and P71. The motor is protected from inadmissible loads using the appropriate adaption (complete motor protection is not provided).

Adaption

P70: A time constant T_{motor} must be entered in minutes into parameter P70, with which the I²t monitoring should operate.

P71: The ratio of the rated motor current to the limiting converter current, as a %, should be entered into parameter P71, as specified on the rating plates.

Alarm characteristic / shutdown characteristic

If the motor is continuously loaded, for example with 125% of the rated motor current, an alarm signal is issued (only when supplementary boards are used) after a time constant has expired (P70). If the load is not reduced, the drive is switched to a torque-free condition when the shutdown characteristic is reached, and fault message F13 starts to flash.

Alarm/shutdown times for other load conditions can be taken from the diagram.

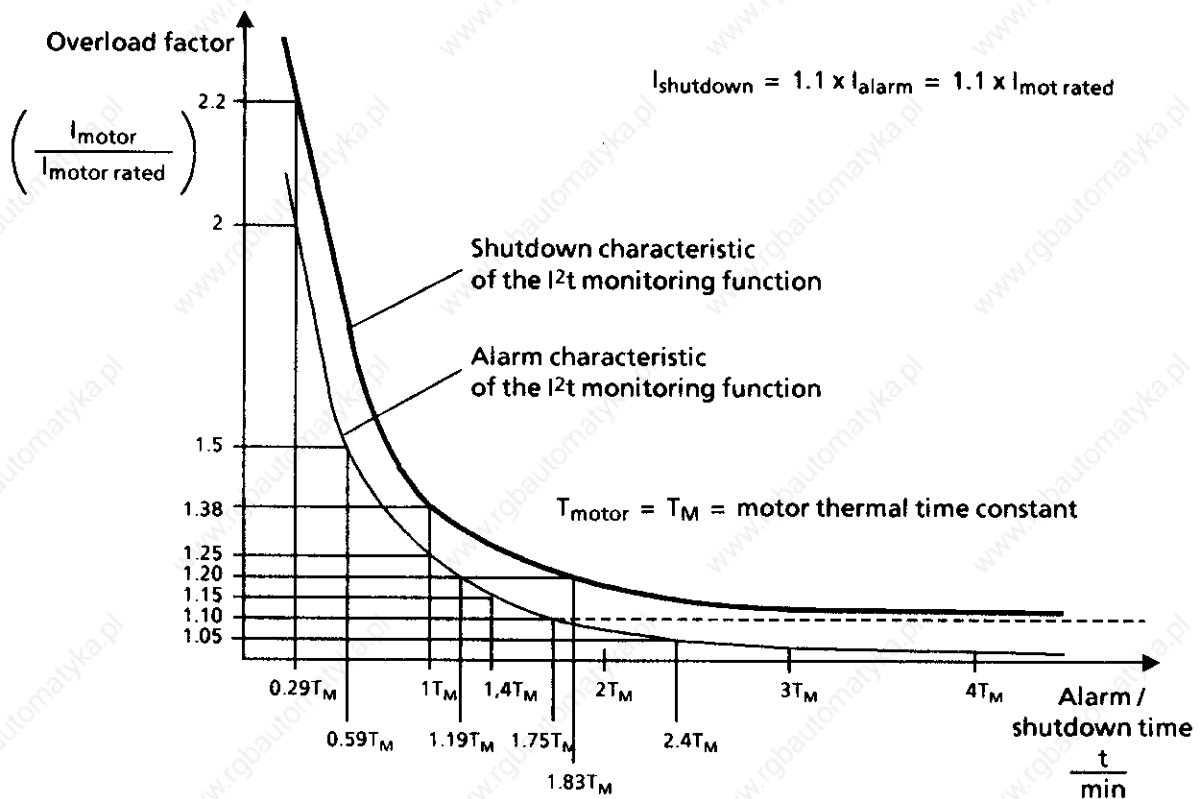

NOTE

- When the electronics power supply fails, the calculated motor pre-loading information is lost. When the supply is re-established, it is assumed that the motor was not previously loaded!
- The I²t monitoring only represents a rough approximation of the motor thermal image (this does not represent complete motor protection).
- If a zero is set in P70 (T_{motor}), the I²t monitoring function is disabled.

Determining the thermal equivalent time constant

It should be noted that the thermal equivalent time constant is a function of the max. overcurrent.

Thermal equivalent time constants for 1G . 5/1H . 5 DC motors, according to Catalog DA12.

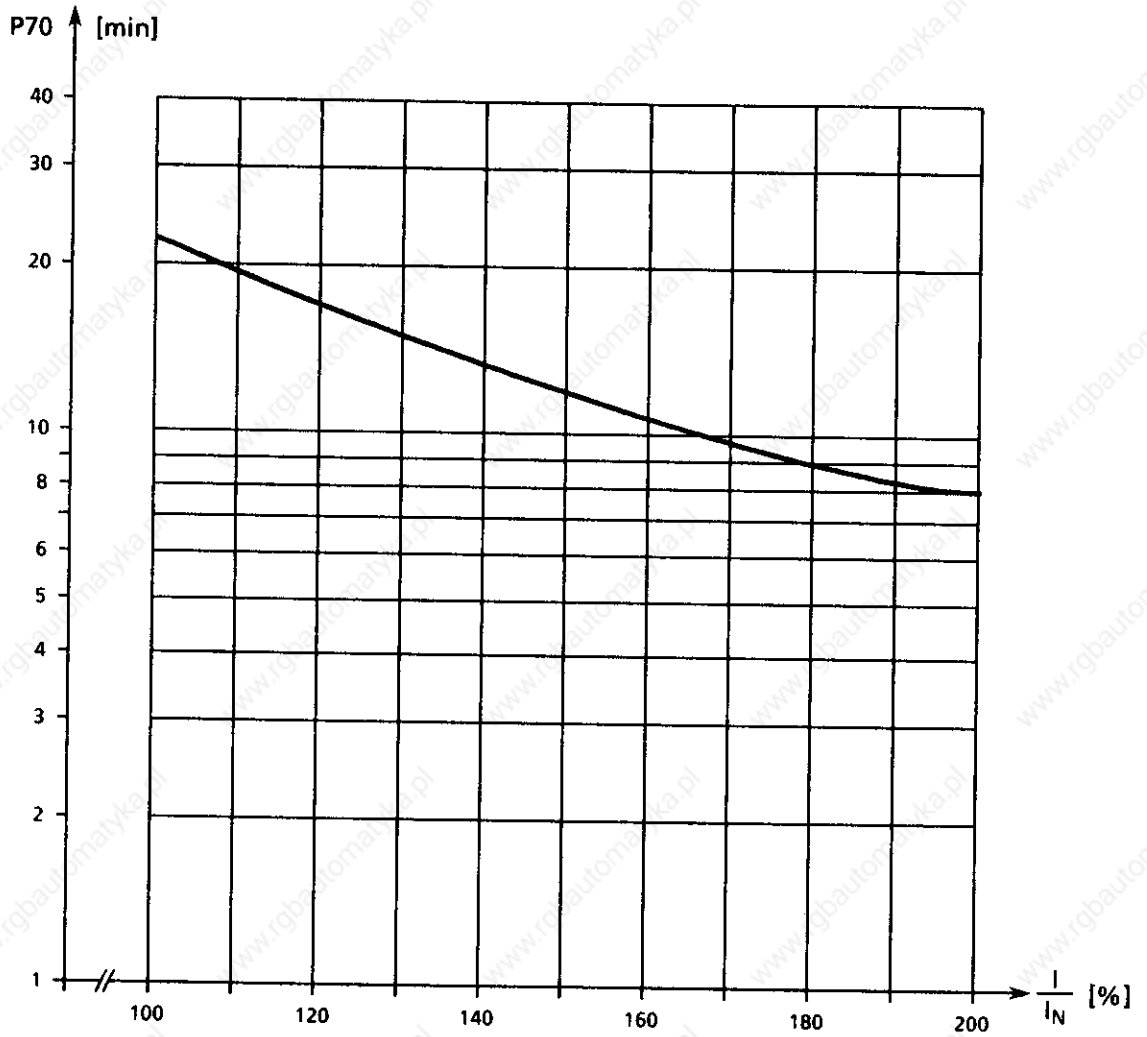

NOTE

When other motors are used, please observe the manufacturers information.

10.6 Standstill monitoring via the binary select output (terminal 46)

P80 = 1 Terminal 46 as $n < n_{\min}$ signal

P21 = Set n_{\min} threshold

Example: For P21 = 1% terminal 46 is logical "1", if the speed falls below 1% of the maximum speed.

10.7 Reduced gearbox stressing

P62 Setting the current setpoint integrator (0 - 100ms)

The reduced gearbox stressing is effective at torque direction change. The setpoint is fed to the current controller via a ramp-function generator (P62)

10.8 Anti-stall protection

The shutdown time can be set using P43: 0 to 60 s

The monitoring responds, as a function of the following conditions:

- The speed actual value is less than 0.4% of n_{\max}
- The current setpoint has reached the current limit
- Closed-loop speed control operation
- The converter issues message F16 after the time, set in P43, has expired.

The fault message is suppressed for parameter P89 = x3 (closed-loop current control operation).

If the speed controller goes into saturation and the converter is controlled via the current limit (master-slave changeover), the monitoring function must be suppressed (refer to Section 10.13).

P43 = 0: F16 anti-stall protection suppressed.

10.9 Ramp-function generator

Set the ramp-function generator

P16 = T+ ... Ramp-up time 1 0 - 300s

P17 = T- ... Ramp-down time 1 0 - 300s

P18 = AR ... Initial rounding-off 1 0 - 10s

P19 = ER ... Final rounding-off 1 0 - 10s

Supplementary ramp-function generator functions via select terminals 39 or 40:

- Ramp-function generator changeover: Selecting a second ramp-function generator (E16 to E19).
- Ramp-function generator STOP: The ramp-function generator output is held at its actual value.
- Ramp-function generator enable: The ramp-function generator output is set to 0 when the ramp-function generator enable signal is missing; for 4-quadrant converters, this causes the drive to brake along the current limit.

- Prevents overshoot of the speed actual value after setpoint jumps at the ramp-function generator input as follows:

When the ramp-function generator runs, the speed controller integral action time is multiplied by a factor. This factor can be set via the tens position of parameter P89.

P89 = 0x ... factor 1 (i.e. function disabled)
 1x ... factor 1000

The adaption is only effective for active ramp-function generator (P16 <> 0, P17 <> 0)

The actually effective integral action time is internally limited to max. 100 s!

Additional ramp-function generator modes should be taken from the parameter description for parameter P14.

10.10 Closed-loop torque control

In the armature control range, i.e. the motor field is constant over the complete speed control range, the converter current is directly proportional to the motor torque.

However, it is also possible to operate the drives with closed-loop torque control, in field weakening. The speed controller output corresponds to the torque setpoint. This value is divided by the actual motor flux, and is fed to the current controller as setpoint.

Closed-loop torque control in the field-weakening mode is possible when an external, controlled field converter is used.

Selecting the mode for closed-loop torque control

- E70 = x0 ... Closed-loop current control
 x1 ... Closed-loop torque control (i.e. the speed controller output is divided by the actual motor magnetic flux)
 0x ... Analog limiting via analog select terminals 6 and 7 act as current limiting
 1x ... Analog limiting via analog select terminals 6 and 7 act as torque limiting

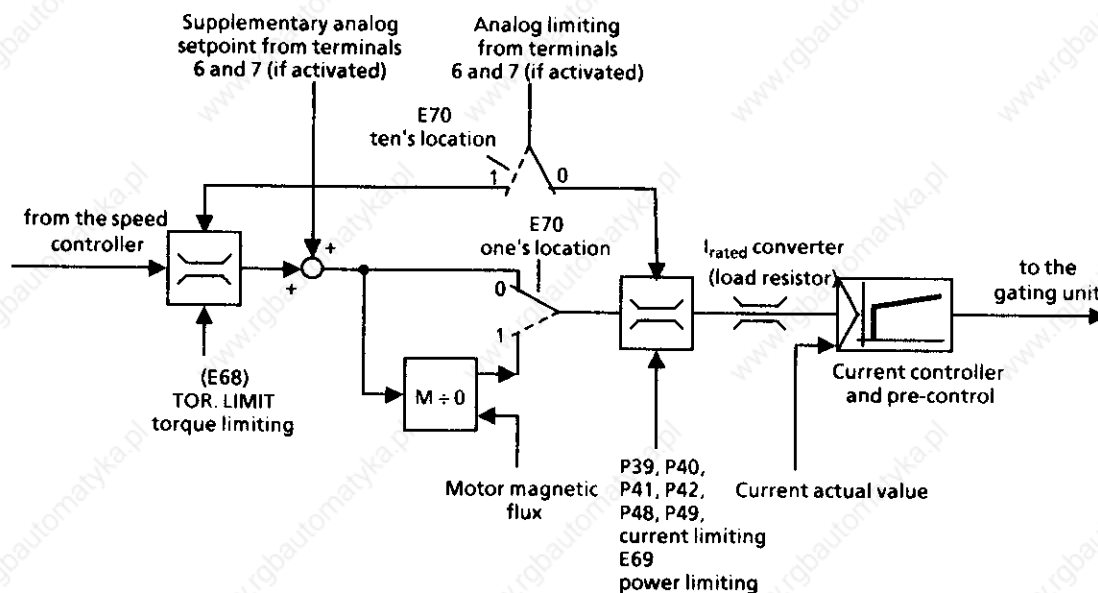

10.11 Changeover from closed-loop speed to current control operation

Changeover using parameter P89 (offline)

P89 = x0 The converter operates in the closed-loop speed control mode
The speed setpoint is fed from terminals 4 and 5 (main setpoint), via the ramp-function generator.
A second speed setpoint can be applied at terminals 6 and 7 (analog select input).
This can be either parameterized as follows:

P85 = 1 Ramp-function generator not effective

P85 = 12 Ramp-function generator effective

P89 = x3 The converter operates in the closed-loop current control mode.
The current setpoint is fed from terminals 4 and 5 (main setpoint), via the ramp-function generator. A second current setpoint can be applied at terminals 6 and 7 (analog select input). This can either be parameterized as:

P85 = 2 Supplementary setpoint for the current controller, this is injected after the torque limiting.

P85 = 12 Current setpoint, ramp-function generator active

The ramp-function generator can be disabled in the closed-loop current controlled mode, either with P16 to P19 = 0, or by parameterizing the master/slave drive P83 or P84 = 11 and terminal 39 or 40 with a high signal.

A changeover can be made between speed control and current control operation and vice versa while the drive is running using the binary input function 11 "changeover, master/slave drive", refer to Section 10.2.11.

10.12 Operation on weak supplies

e.g. High harmonic content
Fast frequency change
Low system fault level
Supply via diesel generator (island operation)
Significant commutation dips

The supply conditions listed above can mean that fault F03 or F11 occur sporadically.

The following settings can also be made:

- **Behavior on supplies with unstable frequency condition**

Frequency tracking speed can be set using

Parameter L33, one's position:

L33 = x0 . . . stiff supplies (standard setting)

x1 . . . weak supplies

x2 . . . weak supplies

x3 . . . weak supplies (higher number corresponds to faster tracking)

- **Tachometer cable interruption monitoring function**

The response threshold for fault message F11 can either be set using

Parameter L33, ten's location:

L33 = 0x ... response threshold = 60V x P98/400

1x ... response threshold = 120V x P98/400

2x ... response threshold = 180V x P98/400

3x ... response threshold = 240V x P98/400

The response threshold refers to the magnitude of the armature voltage.

When the converters are operated from a diesel generator supply, the setting L33 = 022 is recommended.

NOTE

- If the response threshold for the tachometer monitoring is increased, the converter only shutdowns at a higher speed if the tachometer actually fails.
- When increasing the frequency tracking speed, increased armature current ripple can occur.

- **Phase shift correction for the synchronizing filter**

For supplies with significant harmonics, fault messages can occur (F03, F11).

Parameter L34: – 199 to + 199 x 10 μ s, and additionally phase shift

Parameter L34 is set during optimization (select with P51 = 2).

Manual setting: P89 = 3 (closed-loop current controlled operation)
 Disconnect the field
 Enter current setpoint > 2% at terminals 4 and 5
 Read-out the contents of P07 (EMF)
 Change L34 until the contents P07 = 0

Parameter L33 is generally set, as the harmonic contents of the supply are often not constant.

10.13 Disabling monitoring functions/suppressing fault messages



WARNING

The monitoring functions integrated in the converter protect it and ensure system safety. If the monitoring functions are disabled, the converter might not respond or incorrectly respond to a fault condition. This can result in death, severe bodily injuries or material damage.



Equipment damage resulting from this is not covered by the warranty.

Only fully qualified personnel, who are totally knowledgeable about the safety instructions included in the Instruction Manual as well as in the installation operation and service of the equipment should work with this unit.

Every individual monitoring function which can be disabled is assigned a bit in a control register (parameter P91). The required bit pattern must be entered in hexadecimal form. The conversion table below can be used to define the hexadecimal number.

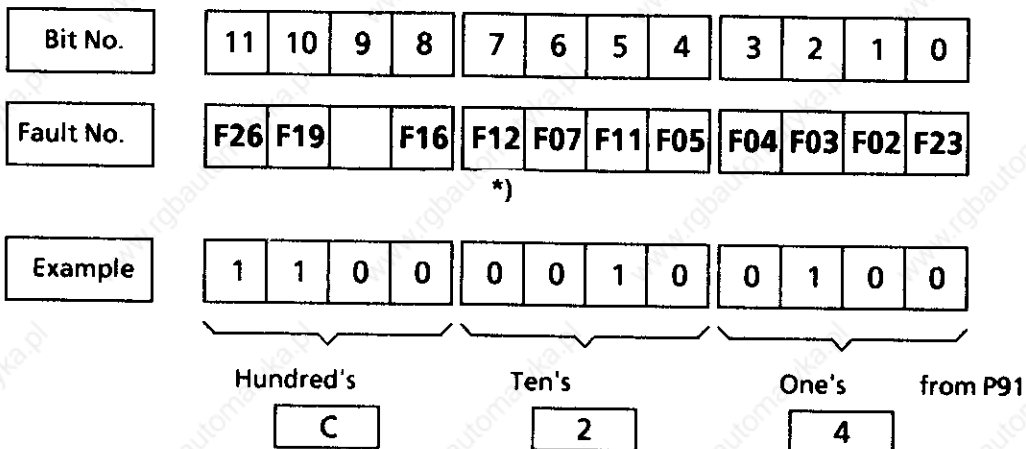

*) from SW 4.0

Bit = 0 ... Monitoring active
 Bit = 1 ... Monitoring disabled

Example: P91 = C24, i.e. F03, F11, F19 and F26 suppressed

Bit pattern	Hexadecimal
0000	0
0001	1
0010	2
0011	3
0100	4
0101	5
0110	6
0111	7

Bit pattern	Hexadecimal
1000	8
1001	9
1010	A
1011	B
1100	C
1101	D
1110	E
1111	F

Disabling other monitoring functions

- F10 (Overspeed protection) can be disabled with parameter E21 = 0.
- F13 (I²t monitoring) can be disabled with parameter P70 = 0.
- F14 (External fault) can be disabled with parameters P83 and P84 ≠ 15.
- F15 (Speed controller monitoring) can be disabled with parameter E03 = 1x.
- F16 (Anti-stall protection) can also be disabled with parameter P43 = 0.
- F34 (EEPROM fault) can be disabled via parameter P987 = 1x (permanent memory inhibit active).

10.14 Selecting the speed actual value

10.14.1 Operation with analog tachometer

The function is selected with parameter P53 = 0.
Connection, refer to Sections 6.1 and 6.8.

10.14.2 Operation with pulse encoder

The function is selected with parameter P53 = 1.

The following should also be set (also refer to Section 9.2 "Parameter description"):

- P54 Pulse encoder type
P55 and P56 Pulse encoder, pulse number (pulses/revolution)
P57 Control word for the pulse encoder
P58 and P59 Maximum speed with pulse encoder

Connection, refer to Sections 6.1 and 6.8.

The lowest measurable speed which can be measured with a pulse encoder is as follows:

$$n_{\min} [\text{RPM}] = 14648 * \frac{1}{X * IM}$$

where:

- X = 1 for 1x evaluation of the pulse encoder signals (P57 = 0)
2 for 2x evaluation of the pulse encoder signals (P57 = 1)
4 for 4x evaluation of the pulse encoder signals (P57 = 2)
also refer to "multiple evaluation of the encoder pulses"

IM = pulse encoder pulse number (pulses/revolution) → P55, P56

Lower speeds are evaluated as n = 0.

The frequency of the pulse encoder signals at terminals 28 and 29 or 30 and 31 must not exceed 100 kHz.

The highest speed which can be measured with a pulse encoder is calculated as follows:

$$n_{\max} [\text{RPM}] = \frac{6\,000\,000}{IM}$$

IM = Pulse encoder, pulse number (pulses/revolution) → P55, P56

When selecting the pulse encoder, it must be ensured, that the lowest speed ≠ 0 is significantly above n_{\min} and the highest speed is not above n_{\max} .

Thus:

$$IM >> \frac{14648}{X * n_{\min} [\text{RPM}]}$$

$$IM \leq \frac{6\,000\,000}{n_{\max} [\text{RPM}]}$$

When selecting the pulse number IM (pulses/revolution) of the pulse encoder.

Multiple evaluation of the encoder pulses

Also refer to Section 9.2 "Parameter description" for P54 and P57.

Pulse encoder type 1:

for 1x evaluation	Evaluation of the positive edges from track 1
for 2x evaluation	Evaluation of the negative edges from track 1
for 4x evaluation	Evaluation of the positive and negative edges from tracks 1 and 2

Pulse encoder type 2:

for 1x evaluation	Evaluation of the positive edges of the active track
for 2x evaluation	Evaluation of the positive and negative edges of the active track
4x evaluation	Not possible

Pulse encoder type 3:

for 1x evaluation	Evaluation of the positive edges of the pulse track
2x evaluation	Not possible
4x evaluation	Not possible

10.14.3 Operation without tachometer (closed-loop EMF control)

The function is selected with parameter P53 = 2.

The following should be set (also refer to Section 9.2 "Parameter description"):

- E33 IxR compensation
- E34 Maximum speed
- P20 Actual value filtering (as required)
Recommended value: P20 = 40 [ms]

Start-up

1. Setting the maximum speed with E34
2. With the motor running under no-load
Enter the setpoint
Measure motor speed
3. With the motor loaded
Increase the setting of parameter P33 until the speed is the same as the no-load speed.
4. If the drive doesn't go into status 07 at shutdown (terminal 37 open-circuit), and stays in status 01, increase P21.

NOTE

Closed-loop field weakening control is not possible when operating without a tachometer. Set P77 to 0!

10.15 Serial interface

The basic converter is equipped with a serial interface (G-SST1).

The interface at the 9-pin SUBMIN D socket X501 is an RS232 interface.

By connecting the optional interface expansion (6RX1240-0AL01) at G-SST1, the periphery has a RS485 interface instead of the RS232 interface (pin assignment of the interfaces, refer to "terminal assignment" in Section 6.8; connecting cable, refer to Section 10.15.3)

	G-SST1	G-SST1 1)	
Type	RS232	RS485 1)	
Connector	X501	X502 1)	
Operating mode 2)	RS232	4-wire operation:	2-wire operation:
	Not bus capable	Not bus capable	Bus capable
	Insert XJ2, XJ6, XJ7, XJ8 on A1660, into position 1-2	XJ2, XJ6, XJ7, XJ8 on A1660 for operation with A1618, insert in position 2-3	
Cable termination 3)	Not possible	Yes: XJ201 in setting 2-3 XJ200, XJ202 in setting 1-2	
		No: XJ201 in setting 1-2 XJ200, XJ202 in setting 2-3	

- 1) With the interface expansion option 6RX1240-0AL01 to convert from RS232 (on the converter side) to RS485.
- 2) Interface functions with P51 = 30, 31, 35, are not bus-capable, and automatically switch-over the interface to 4-wire operation. The USS protocol (P97 = 1xx or P97 = 2xx) automatically switches the interface to 2-wire operation.
- 3) 2-wire operation: Cable termination must only be activated at both converters at both ends of the bus cable.
4-wire operation: The cable termination should be activated at both receivers, which are next to both ends of the bus cable.

10.15.1 Parameter list output

The actual converter parameterization can be output on a printer with RS232- or RS485 interface or at a PC or PG.

Transfer to a printer:

Drive parameters can be transferred to a printer in any of the 6RA23 converter statuses.

		G-SST1 X501/X502 RS232/485
	The values set at the RA23 converter must match-up with the printer data. Please refer to the printer Instruction Manual for the printer setting.	Connecting cable, refer to Section 10.15.3
1.	Set the data transfer rates and data transfer protocol (function can be selected via P51) x baudrate	P97 = 01x
2.	Select the required function (all existing parameters printed-out) at P51	P51 = 30
3.	Start data transfer by depressing the MODE key on the 6RA23 Operating control panel: Operating control panel display: "III" jumps from left to right and the parameter is displayed which is presently being printed.	
4.	Manual abort of the data transfer Data transfer can be manually aborted by depressing the LOWER key on the converter. If a fault occurs during print-out, data transfer is immediately stopped.	

At the end of data transfer, the 6RA23 converter is in the actual operating status.

P51 is automatically reset from 30 to 0.



WARNING



An interface error (e.g. due to an incorrectly set data frame, a connected printed being switched-off with the interfaces selected etc.) means that the drive, possibly running, is shutdown! Thus, when in doubt, the interface should not be used in the "RUN" operating status.

Transfer to a PC (PG):

Parameters can be transferred from the converter to the PG (PC) when the converter is in any operating status.

The PCIN data transfer program (version ≥ 2.0) is required for data transfer on the PC side.

		G-SST1 X501/X502 RS232/485
	Establish the connection between the 6RA23 converter and PC (PG)	Refer to Section 10.15.3 for an example of the connecting cable
1.	Set the data transfer rate and data transfer protocol (function can be selected via P51) x baud rate	P97 = 01x
2.	Start the PCIN program at the PC (PG)	
3.	<p>Set the data transfer format and baud rate for the serial interface at the PC/PG Function key <F5> ... installation, function key <F3> ... interface</p> <p>PCIN must be configured as follows for the standard setting at the 6RA23 converter (P97 = 015):</p> <p>Baud rate 9600 Parity even Data bits 7 Stop bits 1</p>	
4.	<p>Set the PC/PG to receive Depress function key twice <F8> ... return to the main menu</p> <p>Function key <F3> ... file function, function key <F4> ... select receive</p> <p>Specify a file name and file type (may. 8 characters for the file name and 3 characters for the file type). The PC/PG is ready to receive after the <RETURN> key has been depressed.</p>	
5.	Select the required functions at P51 (parameter output at PC (PG)).	P51 = 31
6.	<p>Start file transfer by depressing the MODE key on the 6RA23 converter.</p> <p>Operating control panel display: "III" jumps from right to left and the parameter is displayed which is currently being transferred.</p>	

		G-SST1 X501/X502 RS232/485
7.	<p>Terminating data transfer</p> <p>The PC/PG ready to receive is automatically terminated and the complete drive parameter list saved under the specified file names and file type after the end ID "40 x <ZERO>" is received. If data transfer is manually aborted, then the drive parameters received up until then can also be saved by depressing function key <F8> at the PC/PG.</p> <p>Data transfer can be manually aborted by depressing the LOWER key on the 6RA23 converter.</p> <p>If a fault message occurs during "upreading" from the 6RA23 converter, then data transfer is immediately aborted.</p> <p>At the end of data transfer, the 6RA23 converter is in the presently current operating status.</p>	
8.	P51 is automatically reset to zero.	

Output is realized as follows:

ID (% T E A 1)

Header with software version No.

3 CR/LF

Parameter block

End ID "###" (for re-read-in)

End ID "40 x 0_H"

The PCIN program is signaled the end of the data set using the character sequence 40 x 0_H.

10.15.2 Read-in parameters

Parameters can be sent, for example, from a PC using the PCIN V2.0 interface program.

The function is selected via P51 = 35.

Parameters are then read-in from the serial interface and transferred, as long as the following syntax is maintained:

- 1 Data receive is activated by three consecutively received LF- or CR/LF characters. Everything in front of this (e.g. header) is ignored.
- 2 The actual parameter declaration is then realized in the following form:

Pyy = vvv [.nn]

Eyy = vvv [.nn]

Hyy = vvv [.nn]

Lyy = vvv [.nn]

A-H = vv

A-L = vv

SHI = vv

Explanation:

- yy Parameter number, this must be specified as two digit number (possible leading 0s).
 - = The "=" character can be separately specified, without, or using any number of <blanks> of parameter numbers and parameter values.
 - vvv Parameter value; for NIBBLE-coded parameters, the number of locations must be correct. Decimal parameters can be specified as required.
 - nn Positions after the decimal point for decimal parameters (if nothing is specified here, 00 is assumed)
- 3 Two parameters can be separated by a blank, slash, dotted line, CR, CR/LF or any combination.
 - 4 Read-in is completed, the RTS line reset again, and parameter mode selected with P51 = 0 when three "#" characters are consecutively received.

NOTE

The electronics power supply must remain switched-on for at least 3 minutes after the end of data transfer (with non-activated permanent memory inhibit, refer to P87 in Section 9.2) so that the new parameter values can be transferred into the permanent memory.

		G-SST1 X501/X502 RS232/485
	Establishing the connection between the 6RA23 drive converter and the PC (PG)	Example of the connecting cable, refer to Section 10.15.3
1.	Set the data transmission rate and data transfer protocol (function can be selected via P51) x ... baud rate	P97 = 01x
2.	Select the required function on the converter (read-in a parameter set)	P51 = 35
3.	Establish the read-to-receive status at the drive converter The converter is brought into the read-to-receive status by depressing the MODE key. Display: "III" jumps from right to left	
4.	Start the PCIN program at the PC (PG), and set the data transfer format and baud rate for the serial interface at the PC/PG. Function key <F5> ... installation, function key <F3> ... interface. PCIN must be configured as follows for the standard setting of the 6RA23 converter (P97 = 015): Baud rate 9600 Parity even Data bits 7 Stop bits 1	
5.	Set the PC/PG to send Depress function key <F8> twice... return to the main menu. Function key <F3> ... file function, function key <F6> ... select transmit Select the required file using the cursor keys.	
6.	Start data transfer by depressing the <Return> key on the PC/PG Display on the operator control panel: "III" jumps from right to left. The actual received parameter is displayed.	
7.	Ending data transfer The ready- to- receive status is automatically terminated after the "3 x <#>" end ID is received at the 6RA23 drive converter. Data transfer can be manually aborted by depressing the lower key on the 6RA23 drive converter. Note: If the "3 x <#>" is missing as end ID, then, when required, ready-to- receive can be manually aborted at the 6RA23 drive converter by depressing the LOWER key.	

If data transfer is manually aborted during "downloading" by depressing the LOWER key, then this can result in an inconsistency in the 6RA23 drive parameter data set. Thus, downloading must be immediately repeated!

At the end of the data transfer, the 6RA23 drive converter is in the actual operating status.

P51 is automatically reset from 35 to 0.

10.15.3 Connector assignments and connecting cables

Fig.1: Connecting cable between the 6RA23 converter (X501) and the PC with 9-pin SUBMIN D connector for the serial interface at the PC.

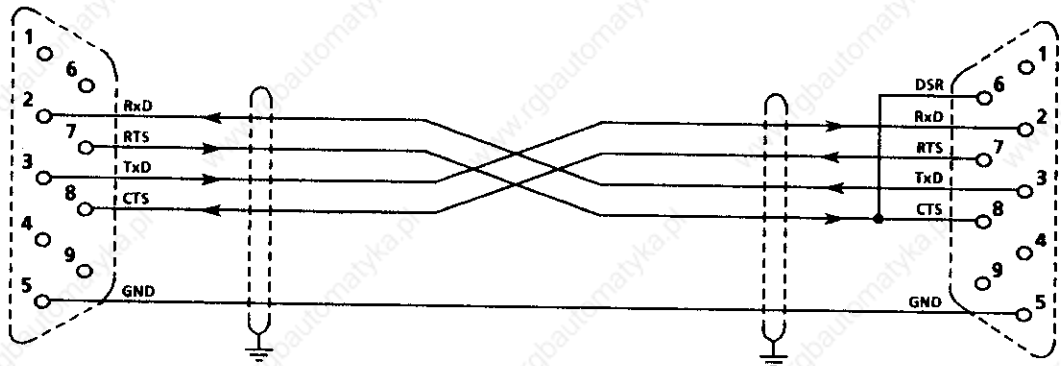

9-pin SUBMIN D connector
at the 6RA23 converter (X501): Socket
at the cable: Plug

Note:

For 6RA23 drive converters, neither a hardware handshake (CTS/RTS) nor a software handshake (XON/XOFF) have been implemented. The RTS control signal remains at the RS232 low signal level (+ 10 V) after power-up; the CTS control signal is not evaluated.

9-pin SUBMIN D connector for the serial interface
at the PC: Plug
at the cable: Socket

Note:

The connection of the CTS and DSR control signals is required by the PCIN data transfer program when sending.

Fig. 2: Connecting cable between the 6RA23 converter (X501) and the PC/PG with 25-pin SUBMIN D connector for the serial interface at the PC/PG

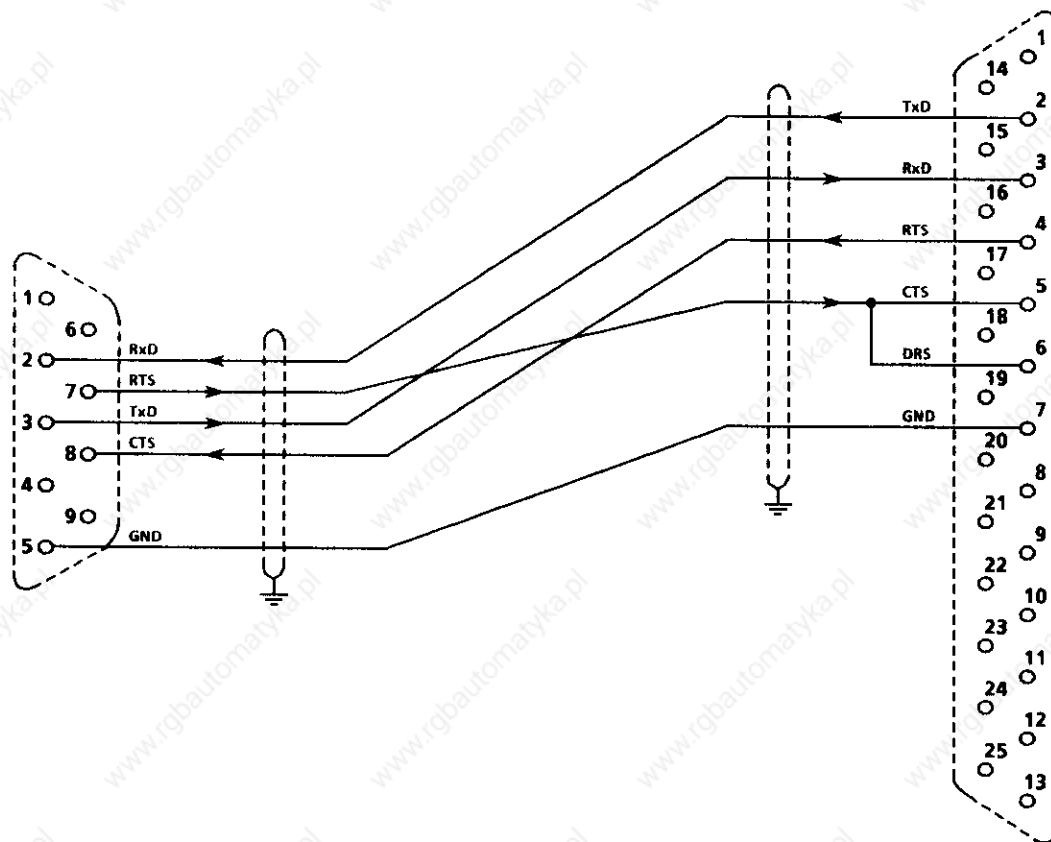

9-pin SUBMIN D connector at the 6RA23 converter (X501): Socket at the cable: Plug

25-pin SUBMIN D connector for the serial interface at the PC: Plug; at the PG: Socket at the cable: Socket or plug

Note:
For 6RA23 drive converters, neither a hardware handshake (CTS/RTS) nor a software handshake (XON/XOFF) have been implemented. The RTS control signal remains at the RS232 low signal level (+ 10 V) after power-up; the CTS control signal is not evaluated.

Note:
The connection of the CTS and DSR control signals is required by the PCIN data transfer program when sending.

Fig.3: Connecting cable between the 6RA23 converter (X501) and a printer with 25-pin SUBMIN D connector for the serial interface using as an example, an HP Thinkjet (RA232 version)

Note:

The HP Thinkjet printer is only shown here as an example. Any other printer can be used, as long as it has an RS232 interface.

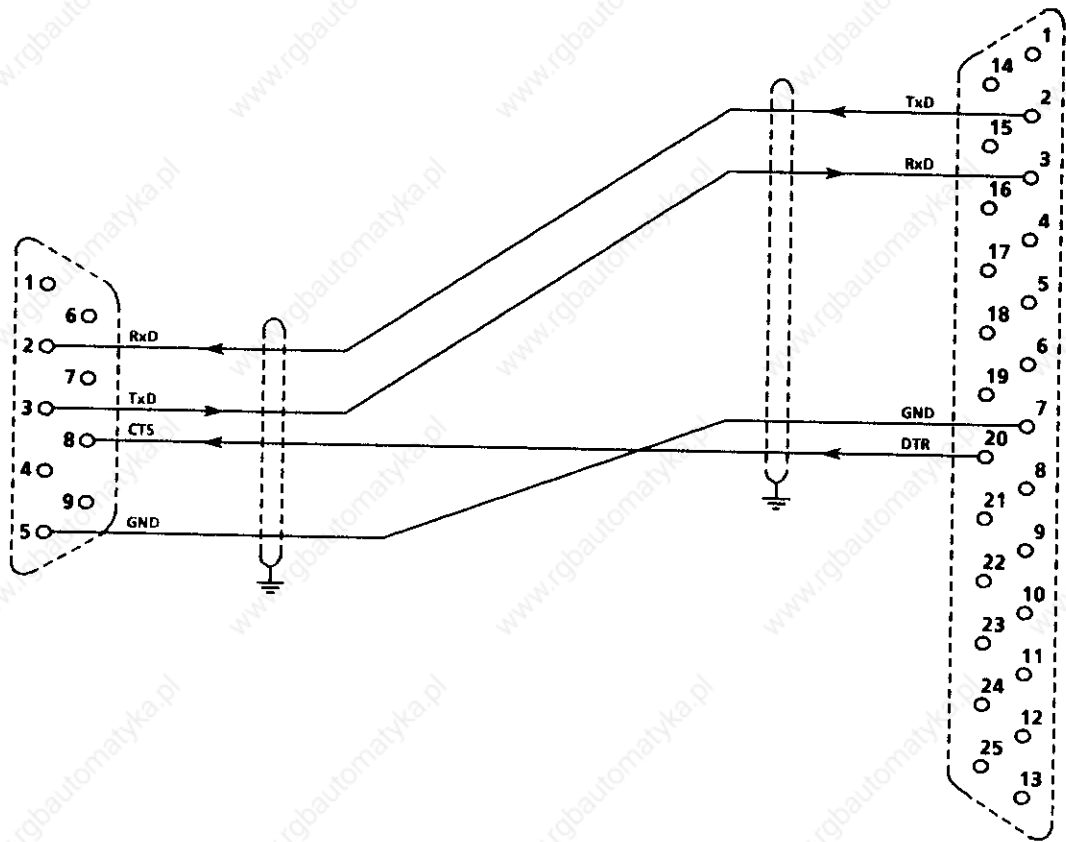

9-pin SUBMIN D connector
at the 6RA23 converter (X501): Socket
at the cable: Plug

25-pin SUBMIN D connector
for a serial interface
at the printer (HP Thinkjet): Socket
at the cable: Plug

Note:

For 6RA23 drive converters, neither a hardware handshake (CTS/RTS) nor a software handshake (XON/XOFF) have been implemented. The RTS control signal remains at the RS232 low signal level (+ 10 V) after power-up; the CTS control signal is not evaluated.

Fig.4: Connecting cable between two 6RA23 converters (X501) for a direct parameter transfer between the two converters via the RS232 interface

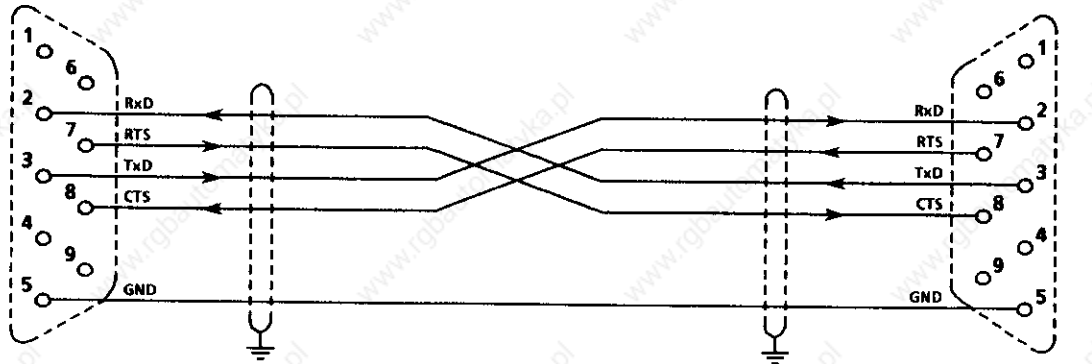

9-pin SUBMIN D connector at the 6RA23 converter (X501): Socket
at the cable: Plug

25-pin SUBMIN D connector at the 6RA23 converter (X501): Socket
at the cable: Plug

Note:

For 6RA23 drive converters, neither a hardware handshake (CTS/RTS) nor a software handshake (XON/XOFF) have been implemented. The RTS control signal remains at the RS232 low signal level (+ 10 V) after power-up; the CTS control signal is not evaluated.

Fig. 5: Connecting cable between two 6RA23 converters, each with an optional interface expansion C98043-A1618 (Order No.: 6RX1240-0AL01) (X502) for a direct parameter transfer between the two converters via the RS458 interface

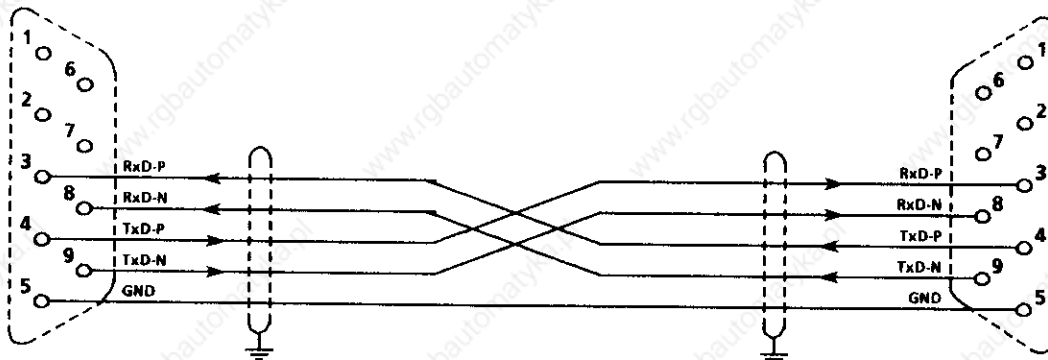

9-pin SUBMIN D connector at the 6RA23 converter with optional interface expansion C98043-A1618 (Order No.: 6RX1240-0AL01) (X502): Socket
at the cable: Plug

9-pin SUBMIN D connector at the 6RA23 converter with optional interface expansion C98043-A1618 (Order No.: 6RX1240-0AL01) (X502): Socket
at the cable: Plug

Note:

For 6RA23 drive converters, neither a hardware handshake (CTS/RTS) nor a software handshake (XON/XOFF) have been implemented. The RTS control signal remains at the RS232 low signal level (+ 10 V) after power-up; the CTS control signal is not evaluated. The CTS and RTS control signals are not evaluated on the optional C98043-A1618 interface expansion (Order No.: 6RX1240-0AL01).

10.16 External electronics power supply back-up (Faston connectors P24', N24', M)

Application

This maintains the bus- and the technology board functions during somewhat longer supply dips.

In order that the unit is immediately operable (to prevent technology board run-up times) as far as the technology boards and internal converter processors are concerned, during supply dips, the internal converter power supply can be externally buffered via the P24', N24', M Faston connectors on the A1662 PC board (15A converters) or A1663 (30 to 600 A converters). Current can only be injected but not drawn via Faston connections connectors P24', N24', M (de-coupling elements are incorporated in the unit).

The buffer voltages, are, for example, provided from an uninterruptable power supply.

The buffer voltage is best set at approx. 20 V, so that the buffer voltage only supports the system when the internal power supply either fails or dips.

This must not fall below 18 V, as otherwise the internal voltage monitoring function would respond. The terminals of the electronics power supply 5U1, 5V1, 5W1 must remain connected with the power section infeed, so that correct phase synchronization is guaranteed when the supply returns.

10.17 Recommended connections for external field supply converters

10.17.1 Recommended connection for an external field supply unit, SIEMENS MINIREG F10

The MINIREG F10 can be used together with 6RA23 converters as closed-loop field weakening controller.

Setpoint for the field supply converter

The field current setpoint is input via one of the analog select outputs (terminals 14 or 16) from the SIMOREG unit. For "0" setpoint, the field current should be set to "0" with the potentiometer "CURRENT" (R102) on the field supply converter (refer to MINIREG F10, Instruction Manual). The setpoint (0 to + 10 V), which corresponds to the rated field, should be set at the SIMOREG converter using normalization (P76).

Parameterization, refer to Section 7.5, start-up step 9.2

Controller enable for the field supply converter

The controller is enabled by connecting the internal control voltage to terminal X1.4 of the field supply unit. This can be realized using the internal 12 to 30 V control voltage (terminal X1.9) via a line contactor auxiliary contact.

Field current monitoring

A limit value monitor is provided in the field supply unit for monitoring the field current. If the field current falls below a minimum value, set using the potentiometer "CURRENT CONTROL" (R106), then the field supply unit signals this. The drive converter issues fault F14 if the field current falls below the reference value for longer than 4 seconds. The firing pulses are inhibited after the current has decayed to zero. To realize this, the field supply unit must be connected as recommended and the drive converter parameterized as follows.

Parameterization for field current monitoring

When using terminal 39 for the checkback signal: P83 = 15

When using terminal 40 for the checkback signal: P84 = 15

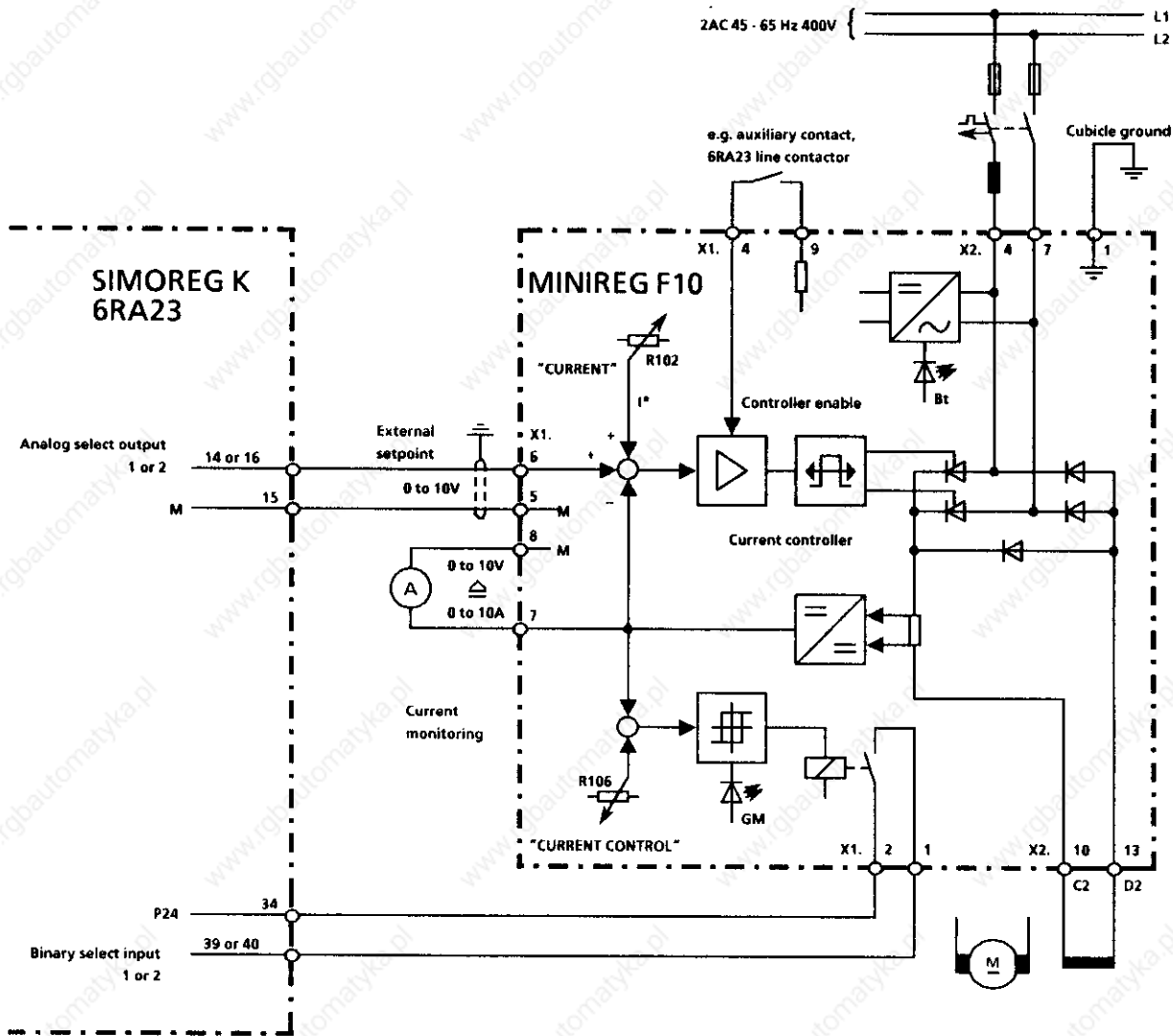

10.17.2 Recommended connection for the SIEMENS MINIREG F33 external field supply converter

The MINIREG F33 can be used together with 6RA23 converters as closed-loop field weakening controller.

Setpoint for the field supply converter

The field current setpoint is entered via one of the analog select outputs (terminal 14 or 16) from the SIMOREG converter. When setpoint "0" is input, the field current should be set to "0" with potentiometer R120 on the field supply converter. The setpoint (0 to +10 V), which corresponds to the rated field, should be set at the SIMOREG unit using normalization (P76), and/or using R121 on the field supply converter (refer to MINIREG F33, Instruction Manual).

Parameterization, refer to Section 7.5, start-up step 9.2

Controller enable for the field supply converter

The controller is enabled using the internal control voltage at terminal X1.4 of the field supply converter. To realize this, the internal P24 control voltage can, for example, be used (terminal X1.5), via a line contactor auxiliary contact.

Field current monitoring

A limit value monitor is provided in the field supply converter to monitor the field current. If the field current falls below a minimum value, set using potentiometer "CURRENT CONTROL" (R106), then the field supply unit signals this. The drive converter issues fault F14 if the field current falls below the reference value for longer than 4 seconds. The firing pulses are inhibited after the current has decayed to zero. To realized this, the field supply unit must be connected-up as recommended and the drive converter parameterized as follows.

Parameterization for field current monitoring

When using terminal 39 for the checkback signal: P83 = 15

When using terminal 40 for the checkback signal: P84 = 15

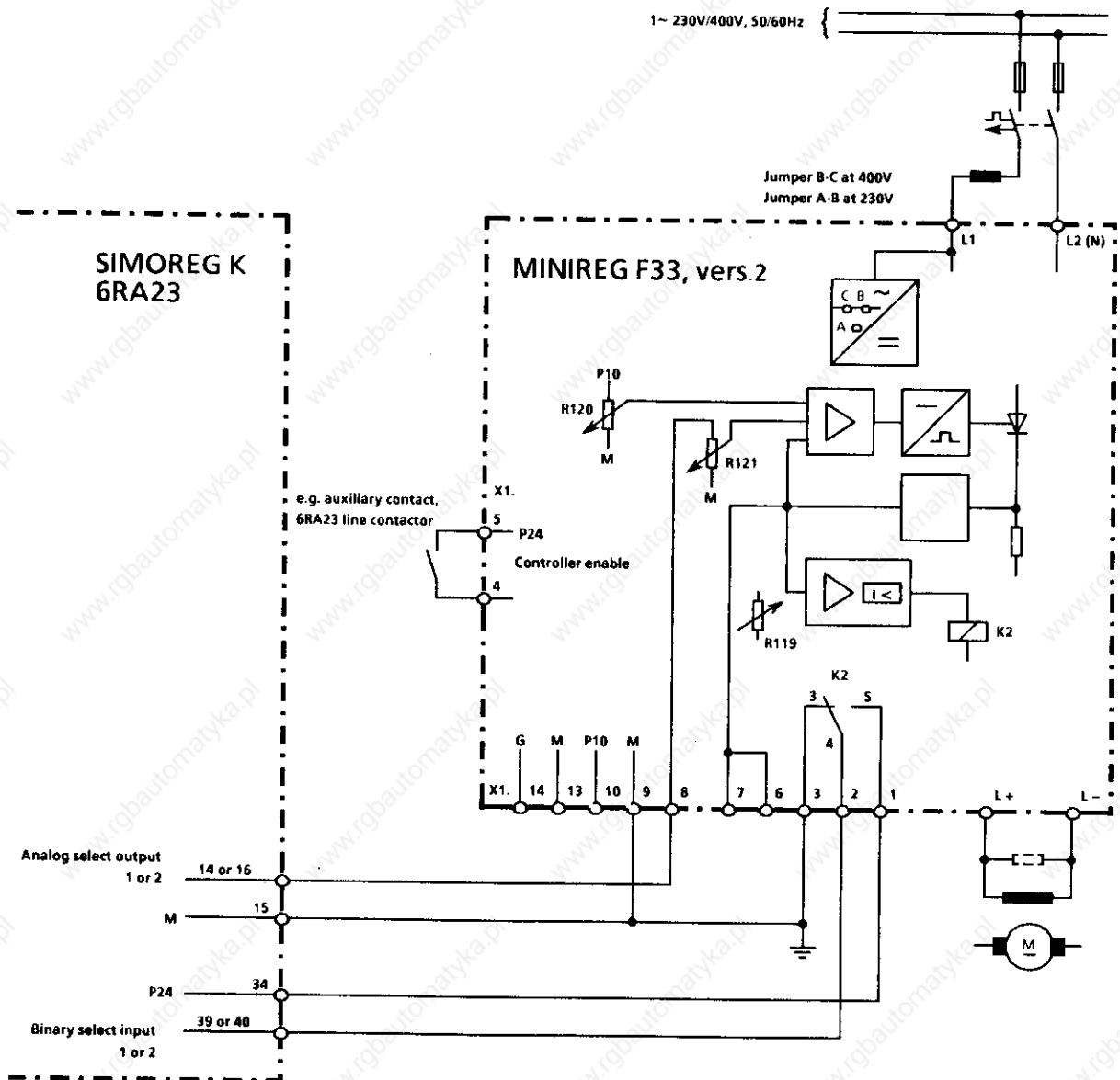

10.18 Digital interfaces

In addition to the binary and analog inputs and outputs, the 6RA23 SIMOREG K unit can also exchange data through digital interfaces.

Both PKW and PZD data can be exchanged via the digital interfaces.

PKW data: Reading and writing parameters

PZD data: Process data, such as control word, setpoints and status word, actual values

The DPR- and USS interfaces are available as digital interfaces.

DPR interface: Dual port RAM interface for data transfer with expansion boards (via connector X100) such as the supplementary technology board Z14 and/or the Z11 interface board.

USS interface: Data transfer via the USS protocol is possible via the basic converter serial interface (via X501) (from SW 4.0).

Note:

If the dual port RAM interface is selected via E00 = 8 or 9 the control word and setpoints are entered via the DPR interface.

The USS interface has a monitoring function for PZD data, and can read-out the status word and actual values.

It is possible to transfer PKW data (parameterization) simultaneously via DPR and USS.

10.18.1 USS protocol

from SW4.0

The USS protocol is implemented according to the following documentation:

"Specification of the universal serial interface protocol"

E20125-D0001-S302-A1

Special issues when implementing the function for 6RA23 converters:

to Section A-1:

The RS485 interface is available when using the 6RX1240-0AL01 interface converter. The 6RA23 drive converter does not support variable telegram lengths.

to Section A-2:

The broadcast mode is not provided for 6RA23.

to Section A-4:

The contents of the net data is specified in Section 10.18.1.1.

to Section A-4.2.1:

The 6RA23 drive converter does not support variable telegram lengths.

to Section A-4.2.2:

Quantity of net data, refer to Section 10.18.1.1

to Section A-4.3:

Address byte assignment, refer to Section 10.18.1.1.3

to Section A-5:

The ADR byte must always be transferred (also for point-to-point connections).

to Section A-5.2.1.2:

The 6RA23 converter does not support variable telegram lengths.

to Section A-5.2.3

Diagnostic function is not provided.

to Section A-5.4:

For 6RA23 converters, no special telegram processing.

to Section C-2

6RA23 drive converters do not support variable telegram lengths.

The contents of the net data is specified in Section 10.18.1.1.

to Section C-3:

PKW quantity is always 3; length of the PZD area, refer to Section 10.18.1.1

to Section C-3.1:

Baud rate setting, refer to P97.

Bus address setting, refer to P74.

Telegram failure time setting, refer to P75.

Setting, PKW-element quantity and PZD-element quantity eliminated.

to Section C-3.2:

Section not relevant.

to Section C-4, 4.1, 4.1.1, 4.1.2:

PKW area structure always as under Section 4.1.1 with parameter values as word quantities.

PKW area cannot be set to 0.

to Section C-4.2.1:

PKE bit 11 is not evaluated. There is no parameter change signal processing.

to Section C-4.2.1.1:

For 6RA23, the broadcast mode is not provided.

Task IDs and response IDs, refer to Section 10.18.1.1.1

All of the interfaces can change the parameters at any time. There are no PKW change rights.

to Section C-4.2.1.2:

The parameter change signal mechanism is not provided for 6RA24.

to Section C-4.2.2:

The index is not evaluated for 6RA23.

The index value, transmitted from 6RA23, is always 0.

to Section C-4.2.1.1, 4.2.2, 4.2.3:

In the task telegram, only task ID = 0000, 0001, 0010 and 1110 permitted.

In the task telegram, only task ID = 0000, 0001 and 0111 expected.

to Section C-5.1:

Length of the PZD area, refer to Section 10.18.1.1

to Section C-5.2.1:

Control word, refer to Section 10.18.1.1.2

Status word, refer to 10.18.1.1.2

to Section C-6:

Only a fixed telegram length possible (2 settings using P97)

The contents of the net data is specified in Section 10.18.1.1.

10.18.1.1 Telegram structure (also refer to E20125-D0001-S302-A1 Section A-4)

For 6RA23 drive converters, the hundreds location of two fixed telegram lengths can be set via P97.:

- P97 = 0xx ... USS protocol cancelled
- P97 = 1xx ... USS protocol, short telegram
- P97 = 2xx ... USS protocol, long telegram

Each telegram consists of:

- Start character (STX) 1 byte
- Length information (LGE) 1 byte
- Address byte (ADR) 1 byte (also refer to Section 10.18.1.1.3)
- n net characters (net data block) 10 / 22 bytes (short telegram/long telegram)
- Block check character (BCC) 1 byte

Short telegram

For short telegrams, the net data block includes a PKW area with three words and a PZD area with 2 words:

Task, master → slave (6RA23)		Response, slave (6RA23) → master	
E1	Parameter ID (PKE)	S1	Parameter ID (PKE)
E2	Index	S2	Index
E3	Parameter value (PWE)	S3	Parameter value (PWE)
E4	Control word	S4	Status word
E5	n set / i set	S5	Select signal0

E1, E2, E3 or S1, S2, S3 = PKW area
E4, E5 or S4, S5 = PZD area

Long telegram

For long telegrams, the net data block includes a PKW area with three words and a PZD area with 8 words:

Task, master → slave (6RA23)		Response, slave (6RA23) → master	
E1	Parameter ID (PKE)	S1	Parameter ID (PKE)
E2	Index	S2	Index
E3	Parameter value (PWE)	S3	Parameter value (PWE)
E4	Control word	S4	Status word
E5	n set / i set	S5	Select signal 0
E6	I_SET SUPPLEMENTARY	S6	I-act
E7	I_FIELD SET	S7	PHI
E8	B +	S8	Select signal 1
E9	B-	S9	Select signal 2
E10	N_ACT_1	S10	N_SET
E11	N_SET SUPPLEMENTARY	S11	Par. number (PA_REG)

E1, E2, E3 or S1, S2, S3 = PKW area
E4 to E11 or S4 to S11 = PZD area

10.18.1.1.1 Net data block - PKW area

E1, E2, E3 or S1, S2, S3

also refer to E20125-D0001-S302-A1

Task, master → slave (6RA23)	Response, slave (6RA23) → master
<p>E1 - parameter ID (PKE):</p> <p>Bits 0 to 10 = parameter No. (PNU) *) Bit 11 = 0 (SP) Bits 12 to 15 = task ID (AK)</p> <p>Legal task IDs: Bits 15, 14, 13, 12 =</p> <p>0000 ... no task 0001 ... request parameter value 0010 ... change parameter value 1110 ... change parameter value and store in the EEPROM</p>	<p>S1 - parameter ID (PKE):</p> <p>Bits 0 to 10 = parameter No. (PNU) *) Bit 11 = 0 (SP) Bits 12 to 15 = response ID</p> <p>Possible response IDs: Bits 15, 14, 13, 12 =</p> <p>0000 ... no task for AK = 0000 0001 ... transfer parameter value for AK = 0001, 0010 and 1110 0111 ... task cannot be executed for AK = 0010 and 1110 if the para- meter value lies outside the limits or there is a request to change a parameter which cannot be chan- ged (e.g. display parameter) and for an illegal task ID</p>
<p>E2 - index (IND): (for 6RA23, always 0)</p>	<p>S2 - index (IND): (always 0 for 6RA23)</p>
<p>E3 - parameter value (PWE):</p> <p>The required parameter value multiplied by a factor corresponding to its lowest stage stop, must be transferred. The parameter steps can be seen from the parameter description in Section 9.2 (in brac- kets after the value range):</p> <p>Steps = 1 → factor = 1 0.1 → 10 0.01 → 100</p>	<p>S3 - parameter value (PWE):</p> <p>The value of the requested parameter, mul- tiplied by a factor corresponding to its lo- west step, is transferred. The parameter steps can be seen from the parameter de- scription in Section 9.2 (in brackets after the value range):</p> <p>Steps = 1 → factor = 1 0.1 → 10 0.01 → 100</p> <p>For response ID = 0111, the error ID is ente- red into S3 instead of a parameter value:</p> <p>0 ... illegal parameter number 1 ... parameter cannot be changed 2 ... lower or upper value limit violated 5 ... erroneous data type</p>

*) Parameter number: P00 ... P99 → PNU = 0 ... 99
 E00 ... E87 → PNU = 100 ... 187
 d00 ... d30 → PNU = 200 ... 237
 H00 ... H89 → PNU = 300 ... 389
 L00 ... L34 → PNU = 400 ... 434

Example:

Parameter P11 should be set to 12%, and also stored in the EEPROM:

Task telegram (PKW area):

E1 - parameter ID (PKE):

AK: Bits 15, 14, 13, 12 = 1110 (binary)
 (= change parameter value and store in the EEPROM)
 SP: Bit 11 = 0
 PNU: Bits 10 ... 0 = 00000001011 (binary) = 11 (decimal) (= parameter No.)
 thus PKE: = 1110 0000 0000 1011 binary = E00B (hexadecimal)

E2 - index (IND):

IND: = 0

E3 - parameter value (PWE):

According to the Instruction Manual, Section 9.2, parameter P11 has a resolution of 0.1%. Thus, the required parameter value (12) must be multiplied by 10.

thus PWE: = 120 (decimal)

Thus, the following is realized in the response telegram (PKW area) after a task has been executed in the basic drive converter (6RA23).

S1 - parameter ID (PKE):

PKE = 100B (hexadecimal) = 0001 0000 0000 1011 (binary)
 AK: Bits 15, 14, 13, 12 = 0001 (binary) (= transfer parameter value)
 SP: Bit 11 = 0
 PNU: Bits 10 ... 0 = 00000001011 (binary) (= transfer parameter value)

S2 - Index (IND):

IND = 0

S3 - parameter value (PWE):

PWE = 120 (decimal)

According to the Instruction Manual, Section 9.2, parameter P11 has a resolution of 0.1%. In order to calculate the actual parameter value, the parameter value signaled back (120) must be divided by 10.

Parameter value = 12.0



WARNING



After the end of data transfer, it can still take up to 3 minutes until all parameters are stored in the EEPROM. It is not permissible to switch-off the electronics power supply in this time. If the power supply is switched-off, then "read-in parameter" must be repeated!

CAUTION

Only a limited number of EEPROM write access are permitted within its lifetime (10000).

Thus, frequent value parameter changes via interfaces (the serial basic converter interface or cyclic parameter value changes via supplementary boards) should, if possible, only be realized in the RAM, and not also in the EEPROM.

For parameter changes via the interface, there is a task "change parameter value (and do not store in the EEPROM)" (if the value is only changed in the RAM, then the thus modified values are lost when the electronics power supply is switched-off).

10.18.1.1.2 Net data block - PZD area

E4, E5 or S4, S5 for short telegrams
E4 to E11 or S4 to S11 for long telegrams

E4 control word:
(also refer to "binary input functions" in Section 10.2)

Bit			Function
0	0 1	OFF1 ON	Shutdown Power-up
1	0 1	OFF2	Disconnect voltage No voltage disconnect
2	0 1	OFF3	Fast stop No fast stop
3	0 1		No operating enable Operating enable
4	0 1		No ramp-function generator enable Ramp-function generator enable
5	0 1		Ramp-function generator STOP No ramp-function generator STOP
6			Not used for 6RA23 drive converters
7	0 1		No significance Fault acknowledge
8	0 1		Inching 1 OFF Inching 1 ON
9	0 1		Inching 2 OFF Inching 2 ON
10			Not used for 6RA23 drive converters
11	0 1		Ramp-function generator 1 Ramp-function generator 2
12	0 1		Motorized potentiometer OFF Motorized potentiometer ON
13	0 1		0 = Mot. potentiometer, clockwise rotation 1 = Mot. potentiometer, counter-clockwise rotation
14	1		Motorized potentiometer, RAISE
15	1		Motorized potentiometer, LOWER

E5 - n-set/ I-set (digital setpoint):

Speed = / current setpoint depending on the controller configuration
Intervention point, refer to Section 10.1, Sheet 6

Normalization:

n-set	-100 % n-max	-16384
	100 % n-max	16384
	(n-max = max. speed)		
I-set	-100 % I limit	-16384 (torque direction I)
	100 % I limit	16384 (torque direction II)
	(I limit = converter limiting current)		

E6 - I_SET_SUPPLEMENTARY:

Supplementary current setpoint

Intervention point, refer to Section 10.1, Sheet 9

Normalization: 3200 Rated converter current in torque direction I
 -3200 Rated converter current in torque direction II

E7 - I_FIELD_SET:

Field current setpoint for an external controlled field supply unit.

Intervention point, refer to Section 10.1, sheet 11

Normalization: 0 Field current setpoint = 0
 255 Field current setpoint is equal to the value set in P76

E8 - B + :

Positive current limit

Intervention point, refer to Section 10.1, Sheet 9

Normalization: + 16384 System current in torque direction I
 (i.e. the higher of the values selected in P39 and P40 corresponds to + 16384).
 The function is signed (as for the analog select input)

E9 - B - :

Negative current limit

Intervention point, refer to Section 10.1 Sheet 9

Normalization: + 16384 System current in torque direction II
 (i.e. the higher of the values selected in P39 and P40 corresponds to + 16384).
 The function is signed (as for the analog select input)

E10 - N_ACT_1:

Digital speed actual value

Intervention point, refer to Section 10.1, Sheet 2

Normalization: 100 % n-max - 16384
 -100 % n-max + 16384
 (n-max = max. speed)

E11 - N_SET_SUPPLEMENTARY:

Supplementary speed setpoint

Intervention point, refer to Section 10.1, Sheet 8

Normalization: 100 % n-max 16384
 -100 % n-max -16384
 (n-max = max. speed)

S4 - status word:

Bit		Function	
0	0 1	Not ready-to-switch-on Ready to switch-on	Operating status o7
1	0 1	Not ready Ready	Operating status o1
2	0 1	Operation inhibited Operation enabled	Operating status I, II, --
3	0 1	Fault-free Fault	
4	0 1	Voltage disconnect (OFF2) No voltage disconnect	Operating status o6 (LOW active)
5	0 1	Fast stop (OFF3) No fast stop	Operating status o8 (LOW active)
6	0 1	No switch-on inhibit Switch-on inhibit	Operating status o6, o8
7	0	For 6RA23 drive converters, not used	
8	0	For 6RA23 drive converters, not used	
9	1	For 6RA23, always 1	
10	0 1	$n < n\text{-min} [P21]$ $n > n\text{-min} [P21] + \text{hysteresis} (0.5 \%)$	
11	0	For 6RA23 drive converters, not used	
12	0	For 6RA23 drive converters, not used	
13	0	For 6RA23 drive converters, not used	
14	0	For 6RA23 drive converters, not used	
15	0	For 6RA23 drive converters, not used	

Status description of several bits in the status word

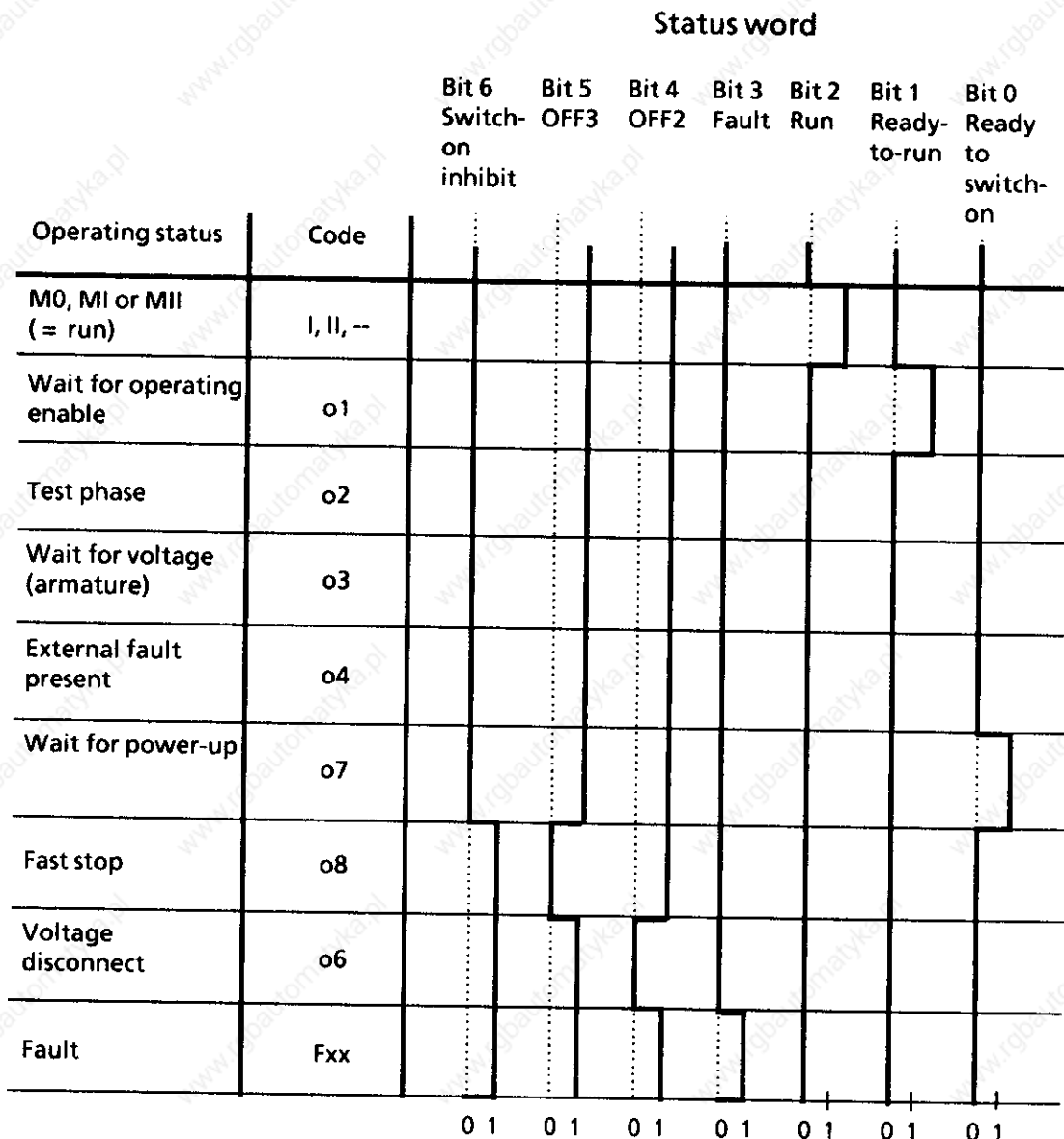

S5 select signal 0:

The returned signal is selected using E72 (also refer to Section 9.2)

Normalization for E72 = 0, 3, 4 and 5:

100 % n-max 16384
 -100 % n-max -16384
 (n-max = max. speed)

Normalization for E72 = 1:

3200 100 % Rated converter current

S6 - I-act:

Absolute current actual value (internal designation LAVERAGE)

Normalization: 3200 100 % Rated converter current

S7 - PHI:

Checkback signal of the magnetic flux used to calculate the torque (internal designation K_PHI)

The normalization is obtained from the definition of K_PHI :

$$K_PHI = \frac{EMF \cdot 65536}{N_ACT} = \frac{400 \cdot EMF [in V]}{N_ACT [in \% N_MAX]}$$

$K_PHI = 1360$ for $EMF = 340 V$ and $100 \% N_MAX$
 K_PHI lies in the range from 0 ... 32767.

S8 - select signal 1:

Selects the returned signal with E73

S9 - select signal 2:

Selects the returned signal with E74

S10 - N_SET:

Analog setpoint is signaled back at terminals 4 and 5 (main setpoint), refer to Section 10.1, Sheet 2

Normalization: 100 % n-max 16384
 -100 % n-max -16384
 (n-max = max. speed)

S11 - PA_REG:

Number of the parameter selected via the operator control unit

10.18.1.1.3 Address byte (ADR)

Address byte assignment in the task telegram (master → 6RA23)

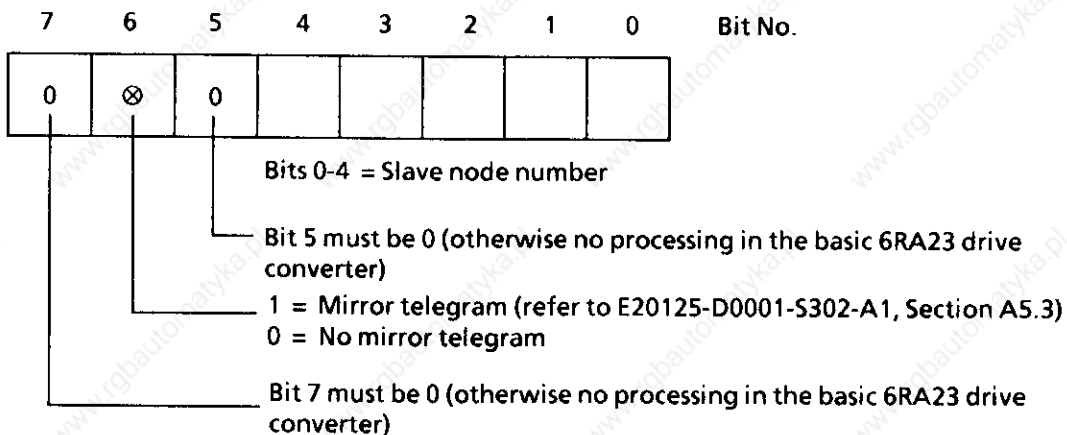

The slave node number must be the same as the address selected at parameter P74.

The address byte is returned, unchanged in the response telegram (6RA23 → master).

10.18.1.2 Start-up

Note: If the USS protocol is selected using parameter P97, it only becomes effective if the P mode is selected (display "P97", refer to Section 7.3).

- **Telegram length**
Set using parameter P97, hundred's location (refer to Section 10.18.1.1)
- **Baud rate**
Set using parameter P97, one's location (refer to Section 9.2)
- **Data transfer format**
When the USS protocol is selected, the data transfer format is automatically set to an eleven-bit frame with 1 start bit, eight data bits + 1 parity bit, 1 stop bit, even parity. Thus, it is irrelevant if the ten's location of parameter P97 is set.
- **Node address**
Set using parameter P74 (refer to Section 9.2)
- **Telegram failure time**
Set using parameter P75 (refer to Section 9.2)
- **Bus-/point-to-point connection**
The serial G-SST1 basic converter interface at connector X501 is an RS232 interface. Thus, only point-to-point operation (e.g. PC ↔ SIMOREG 6RA23) is possible. A bus connection can be established as RS485 bus with the optional C98043-A1618 interface expansion (Order No. 6RX1240-0AL01).
- **Plug-in jumpers**
RS232: XJ2, XJ6, XJ7 and XJ8 in setting 1-2
RS485: XJ2, XJ6, XJ7 and XJ8 in setting 2-3
- **Cable**
RS232:
Universal cable (for PCIN, SIMOVIS, ...) as in Section 10.15.3, Fig. 1, according to the following arrangement:

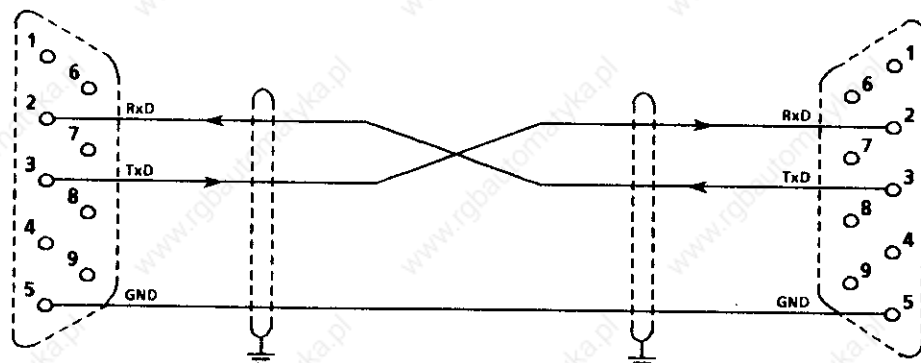

9-pin SUBMIN D connector
at the 6RA23 converter X501: Socket
at the cable: Plug connector

PC serial interface
COM1 or COM2
9-pin SUBMIN D connector
at the PC: Plug connector
at the cable: Socket

RS485:

Connecting cable between the 6RA23 converter with the optional 6RX1240-0AL01 interface expansion at X501 and the CP524 communications processor with RS485 interface module:

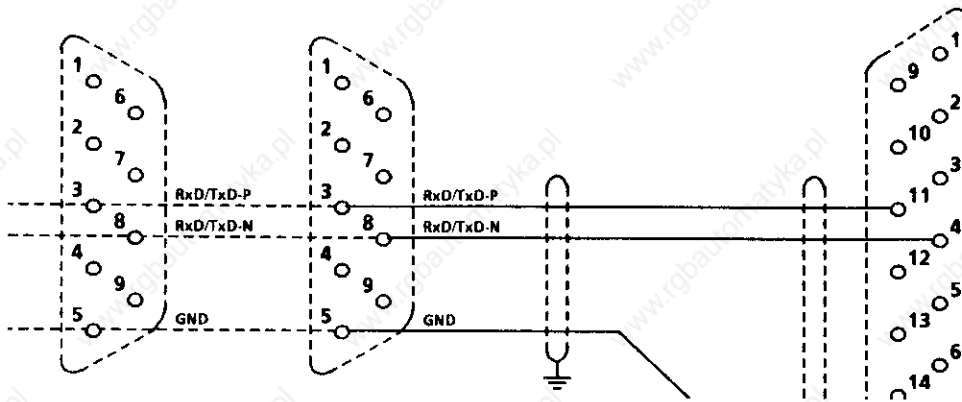

9-pin SUBMIN D connector
at the 6RA23 converter with 6RX1240-0AL01: Socket
at the cable: Plug connector
Possibly existing additional bus nodes are connected in parallel in the same fashion.

CP524 with RS485 interface module
1-pin SUBMIN D connector
at the CP524: Socket
at the cable: Plug

Connecting cable between the 6RA23 converter with optional 6RX1240-0AL01 interface expansion at X501 and PC with RS485 interface:

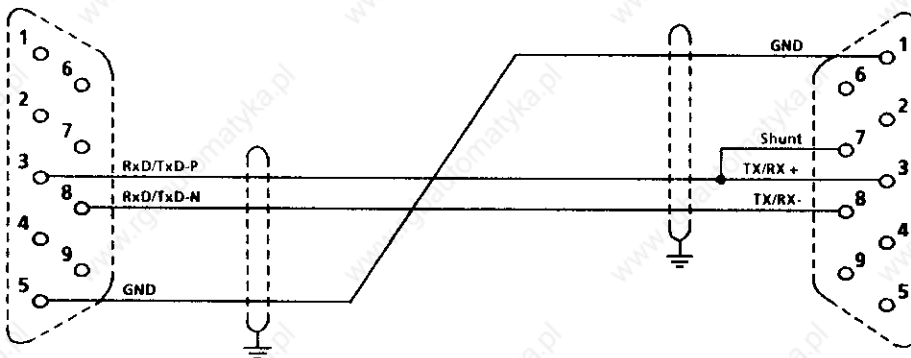

9-pin SUBMIN D connector
at the 6RA23 converter with 6RX1240-0AL01: Socket
at the cable: Plug

PC RS485 interface
Card, Messrs.Kolter
9-pin SUBMIN D connector
at the PC RS485 interface: Socket
at the cable: Plug

10.18.2 Dual port RAM interface

Refer to the Instruction Manual of the connected supplementary board (technology board Z14 and/or interface board Z11).

10.19 Motorized potentiometer

The motorized potentiometer function can be selected via the USS protocol at X501 or via a supplementary board via the dual port RAM interface.

The control bits are as follows:

Function	USS protocol	DPRAM interface
Mot. potentiometer, ON	Control word (E4) bit 12	Control word (E3) bit 10
Mot. pot., CW/CCW	Control word (E4) bit 13	Control word (E3) bit 11
Mot. potentiometer, RAISE	Control word (E4) bit 14	Control word (E3) bit 13
Mot. potentiometer, LOWER	Control word (E4) bit 15	Control word (E3) bit 15

Also refer to Section 10.1, Sheet 6

Motorized potentiometer, ON

If the "motorized potentiometer ON" bit is set to 1, the drive converter changes over from automatic operation (main setpoint or digital setpoint) to manual operation. The ramp-function generator is stopped and the setpoint can now be changed using RAISE and LOWER, whereby the rate of change is the ramp-function generator time.

Motorized potentiometer, OFF

If the "motorized potentiometer ON" bit is set to 0, then the "motorized potentiometer" function is switched-out. Automatic operation is re-selected (main setpoint or digital setpoint).

Motorized potentiometer, CLOCKWISE/COUNTER-CLOCKWISE

If the "motorized potentiometer, clockwise/counter-clockwise" bit is set to 1, in manual operation (motorized potentiometer ON = 1), the motor direction of rotation is changed to counter-clockwise (bit = 0 → clockwise).

Motorized potentiometer, RAISE

If the "motorized potentiometer, RAISE" bit is set to 1, in manual operation (motorized potentiometer ON = 1), the setpoint is changed towards a higher speed.

Motorized potentiometer, LOWER

If the "motorized potentiometer LOWER" bit is set to 1, in manual operation (motorized potentiometer ON = 1), the setpoint is changed towards speed = 0.

For operation with motorized potentiometer, parameter E20 can be used to select whether the motorized potentiometer setpoint is stored in the EEPROM when the drive converter is shutdown.

11. Maintenance



WARNING

This converter contains hazardous voltage levels.

On the customer side, hazardous voltages can be present at the signaling relays.

Death, severe bodily injury and significant material damage can occur if these converters are not handled professionally by trained personnel.

Thus, please always observe the instructions provided in this section and on the product itself when carrying out maintenance/service work on the converters.



- Service/maintenance on the converter must only be carried-out by appropriately qualified personnel who, prior to any work, must be familiar with all of the safety information provided in these instructions as well as the installation, operation and maintenance instructions.
- Before carrying-out visual checks and maintenance work, ensure that the AC power supply is disconnected and locked-out, and that the converter is grounded. Both the converter as well as the motor have hazardous voltage levels before the AC power supply is disconnected. Even though the converter contactor is open, dangerous voltage levels are still present.
- Only spare parts authorized by the manufacturer must be used.

The converter should be protected from dirt, in order to prevent voltage flashovers and thus destruction. Dust and foreign bodies, which are drawn in through the cooling air flow, should be removed at regular intervals depending on the degree of pollution, but at least every twelve months. The converter should be cleaned using dry compressed air, max. 1 bar, or with an industrial vacuum cleaner.

For converters with forced-ventilation the following should be observed:

The fan bearings are designed for a service lifetime of 30000 hours. They should be replaced in plenty of time so that the availability of the thyristor sets is maintained

11.1 Procedure when replacing software (upgrading to a new software release)

- 1 Read-out and document all parameter contents.

Note:
The parameter set can be printed-out via the G-SST1 interface (connector X501), or downloaded into a PC or PG (refer to Section 10.15).
- 2 Switch-off the electronics power supply
- 3 Remove the hardware write protection. To realized this, place plug-in jumper XJ1 into position 1-2 on the electronics board.
- 4 Remove EPROMs D17, D18 from their sockets on board A1660, and insert the new EPROMs into the sockets.

Caution:
D17: Designation - . 101
D18: Designation - . 102
- 5 Check that the notches on the EPROMs matches up with the markings on the PC board, and that all pins are actually inserted in the socket.
- 6 **Caution:** When the electronics power supply is switched-on again, it is possible that all of the parameter contents are lost!
- 7 Switch-on the electronics power supply
- 8 Acknowledge a possibly occuring fault message
- 9 Establish the factory setting
(refer to Section 7.4)
- 10 Commission the drive converter
(refer to Sections 7.5, 7.6, 7.7)

The parameter set, stored in Section 1 can be read from a PC or PG via the G-SST1 serial interface (refer to Section 10.15).
- 11 **End**

12. Service

NOTE

For 30A to 600A converters:

When replacing the power interface board A1663, when troubleshooting, it is recommended that the complete field terminal block XF is unscrewed from the board to be replaced, without disconnecting the connecting wires (2 retaining screws), which is then subsequently mounted on the replacement board. Screw the empty terminal again on the defective board.

Advantage: Reduces cabling work and of course faults.

13. Spare parts

Please refer to Catalog DA21E for information regarding spare parts.

NOTE

When making inquiries, always specify the following converter data:

- Converter Order No. and serial No.
- Software release
- Hardware version of the basic electronics board (printed on the component side)
- Hardware version and software release of supplementary boards (if available)

14. Appendix

14.1 Additional documentation

Circuit manual for 1Q-converters:

Order No.: C98130-A1203-A1-*--22

Circuit manual for 4Q-converters:

Order No.: C98130-A1205-A1-*--22

Catalog DA21

Converters

Catalog DA21E

Spare parts

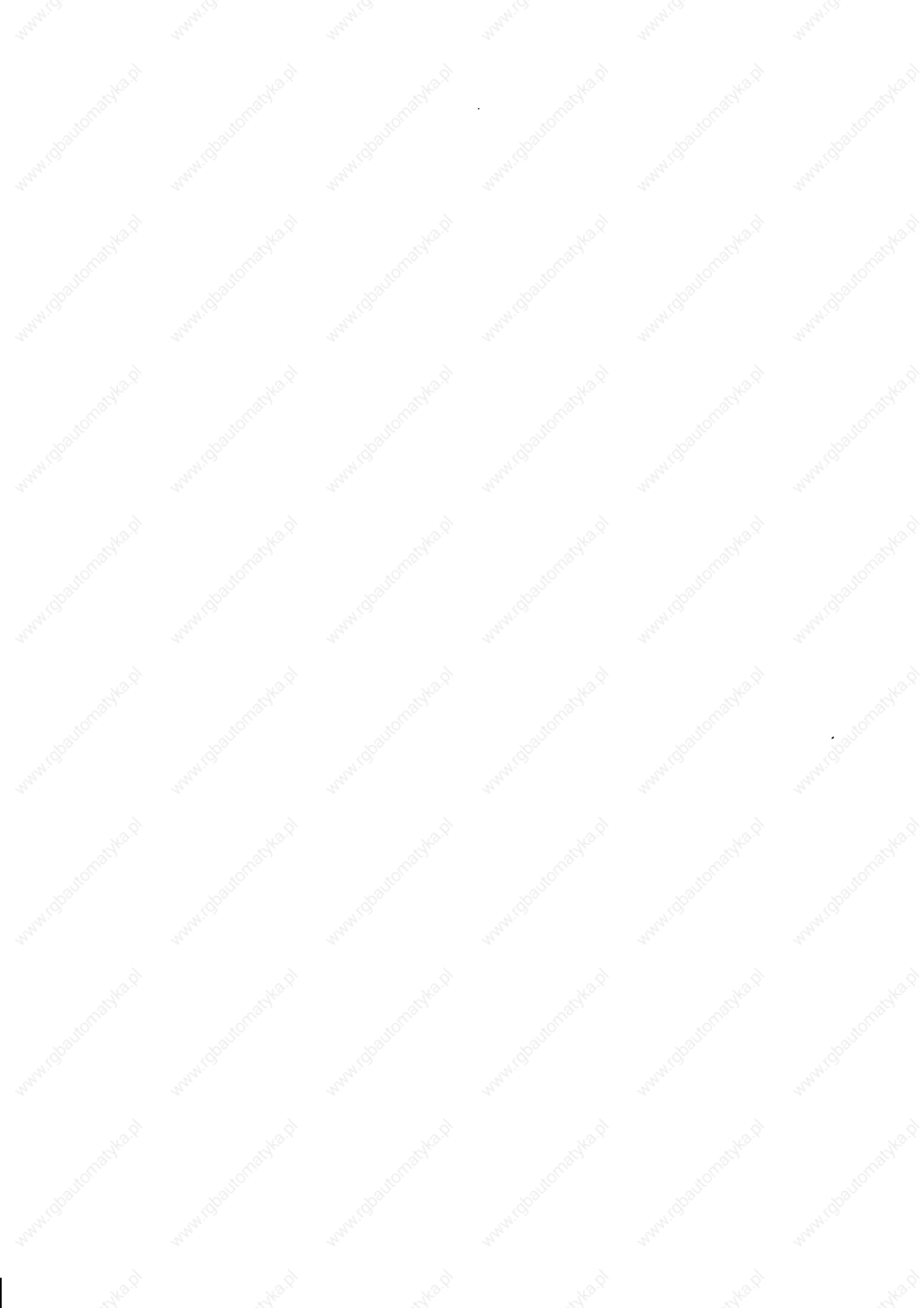

15. SIMOVIS for 6RA23

from SW4.00



WARNING



Only qualified personnel, who are knowledgeable about these operating instructions as well as the Instruction Manual for SIMOREG converters may commission the converter using a PC.

If the PC software is not competently handled, the drive can be operated outside the specified operating points. This could lead to severe bodily injury and significant material damage.

When using the control (open-loop function), the drive may start by itself.

15.1 What can SIMOVIS do?

- Menu-prompted start-up
- UPREADING / DOWNLOADING parameter sets
- Prompted parameterization of the analog and binary inputs and outputs
- Prompted setting of all open- and closed-loop control functions (motorized potentiometer, ramp-function generator, speed controller, current setpoint generation, current controller, EMF control, field current controller)
- Prompted parameterization of supplementary boards
- Operating mask to enter control commands and setpoints

15.2 Commissioning SIMOVIS

15.2.1 System requirements

SIMOVIS must be installed on a hard disk and requires the following platform:

- PC with processor \geq 80386
- MS-DOS \geq 5.0
- 3.5" floppy disk drive, 1.44 Mbyte
- 5 Mbyte of free memory on the hard disk
- 552 Kbyte RAM (approx. 566000 bytes)
- VGA graphics
- Serial interface
- Mouse is recommended

15.2.2 Transferring software onto the hard disk

Define a SIMOVIS master directory with any name and change into this directory.

Example for a master directory called SIMOVIS (MS DOS commands):

```
C:
MD SIMOVIS
CD SIMOVIS
```

Insert the first floppy disk with the required language in the drive (e.g. A:) and enter:

```
A:INSTALL
```

The required directory structure is set-up, and the files copied onto the hard disk. This lasts several minutes.

If various converters or control versions (e.g. 6RA23, 6SE70-FC, 6SE70-VC,...) are to be operated on one USS bus, the appropriate floppy disks must be installed one after another in the same master directory as described above.

15.2.3 Establishing the connection between the PC and 6RA23

NOTE

SIMOVIS communicates with the 6RA23 drive converter via the USS protocol.

Parameter P92 must therefore be set to 135 (short telegram).

The connection between the 6RA23 converter and the PC is established using a cable as illustrated in Section 10... Fig. 2 (universal cable for PCIN, SIMOVIS for diagnostics monitor), or as shown below:

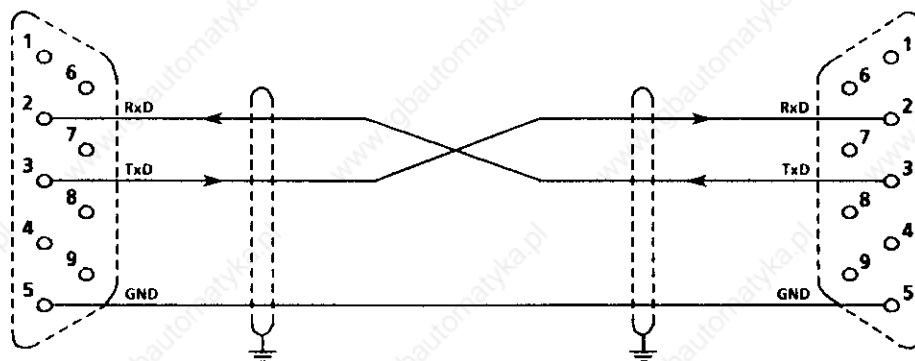

9-pin SUBMIN D connector
at the 6RA23 converter X501: Socket
at the cable: Plug

PC serial interface
COM1 or COM2
9-pin SUBMIN D connector
at the PC: Plug
at the cable: Socket

The plug-in jumpers for the RS232 interface X501 should be set as follows on the A1600 electronics board of the 6RA24 converter (this setting corresponds to the setting when the unit is shipped, refer to Section 6.8):

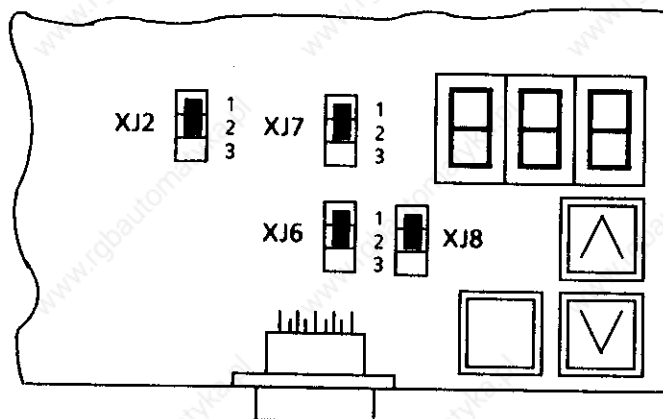

15.2.4 Starting SIMOVIS

SIMOVIS, depending on the serial interface, can be started with

START1, if COM1 is used, or
START2, if COM2 is used

A mask is then displayed, which can be used to define the slave configuration (refer to Section 15.2.6), the baud rate.

After the first installation, a 6RA23 converter, with converter address 0 is pre-set as single converter at 9600 baud.

If error message "RAM too small" is displayed after the run time program is loaded, more RAM should be provided by appropriately modifying the CONFIG.SYS and AUTOEXEC.BAT files (deactivating drivers and auxiliary programs which are not used).

15.2.5 Mouse replacement

If a mouse is not found when the PC is run-up, SIMOVIS provides a function, which allows the mouse pointer to be moved using the cursor keys:

Alt - cursor right	:	One position to the right
Alt - cursor left	:	One position to the left
Alt - cursor up	:	One position higher
Alt - cursor down	:	One position lower
Ctrl - cursor right	:	Several positions to the right
Ctrl - cursor left	:	Several positions to the left
Ctrl - cursor up	:	Several positions higher
Ctrl - cursor down	:	Several positions lower

The mouse keys are simulated on the keyboard as follows:

Alt - end	:	Depress lefthand mouse key
Alt - scroll down	:	Release lefthand mouse key
Alt - pos1	:	Depress righthand mouse key
Alt - scroll up	:	Release righthand mouse key

15.2.6 Slave configuration

After SIMOVIS has been started, you can define how many and which converters are connected to a USS bus (1...331 slaves). You can assign user names to each of the slaves. At first you can see a table with 31 lines. Each line corresponds to one of the possible slaves. You can define a slave by double clicking on the lefthand mouse key (or using cursor keys UP or DOWN and the RETURN key) on any number in the lefthand border; select the slave control version (FC, VC, SC, 6RA23), in the windows which open one after another, and if required, a technology software, and enter your user name for the particular slave. If you want to remove a slave, select menu item "0" as control version. You can recognize the slave number, control version and applicable the technology software and user names of the defined slaves in the table.

After you have changed the slave configuration, depress function key F10 SAVE. If you wish to start SIMOVIS without changing the slave configuration (the old configuration remains effective), depress F8 CONTINUE. Then, in the subsequent screen with warning information, depress F1 START. You will then see a screen, where the first defined slave checks back with its user name. Select the first SIMOVIS screen for the actual basic converter software using F1 BASIC CONV., and select the first screen of the actual technology software (if available) using F7 TECHN.SW.

To select another slave, click in the numerical field in the screen header next to the text CONV.ADR (converter address). A selection menu then opens for the defined slaves with their user names.

Restriction regarding the slave configuration:

Converters of one type must always have the same software release.

The SIMOVIS for 6RA24 (SIMOVIS version 1.0x) cannot run in the same catalog, and must be installed in its own directory.

15.3 Operator control

All SIMOVIS screens have a common screen structure. The screen is subdivided into the header-, footer and working areas.

The header area remains the same for all screens, and contains the following information:

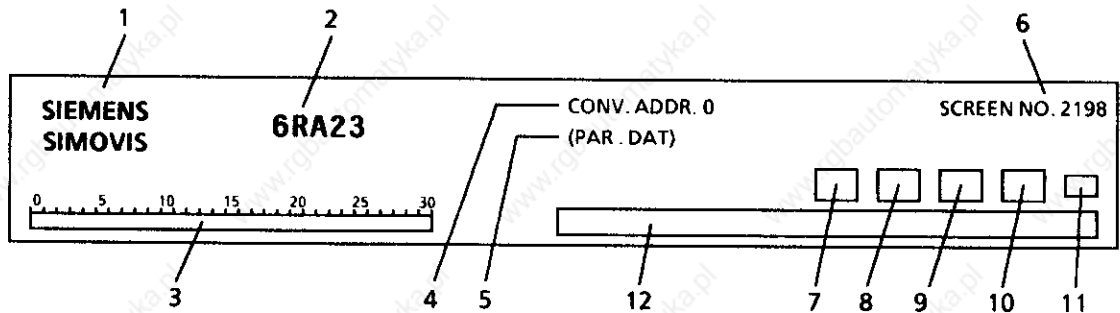

- 1 SIEMENS logo
- 2 6RA23 product logo
- 3 Bars, which indicate the status of all of the drive converters connected to the bus (up to 31). The following definitions are valid:

Dark blue	drive converter not logged-on
Grey, flashing	drive converter logged-on but presently no connection
Green	connection established
Red	connection established, converter in a fault condition
Yellow	connection established, alarm present
- 4 Converter address, to which the operating range is referred.
- 5 Name of the data file, which is being executed offline. This line always remains empty in online operation.
- 6 Mask number
- 7 Box to display an existing fault (read, flashing)
- 8 Box to display an existing alarm (yellow, flashing)
- 9 Not used for 6RA23 converters
- 10 Box to display a communications error (yellow, flashing)
- 11 Symbol to display whether write commands are only executed in the RAM, ("R"), or are permanently stored in the EEPROM ("E").
- 12 Window for message output.

The footer area shows the currently assigned function keys. The function can be executed by depressing the function key or by clicking on the appropriate field with the mouse.

- F1 calls-up a help screen associated with the current display
- F2 displays the last 10 internal SIMOVIS messages
- F11 generally branches into the previous screen
- F12 branches back to the main menu

Exception:

The function keys cannot be controlled from the mouse if the file window is opened for upload or download file (screen number 3999, parameter upread/download).

The controller structures and parameter values are displayed in the **working field** and can be changed by the user using mouse and keyboard.

The following display elements respond to a mouse click (lefthand mouse key):

- red blocks with white arrow (generally to select a field to enter parameter values),
- texts with a turquoise background (generally to send a specific parameter value),
- (function) blocks, with a turquoise border (generally to change into a sub-mask),
- the footer area with the description of the function keys (as for function key),
- the number after CON.ADR in the header, to enter the converter to be addressed and
- the number after PA.SET in the header to enter the parameter set to displayed.

By clicking with the righthand mouse key on

- the box, with black background, which shows parameter values or
- the red arrow blocks, which permit parameters to be changed,

a small pop-up window appears, in which the user can store comments to the appropriate parameter. The parameter value range appears as standard.

The following actions are possible using the keyboard:

- using the function keys, the display change, described in the footer area, is executed.
- the parameter value is entered in the pop-up edit windows using the numerical keys and point (as decimal point). The value to the left of the cursor is sent using <RETURN>.
- in the "USS short protocol" mask (2394), "USS long protocol" (2393) and "read/send any parameter" (2397), there are "entry fields" which can be cyclically selected using <TAB> or directly by clicking on them with the mouse and then the appropriate value can be entered.
- for some parameters, after the arrow icon has been clicked-on, a list appears with possible data input selection.
The cursor keys can be used to scan the individual steps, or it is possible to scroll down and up page by page using F3/F4. Once the correct entry has been found and marked, it is sent to the 6RA23 converter with F8 (!) (<RETURN> acts just like <CURSOR DOWNWARDS>).
- the function key functions in the UPREAD/DOWNLOAD masks can only be selected via the keyboard.

15.3.1 Special masks

UPREAD/DOWNLOAD mask (display No. 3999)

After depressing F3 (UPREAD) a mask is displayed with the existing parameter definition files. A parameter definition file defines those parameters, which are read-out using UPREAD, and stored in a parameter data file, by specifying the parameter number and index 0.

The INITALL.UPR file is supplied, which includes all parameters of software version 4.0.

If only upread parameters are required, a definition file (after entering the new file name) can be generated with F5 EDIT (the parameter number should be specified in the lefthand field, and index 0 in the righthand field). With F4 (UPREAD), the file name (of the parameter data file), under which the parameter is to be stored, is interrogated, and UPREAD started. The INITALL.UPR definition file includes (of the parameter data files), parameters, and reading takes several minutes at 19200 baud.

The thus received parameter data file has the extension .UPD and is located in Catalog SIMO __ P.

After the UPLOAD with F10 <RETURN> return to the UPREAD/DOWNLOAD basic display.

The DOWNLOAD mask is selected using F4 (DOWNLOAD). The following functions are available here:

F4 DOWNLOAD	The selected parameter data file is transferred to the SIMOREG drive converter.
F5 Edit	The actually selected parameter data file is displayed as list and can be edited.
F6 Copy	A parameter data file is copied into a file with new names.
F7 Delete	A parameter data file is deleted
F8 Diff.print	Two parameter data files are compared. Print-out (parameters which differ are designated by "*"); this function can take longer than 15 minutes)
F9 Print	A parameter data file is printed (far faster than function F8)

15.3.2 Toggling between online/offline

Normally, SIMOVIS is connected with one or several converters via the USS interface. Read and write operations are referred directly to the status in the selected drive converter (online operation).

For offline operation, reading and writing refers to a selectable file, in which a number of parameter numbers with associated parameter values is stored (similar to that situation in an actual converter). Such a file can be generated by:

- upreading a parameter value data set from a converter (online),
- writing parameter values into the working area of the SIMOVIS screens in offline operation,
- editing the file in SIMOVIS screen 3999 (read/write parameter sets: Via the main menu-parameter sets/factory setting). In this case, depress function key F4 DOWNLOAD. A window opens with an overview of all files which can be edited. By clicking on one of the file names or by entering a new name, you can define which file you wish to change or create. To edit, depress function F5 EDIT: The lefthand column of the window which opens contains the parameter numbers, the center column the parameter indices, the righthand column, the parameter values.

You can toggle between online and offline operation by entering the filename in screen 3999 in the screen header next to the text PAR.DAT, in the field provided; this file then supplies the parameter values (offline) to the SIMOVIS screens. The list of available names is obtained with F4 DOWNLOAD.

You can switch from offline- to online operation with F7 ONLINE, in screen 3999. The filename for offline operation, entered in the screen header, then disappears.

15.4 Overview of the available masks

Start mask (0001)

Main menu (2200)

Menu-prompted start-up (2300)

Check plug-in jumpers (2301)

Adapting the rated converter DC currents (2302)

Entering converter data (2303)

Entering rated motor data (2304)

Selection, speed actual value (2385)

 Analog tachometer (2384)

 Pulse encoder (2383)

 Additional parameters (2382)

 Operation without tachometer (closed-loop EMF controlled) (2380)

Field information (2377)

 Minireg F10 (2378)

 Minireg F33 (2379)

Set basic technological functions (2376)

Execute optimization runs (2305)

Final instructions (2306)

Load/store parameter sets (3999)

Equipment functions (2202)

Analog inputs (2350)

 Main setpoint (2351)

 Main actual value (2352)

 Analog select input (2353)

Binary inputs (2340)

Analog select outputs (2344)

 Current actual value (2345)

 Select output 1 (2346)

 Select output 2 (2347)

Binary select output (2342)

Open- and closed-loop control (2205)**Setpoint selection (2236)****Motorized potentiometer (2237)****Motorized potentiometer (2232)****Motorized potentiometer, torque direction I (2230)****Motorized potentiometer, torque direction II (2231)****Motorized potentiometer setpoint 0 (2239)****Inching (2234)****Crawl (2235)****Ramp-function generator (2240)****RFG changeover (2242)****Enable RFG (2243)****Stop RFG (2244)****Speed controller (2250)****Gearbox stage-, RFG changeover (2253)****Gearbox stage changeover (2254)****Fast stop (2259)****Current setpoint generation (2270)****Armature current controller setpoint, changeover M/I control (2272)****Torque limiting (2271)****Variable current limit (2273)****Speed-dependent and external current limit (2278)****Current controller (2280)****EMF controller (2285)****Pre-control (2286), (2288)****Z14/Z11 { selecting the available supplementary boards } (2310)****Operating mask (2395)****Faults/alarms (2392)****Display parameters (2391)****USS long protocol (2393)****USS short protocol (2394)****Free parameter change (2397)**

15.5 Troubleshooting

Problem: A connection is not established to the SIMOREG drive converter.

Remedy: Several causes are possible:

1. The connecting cable (refer to Section 10.18.1.1, Fig. 1) is faulty or is incorrectly connected:
Correct COM port at the PC, refer to point 2;
Correct interface connector at the 6RA23 (X501 for RS232 connection).
2. The interface used (COM1, COM2, ...) is not defined in the USS.INI file in the SIMO_D Catalog (operation = 0, ... for COM1, operation = 1, ... for COM2).
3. The baud rate settings in USS.INI and at the 6RA23 do not coincide, operation = 0, 9600, E, 8, 1, P, 1, 1 and P793 = xx5 (RS232).
4. The USS protocol definition is incorrect:
USS.INI: SLAVE = 0, 6RA23.00, 3, F, 3, 2, 8, 9, 101, 0C7E, 0000, 0000
6RA23: P97 = 1xx

USS.INI: SLAVE = 0, 6RA23.00, 3, F, 3, 8, 8, 9, 101, 0C7E, 0000, 0000
6RA23: P97 = 2xx
5. The PKW-length definition is incorrect:
USS.INI: SLAVE = 0, 6RA23.00, 3, F, 3, 3, 8, 9, 101, 0C7E, 0000, 0000
6. The plug-in jumpers XJ2, XJ6, XJ7, XJ8 in the 6RA23 (on the A1660 electronics board, directly above connector X501) are not in the position 1-2.

Problem: The hard disk is continuously accessed and the system is extremely slow.

Remedy: This can be improved by installing a hard disk cache (e.g. SMARTDRIVE) (SIMOVIS operates with several databases on the hard disk).

The cause can also be an incorrect setting of the USS.INI and/or P97.

16. Installation instructions for EMC-correct installation of Drives

Contents

	Page
16.1 EMC basics	16 / 2
16.1.1 What is EMC	16 / 2
16.1.2 Noise radiation and noise immunity	16 / 2
16.1.3 Maximum values	16 / 2
16.1.4 SIMOREG K converters in industrial applications	16 / 2
16.1.5 Non-grounded supplies	16 / 3
16.1.6 EMC planning	16 / 3
16.2 EMC-correct installation/mounting of converters (installation instructions)	16 / 4
16.2.1 General information	16 / 4
16.2.2 Rules for EMC-correct installation	16 / 4
16.2.3 Converter component arrangement	16 / 13
16.2.4 List of the recommended radio interference suppression filters	16 / 14
16.3 Information on line-side harmonics generated by converters in a fully-controlled three-phase bridge circuit configuration	16 / 15

NOTE

These Installation Instructions do not purport to handle or take into account all of the equipment details or versions or to cover every conceivable operating situation or application.

If you require more detailed information, or if special problems occur, which are not handled in enough detail in this document, please contact your local Siemens office.

The contents of these Installation Instructions are not part of an earlier or existing agreement or legal contract and neither do they change it. The actual purchase contract represents the complete liability of the ASI 1 Variable-Speed Drives Group of Siemens AG. The warranty conditions, specified in the contract between the two parties is the only warranty which will be accepted by the ASI 1 Variable-Speed Drives Group. The warranty conditions specified in the contract are neither expanded nor changed by the information provided in these Installation Instructions.

WARNING



These converters have components and parts at hazardous potentials, have dangerous rotating machine components (fans) and control rotating mechanical equipment (drives). Death, severe bodily injury or significant material damage could occur if the instructions in the associated Instruction Manuals are not followed.

Only qualified personnel who are knowledgeable about all of the safety information and instructions specified in the Instruction Manual as well as installation-, operating- and maintenance information may work on these converters. Perfect and safe operation of the converters assumes that they have been professionally transported, stored, installed and mounted as well as careful operator control and maintenance.

16.1 EMC basics

16.1.1 What is EMC

EMC stands for electromagnetic compatibility and defines the capability of a piece of equipment to operate satisfactorily in an electromagnetic environment without itself causing electromagnetic disturbances which would be unacceptable for other electrical equipment in this environment.

Thus, the electrical equipment should not mutually disturb each other.

16.1.2 Noise radiation and noise immunity

EMC is dependent on two characteristics of the equipment/units involved - the radiated noise and noise immunity. Electrical equipment can either be fault sources (transmitters) and/or noise receivers. Electromagnetic compatibility exists, if the fault sources do not negatively influence the function of the noise receivers. A piece of electrical equipment/unit can also be both a fault source and fault receiver at the same time. For example, the power section of a converter can be considered as noise source, and the control section (gating unit, etc.), as noise receiver.

16.1.3 Maximum values

The Product Standard E DIN IEC 22G/21/CDV is available as draft for electric drives. According to this product standard, all EMC measures are not necessarily required for industrial supply networks, and a solution should be defined, adapted to the actual environment. Thus, it may be more cost-effective to increase the noise immunity of a sensitive piece of equipment than implementing noise suppression measures for the converter. Thus, a solution is selected dependent on its cost-effectiveness.

The basic EN 50081 and EN 50082 Standards are valid until the Product Standard comes into force. These specify that EN 55011 must be maintained. These define max. values for noise radiation in industrial- and domestic environments. Cable-borne noise at the supply connection point is measured under standardized conditions as radio interference noise voltage, electromagnetically radiated noise as radio interference (radiated noise). The standard defines max. values „A1“ and „B1“, which are valid for the radio interference voltage in the range between 150 kHz and 30 MHz and for radio interference radiation between 30 MHz and 2 GHz. As SIMOREG K converters are used in industrial applications, in this case, limit value „A1“ is valid. To achieve value „A1“, SIMOREG K converters must be provided with external radio interference suppression filters.

The noise immunity defines the behavior of a piece of equipment subject to electromagnetic noise. For industrial applications, the EN50082-2 Standard defines the demands and evaluation criteria for the behavior of the unit/equipment. This standard is fulfilled by the converters listed in Section 2.3.

16.1.4 SIMOREG K converters in industrial applications

In an industrial environment, equipment must have a high level of noise immunity whereas lower demands are placed on noise radiation.

SIMOREG K converters are components of an electric drive system, along with contactors and switches etc. Professionally trained personnel must integrate them to form a complete drive system, which comprises, as a minimum, the converter itself, motor feeder cables and motor. Generally, commutating reactors and fuses are also required. Limiting (max.) values can only be maintained if these components are installed and mounted in the correct way. In order to limit the radiated noise according to limit value „A1“, in addition to the converter, a radio interference suppression filter and a commutating reactor are required. If SIMOREG K converters are not equipped with radio interference suppression filters, the radiated noise exceeds limit value „A1“, specified in EN55011.

If the drive is part of an overall system, initially it does not have to fulfill any requirements regarding radiated noise. However, the EMC Law specifies that the system as a whole must be electromagnetically compatible with its environment.

If all of the system control components (e.g. PLCs) have noise immunity for industrial environments, then it is not necessary that each drive maintains limit value „A1“ for itself.

16.1.5 Non-grounded supplies

Non-grounded supplies (IT-supplies) are used in several industrial sectors, in order to increase the availability of the plant. If a ground fault occurs, a fault current does not flow, and the plant can still produce. However, when a radio interference suppression filter is used, when a ground fault occurs, a fault current does flow, which can result in the drive being shutdown or even the radio interference suppression filter being destroyed. Thus, the Product Standard does not define limit values for these supplies. From a cost standpoint, if radio interference suppression is required, this should be realized at the grounded primary of the supply transformer.

16.1.6 EMC planning

If two units are not electromagnetically compatible, you can either reduce the noise radiated by the noise source, or increase the noise immunity of the noise receiver. Noise sources are generally power electronic units with a high current requirement. In order to reduce the radiated noise from these units, complex, costly filters are required. Noise receivers especially involve control units and sensors, including their evaluation circuitry. It is less complex and costly to increase the noise immunity of low-power equipment. Thus, in an industrial environment it is often more cost-effective to increase the noise immunity rather than reduce the radiated noise. For example, in order to maintain limit value Class A1 of EN 55011, the radio interference voltage at the supply connection point at 150 kHz and 500 kHz, may not exceed 79 dB(μ V) and between 500 kHz and 30 Mhz, 73 dB(μ V) (9 mV or 4.5 mV). In industrial environments, the EMC of the equipment used must be based on a well-balanced mixture of noise radiation (low level) and noise immunity.

The most favorably priced interference measure is to spatially isolate noise sources and noise receivers, assuming that it is already taken into account when designing the machine/plant. The first step is to define whether each unit is a potential noise source (noise radiator) or noise receiver. Noise sources are, for example, converters, contactors. Noise receivers are, for example, PLCs, transmitters and sensors.

The components must be spatially separated in the cabinet (noise sources and noise receivers), using metal partitions or by mounting the components in metal enclosures. A possible component layout configuration in a cabinet is illustrated in Fig. 1.

16.2 EMC-correct installation/mounting of converters (installation instructions)

16.2.1 General information

As drives can be operated in a wide range of differing environments, and as the electrical components used (controls, switched-mode power supplies etc.) can widely differ regarding noise immunity and noise radiation, any mounting/installation guideline can only be represent a practical compromise. Thus, deviations can be made from the EMC regulations, under the assumption that they are checked-out on a case-for-case basis.

In order to guarantee electromagnetic compatibility (EMC) in your cabinets in rugged electrical environments, and also fulfill the standards specified by the relevant legal bodies, the following EMC regulations must be observed when designing and manufacturing the drive cabinets.

Rules 1 to 10 are generally valid. Rules 11 to 15 are necessary, in order to fulfill the noise radiating standards.

16.2.2 Rules for EMC-correct installation

Rule 1

All of the metal cabinet components must be electrically connected with one another through the largest possible surface area (not paint on paint!). If required, use serrated washers. The cabinet door should be connected to the cabinet through grounding straps (top, center, bottom) which should be kept as short as possible.

Rule 2

Contactors, relays, solenoid valves, electro-magnetic operating hours counters etc. in the cabinet, and if required, in adjacent cabinets, should be provided with quenching elements, for example, RC elements, varistors, diodes etc. These devices must be connected directly at the coil.

Rule 3

Signal cables ¹⁾ should enter the cabinet, if possible, at only one level.

Rule 4

Non-shielded cables belonging to the same circuit (incoming and outgoing conductor) should be twisted, or the surface between the two conductors kept as low as possible in order to prevent unnecessary coupling effects.

Rule 5

Connect reserve conductors to the cabinet ground at both ends. This offers an additional shielding effect.

Rule 6

Unnecessary cable/conductor lengths should be avoided. Thus, coupling capacitances and inductances are kept low.

Rule 7

Crosstalk is kept low if cables are routed close to the cabinet ground. Thus, wiring shouldn't be routed freely in the cabinet, but as close as possible to the cabinet frame and mounting panels. This is also true for reserve cables.

Rule 8

Signal- and power cables should be routed separately from one another (to avoid noise being coupled-in!). A minimum 20 cm clearance should be maintained.

If it is not possible to spatially separate encoder- and motor cables, then the encoder cable must be laid either using a metal partition or in a metal pipe or duct. The partition or metal pipe must be grounded at several locations along this length.

Rule 9

The shields of digital signal cables must be connected to ground at both ends (source and destination) through the largest possible surface area. If there is poor potential bonding between the shield connections, to reduce the shield current, an additional potential bonding cable of at least 10 mm² must be connected in parallel to the shield. The shields can be connected to the cabinet frame at several positions (ground). The shields can also be connected to ground at several locations, even outside the cabinet.

Foil-type shields should be avoided if possible. They do not shield as well as braided shields; they are poorer by a factor at least 5.

Rule 10

The shields of analog signal cables can be connected to ground at both ends if potential bonding is good (through the largest possible surface area). Good potential bonding can be assumed, if all metal parts are well connected and all of the electronic components involved are supplied from one source.

The single-ended shield connection prevents low-frequency, capacitive noise from being coupled-in (e.g. 50 Hz hum). The shield should be connected in the cabinet, whereby the shield can also be connected up through a connecting wire.

Rule 11

Always locate the radio interference suppression filter close to the assumed noise source. The filter must be mounted through the largest possible surface area at the cabinet housing, mounting panel etc. The input and output cables must be spatially separated.

Rule 12

Radio interference suppression filters must be used in order to maintain limit value class A1. Additional loads must be connected in front of the filter (line supply side).

Ob ein zusätzliches Netzfilter installiert werden muß, ist abhängig von der verwendeten Steuerung und wie der restliche Schaltschrank verdrahtet ist.

Rule 13

A commutating reactor is required in the field circuit for controlled field supplies.

Rule 14

A commutating reactor is required in the converter armature circuit.

Rule 15

For SIMOREG drives, the motor cables can be unshielded. The line supply cable must be a minimum of 20 cm away from the motor cables (field, armature).

If required, use a metal partition.

Footnotes:

1) Signal cables are defined as:

Digital signal cables.:

Pulse encoder cables

Serial interfaces, e.g. PROFIBUS-DP

or analog signal cables.:

(e.g. ± 10 V setpoint cable)

2) Generally, all metallic conductive parts, which can be connected to a protective conductor, e.g. cabinet housing, motor frame, foundation grounder, etc., are considered as ground.

Cabinet design and shielding

The cabinet design illustrated in **Figure 1** is intended to make the user sensitive and aware of EMC-critical components and parts. The example does not claim to handle all possible cabinet components and their respective mounting possibilities.

Details, which influence the noise immunity/noise radiation of the cabinet and which aren't absolutely clear in the overview diagram, are described in **Figures 1a - 1d**.

Different shield connecting techniques with reference source information are illustrated in detail in **Figures 2a - 2d**.

Mounting radio interference suppression filters and commutating reactors:

Radio interference suppression filter and commutating reactor mounting for SIMOREG K drives is described in Section 16.2.3. The sequence when installing the reactor and filter must be maintained. The semiconductor protection fuses are selected according to the Instruction Manual of the converters.

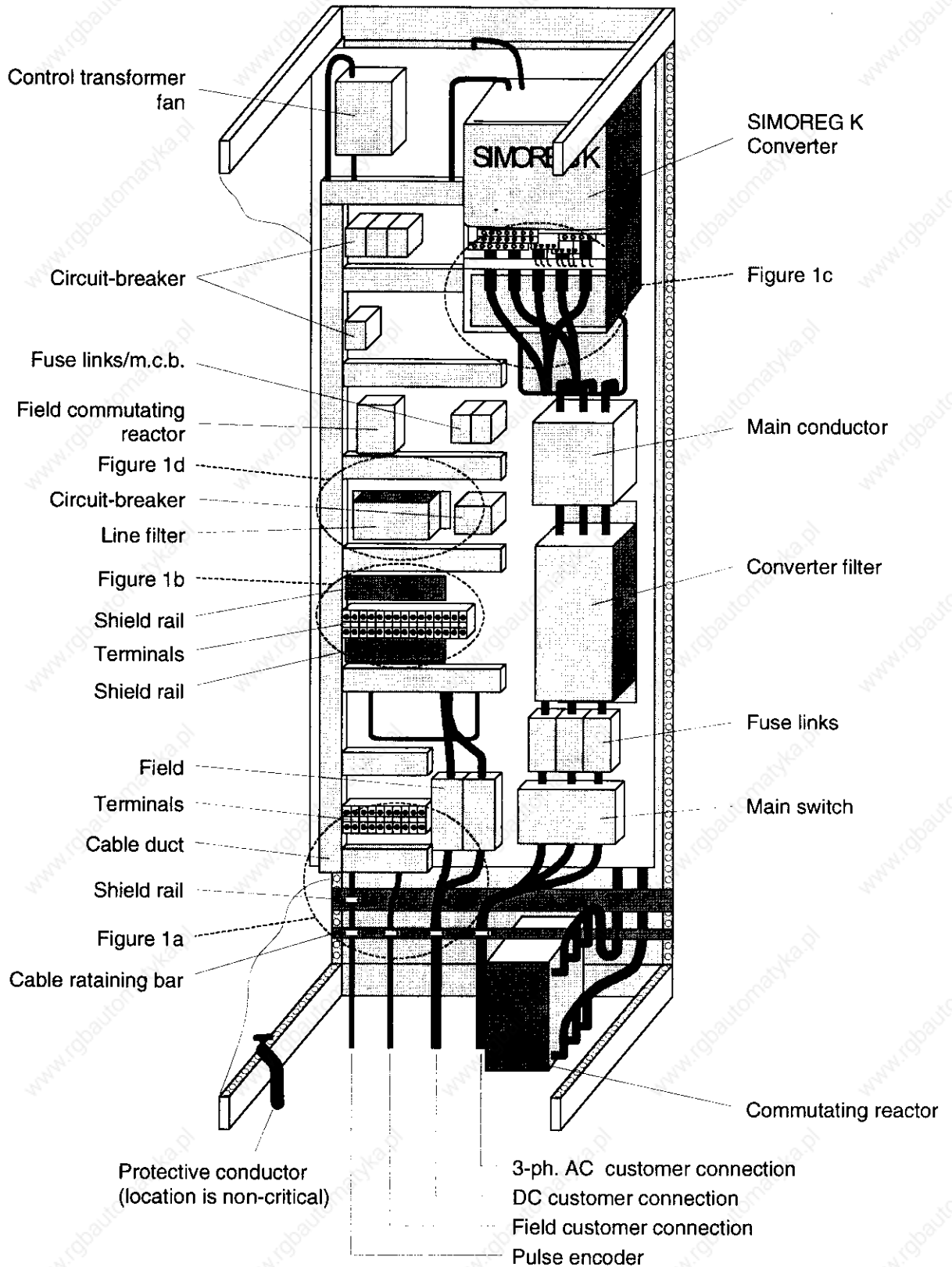

Figure 1: Example of a cabinet design with a SIMOREG K converter (with microprocessor)

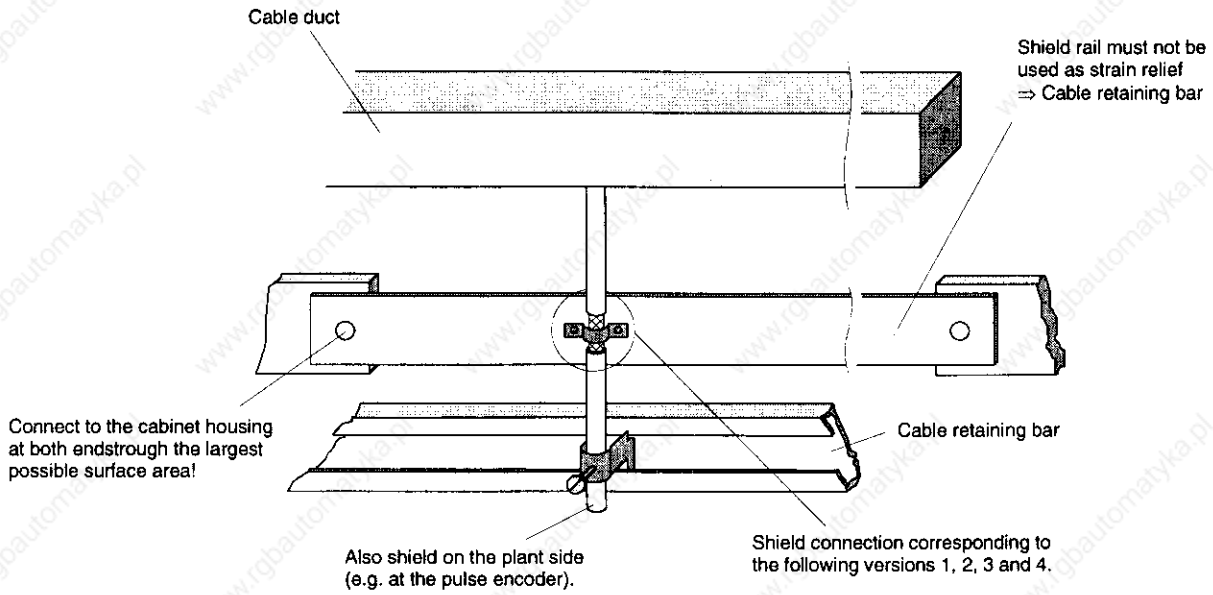

Figure 1a: Shielding where the cable enters the cabinet

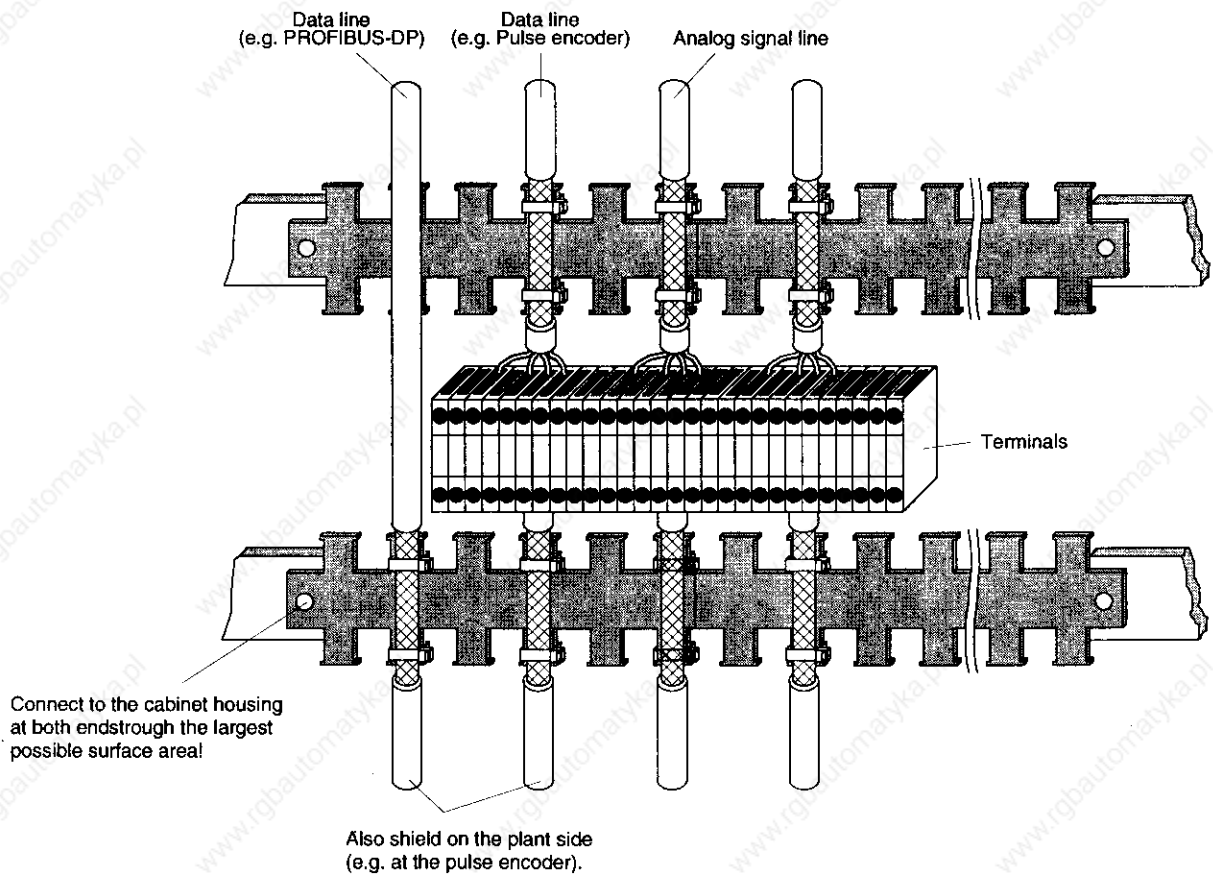

Figure 1b: Shielding in the cabinet

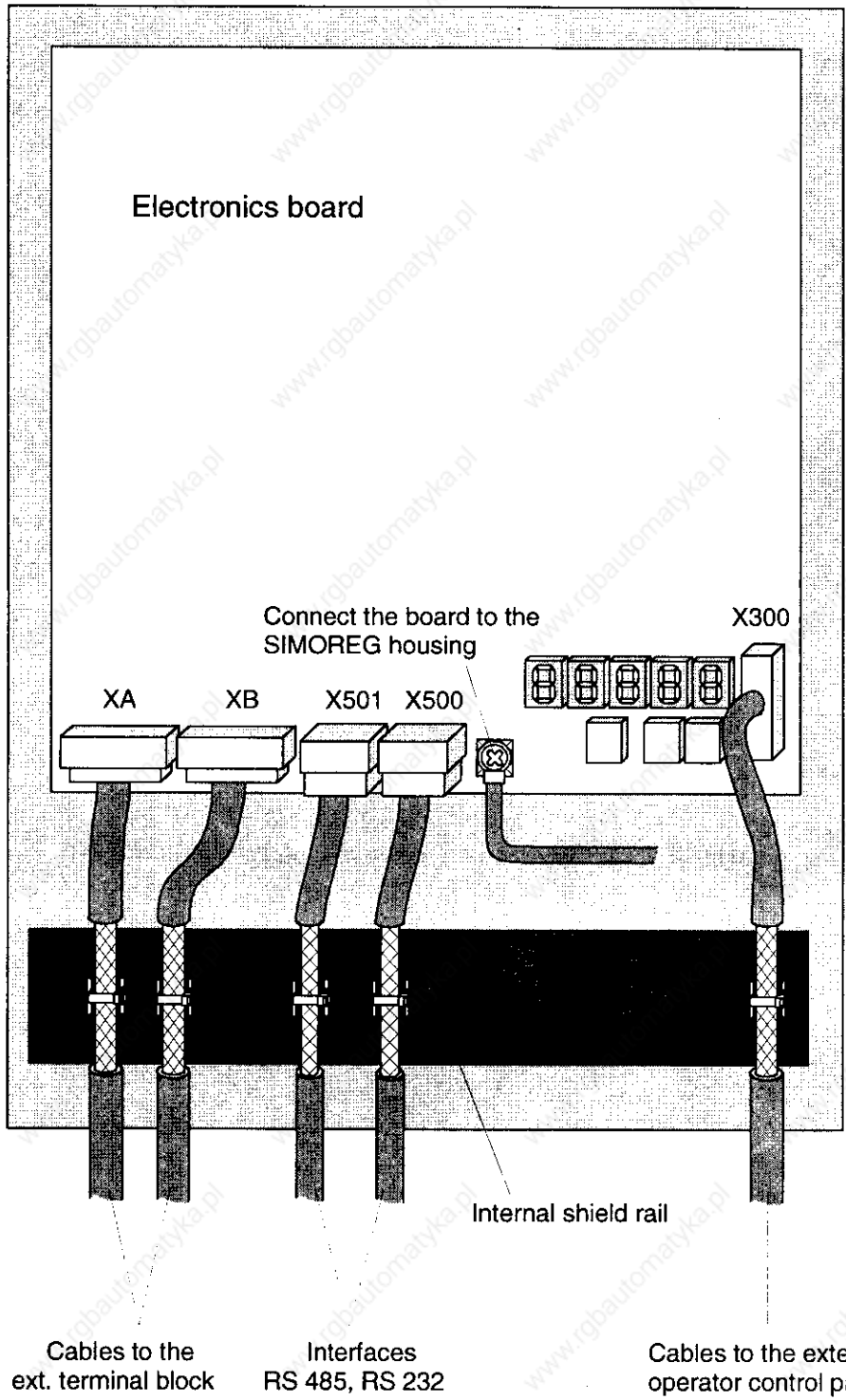

Figure 1c: Connecting the shields at the SIMOREG K

Connect the filter to the cabinet housing through the largest possible surface area!

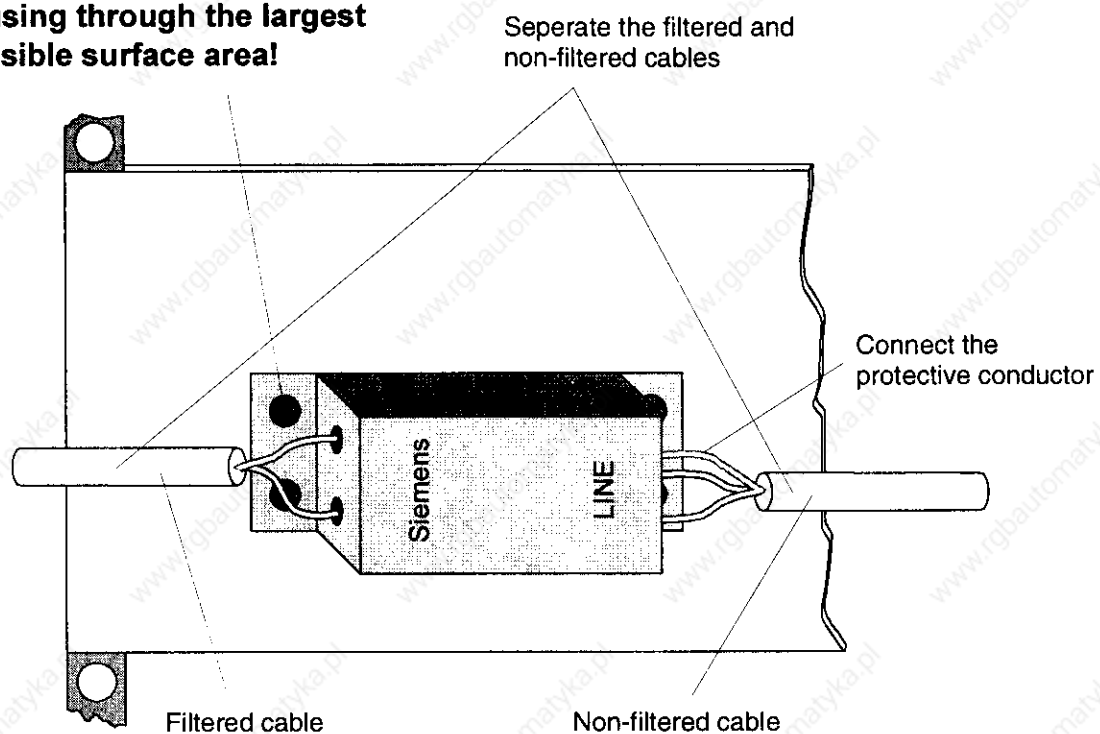
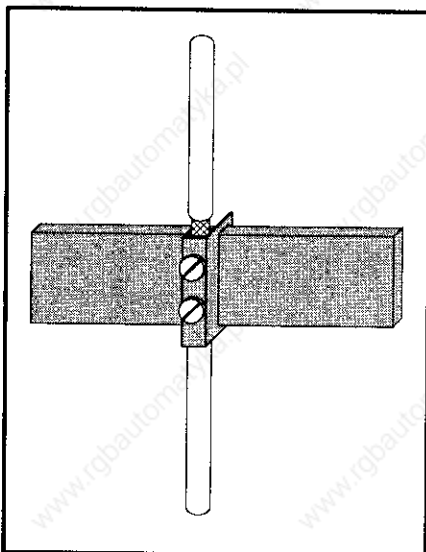

Figure 1d: Line filter for the SIMOREG K electronics power supply

Shield connection:

Version 1:



Version 2:

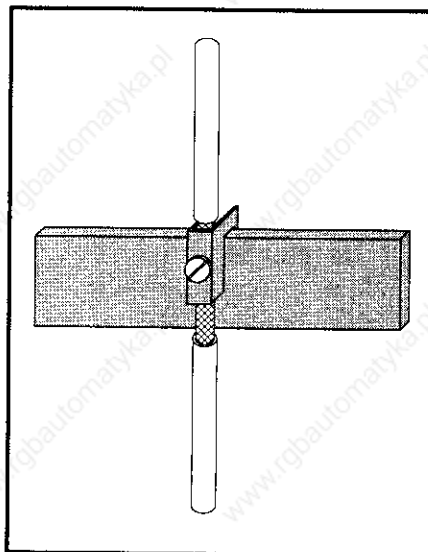

Figure 2a: Connecting terminal mounted on a copper busbar, max. cable / cable diameter 15 mm

Figure 2b: Terminal mounted on a copper busbar, max. cable / cable diameter 10 mm.

Caution!

The conductor could be damaged if the terminal screw is over-tightened

Note:

Terminals:
5 mm busbar thickness,
Order No. 8US1921-2AC00
10 mm busbar thickness,
Order No. 8US1921-2BC00

Note:

Terminals:
Order No. 8HS7104,
8HS7104, 8HS7174, 8HS7164

Version 3:

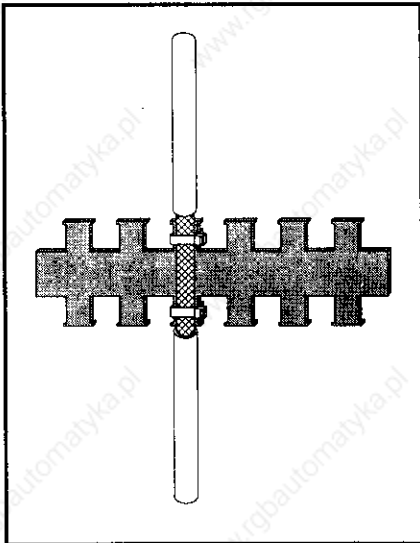

Version 4:

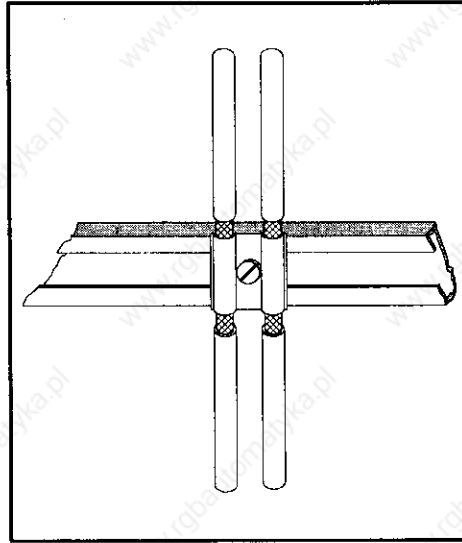

Figure 2c: Metalized tubing or cable ties on a bare metal serrated rail

Figure 2d: Clamp and metallic mating piece on a cable support rail.

Note:

Serrated rail:
Item No. J48028

Note:

Siemens 5VC55... cable clamps;
Various size mounting rails:
Item No. K48001 to 48005

Can be ordered from:

SIEMENS AG ANL A443 KA
Günther-Scharowsky-Str. 2
Betriebe Süd
91058 Erlangen

Can be ordered from:

SIEMENS AG ANL A443 KA
Günther-Scharowsky-Str. 2
Betriebe Süd
91058 Erlangen

16.2.3 Converter component arrangement

Reactor and filter arrangement

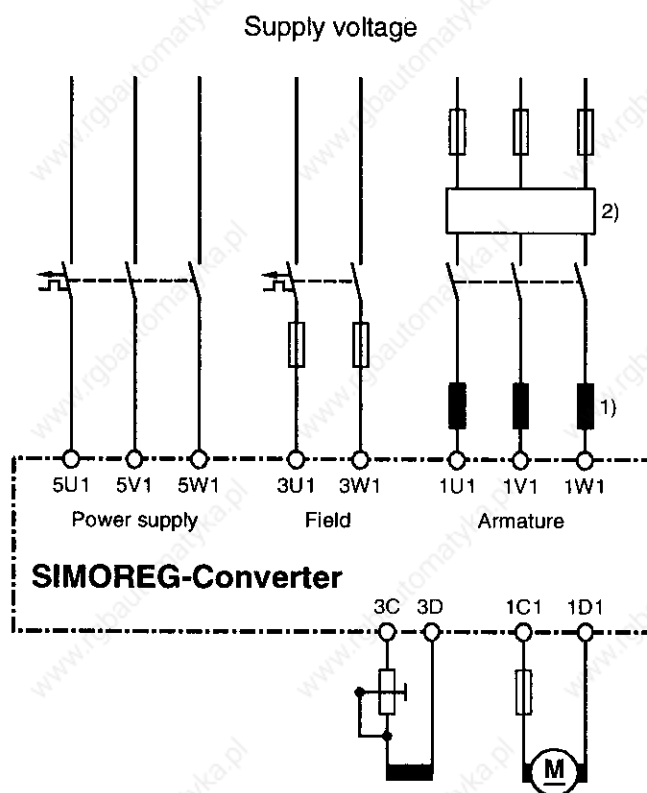

- 1) The commutating reactor in the armature circuit is dimensioned for the nominal motor armature current. The line supply current is the DC current $\times 0.82$.
- 2) The filter for the armature circuit is dimensioned for the nominal motor armature current. The line supply current is the DC current $\times 0.82$.

Note:

When filters are used, commutating reactors are always required at the converter input to decouple the snubber circuitry.

The commutating reactors are selected according to the information specified in Catalog DA93.1.

16.2.4 List of the recommended radio interference suppression filters

Rated current radio interference suppression filter (A)	Radio interference suppression filter Order No.	Terminal cross-section (mm ²)	Weight (kg)	Dimensions HxWxD (mm)
12	6SE7021-0ES87-0FB0	10*)	2,2	215x90x81
18	6SE7021-8ES87-0FB0	10*)	2,2	215x90x81
36	6SE7023-4ES87-0FB0	25	3,7	245x101x86
80	6SE7027-2ES87-0FB0	50	9,5	308x141x141
120	6SE7031-0ES87-0FA0	50	10	348x171x141
180	6SE7031-8ES87-0FA0	95	13	404x171x141
500	6SE7033-7ES87-0FA0	Connecting lug	49	590x305x154
1000	6SE7041-0ES87-0FA0	Connecting lug	90	840x465x204
1600	6SE7041-6ES87-0FA0	Connecting lug	130	870x465x204

*) The filters generate discharge currents. VDE 0160 specifies a protective conductor connection with 10 mm².

For converter units for 3-phase supplies, the line current (filter current) is equal to the DC current x 0.82.

For converters for two-phase supplies, two phases are connected to the three-phase filter. In this case, the line supply current is the same as the DC current.

Important technical data of the radio interference protection filter:

Rated supply voltage	3-ph 380-460 V (+/- 15%)
Rated frequency	50/60 Hz (+/- 6%)
Operating temperature	0° C to +40° C
Degree of protection	IP20 (EN60529) IP00 ≥ 500 A

Refer to the Instruction Manual for further technical data on the filters:

SIMOVERT Master Drives radio interference suppression filter, EMC filter,
Order No.: 6SE7087-6CX87-0FB0.

16.3 Information on line-side harmonics generated by converters in a fully-controlled three-phase bridge circuit configuration B6C and (B6)A(B6)C

Converter for the medium power range usually consists of fully-controlled three-phase bridge circuit configurations. An example of the harmonics generated by a typical system configuration for two firing angles ($\alpha = 20^\circ$ and $\alpha = 60^\circ$) is subsequently shown.

The values have been taken from an earlier publication, and more specifically from "Harmonics in the line-side current of six-pulse line-commutated converters" from H. Arremann and G. Möltgen, Siemens Forsch.- u. Entwickl.-Ber. Bd. 7 (1978) Nr. 2, © Springer-Verlag 1978.

Formulas and equations were specified with which the short-circuit rating S_K and the armature inductance L_a could be determined dependent on the specific operating data (line supply voltage (no-load voltage V_{V0}), line frequency f_N and DC current I_d); this would then be valid for the specified harmonic spectrum. A dedicated calculation is required if the actual system fault level and/or the actual armature inductance deviate from the calculated values.

The specified harmonic spectrum is obtained, if the values for the system fault level S_K at the converter supply point and armature inductance L_a of the motor, calculated using the following formulas, are the same as the actual plant values. The harmonics must be separately calculated if the values differ.

a.) $\alpha = 20^\circ$

Basic fundamental $g = 0,962$

b.) $\alpha = 60^\circ$

Basic fundamental $g = 0,953$

v	I_v/I_1	v	I_v/I_1
5	0,235	29	0,018
7	0,100	31	0,016
11	0,083	35	0,011
13	0,056	37	0,010
17	0,046	41	0,006
19	0,035	43	0,006
23	0,028	47	0,003
25	0,024	49	0,003

v	I_v/I_1	v	I_v/I_1
5	0,283	29	0,026
7	0,050	31	0,019
11	0,089	35	0,020
13	0,038	37	0,016
17	0,050	41	0,016
19	0,029	43	0,013
23	0,034	47	0,013
25	0,023	49	0,011

The basic fundamental current I_1 is calculated using the following formula as reference quantity

$$I_1 = g \times 0,817 \times I_d$$

with I_d DC current at the operating point being investigated

with g Harmonic content (refer above)

The harmonic currents calculated from the above tables, are **only** valid for

I.) System fault level S_K at the converter supply connection point

$$S_K = \frac{U_{V0}^2}{X_N} \quad (\text{VA})$$

with

$$X_N = X_K - X_D = 0,03536 \times \frac{U_{v0}}{I_d} - 2\pi f_N \times L_D \quad (\Omega)$$

and

U_{v0} No-load voltage at the converter supply connection point in V

I_d DC current in A at the operating point to be investigated

f_N Line frequency in Hz

L_D Inductance of the commutating reactor in H

II.) Armature inductance L_a

$$L_a = 0,0488 \times \frac{U_{v0}}{f_N \times I_d} \quad (\text{H})$$

A separate calculation is required if the actual system fault level S_K and/or the armature inductance L_a deviate from the values calculated using the above formula.

Example

A drive has the following data:

$$U_{v0} = 400 \text{ V}$$

$$I_d = 150 \text{ A}$$

$$f_N = 50 \text{ Hz}$$

$$L_D = 0,169 \text{ mH (4EU2421-7AA10 with } I_{L_N} = 125 \text{ A)}$$

With

$$X_N = 0,03536 \times \frac{400}{150} - 2\pi \times 50 \times 0,169 \times 10^{-3} = 0,0412 \Omega$$

provides the following system fault level at the converter connecting point

$$S_K = \frac{400^2}{0,0412} = 3,88 \text{ MVA}$$

and the following motor armature inductance which is required.

$$L_a = 0,0488 \times \frac{400}{50 \times 150} = 2,60 \text{ mH}$$

The harmonic currents I_v , which can be taken from the tables (with $I_1 = g \times 0,817 \times I_d$ for firing angles $\alpha = 20^\circ$ and $\alpha = 60^\circ$) are **only** valid for the calculated values S_K and L_a . A separate calculation is required if the values differ.

When dimensioning/designing filters and compensation circuits with reactors, the thus determined harmonic values can only be used if the calculated values for S_K and L_a are the same as the actual drive values. For all other case, a separate calculation must be made (this is especially true when using compensated motors, as these motors have a very low armature inductance).

The following versions have appeared so far:

Version	Internal Part number
01	C98130-A1205-A1-01-7647
02	C98130-A1205-A1-02-7647

Version **02** consists of the following chapters

Chapter	Pages	Date of Edition
0 Contents	10	11.94
1 Safety information	2	11.94
2 Type spectrum	4	11.94
3 Description	8	11.94
4 Unpacking	2	11.94
5 Installation	12	11.94
6 Connecting-up	26	11.94
7 Start-up	24	11.94
8 Operation	14	11.94
9 Parameter list	40	11.94
10 Functions	56	11.94
11 Maintenance	2	11.94
12 Service	2	11.94
13 Spare parts	2	11.94
14 Appendix	2	11.94
15 SIMOVIS	10	11.94
16 Installation instructions for EMC-correct installation of Drives	16	03.96

