

PowerXL™

DA1

Variable Frequency Drives



EATON

Powering Business Worldwide

All brand and product names are trademarks or registered trademarks of the owner concerned.

Emergency On Call Service

Please call your local representative:

<http://www.eaton.com/moeller/aftersales>

or

Hotline of the After Sales Service:

+49 (0) 180 5 223822 (de, en)

AfterSalesEGBonn@eaton.com

Original Operating Instructions

The German-language edition of this document is the original operating manual.

Translation of the original operating manual

All editions of this document other than those in German language are translations of the original German manual.

1st published 2012, edition date 10/12

© 2012 by Eaton Industries GmbH, 53105 Bonn

Production: René Wiegand

Translation: globaldocs GmbH

All rights reserved, including those of the translation.

No part of this manual may be reproduced in any form (printed, photocopy, microfilm or any other process) or processed, duplicated or distributed by means of electronic systems without written permission of Eaton Industries GmbH, Bonn.

Subject to alteration without notice.



Danger! **Dangerous electrical voltage!**

Before commencing the installation

- Disconnect the power supply of the device.
- Ensure that devices cannot be accidentally restarted.
- Verify isolation from the supply.
- Earth and short circuit the device.
- Cover or enclose any adjacent live components.
- Follow the engineering instructions (AWA/IL) for the device concerned.
- Only suitably qualified personnel in accordance with EN 50110-1/-2 (VDE 0105 Part 100) may work on this device/system.
- Before installation and before touching the device ensure that you are free of electrostatic charge.
- The functional earth (FE, PES) must be connected to the protective earth (PE) or the potential equalisation. The system installer is responsible for implementing this connection.
- Connecting cables and signal lines should be installed so that inductive or capacitive interference does not impair the automation functions.
- Install automation devices and related operating elements in such a way that they are well protected against unintentional operation.
- Suitable safety hardware and software measures should be implemented for the I/O interface so that an open circuit on the signal side does not result in undefined states in the automation devices.
- Ensure a reliable electrical isolation of the extra-low voltage of the 24 V supply. Only use power supply units complying with IEC 60364-4-41 (VDE 0100 Part 410) or HD384.4.41 S2.
- Deviations of the mains voltage from the rated value must not exceed the tolerance limits given in the specifications, otherwise this may cause malfunction and dangerous operation.
- Emergency stop devices complying with IEC/EN 60204-1 must be effective in all operating modes of the automation devices. Unlatching the emergency-stop devices must not cause a restart.
- Devices that are designed for mounting in housings or control cabinets must only be operated and controlled after they have been installed and with the housing closed. Desktop or portable units must only be operated and controlled in enclosed housings.
- Measures should be taken to ensure the proper restart of programs interrupted after a voltage dip or failure. This should not cause dangerous operating states even for a short time. If necessary, emergency-stop devices should be implemented.
- Wherever faults in the automation system may cause injury or material damage, external measures must be implemented to ensure a safe operating state in the event of a fault or malfunction (for example, by means of separate limit switches, mechanical interlocks etc.).
- Depending on their degree of protection, frequency inverters may contain live bright metal parts, moving or rotating components or hot surfaces during and immediately after operation.
- Removal of the required covers, improper installation or incorrect operation of motor or frequency inverter may cause the failure of the device and may lead to serious injury or damage.
- The applicable national accident prevention and safety regulations apply to all work carried on live frequency inverters.
- The electrical installation must be carried out in accordance with the relevant regulations (e. g. with regard to cable cross sections, fuses, PE).
- Transport, installation, commissioning and maintenance work must be carried out only by qualified personnel (IEC 60364, HD 384 and national occupational safety regulations).
- Installations containing frequency inverters must be provided with additional monitoring and protective devices in accordance with the applicable safety regulations. Modifications to the frequency inverters using the operating software are permitted.
- All covers and doors must be kept closed during operation.
- To reduce the hazards for people or equipment, the user must include in the machine design measures that restrict the consequences of a malfunction or failure of the drive (increased motor speed or sudden standstill of motor). These measures include:
 - Other independent devices for monitoring safety-related variables (speed, travel, end positions etc.).
 - Electrical or non-electrical system-wide measures (electrical or mechanical interlocks).
 - Never touch live parts or cable connections of the frequency inverter after it has been disconnected from the power supply. Due to the charge in the capacitors, these parts may still be live after disconnection. Fit appropriate warning signs.

Table of contents

0	About this Manual	5
0.1	Target group.....	5
0.2	Writing conventions	5
0.3	Abbreviations	6
0.4	Mains supply voltages.....	7
0.5	Units.....	7
1	DA1 device series	9
1.1	Introduction	9
1.2	System overview	10
1.3	Checking the Delivery	11
1.4	Rated data	13
1.4.1	Rating data on the nameplate	13
1.4.2	Key to part numbers.....	14
1.4.3	General rated operational data	16
1.4.4	Features	19
1.5	DA1 layout.....	21
1.6	Features	22
1.7	Selection criteria.....	24
1.8	Proper use.....	25
1.9	Maintenance and inspection	26
1.10	Storage.....	26
1.11	Charging the internal DC link capacitors	27
1.12	Service and warranty.....	27
2	Engineering.....	29
2.1	Introduction	29
2.2	Electrical power network	30
2.2.1	Mains connection and configuration	30
2.2.2	Mains voltage and frequency	31
2.2.3	Voltage balance	31
2.2.4	Total Harmonic Distortion (THD)	32
2.2.5	Idle power compensation devices	33
2.2.6	Mains chokes	33
2.3	Safety and switching.....	34
2.3.1	Fuses and cable cross-sections	34
2.3.2	Residual current device.....	35
2.3.3	Mains contactors.....	36
2.4	EMC compliance	36

2.5	Motor and Application.....	38
2.5.1	Motor selection.....	38
2.5.2	Parallel connection of motors.....	38
2.5.3	Circuit types with three-phase motors.....	40
2.5.4	87-Hz Characteristic curve.....	40
2.5.5	Bypass operation.....	42
2.5.6	Connecting EX motors.....	43
2.5.7	Sinusoidal filter.....	43
3	Installation.....	45
3.1	Introduction.....	45
3.2	Mounting.....	45
3.2.1	Mounting position.....	46
3.2.2	Cooling measures.....	46
3.2.3	Control panel installation.....	49
3.2.4	Fixing.....	50
3.3	EMC installation.....	53
3.3.1	EMC measures in the control panel.....	53
3.3.2	Earthing.....	54
3.3.3	EMC screw.....	55
3.3.4	VAR screw.....	56
3.3.5	Screen earth kit.....	56
3.4	Electrical Installation.....	58
3.4.1	Power section connections.....	59
3.4.2	Connection on control section.....	64
3.4.3	Block diagrams.....	72
3.4.4	Insulation test.....	74
4	Operation.....	75
4.1	Checklist for commissioning.....	75
4.2	Hazard warnings for operation.....	76
4.3	Commissioning with control signal terminals (default settings) ..	77
5	Error messages.....	81
5.1	Introduction.....	81
5.1.1	Error messages.....	81
5.1.2	Acknowledge fault (Reset).....	81
5.1.3	Error list.....	83

6	Parameters.....	87
6.1	Operating unit	129
6.1.1	Display unit.....	130
6.1.2	Menu Navigation	130
6.1.3	Setting parameters.....	130
6.1.4	Parameter selection	131
6.2	Digital and analog inputs	132
6.2.1	Digital Input (DI)	135
6.2.2	Analog Input (AI).....	136
6.2.3	Digital / analog outputs.....	144
6.2.4	Drives control	148
6.2.5	Second acceleration and deceleration time	149
6.2.6	Frequency jump	150
6.2.7	Start Function.....	151
6.2.8	Motor	153
6.2.9	Fixed frequency setpoint values	155
6.2.10	V/f characteristic curve.....	157
6.2.11	Braking	162
6.3	Operational data indicator	168
6.4	Setpoint input (REF)	169
7	Serial interface (Modbus RTU).....	171
7.1	General.....	171
7.1.1	Communication	171
7.1.2	Serial interface	172
7.2	Modbus parameters.....	173
7.3	Operating mode Modbus RTU	174
7.3.1	Structure of the master request.....	175
7.3.2	Structure of the slave response	176
7.3.3	Modbus: Register mapping.....	177
7.3.4	Explanation of function code.....	185
8	CANopen.....	187
8.1	Data Types	187
8.2	System overview	188
8.2.1	Bus termination resistors	190
8.2.2	Baud rate.....	190
8.2.3	Set CANopen station address.....	190
8.2.4	Parameters that need to be configured	190
8.3	Object list.....	191
8.3.1	EDS file	191
8.3.2	Communication-specific objects	192
8.3.3	Server SDO Parameter.....	193
8.3.4	Manufacturer-specific objects.....	195
8.3.5	Control word (Index 2000 _{hex})	198
8.4	Error messages	200

9	Appendix.....	203
9.1	Special technical data.....	203
9.1.1	DA1-12 device series.....	204
9.1.2	DA1-32 device series.....	205
9.1.3	DA1-32 device series.....	206
9.1.4	DA1-34 device series.....	207
9.2	Dimensions and frame size.....	209
9.3	PC interface card.....	211
9.3.1	DX-COM-STICK.....	211
9.3.2	drivesConnect.....	214
9.3.3	Cables and fuses.....	215
9.4	Mains contactors.....	219
	Alphabetical index.....	221

0 About this Manual

This manual contains special information required for the correct selection and connection of a DA1 variable frequency drive and its configuration to your specific requirements using the parameters. All information applies to the specified hardware and software versions. The manual describes all sizes of the DA1 device series. The differences and special characteristics of each rating level and size are listed accordingly.

0.1 Target group

The content of MN04020005Z-EN manual is written for engineers and electricians. A specialist knowledge of electrical engineering and fundamental technical principles is needed for commissioning.

We assume that you have a good knowledge of engineering fundamentals and that you are familiar with handling electrical systems and machines, as well as with reading technical drawings.

0.2 Writing conventions

Symbols used in this manual have the following meanings:

► Indicates instructions to be followed.



Indicates useful tips.

NOTICE

Warns about the possibility of material damage.



CAUTION

Warns of the possibility of hazardous situations that may possibly cause slight injury.



DANGER

Warns of hazardous situations that result in serious injury or death.

For greater clarity, the name of the current chapter and the name of the current section are shown in the page header.

0 About this Manual

0.3 Abbreviations



In order to make it easier to understand some of the images included in this manual, the housing of the variable frequency drive, as well as other safety-relevant parts, have been left out. However, it is important to note that the variable frequency drive must always be operated with its housing placed properly, as well as with all required safety-relevant parts.



All the specifications in this manual refer to the hardware and software versions documented in it.



More information on the devices described here can be found on the Internet under:

<http://www.eaton.com/moeller> → **Support**

0.3 Abbreviations

The following abbreviations are used in this manual.

EMC	Electromagnetic compatibility
FE	Functional earth
FS	Frame Size
FWD	Forward run (clockwise rotating field)
GND	Ground (0-V-potential)
IGBT	Insulated gate bipolar transistor
LCD	Liquid Crystal Display
PDS	Power Drive System (magnet system)
PE	Protective earth \oplus
PES	EMC connection to PE for screened lines
PNU	Parameter number
REV	Reverse run (anticlockwise rotation field active)
UL	Underwriters Laboratories
DS	Default settings

0.4 Mains supply voltages

The rated operating voltages stated in the following table are based on the standard values for networks with a grounded star point.

In ring networks (as found in Europe) the rated operating voltage at the transfer point of the power supply companies is the same as the value in the consumer networks (e.g. 230 V, 400 V).

In star networks (as found in North America), the rated operating voltage at the transfer point of the utility companies is higher than in the consumer network. Example: 120 V → 115 V, 240 V → 230 V, 480 V → 460 V.

The DA1 variable frequency drive's wide tolerance range takes into account a permissible voltage drop of 10 % (i.e. $U_{LN} - 10\%$) while, in the 400-V category, it takes into account the North American mains voltage of 480 V + 10 % (60 Hz).

The permissible power supplies for the DA1 series are listed in the Technical Data section in the appendix.

The rated mains voltage operational data is always based on mains frequencies of 50/60 Hz within a range of 48 to 62 Hz.

0.5 Units

Every physical dimension included in this manual uses international metric system units, otherwise known as SI (Système International d'Unités) units. For the purpose of the equipment's UL certification, some of these dimensions are accompanied by their equivalents in imperial units.

Table 1: Unit conversion examples

designation	US-American value	US-American designation	SI value	Conversion value
Length	1 in (")	inch	25.4 mm	0.0394
Power	1 HP = 1.014 PS	horsepower	0.7457 kW	1.341
Torque	1 lbf in	pound-force inches	0.113 Nm	8.851
Temperature	1 °F (T _F)	Fahrenheit	-17.222 °C (T _C)	T _F = T _C × 9/5 + 32
Speed	1 rpm	Revolutions per minute	1 min ⁻¹	1
Weight	1 lb	pound	0.4536 kg	2.205

0 About this Manual

0.5 Units

1 DA1 device series

1.1 Introduction

DA1 series variable frequency drives are suited to applications involving the frequency control of motors within an output range of 0.75 kW (at 230 V) to 160 kW (at 400 V).

DA1 series devices feature a compact and rugged design and are available in seven sizes (FS2, ... , FS8), as well as with protection types IP20, IP40, IP55 and IP66. For protection type IP66, there is also a model with a mains switch and controls for local control available.

Due to their ease of use and handling, the innovative technology behind them, and a high level of reliability, DA1 variable frequency drives are particularly suitable for use in general applications. In addition, an integrated radio interference suppression filter and a flexible interface ensure that the inverters meet a number of important needs in the machine building industry when it comes to the optimization of production and manufacturing processes.

The computer-supported parameter configuration software ensures data integrity and reduces the time required for commissioning and maintenance.

In addition, the comprehensive accessories available increase the inverters' flexibility in all areas of application.

1.2 System overview

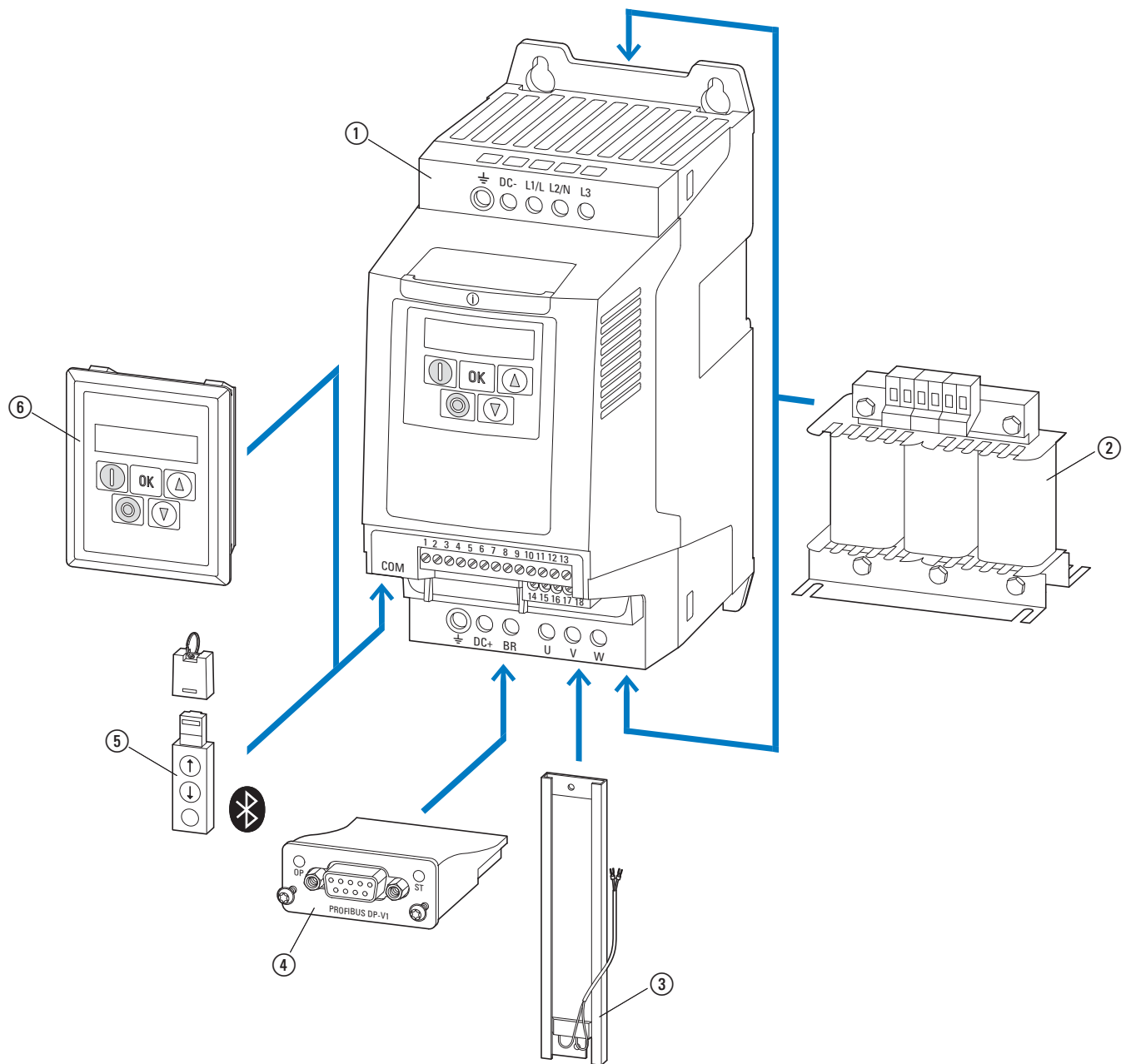

Figure 1: DA1 variable frequency drives system overview

- ① DA1-... variable frequency drives
- ② DX-LN-... main chokes, DX-LM3-... motor reactors, DX-SIN3-... sinusoidal filters
- ③ DX-BR-... braking resistance
- ④ Fieldbus connection and expansion group
- ⑤ DX-COM-STICK communication module and accessories (e. g. DX-CBL-... connection cable)
- ⑥ DE-KEY-... keypad (external)

1.3 Checking the Delivery



Before opening the package, please check the label on it to make sure that you received the correct variable frequency drive.

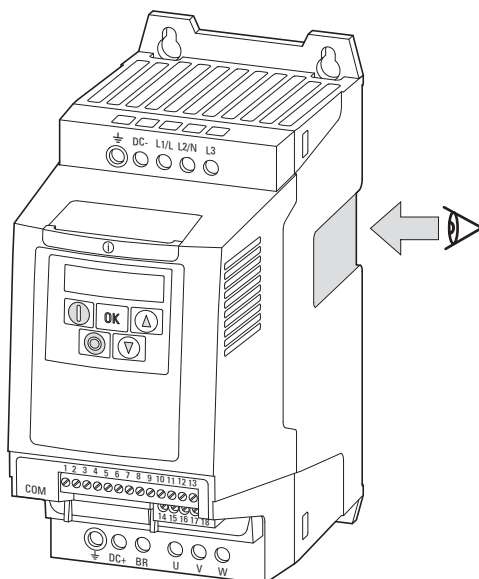

Figure 2: Location of nameplate on DA1 variable frequency drive

The DA1 series variable frequency drives are carefully packaged and prepared for delivery. The devices should be shipped only in their original packaging with suitable transportation materials. Please take note of the labels and instructions on the packaging, as well as of those meant for the unpacked device.

Open the packaging with suitable tools and inspect the contents immediately after delivery to ensure that they are complete and undamaged.

1 DA1 device series

1.3 Checking the Delivery

The packaging must contain the following parts:

- DA1 series variable frequency drive,
- an instructional leaflet
 - IL04020010Z for devices with FS2 and FS3 size with IP20 protection type,
 - IL04020011Z for devices with FS4 to FS7 sizes with IP55 protection type,
 - IL04020012Z for panel-version variable frequency drives of size FS8
- A data carrier (CD-ROM) containing documentation for DA1 series variable frequency drives.

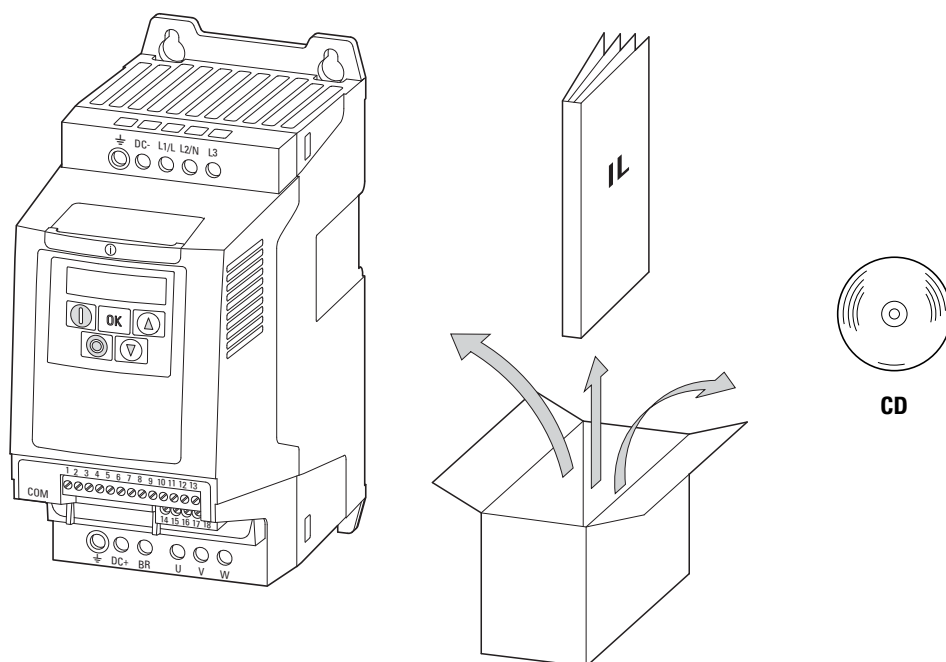

Figure 3: Equipment supplied with DA1 variable frequency drive

1.4 Rated data

Voltage categories

DA1 variable frequency drives are divided into following voltage categories:

- 230 V: DA1-1**2**..., DA1-3**2**...
- 400 V: DA1-3**4**...

1.4.1 Rating data on the nameplate

The device-specific rated operational data for the DA1 variable frequency drive is listed on the nameplate on the right side of the device.

The inscription of the nameplate has the following meaning (example):

Inscription	Meaning
DA1-344D1FB-A20N	Part no.: DA1 = DA1 series variable frequency drive 3 = Three-phase mains connection / three-phase motor connection 4 = 400 V mains voltage category 4D1 = 4.1 A rated operational current (4-decimal-1, output current) F = Integrated radio interference suppression filter B = Integrated brake chopper A = LED display (7-segment text display) 20 = IP20 protection type N = Standard basic device
Input	Power connection rating: Three-phase AC voltage (U_e 3~ AC), 380 - 480 V voltage, 50/60 Hz frequency, input phase current (4.3 A).
Output	Load side (motor) rating: Three-phase AC voltage (0 - U_e), output phase current (4.1 A), output frequency (0 - 500 Hz)
Power	Assigned motor output: 1.5 kW at 400 V/2 HP at 460 V for a four-pole, internally cooled or surface-cooled three-phase motor (1500 rpm at 50 Hz/1800 rpm at 60 Hz)
S/N	Serial number
	Variable frequency drive is an electrical apparatus. Read the manual (in this case MN04020005Z-EN) before making any electrical connections and commissioning.
IP20/Open type	Protection type of the housing: IP20, UL (cUL) Open type
25072012	Manufacturing date: 07-25-2012

1 DA1 device series

1.4 Rated data

1.4.2 Key to part numbers

The catalog no. or part no. for the DA1 series of variable frequency drives is made up of four sections.

Series – Power section – Model – Version

The following figure shows it in greater detail:

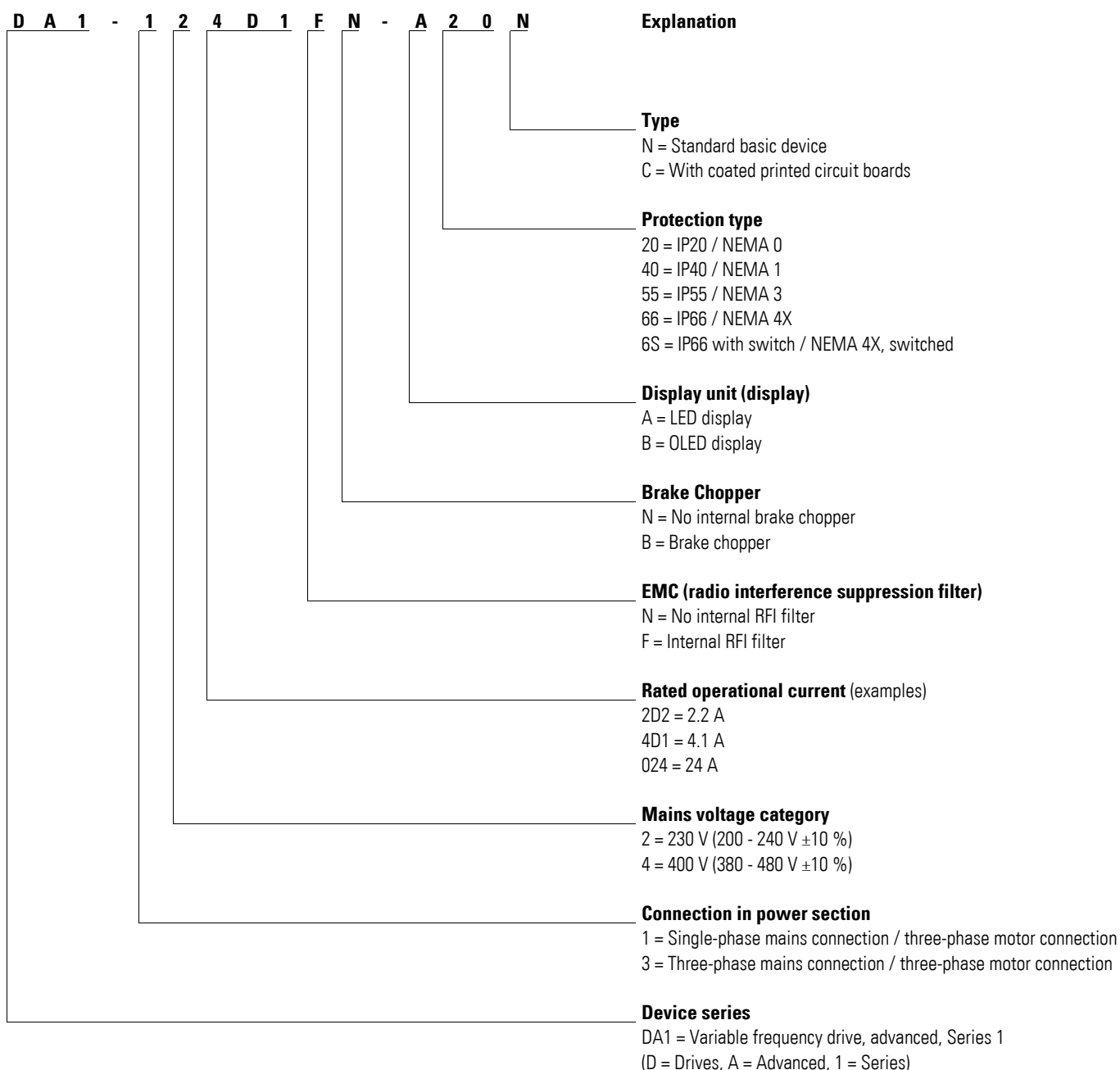

Figure 4: Key to part numbers of the DA1 variable frequency drives

Catalog number examples

Inscription	Meaning
DA1-124D3NN-A20C	DA1 = DA1 series variable frequency drive 1 = Single-phase power supply 2 = Mains voltage category: 230 V (200 V - 240 V ±10 %) 4D3 = Rated operational current: 4.3 A N = No internal radio interference suppression filter N = No internal brake chopper A = LED display 20 = IP20 protection type C = Coated printed circuit boards
DA1-122D3FN-A20N	DA1 = DA1 series variable frequency drive 1 = Single-phase power supply 2 = Mains voltage category: 230 V (200 V - 240 V ±10 %) 2D3 = Rated operational current: 2.3 A N = Internal radio interference suppression filter N = No internal brake chopper A = LED display 20 = IP20 protection type N = Not coated printed circuit boards
DA1-327D0FB-A20N	DA1 = DA1 series variable frequency drive 3 = Three-phase mains supply voltage 2 = Mains voltage category: 230 V (200 V - 240 V ±10 %) 7D0 = Rated operational current: 7.0 A N = Internal radio interference suppression filter B = internal brake chopper A = LED display 20 = IP20 protection type N = Not coated printed circuit boards
DA1-34014FB-B66N	DA1 = DA1 series variable frequency drive 3 = Three-phase mains supply voltage 4 = Mains voltage category: 400 V (380 V - 480 V ±10 %) 014 = Rated operational current: 14 A N = Internal radio interference suppression filter B = internal brake chopper B = OLED display 66 = IP66 protection type N = Not coated printed circuit boards
DA1-34018FB-A20C	DA1 = DA1 series variable frequency drive 3 = Three-phase mains supply voltage 4 = Mains voltage category: 400 V (380 V - 480 V ±10 %) 018 = Rated operational current: 18 A N = Internal radio interference suppression filter B = internal brake chopper A = LED display 20 = IP20 protection type C = Coated printed circuit boards



For DA1-xxxxNx-xxxx devices, an external radio interference suppression filter is required for operation as per IEC/EN 61800-3.

1 DA1 device series

1.4 Rated data

1.4.3 General rated operational data

Technical Data	Formula sign	Unit	Value
General			
Standards			EMC: EN 61800-3:2004+A1-2012 Radio interference: EN 55011: 2010 Safety: EN 61800-5: 2007 Protection type: EN 60529: 1992
Certifications and manufacturer's declarations on conformity			CE, UL, cUL, c-Tick Note: FS8 units are not UL or cUL certified as of this writing
Production quality			RoHS, ISO 9001
Climatic proofing	ρ_w	%	< 95 %, average relative humidity (RH), non-condensing (EN 50178)
Ambient air temperature			
Operation			
IP20 (NEMA 0)	θ	°C	-10 - +50 (frost-free and condensation-free)
IP55 (NEMA 3)	θ	°C	-10 - +45
IP66 (NEMA 4X)	θ	°C	-10 - +40 (frost-free and condensation-free)
Storage	θ	°C	-10 - +60
Electrostatic discharge (ESD, EN 61000-4-2:2009)	V	kV	±4, contact discharge ±8, air discharge
Fast transient burst (EFT/B, EN 61000-4-4: 2004)	V	kV	±1, at 5 kHz, control signal terminals ±2, at 5 kHz, motor connection terminals, single-phase mains connection terminals ±4, at 5 kHz, three-phase mains connection terminals
Overvoltage (surge, EN 61000-4-5: 2006)			
200 - 240 V	V	kV	±1, Phase to phase/neutral conductor ±2, Phase/neutral conductor to earth
380 - 480 V	V	kV	±2, Phase to phase ±4, Phase to earth
Dielectric strength (flash, EN 61800-5-1: 2007)			
200 - 240 V	V	kV	1.5
380 - 480 V	V	kV	2.5
Radio interference class (EMC)			
Category and maximum screened motor cable length			
C1	l	m	5
C2	l	m	25
C3	l	m	50
Mounting position			Vertical, max. ±30°
Altitude	H	m	0 - 1000 above sea level, > 1000 with 1 % load current reduction every 100 m, max. 2000 with UL approval, max. 4000 (without UL)
Degree of protection			IP20 (NEMA 0) IP40 (NEMA 1) IP55 (NEMA 3) IP66 (NEMA 4X)
Busbar tag shroud			BGV A3 (VBG4, finger- and back-of-hand proof)

Technical Data	Formula sign	Unit	Value
General			
Main circuit / power section			
Power supply system			
Rated operational voltage			
DA1-12...	U_e	V	1~ 230 (200 V -10 % - 240 V +10 %)
DA1-32...	U_e	V	3~ 230 (200 V -10 % - 240 V +10 %)
DA1-34...	U_e	V	3~ 400 (380 V -10 % - 480 V +10 %)
Mains frequency	f	Hz	50/60 (48 - 62)
Power factor	$\cos \varphi$		> 96
Phase imbalance		%	max. 3
Maximum short-circuit current (supply voltage)	I_q	kA	5
Mains switch-on frequency			Maximum of one time every 30 seconds
Mains network configuration (AC power supply network)			TN and TT earthing systems with directly earthed neutral point. IT earthing systems with PCM insulation monitoring relays only. Operation on phase-earthed networks is only permissible up to a maximum phase-earth voltage of 300 VAC.
Motor feeder			
Output voltage			
DA1-12..., DA1-32..., DA1-34...	U_2	V	3~ 0 - U_e
Output Frequency			
Range, parameterizable	f_2	Hz	0 - 50/60 (max. 500)
Resolution		Hz	0.1
Overload current			
for 60 s		%	150
for 3 s		%	200
Pulse frequency			
FS2, ..., FS7	f_{PWM}	kHz	max. 32
Operating mode			V/Hz control, slip compensation, vector control
DC braking			
Time before start	t	s	0 - 25, in the event of a stop
Motor pick-up control function (for catching spinning motors)			
Brake chopper			
Braking current during continuous operation		%	100 (I_e)
Maximum braking current		%	150 for 60 s

I DA1 device series

1.4 Rated data

Technical Data	Formula sign	Unit	Value
General			
Control section			
Control Voltage			
Output voltage (control signal terminal 1)	U_C	V DC	24
Load rating (control terminal 1)	I_1	mA	100
Reference voltage (control terminal 5)	U_S	V DC	10
Load rating (control terminal 5)	I_5	mA	10
Digital input (DI)			
Count			3 - 5
Logic (level)			Increase
Response time	t	ms	< 4
Input voltage range High (1)	U_C	V DC	8 - 30
Input voltage range Low (0)	U_C	V DC	0 - 4
Analog Input (AI)			
Count			0 - 2
Resolution			12-bit
Accuracy		%	< 1 to the final value
Response time	t	ms	< 4
Input voltage range	U_S	V DC	-10 - +10, ($R_i \sim 72 \text{ k}\Omega$)
Input current range	I_S	mA	0/4 - 20 ($R_B \sim 500 \Omega$)
Digital output (DO) / relay output (K)			
Count			2 (analog/digital) / 2 relay
Output voltage	U_{out}	V DC	0 - 10, 24
Output current	I_{out}	mA	0/4 - 20
Relays			N/O contact, 6 A (250 V AC) / 5 A (30 V DC) Changeover contacts, 6 A (250 V AC) / 5 A (30 V DC)
Interface (RJ45)			OP bus, Modbus RTU, CANopen
Control level			Control signal terminal/operating unit/interface

1.4.4 Features

Part no.	Rated operational current I_e [A]	Assigned motor power				Radio interference suppression N = No F = Yes	Brake chopper (integrated) N = No B = Yes	Protection type IP	Size FS
		P (230 V, 50 Hz)		P (220 - 240 V, 60 Hz)					
		[kW]	[A] ¹⁾	[HP]	[A] ¹⁾				

Mains supply voltage: 1 AC 230 V**Motor connection voltage: 3 AC 230 V, 50/60 Hz**

DA1-124D3...	4.3	0.75	3.2	1	4.2	F	N	IP20, IP66	FS2
DA1-127D0...	7	1.5	6.3	2	6.8	F	N	IP20, IP66	FS2
DA1-12011...	11	2.2	8.7	3	9.6	F	N, B	IP20, IP66	FS2

Mains supply voltage: 3 AC 230 V, 50/60 Hz**Motor connection voltage: 3 AC 230 V, 50/60 Hz**

DA1-324D3...	4.3	0.75	3.2	1	4.2	F	B	IP20, IP66	FS2
DA1-327D0...	7	1.5	6.3	2	6.8	F	B	IP20, IP66	FS2
DA1-32011...	10.5	2.2	8.7	3	9.6	F	B	IP20, IP66	FS2
DA1-32012...	18	4	14.8	5	15.2	F	B	IP20, IP66	FS3
DA1-32024...	24	5.5	19.6	7.5	22	F	B	IP20, IP66	FS3
DA1-32024...	24	5.5	19.6	7.5	22	F	B	IP55	FS4
DA1-32039...	39	7.5	26.4	10	28	F	B	IP55	FS4
DA1-32046...	46	11	38	15	42	F	B	IP55	FS4
DA1-32061...	61	15	51	20	54	F	B	IP55	FS5
DA1-32072...	72	18.5	63	25	68	F	B	IP55	FS5
DA1-32090...	90	22	71	30	80	F	B	IP55	FS6
DA1-32110...	110	30	96	40	104	F	B	IP55	FS6
DA1-32150...	150	37	117	50	130	F	B	IP55	FS6
DA1-32180...	180	45	141	60	154	F	B	IP55	FS6
DA1-32202...	202	55	173	75	192	F	B	IP55	FS7
DA1-32248...	248	75	233	100	248	F	B	IP55	FS7

1) The rated motor currents apply to normal internally and surface-cooled three-phase asynchronous motor (1500 rpm at 50 Hz, 1800 rpm at 60 Hz).

2) Take motor data into account (6 A = normalized rated value as per UL 580 C)
Operation may be limited to a reduced motor load.

I DA1 device series

1.4 Rated data

Part no.	Rated operational current I_e [A]	Assigned motor power				Radio interference suppression N = No F = Yes	Brake chopper (integrated) N = No B = Yes	Degree of protection IP	Size FS
		P (400 V, 50 Hz)		P (440 - 480 V, 60 Hz)					
		[kW]	[A] ¹⁾	[HP]	[A] ¹⁾				
Mains supply voltage: 3 AC 400 V, 50 Hz / 480 V, 60 Hz									
Motor connection voltage: 3 AC 400 V, 50 Hz / 440 - 480 V, 60 Hz									
DA1-342D2...	2.2	0.75	1.9	1	2.1	F	B	IP20, IP66	FS2
DA1-344D1...	4.1	1.5	3.6	2	3.4	F	B	IP20, IP66	FS2
DA1-345D8...	5.8	2.2	5	3	4.8	F	B	IP20, IP66	FS2
DA1-349D5...	9.5	4	8.5	5	7.6	F	B	IP20, IP66	FS2
DA1-34014...	14	5.5	11.3	7.5	11	F	B	IP20, IP66	FS3
DA1-34018...	18	7.5	15.2	10	14	F	B	IP20, IP66	FS3
DA1-34024...	24	11	21.7	15	21	F	B	IP20, IP66	FS3
DA1-34024...	24	11	21.7	15	21	F	B	IP55	FS4
DA1-34030...	30	15	29.3	20	27	F	B	IP55	FS4
DA1-34039...	39	18.5	36	25	34	F	B	IP55	FS4
DA1-34046...	46	22	41	30	40	F	B	IP55	FS4
DA1-34061...	61	30	55	40	52	F	B	IP55	FS5
DA1-34072...	72	37	68	50	65	F	B	IP55	FS5
DA1-34090...	90	45	81	60	77	F	B	IP55	FS6
DA1-34110...	110	55	99	75	96	F	B	IP55	FS6
DA1-34150...	150	75	134	100	124	F	B	IP55	FS6
DA1-34180...	180	90	161	125	156	F	N, B	IP55	FS6
DA1-34202...	202	110	196	150	180	F	N, B	IP55	FS7
DA1-34240...	240	132	231	200	240	F	N, B	IP55	FS7
DA1-34302...	302	160	279	250	302	F	N, B	IP55	FS7
DA1-34370...	370	200	349	300	361	F	N, B	IP40	FS8
DA1-34450...	450	250	437	350	414	F	N, B	IP40	FS8

1) The rated motor currents apply to normal internally and surface-cooled three-phase asynchronous motor (1500 rpm at 50 Hz, 1800 rpm at 60 Hz).

1.5 DA1 layout

The following drawing shows examples of named elements of the DA1 variable frequency drives in different frame sizes.

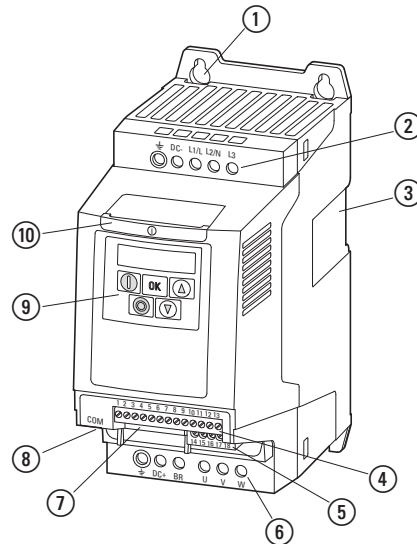

Figure 5: Designation on the DA1 variable frequency drive

- ① Fixing holes (screw fastening)
- ② Connection terminals in power section (mains side)
- ③ Cutout for mounting on mounting rail (only for FS2 and FS3)
- ④ Control terminals (plug-in)
- ⑤ Relay terminals (plug-in)
- ⑥ Connection terminals in power section (motor feeder)
- ⑦ Slot for field bus card or expansion module
- ⑧ Communication interface (RJ45)
- ⑨ Operating unit with 5 control signal terminals and LED display
- ⑩ Info card

1 DA1 device series

1.6 Features

1.6 Features

DA1 series variable frequency drives convert the voltage and frequency of an existing AC supply system into a DC voltage.

This DC voltage is used to generate a three-phase AC voltage with adjustable frequency and assigned amplitude values for the variable speed control of three-phase asynchronous motors.

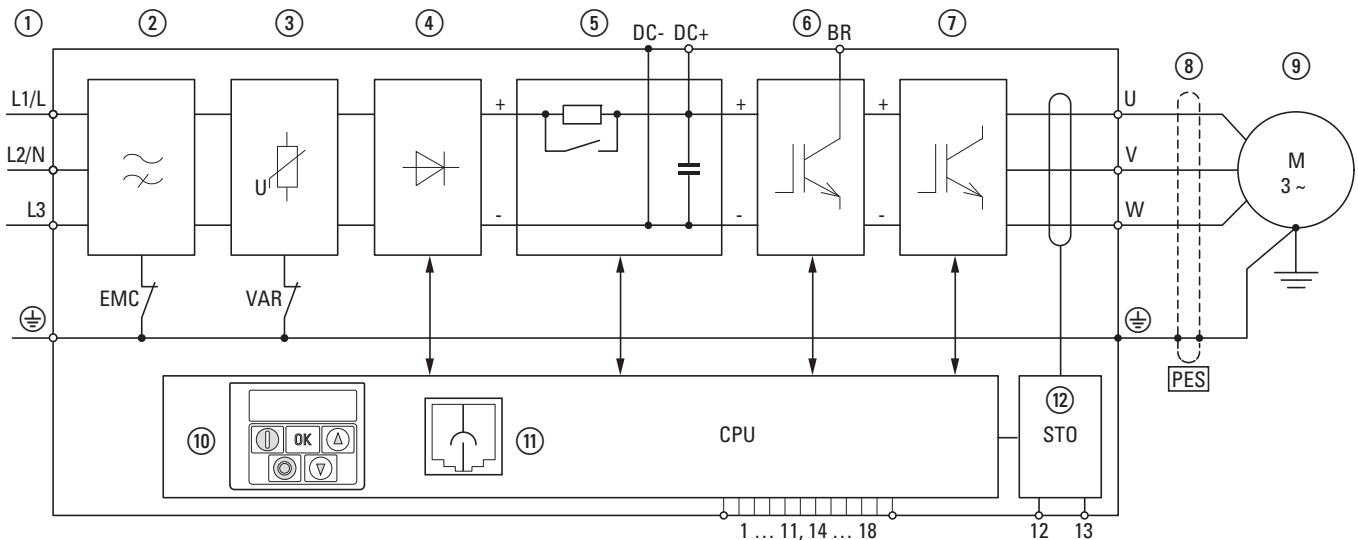

Figure 6: Block diagram; components in a DA1 variable frequency drive

- ① L1/L, L2/N, L3, PE supply, mains supply voltage $U_{LN} = U_e$ at 50/60 Hz:
 DA1-12...: single-phase mains connection (1 AC/2 AC 230 V/240 V), motor feeder (3 AC 230 V)
 DA1-32...: single-phase mains connection (3 AC 230 V/240 V), motor feeder (3 AC 230 V)
 DA1-34...: single-phase mains connection (3 AC 400 V/480 V), motor feeder (3 AC 400 V)
- ② Internal radio interference suppression filter, EMC connection to PE
- ③ Internal voltage filter, VAR connection to PE
- ④ Rectifier bridge: it converts the AC voltage of the electrical supply to a DC voltage.
- ⑤ Internal DC link with charging resistor, capacitor and switched-mode power supply unit (SMPS = Switching-Mode Power Supply).
- ⑥ Brake chopper for external braking resistor (DC+ and BR connection)
- ⑦ Inverter. The IGBT based inverter converts the DC voltage of the DC link (U_{DC}) into a three-phase AC voltage (U_2) with variable amplitude and frequency (f_2).
- ⑧ Motor connection with output voltage U_2 (0 to 100 % U_e) and output frequency f_2 (0 to 500 Hz)
 The connection in the motor feeder is implemented with a screened cable that is earthed on both sides across a large area (PES).
 Rated operational current (I_e , output current):
 DA1-12...: 4.3 - 10.5 A
 DA1-32...: 4.3 - 248 A
 DA1-34...: 2.2 - 450 A
 100 % at an ambient temperature of +50 °C with an overload capability of 150 % for 60 s and a starting current of 175 % for 2 s.
- ⑨ Three-phase asynchronous motor, variable speed control of three-phase asynchronous motor for assigned motor shaft power values (P_2):
 DA1-12...: 0.75 - 2.2 kW (230 V, 50 Hz) oder 1 - 3 HP (230 V, 60 Hz)
 DA1-32...: 0.75 - 75 kW (230 V, 50 Hz) oder 1 - 100 HP (230 V, 60 Hz)
 DA1-34...: 0.75 - 160 kW (400 V, 50 Hz) oder 1 - 255 HP (460 V, 60 Hz)

- ⑩ Control section with operating unit and control buttons, 7-digital display assembly, control voltage, plug-in control signal terminals, plug-in relay terminal
- ⑪ RJ45 interface for the PC and fieldbus connection (Modbus RTU, CANopen)
- ⑫ Safe Torque-Off
Safe removal of torque as per SIL 2 (EN 61508) / PL d (EN ISO 13849-1)

1.7 Selection criteria

Select the variable frequency drive according to the supply voltage U_{LN} of the supply system and the rated operational current of the assigned motor. The circuit type (Δ / Υ) of the motor must be selected according to the rated operational current.

The rated output current I_e of the variable frequency drive must be greater than or equal to the rated motor current.

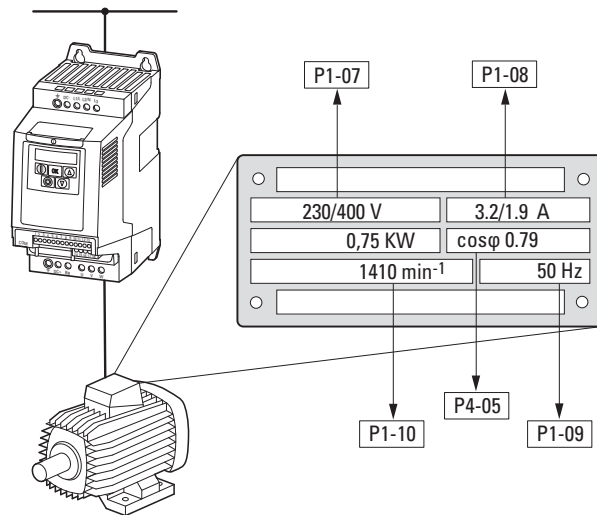

Figure 7: Selection criteria – Rating plate data

When selecting the drive, the following criteria must be known:

- Type of motor
- Mains voltage = rated operating voltage of the motor (e. g. 3~ 400 V),
- Rated motor current (recommended value, dependent on the circuit type and the power supply)
- Load torque (quadratic, constant),
- Starting torque,
- Ambient air temperature (rated value e. g. +40 °C).



When connecting multiple motors in parallel to the output of a variable frequency drive, the motor currents are added geometrically – separated by effective and idle current components.

When you select a variable frequency drive, make sure that it can supply the total resulting current. If necessary, for dampening and compensating the deviating current values, motor reactors or sinusoidal filters must be installed between the variable frequency drive and the motor.

1.8 Proper use

The DA1 variable frequency drives are not domestic appliances. They are designed only for industrial use as system components.

The DA1 variable frequency drives are electrical devices for controlling variable speed drives with three-phase motors. They are designed for installation in machines or for use in combination with other components within a machine or system.

After installation in a machine, the variable frequency drives must not be taken into operation until the associated machine has been confirmed to comply with the safety requirements of Machinery Safety Directive (MSD) 89/392/EEC (meets the requirements of EN 60204). The user of the equipment is responsible for ensuring that the machine use complies with the relevant EU Directives.

The CE markings on the DA1 variable frequency drive confirm that, when used in a typical drive configuration, the apparatus complies with the European Low Voltage Directive (LVD) and the EMC Directives (Directive 73/23/EEC, as amended by 93/68/EEC and Directive 89/336/EEC, as amended by 93/68/EEC).

In the described system configurations, DA1 variable frequency drives are suitable for use in public and non-public networks.

A connection of a DA1 variable frequency drive to IT networks (networks without reference to earth potential) is permissible only to a limited extent, since the device's built-in filter capacitors connect the network with the earth potential (enclosure).

On earth free networks, this can lead to dangerous situations or damage to the device (isolation monitoring required).



To the output (terminals U, V, W) of the DA1 variable frequency drive you must not:

- connect a voltage or capacitive loads (e.g. phase compensation capacitors),
- connect multiple variable frequency drives in parallel,
- make a direct connection to the input (bypass).

Observe the technical data and connection requirements.

For additional information, refer to the equipment nameplate or label of the variable frequency drive and the documentation. Any other usage constitutes improper use.

1 DA1 device series

1.9 Maintenance and inspection

1.9 Maintenance and inspection

DA1 series variable frequency drives will be maintenance-free as long as the general rated operational data (→ Section 1.4.3, "General rated operational data", page 16) is adhered to and the specific technical data (see appendix) for the corresponding ratings is taken into account. Please note, however, that external influences may affect the operation and lifespan of a DA1 variable frequency drive.

We therefore recommend that the devices are checked regularly and the following maintenance measures are carried out at the specified intervals.

Table 2: Recommended maintenance for DA1 variable frequency drives

Maintenance measures	Maintenance interval
Clean cooling vents (cooling slits)	Please enquire
Check the fan function	6 - 24 months (depending on the environment)
Filter in the switching cabinet doors (see manufacturer specifications)	6 - 24 months (depending on the environment)
Check all earth connections to make sure they are intact	On a regular basis, at periodic intervals
Check the tightening torques of the terminals (control signal terminals, power terminals)	On a regular basis, at periodic intervals
Check connection terminals and all metallic surfaces for corrosion	6 - 24 months; when stored, no more than 12 months later (depending on the environment)
Motor cables and shield connection (EMC)	According to manufacturer specifications, no later than 5 years
Charge capacitors	12 months (→ Section 1.11, "Charging the internal DC link capacitors")

There are no plans for replacing or repairing individual components of DA1 variable frequency drives.

If the DA1 variable frequency drive is damaged by external influences, repair is not possible.

Dispose of the device according to the applicable environmental laws and provisions for the disposal of electrical or electronic devices.

1.10 Storage

If the DA1 variable frequency drive is stored before use, suitable ambient conditions must be ensured at the site of storage:

- Storage temperature: -40 - +70 °C,
- Relative average air humidity: < 95 %, non condensing (EN 50178),
- To prevent damage to the RASP DC link capacitors, storage times longer than 12 months are not recommended
(→ Section 1.11, "Charging the internal DC link capacitors").

1.11 Charging the internal DC link capacitors

After extended storage times or extended downtimes during which no power is supplied (> 12 months), the capacitors in the internal DC link must be recharged in a controlled manner in order to prevent damage. To do this, the DA1 variable frequency drive must be supplied with power, with a controlled DC power supply unit, via two mains connection terminals (e.g. L1 and L2).

In order to prevent the capacitors from having excessively high leakage currents, the inrush current should be limited to approximately 300 to 800 mA (depending on the relevant rating). The variable frequency drive must not be enabled during this time (i.e. no start signal). After this, the DC voltage must be set to the magnitudes for the corresponding DC link voltage ($U_{DC} \sim 1.41 \times U_e$) and applied for one hour at least (regeneration time).

- DA1-12..., DA1-32...: about 324 V DC at $U_e = 230$ V AC.
- DA1-34...: about 560 V DC at $U_e = 400$ V AC.

1.12 Service and warranty

In the unlikely event that you have a problem with your DA1 variable frequency drive, please contact your local sales office.

When you call, have the following data ready:

- The exact variable frequency drive part number (see nameplate),
- the date of purchase,
- a detailed description of the problem which has occurred with the variable frequency drive.

If some of the information printed on the rating plate is not legible, please state only the data which are clearly legible.

Information concerning the guarantee can be found in the Terms and Conditions Eaton Industries GmbH.

24-hour hotline: +49 (0)1805 223 822

E-Mail: AfterSalesEGBonn@eaton.com

1 DA1 device series
1.12 Service and warranty

2 Engineering

2.1 Introduction

This chapter describes the most important features in the energy circuit of a magnet system (PDS = Power Drive System), which you should take into consideration in your project planning.

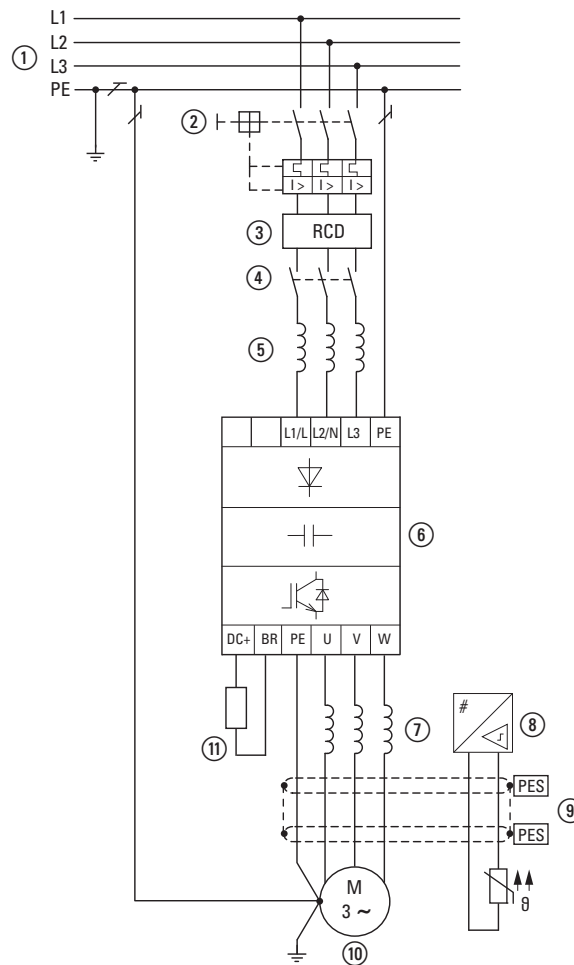

Figure 8: Example of a magnet system with a three-phase feeder unit for a three-phase motor

- ① Network configuration, mains voltage, mains frequency, interaction with p.f. correction systems
- ② Fuses and cable cross-sections, cable protection
- ③ Protection of persons and domestic animals with residual current protective devices
- ④ Mains contactor
- ⑤ Main choke, radio interference filter, line filter
- ⑥ Variable frequency drive: mounting; installation; power connection; EMC compliance; circuit examples
- ⑦ Motor reactor, dV/dt filter, sinusoidal filter
- ⑧ Motor protection; Thermistor overload relay for machine protection
- ⑨ Cable lengths, motor cables, shielding (EMC)
- ⑩ Motor and application, parallel operation of multiple motors on a variable frequency drive (only for V/f), bypass circuit; DC braking
- ⑪ Braking resistance; dynamic braking

2.2 Electrical power network

2.2.1 Mains connection and configuration

The variable frequency drives of the DA1 series can be connected and operated with all control-point grounded AC supply systems (see IEC 60364 for more information in this regard).

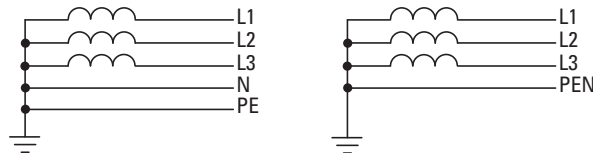

Figure 9: AC power networks with earthed center point (TN-/TT networks)



While planning the project, consider a symmetrical distribution to the three main poles, if multiple variable frequency drives with single-phase incoming unit are to be connected. The total current of all single phase consumers is not to cause an overload of the neutral conductor (N-conductor).

The connection and operation of variable frequency drives to asymmetrically grounded TN networks (phase-grounded Delta network "Grounded Delta", USA) or non-grounded or high-resistance grounded (over 30 Ω) IT networks is only conditionally permissible.



Operation on non-earthed networks (IT) requires the use of suitable insulation monitors (e.g. pulse-code measurement method).



In networks with an earthed main pole, the maximum phase-earth voltage must not exceed 300 VAC.

If DA1 series variable frequency drives are connected to an asymmetrically earthed network or to an IT network (non-earthed, insulated), the internal radio interference suppression filter must be disconnected (by unscrewing the screw marked EMC).

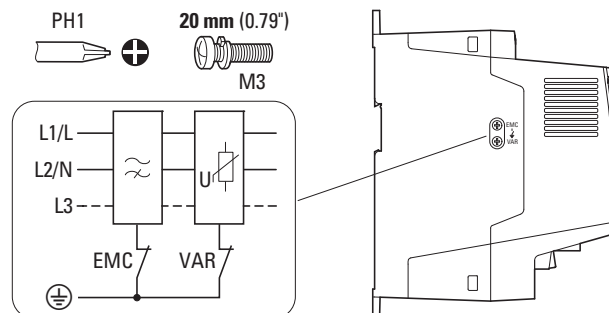

Figure 10: EMC screw location

The required filter winding for electromagnetic compatibility (EMC) no longer exists in this case.



Measures for electromagnetic compatibility are mandatory in a magnet system, to meet the legal standards for EMC- and low-voltage regulations.

Good earthing measures are a prerequisite for the effective insert of further measures such as screen earth kit or filters here. Without respective grounding measures, further steps are superfluous.

2.2.2 Mains voltage and frequency

The standardized rated operating voltages (IEC 60038, VDE 017-1) of power utilities guarantee the following conditions at the connection point:

- Deviation from the rated value of voltage:
maximum $\pm 10\%$
- Deviation in voltage phase balance:
maximum $\pm 3\%$
- Deviation from rated value of the frequency:
maximum $\pm 4\%$

The broad tolerance band of the DA1 variable frequency drive considers the rated value for European as (EU: $U_{LN} = 230\text{ V}/400\text{ V}$, 50 Hz) and American as (USA: $U_{LN} = 240\text{ V}/480\text{ V}$, 60 Hz) standard voltages:

- 230 V, 50 Hz (EU) and 240 V, 60 Hz (USA) at DA1-12..., DA1-32...
200 V - 10 % - 240 V + 10 % (190 V - 0 % - 264 V + 0 %)
- 400 V, 50 Hz (EU) and 480 V, 60 Hz (USA) at DA1-34...
380 V - 10 % - 480 V + 10 % (370 V - 0 % - 528 V + 0 %)

The permissible frequency range for all voltage categories is 50/60 Hz (48 Hz - 0 % - 62 Hz + 0 %).

2.2.3 Voltage balance

Because of the uneven loading on the conductor and with the direct connection of greater power ratings, deviations from the ideal voltage form and asymmetrical voltages can be caused in three-phase AC power networks. These asymmetric divergences in the mains voltage can lead to different loading of the diodes in mains rectifiers with three-phase supplied variable frequency drives and as a result, to an advance failure of this diode.



In the project planning for the connection of three-phase supplied variable frequency drives (DA1-3...), consider only AC supply systems that handle permitted asymmetric divergences in the mains voltage $\leq +3\%$.

If this condition is not fulfilled, or symmetry at the connection location is not known, the use of an assigned main choke is recommended.

2.2.4 Total Harmonic Distortion (THD)

Non-linear consumers (loads) in an AC supply system produce harmonic voltages that again result in harmonic currents. These harmonic currents at the inductive and capacitive reactances of a mains supply system produce additional voltage drops with different values which are then overlaid on the sinusoidal mains voltage and result in distortions. In supply systems, this form of "noise" can give rise to problems in an installation if the sum of the harmonics exceeds certain limit values.

Non-linear consumers (harmonics producers) include for example:

- Induction and arc furnaces, welding devices,
- Current converters, rectifiers and inverters, soft starters, variable frequency drives,
- Switched-mode power supply units (computers, monitors, lighting), uninterruptible power supply (UPS).

The THD value (THD = Total Harmonic Distortion) is defined in standard IEC/EN 61800-3 as the ratio of the rms value of all harmonic components to the rms value of the fundamental frequency.

For example, the THD for a current is:

$$\text{THD} = \frac{\sqrt{\sum_{n=2}^{\infty} I_n^2}}{I_1}$$

Where I_1 is the rms value of the fundamental frequency current and n is the order of a harmonic with its own frequency, which is an integer multiple of the fundamental frequency (Fourier analysis).

Example: 5th harmonic of a mains frequency of 50 Hz : $5 \times 50 \text{ Hz} = 250 \text{ Hz}$.

The THD value of the harmonic distortion is stated in relation to the rms value of the total signal as a percentage. On a variable frequency drive, the total harmonic distortion is around 120 %. A mains choke (such as 4 % u_k) on the supply side of a variable frequency drive enables the THD value with a single-phase supply (B2 diode rectifier bridge) to be reduced to around 80 % and with a three-phase supply (B6 diode rectifier bridge) to around 50 %. The supply quality is thus improved and the mains supply distortion is reduced. The power factor is also improved.

2.2.5 Idle power compensation devices

Compensation on the power supply side is not required for the variable frequency drives of the DA1 series. From the AC power supply network they only take on very little reactive power of the fundamental harmonics ($\cos \varphi \sim 0.98$).



In the AC supply systems with non-choked reactive current compensation devices, current deviations can enable parallel resonance and undefinable circumstances.

In the project planning for the connection of variable frequency drives to AC supply systems with undefined circumstances, consider using main chokes.

2.2.6 Mains chokes

Main chokes (also known as commutating chokes) increase the choke of the mains supply cable. This extends the current flow period and dampens mains deviations.

These reduce the total harmonic distortion, the mains feedback and improve the power factor. The apparent current on the mains side is then reduced by around 30 %.

Towards the variable frequency drive, the main chokes dampen the interference from the supply network. This increases the electric strength of the variable frequency drive and lengthens the lifespan (diodes of the mains rectifier, internal DC link capacitors).



For the operation of the DA1 variable frequency drive, the application of main chokes is not necessary. We do recommend however that an upstream mains choke is used since the network quality is not known in most cases.

While planning the project, consider that a main choke is only assigned to a single variable frequency drive for decoupling.

When using an adapting transformer (assigned to a single variable frequency drive), a main choke is not necessary.

Main chokes are designed based on the mains-side input current (I_{LN}) of the variable frequency drive.

2.3 Safety and switching

2.3.1 Fuses and cable cross-sections

The fuses and wire cross-sections allocated for power-side connections depend on the rated mains current I_{LN} of the variable frequency drive (without main choke).

NOTICE

When selecting the cable cross-section, take the voltage drop under load conditions into account.

The consideration of other standards (e.g. VDE 0113 or VDE 0289) is the responsibility of the user.

The recommended fuses and their assignment to the variable frequency drives are listed in Page 218 the appendix.

The national and regional standards (for example VDE 0113, EN 60204) must be observed and the necessary approvals (for example UL) at the site of installation must be fulfilled.

When the device is operated in a UL-approved system, use only UL-approved fuses, fuse bases and cables. The permissible cables must have a heat resistance of 75 °C.

The connection terminals marked with \oplus and the metallic enclosure (IP66) must be connected to the earth-current circuit.

The leakage currents to earth (as per EN 50178) are greater than 3.5 mA. They are listed for the individual ratings in the appendix, under the specific technical data on Page 203.



As per the requirements in standard EN 50178, a protective earth (PE) must be connected. The cable cross-section must be at least 10 mm² or consist of two separately connected earthing cables.

NOTICE

The specified minimum PE conductor cross-sections (EN 50178, VDE 0160) must be maintained.

A completely (360°) screened low impedance cable on the motor side is required. The length of the motor cable depends on the RFI class and the environment.



Choose the cross-section of the PE conductor in the motor lines at least as large as the cross-section of the phase lines (U, V, W).

2.3.2 Residual current device

Residual current devices (RCD) are also known as residual current device (GFCI) or residual current circuit breaker (RCCB).

Residual current devices protect people and farm animals from the presence (not the production!) of impermissibly high touch voltages. They prevent dangerous (including fatal) injuries caused by electrical accidents and also serve to prevent fires.



Residual current devices must be suitable for:

- the protection of installations with DC current component in case of fault scenario (RCD, type B),
- high leakage currents (300 mA),
- Briefly diverting surge currents



CAUTION

Only AC/DC sensitive residual current devices (RCD, type B) may be used with variable frequency drives (EN 50178, IEC 755).

Marking on the residual current device

AC/DC sensitive (RCD, part no. B)



Variable frequency drives work internally with rectified AC currents. If an error occurs, the DC currents can block an RCD safety device of type A from triggering and therefore disable the protective functionality.

NOTICE

Residual current devices (RCD) are only to be installed between the AC power supply network and the variable frequency drive.



Safety-relevant leakage currents can occur while handling and when operating the variable frequency drive, if the variable frequency drive is not earthed.

Leakage currents to earth are mainly caused by foreign capacities with variable frequency drives: between the motor phases and the shielding of the motor cable and via the star capacitor of the radio interference suppression filter.

2 Engineering

2.4 EMC compliance

The size of the leakage currents is mainly dependent upon the:

- length of the motor cable,
- shielding of the motor cable,
- height of the pulse frequency (switching frequency of the inverter),
- Design of the radio interference suppression filter
- grounding measures at the site of the motor.

2.3.3 Mains contactors

The mains contactor enables an operational switching on and off of the supply voltage for the variable frequency drive and switching off in case of a fault.

The mains contactor is designed based on the mains-side input current I_{LN} of the variable frequency drive for utilization category AC-1 (IEC 60947) and the ambient air temperature at the location of use. Mains contactors and their assignment to the variable frequency drives belonging to the DC1 series are listed in the appendix (Table 27, page 220).



While planning the project, make sure that inching operation is not done via the mains contactor of the variable frequency drive on frequency-controlled drives, but through a controller input of the variable frequency drive.

The maximum permissible mains voltage switch-on frequency for the DA1 variable frequency drive is once every 30 seconds (normal operation).

2.4 EMC compliance

Electrical components in a system (machine) have a reciprocal effect on each other. Each device not only emits interference but is also affected by it. This occurs as a result of galvanic, capacitive and/or inductive coupling or through electromagnetic radiation. In practice, the limit between line-conducted interference and emitted interference is around 30 MHz. At values above 30 MHz the lines and cables act like antennas and radiate the electromagnetic waves.

Electromagnetic compatibility (EMC) for frequency controlled drives (variable speed drives) is implemented in accordance with product standard IEC/EN 61800-3. This includes the complete power magnet system (PDS = Power Drive System), from the mains supply to the motor, including all components, as well as cables (→ Figure 8, page 29). This type of drive system can also consist of several individual drives.

The generic standards of the individual components in a magnet system compliant with IEC/EN 61800-3 do not apply. These component manufacturers, however, must offer solutions that ensure standards-compliant use.

In Europe, maintaining the EMC Directive is mandatory.

A declaration of conformity (CE) refers always to a “typical” power magnet system (PDS). The responsibility to comply with the legally stipulated limit values and thus the provision of electromagnetic compatibility is ultimately the responsibility of the end user or system operator. Measures must be taken to remove or minimize emission in the associated environment (→ Figure 11). He must also utilize means to increase the interference immunity of the devices of the system.

With their high interference immunity up to category C3, DA1 variable frequency drives are ideal for use in harsh industrial networks (2nd environment).

The DA1...-F... version (with integrated RFI filter) makes it possible to comply with the stringent limit values for conducted emission for category C1 in the 1st environment. This requires a correct EMC installation (→ Page 53) and the observance of the permissible motor cable lengths and the maximum switching frequency (f_{PWM}) of the inverter.

In the case of variable frequency drives without an internal radio interference suppression filter, longer motor cable lengths and lower leakage currents can sometimes be achieved for the individual categories by using a dedicated external radio interference suppression filter.

The required EMC measures should be taken into account in the engineering phase. Improvements and modifications during mounting and installation or even at the installation site involve additional and even considerably higher costs.

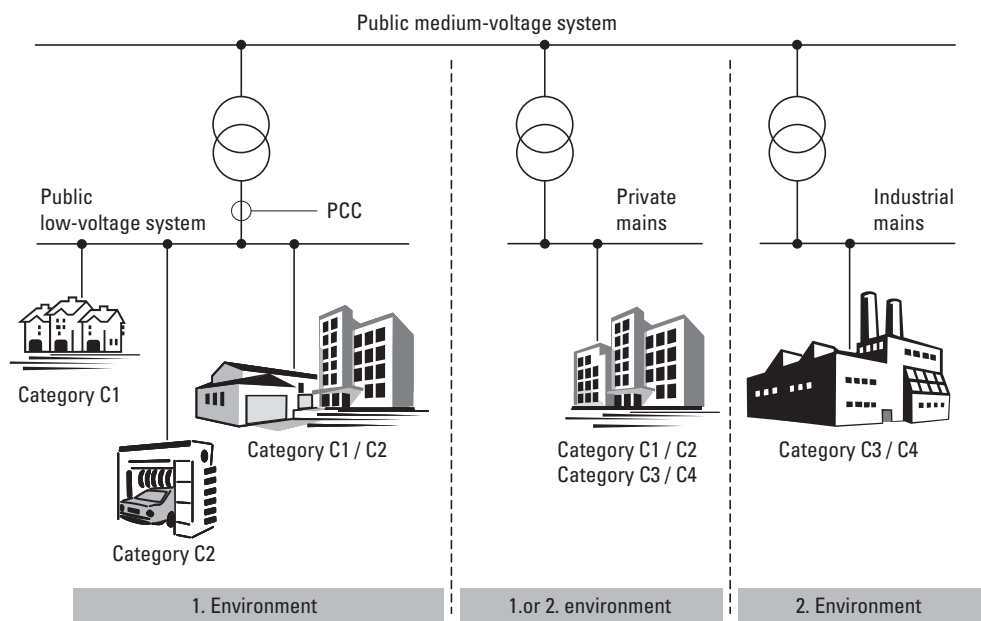

Figure 11: EMC environment and categories

2.5 Motor and Application

2.5.1 Motor selection

General recommendations for motor selection:

- For a frequency-controlled magnet system (PDS), use three-phase AC motors with squirrel-cage rotors and surface cooling, also known as three-phase asynchronous motors or standard motors. Other types of motors, such as external rotor motors, wound-rotor motors, reluctance motors, permanent-magnet motors, synchronous motors, and servomotors can also be operated with a variable frequency drive, but normally require additional engineering in consultation with the motor's manufacturer.
- Only use motors that have insulation class F (maximum steady state temperature of 155 °C) at least.
- Choose 4 pole motors preferably (synchronous speed: 1500 min⁻¹ at 50 Hz and 1800 min⁻¹ at 60 Hz).
- Take the operating conditions into account for S1 operation (IEC 60034-1).
- When operating multiple motors in parallel on one variable frequency drive, the motor output should not be more than three power classes apart.
- Ensure that the motor is not overdimensioned. If it is underdimensioned in the "speed control" (slip compensation) operating mode, the motor output may only be one single assigned output level lower.

2.5.2 Parallel connection of motors

The DA1 variable frequency drives allow parallel operation of several motors in "V/f control mode":

- With multiple motors with the same or different rated operational data: The total of the motor currents must be less than the rated operational current of the variable frequency drive.
- Connecting and disconnecting individual motors: The total of the motor currents in operation, plus the motor's inrush current, must be less than the rated operational current of the variable frequency drive.

Parallel operation at different motor speeds can be implemented only by changing the number of pole pairs and/or changing the motor's transmission ratio.

Connecting motors in parallel reduces the load resistance at the variable frequency drive output. The total stator inductance is lower and the leakage capacity of the lines greater. As a result, the current distortion is greater than in a single-motor circuit.

To reduce the current distortion, you should use motor reactors (see ① in Figure12) in the output of the variable frequency drive.

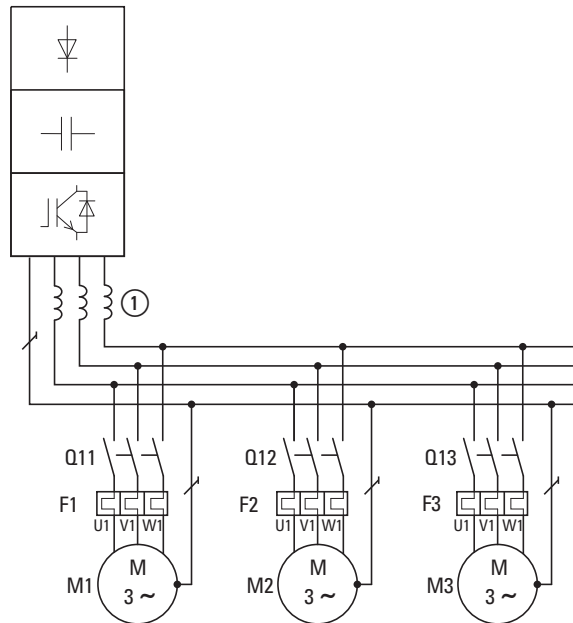

Figure 12: Parallel connection of several motors to one variable frequency drive

NOTICE

If multiple motors are connected in parallel to a single variable frequency drive, make sure to dimension the individual motors' contactors for utilization category AC-3. The motor contactor must be selected according to the rated operational current of the motor that will be connected.

- ➔ The current consumption of all motors connected in parallel must not exceed the variable frequency drive's rated output current I_{2N} .
- ➔ When operating multiple motors in parallel, you cannot use the variable frequency drive's electronic motor protection. You will have to protect each motor individually with thermistors and/or a current transformer-operated overload relay.
- ➔ The use of motor-protective circuit-breakers at the output of variable frequency drives can result in motors being disconnected in an undefined manner and is only possible in select applications.

2.5.3 Circuit types with three-phase motors

The three-phase motor's stator winding can be connected in a star or delta circuit as per the rated operational data on the rating plate.

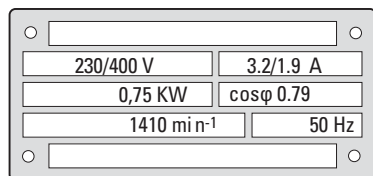

Figure 13: Example of a motor rating plate

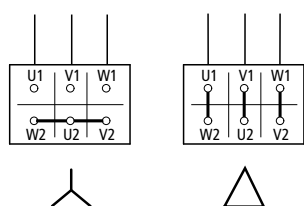

Figure 14: Configuration types:
Star-connected circuit (left), delta circuit (right)

2.5.4 87-Hz Characteristic curve

The three-phase motor with the rating plate in Figure 13 can be operated with either a star or delta circuit. The operational characteristic curve is determined by the ratio of motor voltage to motor frequency in this case.

The 87 Hz characteristic curve is used to operate the three-phase standard motor with the rating plate in Figure 13 with a delta circuit on a 400 V network at 87 Hz. To enable this, the variable frequency drive must deliver the higher current for delta circuits (3.2 A) and the motor frequency (V/Hz key point) must be set to 87 Hz on the variable frequency drive.

This results in the following advantages:

- The motor's speed adjustment range is increased by a factor of $\sqrt{3}$ (from 50 Hz to 87 Hz)
- The motor's efficiency is improved, since the motor speed increases while the (absolute) slip remains the same and therefore is smaller, percentage-wise, relative to the new (higher) speed.
- Greater power can be taken from the motor ($P \sim M \times n$), making it possible in some cases to use a motor one size smaller (and therefore more affordable) for the application (e.g. travel motor in crane drives)
- The machine speed of existing machines can be increased without having to change the motor and/or transmission. In other words, operation does not take place within the field-weakening range.



Due to the higher thermal load, it is recommended to only use the next higher listed motor output and to only use motors with an insulation class of F at the very least.



If using 2 pole motors ($p = 1$), the high speed of approximately 5,000 rpm must be taken into account. Consult the manufacturer's specifications.

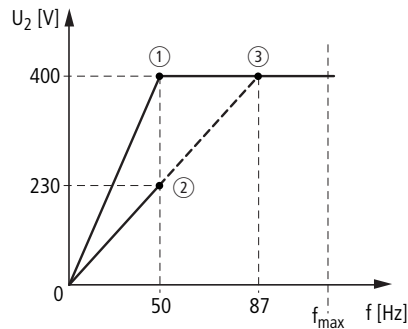

Figure 15: V/Hz characteristic curve for the rating plate of the motor from → Figure 13

- ① Star connection: 400 V, 50 Hz
- ② Delta circuit: 230 V, 50 Hz
- ③ Delta connection: 400 V, 87 Hz

The following Tabelle 3 shows the allocation of possible variable frequency drives depending on the mains voltage and the type of circuit.

Table 3: Assignments between variable frequency drives and V/Hz characteristic curve (→ Figure 15)

Physical parameters	DA1-124D3...	DA1-324D3...	DA1-342D2...	DA1-344D1...
Rated operational current	4.3 A	4.3 A	2.2 A	4.1 A
Mains voltage	1 AC 230 V	3 AC 230 V	3 AC 400 V	3 AC 400 V
V/f-characteristic curve	②	②	①	③
Motor circuit	Delta circuit (230 V)	Delta circuit (230 V)	Star-connected circuit (400 V)	Delta circuit (230 V)
Motor current	3.5 A	3.5 A	2.0 A	3.5 A
Motor voltage	3 AC 0 - 230 V	3 AC 0 - 230 V	3 AC 0 - 400 V	3 AC 0 - 400 V
Motor speed	1430 min ⁻¹	1430 min ⁻¹	1430 min ⁻¹	2474 min ⁻¹ 1)
Motor frequency	50 Hz	50 Hz	50 Hz	87 Hz ¹⁾

1) Note the permitted limit values of the motor!

2.5.5 Bypass operation

When it is necessary to be able to power the motor directly with mains voltage independently from the variable frequency drive (bypass operation), the branches must be mechanically interlocked.

NOTICE

The system may only switch (S1) between the variable frequency drive (T1) and mains voltage (see Figure16) while in a de-energized state.



CAUTION

The variable frequency drive's outputs (U, V, W) must not be connected to the mains voltage (destruction risk, fire hazard).

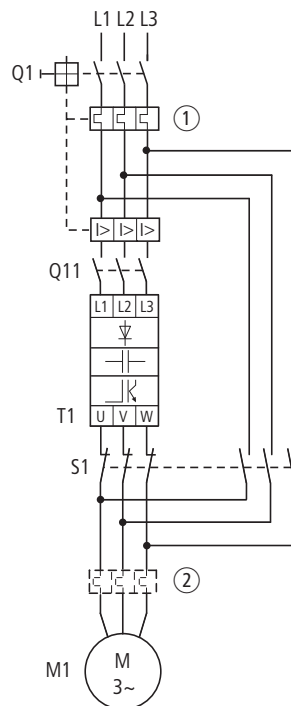

Figure 16: Bypass motor control (example)



When running the motor directly with mains voltage, protective measures (circuit-breaker with thermal overload protection ① or overload relay ②) against overload must be in place.



Contactors and switches (S1) in the variable frequency drive output and for the direct start must be designed based on utilization category AC-3 for the rated operational current of the motor.

2.5.6 Connecting EX motors

The following aspects must be taken into account when connecting explosion-proof motors:

- The variable frequency drive must be installed outside the EX area.
- All applicable industry-specific and country-specific regulations for hazardous locations (ATEX 100a) must be complied with.
- The specifications and instructions provided by the motor's manufacturer with regard to operation with a variable frequency drive – e.g., whether motor reactors (dV/dt limiting) or sinusoidal filters are required – must be taken into account.
- Temperature monitors in the motor windings (thermistor, Thermo-Click) must not be connected directly to the variable frequency drive, but instead must be connected through a relay approved for the hazardous location (e.g. EMT6).

2.5.7 Sinusoidal filter

Sinusoidal filters are connected in the output of a variable frequency drive.

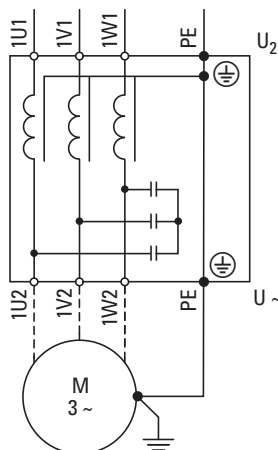

Figure 17: Circuit Diagram of a sinusoidal filter

The sinusoidal filter removes high-frequency components above the set resonance frequency from the variable frequency drive output voltage (U_2). This reduces the conducted and radiated emission.

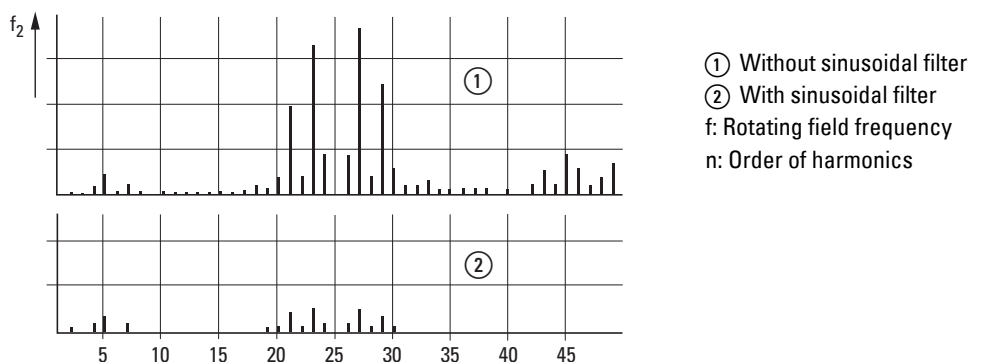

Figure 18: High frequency components of the output voltage

The output voltage of the sinusoidal filter (U_{\sim}) achieves a sinusoidal shape with a slight superimposed ripple voltage.

The THD factor of the sinusoidal voltage is normally 5 to 10 %.

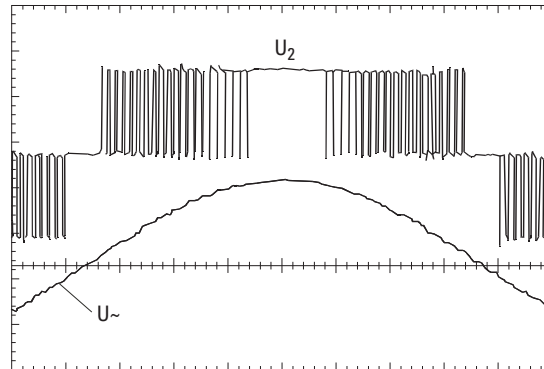

Figure 19: Output voltage to motor
 U_2 : Variable frequency drive output voltage
 U_{\sim} : Simulated sinusoidal voltage

Advantages of sinusoidal filters:

- Long motor cable lengths with reduced conducted and radiated interference
- Reduced motor losses and noise
- Longer motor lifespan

Disadvantages of sinusoidal filters:

- Voltage drop of up to 9 % caused by system (approx. 36 V if $U_2 = 400$ V)
- higher heat dissipation,
- A fixed pulse frequency is required
- Require more space inside the control panel

NOTICE

Sinusoidal filters must only be used with permanently set pulse frequencies.

3 Installation

3.1 Introduction

This chapter explains how to install and electrically connect DA1 series variable frequency drives.



While mounting and/or assembling the variable frequency drive, cover all ventilation slots in order to ensure that no foreign bodies can enter the device.



Perform all installation work with the specified tools and without the use of excessive force.

3.2 Mounting

The instructional leaflets in this section are meant to show how to install the device in a suitable enclosure for devices with protection type IP20 in compliance with standard EN 60529 and/or any other applicable local regulations.

- The enclosures must be made of a material with high thermal conductivity.
- If a control panel with ventilation openings is used, the openings must be located above and below the variable frequency drive in order to allow for proper air circulation. The air should come in from below the variable frequency drive and leave above it.
- If the environment outside the control panel contains dirt particles (e.g., dust), a suitable particulate filter must be placed on the ventilation openings and forced ventilation must be used. The filters must be maintained and cleaned if necessary.
- An appropriate enclosed control panel (without ventilation openings) must be used in environments containing large percentages or amounts of humidity, salt, or chemicals.

3 Installation

3.2 Mounting

3.2.1 Mounting position

DA1 series variable frequency drives are designed to be mounted vertically. The maximum permissible inclination is 30°.

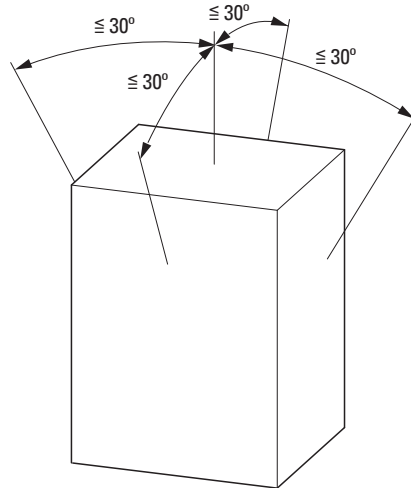

Figure 20: Mounting position

3.2.2 Cooling measures

In order to guarantee sufficient air circulation, enough thermal clearance must be ensured according to the frame size (rating) of the variable frequency drive.

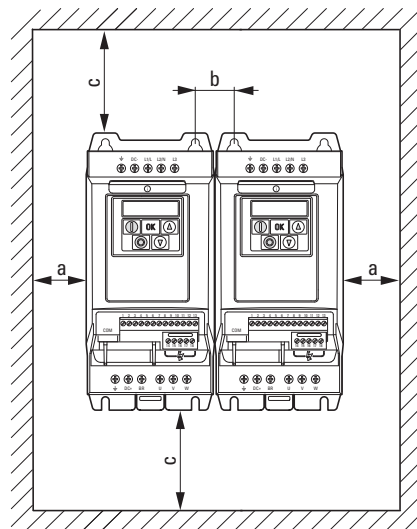

Figure 21: Space for air-cooling

Table 4: Minimum clearance and required cooling air

Size	a		b		c		d		Air through-put	
	[mm]	[in]	[mm]	[in]	[mm]	[in]	[mm]	[in]	[m ³ /h]	[ft ³ /min]
FS2	50	1.97	46	1.81	75	2.95	75	2.95	18.7	11
FS3	50	1.97	52	2.05	100	3.94	100	3.94	44.2	26
FS4	10	0.39	71	2.8	200	7.87	200	7.87	–	–
FS5	10	0.39	70	2.76	200	7.87	200	7.87	–	–
FS6	10	0.39	140	5.52	200	7.87	200	7.87	–	–
FS7	10	0.39	140	5.52	200	7.87	200	7.87	–	–

The values in 4 are recommended values for an ambient air temperature of up to +50 °C, an installation altitude of up to 1000 m, and a pulse frequency of up to 8 kHz.



Typical heat loss makes up about 3 % of the operational load conditions.

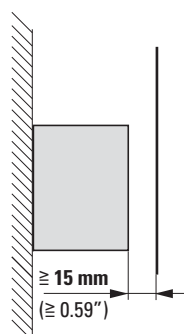

Figure 22: Minimum required clearance in front of the variable frequency drive



Please note that the mounting makes it possible to open and close the control signal terminal covers without any problems.

When variable frequency drives with internal fans are installed vertically over each other, an air baffle must be placed between the devices. Failure to do so may expose the device on top to a thermal overload caused by the guided air flow (device fan).

3 Installation

3.2 Mounting

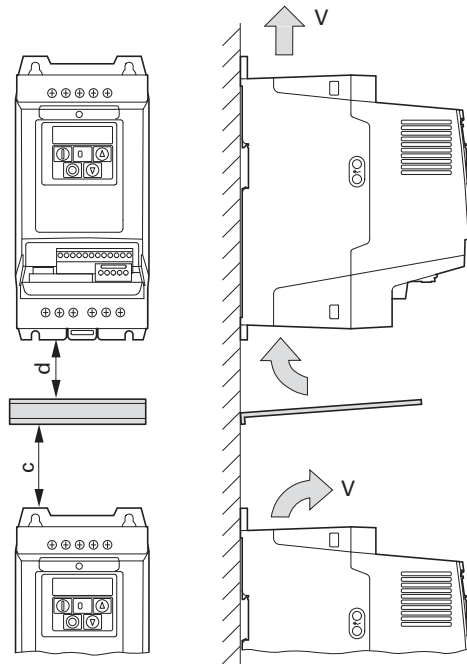

Figure 23: Air baffle due to increased circulation with device fan



Devices with high magnetic fields (e.g. reactors or transformers) should not be installed close to the variable frequency drive.

3.2.3 Control panel installation

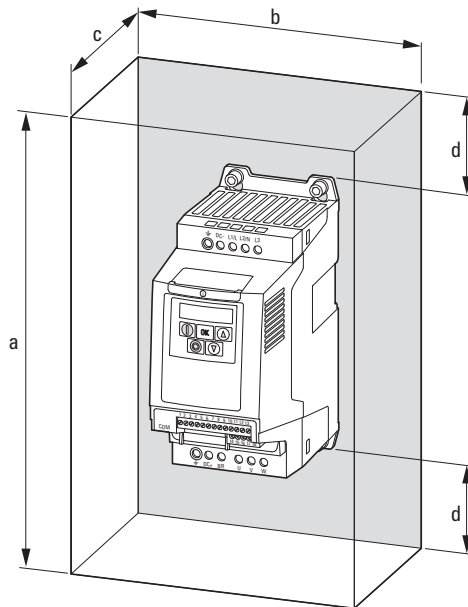

Figure 24: Control panel dimensioning

Calculation of control panel surface:

$$A = \frac{P_V}{\Delta T \times K} \text{ [m}^2\text{]}$$

A = Control panel surface [m²] calculated according to IEC 890)

P_V = Total heat dissipation [W] of all fitted devices

ΔT = Temperature difference [K], (default value = 5.5 K)

K = Heat transfer coefficient [W/(m² x K)]
(standard value = 5.5 for steel control panels)

3.2.4 Fixing

Variable frequency drives with frame sizes of FS2 and FS3 can be fastened with screws or on a mounting rail. Sizes FS4 to FS8 can only be fastened using screws.

- ➔ Install the variable frequency drive only on a nonflammable mounting base (e.g., on a metal plate).
- ➔ Dimension and weight specifications for the DA1 variable frequency drive can be found in the appendix (➔ Page 209).

3.2.4.1 Fixing with screws

- ➔ The number and layout of required mounting dimensions a_1 and b_1 , the tightening torque for the screws, etc. are listed in ➔ Section 9.2, "Dimensions and frame size".
- ➔ Use screws with a washer and split washer with the permissible tightening torque in order to protect the enclosure and safely and reliably mount the device.

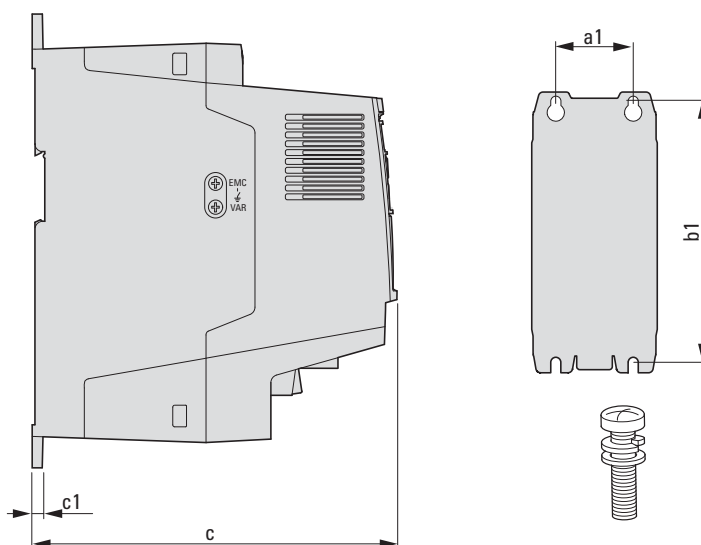

Figure 25: Mounting dimensions

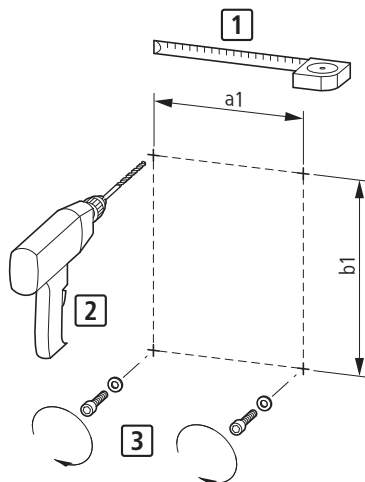

Figure 26: Mounting preparation

- ▶ First fit the screws at the specified positions, mount the variable frequency drive and then fully tighten all screws.



The permitted maximum tightening torque for the fixing screws is 1.3 Nm.

3.2.4.2 Fixing on mounting rails

As an alternative to screw mounting, DA1 variable frequency drives of sizes FS2 and FS3 can also be mounted on a mounting rail as per IEC/EN 60715.

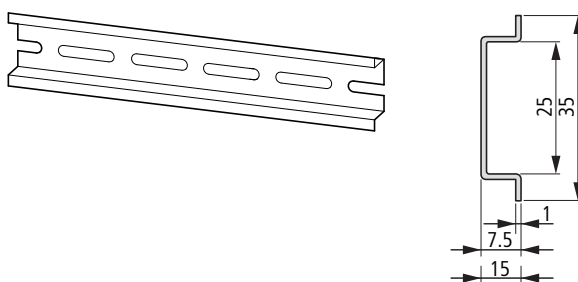

Figure 27: Mounting rail conforming with IEC/EN 60715

- ▶ To do this, place the variable frequency drive on the mounting rail from above [1] and press it down until it snaps into place [2].

3 Installation

3.2 Mounting

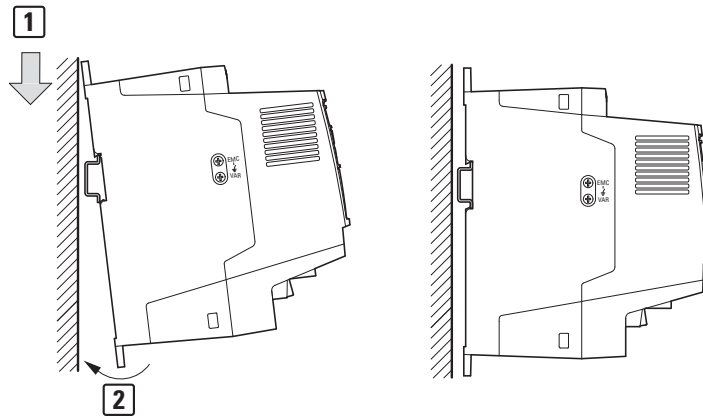

Figure 28: Fixing to the mounting rail

Dismantling from mounting rails

- ▶ To remove the device, push down the spring-loaded clip. A cutout marked on the lower edge of the device is provided for this purpose. A flat-bladed screwdriver (blade width 5 mm) is recommended for pushing down the clip.

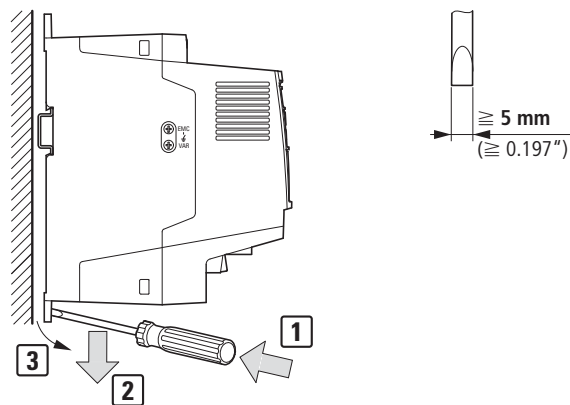

Figure 29: Dismantling from mounting rails

3.3 EMC installation

The responsibility to comply with the legally stipulated limit values and thus the provision of electromagnetic compatibility is the responsibility of the end user or system operator. This operator must also take measures to minimize or remove emission in the environment concerned (→ Figure 11, page 37). He must also utilize means to increase the interference immunity of the devices of the system.

In a magnet system (PDS) with variable frequency drives, you should take measures for electromagnetic compatibility (EMC) while doing your engineering, since changes or improvements to the installation site, which are required in the installation or while mounting, are normally associated with additional higher costs as well.

The technology and system of a variable frequency drive cause the flow of high frequency leakage current during operation. All grounding measures must therefore be implemented with low impedance connections over a large surface area.

With leakage currents greater than 3.5 mA, in accordance with VDE 0160 or EN 60335, either

- the cross-sectional area of the protective conductor must be $\geq 10 \text{ mm}^2$,
- The protective conductor must be open-circuit monitored, or
- the second protective conductor must be fitted.

For an EMC-compliant installation, we recommend the following measures:

- Installation of the variable frequency drive in a metallically conductive housing with a good connection to ground,
- screened motor cables (short cables).



Ground all conductive components and housings in a magnet system using as short a line as possible with the greatest possible cross-section (Cu-drain wire).

3.3.1 EMC measures in the control panel

For the EMC-compatible installation, connect all metallic parts of the device and the switching cabinet together over broad surfaces and so that high-frequencies will be conducted. Mounting plates and control panel doors should make good contact and be connected with short HF-drain wires. Avoid using painted surfaces (Anodized, chromized). An overview of all EMC measures is provided in Figure31 on Page 53.



Install the variable frequency drive as directly as possible (without spacers) on a metal plate (mounting plate).



Route mains and motor cables in the switch cabinet as close to the ground potential as possible. This is because free moving cables act as antennas.

3 Installation

3.3 EMC installation



When laying HF cables (e.g. shielded motor cables) or suppressed cables (e.g. mains supply cables, control circuit and signal cables) in parallel, a minimum clearance of 300 mm should be ensured in order to prevent the radiation of electromagnetic energy. You should also use separate cable entries if there is a great difference in voltage potentials. Any necessary crossed cabling between the control signal and power cables should always be implemented at right angles (90 degrees).



Never lay control- or signal cables in the same duct as power cables. Analog signal cables (measured, reference and correction values) must be screened.

3.3.2 Earthing

The protective earth (PE) in the control panel should be connected from the mains supply to a central earth point (mounting plate, system earth). The PE conductor's cross-sectional area must be at least as large as that of the incoming mains supply cable.

Every variable frequency drive must be individually connected to the power supply system's protective earth directly at the location of installation (system earthing). This protective earth must not pass through any other devices.

All protective conductors should be routed in a star topology starting from the central earth point, and all of the drive system's conductive components (variable frequency drive, motor reactor, motor filter, main choke) should be connected.

The earth-fault loop impedance must comply with all locally applicable industrial safety regulations. In order to meet UL requirements, UL-listed ring cable lugs must be used for all earth wiring connections.



Avoid ground loops when installing multiple variable frequency drives in one control panel. Make sure that all metallic devices that are to be grounded have a broad area connection with the mounting plate.

3.3.2.1 Protective earth

This refers to the legally required protective earth for a variable frequency drive. An earthing terminal on the variable frequency drive, or the system earth, must be connected to a neighboring steel element in the building (beam, ceiling joist), an earth electrode in the ground, or a mains earth bus. The earth points must meet the requirements set forth by the applicable national and local industrial safety regulations and/or regulations for electrical systems.

3.3.2.2 Motor earthing

The motor earth must be connected to one of the earthing terminals on the variable frequency drive and to a neighboring steel element in the building (beam, ceiling joist), an earth electrode in the ground, or a mains earth bus.

3.3.2.3 Earth-fault protection

A fault current to earth can be produced by variable frequency drives due to their system characteristics. DA1 series variable frequency drives have been designed in such a way that the smallest possible fault current will be produced in compliance with standards applicable worldwide. This fault current must be monitored by a residual current device (RCD, type B).

3.3.3 EMC screw

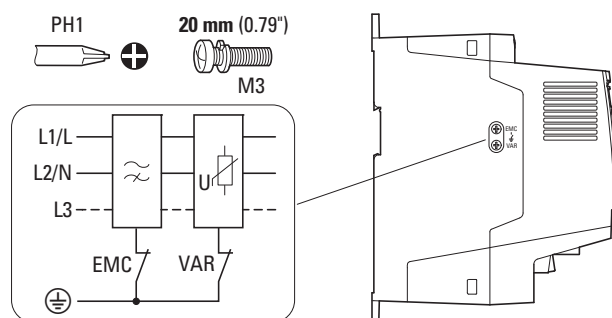

Figure 30: EMC and VAR screws in a DA1 variable frequency drive with protection type IP20

NOTICE

The screw labeled EMC must not be manipulated as long as the variable frequency drive is connected to the mains.



The EMC screw galvanically connects the EMC filter's capacitors to earth. The screw must be screwed in all the way to the stop (factory setting) in order for the variable frequency drive to comply with the EMC standard.

Due to their system characteristics, variable frequency drives with an internal EMC filter will produce a larger fault current to earth than devices without a filter. For applications in which this larger leakage current may cause malfunction messages or disconnections (residual current device), the EMC filter's internal protective earth can be disconnected (remove the EMC screw to do this). Local EMC regulations must be taken into account when doing so. If necessary, a specific low-leakage-current EMC filter must be connected upstream.

3 Installation

3.3 EMC installation

In connections to isolated power sources (IT networks), the EMC screw should be removed. The earth fault monitors required for IT networks must be suitable for operation with power electronic devices (IEC 61557-8).

3.3.4 VAR screw

DA1 series variable frequency drives are equipped with an overvoltage filter for the input supply voltage that is designed to protect the devices from noise pulses in the mains voltage. Pulse spikes are typically caused by lightning strikes or by switching operations in other high-power devices on the same supply.

If high potential tests are performed on a system, these overvoltage protection components may cause the system to fail the test. In order to make it possible to perform this type of hipot tests, the overvoltage protection components can be disconnected by removing the VAR screw. The screw must be screwed back in after the high potential tests are performed and the test must then be repeated. The system must then fail the test, indicating that the overvoltage protection components have been reconnected.

NOTICE

The screw labeled VAR (→ Figure 30, page 55) must not be manipulated as long as the variable frequency drive is connected to the mains.

3.3.5 Screen earth kit

Cables that are not screened work like antennas (sending, receiving).



For a proper EMC connection, cables emitting interference (e.g. motor cables) and susceptible cables (analog signal and measurement values) must be screened and laid separately from each other.

The effectiveness of the cable shield depends on a good shield connection and a low shield resistance.



Use only shields with tinned or nickel-plated copper braiding. Braided steel shields are unsuitable.



Control and signal lines (analog, digital) should always be grounded on one end, in the immediate vicinity of the supply voltage source (PES).

3 Installation

3.3 EMC installation

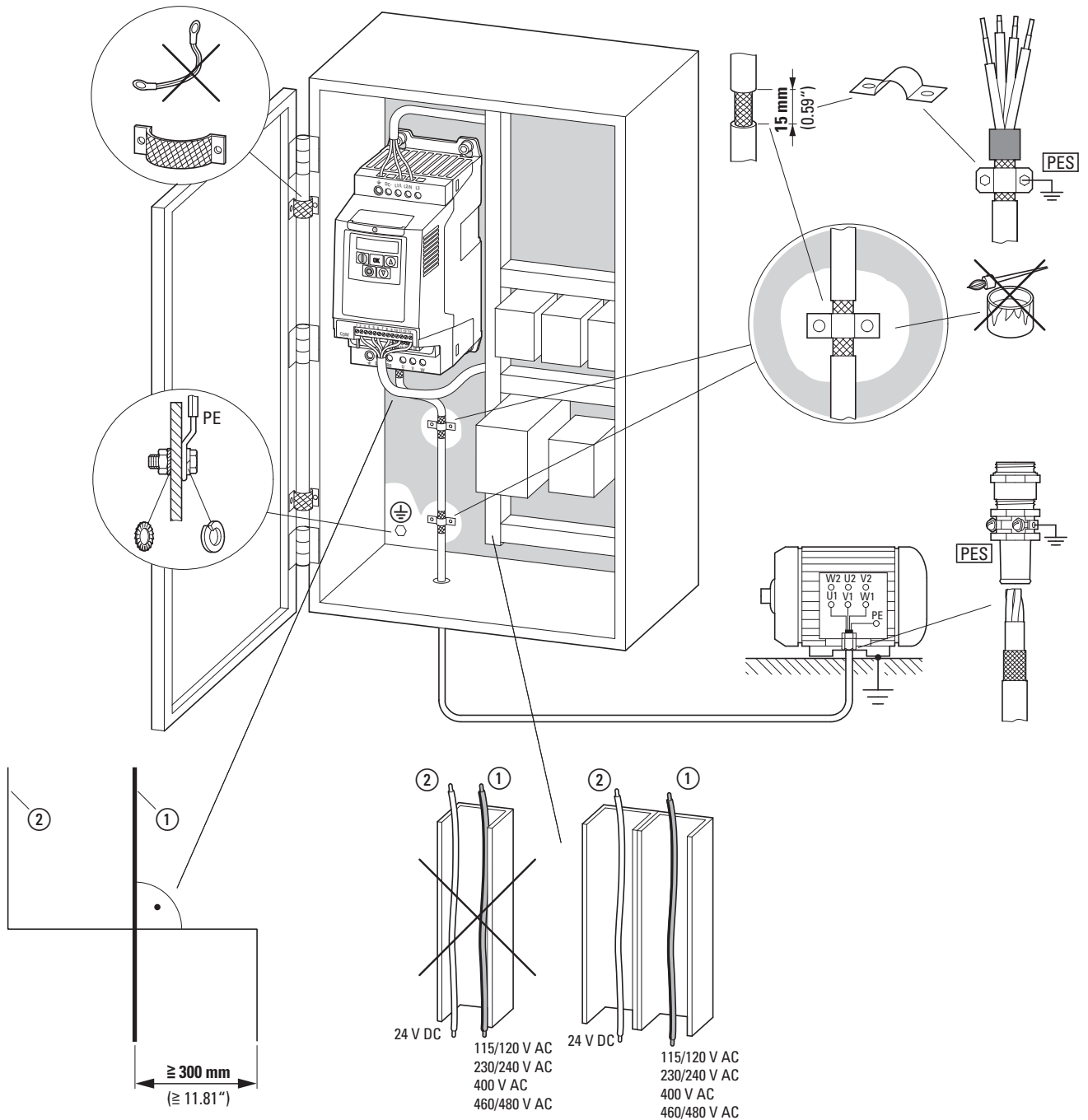

Figure 31: EMC-compliant surface mounting

① Power cable: mains voltage, motor connection, braking resistance

② Control and signal lines, fieldbus connections

Large-area connection of all metallic control panel components.

Mounting surfaces of variable frequency drive and cable screen must be free from paint.

Cable screen of cables at variable frequency drive's output with earth potential (PES) across large surface area

Large-area cable screen contacts with motor.

Large-area earth connection of all metallic parts.

3 Installation

3.4 Electrical Installation

3.4 Electrical Installation



CAUTION

Carry out the wiring work only after the variable frequency drive has been correctly mounted and secured.



DANGER

Electric shock hazard - risk of injuries!
Carry out wiring work only if the unit is de-energized.

NOTICE

Fire hazard!
Only use cables, protective switches, and contactors that feature the indicated permissible nominal current value.

NOTICE

In DA1 variable frequency drives, earth leakage currents are greater than 3.5 mA (AC). According to product standard IEC/EN 61800-5-1, an additional equipment grounding conductor must be connected, or the cross-section of the equipment grounding conductor must be at least 10 mm².



DANGER

The components in the variable frequency drive's power section remain energized up to five (5) minutes after the supply voltage has been switched off (intermediate circuit capacitor discharging time).

Pay attention to hazard warnings!



Complete the following steps with the specified tools and without using force.

3.4.1 Power section connections

The connection to the power section is normally made via the connection terminals:

- L1/L, L2/N, L3, PE for the mains-side supply voltage.
The phase sequence does not matter.
- DC+, DC-, PE for DC voltage supplies
- U, V, W, PE for the input wiring to the motor
- BR, DC+ for an external braking resistance

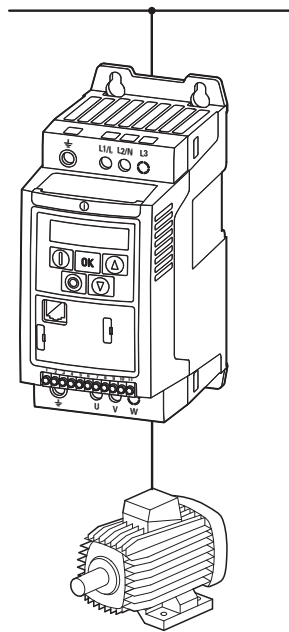

Figure 32: Connection in power section (schematic)

The number and the arrangement of the connection terminals used depend on the variable frequency drive's size and model.

NOTICE

The variable frequency drive must always be connected with ground potential via a grounding conductor (PE).

3 Installation

3.4 Electrical Installation

3.4.1.1 connection cables

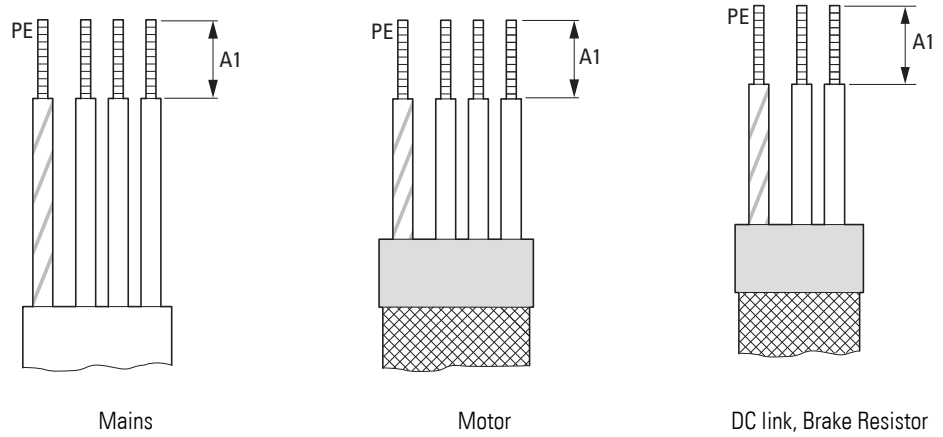

Figure 33: connection cables

Table 5: Stripping lengths in the power section

Size	A1 mm (in)
FS2	8 (0.3)
FS3	8 (0.3)
FS4	–
FS5	–
FS6	–
FS7	–

Mains = Electrical supply system,
 Motor = Motor connection,
 DC-Link = Internal DC link,
 Brake Resistor = Braking resistance

3.4.1.2 Terminals in power section

Table 6: Terminations

Frame size	Terminations	Description
FS2 FS3 FS4 FS5 FS6 FS7		Connection with single-phase supply voltage: <ul style="list-style-type: none"> • DA1-12... (230 V)
		Connection with three-phase supply voltage: <ul style="list-style-type: none"> • DA1-32... (230 V) • DA1-34... (400 V, 480 V)
		Motor connection for three-phase motors: <ul style="list-style-type: none"> • DA1-12... (230 V) • DA1-32... (230 V) • DA1-34... (400 V, 460 V) optional: External braking resistance (R_B)



In sizes FS2 and FS3, the DC+, DC-, and BR terminals are covered with plastic covers at the factory. They can be uncovered if necessary.

In all single-phase supply variable frequency drives terminal L3 is covered with a plastic cover. Do not uncover this terminal!

3.4.1.3 connection cables

The screened cables between the variable frequency drive and the motor should be as short as possible.

- ▶ Connect the screening, on both sides and across a large area (360° overlap), to the protective earth (PE) (⊕). The power screening's protective earth (PES) connection should be in the immediate proximity of the variable frequency drive and directly on the motor terminal box.
- ▶ Prevent the screening from becoming unbraided, e.g. by pushing the opened plastic sheath over the end of the screening or with a rubber grommet on the end of the screening. As an alternative, in addition to a broad area cable clip, you can also twist the shielding braid at the end

3 Installation

3.4 Electrical Installation

and connect to protective ground with a cable clip. To prevent EMC disturbance, this twisted shielding connection should be made as short as possible (→ Figure 35).

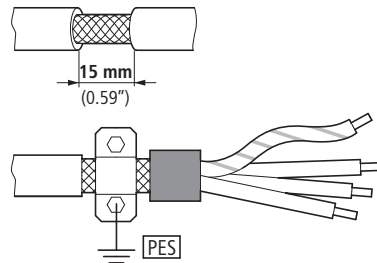

Figure 34: Screenshot of a screened connection cable

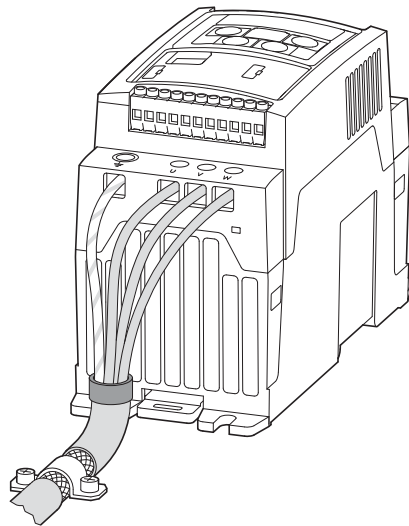

Figure 35: Connection with twisted cable screen
Recommended value for twisted cable shielding:
 $b \geq 1/5 a$

Screened, four-wire cable is recommended for the motor cables. The green-yellow line of this cable connects the protective ground connections from the motor and the variable frequency drive and therefore minimizes the equalizing current loads on the shielding braid.

The following figure shows the construction of a four-wire, screened motor line (recommended specifications).

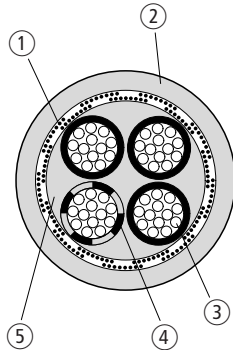

Figure 36: Four-core screened motor supply cable

- ① Cu shield braid
- ② PVC outer casing
- ③ Drain wire (copper strands)
- ④ PVC core insulation, 3 x black, 1 x green–yellow
- ⑤ Textile and PVC fillers

If there are additional subassemblies in a motor feeder (such as motor contactors, overload relays, motor reactor, sinusoidal filters or terminals), the shielding of the motor cable can be interrupted close to these subassemblies and connected to the mounting plate (PES) with a large area connection. Free or non-screened connection cables should not be any longer than about 300 mm.

3.4.1.4 Configuration and terminal capacities

The connection terminals' layout depends on the size of the power section. The cross-sections to be used in the connections and the tightening torques for screws are listed in the following.

Table 7: Cross-sectional areas and tightening torques

Size	mm ²	AWG	MM	in	N/m	MM
FS2 ... FS7	0.2 - 2.5	24 - 12	8	0.31	0.5	0.6 x 3.5

3 Installation

3.4 Electrical Installation

3.4.2 Connection on control section

The 13-terminal and 5-terminal strips have a plug-in design and are mounted in the front.

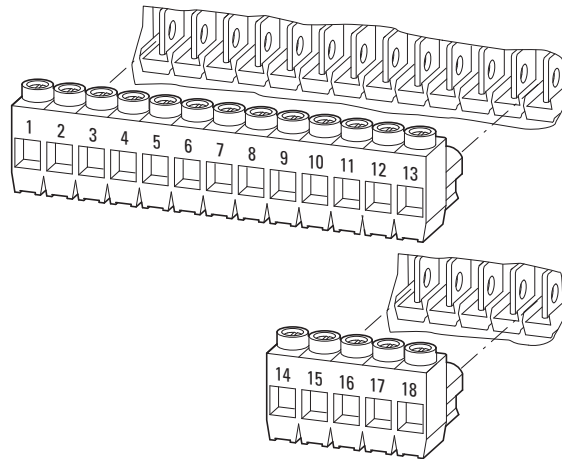

Figure 37: Location of plug-in control signal terminals

The control cables should be screened and twisted. The screening is applied on one side in the proximity of the variable frequency drive (PES).



Prevent the screening from becoming unbraided, i.e. by pushing the separated plastic covering over the end of the shielding or with a rubber grommet on the end of the screening.

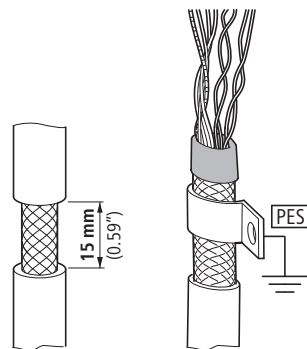

Figure 38: Preventing the screening from becoming unbraided

Alternatively, in addition to the broad area cable clip, you can also twist the shielding braid at the end and connect to the protective ground with a cable lug. To prevent EMC disturbance, this twisted shielding connection should be made as short as possible (→ Figure 35, page 62).

Prevent the screen from becoming unbraided at the other end of the control cable, e.g. by using a rubber grommet. The shield braid must not make any connection with the protective ground here because this would cause problems with an interference loop.

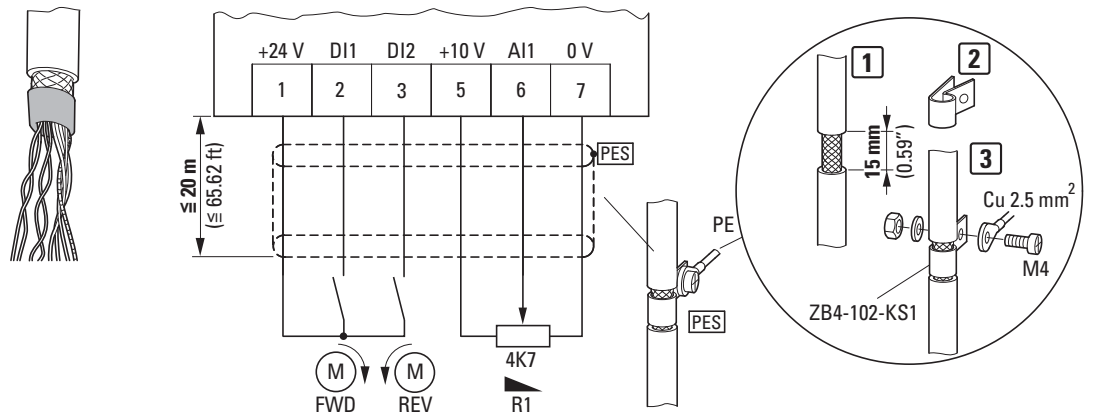

Figure 39: Example for an insulated end of the control cable

3.4.2.1 Arrangement and designation of the control signal terminals



ESD measures

Discharge yourself on a grounded surface before touching the control signal terminals and the circuit board to prevent damage through electrostatic discharge.

The following figure shows the layout and designations for the DA1 variable frequency drive's control signal terminals.

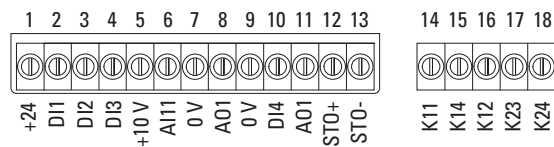

Figure 40: Arrangement and factory designations for the control signal terminals

3 Installation

3.4 Electrical Installation

3.4.2.2 Functions of control signal terminals

The functions that are set in the ex-factory and the electrical connection data of control signal terminals are listed in the following table.

Table 8: Factory-set functions of the control terminals

Terminal	Signal	Description	Default settings
1	+24 V	Control voltage for DI1 - DI5, output (+24 V)	–
2	DI1	Digital input 1	Start enable FWD ¹⁾
3	DI2	Digital Input 2	Start enable REV ¹⁾
4	DI3	Digital Input 3	Fixed frequency FF1/FF2 ¹⁾
5	+10 V	Reference voltage, Output (+10 V)	–
6	AI1 DI4	Analog input 1 Digital Input 5	Frequency reference value ¹⁾
7	0 V	Reference potential	–
8	AO1 DO1	Analog output 1 Digital output 1	Output frequency ¹⁾
9	0 V	Reference potential	–
10	DI4 AI2	Digital Input 4 Analog input 2	Fixed frequency FF2 ¹⁾
11	AO2 DO2	Analog output 2 Digital output 2	Output current ¹⁾
12	STO+	Safe Torque Off +	–
13	STO-	Safe Torque Off -	–
14	K11	Relay 1, changeover contact	active = FAULT ¹⁾
15	K14	Relay 1, changeover contact (N/O)	active = FAULT ¹⁾
16	K12	Relay 1, changeover contact (N/C)	active = FAULT ¹⁾
17	K23	Relay 2, N/O contact	active = FAULT ¹⁾
18	K24	Relay 2, N/O contact	active = FAULT ¹⁾

1) programmable function

The DA1 variable frequency drive has four control inputs (control signal terminals 2, 3, 4, 6 and 10). Three of these are permanently set as digital control inputs; while the others can be set to work as digital or analog control inputs.

The variable frequency drive comes with the following default setting:

- Control signal terminal 2 as digital input 1 (DI1),
- Control signal terminal 3 as digital input 2 (DI2),
- Control signal terminal 4 as digital input 3 (DI3),
- Control signal terminal 6 as analog input 1 (AI1).
- Control signal terminal 10 as digital input 4 (DI4),

Control signal terminals 8 and 11 can be used as digital or analog outputs. They are set up as analog outputs (AO) in the default configuration that comes with the variable frequency drive when it is delivered.

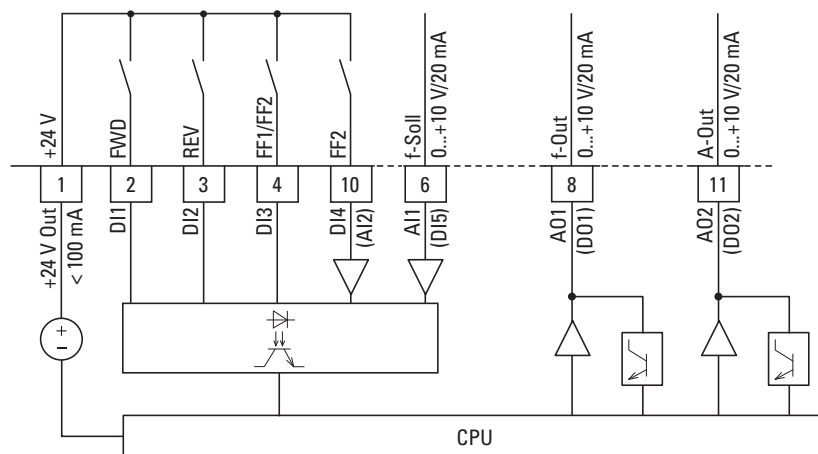

Figure 41: Control signal terminals (digital / analog)

3 Installation

3.4 Electrical Installation

3.4.2.3 Analog input signals

Depending on how parameters P1-12 and P1-13 are set, control signal terminals 6 (AI1) and 10 (AI2) can be connected to analog signals.

- 0 - +10 V
- 0 - 10 V with scaling and operating direction change
- 0 - 20 mA
- 4 - 20 mA or 20 - 4 mA with open-circuit monitoring (< 3 mA)



The assignments between the values and functions are described in → Section 6.2.2, "Analog Input (AI)", page 136.



Control signal terminals 7 and 9 are the common 0 V reference potential for all analog and digital input signals.

3.4.2.4 Analog output signal

An analog signal is available at control signal terminals 8 and 11. These outputs can handle a maximum load of 20 mA. The output signal is configured using parameters P2-11 (AO1) and P2-13 (AO2) (→ Table 10, Page 87).

Parameters P2-12 (AO1) and P2-14 (AO2) are used to configure the formats for the analog inputs:

Parameter value	Configuration
0	0 - 10 V
1	10 - 0 V
2	0 - 20 mA
3	20 - 0 mA
4	4 - 20 mA
5	20 - 4 mA

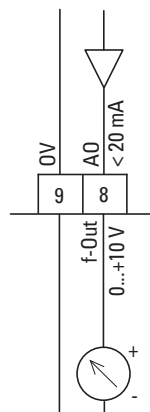

Figure 42: Analog output (AO) (connecting example)



Control signal terminals 7 and 9 are the common 0 V reference potential for all analog and digital output signals.

3.4.2.5 Digital Input Signals

Control signal terminals 2, 3, 4, 6 and 10 all have the same function and mode of operation as digital inputs (DI1 to DI5).

A logic level of +24 V (positive logic) is used:

- 8 - +30 V = High (logic "1")
- 0 - +4 V = Low (logic "0")

The internal control voltage from control terminal 1 (+24 V, maximum 100 mA) or an external voltage source (+24 V) can be used for this. The permissible residual ripple must be less than $\pm 5\% \Delta U_a / U_a$.

The parameter configuration and the way functions are assigned are described in → Section 6.2.1, "Digital Input (DI)", page 135.



Control signal terminals 7 and 9 are the common 0 V reference potential for all analog and digital input signals.

3 Installation

3.4 Electrical Installation

3.4.2.6 Digital output (Transistor)

Control signal terminals 8 and 11 are set up as analog outputs (AO) in the default configuration that comes with the variable frequency drive when it is delivered. Parameters P2-11 and P2-13 (→ Table 10, Page 87) can be used to set them up as digital outputs (DO) instead.

Transistor outputs DO1 and DO2 can deliver a digital signal via control signal terminals 8 and 11 using the device's internal control voltage (+24 V). The maximum permissible load current is 20 mA.

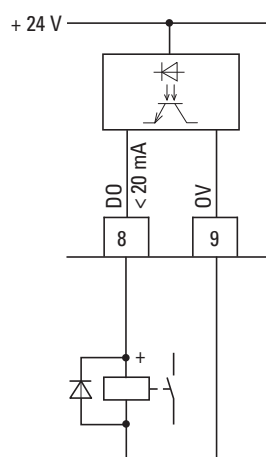

Figure 43: Connection example (interposing relay with free-wheeling diode: ETS4-VS3; article no. 083094)



Control signal terminals 7 and 9 are the common 0 V reference potential for all analog and digital output signals.

3.4.2.7 Digital Output (Relay)

Control signal terminals 14, 15 (N/O), and 16 (N/C) are connected to the DA1 variable frequency drive's internal relay 1 in a potential-free manner.

Control signal terminals 17 and 18 are connected to internal relay 2 (N/O) in a potential-free manner.

The relay function can be configured using parameters P2-15 and P2-18 (→ Table 10, Page 87).

The electrical connection specifications for control signal terminals are:

- 250 V AC, max. 6 A
- 30 V DC, max. 5 A

We recommend connecting any connected loads as follows:

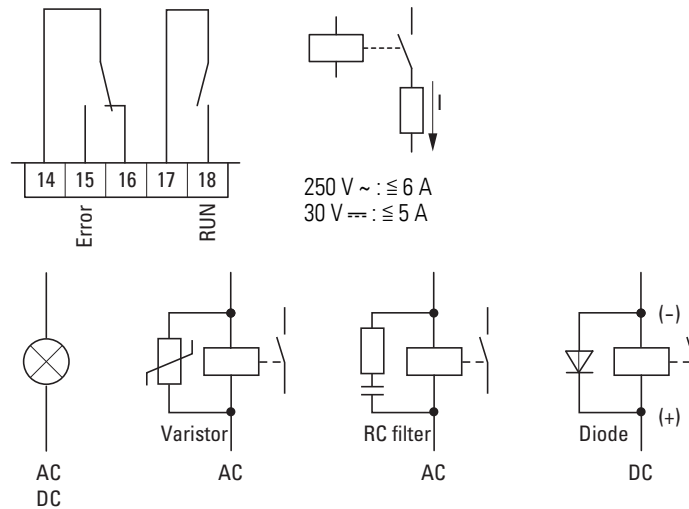

Figure 44: Connection examples with suppressor circuit

3.4.2.8 RJ 45 interface

The RJ45 port located on the bottom part of the DA1 variable frequency drive makes it possible to connect directly to communication modules and fieldbus connections.

The internal RS485 connection handles transmissions for the OP bus, Modbus RTU, and CANopen field bus systems.

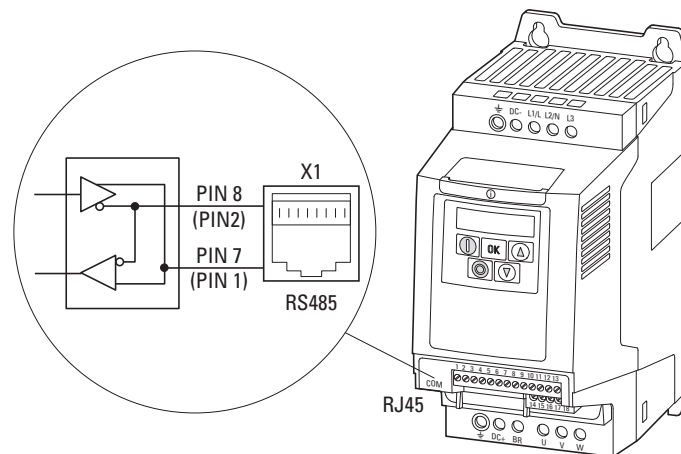

Figure 45: RJ45 port on DA1 variable frequency drive



DA1 variable frequency drives do not have an internal bus termination resistor.
Use DX-CBL-TERM if necessary.

3 Installation

3.4 Electrical Installation

3.4.3 Block diagrams

The following block diagrams show all the connection terminals on a DA1 variable frequency drive and their functions when in their default settings.

3.4.3.1 DA1-12...

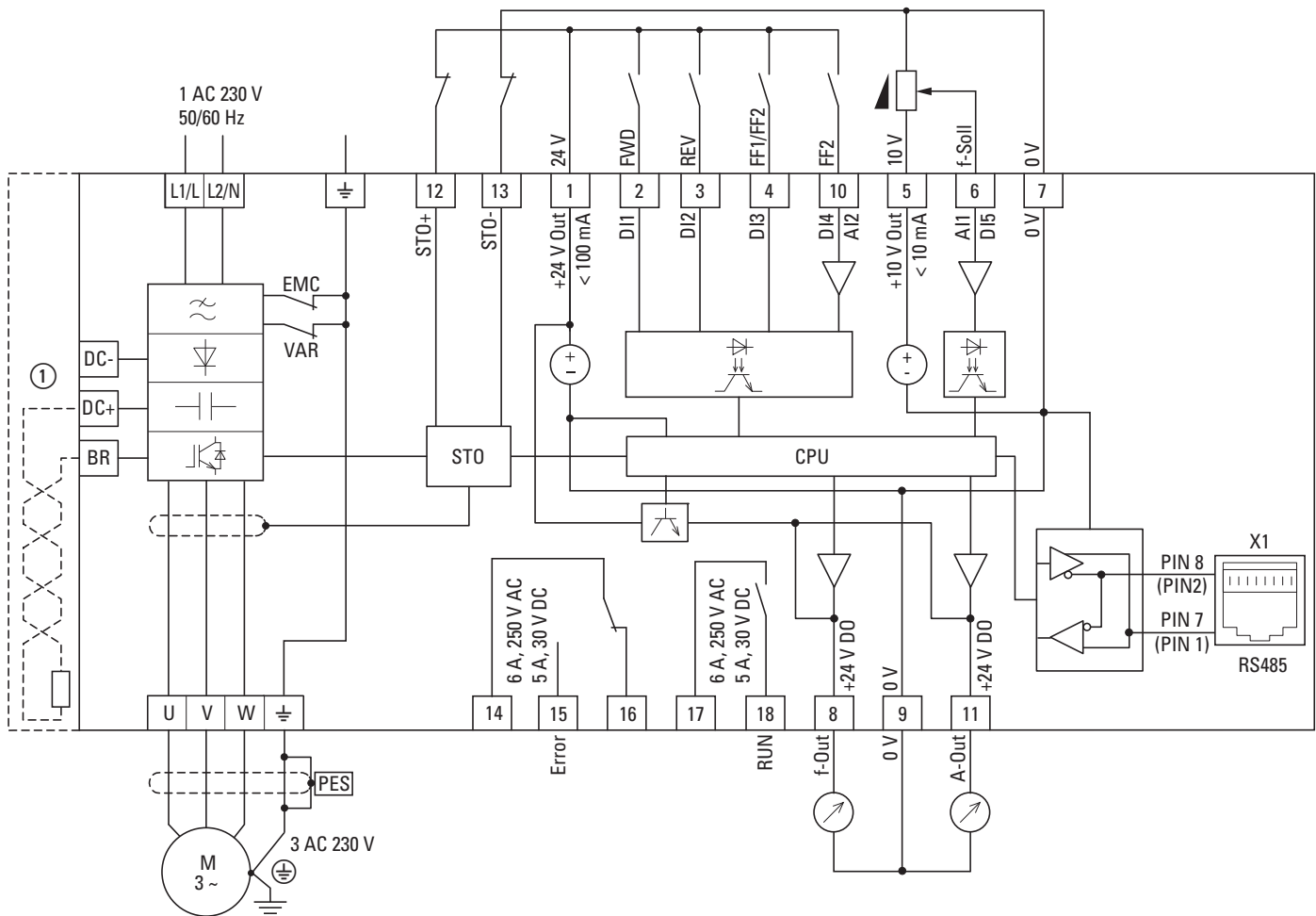

Figure 46: DA1-12... block diagram
Variable frequency drive with single-phase supply system voltage and three-phase motor connection

① External braking resistors can be connected to devices of size FS2 to FS8.

3.4.3.2 DA1-32..., DA1-34...

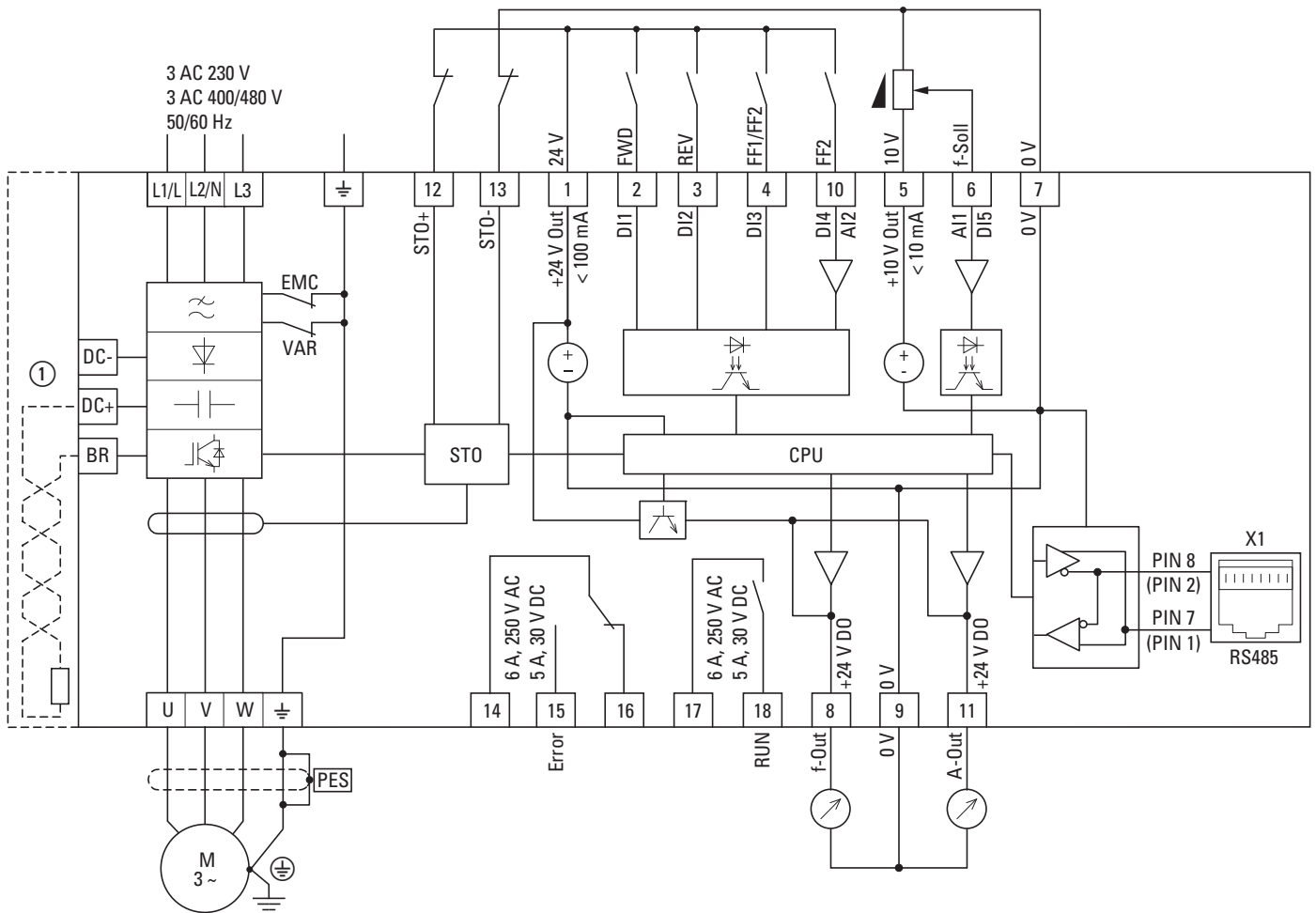

Figure 47: DA1-32..., DA1-34... block diagram
Variable frequency drive with three-phase mains supply voltage and three-phase motor connection

① External braking resistors can be connected to devices of size FS2 to FS8.

3 Installation

3.4 Electrical Installation

3.4.4 Insulation test

The variable frequency drive of the DA1 series are tested, delivered and require no additional testing.



CAUTION

On the control signal and the connection terminals of the variable frequency drive, no leakage resistance tests are to be performed with an insulation tester.



CAUTION

Wait at least 5 minutes after switching the supply voltage off before you disconnect one of the connection terminals (L1/L, L2/N, L3, DC-, DC+, BR) of the variable frequency drive.

If insulation testing is required in the power circuit of the PDS, you must consider the following measures.

3.4.4.1 Testing the motor cable insulation

- ▶ Disconnect the motor cable from the connection terminals U, V and W of the variable frequency drive and from the motor (U, V, W). Measure the insulation resistance of the motor cable between the individual phase conductors and between the phase conductor and the protective conductor.

The insulation resistance must be greater than 1 MΩ.

3.4.4.2 Testing the mains cable insulation

- ▶ Disconnect the power cable from the mains supply network and from the connection terminals 1/L, L2/N and L3 of the variable frequency drive. Measure the insulation resistance of the mains cable between the individual phase conductors and between each phase conductor and the protective conductor.

The insulation resistance must be greater than 1 MΩ.

3.4.4.3 Testing the motor insulation

- ▶ Disconnect the motor cable from the motor (U, V, W) and open the bridge circuits (star or delta) in the motor terminal box. Measure the insulation resistance of the individual motor windings. The measurement voltage must at least match the rated operating voltage of the motor but is not to exceed 1000 V.

The insulation resistance must be greater than 1 MΩ.



Consider the notes from the motor manufacturer in testing the insulation resistance.

4 Operation

4.1 Checklist for commissioning

Before placing the variable frequency drive into operation, use the checklist below to make sure that all the following requirements are met:

No.	Activity	Notes
1	Mounting and wiring have been carried out in accordance with the corresponding instructional leaflet (→ IL04020015Z, IL04020011Z, IL04020012Z, IL04020010Z).	
2	All wiring and line section leftovers, as well as all the tools used, have been removed from the variable frequency drive's proximity.	
3	All terminals in the power section and in the control section were tightened with the specified torque.	
4	The lines connected to the output terminals (U, V, W, DC+, DC-, BR) of the variable frequency drive are not short-circuited and are not connected to ground (PE).	
5	The variable frequency drive has been earthed properly (PE).	
6	All electrical terminals in the power section (L1/L, L2/N, L3, U, V, W, DC+, DC-, BR, PE) were implemented properly and were designed in line with the corresponding requirements.	
7	Each single phase of the supply voltage (L or L1, L2, L3) is protected with a fuse.	
8	The variable frequency drive and the motor are adapted to the mains voltage. (→ Section 1.4.1, "Rating data on the nameplate", page13, connection type (star, delta) of the motor tested).	
9	The quality and volume of cooling air are in line with the environmental conditions required for the variable frequency drive and the motor.	
10	All connected control cables comply with the corresponding stop conditions (e.g., switch in OFF position and set-point value= zero).	
11	The parameters that were preset at the factory have been checked with the list of parameters (Table 10, page 87).	
12	The effective direction of a coupled machine will allow the motor to start.	
13	All emergency switching off functions and safety functions are in an appropriate condition.	

4 Operation

4.2 Hazard warnings for operation

4.2 Hazard warnings for operation

Please observe the following notes.



DANGER

Commissioning is only to be completed by qualified technicians.



DANGER

Hazardous voltage!

The safety instructions on pages I and II must be followed.



DANGER

The components in the variable frequency drive's power section are energized if the supply voltage (mains voltage) is connected. For instance: L1/L, L2/N, L3, DC+, DC-, BR, U/T1, V/T2, W/T3 power terminals.

The control signal terminals are isolated from the line power potential.

There can be a dangerous voltage on the relay terminals (10, 11) even if the variable frequency drive is not being supplied with mains voltage (e.g., integration of relay contacts in control systems with voltage > 48 V AC / 60 V DC).



DANGER

The components in the variable frequency drive's power section remain energized up to five (5) minutes after the supply voltage has been switched off (intermediate circuit capacitor discharging time).

Pay attention to hazard warnings!



DANGER

Following a shutdown (fault, mains voltage off), the motor can start automatically (when the supply voltage is switched back on) if the automatic restart function has been enabled (→ parameters P2-36).

4.3 Commissioning with control signal terminals (default settings)

NOTICE

Any contactors and switchgear on the power side are not to be opened during motor operation. Inching operation using the power switch is not permitted.

Contactors and switchgear (repair and maintenance switches) on the motor side must not be opened while the motor is in operation.

Inching operation of the motor with contactors and switchgear in the output of the variable frequency drive is not permitted.

NOTICE

Make sure that there is no danger in starting the motor. Disconnect the driven machine if there is a danger in an incorrect operating state.



If motors are to be operated with frequencies higher than the standard 50 or 60 Hz, then these operating ranges must be approved by the motor manufacturer. The motors could be damaged otherwise.

4.3 Commissioning with control signal terminals (default settings)

DA1 variable frequency drives are set in the factory and can be started directly via the control signal terminals by connecting the motor outputs allocated for the mains voltage (see connection example below).



You can skip this section if you want to set up the parameters directly for optimal operation of the variable frequency drive based on the motor data (rating plate) and the application.

Following are a series of simplified connecting examples that use the default settings.

4 Operation

4.3 Commissioning with control signal terminals (default settings)

Connecting example for three-phase motor

Connecting example for three-phase motor	Terminal	designation	
	L1/L	Single-phase power supply connection (DA1-12...)	
	L2/N		Three-phase power supply connection (DA1-32..., DA1-34...)
	L3		
	⊕	Ground connection	
	1	Control voltage +24 V (output, maximum 100 mA)	
	2	FWD, Start release clockwise rotating field	
	3	REV, Start release left rotating field	
	U	Connection for three-phase ac motor (three-phase motor)	
	V		
	W		
	⊕		
	5	Setpoint value voltage +10 V (Output, maximum 10 mA)	
	6	Frequency reference value f-Set (Input 0 – +10 V)	
7	Reference potential (0 V)		
12	Safe Torque Off +		
13	Safe Torque Off -		

- ▶ Connect the variable frequency drive according to the connecting example above for the simple commissioning with the specified default settings (see connecting example above).

The potentiometer should have a fixed resistance (connection to control signal terminals 5 and 7) of at least 1 k Ω , up to a maximum of 10 k Ω . A standard fixed resistance of 4.7 k Ω is recommended.

Make sure that the enable contacts (FWD/REV) are open and the STO is connected correctly before switching on the mains voltage.



If the connections for the setpoint value potentiometer cannot be clearly allocated with terminals 5, 6 and 7, you should set the potentiometer to about 50 % before giving the start release (FWD/REV) for the first time.

When the specified supply voltage is applied at the mains connection terminals (L1/L, L2/N, L3), the switched-mode power supply unit (SMPS) in the internal DC link will be used to generate the control voltage and light up the 7-segment LED display (STOP).

At this point, the variable frequency drive will be ready for operation (correct operating status) and in Stop mode.

4.3 Commissioning with control signal terminals (default settings)

The start release is done by actuating one of the digital inputs with +24 V:

- Terminal 2: FWD = Clockwise rotating field (Forward Run)
- Terminal 3: REV = Counterclockwise rotating field (Reverse Run)

The FWD and REV control commands are interlocked (exclusive OR) and require a rising voltage edge.

The frequency is shown with a minus sign with a start release with a left rotating field (REV).

- You can now set the output frequency (0 - 50 Hz) and, as a result, the speed of the connected three-phase motor (0 - n_{Motor}) by using the potentiometer via terminal 6 (0 - +10 V proportional voltage signal). The change in output frequency here is delayed based on the specified acceleration and deceleration ramps. In the default settings, these times are set to 5 seconds and to 10 seconds from a frame size FS4.

The acceleration and deceleration ramps specify the time change for the output frequency: from 0 to f_{max} (WE = 50 Hz) or from f_{max} back to 0.

Figure 48 shows a good example of the process, if the release signal (FWD/REV) is switched on and the maximum setpoint voltage (+10 V) is applied. The speed of the motor follows the output frequency depending on the load and moment of inertia (slip), from zero to n_{max} .

If the release signal (FWD, REV) is switched off during operation, the inverter is blocked immediately (STOP). The motor comes to an uncontrolled stop (see ① in Figure 48). The acceleration time is set in parameter P1-03.

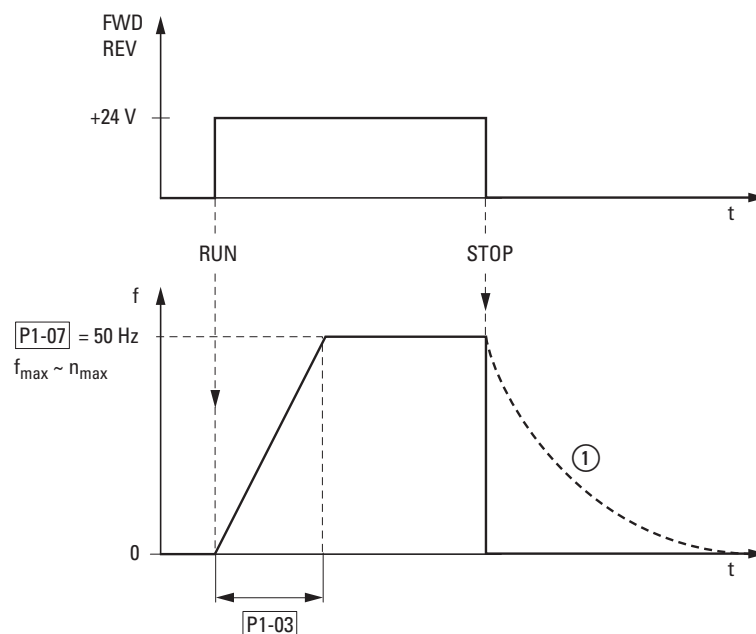

Figure 48: Start-Stop command with maximum setpoint value voltage

4 Operation

4.3 Commissioning with control signal terminals (default settings)

5 Error messages

5.1 Introduction

DA1 series variable frequency drives come with several internal monitoring functions. When a deviation from the correct operating state is detected, an error message will be displayed; in the inverter's default settings, the relay contact will open (control signal terminals 14 and 15).

5.1.1 Error messages

The most recent four error messages will be stored in the order in which they occurred (with the most recent one in the first place). Error messages can be read from parameter P0-13 and the P0-... monitor values.

5.1.2 Acknowledge fault (Reset)

To acknowledge and reset the current error message, you can either switch off the supply voltage or press the STOP pushbutton.

5.1.2.1 Fault log

The fault log (P0-13) stores the most recent four error messages in the order in which they occurred. The most recent error message will always be shown as the first value when P0-13 is accessed. To see the remaining error messages one after the other, press the ▲ (Up) button. Their order will be indicated by means of flashing dots in the 7-segment digital display assembly.











To get more information regarding the fault, go to the "Monitor" menu (P0-...).

The values in the fault log (P0-13) will not be deleted if the variable frequency drive is reset to its default settings!

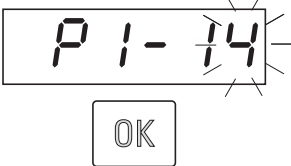
5 Error messages

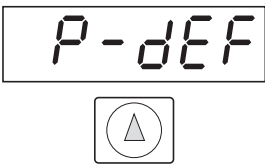
5.1 Introduction

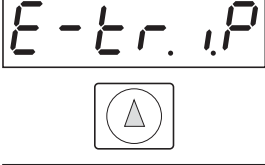
The example below shows how to access the fault log.

Indicator	Explanation
	<p>Operating state Stop</p> <p>Press OK button</p>
	<p>The parameter that was last accessed will be shown. The last digit on the display will flash.</p>
	<p>Use the ▲ (Up) or ▼ (Down) arrow key to select parameter P1-14 and confirm your selection by pressing the OK pushbutton. The last digit on the display will flash.</p>
	<p>Use the ▲ (Up) or ▼ (Down) arrow key to set a parameter value of 101 or 201 and confirm your selection by pressing the OK pushbutton.</p>
	<p>Use the ▲ (Up) or ▼ (Down) arrow keys to select parameter P0-13 and confirm your selection by pressing the OK pushbutton. The last digit on the display will flash.</p>
	<p>Last error message. Example: P-def (Parameter default = Default settings loaded).</p> <p>Use the arrow button ▲ (Up) to go to the next error message.</p>
	<p>Second most recent error message: Example: U-UoL.t (undervoltage message). The dot on the right will flash.</p> <p>The third most recent error message will be shown after pressing the ▲ arrow key (Up).</p>
	<p>Example: E-trip (external error message) The two dots on the right will flash.</p>
	<p>The oldest error message will be shown after you press the ▲ arrow key (Up) once more.</p> <p>Example: U-UoL.t (undervoltage message) The three dots on the right will flash.</p>

5.1.3 Error list

The following table lists the failure codes, the possible causes and indicates corrective measures.

Table 9: Error messages list

Indicator	Fault Code	Designation	Possible cause	Notes
<i>no-Flt</i>	00	no error	–	–
<i>Ob-b</i>	01	Overcurrent braking resistance	Brake chopper overcurrent	Overcurrent in braking resistor circuit Check the wiring to the braking resistance. Check the brake resistor value (P6-19). Make sure that the minimum resistance values are being adhered to.
<i>OL-br</i>	02	Braking resistor thermal overload	Braking resistance overload	Increase the deceleration time (P1-04), reduce the load's moment of inertia, or connect additional braking resistors in parallel. Make sure that the minimum resistance values are being adhered to.
<i>O-I</i>	03	Overcurrent motor	<ul style="list-style-type: none"> • Overcurrent at output • Motor overload • Overtemperature at heat sink 	<p>Motor with constant speed: Determine the overload or fault.</p> <p>Motor starts: The load stalled or has seized, or the brake is not open. Check whether there is a star/delta motor wiring error.</p> <p>Motor accelerates/decelerates: The excessively short acceleration/deceleration time is requiring too much power. If P1-03 or P1-04 cannot be increased, a more powerful variable frequency drive is required. Cable fault between variable frequency drive and motor.</p>
<i>ILT-ERP</i>	04	Thermal motor overload	The DA1 variable frequency drive was switched off after more than 100 % of the value set in P1-08 was delivered for a period of time.	<p>Check whether the decimal places are flashing (variable frequency drive overloaded) and either raise the acceleration ramp (P1-03) or reduce the motor load.</p> <p>Make sure that the cable length matches the variable frequency drive specifications. Check the load mechanically in order to make sure that it is free, that nothing is getting jammed or locked, and there are no other mechanical faults.</p>
<i>SAFE-I</i>	05	Safe Torque Off fault	Power supply at STO input interrupted	
<i>OVdL5</i>	06	Overvoltage DC link	Overvoltage at DC link	Power supply problem Increase the deceleration ramp time P-04.
<i>UVdL5</i>	07	DC link undervoltage	DC link undervoltage	Normally occurs if the power is switched off. If it occurs during running, check the power supply voltage.
<i>O-t</i>	08	Overtemperature	Heat sink overtemperature	Check the variable frequency drive's ambient air temperature. Check whether additional clearance or cooling is required.
<i>U-t</i>	09	Excessively low temperature (frost)	Heat sink undertemperature	The variable frequency drive will be switched off if the ambient temperature < -10 °C. Raise the temperature over -10 °C in order to start the variable frequency drive.

5 Error messages

5.1 Introduction

Indicator	Fault Code	Designation	Possible cause	Notes
<i>P-DEF</i>	10	Parameter default	The parameter's default setting has been loaded.	Press the STOP pushbutton. The DA1 variable frequency drive is ready for an application-specific configuration.
<i>E-ERRIP</i>	11	External fault	External shutdown (on digital input 3)	External safety shutdown on digital input 3. The normally-closed contact opened for some reason. If a motor thermistor is connected, check whether the motor is too hot.
<i>SC-DBS</i>	12	Communication fault	Communication loss error	Check the communications connection between the variable frequency drive and external devices. Make sure that each individual variable frequency drive on the network has a unique address.
<i>FLT-dc</i>	13	Large residual ripple in DC link	Excessively large residual ripple in DC link	Check to make sure that all three phases are present and have a voltage tolerance of less than 3 %. Reduce the motor load
<i>P-LOSS</i>	14	Mains connection phase fault	Shutdown caused by input phase loss	A variable frequency drive intended for use with a three-phase power supply has lost one of its input phases.
<i>hD-I</i>	15	Instantaneous motor over-current		
<i>th-FIL</i>	16	Thermistor fault	Defective thermistor on heat sink	Please contact your closest Eaton representative.
<i>ERR-F</i>	17	Data error	Internal memory error	Parameter not stored; default settings loaded back. If the problem occurs again, please contact your closest Eaton representative.
<i>4-ZDF</i>	18	Live zero error	Analog input current outside range	Make sure that the input current falls within the range defined by P-16.
<i>ERR-E</i>	19	Data error	Internal memory error	Parameter not stored; default settings loaded back. If the problem occurs again, please contact your closest Eaton representative.
<i>U-DEF</i>	20	User parameter default		
<i>F-Ptc</i>	21	Motor thermistor fault	Defective thermistor in motor	Reduce the load on the motor.
<i>FAN-F</i>	22	Internal fan fault	Internal fan fault	Check the internal fan and replace if necessary.
<i>hERRt</i>	23	Excessively high ambient temperature	Excessively high ambient temperature	Make sure that the internal fan is working. Reduce the pulse frequency (P2-24). Reduce the load on the motor. Make sure that hot air is not flowing into the variable frequency drive from surrounding devices.
<i>D-tor9</i>	24	Torque exceeded	Torque has exceeded the limit value	Reduce the load on the motor. Increase the acceleration time (P2-03).
<i>U-tor9</i>	25	Torque fallen below	Excessively low torque	Only visible if hoisting mode (P2-18 = 8) is enabled. Check the brake settings in the variable frequency drive.
<i>OUT-F</i>	26	Output fault	Fault at variable frequency drive output	
<i>SAFE-2</i>	29	Safe Torque Off fault	Power supply at STO input interrupted	

Indicator	Fault Code	Designation	Possible cause	Notes
<i>Enc - 01</i>	30	Encoder feedback error (visible only if the DXA-EXT-ENCOD encoder module is plugged in and fastened)	Communication fault	Communications and data errors
<i>Enc - 02</i>	31		Speed error	The difference between the measured speed and the calculated speed in the variable frequency drive is too large.
<i>Enc - 03</i>	32		Incorrect PPRs configured	
<i>Enc - 04</i>	33		Channel A fault	Channel A is faulty.
<i>Enc - 05</i>	34		Channel B fault	Channel B is faulty.
<i>Enc - 06</i>	35		Channel A and B fault	Channels A and b are faulty.
<i>REF - 01</i>	40	Auto-tune error	Winding resistance error	The winding resistance varies between the individual windings. Check the motor's wiring.
<i>REF - 02</i>	41		Winding resistance error	The winding resistance is too high. Check the motor's wiring. Use the motor output to check whether the motor and the variable frequency drive are compatible.
<i>REF - 03</i>	42		Motor inductance error	The motor inductance is too low. Check the motor's wiring.
<i>REF - 04</i>	43		Motor inductance error	The motor inductance is too high. Check the motor's wiring. Use the motor output to check whether the motor and the variable frequency drive are compatible.
<i>REF - 05</i>	44		Motor data error	The measured motor data does not match. Check the motor's wiring. Use the motor output to check whether the motor and the variable frequency drive are compatible.
<i>Out - Ph</i>	49	Motor connection phase fault	Motor phase fault	An output phase is not connected to the motor. Check the motor's wiring. Use the motor output to check whether the motor and the variable frequency drive are compatible.
<i>Sc - E01</i>	50	Modbus communications error		Increase P5-06 to an appropriate value. Check whether the PLC is still running. Check the cable connections.
<i>Sc - E02</i>	51	Communication fault CANopen	A CANopen frame was not received within the time set in P5-06.	Increase P5-06 to an appropriate value. Check whether the PLC is still running. Check the cable connections.
<i>Sc - E03</i>	52	Plug-in module (field bus) communications error	Internal loss of communications between variable frequency drive and optional module	Check to make sure that the module is plugged in correctly.
<i>Sc - E04</i>	53	I/O plug-in module communications error	Internal loss of communications between variable frequency drive and optional module	Check to make sure that the module is plugged in correctly.

5 Error messages

5.1 Introduction

6 Parameters



When first switching on or after activating the default settings parameter P1-14 must be set to 201 for access to all parameters.

Table 10: Description list for DA1 parameters

PNU	ID	Access right		Value	Description	DS
		RUN	ro/rw			
Parameter group P1 – quick-start						
P1-01	129	✓	rw		Maximum frequency / maximum speed P1-10 = 0 → P1-02 - 5 x P1-09 → Hz P1-10 > 0 → P1-02 - 5 x P1-09 x 60 s → rpm The maximum output frequency / motor speed limit in Hz or rpm. If P-10 > 0, the value entered / displayed will be shown in rpm.	50.0
P1-02	102	✓	rw		Minimum frequency / minimum speed P1-10 = 0 → 0 - P1-01 → Hz P1-10 > 0 → 0 - P1-01 → rpm The minimum output frequency / minimum speed limit in Hz or rpm. If P-10 > 0, the value entered / displayed will be shown in rpm.	0
P1-03	103	✓	rw		Acceleration time (acc1) 0.1 - 600 s	5 (10 from FS4)
P1-04	104	✓	rw		Deceleration time (dec1) 0.1 - 600 s	5 (10 from FS4)
P1-05		✓	rw		Stop Function	1
				0	Ramp, deceleration = Regenerative braking. Deceleration time with the value set under P1-04 (dec1). If the energy that is fed back by the motor during the dynamic braking is too high, the deceleration time has to be extended. In devices with an internal braking transistor, the excess energy can be dissipated with an external braking resistance (optional)	
				1	Free coasting = After the start enable (FWD/REV) is switched off or the STOP pushbutton is pressed (P1-12 and P1-13), the motor will coast uncontrolled.	
				2	Ramp, quick stop = regenerative braking. Deceleration time 2 with the value set under P2-25 (dec2). If the energy that is fed back by the motor during the dynamic braking is too high, the deceleration time has to be extended. In devices with an internal braking transistor, the excess energy can be dissipated with an external braking resistor (optional).	

6 Parameters

PNU	ID	Access right		Value	Description	DS
		RUN	ro/rw			
				3	Free coasting, with activated braking chopper = After the start enable (FWD/REV) is switched off or the STOP pushbutton is pressed (P1-12 and P1-13), the motor will coast uncontrolled. If the energy that is fed back by the motor during the dynamic braking is too high, the deceleration time has to be extended. In devices with an internal braking transistor, the excess energy can be dissipated with an external braking resistor (optional).	
P1-06	106	✓	rw		Energy optimization	0
				0	Deactivated	
				1	Activated If it is selected, the energy optimization function will attempt to reduce the total energy consumed by the variable frequency drive and the motor during operation at constant speeds and with light loads. The output voltage applied at the motor will be reduced. The energy optimization function is intended for applications in which the variable frequency drive is run for specific periods at a constant speed and with a light load, independently of whether the torque is constant or varies.	
P1-07	107	–	rw		Nominal voltage of the motor	230 ¹⁾
					Setting range: 0. 20 - 250 / 500 V (→ Motor ratings plate) Pay attention to the supply voltage and the type of circuit in the stator winding! Note: This parameter value has a direct influence on the V/f characteristic curve (e.g. operation with 87 Hz characteristic curve). This must be especially taken into account in the case of values (P1-07) that deviate from the variable frequency drive's rated operational data ($U_{LN} = 100\%$). This may cause the over-excitation of the motor and thus lead to an increased thermal load.	
P1-08	108	–	rw		Rated motor current	4.8 ¹⁾
					Setting range: $0.2 \times I_e - I_e$ [A] (→ Motor rating plate) I_e = Variable frequency drive's rated operational current	
P1-09	109	–	rw		Nominal frequency of the motor	50.0 ¹⁾
					Setting range: 25 - 500 Hz (→ Motor rating plate) Note: This parameter value is also automatically applied as the cut-off frequency for the V/Hz characteristic curve.	

PNU	ID	Access right		Value	Description	DS
		RUN	ro/rw			
P1-10	110	✓	rw		Nominal speed of the motor 0 - 30000 rpm (→ motor rating plate)	0
					<p>Note: This parameter can be optionally set to the motor's rated speed (revolutions per minute, rating plate). If it is set to the factory default setting of 0, all speed-related parameters will be shown in Hz; slip compensation for the motor will be disabled. Entering the value on the motor's rating plate will enable the slip compensation function, and the variable frequency drive's display will show the motor speed in the estimated rpm. All speed-related parameters (such as the minimum and maximum frequencies and the fixed frequencies) will also be shown in rpm.</p>	
P1-11	111	–	rw		Output voltage at zero frequency 0.00 - 20.0 %	3.0
					<p>Voltage amplification is used in order to increase the motor voltage applied at low output frequencies so as to improve the torque at low speeds, as well as the starting torque.</p> <p>Note: A high start voltage enables a high torque at the start.</p> <p>Notice: A high torque at low speed causes a high thermal load on the motor. If temperatures are too high, the motor should be equipped with an external fan.</p>	
P1-12	140	–	rw		Control level	0
				0	Control signal terminals (I/O) The variable frequency drive will respond directly to signals applied to the control signal terminals.	
				1	Keypad (KEYPAD FWD) The variable frequency drive can only be controlled in the forward direction if an external or remote control keypad is used.	
				2	Keypad (KEYPAD FWD/REV) The variable frequency drive can be controlled in both the forward and reverse directions by using an external or remote control keypad. Pressing the START pushbutton will toggle between the forward and reverse directions.	
				3	PID controller The output frequency will be controlled by the internal PID controller.	
				4	Field bus Control via Modbus RTU (RS485) interface or optional fieldbus connection (e.g., PROFIBUS DP).	
				5	Slave mode The variable frequency drive will run in slave mode; in this mode, the output frequency will depend on the master variable frequency drive and can only be changed there. The variable frequency drives are connected to each other using the variable frequency drive's RJ45 interface.	
6	Field bus (CANopen) via RJ45 interface					

6 Parameters

PNU	ID	Access right		Value	Description	DS
		RUN	ro/rw			
P1-13	113	–	ro		Digital input (analog input) function	
P1-14	114	✓	rw		Parameter range access code	0
					(Depends on P2-40 or P6-30 Extended parameter access code)	
					Set the value to 101 (default setting) to enable access to the extended parameter menu. Modify via P2-40. To enable access to all parameters, set the value to 201. Change using P6-30.	

Extended parameter range Level 2 (access: P1-14 = 101 or P1-14 = 201)

Parameter group P2 - functions

P2-01	201	✓	rw		Fixed frequency FF1 / speed 1	5.0
					P1-10 = 0 → -P1-02 - P1-01 → Hz P1-10 > 0 → -P1-02 - P1-01 x 60 s → rpm (1/min) 0.00 Hz (P1-02) up to the maximum frequency value (P1-01). Activation via digital inputs depending on parameters P1-12 and P1-13 according to the "Input value DA1" table.	
P2-02	202	✓	rw		Fixed frequency FF2 / speed 2	10.0
					P1-10 = 0 → -P1-02 - P1-01 → Hz P1-10 > 0 → -P1-02 - P1-01 x 60 s → rpm (1/min) 0.00 Hz (P1-02) up to the maximum frequency value (P1-01). Activation via digital inputs depending on parameters P1-12 and P1-13.	
P2-03	203	✓	rw		Fixed frequency FF3 / speed 3	25.0
					P1-10 = 0 → -P1-02 - P1-01 → Hz P1-10 > 0 → -P1-02 - P1-01 x 60 s → rpm (1/min) 0.00 Hz (P1-02) up to the maximum frequency value (P1-01). Activation via digital inputs depending on parameters P1-12 and P1-13.	
P2-04	204	✓	rw		Fixed frequency FF4 / speed 4	50.0
					P1-10 = 0 → -P1-02 - P1-01 → Hz P1-10 > 0 → -P1-02 - P1-01 x 60 s → rpm (1/min) 0.00 Hz (P1-02) up to the maximum frequency value (P1-01). Activation via digital inputs depending on parameters P1-12 and P1-13.	
P2-05	201	✓	rw		Fixed frequency FF5 / speed 5	0.0
					P1-10 = 0 → -P1-02 - P1-01 → Hz P1-10 > 0 → -P1-02 - P1-01 x 60 s → rpm (1/min) 0.00 Hz (P1-02) up to the maximum frequency value (P1-01). Activation via digital inputs depending on parameters P1-12 and P1-13.	
P2-06	206	✓	rw		Fixed frequency FF6 / speed 6	0.0
					P1-10 = 0 → -P1-02 - P1-01 → Hz P1-10 > 0 → -P1-02 - P1-01 x 60 s → rpm (1/min) 0.00 Hz (P1-02) up to the maximum frequency value (P1-01). Activation via digital inputs depending on parameters P1-12 and P1-13.	

PNU	ID	Access right		Value	Description	DS
		RUN	ro/rw			
P2-07	207	✓	rw		Fixed frequency FF7 / speed 7	0.0
					P1-10 = 0 → -P1-02 - P1-01 → Hz P1-10 > 0 → -P1-02 - P1-01 x 60 s → rpm (1/min)	
					0.00 Hz (P1-02) up to the maximum frequency value (P1-01). Activation via digital inputs depending on parameters P1-12 and P1-13.	
P2-08	208	✓	rw		Fixed frequency FF8 / speed 8	0.0
					P1-10 = 0 → -P1-02 - P1-01 → Hz P1-10 > 0 → -P1-02 - P1-01 x 60 s → rpm (1/min)	
					0.00 Hz (P1-02) up to the maximum frequency value (P1-01). Activation via digital inputs depending on parameters P1-12 and P1-13.	
P2-09	209	✓	rw		Frequency skip 1, bandwidth (hysteresis range)	0
					0.00 - P1-01 (f _{max})	
P2-10	210	✓	rw		Frequency skip 1, center	0
					P1-02 (f _{min}) - P1-01 (f _{max})	
					The skip frequency function is used to prevent the variable frequency drive from being run at a specific output frequency, e.g. at a frequency that will cause mechanical resonance in a specific machine. Parameter P2-10 is used to define the center of the skip frequency band and is used together with parameter P2-09. The output frequency will run through the specified band at the speeds set in P1-03 or P1-04 without holding an output frequency that falls within the defined band. If the frequency reference value applied to the variable frequency drive falls within the band, the output frequency will remain at the upper or lower limit of the band.	

6 Parameters

PNU	ID	Access right		Value	Description	DS
		RUN	ro/rw			
P2-11	211	✓	rw		AO1 signal	8
					Digital output → +24 V DC	
				0	RUN, enable (FWD, REV)	
				1	READY, ready for operation	
				2	Output frequency = frequency reference value	
				3	Output frequency > zero speed	
				4	Output frequency closing threshold > P2-16 Switch off threshold < P2-17	
				5	Output current closing threshold > P2-16 Switch off threshold < P2-17	
				6	Output torque closing threshold > P2-16 Switch off threshold < P2-17	
				7	AI2 signal level closing threshold > P2-16 Switch off threshold < P2-17	
					Analog output → P2-12	
				8	Output frequency f-Out → 0 - 100 % f_{max} (P1-01)	
9	Output current → 0 - 200 % I_e (P1-08)					
10	Torque M_N → 0 - 200 % (calculated value)					
11	Output power P_N → 0 - 150 % (I_e)					
P2-12	212	✓	rw		AO1, signal range	R0 - 10
				R0 - 10	0 - 10 V	
				R10 - 0	10 - 0 V	
				R0 - 20	0 - 20 mA	
				R20 - 0	20 - 0 mA	
				R4 - 20	4 - 20 mA	
				R20 - 4	20 - 4 mA	

PNU	ID	Access right		Value	Description	DS
		RUN	ro/rw			
P2-13	213	✓	rw		A01 signal	9
					Digital output → +24 V DC	
				0	RUN, enable (FWD, REV)	
				1	READY, ready for operation	
				2	Output frequency = frequency reference value	
				3	Output frequency > zero speed	
				4	Output frequency closing threshold > P2-19 Switch off threshold < P2-20	
				5	Output current closing threshold > P2-19 Switch off threshold < P2-20	
				6	Output torque closing threshold > P2-19 Switch off threshold < P2-20	
				7	AI2 signal level closing threshold > P2-19 Switch off threshold < P2-20	
					Analog output → 0 - 10 V DC	
				8	Output frequency f-Out → 0 - 100 % f_{max} (P1-01)	
9	Output current → 0 - 200 % I_e (P1-08)					
10	Torque M_N → 0 - 200 % (calculated value)					
11	Output power P_N → 0 - 150 % (I_e)					
P2-14	214	✓	rw		A01, signal range	<i>RD-10</i>
				<i>RD-10</i>	0 - 10 V	
				<i>RD-10-0</i>	10 - 0 V	
				<i>RD-20</i>	0 - 20 mA	
				<i>RD-20-0</i>	20 - 0 mA	
				<i>RD-4-20</i>	4 - 20 mA	
				<i>RD-4</i>	20 - 4 mA	

6 Parameters

PNU	ID	Access right		Value	Description	DS
		RUN	ro/rw			
P2-15	215	✓	rw		K1 signal (Relay Output 1)	1
					Used to select the function assigned to the relay output. The relay has three output terminals (changeover contacts): Logic 1 indicates that the relay is active: This is why terminals 14 and 15 are connected to each other.	
				0	RUN, enable (FWD, REV)	
				1	READY, ready for operation	
				2	Output frequency = frequency reference value	
				3	Output frequency > 0 Hz	
				4	Output Frequency Closing threshold > P2-16 Switch off threshold < P2-17	
				5	Output current Closing threshold > P2-16 Switch off threshold < P2-17	
P2-16	216	✓	rw		AO1 / K1 upper limit	100.0
					The adjustable upper limit value that is being used in connection with settings 4 to 7 of P2-11 and P2-15	
					0.0 - 200.0 %	
P2-17	217	✓	rw		AO1 / K1 lower limit	0.0
					The adjustable lower limit value that is being used in connection with settings 4 to 7 of P2-11 and P2-15	
					0.0 - 200.0 %	

PNU	ID	Access right		Value	Description	DS										
		RUN	ro/rw													
P2-18	218	✓	rw		K2 signal (Relay Output 1)	0										
					Used to select the function assigned to the relay output. The relay has two output terminals: Logic 1 indicates that the relay is active. This is why terminals 17 and 18 are connected to each other.											
				0	RUN, enable (FWD, REV)											
				1	READY, variable frequency drive ready for operation											
				2	Output frequency = frequency reference value											
				3	Output frequency > 0 Hz											
				4	Output Frequency Closing threshold > P2-16 Switch off threshold < P2-17											
				5	Output current Closing threshold > P2-16 Switch off threshold < P2-17											
				6	Output torque (calculated value) Closing threshold > P2-16 Switch off threshold < P2-17											
P2-19	219	✓	rw		A02/K2 upper limit	100.0										
					The adjustable upper limit value that is being used in connection with settings 4 to 7 of P2-13 and P2-18											
					0.0 - 200.0 %											
				P2-20	220		✓	rw		A02/K2 lower limit	0.0					
										The adjustable lower limit value that is being used in connection with settings 4 to 7 of P2-13 and P2-18						
										0.0 - 200.0 %						
									P2-21	221		✓	rw		Scaling factor for value	0.00
															The variable selected with P2-22 is scaled with the factor selected in P2-21.	
															-30.00 - 30.00	
P2-22	222	✓	rw						scaled display value	0						
									Used to select the variable that should be scaled with the factor specified in P2-21.							
						0			Output Frequency							
				1	Output current											
				2	Analog input 2											
	3	P0-80 value														

6 Parameters

PNU	ID	Access right		Value	Description	DS
		RUN	ro/rw			
P2-23	223	✓	rw		Holding time for speed of 0	0.2
					Used to define the time that the variable frequency drive will continue to output 0 Hz (after reaching 0 Hz) before stopping. 0.0 - 60.0 s	
P2-24	224	✓	–		Clock frequency	FS2: 16 kHz FS3, FS4, FS5: 8 kHz FS6, FS7: 4 kHz
					4 - 32 kHz RMS switching frequency of power stage. A higher frequency will reduce motor noise and improve the output current's waveform, while causing increased heat loss in the variable frequency drive.	
P2-25	225	✓	rw		Quick stop deceleration ramp time/deceleration time (dec 2)	0.0
					Ramp time for quick deceleration ramp Note: In the event of a power failure, it is selected automatically or via a digital input (DI) if P2-38 = 2. If the parameter is set to 0.0, the motor will coast until it stops. 0.0 - 240.0 s	
P2-26	226	✓	rw		Flying restart circuit	0
					If this parameter is enabled, the variable frequency drive will attempt, upon starting, to determine whether the motor is already turning and to reduce its current speed in a controlled manner. A brief deceleration will occur if motors that are not already turning are started.	
					0 Deactivated 1 Enabled	
P2-27	227	✓	rw		Delay time in Standby mode	0.0
					Activates the Standby mode	
					0.0 Standby mode deactivated > 0 - 250 s The drive will switch to standby mode (the output will be deactivated) if the minimum speed (P1-02) is maintained for the time specified in this parameter. Operation will resume automatically as soon as the setpoint frequency increases to a frequency higher than P1-02.	

PNU	ID	Access right		Value	Description	DS
		RUN	ro/rw			
P2-28	228		rw		Slave speed scaling	0
					This parameter is only enabled in keypad mode (P1-12 = 1 or 2) and slave mode (P1-12 = 5). The setpoint value can be scaled with a factor (P2-29), with the factor and by additionally adding the analog input (P2-29 + AI1), or with the factor and an additional factor (P2-29 x AI1).	
				0	Deactivated	
				1	Process speed → Digital speed x P2-29	
				2	Process speed → (Digital speed x P2-29) + AI1	
P2-29	229	✓	rw		Slave speed scaling factor	100.0
					Factor for P2-28	
					-500 - 500 %	
P2-30	230		rw		AI1, Signal range	RD - 10
				RD - 10	0 to 10 V signal (unipolar) The variable frequency drive will remain at 0.0 Hz if the analog signal is < 0.0 % after scaling and applying the corresponding offset.	
				R 10 - 0	0 to 10 V signal (unipolar). The variable frequency drive will remain at 0.0 Hz if the analog signal is < 0.0 % after scaling and applying the corresponding offset.	
				- 10 - 10	-10 to 10 V signal (bipolar). The variable frequency drive will drive the motor in the reverse operating direction as soon as the analog reference value is less than 0.0 % after scaling and applying the corresponding offset.	
				RD - 20	0 to 20 mA (unipolar) The variable frequency drive will remain at 0.0 Hz if the analog signal is < 0.0 % after scaling and applying the corresponding offset.	
				t 4 - 20	4 to 20 mA signal The variable frequency drive will be switched off and show failure code 4 - 20F as soon as the signal level falls below 3 mA.	
				r 4 - 20	4 to 20 mA signal The variable frequency drive will run as per a ramp all the way to a stop as soon as the signal level falls below 3 mA.	
				t 20 - 4	20 to 4 mA signal The variable frequency drive will be switched off and show failure code 4 - 20F as soon as the signal level falls below 3 mA.	
				r 20 - 4	20 to 4 mA signal The variable frequency drive will run as per a ramp all the way to a stop as soon as the signal level falls below 3 mA.	

6 Parameters

PNU	ID	Access right		Value	Description	DS
		RUN	ro/rw			
P2-31	231	✓	rw		AI1 scaling factor	100.0
					0 - 500 % Scales the analog input by this factor; e.g., if P2-30 is configured for a 0 - 10 V signal and the scaling factor is set to 200.0 %, 5 V at the input will cause the variable frequency drive to run at the maximum frequency / speed (P-01).	
P2-32	232	✓	rw		Analog input 1 Offset	0.0
					-500.0 - +500.0 % Used to set an offset as a percentage of the input's full scale range so that this offset will be applied to the analog input signal.	
P2-33	233	✓	rw		AI2, Signal range	UI - IO
				UI - IO	0-10 V signal (unipolar). The variable frequency drive will remain at 0.0 Hz if the analog signal is < 0.0 % after scaling and applying the corresponding offset.	
				UIO - 0	10-0 V signal (unipolar). The variable frequency drive will remain at 0.0 Hz if the analog signal is < 0.0 % after scaling and applying the corresponding offset.	
				Ptc - th	Motor thermistor input	
				AO - 20	0 to 20 mA (unipolar) The variable frequency drive will remain at 0.0 Hz if the analog signal is < 0.0 % after scaling and applying the corresponding offset.	
				t4 - 20	4-20 mA signal The variable frequency drive will be switched off and show failure code 4 - 20F as soon as the signal level falls below 3 mA.	
				r4 - 20	4-20 mA signal The variable frequency drive will run as per a ramp all the way to a stop as soon as the signal level falls below 3 mA.	
				t20 - 4	20-4 mA signal The variable frequency drive will be switched off and show failure code 4 - 20F as soon as the signal level falls below 3 mA.	
P2-34	234	✓	rw		AI2 scaling factor	100.0
					0 - 500 % Used to scale the analog input by this factor. For example, if P2-33 is configured for a 0 - 10 V signal and the scaling factor is set to 200.0 %, 5 V at the input will cause the variable frequency drive to run at the maximum frequency / speed (P-01).	

PNU	ID	Access right		Value	Description	DS
		RUN	ro/rw			
P2-35	235	✓	rw		AI2 offset	0.0
					-500.0 - +500.0 % Used to set an offset as a percentage of the input's full scale range so that this offset will be applied to the analog input signal.	
P2-36	236	✓	rw		REAF, Start function with automatic restart	<i>E d 9 E - r</i>
					Used to define the variable frequency drive's behavior concerning the enable digital input and to configure the automatic restart function.	
				<i>E d 9 E - r</i>	disabled (the variable frequency drive will need a new start edge) : After being switched on, as well as after a reset, the variable frequency drive will not start if digital input 1 remains closed. The input must be closed after switching on, as well as after a reset, in order to start the variable frequency drive.	
				<i>R U E a - 0</i>	The variable frequency drive will start automatically (The variable frequency drive does not need a start edge; the signal will continue to be applied). After being switched on, as well as after a reset, the variable frequency drive will start automatically if digital input 1 is closed.	
				<i>R U E a - 1</i>	The variable frequency drive will start automatically once. After a trip, the variable frequency drive will make up to five attempts to restart at 20-second intervals. The variable frequency drive must be de-energized in order to reset the counter. The number of restart attempts is counted. If the variable frequency drive does not start after the last attempt, it will switch to an error condition and request the user to reset the error manually.	
				<i>R U E a - 2</i>	The variable frequency drive will start automatically twice.	
				<i>R U E a - 3</i>	The variable frequency drive will start automatically three times.	
				<i>R U E a - 4</i>	The variable frequency drive will start automatically four times.	
				<i>R U E a - 5</i>	The variable frequency drive will start automatically five times.	

6 Parameters

PNU	ID	Access right		Value	Description	DS
		RUN	ro/rw			
P2-37	237	✓	rw		REAF, Start function with automatic restart, operating unit	1
					This parameter will only be active if the keypad control operating mode is being used (P-12 = 1 or 2).	
				0	Minimum speed; keypad The keypad's start and stop pushbuttons are enabled, and control signal terminals 1 and 2 must be connected. The variable frequency drive will always start with the minimum frequency/speed (P1-02).	
				1	Previous speed, keypad The keypad's start and stop pushbuttons are enabled; control signal terminals 1 and 2 must be connected. The variable frequency drive will always start with the most recent operating frequency/speed.	
				2	Current speed The variable frequency drive will start with the most recent current speed without a new start signal.	
				3	Fixed frequency 8 After a stop, the variable frequency drive will start with fixed frequency 8 (P2-08) without a new start command.	
				4	Minimum frequency (P1-02) After a stop, the variable frequency drive will start with the minimum frequency (P1-02) without a new start signal (terminal enable).	
				5	Most recently set speed After a stop, the variable frequency drive will start with the most recent current frequency (keypad setpoint value) without a new start signal (terminal enable).	
				6	Current speed If the variable frequency drive is configured for multiple speed reference values (typically manual/auto control or local/remote control) and a digital input is setting it to setpoint value = keypad, the motor will continue to be run with the most recent setpoint value (terminal enable)	
				7	Fixed frequency 8 After a stop, the variable frequency drive will start with fixed frequency 8 (P2-08) without a new start command (terminal enable).	

PNU	ID	Access right		Value	Description	DS
		RUN	ro/rw			
P2-38	238	✓	rw		Response in the event of a power failure	0
					Used to control the variable frequency drive's behavior after a power supply loss while the drive is switched on.	
				0	Voltage support in the event of a power failure The variable frequency drive will reduce the output frequency as specified in the ramp (dec1). The regenerative energy recovered from the motor's load will continue to power the variable frequency drive, provided the power failure is brief and enough energy can be recovered from the machine in order to power the controller.	
				1	Stop, free coasting The variable frequency drive will immediately deactivate the output so that the motor will coast. If this setting is used for loads with a large moment of inertia, the flying restart circuit (P2-26) should be enabled in order to make it possible to restart quickly.	
				2	Quick stop (P2-25) The variable frequency drive will stop with the quick stop ramp time (dec2) set in parameter P2-25.	
	3	Only DC power supply present This mode should be used if the variable frequency drive is being powered directly with the +DC- and -DC bus connections. Undervoltage detection is disabled in this mode.				
P2-39	239	✓	rw		Parameter access lock	0
				0	Deactivated Access to all parameters Changes are allowed (some of them are not allowed in RUN mode, however).	
				1	Activated Parameter values can be shown, but cannot be edited.	
P2-40	240	✓	rw		Access codes - menu level 2	101
				0 - 9999 Used to define the access code that must be entered into P1-14 to allow access to parameter groups 1 to 5.		

6 Parameters

PNU	ID	Access right		Value	Description	DS
		RUN	ro/rw			
Parameter group P3 – PID controller						
P3-01	301	✓	rw		PID controller proportional gain	1.0
					0.1 - 30.0 % Higher values will result in a larger change to the variable frequency drive output frequency as a response to small changes in the feedback signal. An excessively high value can cause instability.	
P3-02	302	✓	rw		PID controller, integral time constant	1.0
					0.00 - 30.0 s Higher values will result in a more damped response for systems in which the overall process responds slowly.	
P3-03	303	✓	rw		PID controller, D rate time	0.00
					0.00 - 1.00 s PID controller, Differential Time Constant	
P3-04	304	✓	rw		PID controller, control deviation	0
				0	direct operation Note: This mode should be used if a decrease in the feedback signal's level should result in a higher motor speed.	
				1	Inverse operation Note: This mode should be used if an increase in the feedback signal's level should result in a higher motor speed.	
P3-05	305	✓	rw		PID controller, setpoint source	0
				0	Preset digital setpoint value (P3-6)	
				1	AI1	
				2	AI2	
P3-06	306	✓	rw		PID controller, digital reference value	0.0
					0.00 - 100 % Is used at P3-05 = 0	
P3-07	307	✓	rw		PID controller, actual value limiting, maximum	100.0
					0.0 - 100.0 % Is used at P3-09 = 0	
P3-08	308	✓	rw		PID controller, actual value limiting, minimum	0.0
					0.0 - 100.0 % Is used at P3-09 = 0	

PNU	ID	Access right		Value	Description	DS
		RUN	ro/rw			
P3-09	309	✓	rw		PID controller, actual value limiting Selections	0
				0	Actual value limiting (P3-08 - P3-07)	
				1	AI1 = Actual value limiting, maximum	
				2	AI1 = Actual value limiting, minimum	
				3	PID controller output + AI1	
P3-10	310	✓	rw		PID controller, actual value (PV) feedback signal	0
				0	0 = AI1	
				1	1 = AI2	
P3-11	311	✓	rw		Maximum PID error for enabling the ramps	0.0
					0.00 - 25.0 % Used to define a PID error threshold value. If the PID error (the difference between the setpoint and the process variable) is smaller than the threshold value, the variable frequency drive's internal ramps will be deactivated.	
P3-12	312	✓	rw		PID feedback display scaling factor	0.00
					0 - 50 % Applies a scaling factor to the displayed PID feedback, allowing the user to display the actual signal level from a transducer.	
P3-13	313	✓	rw		PID feedback wake up level	0.0
					0.0 - 100.0 % Sets an error level (difference between the PID reference and feedback values) above which the PID controller will wake from Standby mode.	
P3-14	–	–	–	–	reserved	–
P3-15	–	–	–	–	reserved	–
P3-16	–	–	–	–	reserved	–
P3-17	–	–	–	–	reserved	–
P3-18	318	✓	rw		PID reset control	0
					This parameter controls the PID loop's resetting behavior.	
				0	The PID loop will run continuously as long as the proportional gain (P3-01) is not 0.	
				1	The PID loop will only run if the drive is active. If the drive is not running, the PID output will be reset to 0 (incl. integer result).	

6 Parameters

PNU	ID	Access right		Value	Description	DS
		RUN	ro/rw			
Parameter group P4 – Motor Control mode select						
P4-01	401	–	rw		Motor control mode selection	2
					Used to select the motor control method. If setting 0, 1, 3, or 4 is used, the auto-tune function must be used (P4-02 = 1).	
				0	Speed control with torque limit (vector)	
				1	Torque control with speed limit (vector)	
				2	Frequency control (V/f)	
				3	PM motor speed control	
				4	PM motor torque regulation	
				5	BLDC motor speed control	
P4-02	402	–	ro		Auto-tune motor parameter	0
					When set to 1, the drive immediately carries out a non-rotating autosetting to measure the motor parameters for optimum control and efficiency. Following completion of the autosetting, the parameter automatically returns to 0.	
					Note: This function cannot be enabled using the computer software!	
	0	Deactivated				
	1	Auto-tune (only with the motor stopped / resets to 0)				
P4-03	403	✓	rw		Rotational speed controller P gain	50.0
					Sets the proportional gain value for the speed controller when operating in Vector Speed motor control mode (P4-01 = 0).	
					0.1 - 400 %	
P4-04	404	✓	rw		Rotational speed controller integral time	0.050
					Sets the integral time for the speed controller in Vector Speed control mode (P4-01 = 0).	
					0.001 - 1.00 s	
P4-05	405	✓	rw		Motor power factor (cos φ)	0.78
					Note: When operating in Vector Speed or Vector Torque motor control modes, this parameter must be set to the motor nameplate power factor before autosetting (autotune).	
					0.5 - 0.99	

PNU	ID	Access right		Value	Description	DS
		RUN	ro/rw			
P4-06	406	✓	rw		Torque setpoint/limit If P4-01 = 0, this parameter defines the source for the output torque's maximum value. If P4-01 = 1, this parameter defines the source for the torque frequency (setting point)	0
				0	Fixed digital torque limit The limit value is set in P04-07.	
				1	Analog input 1 (AI1) will control the torque from 0 to P04-07.	
				2	Analog input 2 (AI2) will control the torque from 0 to P4-07.	
				3	Field bus. The field bus torque setpoint is used, limited by P4-07.	
				4	Master/Slave. The master's torque reference value will be used as the torque limit for the slave.	
	5	PID controller output. The PID controller will be used to control the torque from 0 to P4-07.				
P4-07	407	✓	rw		Maximum torque (motor) When operating in Vector Speed or Vector Torque motor control modes (P4-01 = 2), this parameter defines the maximum torque limit or reference used by the drive in conjunction with P4-06 parameters. P4-08 - 500 %	200
					Minimum torque Active only in Vector Speed or Vector Torque motor control modes (P4-01 = 2). Used to define a minimum torque so that, if the drive is active, the system will always attempt to ensure this torque on the motor. Note: This parameter should be used with care, as the drive output frequency will increase to achieve the set torque level, and may exceed the setpoint frequency. 0.00 - P4-07 %	
P4-08	408	✓	rw		Maximum torque (generator) Active only in Vector Speed or Vector Torque motor control modes (P4-01 = 2). Sets the maximum regenerating torque allowed by the drive. 0.00 - 200 %	200
					V/Hz characteristic curve modification voltage When operating in V/f mode (P4-01 = 2), this parameter in conjunction with P4-11 sets a frequency point at which the voltage set in P4-11 is applied to the motor. Note: Care must be taken to avoid overheating and damaging the motor when using this function. 0.00 - P1-09 %	
P4-09	409	✓	rw			0.0
P4-10	410	–	rw			0.0

6 Parameters

PNU	ID	Access right		Value	Description	DS	
		RUN	ro/rw				
P4-11	411	✓	rw		V/Hz characteristic curve modification frequency	0.0	
					Used in conjunction with P4-10.		
					0.00 - P1-07 %		
P4-12	412	–	–	–	reserved		
Parameter group P5 – Field bus							
P5-01	501	✓	rw		Variable frequency drive slave address	1	
					Used to set the drive network address when using the field bus or master/slave function. Even if multiple variable frequency drives are connected with drivesConnect.		
					0 - 63		
P5-02	502	✓	rw		CANopen baudrate	2	
					Sets the baud rate when CANopen communications are used.		
					0		125 kbit/s
					1		250 kbit/s
					2		500 kbit/s
P5-03	503	✓	rw		Modbus RTU Baud rate	4	
					Sets the baud rate when Modbus communications are used.		
					0		9.6 kbit/s
					1		19.2 kbit/s
					2		38.4 kbit/s
P5-04	504	✓	rw		Modbus RTU data format – Parity type	n - 1	
					n - 1		No parity, 1 stop bit
					n - 2		No parity, 2 stop bits
					0 - 1		Odd parity, 1 stop bit
					E - 1		Even parity, 1 stop bit
P5-05	505	✓	rw		Timeout – Communications dropout	1	
					Sets the watchdog time period for the communications channel.		
					With an active communication link, if a valid telegram is not received by the drive within this time period, the drive will assume a loss of communications has occurred and react as set in P5-06.		
					0.00 - 5.00 s		

PNU	ID	Access right		Value	Description	DS
		RUN	ro/rw			
P5-06	506	✓	rw		Response in the event of a communications dropout	0
					Used to control the drive's behavior in the event of a loss of communications.	
					0 = Switch off and free coasting	
					1 = Deceleration ramp, switch off	
					2 = Deceleration ramp, no switch off	
				3 = Fixed frequency 8		
P5-07	507	✓	rw		Ramp via field bus	0
					Used to define whether the acceleration and deceleration ramps will be controlled directly through the field bus or through internal drive parameters.	
				0	Deactivated Ramps will be controlled using internal drive parameters.	
				1	Activated Ramps will be controlled directly through the field bus.	
P5-08	508	✓	rw		Field bus module PDO-4 output	0
					When using an optional field bus interface, this parameter configures the parameter source for the 4th process data word transferred from the network master to the drive during cyclic communications.	
				0	Output torque, as a percentage, with one decimal place (Example: 123 = 12.3 %)	
				1	Output power, in kW, with two decimal places (Example: 400 = 4.00 kW)	
				2	Digital input (DI) states → Bit 0 gives the state of digital input 1 (DI1), bit 1 the state of digital input 2 (DI2), etc.	
				3	Signal level analog input 2 (AI2) → 0 - 1000 = 0 - 100.0 %	
				4	Heat sink temperature → 0 - 100 = 0 - 100 °C	
				5	User register 1 → Can be accessed with the PLC program (internally) or parameter group 9.	
6	User register 2 → Can be accessed with the PLC program (internally) or parameter group 9.					
				7	Value P0-80 can be selected via P6-28.	
P5-09	-	-	-	-	reserved	
P5-10	-	-	-	-	reserved	
P5-11	-	-	-	-	reserved	

6 Parameters

PNU	ID	Access right		Value	Description	DS
		RUN	ro/rw			
P5-12	512	✓	rw		Field bus module PDO-3 output	0
					When using an optional field bus interface, this parameter configures the parameter source for the 3rd process data word transferred from the network master to the drive during cyclic communications.	
				0	Motor current, as a percentage, with one decimal place (Example: 123 = 12.3 %)	
				1	Output power, in kW, with two decimal places (Example: 400 = 4.00 kW)	
				2	Digital input (DI) states → Bit 0 gives the state of digital input 1 (DI1), bit 1 the state of digital input 2 (DI2), etc.	
				3	Signal level analog input 2 (AI2) → 0 - 1000 = 0 - 100.0 %	
				4	Heat sink temperature → 0 - 100 = 0 - 100 °C	
				7	User register 1 → Can be accessed with the PLC program (internally) or parameter group 9.	
P5-13	513	✓	rw		Field bus module PDI-4 input	0
					When using an optional Fieldbus interface, this parameter configures the parameter source for the 4th process data word transferred from the network master to the drive during cyclic communications.	
				0	Field bus ramp control, defined in seconds with two decimal places	
				1	User register 4 → Can be accessed with the PLC program (internally) or parameter group 9.	
P5-14	514	✓	rw		Field bus module PDI-3 input	0
					When using an optional field bus interface, this parameter configures the parameter source for the 3rd process data word transferred from the network master to the drive during cyclic communications.	
				0	Torque limit / reference → -5000 to 5000 = -500.0 to 500.0 %	
				1	User PID reference → 0 to 1000 = 0 to 100.0 %	
				2	User register 3 → Can be accessed with the PLC program (internally) or parameter group 9.	

PNU	ID	Access right		Value	Description	DS
		RUN	ro/rw			
Extended parameter range Level 3 (access: P1-14 = 201)						
Parameter group P6 – extended						
P6-01	601	–	rw		Firmware update enable	0
					Enables firmware update mode so that the firmware for the user interface and/or the power control system can be updated	
				0	Deactivated	
				1	User interface and power section update	
				2	User interface update	
P6-02	602	✓	rw		Auto temperature management	0
					When enabled, the drive will automatically reduce the output frequency at higher heatsink temperature, to reduce the risk of an over temperature trip.	
				0	4 kHz	
				1	8 kHz	
				2	12 kHz	
P6-03	603	✓	rw		Auto-reset delay	20
					Sets the delay time which will elapse between consecutive drive reset attempts when Auto Reset is enabled in P2-36. 1 - 60 s	
P6-04	604	✓	rw		Relay hysteresis band	3
					This parameter is used together with P2-11 and P2-13 = 2 or 3 in order to define a range for the speed setpoint (P2-11 = 2) or the zero speed (P2-11 = 3). If the speed falls within this range, the drive is at the speed setpoint or zero speed. This function prevents contact chatter at the relay output if the operating speed matches the level at which the digital/relay output changes state. For example, relay contacts will close over 2.5 Hz if P2-13 = 3, P1-01 = 50 Hz, and P6-04 = 5 %. 0.00 - 25.0 %	
P6-05	605	–	rw		Enable incremental encoder feedback	0
					Setting this parameter to 1 enables the encoder operating mode. In order to ensure that the unit will work correctly, make sure that the encoder is correctly placed on the motor and that the wiring is connected to the encoder feedback module as specified in the manual. Before enabling this parameter, use parameter P0-57 (encoder feedback speed) to ensure that the direction of rotation in the V/Hz mode is correct. The sign in P0-57 must match the sign for the speed reference.	
				0	Deactivated	
				1	Activated	

6 Parameters

PNU	ID	Access right		Value	Description	DS
		RUN	ro/rw			
P6-06	606	–	rw		<p>Incremental encoder scale</p> <p>Used to define the number of pulses per revolution for the encoder. This value must be configured correctly in order to ensure that the drive will work properly when the encoder feedback mode is enabled (P6-05 = 1). If this parameter is configured incorrectly, a drive control loss and/or a trip may occur. If this parameter is set to 0, encoder feedback will be disabled.</p> <p>0 - 65535</p>	0
P6-07	607	✓	rw		<p>Maximum speed error</p> <p>This parameter defines the maximum permissible speed error between the encoder feedback speed value and the estimated rotor speed calculated by the motor control algorithms. If the speed error exceeds this limit value, the drive will trip. When set to zero, this protection is disabled.</p> <p>0.00 - 50.0 %</p>	5
P6-08	608	✓	rw		<p>Input frequency at maximum speed</p> <p>When the motor speed frequency is to be controlled by a frequency input signal (connected to Digital input 3, DI3), this parameter is used to define the input frequency which corresponds to the maximum motor speed (set in P1-01). This maximum frequency that can be set in this parameter must be in the range 5 kHz to 20 kHz. When set to 0, this function is disabled.</p> <p>0.5 - 20 kHz</p>	0
P6-09	609	✓	rw		<p>Droop speed</p> <p>This parameter will only be applied if the drive is being run in vector speed control mode (P4-01 = 0). When set to 0, the "Droop speed" control function is disabled.</p> <p>If P6-09 > 0, this parameter actually defines a slip speed for the rated output torque. The droop speed is the percentage in P1-09. Depending on the motor load, the reference speed at the input will be decreased in the speed controller by a specific droop speed value:</p> <p>Droop speed = P6-09 x P1-09 Droop value = Droop speed x (actual output torque / rated torque) Speed controller input = Speed reference value - droop value</p> <p>0.00 - 25.0 %</p>	0.0
P6-10	610	✓	rw		<p>PLC function enable</p> <p>This parameter enables the PLC function support and must be set to 1 before any PLC program loaded into the drive will operate. When set to 0, the PLC program will be disabled.</p> <p>0 Deactivated</p> <p>1 Activated</p>	0
P6-11	611	✓	rw		<p>Speed holding time in the event of an enable signal</p> <p>Defines a time period for which the drive will run at Preset Speed 7 (P2-07) when the Enable signal is applied to the drive. This feature can be used on pumps to provide a reverse spin on start up, to clear potential blockages.</p> <p>0.00 - 250 s</p>	0

PNU	ID	Access right		Value	Description	DS
		RUN	ro/rw			
P6-12	612	✓	rw		Speed holding time in the event of a disable signal	0
					Defines a time period for which the drive will run at Preset Speed 8 (P2-08) following removal of the Enable signal, before deceleration Ramp to activate. This feature can be used in applications such as underground PCP pumps to provide an unwind of the driveshaft on stopping.	
					0.00 - 250 s	
P6-13	613	✓	rw		Motor brake opening time	0.2
					Sets the time for which the drive will hold at the Brake Release Speed (set in P2-07 - Preset Speed 7) to allow the motor brake to release.	
					0.00 - 5.00 s	
P6-14	614	✓	rw		Motor brake engagement delay	0.3
					Sets the time for which the drive will hold at the Brake Apply Speed (set in P2-08 - Preset Speed 8) to allow the motor brake to engage. For vertical hoist applications this value should not be set below the time required for the brake to engage (brake response time, as specified by the brake manufacturer). The minimum time is 0.1 s.	
					0.00 - 5.00 s	
P6-15	615	✓	rw		Minimum torque for brake opening	8.0
					Used to define the torque level (as a percentage of the rated motor torque) that must be reached before the signal for releasing the motor brake is issued. This ensures that the motor is connected and that sufficient torque is being generated in order to prevent the load from dropping when the mechanical brake is released. The function for the torque limit is not enabled in V/Hz mode.	
					0.00 - 200 %	
P6-16	616	✓	rw		Minimum torque time limit	5.0
					Used to define the time for which the motor will attempt, after a start command, to generate sufficient torque for reaching the lifting torque level (P6-15). If the level is not reached within the set time, the drive trips.	
					0.00 - 25.0 s	
P6-17	617	✓	rw		Maximum torque time limit	0.0
					Sets the maximum time allowed for the motor to be operating at the motor/generator torque limit (P4-07 / P4-09) before tripping. This parameter is enabled only for vector control operation.	
					0.00 - 25.0 s	
P6-18	618	-	rw		Voltage for DC current braking	0
					Sets the amount of dc voltage as a percentage of the nominal voltage (P1-07) that is applied to the motor when a stop command is received. This parameter is enabled only for V/f control.	
					automatic, 0.00 - 25.0 %	

6 Parameters

PNU	ID	Access right		Value	Description	DS
		RUN	ro/rw			
P6-19	619	✓	rw		Brake resistor value	100
					Used to specify the braking resistance in ohms. This value is used for the brake resistor thermal protection. 0.25 - 200 Ω	
P6-20	620	✓	rw		Brake resistor power	0.20
					Sets the brake resistor power in kW, with a resolution of 0.1 kW. This value is used for the brake resistor thermal protection. 0.00 - 200 kW	
P6-21	621	✓	rw		Braking chopper cycle in the event of excessively low temperature	2.0
					Used to define the braking chopper's duty cycle if the drive trips due to excessively low temperature. A braking resistance can be mounted on the drive's heat sink in order to heat up the drive until the correct operating temperature is reached. Notice: It is important to exercise extreme caution when using this parameter, as the resistor's rating will be exceeded under certain circumstances if the value is set incorrectly. Thermal protection must always be used for the resistor in order to prevent this from happening. 0.00 - 20.0 %	
P6-22	622	✓	rw		Reset fan run-time	0
					Setting to 1 resets internal Fan run-time counter to zero (as displayed in P0-35). 0 = Deactivated 1 = Reset	
P6-23	623	✓	rw		Reset kWh meter	0
					Setting to 1 resets internal kWh meter to zero (as displayed in P0-26 and P0-27). 0 = Deactivated 1 = Reset	
P6-24	624	✓	rw		Service interval	0
					Used to define the service interval. It specifies the total operating time, in hours, required for the maintenance indicator to be activated on the OLED display. If P2-25 = 1, the internal maintenance counter will be set to this value. 0 - 60000 h	
P6-25	625	✓	rw		Reset service interval	0
					When this parameter is set to 1, the internal service interval counter is set to the value defined in P6-24. 0 = Deactivated 1 = Reset	

PNU	ID	Access right		Value	Description	DS
		RUN	ro/rw			
P6-26	626	✓	rw		A01 - scaling	100
					Defines the scaling factor as a percentage used for analog input 1 (AI1). 0.00 - 500 %	
P6-27	627	✓	rw		A01 offset	0.0
					Defines the offset as a percentage used for analog output 1 (AO1). -500 - 500 %	
P6-28	628	✓	rw		Display index P0-80	0
					This parameter is used to define the index for the internal variable. The value is shown in P0-80. This parameter is normally used in conjunction with the PLC function. 0 - 127	
P6-29	629	—	rw		Save parameters as default	0
					Setting this parameter to 1 saves the current parameter settings as "User default parameters". When the User carries out a 3-button command for default parameters (UP, DOWN and STOP), the parameter saved when P6-29 was last set to 1 will be restored.	
					0 Deactivated	
					1 Activated	
P6-30	630	✓	rw		Access code for menu level 3	201
					Defines the access code which must be entered into P1-14 to allow access to the Advanced Parameters in Groups 6 to 9. 0 - 9999	

6 Parameters

PNU	ID	Access right		Value	Description	DS
		RUN	ro/rw			
Parameter group P7 – Motor						
P7-01	701	✓	rw		Motor stator resistance	4.00
					For induction and PM motors: Phase to phase rotor resistance value in ohms (Ω).	
					0.00 - 65.535 Ω	
P7-02	702	✓	rw		Rotor resistance	3.00
					For induction motors Phase to phase rotor resistance value in ohms (Ω).	
					0.00 - 65.535 Ω	
P7-03	703	✓	rw		Motor leakage inductance (d)	0.15
					For induction motors: phase stator inductance value	
					For permanent magnet motors: Phase d-axis stator inductance in Henry (H)	
					0,0000 - 6.5535 H	
P7-04	704	✓	rw		Motor magnetizing current	
					For induction motors: Magnetizing/no-load current. Before auto-setting, an estimated value of 30 to 40 % of the rated motor current (P1-08) and a motor power factor of 0.8 will be used.	
					0.0 - 3.4 A	
P7-05	705	✓	rw		Motor leakage factor	0.10
					For induction motors: motor leakage inductance coefficient.	
					0.00 - 0.25	
P7-06	706	✓	rw		Motor leakage inductance (q)	0.15
					For permanent magnet motors: Phase d-axis stator inductance in Henry (H)	
					0,0000 - 6.5535 H	
P7-07	707	✓	rw		Advanced generator control	0
					For induction and PM motors: This parameter performs small changes in the motor model to allow low speed generator mode operation.	
				0	Deactivated	
				1	Activated	
P7-08	708	✓	rw		Enable, motor parameter adaptation	0
					For induction and PM motors: This parameter is only effective in vector operation and allows the stator and rotor resistance to be adapted during normal operation.	
				0	Deactivated	
				1	Activated	

PNU	ID	Access right		Value	Description	DS
		RUN	ro/rw			
P7-09	709	✓	rw		<p>Overvoltage current limit</p> <p>This parameter is only applied in vector speed control mode and is enabled as soon as the drive's DC link voltage exceeds a specific value. This voltage value is internally set just under the value for a voltage-induced trip. The parameter limits the output torque current in order to prevent a large current from flowing back into the drive and possibly triggering an overvoltage trip. A lower value for this parameter will limit the motor torque control if the drive's DC link voltage exceeds the set limit value. A higher value can result in heavy motor current distortion, which can lead to aggressive, rough motor behavior.</p> <p>0.00 - 100 %</p>	1
P7-10	710	✓	rw		<p>Load inertia factor</p> <p>The ratio between the system load inertia and the motor inertia is specified as $H = (J_{Tot}/J_{Mot})$. This value can usually be left at its default value of 10 and is used by the drive control algorithm as a variable for the feed forward control (FWD) in order to deliver the ideal torque current for accelerating the load. Accordingly, setting the inertia ratio in an accurate manner will improve the system's response and dynamics.</p> <p>0 - 600</p>	10
P7-11	711	✓	rw		<p>Minimum PWM pulse width</p> <p>This parameter is used to limit the minimum width of the output pulse in applications with long cables. Increasing the value of this parameter will reduce the risk of an overcurrent trip when using long motor cables, but, at a certain input voltage, will also reduce the maximum available motor voltage.</p> <p>0 - 500</p>	150
P7-12	712	✓	rw		<p>Magnetizing time at the V/f method</p> <p>This parameter is used to set up a minimum delay time for the magnetizing current control in V/F mode when drive run signal is given. Too small a value may cause the drive to trip on overcurrent if the acceleration ramp is very short.</p> <p>0 - 2000 ms</p>	30
P7-13	713	✓	rw		<p>Speed controller differential gain</p> <p>Sets the differential gain (%) for the speed controller in vector mode operation.</p> <p>0.00 - 400 %</p>	0
P7-14	714	✓	rw		<p>Torque boost</p> <p>Voltage boost, when starting, as a percentage of the rated motor current (P1-08). The drive features a voltage boost function that can power the motor at low speeds in order to ensure proper rotor alignment and efficient motor operation at low speeds. In order to implement the voltage boost at low speeds, run the drive at the lowest speed required for the application and increase the boost level in order to reach both the required torque and achieve smooth operation.</p> <p>0.00 - 100 %</p>	0

6 Parameters

PNU	ID	Access right		Value	Description	DS
		RUN	ro/rw			
P7-15	715	✓	rw		Maximum frequency limit for torque boost	0
					Frequency range for applied boost current (P7-14) as a %age of motor rated frequency (P1-09). This sets the frequency cut-off point above which boost current is no longer applied to the motor. 0.00 - 50.0 %	
P7-16	716	✓	rw		Enable, signal injection	0
					This parameter enables the signal injection algorithm for permanent-magnet motors.	
				0	Deactivated	
				1	Signal injection during magnetizing current period	
				2	Signal injection at low speeds	
	3	Signal injection during magnetizing current period and at low speeds				
P7-17	717	✓			Signal injection level	10
					This parameter sets the level and duration of the the voltage applied to the PM motor during the magnetizing period in order to determine the position of the motor magnetic poles. Setting this value too low can cause the initial rotor position identification to fail, whereas high values could cause over-current trips. 0 - 100	

PNU	ID	Access right		Value	Description	DS
		RUN	ro/rw			
Parameter group P8 – Ramps						
P8-01	801	✓	rw		Second acceleration time (acc2)	5.0
					Used to define the ramp time for acceleration ramp 2 (acc2). The time set in this parameter is defined as the time required for the ramp to go from = to the frequency set in P1-09.	
					0.00 - 600 s	
P8-02	802	✓	rw		Transition frequency (acc1 → acc2)	0.0
					Defines the speed boundary (frequency limit) at which the acceleration ramp changes from ramp 1 to ramp 2.	
					0.00 - P1-02	
P8-03	803	✓	rw		Third acceleration time (acc3)	5.0
					like P8-01	
					0.00 - 600 s	
P8-04	804	✓	rw		Transition frequency (acc2 → acc3)	0.0
					Defines the speed boundary (frequency limit) at which the acceleration ramp changes from ramp 2 to ramp 3.	
					0.00 - P1-02	
P8-05	805	✓	rw		Fourth acceleration time (acc4)	5.0
					like P8-01	
					0.00 - 600 s	
P8-06	806	✓	rw		Transition frequency (acc3 → acc4)	0.0
					Defines the speed boundary (frequency limit) at which the acceleration ramp changes from ramp 3 to ramp 4.	
					0.00 - P1-02	
P8-07	807	✓	rw		Fourth deceleration time (dec4)	5.0
					Used to define the ramp time for deceleration ramp 4 (dec4). The time set in this parameter is defined as the time required for the ramp to go from the frequency set in P1-09 to 0.	
					0.00 - 600 s	
P8-08	808	✓	rw		Transition frequency (dec4 → dec3)	0.0
					Defines the speed boundary (frequency limit) at which the deceleration ramp changes from ramp 4 to ramp 3.	
					0.00 - P1-03	
P8-09	809	✓	rw		Third deceleration time (dec3)	5.0
					Like P8-07	
					0.00 - 600 s	
P8-10	810	✓	rw		Transition frequency (dec3 → dec2)	0.0
					Defines the speed boundary (frequency limit) at which the deceleration ramp changes from ramp 3 to ramp 2.	
					0.00 - P1-04	

6 Parameters

PNU	ID	Access right		Value	Description	DS
		RUN	ro/rw			
P8-11	811	✓	rw		Second deceleration time (dec2) Like P8-07 0.00 - 600 s	5.0
P8-12	812	✓	rw		Transition frequency (dec2 → dec1) Defines the speed boundary (frequency limit) at which the deceleration ramp changes from ramp 2 to ramp 1. 0.00 - P1-05	0.0
P8-13	813	✓	rw		Ramp selection when there is a preset speed When set to 0, Acceleration and deceleration ramps 1 are selected by default but can be reconfigured using Group 9 parameters. When set to 1, the acceleration and deceleration ramps are selected according to the parameters set in P8-01 to P8-12.	0
				0	Deactivated	
				1	Activated	
Parameter group P9 – Control						
P9-01	901	–	rw		Control source - enable Defines the source of the signal to be used for the activation input	1
				0	safe input	
				1	Digital input 1 (DI1)	
				2	Digital input 2 (DI2)	
				3	Digital input 3 (DI3)	
				4	Digital input 4 (DI4)	
				5	Digital input 5 (DI5)	
				6	Digital input 6 (DI6)	
				7	Digital input 7 (DI7)	
				8	Digital input 8 (DI8)	

PNU	ID	Access right		Value	Description	DS
		RUN	ro/rw			
P9-02	902	–	rw		Control source - quick stop	0
					Defines the source of the signal to be used for the quick stop input	
				0	OFF / deactivated	
				1	Digital input 1 (DI1)	
				2	Digital input 2 (DI2)	
				3	Digital input 3 (DI3)	
				4	Digital input 4 (DI4)	
				5	Digital input 5 (DI5)	
				6	Digital input 6 (DI6)	
				7	Digital input 7 (DI7)	
				8	Digital input 8 (DI8)	
				9	Analog output 1 (AO1)	
				10	Analog output 2 (AO2)	
				11	Digital output 1 (DO1)	
				12	Digital output 2 (DO2)	
				13	Digital output 3 (DO3)	
				14	Digital output 4 (DO4)	
				15	Digital output 5 (DO5)	
				16	ON / active	
				17	User register 1	
				18	User Register 2	
				19	User register 3	
				20	User register 4	
				21	User register 5	
				22	User register 6	
				23	User Register 7	
24	User register 8					
25	User register 9					
P9-03	903	–	rw		Control source - start signal 1 (FWD)	1
					Defines the source of the signal to be used for the start signal 1 (FWD) input.	
					like P9-02	
P9-04	904	–	rw		Control source – start signal 2 (REV)	0
					Defines the source of the signal to be used for the start signal 2 (REV) input.	
					like P9-02	

6 Parameters

PNU	ID	Access right		Value	Description	DS
		RUN	ro/rw			
P9-05	905	–	rw		Control source - stay-put function (for P9-03 and P9-04) 0 = OFF / deactivated 1 = ON / active	0
P9-06	906	–	rw		Control source - enable (REV) Defines the source of the signal to be used for the enable (REV) input like P9-02	2
P9-07	907	–	rw		Control source - reset Defines the source of the signal to be used for the reset input like P9-02	1
P9-08	908	–	rw		Control source – external fault Defines the source of the signal to be used for the external fault input like P9-02	0
P9-09	909	–	rw		Control source terminal mode Defines the source of the signal used for the terminal mode input. like P9-02	16
P9-10	910	–	rw		Source - speed 1	0
				0	Analog input 1 (AI1)	
				1	Analog input 2 (AI2)	
				2	Fixed frequency 0	
				3	Operating unit	
				4	PID controller output	
				5	Master speed	
				6	Field bus	
				7	From internal PLC program	
				8	Frequency input speed reference value	
				9	Fixed frequency 1 (FF1)	
				10	Fixed frequency 2 (FF2)	
				11	Fixed frequency 3 (FF3)	
				12	Fixed frequency 4 (FF4)	
				13	Fixed frequency 5 (FF5)	
				14	Fixed frequency 6 (FF6)	
				15	Fixed frequency 7 (FF7)	
				16	Fixed frequency 8 (FF8)	
P9-11	911	–	rw		Source - speed 2 like P9-10	2

PNU	ID	Access right		Value	Description	DS
		RUN	ro/rw			
P9-12	912	–	rw		Source - speed 3 like P9-10	0
P9-13	913	–			Source - speed 4 like P9-10	0
P9-14	914	–	rw		Source - speed 5 like P9-10	0
P9-15	915	–	rw		Source - speed 6 like P9-10	0
P9-16	916	–	rw		Source - speed 7 like P9-10	0
P9-17	917	–	rw		Source - speed 8 like P9-10	0
P9-18	918	–	rw		Speed - input 0 like P9-02	3
P9-19	919	–	rw		Speed - input 1 like P9-02	0
P9-20	920	–	rw		Speed - input 2 like P9-02	0
P9-21	921	–	rw		Fixed frequency 0 like P9-02	5
P9-22	922	–	rw		Fixed frequency 1 like P9-02	0
P9-23	923	–	rw		Fixed frequency 2 like P9-02	0
P9-24	924	–	rw		Acceleration ramp input 0 like P9-02	0
P9-25	925	–	rw		Acceleration ramp input 1 like P9-02	0
P9-26	926	–	rw		Deceleration time input 0 like P9-02	0
P9-27	927	–	rw		Deceleration time input 1 like P9-02	0
P9-28	928	–	rw		Control source - Up-pushbutton like P9-02	0
P9-29	929	–	rw		Control source - Down-pushbutton like P9-02	0
P9-30	930	–	rw		FWD limit switch like P9-02	0

6 Parameters

PNU	ID	Access right		Value	Description	DS
		RUN	ro/rw			
P9-31	931	–	rw		REV limit switch like P9-02	0
P9-32	932	–			reserved	0
P9-33	933	–	rw		Control source - analog output 1 (AO1)	0
				0	Value from P2-11	
				1	User Analog Output 1 (Digital)	
P9-34	934	–	rw	2	User Analog Output 1 (Analog)	
					Source - analog output 2 (AO2)	0
				0	Value from P2-13	
P9-35	935	–	rw	1	User Analog Output 1 (Digital)	
				2	User Analog Output 1 (Analog)	
					Control source - Relay 1	0
P9-36	936	–	rw	0	Value from P2-15	
				1	From internal PLC program	
					Control source - Relay 2	0
P9-37	937	–	rw	0	Value from P2-18	
				1	user-definable (PLC)	
					Control source - scaling	0
P9-38	938	–	rw	0	Value from P2-22	
				1	From internal PLC program	
					Source - PID setpoint value	0
P9-39	939	–	rw	0	Value from P3-05	
				1	user-definable	
					Source - PID feedback	0
P9-40	940	–	rw	0	Value from P3-10	
				1	From internal PLC program	
					Source - torque control reference	0
P9-41	941	–	rw		Function choices - Relay output 3, 4, 5	0
				0	Relay 1 → Variable frequency drive OK	
					Relay 2 → Variable frequency drive tripped	
					Relay 3 → Variable frequency drive released	
	1	From internal PLC program				

PNU	ID	Access right		Value	Description	DS
		RUN	ro/rw			
Parameter group P0 – Monitor						
P0-01	1				Analog input 1	%
					Displays the level of the signal level applied to analog input 1 (AI1, terminal 6) after scaling and offsets have been applied.	
P0-02	2				Analog input 2 (AI2)	%
					Displays the level of the signal level applied to analog input 2 (AI2, terminal 10) after scaling and offsets have been applied.	
P0-03	3				Digital inputs 1 - 5; status DI1, DI2, DI3, DI4 DI5	00000
					Displays the status of the variable frequency drive digital and analog inputs, including those available on the optional extended I/O module (DXA-EXT-3DI1RO). The value on the starting with the left hand side digit is digital input 1 (DI1).	
P0-04	4				Frequency reference value	Hz
					Displays the set point reference input applied to the drive internal speed controller.	
P0-05	5				Torque setpoint value	%
					Displays the set point reference input applied to the drive internal torque controller.	
P0-06	6				Digital speed reference value (motor potentiometer)	Hz
					Displays the value of the drive internal Motorised Pot (used for keypad) speed reference.	
P0-07	7				Field bus communication reference speed	Hz
					Displays the setpoints being received by the drive via the currently active field bus interface.	
P0-08	8				PID setpoint value	%
					Displays the setpoint input to the PID controller.	
P0-09	9				PID feedback	%
					Displays the Feedback input signal to the PID controller	
P0-10	10				PID Output	%
					Displays the output level of the PID controller	
P0-11	11				Motor voltage	V
					Displays the instantaneous output voltage from the variable frequency drive to the motor	
P0-12	12				Output torque (calculated value)	%
					Displays the instantaneous output torque level produced by the motor	
P0-13	13				Fault log	
					Displays the variable frequency drive's last four error codes. See the Faults section for more information.	
P0-14	14				Magnetizing current (I _d)	A
					Displays the motor magnetizing current, provided that an auto tune has been successfully completed.	

6 Parameters

PNU	ID	Access right		Value	Description	DS
		RUN	ro/rw			
P0-15	15				Rotor current (I_q)	A
					Displays the motor Rotor (torque producing) current, provided that an auto tune has been successfully completed.	
P0-16	16				DC link voltage ripple	V
					Displays the level of ripple present on the DC bus voltage. This parameter is used by the drive for various internal protection and monitoring functions.	
P0-17	17				Stator resistance (R_s)	Ω
					Displays the measured motor stator resistance, provided that an auto tune has been successfully completed.	
P0-18	18				Stator inductance	H
					Displays the measured motor stator inductance, provided that an auto tune has been successfully completed.	
P0-19	19				Rotor resistance	Ω
					Displays the measured motor rotor resistance, provided that an auto tune has been successfully completed.	
P0-20	20				The variable frequency drive's current DC link voltage	V
P0-21	21				Unit Temperature	$^{\circ}\text{C}$
					Displays the measured instantaneous heatsink temperature of the variable frequency drive.	
P0-22	22				Remaining time until servicing is required	h
					Displays the value of P6-24 minus the variable frequency drive's operating time.	
P0-23	23				Time heat sink temperature > 85 $^{\circ}\text{C}$	HH:MM:SS
					Displays the amount of time in hours and minutes for which the drive has been operating during its lifetime, where the heatsink temperature has been in excess of 85 $^{\circ}\text{C}$. This parameter is used by the drive for various internal protection and monitoring functions.	
P0-24	24				Operating time at ambient temperature > 85 $^{\circ}\text{C}$	HH:MM:SS
					Displays the total accumulated time in hours and minutes for which the drive has been operating with the internal ambient temperature in excess of 80 $^{\circ}\text{C}$. This parameter is used by the drive for various built-in protection and monitoring functions.	
P0-25	25				Motor shaft speed (calculated value in rpm)	rpm
					In vector control mode, this parameter displays either the estimated rotor speed of the motor if no encoder feedback is present, or the measured rotor speed if the optional Encoder feedback interface Option is fitted.	
P0-26	26				kWh-meter, up to 1000 kWh then P0-27 on 1	kWh
					Displays the energy consumed by the drive, in kWh. The first value shows the energy consumed since the counter was last reset. The second value shows the total energy consumed since the unit was made. If the value reaches 1,000 kWh, the counter will be reset to 0.0 and the value in P0-27 (MWh counter) will be incremented by 1.	

PNU	ID	Access right		Value	Description	DS
		RUN	ro/rw			
P0-27	27				MWh counter, P0-26 = 1000 → P0-27 = 1	MWh
					Displays the energy consumed by the drive, in MWh. The first value shows the energy consumed since the counter was last reset. The second value shows the total energy consumed since the unit was made.	
P0-28	28				Software version and checksum of the drive	
P0-29	29				Type details of the drive	
P0-30	30				Serial number of the drive	
P0-31	31				Operating time after default settings	HH:MM:SS
					Displays the total operating time of the drive since the date of manufacture in Hours, Minutes and Seconds. Pressing the Up key on the drive keypad will change the display from "Hours" to "Minutes and Seconds".	
P0-32	32				Operating time since the last trip 1	HH:MM:SS
					Displays the total operating time of the drive since the last Trip or Power down occurred in Hours, Minutes and Seconds. Pressing the Up key on the drive keypad will change the display from "Hours" to "Minutes and Seconds"	
P0-33	33				Operating time since the last trip 2	HH:MM:SS
					Displays the total operating time of the drive since the last Trip occurred in Hours, Minutes and Seconds. Pressing the Up key on the drive keypad will change the display from "Hours" to "Minutes and Seconds"	
P0-34	34				Operating time after last enable	HH:MM:SS
					Displays the total operating time of the drive since the last drive Enable signal was applied. Pressing the Up key on the drive keypad will change the display from "Hours" to "Minutes and Seconds".	
P0-35	35				Runtime of the fan	HH:MM:SS
					Displays the total operating time of the drive's integrated cooling fan in hours, minutes, and seconds. Pressing the Up key on the drive keypad will change the display from "Hours" to "Minutes and Seconds".	
P0-36	36				DC bus voltage log (256 ms)	
					DC Bus voltage log, recording the most recent 8 samples of the DC bus voltage prior to a drive trip condition occurring. The sample interval is 256 ms.	
P0-37	37				DC bus voltage ripple log (20 ms)	
					DC Bus voltage ripple log, recording the most recent 8 samples of the DC bus voltage ripple prior to a drive trip condition occurring. The sample interval is 20 ms.	
P0-38	38				Heatsink temperature log (30 s)	
					Heatsink temperature log, recording the most recent 8 samples of the heatsink temperature prior to a drive trip condition occurring. The sample interval is 30 s.	

6 Parameters

PNU	ID	Access right		Value	Description	DS
		RUN	ro/rw			
P0-39	39				Protocol of ambient air temperature (30 s)	
					Ambient temperature log, recording the most recent 8 samples of the drive internal ambient temperature prior to a drive trip condition occurring. The sample interval is 30 s.	
P0-40	40				Motor current log (256 ms)	
					Motor current log, recording the most recent 8 samples of the Motor current prior to a drive trip condition occurring.	
P0-41	41				FLT counter, overcurrent	
					Displays the number of overcurrent (O-I) trips which have occurred since the date of manufacture	
P0-42	42				FLT counter, overvoltage	
					Displays the number of Over-voltage (O-Volt) trips which have occurred since the date of manufacture	
P0-43	43				FLT counter, undervoltage	
					Displays the number of undervoltage (U-Volt) trips which have occurred since the date of manufacture	
P0-44	44				FLT counter, overtemperature	
					Displays the number of Heatsink overtemperature (O-t) trips which have occurred since the date of manufacture	
P0-45	45				FLT counter, braking transistor, overcurrent	
					Displays the number of brake chopper short-circuit (b O-I) trips which have occurred since the date of manufacture	
P0-46	46				FLT counter, ambient temperature	
					Displays the number of drive internal ambient overtemperature (O-t) trips which have occurred since the date of manufacture.	
P0-47	47				I/O communication fault meter	
					Displays the number of communication errors detected by the I/O processor in messages received from the power stage processor since the last power up.	
P0-48	48				DSP communication fault meter	
					Displays the number of communication errors detected by the Power Stage processor in messages received from the I/O processor since the last power up.	
P0-49	49				FLT counter, Modbus RTU communication	
					Displays the number of communication errors detected by the I/O processor in messages received on the Modbus channel since the last power up.	
P0-50	50				FLT counter, CANopen communication	
					Displays the number of communication errors detected by the I/O processor in messages received on the CANbus channel since the last power up.	
P0-51	51				reserved	
P0-52	52				reserved	

PNU	ID	Access right		Value	Description	DS
		RUN	ro/rw			
P0-53	53				U phase shift	
					L1 phase current offset and reference	
P0-54	54				V phase shift	
					L2 phase current offset and reference	
P0-55	55				reserved	
P0-56	56				Braking chopper - maximum "on" time	
					Displays the maximum Chopper closing delay in ms and the duty cycle ratio	
P0-57	57				U_d/U_q	
P0-58	58				Measured encoder speed	Hz
					Displays the measured encoder speed in Hz or rpm, if the encoder option module (DXA-EXT-ENCOD) is fitted and enabled.	
P0-59	59				Frequency input speed reference value	Hz
P0-60	60				Calculated slip speed in Hz or rpm	Hz
P0-61	61				Speed boost for hoisting gear	Hz
					Displays the boost speed applied in Hoist control mode	
P0-62	62				Droop speed in Hz or rpm	Hz
P0-63	63				Speed reference value post ramp	Hz
					Displays the post ramp speed reference in Hz or rpm.	
P0-64	64				Current switching frequency	kHz
					Displays the current RMS switching frequency. This frequency can be lower than the value set in P2-24 if reduced by the thermal feedback function (enabled in P6-02).	
P0-65	65				Lifespan of the variable frequency drive	HH:MM:SS
					Displays the time for which the drive has been powered up in Hours, Minutes and Seconds since date of manufacture	
P0-66	66				ID of the PLC program	0
					Displays the program ID of the user's PLC program. The user can specify this ID in the "drivesConnect" computer program while in PLC program mode.	
P0-67	67				Field bus torque setpoint value	
					Displays the field bus interface's torque reference value.	
P0-68	68				User ramp value	
					Displays the user ramp value received by the field bus interface. This ramp function will only be enabled if P5-07 = 1 (enabled).	
P0-69	69				I2C error counter	
					Displays the I2C error counter value since last power up.	
P0-70	70				Module identification code	
					Identification code of the module	

6 Parameters

PNU	ID	Access right		Value	Description	DS
		RUN	ro/rw			
P0-71	71				ID of the field bus	
					Fieldbus module Identification Code	
P0-72	72				Ambient air temperature	°C
					Displays the variable frequency drive's internal temperature.	
P0-73	73				The variable frequency drive's operating time	00:00
					Displays the value of the internal 24-hour counter in hours and minutes. This value can be configured with the drive's keypad (pressing up and down while the drive is stopped) and is reset to 0 when the drive is started.	
P0-74	74				Input voltage at L1	V
P0-75	75				Input voltage at L2	V
P0-76	76				Input voltage at L3	V
P0-77	77				Encoder count	
					The two values (high and low words) contain the 32-bit pulse count of the encoder input.	
P0-78	78				Test parameter 3/4	
P0-79	79				I/O bootloader and motor control version	
					Displays the bootloader version and motor control library version.	
P0-80	80				Selected internal parameter value	
					Displays the value selected with P6-28. Usually used in conjunction with the PLC function.	

6.1 Operating unit

The following figure shows the elements of the DA1 variable frequency drive integrated operating unit.

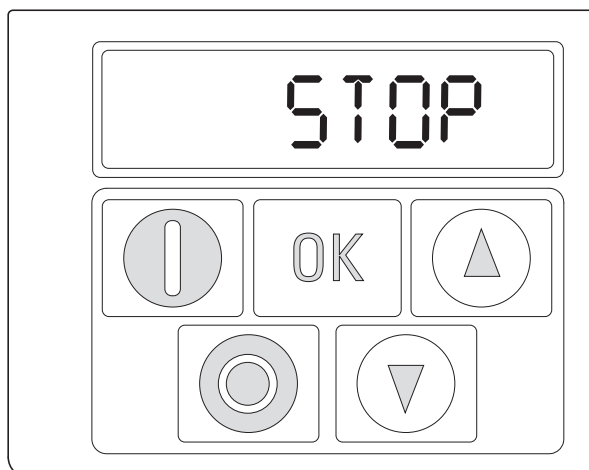
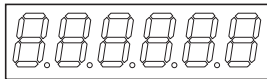
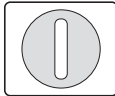
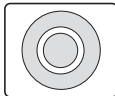

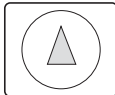
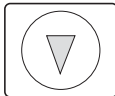

Figure 49: Operating unit view

Table 11: Operating unit elements

Operating unit element	Explanation
	Six-digit 7-segment LED display
	<p>Motor starter with pre-selected operating direction if parameter P1-12 = 1 (FWD) or P1-12 = 2 (FWD / REV).</p> <p>Notes:</p> <ul style="list-style-type: none"> • Enable with +24 V on control signal terminal 2 (D11) • P1-12 = 2: The first time it is pressed (commissioning, parameter reset), a clockwise rotating field (FWD) will always be activated. Only after it is pressed for a second time will the direction of the rotating field change to a counterclockwise rotating field (REV). (This setting will be retained even after the supply voltage is switched off.)
	<ul style="list-style-type: none"> • Stops the running motor if P1-12 = 1 or P1-12 = 2 • Reset – Resetting after an error message
	<ul style="list-style-type: none"> • Activate parameter input (editing mode) • Activate parameter value, change (display value flashes) • Confirm (store) and activate configured value
	<ul style="list-style-type: none"> • Increment numeric value or parameter number • Increase output frequency / motor speed if P1-12 = 1 or P1-12 = 2
	<ul style="list-style-type: none"> • Decrement numeric value or parameter number • Reduce output frequency / motor speed if P1-12 = 1 or P1-12 = 2

6 Parameters

6.1 Operating unit

6.1.1 Display unit

The display unit is a 7-segment LED display with five decimal points. The LED segments are red.

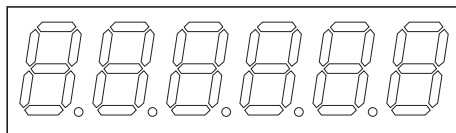

Figure 50: 7-segment LED display

6.1.2 Menu Navigation

When the specified supply voltage (L1/L, L2/N, L3 connection terminals) is applied, the DA1 variable frequency drive will automatically perform a self-test: The LED display will light up and, depending on the selected operating mode, will display *StoP* or the appropriate value.



When operating values are displayed (i.e. *StoP* is not displayed), the variable frequency drive will issue an automatic start command.

6.1.3 Setting parameters

The following table shows a good example of the general execution for selecting and setting parameters.



The flashing digit on the right indicates that the value being displayed can be changed with the arrow buttons (Up ▲ or Down ▼).

Sequence	Commands	Indicator	Description
0			Stop status: The variable frequency drive is ready for operation.
1			Hold down the OK button for about a second. Parameter P1-01 will be displayed (the digit on the right, "1", will flash) Press OK button The display will switch to H 50.0 (= 50 Hz), the digit on the right, "0", will flash. The value can be confirmed and automatically stored by pressing the OK pushbutton. The display will jump back to the parameter designation (P1-01).
2			The numerical first value is always shown from the selected main menu. Example: PAR main menu, parameter P1-01



Activate and save your changes with the OK pushbutton.

6.1.4 Parameter selection

Parameter P-14 is used to select between a limited range of parameters (P1-14 = 0), the advanced parameters (P1-14 = P2-40, DS = 101), or all parameters (P1-14 = P6-30, DS = 201).

Parameter P2-40 or P6-30 is used to change the access code used to access all the parameters. Once you confirm parameter P2-40 or P6-30, the reduced parameters will be locked.

You can use parameter P2-39 to block access to all parameters, with the exception of parameter P1-14 (read-only).

6 Parameters

6.2 Digital and analog inputs

6.2 Digital and analog inputs

Parameter P1-13 is used to configure the mode of operation and function of both the digital and analog inputs (Table 12, page 133). The configured value will depend on parameter P1-12.

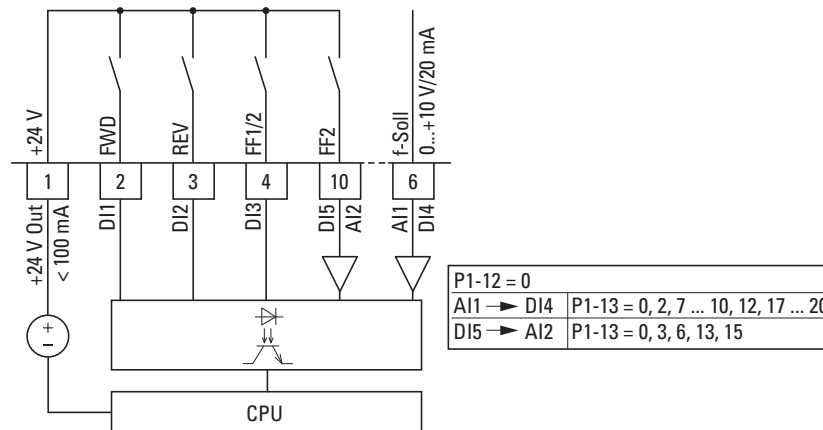

Figure 51: Digital and analog inputs

The operation of the DA1 variable frequency drive via control signal terminals (P1-12 = 0, P1-13 = 11) is active with default settings:

- DI1 (control signal terminal 2):
FWD (Start enable clockwise rotating field)
- DI2 (control signal terminal 3):
REV (Start enable anti-clockwise rotating field)
- DI3 (control signal terminal 4):
FF1 or FF2 (switching between setpoint sources)
- AI1/DI4 (control signal terminal 6): analog setpoint input (0 - 10 V)
- DI5/AI2 (control signal terminal 10):
FF1 or FF2 (switching between fixed frequency 1 (FF1 = P2-01, DS = 5 Hz) and fixed frequency 2 (FF2 = P2-02, DS = 10 Hz))

When control signal terminal 2 (FWD) and control signal terminal 3 (REV) are activated at the same time, the default settings will activate quick stop dec2 (P2-25).

6 Parameters

6.2 Digital and analog inputs

Table 12: Parameter P1-13 configuration

P1-13	DI1	DI2	DI3	AI1/DI 5	DI4/AI2	Fixed frequencies
0	user-definable	user-definable	user-definable	user-definable	user-definable	
1	0 = Stop 1 = Run	0 = Forward 1 = Reverse	0 = Selected setpoint source 1 = Fixed frequency 1/2	AI 1 setpoint value	0 = Fixed frequency 1 1 = Fixed frequency 2	
2	0 = Stop 1 = Run	0 = Forward 1 = Reverse	0	0	0	FF 1
			1	0	0	FF 2
			0	1	0	FF 3
			1	1	0	FF 4
			0	0	1	FF 5
			1	0	1	FF 6
			0	1	1	FF 7
			1	1	1	FF 8
3	0 = Stop 1 = Run	0 = Forward 1 = Reverse	0 = Selected setpoint source 1 = Fixed frequency 1	Setpoint value AI1	Analog torque control reference	
4	0 = Stop 1 = Run	0 = Forward 1 = Reverse	0 = Selected setpoint source 1 = Fixed frequency 1	Setpoint value AI1	0 = Deceleration time 1 1 = Deceleration time 2	
5	0 = Stop 1 = Run	0 = Forward 1 = Reverse	0 = Selected setpoint source 1 = Analog input 2	Setpoint value AI1	Setpoint value AI2	
6	0 = Stop 1 = Run	0 = Forward 1 = Reverse	0 = Selected setpoint source 1 = Fixed frequency 1	Setpoint value AI1	External fault 0 = Fault 1 = Run	
7	0 = Stop 1 = Run	0 = Forward 1 = Reverse	0	0	External fault 0 = Fault 1 = Run	FF 1
			1	0		FF 2
			0	1		FF 3
			1	1		FF 4
8	0 = Stop 1 = Run	0 = Forward 1 = Reverse	0	0	0 = Deceleration time 1 1 = Deceleration time 2	FF 1
			1	0		FF 2
			0	1		FF 3
			1	1		FF 4
9	0 = Stop 1 = Run	0 = Forward 1 = Reverse	0	0	0 = Selected setpoint source 1 = Fixed frequency 1 - 4	FF 1
			1	0		FF 2
			0	1		FF 3
			1	1		FF 4
10	0 = Stop 1 = Run	0 = Forward 1 = Reverse	1 = Increase setpoint value	1 = Decrease setpoint value	0 = Selected setpoint source 1 = Fixed frequency 1	
11	0 = Stop 1 = Run FWD	0 = Stop 1 = Run REV	0 = Selected setpoint source 1 = Fixed frequency 1 / 2	AI 1 setpoint value	0 = Fixed frequency 1 1 = Fixed frequency 2	

6 Parameters

6.2 Digital and analog inputs

P1-13	DI1	DI2	DI3	AI1/DI 5	DI4/AI2	Fixed frequencies
12	0 = Stop 1 = Run FWD	0 = Stop 1 = Run REV	0	0	0	FF 1
			1	0	0	FF 2
			0	1	0	FF 3
			1	1	0	FF 4
			0	0	1	FF 5
			1	0	1	FF 6
			0	1	1	FF 7
			1	1	1	FF 8
13	0 = Stop 1 = Run FWD	0 = Stop 1 = Run REV	0 = Selected setpoint source 1 = Fixed frequency 1	Setpoint value AI1	Analog torque control reference	
14	0 = Stop 1 = Run FWD	0 = Stop 1 = Run REV	0 = Selected setpoint source 1 = Fixed frequency 1	Setpoint value AI1	0 = Deceleration time 1 1 = Deceleration time 2	
15	0 = Stop 1 = Run FWD	0 = Stop 1 = Run REV	0 = Selected setpoint source 1 = Analog input 2	Setpoint value AI1	Setpoint value AI2	
16	0 = Stop 1 = Run FWD	0 = Stop 1 = Run REV	0 = Selected setpoint source 1 = Fixed frequency 1	Setpoint value AI1	External fault 0 = Fault 1 = Run	
17	0 = Stop 1 = Run FWD	0 = Stop 1 = Run REV	0	0	External fault 0 = Fault 1 = Run	FF 1
			1	0		FF 2
			0	1		FF 3
			1	1		FF 4
18	0 = Stop 1 = Run FWD	0 = Stop 1 = Run REV	0	0	0 = Deceleration time 1 1 = Deceleration time 2	FF 1
			1	0		FF 2
			0	1		FF 3
			1	1		FF 4
19	0 = Stop 1 = Run FWD	0 = Stop 1 = Run REV	0	0	0 = Selected setpoint source 1 = Fixed frequency 1 - 4	FF 1
			1	0		FF 2
			0	1		FF 3
			1	1		FF 4
20	0 = Stop 1 = Run FWD	0 = Stop 1 = Run REV	1 = Increase setpoint value	2 = Decrease setpoint value	0 = Selected setpoint source 1 = Fixed frequency 1	
21	Pushbutton: 1 = Run FWD	Pushbutton: 0 = Stop	Pushbutton: 1 = Run REV	AI 1 setpoint value	0 = Selected setpoint source 1 = Fixed frequency 1	

6.2.1 Digital Input (DI)

Control signal terminals 2, 3, 4, 6 and 10 can be used as digital inputs (DI). The digital inputs' function and mode of operation are configured in parameter P1-13.

Example

Desired options:

- Clockwise rotating field (FWD)
- Anticlockwise rotating field (REV)
- a fixed frequency
- External fault
- Setpoint value via AI1

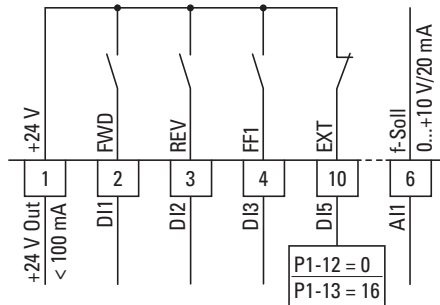

Figure 52: Example of an external fault (EXT)

Table 13: Digital input wiring (P1-12 = 0)

P1-13	DI1	DI2	DI3	DI5	AI1
16	0 = locked 1 = Start enable FWD	0 = locked 1 = Start enable REV	0 = Selected setpoint source 1 = Fixed frequency 1	external fault: 0 = Fault 1 = Enable	Setpoint value AI1 (0 - 10 V)
DI1 + DI2 = Quick stop (P-24)					

- DI1 (control signal terminal 2): FWD (Forward = Start enable clockwise rotating field)
- DI2 (control signal terminal 3): REV (Reverse = Start enable anti-clockwise rotating field)
- DI3 (control signal terminal 4): FF1 (fixed frequency 1)
- DI5 (control signal terminal 10): external fault
- AI1 (control signal terminal 6): analog setpoint value

6 Parameters

6.2 Digital and analog inputs

6.2.2 Analog Input (AI)

Control signal terminals 6 and 10 can be used as analog inputs (AI). The corresponding signal range will depend on parameter P2-30 for analog input AI1 and parameter P2-33 for analog input AI2.

The reference potential for the two analog inputs AI1 and AI2 is 0 V (control signal terminals 7 and 9).



The function of control signal terminals 6 and 10 is defined by the selection made in parameter P1-13 and depends on the control mode in parameter P1-12.

With the default settings, control signal terminal 6 (AI1) will be configured for a setpoint voltage of 0 to +10 V DC (P2-30) and control signal terminal 10 as a digital input (DI5).

Example

Desired options:

- Analog input AI2 suitable for 4 to 20 mA with wire breakage monitoring.
- Switching the setpoint source between AI1 and AI2 via DI3.

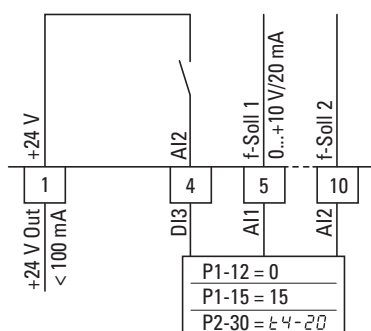

Figure 53: Switching setpoint sources

Table 14: Analog and digital input wiring (P1-12 = 0, P2-30 = 4-20)

P1-13	DI1	DI2	DI3	AI1	AI2
15	0 = locked 1 = Start enable FWD	0 = locked 1 = Start enable REV	0 = AI1 1 = AI2	Setpoint value AI1 (0 - 10 V)	Setpoint value AI2 (4 - 20 mA)

- DI1 (control signal terminal 2):
FWD (Forward = Start enable clockwise rotating field)
- DI2 (control signal terminal 3):
REV (Reverse = Start enable anti-clockwise rotating field)
- DI3 (control signal terminal 4):
AI1 / AI2 (change of setpoint source from AI1 to AI2)
- AI1 (control signal terminal 6): analog setpoint value 1
- AI2 (control signal terminal 10): analog setpoint value 2

6.2.2.1 Scaled value range (AI1/AI2)

The following graphs show examples of the curve characteristics of the scaled and non-scaled input signals.

Example: P2-31 = 200 %

If parameter P2-30 is configured for a 0 - 10 V signal and parameter P2-31 is set to 200 %, a 5 V input will result in the variable frequency drive running at its maximum frequency / speed (P1-01). Values lower than 100 % limit the maximum frequency; values greater than 100 % are used for low signal levels, e.g. for sensors with a 0 to 5 V output.

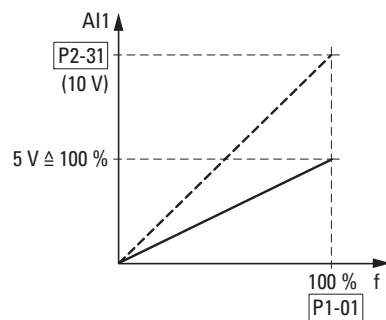

Figure 54: Scaled input signal

6 Parameters

6.2 Digital and analog inputs

6.2.2.2 Motor potentiometer

The function of an electronic motor potentiometer for entering setpoints can be set with parameters P1-12, P1-13 and P2-37.

Example

P1-12 = 1 or P1-12 = 2; P1-13 = 20; P2-37 = 4, 5, 6, 7

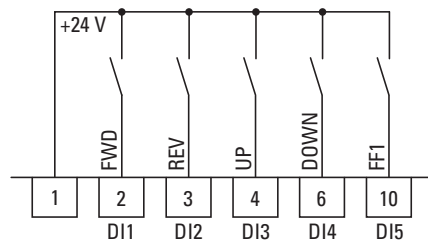

Figure 55: Motor potentiometer for both operating directions (FWD / REV)

A FWD start enable signal is issued when there is a solid contact at control signal terminal 2 (DI1); a REV start enable signal is issued when there is a solid contact at control signal terminal 3 (DI2).

The frequency reference value can then be increased with a control command (pulse) on terminal 4 (DI3) (UP). The acceleration will take place using the time set in P1-03 (acc1) all the way to the maximum output frequency set in P1-01.

Parameter P2-37 is used to define the behavior of the variable frequency drive in the event of a restart:

- P2-37 = 4: The DA1 variable frequency drive will start off from the minimum frequency (P-02).
- P2-37 = 5: The DA1 frequency reference value will store the set value and move to the previously set frequency reference value when starting. The frequency reference value set here will be retained even after the supply voltage is switched off.
- P2-37 = 6: The DA1 variable frequency drive will move to the current speed if the variable frequency drive is configured with multiple speed reference values.
- P2-37 = 7: The DA1 variable frequency drive will move to fixed frequency 8 (FF8) (P2-08).

Control signal terminal 6 (DI4) can be used to reduce the configured frequency reference value of the motor potentiometer (DOWN). The deceleration will take place using the time set in P1-04 (dec1) all the way to 0 Hz if a minimum frequency has not been set in P1-02.

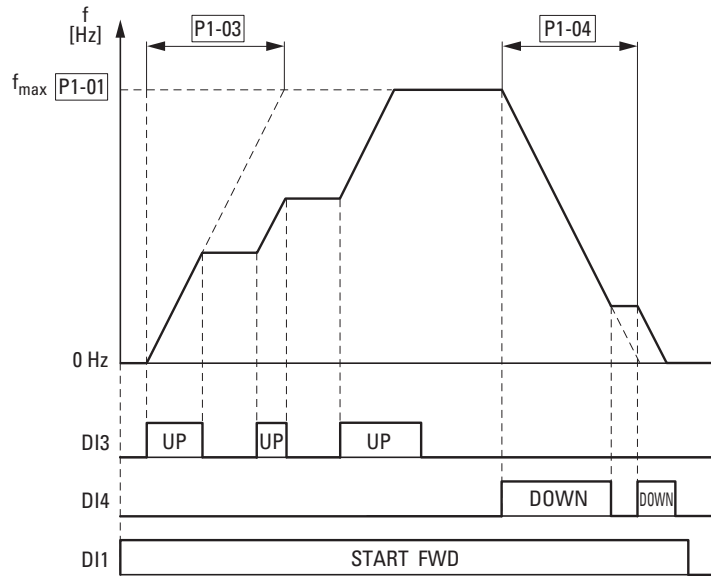

Figure 56: Motor potentiometer example

If a minimum frequency has been configured (P1-02), the motor potentiometer will always start at $f = 0$ Hz. After the configured minimum frequency is exceeded, the motor potentiometer will work within the range up to the maximum frequency (P1-01). The frequency will not fall below the minimum frequency value unless the start enable (DI1) is switched off.

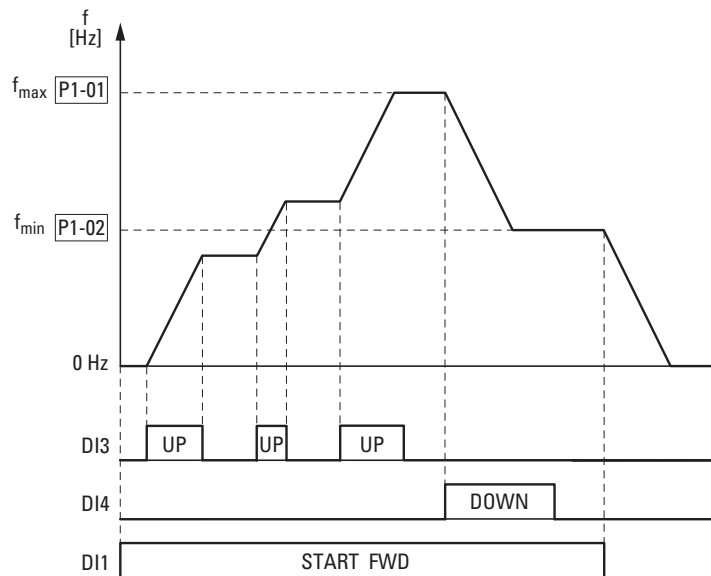

Figure 57: Motor potentiometer with f_{min} limit

6 Parameters

6.2 Digital and analog inputs

6.2.2.3 Two-wire control

The parameters must be set as follows for the so-called two-wire control:

P1-13	DI1	DI2	DI3	AI1/DI4	AI2/DI5	Notes
1	0 = Stop 1 = Run	0 = FWD 1 = REV	0 = Selected setpoint source 1 = Fixed frequency 1 or 2	AI 1 setpoint value	0 = Fixed frequency 1	
					1 = Fixed frequency 2	
2	0 = Stop 1 = Run	0 = FWD 1 = REV				
			0	0	0	Fixed frequency 1
			1	0	0	Fixed frequency 2
			0	1	0	Fixed frequency 3
			1	1	0	Fixed frequency 4
			0	0	1	Fixed frequency 5
			1	0	1	Fixed frequency 6
			0	1	1	Fixed frequency 7
1	1	1	Fixed frequency 8			
3	0 = Stop 1 = Run	0 = FWD 1 = REV	0 = Selected setpoint source 1 = Fixed frequency 1	AI 1 setpoint value	–	
4	0 = Stop 1 = Run	0 = FWD 1 = REV	0 = Selected setpoint source 1 = Fixed frequency 1	AI 1 setpoint value	0 = Deceleration time 1 1 = Deceleration time 2	
5	0 = Stop 1 = Run	0 = FWD 1 = REV	0 = Selected setpoint source 1 = Setpoint source 2	AI 1 setpoint value	Setpoint Source 2	
6	0 = Stop 1 = Run	0 = FWD 1 = REV	0 = Selected setpoint source 1 = Fixed frequency 1	AI 1 setpoint value	0 = External fault 1 = RUN	
7	0 = Stop 1 = Run	0 = FWD 1 = REV			0 = External fault	
			0	0	1 = RUN	Fixed frequency 1
			1	0		Fixed frequency 2
			0	1		Fixed frequency 3
1	1		Fixed frequency 4			
8	0 = Stop 1 = Run	0 = FWD 1 = REV			0 = External fault	
			0	0	1 = RUN	Fixed frequency 1
			1	0		Fixed frequency 2
			0	1		Fixed frequency 3
1	1		Fixed frequency 4			
9	0 = Stop 1 = Run	0 = FWD 1 = REV			0 = Setpoint value via AI1	
			0	0	1 = Fixed frequencies 1 - 4	Fixed frequency 1
			1	0		Fixed frequency 2
			0	1		Fixed frequency 3
1	1		Fixed frequency 4			
10	0 = Stop	0 = FWD	Motor potentiometer faster	Motor potentiometer slower	0 = Motor potentiometer	
	1 = Run	1 = REV			1 = Fixed frequency 1	

Example

P-12 = 0; P-15 = 0

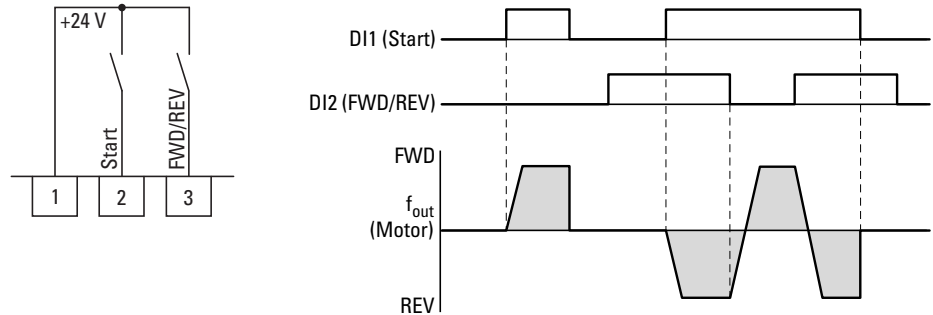

Figure 58: DI1 (Start), Two-wire control DI1 + DI2 = REV

The start enable via control signal terminal 3 (DI1) is always required for operation:

- Actuation control signal terminal 3 (DI1) = Start enable, clockwise rotating field (FWD)
- Actuation control signal terminal 3 (DI1) plus control signal terminal 4 (DI2) = Start enable anticlockwise rotating field (REV)

The separate actuation of control signal terminal 4 (DI2) does not allow any start enable.

PNU	ID	Access right		Value	Description	DS
		RUN	ro/rw			
P2-01	201	✓	rw		Fixed frequency FF1 / speed 1 P1-10 = 0 → -P1-02 - P1-01 → Hz P1-10 > 0 → -P1-02 - P1-01 x 60 s → rpm (1/min) 0.00 Hz (P1-02) up to the maximum frequency value (P1-01). Activation via digital inputs depending on parameters P1-12 and P1-13 according to the "Input value DA1" table.	5.0
P2-02	202	✓	rw		Fixed frequency FF2 / speed 2 P1-10 = 0 → -P1-02 - P1-01 → Hz P1-10 > 0 → -P1-02 - P1-01 x 60 s → rpm (1/min) 0.00 Hz (P1-02) up to the maximum frequency value (P1-01). Activation via digital inputs depending on parameters P1-12 and P1-13.	10.0
P2-03	203	✓	rw		Fixed frequency FF3 / speed 3 P1-10 = 0 → -P1-02 - P1-01 → Hz P1-10 > 0 → -P1-02 - P1-01 x 60 s → rpm (1/min) 0.00 Hz (P1-02) up to the maximum frequency value (P1-01). Activation via digital inputs depending on parameters P1-12 and P1-13.	25.0

6 Parameters

6.2 Digital and analog inputs

PNU	ID	Access right		Value	Description	DS
		RUN	ro/rw			
P2-04	204	✓	rw		Fixed frequency FF4 / speed 4 P1-10 = 0 → -P1-02 - P1-01 → Hz P1-10 > 0 → -P1-02 - P1-01 x 60 s → rpm (1/min) 0.00 Hz (P1-02) up to the maximum frequency value (P1-01). Activation via digital inputs depending on parameters P1-12 and P1-13.	50.0
P2-05	201	✓	rw		Fixed frequency FF5 / speed 5 P1-10 = 0 → -P1-02 - P1-01 → Hz P1-10 > 0 → -P1-02 - P1-01 x 60 s → rpm (1/min) 0.00 Hz (P1-02) up to the maximum frequency value (P1-01). Activation via digital inputs depending on parameters P1-12 and P1-13.	0.0
P2-06	206	✓	rw		Fixed frequency FF6 / speed 6 P1-10 = 0 → -P1-02 - P1-01 → Hz P1-10 > 0 → -P1-02 - P1-01 x 60 s → rpm (1/min) 0.00 Hz (P1-02) up to the maximum frequency value (P1-01). Activation via digital inputs depending on parameters P1-12 and P1-13.	0.0
P2-07	207	✓	rw		Fixed frequency FF7 / speed 7 P1-10 = 0 → -P1-02 - P1-01 → Hz P1-10 > 0 → -P1-02 - P1-01 x 60 s → rpm (1/min) 0.00 Hz (P1-02) up to the maximum frequency value (P1-01). Activation via digital inputs depending on parameters P1-12 and P1-13.	0.0
P2-08	208	✓	rw		Fixed frequency FF8 / speed 8 P1-10 = 0 → -P1-02 - P1-01 → Hz P1-10 > 0 → -P1-02 - P1-01 x 60 s → rpm (1/min) 0.00 Hz (P1-02) up to the maximum frequency value (P1-01). Activation via digital inputs depending on parameters P1-12 and P1-13.	0.0

6.2.2.4 Three-wire control

With the so-called three-wire control, the start and stop commands are set via spring-return switches (pulse) - similar to a contactor control.

The parameters must be configured as follows:

$P1-12 = 0 \rightarrow P1-13 = 21$

Example

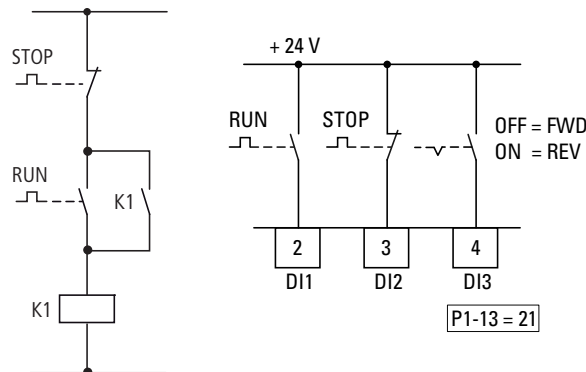

Figure 59: Example showing contactor control and three-wire control
Standard control section for a drive with spring-return switches (N/C, N/O) and latching:

If parameter $P1-13 = 21$, this control section can be recreated with control signal terminals 2 (DI1) and 3 (DI2), and control signal terminal 4 (DI3) can be used to activate an operating direction change (FWD \leftrightarrow REV) (reversing starter).

6 Parameters

6.2 Digital and analog inputs

6.2.3 Digital / analog outputs

DA1 series variable frequency drives have two digital/analog outputs and two relay outputs available with a variety of characteristics.

- Digital / analog output 1:
 - Transistor output DO1 (+24 V):
control signal terminals 8 and 9 (P2-11 = 0, ..., 7)
 - Analog output AO1: (0 - +10 VDC, max. 20 mA):
control signal terminals 8 and 9 (P2-11 = 8, ..., 11)
- Digital / analog output 2:
 - Transistor output DO2 (+24 V):
control signal terminals 9 and 11 (P2-13 = 0, ..., 7)
 - Analog output AO2: (0 - +10 VDC, max. 20 mA):
control signal terminals 9 and 11 (P2-13 = 8, ..., 11)
- Relay output K1 (250 V, 6 A AC / 30 V 5 A DC)
changeover contacts, control signal terminals 14, 15, 16 (P2-15)
- Relay output K2 (250 V, 6 A AC / 30 V 5 A DC)
N/O contacts, control signal terminals 17, 18 (P2-18)

In the default settings (P2-11 = 8), the analog output's voltage signal (0 - 10 V; P2-12) will be proportional to output frequency $f_{\text{Out}} = 0 - f_{\text{max}} (P1-01)$.



The output signals of control signal terminals 8 and 11 (AO1 and AO2) are not monitored by the variable frequency drive.

Example

Desired options:

- Relay output K1 should output an alarm message if there is a 10 % over-current.
- Analog output AO2 should show the rated motor current within a range of 0 to 10 V for more precise monitoring (5 V = motor rated current (P1-08)).

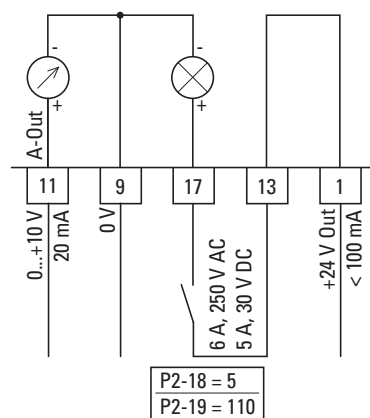

Figure 60: Example: Overcurrent monitor

If the motor ($I_e = 1.9 \text{ A}$) from → Section 6.2.8, “Motor” is used as an example, relay K1 will switch as soon as the motor draws a current of 2.09 A. The analog output will output a voltage of 5.5 V.

The variable frequency drive will then switch off automatically due to an overload ($I_e > 100 \%$). The following error message will be displayed: $I.L - LrP$

PNU	ID	Access right		Value	Description	DS
		RUN	ro/rw			
P2-11	211	✓	rw		A01 signal	8
					Digital output → +24 V DC	
				0	RUN, enable (FWD, REV)	
				1	READY, ready for operation	
				2	Output frequency = frequency reference value	
				3	Output frequency > zero speed	
				4	Output frequency closing threshold > P2-16 Switch off threshold < P2-17	
				5	Output current closing threshold > P2-16 Switch off threshold < P2-17	
				6	Output torque closing threshold > P2-16 Switch off threshold < P2-17	
				7	AI2 signal level closing threshold > P2-16 Switch off threshold < P2-17	
					Analog output → P2-12	
					Output frequency f-Out → 0 - 100 % f_{max} (P1-01)	
	Output current → 0 - 200 % I_e (P1-08)					
	Torque M_N → 0 - 200 % (calculated value)					
	Output power P_N → 0 - 150 % (I_e)					
P2-12	212	✓	rw		A01, signal range	UD - 10
				UD - 10	0 - 10 V	
				U 10 - 0	10 - 0 V	
				RD - 20	0 - 20 mA	
				R20 - 0	20 - 0 mA	
				R4 - 20	4 - 20 mA	
				R20 - 4	20 - 4 mA	

6 Parameters

6.2 Digital and analog inputs

PNU	ID	Access right		Value	Description	DS
		RUN	ro/rw			
P2-13	213	✓	rw		AO1 signal	9
					Analog output → 0 - 10 V DC	
				8	Output frequency f-Out → 0 - 100 % f _{max} (P1-01)	
				9	Output current → 0 - 200 % I _e (P1-08)	
				10	Torque M _N → 0 - 200 % (calculated value)	
				11	Output power P _N → 0 - 150 % (I _e)	
					Digital output → +24 V DC	
				0	RUN, enable (FWD, REV)	
				1	READY, ready for operation	
				2	Output frequency = frequency reference value	
				3	Output frequency > zero speed	
				4	Output frequency closing threshold > P2-19 Switch off threshold < P2-20	
				5	Output current closing threshold > P2-19 Switch off threshold < P2-20	
				6	Output torque closing threshold > P2-19 Switch off threshold < P2-20	
7	AI2 signal level closing threshold > P2-19 Switch off threshold < P2-20					
P2-14	214	✓	rw		AO1, signal range	UD - 10
				UD - 10	0 - 10 V	
				U 10 - 0	10 - 0 V	
				RD - 20	0 - 20 mA	
				R 20 - 0	20 - 0 mA	
				R 4 - 20	4 - 20 mA	
				R 20 - 4	20 - 4 mA	

6 Parameters

6.2 Digital and analog inputs

PNU	ID	Access right		Value	Description	DS
		RUN	ro/rw			
P2-15	215	✓	rw		K1 signal (Relay Output 1)	1
					Used to select the function assigned to the relay output. The relay has three output terminals (changeover contacts): Logic 1 indicates that the relay is active: This is why terminals 14 and 15 are connected to each other.	
				0	RUN, enable (FWD, REV)	
				1	READY, ready for operation	
				2	Output frequency = frequency reference value	
				3	Output frequency > 0 Hz	
				4	Output Frequency Closing threshold > P2-16 Switch off threshold < P2-17	
				5	Output current Closing threshold > P2-16 Switch off threshold < P2-17	
				6	Output torque (calculated value) Closing threshold > P2-16 Switch off threshold < P2-17	
	7	Analog input (AI) 2 Closing threshold > P2-16 Switch off threshold < P2-17				
P2-16	216	✓	rw		A01/K1 upper limit	100.0
					The adjustable upper limit value that is being used in connection with settings 4 to 7 of P2-11 and P2-15	
					0.0 - 200.0 %	
P2-17	217	✓	rw		A01/K1 lower limit	0.0
					The adjustable lower limit value that is being used in connection with settings 4 to 7 of P2-11 and P2-15	
					0.0 - 200.0 %	

6 Parameters

6.2 Digital and analog inputs

PNU	ID	Access right		Value	Description	DS
		RUN	ro/rw			
P2-18	218	✓	rw		K2 signal (Relay Output 2)	0
					Used to select the function assigned to the relay output. The relay has two output terminals: Logic 1 indicates that the relay is active: This is why terminals 17 and 18 are connected to each other.	
				0	RUN, enable (FWD, REV)	
				1	READY, variable frequency drive ready for operation	
				2	Output frequency = frequency reference value	
				3	Output frequency > 0 Hz	
				4	Output Frequency Closing threshold > P2-16 Switch off threshold < P2-17	
				5	Output current Closing threshold > P2-16 Switch off threshold < P2-17	
				6	Output torque (calculated value) Closing threshold > P2-16 Switch off threshold < P2-17	
				7	Analog input (AI) 2 Closing threshold > P2-16 Switch off threshold < P2-17	
	8	PLC for external (hub) brake. This setting also enables the special operating mode for hoisting gear. Please contact your sales office for details.				
P2-19	219	✓	rw		A02/K2 upper limit	100.0
					The adjustable upper limit value that is being used in connection with settings 4 to 7 of P2-13 and P2-18	
					0.0 - 200.0 %	
P2-20	220	✓	rw		A02/K2 lower limit	0.0
					The adjustable lower limit value that is being used in connection with settings 4 to 7 of P2-13 and P2-18	
					0.0 - 200.0 %	

6.2.4 Drives control

Parameter group P1-12 can be used to define the control level for the DA1 variable frequency drive.



If the control level changes, the inputs' mode of operation and function (P1-13) via the control signal terminals will change.

6.2.5 Second acceleration and deceleration time

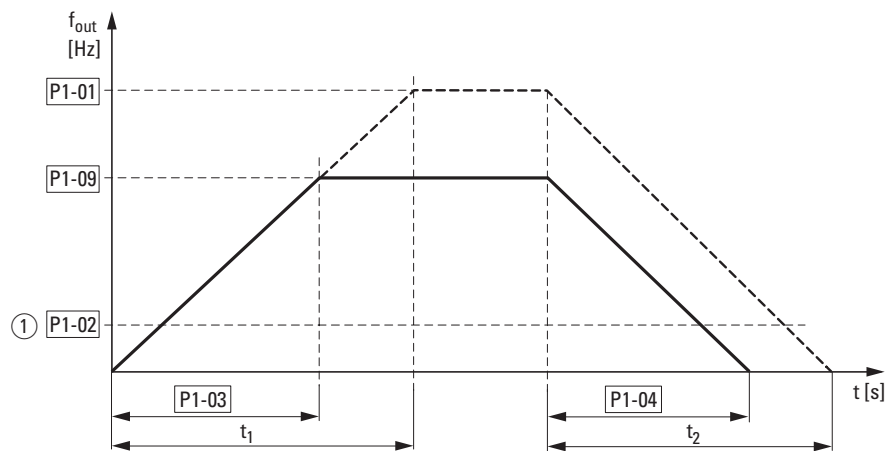

Figure 61: Acceleration and deceleration time
0 Hz (P1-02) and the maximum output frequency f_{max} (P1-01) are always reference points for the acceleration and deceleration times set in parameters P1-03 and P1-04.
① If a minimum output frequency (P1-02 > 0 Hz) is set, the drive's acceleration and deceleration times will be reduced to t_1/t_2 .

The values for the acceleration time t_1 and the deceleration time t_2 are calculated as follows:

$$t_1 = \frac{(P1-01 - P1-02) \times P1-03}{P1-01}$$

$$t_2 = \frac{(P1-01 - P1-02) \times P1-04}{P1-01}$$



The defined acceleration (P1-03) and deceleration times (P1-04) apply for all changes to the frequency reference value. If the start-release (FWD, REV) is switched off, the output frequency (f_{Out}) is immediately set to zero. The motor runs down uncontrolled. If a controlled run-down is requested (with value from P1-04), parameter P1-05 must be 0. Starting friction and load inertia can lead to longer acceleration times for the drive than those configured in P1-03. Large gyrating masses and the load being driven can lead to longer deceleration times for the drive than that configured in P1-04.

6 Parameters

6.2 Digital and analog inputs

6.2.6 Frequency jump

In systems with mechanical resonances, you can skip this frequency range for stationary operation.

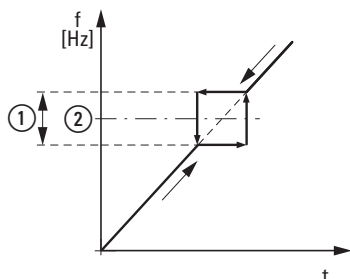

Figure 62: Setting range for frequency masking

- ① P2-10
- ② P2-09

PNU	ID	Access right		Value	Description	DS
		RUN	ro/rw			
P2-09	209	✓	rw		Frequency skip 1, bandwidth (hysteresis range) 0.00 - P1-01 (f_{max})	0
P2-10	210	✓	rw		Frequency skip 1, center P1-02 (f_{min}) - P1-01 (f_{max}) The skip frequency function is used to prevent the variable frequency drive from being run at a specific output frequency, e.g. at a frequency that will cause mechanical resonance in a specific machine. Parameter P2-10 is used to define the center of the skip frequency band and is used together with parameter P2-09. The output frequency will run through the specified band at the speeds set in P1-03 or P1-04 without holding an output frequency that falls within the defined band. If the frequency reference value applied to the variable frequency drive falls within the band, the output frequency will remain at the upper or lower limit of the band.	0

6.2.7 Start Function

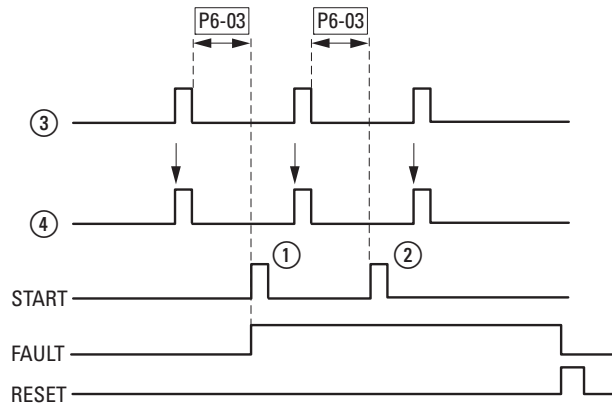

Figure 63: Automatic restart after error message (two start attempts)

- ① First automatic restart
- ② Second automatic restart
- ③ Switch-off when error detected
- ④ Motor Stop Signal
TEST = monitored test time
FAULT = shut-off when error message occurs
RESET = reset error message (FAULT)

PNU	ID	Access right		Value	Description	DS
		RUN	ro/rw			
P2-36	236	✓	rw		REAF, Start function with automatic restart	Ed9E-r
					Used to define the variable frequency drive's behavior concerning the enable digital input and to configure the automatic restart function.	
				Ed9E-r	Deactivated	
					(the variable frequency drive will need a new start edge) : After being switched on, as well as after a reset, the variable frequency drive will not start if digital input 1 remains closed. The input must be closed after switching on, as well as after a reset, in order to start the variable frequency drive.	
				RUt0-0	The variable frequency drive will start automatically (The variable frequency drive does not need a start edge; the signal will continue to be applied). After being switched on, as well as after a reset, the variable frequency drive will start automatically if digital input 1 is closed.	
				RUt0-1	The variable frequency drive will start automatically once. After a trip, the variable frequency drive will make up to five attempts to restart at 20-second intervals. The variable frequency drive must be de-energized in order to reset the counter. The number of restart attempts is counted. If the variable frequency drive does not start after the last attempt, it will switch to an error condition and request the user to reset the error manually.	
				RUt0-2	The variable frequency drive will start automatically twice.	
				RUt0-3	The variable frequency drive will start automatically three times.	
				RUt0-4	The variable frequency drive will start automatically four times.	
				RUt0-5	The variable frequency drive will start automatically five times.	

6 Parameters

6.2 Digital and analog inputs

PNU	ID	Access right		Value	Description	DS
		RUN	ro/rw			
P2-37	237	✓	rw		REAF, Start function with automatic restart, operating unit	1
					This parameter will only be active if the keypad control operating mode is being used (P-12 = 1 or 2).	
				0	Minimum speed; keypad The keypad's start and stop pushbuttons are enabled, and control signal terminals 1 and 2 must be connected. The variable frequency drive will always start with the minimum frequency/speed (P1-02).	
				1	Previous speed, keypad The keypad's start and stop pushbuttons are enabled; control signal terminals 1 and 2 must be connected. The operating frequency will always start with the most recent operating frequency/speed.	
				2	Current speed The variable frequency drive will start with the most recent current speed without a new start signal.	
				3	Fixed frequency 8 After a stop, the variable frequency drive will start with fixed frequency 8 (P2-08) without a new start command.	
				4	Minimum frequency (P1-02) After a stop, the variable frequency drive will start with the minimum frequency (P1-02) without a new start signal (terminal enable).	
				5	Most recently set speed After a stop, the variable frequency drive will start with the most recent current frequency (keypad setpoint value) without a new start signal (terminal enable).	
				6	Current speed If the variable frequency drive is configured for multiple speed reference values (typically manual/auto control or local/remote control) and a digital input is setting it to setpoint value = keypad, the motor will continue to be run with the most recent setpoint value (terminal enable)	
				7	Fixed frequency 8 After a stop, the variable frequency drive will start with fixed frequency 8 (P2-08) without a new start command (terminal enable).	
P6-03	603	✓	rw		Auto-reset delay	20
					Sets the delay time which will elapse between consecutive drive reset attempts when Auto Reset is enabled in P2-36.	
					1 - 60 s	

6.2.8 Motor

For optimum operating behavior, you should enter the specifications on the motor's rating plate here. They are the base values used to control the motor.

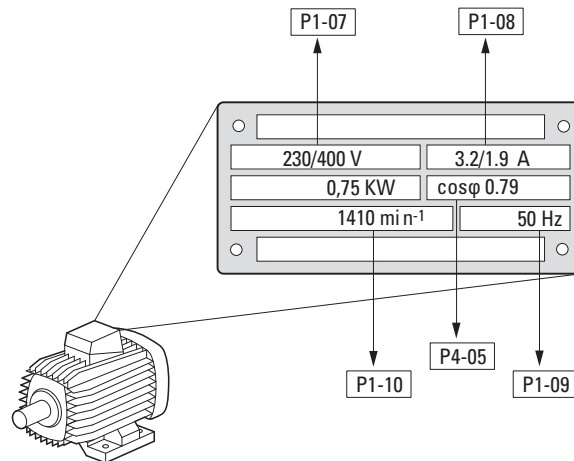

Figure 64: Motor parameters from ratings plate



The motor data is set to the rated operational data for the variable frequency drive and depends on the performance variables in default settings.

6.2.8.1 Circuit types for motor stator windings

When selecting the rating data, take the dependency of the type of switching on the strength of the feeding mains voltage into account:

- 230 V (P1-07) → delta circuit → P1-08 = 3.2 A
- 400 V (P1-07) → star-connected circuit → P1-08 = 1.9 A

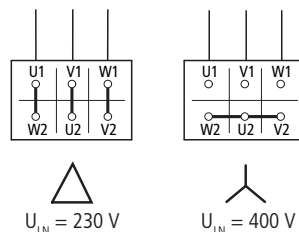

Figure 65: Circuits (delta, star)

Example

Single-phase connection of DC1-124D3... variable frequency drive to a mains voltage of 230 V. The motor's stator winding has a delta connection (motor rated current of 4 A as per rating plate in Figure 64). See¹⁾ in the default settings.

Required changes for electrically mapping the motor:
 P1-07 = 230, P1-08 = 4.0, P1-09 = 50

6 Parameters

6.2 Digital and analog inputs

PNU	ID	Access right		Value	Description	DS
		RUN	ro/rw			
P1-07	107	–	rw		Nominal voltage of the motor	230 ¹⁾
					Setting range: 0. 20 - 250/500 V (→ Motor ratings plate) Pay attention to the supply voltage and the type of circuit in the stator winding!	
					Note: This parameter value has a direct influence on the V/f characteristic curve (e.g. operation with 87 Hz characteristic curve). This must be especially taken into account in the case of values (P-07) that deviate from the variable frequency drive's rated operational data ($U_{LN} = 100\%$). This may cause the over-excitation of the motor and thus lead to an increased thermal load.	
P1-08	108	–	rw		Rated motor current	4.8 ¹⁾
					Setting range: $0.2 \times I_e - I_e$ [A] (→ Motor rating plate) I_e = Variable frequency drive's rated operational current	
P1-09	109	–	rw		Nominal frequency of the motor	50.0 ¹⁾
					Setting range: 25 - 500 Hz (→ Motor rating plate)	
					Note: This parameter value is also automatically applied as the cut-off frequency for the V/Hz characteristic curve.	
P1-10	110	✓	rw		Nominal speed of the motor	0
					0 - 30000 rpm (→ motor rating plate)	
					Note: This parameter can be optionally set to the motor's rated speed (revolutions per minute, rating plate). If it is set to the factory default setting of 0, all speed-related parameters will be shown in Hz; slip compensation for the motor will be disabled. Entering the value on the motor's rating plate will enable the slip compensation function, and the variable frequency drive's display will show the motor speed in the estimated rpm. All speed-related parameters (such as the minimum and maximum frequencies and the fixed frequencies) will also be shown in rpm.	
P4-05	405	✓	rw		Motor power factor ($\cos \varphi$)	0.78
					Note: When operating in Vector Speed or Vector Torque motor control modes, this parameter must be set to the motor name-plate power factor before autotuning (autotune).	
					0.5 - 0.99	

6.2.9 Fixed frequency setpoint values

Fixed frequency reference values have a higher priority than other frequency reference values. They can be accessed individually, or in binary code, via digital inputs DI1 to DI5.



The maximum permitted set value for a fixed frequency is limited by parameter P1-01 (maximum frequency). A fixed frequency value cannot go below a minimum limit frequency set at parameter P1-02. If a fixed frequency is lower than the minimum frequency (P1-02), the DA1 variable frequency drive will move to the minimum frequency.



The fixed frequency values can be changed during operation (RUN).

6.2.9.1 Fixed frequency

Four different fixed frequency reference values can be set in parameters P2-01 to P2-08 (FF1 to FF8).

In the unit's default configuration, fixed frequencies FF1 = 5 Hz and FF2 = 10 Hz can be accessed using digital input DI5 (control signal terminal 10), provided a voltage of +24 V is being applied at control signal terminal 3.

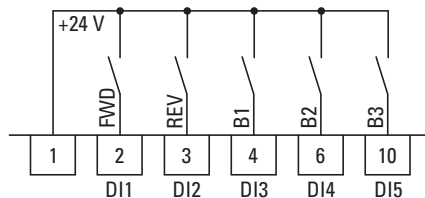

Figure 66: Example: fixed frequencies FF1 to FF8

6 Parameters

6.2 Digital and analog inputs

Example

P1-12 = 0; P1-13 = 12; P2-03 = 15; P2-04 = 20; P2-05 = 25; P2-06 = 30;
P2-07 = 40; P2-08 = 50

B1	B2	B3	Fixed frequency
0	0	0	FF1 (P2-01)
1	0	0	FF2 (P2-02)
0	1	0	FF3 (P2-03)
1	1	0	FF4 (P2-04)
0	0	1	FF5 (P2-05)
1	0	1	FF6 (P2-06)
0	1	1	FF7 (P2-07)
1	1	1	FF8 (P2-08)

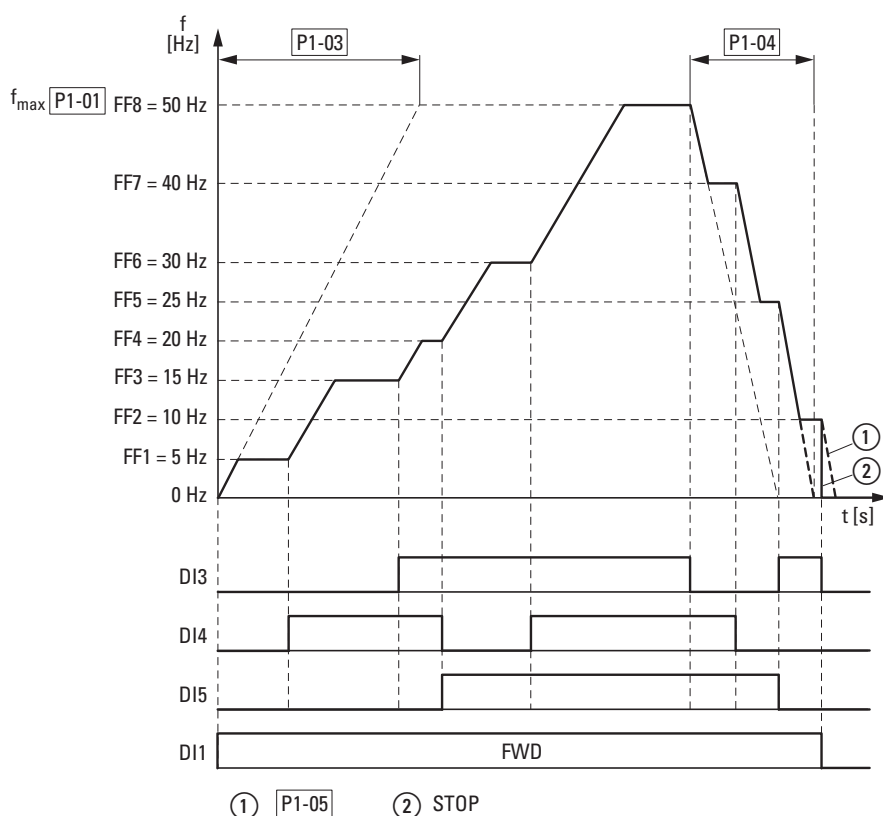

Figure 67: Example: Activation of the fixed frequencies with acceleration and deceleration ramps

The change between the individual fixed frequencies is done with the acceleration times and deceleration times set at P1-03 and P1-04 (→ Figure 67). When the FWD or REV enables are revoked, the output frequency is inhibited directly ② (coasting to halt). When P1-05 = 0, the drive performs a controlled deceleration ①.

6.2.10 V/f characteristic curve

The variable frequency drives of the DA1 series operate as a sinusoidal pulse width modulation (PWM) in the inverter. The IGBTs are switched with two control methods based on V/Hz control:

V/f (P1-10 = 0)

- Frequency control (Hz),
- Parallel connection of several motors,
- Large power difference ($P_{FU} \gg P_{Motor}$),
- Switching in the output.

V/f with slip compensation (P1-10 > 0)

- Speed control (min^{-1} , rpm) with slip compensation,
- Single operation (only the motor),
maximum one power rating smaller $P_{FU} > P_{Motor}$,
- High torque (requirement: exact motor data for the motor model).

The V/f-characteristic curve (voltage/frequency characteristic curve) designates a control process for the variable frequency drive, with which the motor voltage is controlled in a certain ratio to the frequency. If the voltage/frequency ratio is constant (linear characteristic curve), the magnetizing flux and the torque behavior of the connected motor is virtually constant.

In a standard application, the benchmark values for the V/f characteristic curve match the rated operational data of the connected motor (see the motor's rating plate):

- Output voltage P4-11 = Nominal motor voltage P1-07
- Cut-off frequency P4-10 = Rated motor frequency P1-09 =
Maximum frequency P1-01



The rating data of the V/f characteristic curve is assigned automatically and corresponds with the values of parameter P1-07 (nominal motor voltage) and P1-09 (rated motor frequency).

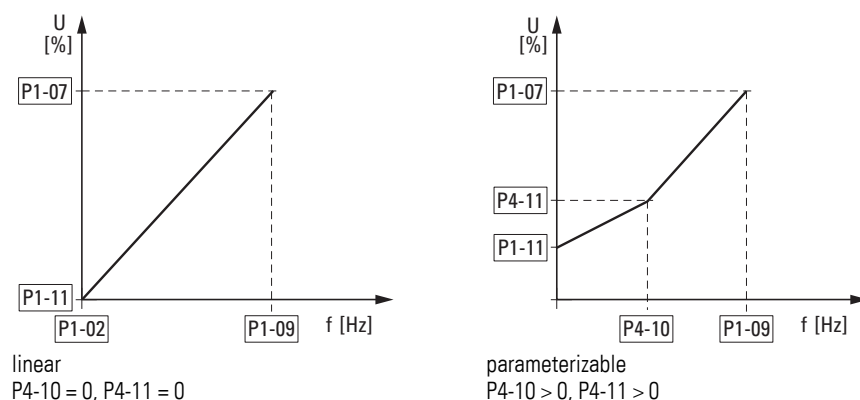

Figure 68: V/f-characteristic curve

6 Parameters

6.2 Digital and analog inputs

6.2.10.1 Speed behavior without slip compensation

On the constant three-phase AC supply, the three-phase asynchronous motor has a constant rotor speed (n_1 , P1-10, rating plate specifications) according to the number of pole pairs and mains frequency. The slip here represents the difference between the rotating field of the stator and that of the rotor. In static operation, the slip is constant.

Load changes ① at the motor shaft cause a larger slip (Δn) and thus a reduced rotor speed ②. In controlled operation (V/f characteristic curve), the variable frequency drive cannot compensate this load-related speed difference. The speed behavior of the motor corresponds to that of a motor in a constant AC supply system.

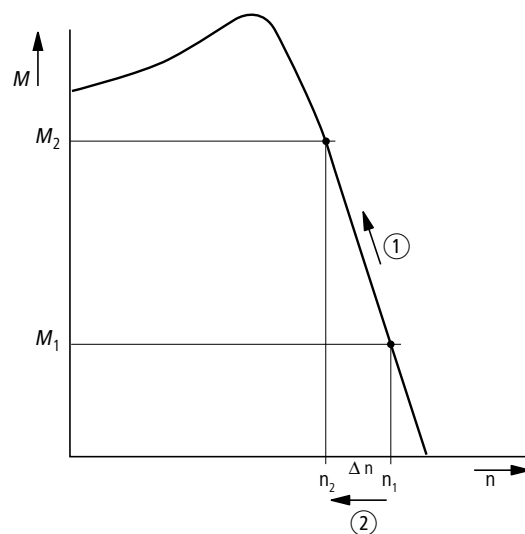

Figure 69: Speed behavior without slip compensation

6.2.10.2 Speed behavior with slip compensation

In the control mode (V/f with slip compensation, P1-10 > 0), the variable frequency drive can compensate for fluctuations caused by the load's characteristics. From the measured voltage and current values of the stator winding (u_1, i_1) the internal motor model calculates the required manipulated variables for the flux variable i_μ and the torque variable i_w . In the equivalent circuit diagram of the three-phase motor, the load-related slip is shown as the resistance R'_2/s . During no-load operation, this resistance approaches infinity, and approaches zero as the load increases.

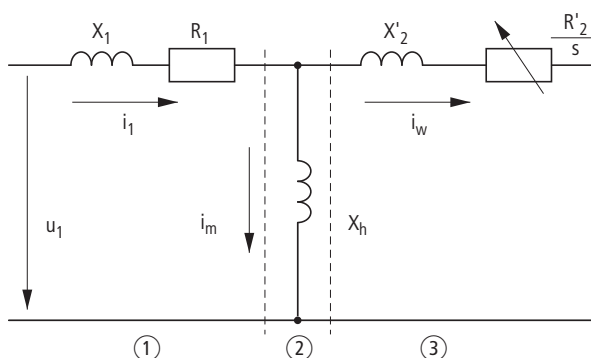

Figure 70: Equivalent circuit diagram for an asynchronous motor
 ① Stator winding
 ② Air gap
 ③ Transformed rotor winding

An exact calculation requires the precise rating specifications of the motor (P1-07, P1-08, P1-09). The speed control (P1-10 > 0) can then compensate the load-related slip deviations.

The simple illustration shows that, as the load torque increases (①), the resulting speed reduction is compensated by an increase in the output frequency (②) (→ Figure 71).

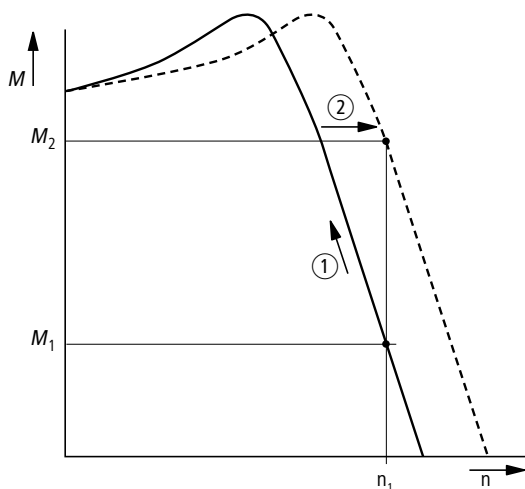

Figure 71: Speed behavior with slip compensation

6 Parameters

6.2 Digital and analog inputs

PNU	ID	Access right		Value	Description	DS
		RUN	ro/rw			
P1-02	102	✓	rw		<p>Minimum frequency / minimum speed</p> <p>P1-10 = 0 → 0 - P1-01 → Hz P1-10 > 0 → 0 - P1-01 → rpm</p> <p>The minimum output frequency / minimum speed limit in Hz or rpm. If P-10 > 0, the value entered/displayed will be shown in rpm.</p>	0
P1-07	107	–	rw		<p>Nominal voltage of the motor</p> <p>Setting range: 0. 20 - 250/500 V (→ Motor ratings plate) Pay attention to the supply voltage and the type of circuit in the stator winding!</p> <p>Note: This parameter value has a direct influence on the V/f characteristic curve (e.g. operation with 87 Hz characteristic curve). This must be especially taken into account in the case of values (P-07) that deviate from the variable frequency drive's rated operational data ($U_{LN} = 100\%$). This may cause the over-excitation of the motor and thus lead to an increased thermal load.</p>	230 ¹⁾
P1-09	109	–	rw		<p>Nominal frequency of the motor</p> <p>Setting range: 25 - 500 Hz (→ Motor rating plate)</p> <p>Note: This parameter value is also automatically applied as the cut-off frequency for the V/Hz characteristic curve.</p>	50.0 ¹⁾
P1-10	110	✓	rw		<p>Nominal speed of the motor</p> <p>0 - 30000 rpm (→ motor rating plate)</p> <p>Note: This parameter can be optionally set to the motor's rated speed (revolutions per minute, rating plate). If it is set to the factory default setting of 0, all speed-related parameters will be shown in Hz; slip compensation for the motor will be disabled. Entering the value on the motor's rating plate will enable the slip compensation function, and the variable frequency drive's display will show the motor speed in the estimated rpm. All speed-related parameters (such as the minimum and maximum frequencies and the fixed frequencies) will also be shown in rpm.</p>	0
P1-11	111	–	rw		<p>Output voltage at zero frequency</p> <p>0.00 - 20.0 %</p> <p>Voltage amplification is used in order to increase the motor voltage applied at low output frequencies so as to improve the torque at low speeds, as well as the starting torque.</p> <p>Note: A high start voltage enables a high torque at the start.</p> <p>Notice: A high torque at low speed causes a high thermal load on the motor. If temperatures are too high, the motor should be equipped with an external fan.</p>	3.0

6 Parameters

6.2 Digital and analog inputs

PNU	ID	Access right		Value	Description	DS
		RUN	ro/rw			
P4-10	410	–	rw		V/Hz characteristic curve modification voltage	0.0
					<p>When operating in V/f mode (P4-01 = 2), this parameter in conjunction with P4-11 sets a frequency point at which the voltage set in P4-11 is applied to the motor.</p> <p>Note: Care must be taken to avoid overheating and damaging the motor when using this function.</p> <p>0.00 - P1-09 %</p>	
P4-11	411	✓	rw		V/Hz characteristic curve modification frequency	0.0
					<p>Used in conjunction with P4-10.</p> <p>0.00 - P1-07 %</p>	

6 Parameters

6.2 Digital and analog inputs

6.2.11 Braking

Various braking functions can be configured:

- DC current braking,
- Generative braking (brake chopper),
- mechanical braking (actuation).

The brake functions allow you to reduce undesired coasting and long coasting times. Mechanical braking also ensures safe operating states.

6.2.11.1 DC current braking

With DC braking, the variable frequency drive supplies the three-phase stator winding of the three-phase motor with DC current. This generates a stationary magnetic field which induces a voltage in the rotor while the rotor is in motion. As the electrical resistance of the rotor is very low, even small induction can generate high rotor currents and thus a strong braking effect.

As the speed slows down, the frequency of the induced voltage and with it the inductive resistance drops. The resistive load becomes more effective and increases the braking effect.



DC current braking is not suitable for holding loads or for intermediate braking. Nor for intermediate braking.

NOTICE

DC current braking will cause increased motor heating.

6.2.11.2 Regenerative braking

If the rotor of an asynchronous motor is driven oversynchronously in the operating direction of the rotating field, it generates electric power via its stator windings. The motor then becomes a generator. In the variable frequency drive, this generative energy causes an increase in the DC link voltage.

Oversynchronous speeds occur, for example, when the output frequency in variable frequency drive operation is reduced with short deceleration times, the connected machine has a large flywheel mass or when the flowing medium in pumps and fans works against the speed reduction.

The increase in the DC link voltage is monitored by the DA1 variable frequency drive and always enables a braking torque of approx. 30 % of the rated motor torque. A higher braking torque can be achieved with a more powerful variable frequency drive. A brake chopper is integrated into DA1 variable frequency drives of size FS2 and larger. When used in conjunction with an external high-capacity resistor, this brake chopper makes it possible to achieve braking torques of up to 100 % of the rated motor torque.

The external braking resistance is connected via terminals DC+ and BR. It can be inserted into the variable frequency drive's heat sink.

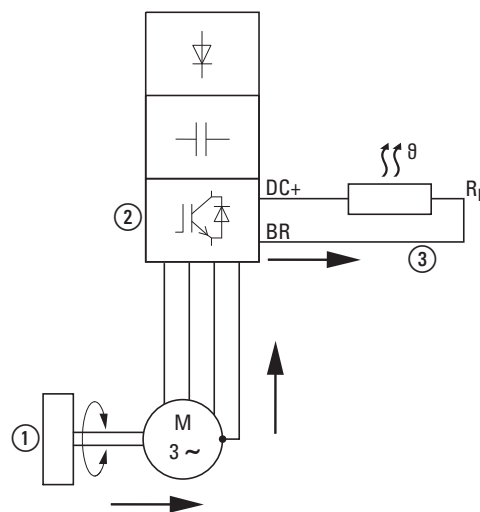

Figure 72: Regenerative braking with external braking resistance

- ① Machine flywheel mass
- ② Inverter with brake chopper (braking transistor)
- ③ Braking resistance (R_B) Energy flow (braking torque)

6 Parameters

6.2 Digital and analog inputs

6.2.11.3 Mechanical braking (hub applications)

An external mechanical brake can be actuated via the K2 relay output:

- K2 relay output: N/O contacts, control signal terminals 17 and 18, maximum 250 V AC / 6 A or 30 V DC / 5 A, P2-18 = 8

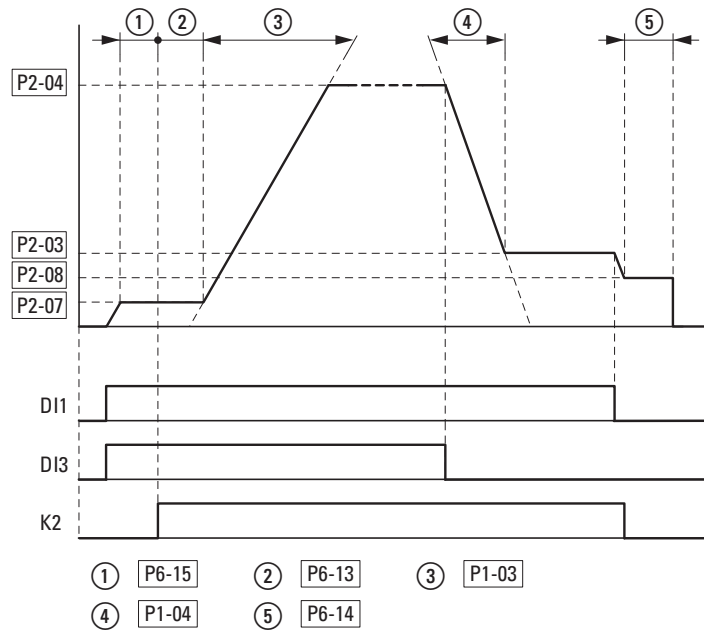

Figure 73: External brake actuation for hoisting applications

6 Parameters

6.2 Digital and analog inputs

PNU	ID	Access right		Value	Description	DS
		RUN	ro/rw			
P1-03	103	✓	rw		Acceleration time (acc1) 0.1 - 600 s	5
P1-04	104	✓	rw		Deceleration time (dec1) 0.1 - 600 s	5
P1-05		✓	rw		Stop Function	1
				0	Ramp, deceleration = Regenerative braking. Deceleration time with the value set under P1-04 (dec1). If the energy that is fed back by the motor during the dynamic braking is too high, the deceleration time has to be extended. In devices with an internal braking transistor, the excess energy can be dissipated with an external braking resistor (optional).	
				1	Free coasting = After the start enable (FWD/REV) is switched off or the STOP pushbutton is pressed (P1-12 and P1-13), the motor will coast uncontrolled.	
				2	Ramp, quick stop = regenerative braking. Deceleration time 2 with the value set under P2-25 (dec2). If the energy that is fed back by the motor during the dynamic braking is too high, the deceleration time has to be extended. In devices with an internal braking transistor, the excess energy can be dissipated with an external braking resistor (optional).	
P2-03	203	✓	rw		Fixed frequency FF3 / speed 3	0.0
					P1-10 = 0 → -P1-02 - P1-01 → Hz P1-10 > 0 → -P1-02 - P1-01 x 60 s → rpm (1/min)	
					0.00 Hz (P1-02) up to the maximum frequency value (P1-01). Activation via digital inputs depending on parameters P1-12 and P1-13.	
P2-04	204	✓	rw		Fixed frequency FF4 / speed 4	0.0
					P1-10 = 0 → -P1-02 - P1-01 → Hz P1-10 > 0 → -P1-02 - P1-01 x 60 s → rpm (1/min)	
					0.00 Hz (P1-02) up to the maximum frequency value (P1-01). Activation via digital inputs depending on parameters P1-12 and P1-13.	

6 Parameters

6.2 Digital and analog inputs

PNU	ID	Access right		Value	Description	DS
		RUN	ro/rw			
P2-07	207	✓	rw		<p>Fixed frequency FF7 / speed 7</p> <p>P1-10 = 0 → -P1-02 - P1-01 → Hz P1-10 > 0 → -P1-02 - P1-01 x 60 s → rpm (1/min)</p> <p>0.00 Hz (P1-02) up to the maximum frequency value (P1-01). Activation via digital inputs depending on parameters P1-12 and P1-13.</p>	0.0
P2-08	208	✓	rw		<p>Fixed frequency FF8 / speed 8</p> <p>P1-10 = 0 → -P1-02 - P1-01 → Hz P1-10 > 0 → -P1-02 - P1-01 x 60 s → rpm (1/min)</p> <p>0.00 Hz (P1-02) up to the maximum frequency value (P1-01). Activation via digital inputs depending on parameters P1-12 and P1-13.</p>	0.0
P6-13	613	✓	rw		<p>Motor brake opening time</p> <p>Sets the time for which the drive will hold at the Brake Release Speed (set in P2-07 - Preset Speed 7) to allow the motor brake to release.</p> <p>0.00 - 5.00 s</p>	0.2
P6-14	614	✓	rw		<p>Motor brake engagement delay</p> <p>Sets the time for which the drive will hold at the Brake Apply Speed (set in P2-08 - Preset Speed 8) to allow the motor brake to engage. For vertical hoist applications this value should not be set below the time required for the brake to engage (brake response time, as specified by the brake manufacturer). The minimum time is 0.1 s.</p> <p>0.00 - 5.00 s</p>	0.3
P6-15	615	✓	rw		<p>Minimum torque for brake opening</p> <p>Used to define the torque level (as a percentage of the rated motor torque) that must be reached before the signal for releasing the motor brake is issued. This ensures that the motor is connected and that sufficient torque is being generated in order to prevent the load from dropping when the mechanical brake is released. The function for the torque limit is not enabled in V/Hz mode.</p> <p>0.00 - 200 %</p>	8.0

Example
Stop function with two different deceleration times

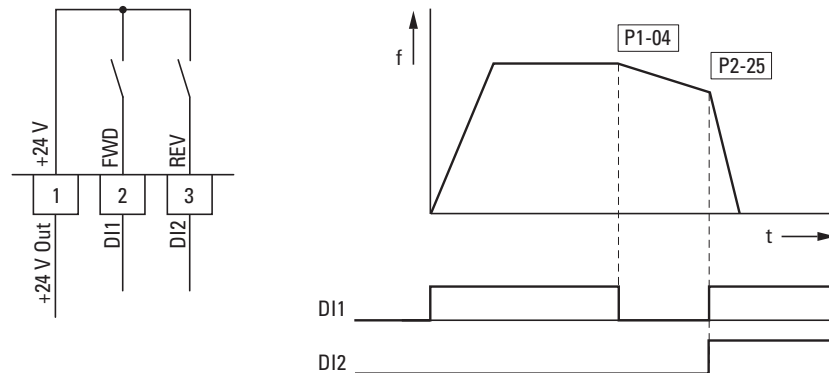

Figure 74: Stop function with two different deceleration times

The stop function can be activated with a deceleration time with $P1-05 = 0$. If the enable signal on digital input DI1 (FWD, control signal terminal 2) is switched off, the variable frequency drive's output frequency will be reduced as per the deceleration time (dec1) configured in P1-04.

The second deceleration time is set with parameter P2-25. In the default settings, the second deceleration time is activated via DI1 and DI2 (control signal terminals 2 and 3).

6 Parameters

6.3 Operational data indicator

6.3 Operational data indicator

When the specified supply voltage is applied (L1/L, L2/N, L3), the 7-segment LED display will be illuminated (Power ON); the display will show "Stop".

You can use arrow buttons ▲ and ▼ to select the operational data indicator you want (parameter number P0-...) in the "Monitor" (P0-...) menu. You can tell the display to stop alternating between the parameter number and the display value and only show the display value instead by pressing the OK button. If you want to access a different operational data indicator, press the OK button again. You can then make your selection using the ▲ and ▼ arrow buttons and confirm it with the OK button.



The values of the operating data display cannot be changed by hand (i.e. by value entry).

Example: Status displays

The status displays of the digital inputs and outputs are equivalent. They can be used to check whether an output control signal (e.g. from an external controller) activates the variable frequency drive's inputs (DI1 to DI4). This provides you with an easy way to check the wiring (wire breakage).

The following table shows a few examples.

Display value:

- 1 = activated = High
- 0 = not activated = Low

PNU	ID	Display value	Description
P0-03	11	00000	No digital input (DI1, DI2, DI3, DI4, DI5) is actuated
		10000	Control signal terminal 2 actuated (DI1)
		01000	Control signal terminal 3 actuated (DI2)
		00100	Control signal terminal 4 actuated (DI3)
		00010	Control signal terminal 6 actuated (DI4)
		00001	Control signal terminal 10 actuated (DI5)
		10101	Control signal terminals 2, 4 and 10 are actuated (DI2, DI3, DI5)

6.4 Setpoint input (REF)

REF: Setpoint value definition (Reference) via the operating unit







The frequency reference value settings configured via the keypad have the same effect as the function of an electronic motor potentiometer. The value set with the ▲ and ▼ buttons will be retained even after the supply voltage is switched off.



For control via the keypad, control signal terminal 1 must be connected to control signal terminal 2 in order to get an enable.

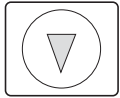
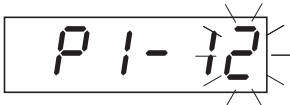
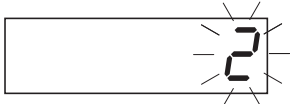
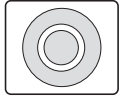

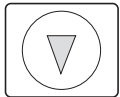

The following table shows a good example of specifying the frequency reference value via the operating unit.

Note: The information in the table may vary depending on the setting configured for P1-13.

Sequence	Commands	Indicator	Description
1	  	 	<p>Set parameter P1-12 to 1 or 2 in order to hand over control to the keypad.</p> <p>1: Operating unit (keypad FWD): one operating direction 2: Operating unit (keypad FWD/REV): both operating directions</p>
2	  	 	<p>Connect control signal terminal 1 to control signal terminal 2 in order to get a start enable.</p> <p>Press the STOP pushbutton in order to get to the setpoint input display automatically.</p> <p>Use the ▲ and ▼ arrow buttons to change the setpoint value.</p>

6 Parameters

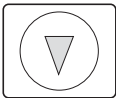
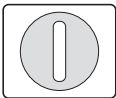
6.4 Setpoint input (REF)

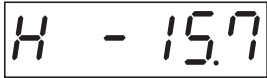
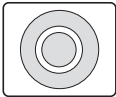
Sequence	Commands	Indicator	Description
3	  		<p>Press the START pushbutton to start the variable frequency drive. It will then run with the acceleration time set in P1-03 all the way to the setpoint value on the keypad.</p> <p>You can use the ▲ and ▼ arrow buttons to change the setpoint value in RUN mode.</p>
4	 FWD REV	 	<p>Pressing the START pushbutton again will change the operating direction (P1-12 = 2).</p> <p>Note: When the REV operating direction is in effect, the frequency will have a minus sign.</p> <p>Minus sign for REV operating direction</p>
5			<p>When the STOP pushbutton is pressed, the variable frequency drive will be stopped with the deceleration time configured in P1-04.</p>

7 Serial interface (Modbus RTU)

7.1 General

Modbus is a centrally polled bus system in which a so-called master (PLC) controls the entire data transfer on the bus. Internode communication between the individual modules (slaves) is not possible.

Every single data transfer operation is initiated by the master with a request. Only one request can be sent on the cable at a time.

Slaves are not able to initiate transfers, and are only able to respond to requests.

Two types of dialog are possible between master and slave:

- The master sends a request to a slave and waits for a response.
- The master sends a request to all slaves and does not wait for a response (broadcast).



More information on Modbus can be found under www.modbus.org.

7.1.1 Communication

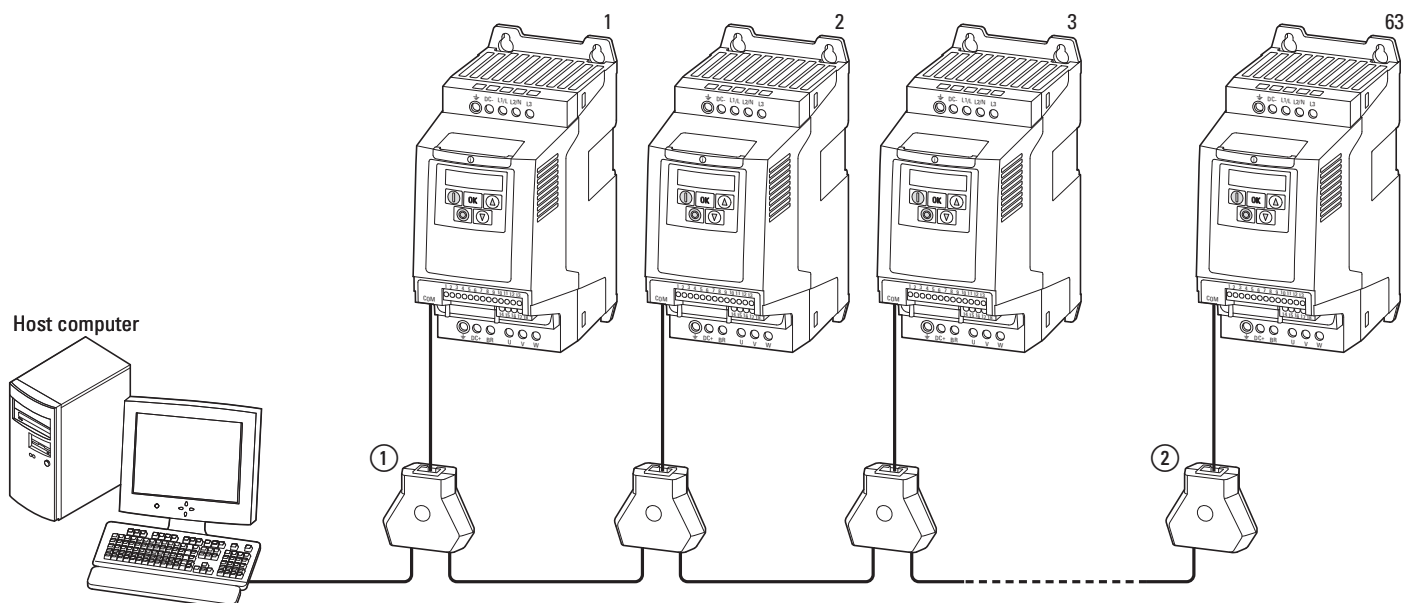

Figure 75: Modbus network with DA1 variable frequency drives

The figure shows a typical setup with a host computer (master) and any number (a maximum of 63 modules) of DA1 variable frequency drives (slaves). Each variable frequency drive has a unique address on the network. Addresses are assigned individually to each DA1 variable frequency drive with the P5-01 parameter and are independent of their physical connection (position) within the network.

7 Serial interface (Modbus RTU)

7.1 General

7.1.2 Serial interface

The electrical connection between the master and the slaves is established with RJ45 cables. If multiple slaves are being used, they are connected in parallel by using RJ45 cables and DX-SPL-RJ45-3SL splitters.

The DA1 variable frequency drive built-in RJ45 port supports the Modbus RTU protocol and therefore allows a direct network connection without an additional interface module. The network cable must be provided at each physical end (last station) with a bus termination resistor of 120 Ω in order to prevent signal reflections and the resulting transfer errors.

Splitter model DX-CBL-TERM includes the required resistor mentioned above.

	Pin	Meaning
	1	CAN -
	2	CAN +
	3	0 V
	4	OP bus (operation bus) / external keypad / PC connection -
	5	OP bus (operation bus) / external keypad / PC connection +
	6	24 V DC power supply
	7	RS485- Modbus RTU
	8	RS485+ Modbus RTU

Figure 76: RJ45 socket wiring

7.2 Modbus parameters

The following table 15 shows the Modbus parameters in the DA1 variable frequency drive.

RUN Indicates the access right during operation (FWD or REV)

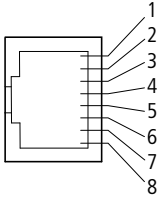
- = No parameter change possible,

✓ = Parameter change possible.

ro/rw Indicates the access right via the field bus

ro = Read only possible,

rw = Read and write possible.

Table 15: Modbus parameters

PNU	ID	Access right		Designation	Value range	DS
		RUN	ro/rw			
P5-01	501	✓	rw	Variable frequency drive slave address	0 - 63	1
P5-03	503	✓	rw	Modbus RTU Baud rate	0 = 9.6 kBit/s 1 = 19.2 kBit/s 2 = 38.4 kBit/s 3 = 57.6 kBit/s 4 = 115.2 kBit/s	4
P5-04	504	✓	rw	Modbus RTU data format – Parity type	n-1 = No parity, 1 stop bit n-2 = No parity, 2 stop bits 0-1 = Odd parity, 1 stop bit E-1 = Even parity, 1 stop bit	n-1
P5-05	505	✓	rw	Timeout – Communications dropout	0.00 - 5.00 s	2
P5-06	506	✓	rw	Response in the event of a communications dropout	0 = Switch off and free coasting 1 = Deceleration ramp, switch off 2 = Deceleration ramp, no switch off 3 = Fixed frequency 8	0
P5-07	507	✓	rw	Ramp via field bus	0 = Deactivated 1 = activated	0
P1-12		-	rw	Control level	0 = Control signal terminals (I/O) 1 = Keypad (KEYPAD FWD) 2 = Keypad (KEYPAD FWD/REV) 3 = PID control 4 = Field bus (Modbus RTU, PROFIBUS etc.) 5 = Slave mode 6 = Field bus (CANopen)	0

7.3 Operating mode Modbus RTU

Operating mode Modbus RTU (Remote Terminal Unit) transfers the data in binary format (faster data rate) and determines the transfer format for the data request and the data response. Each message byte that is sent contains two hexadecimal characters (0 - 9, A - F).

The data transfer between a master (PLC) and the DA1 variable frequency drive is carried out according to the following sequence:

- Master request: the master sends a Modbus frame to the variable frequency drive.
- Slave response: the variable frequency drive sends a Modbus frame as a response to the master.

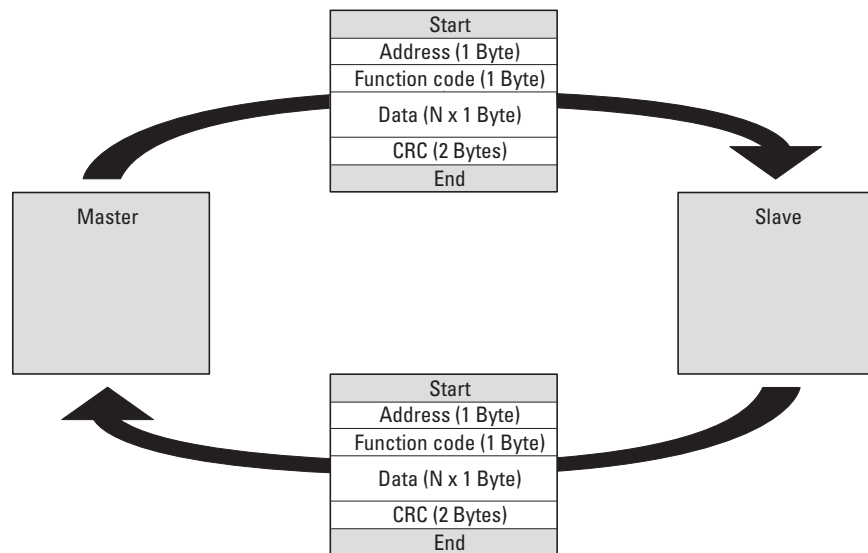

Figure 77: Data exchange between master and slave



The variable frequency drive (slave) only sends a response if it has received a request from the master beforehand.

7.3.1 Structure of the master request

7.3.1.1 Address

- The slave address (1 to 63) of the recipient variable frequency drive is entered in the parameter P5-01. Only the variable frequency drive with this address can respond to the request.
- Address 0 is used as a so-called Broadcast (message to all bus users) from the master. In this mode, individual modules cannot be addressed and data cannot be output from the slaves.

7.3.1.2 Function code

The function code defines the type of message. The following actions can be performed in the case of DA1 variable frequency drives:

Function code [hex]	Designation	Description
03	Read Holding Registers	Reading of the holding registers (process data, parameters, configuration) in the slave. A master request enables up to 11 registers to be read.
06	Write Single Register	Writing of a holding register in the slave. With a general telegram (Broadcast) the appropriate holding registers are written in all slaves. The register is read back for comparison.

7.3.1.3 Data

The length of the data block (data: N x 1 bytes) depends on the function code. The function code is made up of two hexadecimal values and has a range of 00 to FF. The data block contains additional information for the slave that will enable the latter to perform the operation specified by the master in the function code (this information may specify the parameters that need to be processed, for example).

7.3.1.4 Cyclic redundancy check (CRC)

Frames in the Modbus RTU operating mode include a cyclic redundancy check (CRC). The CRC field is made up of two bytes that contain a binary 16-bit value. The CRC check is always run independently of the parity check for the individual characters of the telegram. The CRC result is appended to the frame by the master. While receiving the frame, the slave performs a new calculation and compares the calculated value to the actual value in the CRC field. If both values are not identical, an error is set.

7 Serial interface (Modbus RTU)

7.3 Operating mode Modbus RTU

7.3.2 Structure of the slave response

7.3.2.1 Required transfer time

- The time between receiving a request from the master and the response of the variable frequency drive is at least 3.5 characters (rest time).
- Once the master has received a response from the variable frequency drive, it must wait for at least the rest time before it can send a new request.

7.3.2.2 Normal slave response

- If the master request contains a write register function (function code 06), the variable frequency drive immediately returns the request as a response.
- If the master request contains a read register function (function code 03), the variable frequency drive returns the read data with the slave address and the function code as a response.

7.3.2.3 No slave response

In the following cases, the variable frequency drive ignores the request and does not send a reply:

- On receiving a broadcast request.
- If the request contains a transmission error.
- If the slave address in the request does not match the variable frequency drive's address.
- With a CRC or parity error.
- If the time interval between the messages is less than 3.5 characters.



The master must be programmed to repeat the request if it does not receive a response within a specified time.

7.3.3 Modbus: Register mapping

Register mapping makes it possible to process, in DA1 variable frequency drives, the contents in the following table via Modbus RTU.

Group	Register	Assignment of the ID numbers
Mode parameter	101 - 813	List of parameters
Input process data	1 - 5	→ Section 7.3.3.1, "Input process data", page177
Output process data	6 - 43	→ Section 7.3.3.2, "Output process data", page178
Internal registers	51 - 80	→ Section, "Internal registers", page180

→ The interface driver in certain controllers (e.g. PLCs) may have an offset of +1 for Modbus RTU communications

→ The decimal point is not taken into account when processing values!
For example, if the motor current (Register 8) shown on the DA1 variable frequency drive's display is 0.3 A, it will be transmitted as 003_{dez} via Modbus.

7.3.3.1 Input process data

The input process data is used to control the DA1 variable frequency drive.

ID	Designation	Scaling Factor	Unit
1	Field bus control word	–	Binary code
2	Field bus speed reference value	0.1	Hz
3	Torque control reference	0.1	%
4	Modbus ramp time	0.01	s
5	IDL speed reference	–	–

Control word (Register 1)

These bits are used to control the DA1 variable frequency drive. You can modify the content as required for your own specific application and then send it as a control word to the variable frequency drive.

Bit	Description	
	Value = 0	Value = 1
0	Stop	Operation
1	Clockwise rotating field (FWD)	Anticlockwise rotating field (REV)
2	No action	Reset error
3	No action	Free coasting
4	Not used	

7 Serial interface (Modbus RTU)

7.3 Operating mode Modbus RTU

Bit	Description	
	Value = 0	Value = 1
5	No action	Quick stop (ramp 2)
6	No action	Fixed frequency FF1
7	No action	Overwrite setpoint value with 0
8	Not used	Control via field bus
9	Not used	
10	Not used	
11	Not used	
12	Not used	
13	Not used	
14	Not used	
15	Not used	

Speed reference value (Register 2)

The permissible values fall within a range of 0 to P1-01 (max. frequency). This value is scaled with a factor of 0.1 in the application.

15	14	13	12	11	10	9	8	7	6	5	4	3	2	1	0
MSB															LSB

7.3.3.2 Output process data

The output process data is used to monitor the variable frequency drive.

ID	Designation	Scaling Factor	Unit/Format
6	Status and fault word	–	Binary code
7	Field bus actual speed	0.1	Hz
8	Motor current	0.1	A
9	Torque	0.1	%
10	Output power	0.01	kW
11	DI status	–	Binary code
12	Type	–	WORD
13	Power	1	kW/HP
14	Voltage level	1	V
15	Software version, control part	–	WORD
16	Software version, power section	–	WORD
17	Drive ID	–	WORD
18	Bandwidth of channel 1	–	–
19	Bandwidth of channel 2	–	–
20	Value AI1	0.1	%

7 Serial interface (Modbus RTU)

7.3 Operating mode Modbus RTU

ID	Designation	Scaling Factor	Unit/Format
21	Value AI2	0.1	%
22	Reference input speed	1	RPM
23	DC link voltage	1	V
24	Variable frequency drive temperature	1	°C
25	Inverters, serial number 4	–	–
26	Inverters, serial number 3	–	–
27	Inverters, serial number 2	–	–
28	Inverters, serial number 1	–	–
29	Status of relay output	–	–
30	kWh meter	0.1	kWh
31	MWh counter	0.1	MWh
32	kWh meter	0.1	kWh
33	MWh counter	0.1	MWh
34	Operating time in hours	–	–
35	Operating time in minutes/seconds	–	–
36	Operating time since last enable, in hours	–	–
37	Operating time since last enable, in minutes/seconds	–	–
38	reserved	–	–
39	Room temperature	–	–
40	IDL speed reference	–	–
41	Torque reference value	–	–
42	Digital output reference value	–	–
43	PO-80	–	–

7 Serial interface (Modbus RTU)

7.3 Operating mode Modbus RTU

Internal registers

51	User register 1	–	–
52	User register 2	–	–
53	User register 3	–	–
54	User register 4	–	–
55	User register 5	–	–
56	User register 6	–	–
57	User register 7	–	–
58	User register 8	–	–
59	User register 9	–	–
60	User register 10	–	–
61	User register 11	–	–
62	User register 12	–	–
63	User register 13	–	–
64	User register 14	–	–
65	User register 15	–	–
66	Analog output 1	–	–
67	Analog output 2	–	–
68	reserved	–	–
69	reserved	–	–
70	Relay output 1	–	–
71	Relay output 2	–	–
72	Relay output 3	–	–
73	Relay output 4	–	–
74	Relay output 5	–	–
75	User scaling user interface	–	–
76	Number of decimals on the user interface	–	–
77	User speed reference value	–	–
78	User torque reference value	–	–
79	User ramp time	–	–
80	Bandwidth indexes 1, 2	–	–

7.3.3.3 Status and fault word (Register 6)

Device status and error message information is provided in the status word (bit 0 to bit 7) and error word (bit 8 to bit 15).

15	14	13	12	11	10	9	8	7	6	5	4	3	2	1	0
MSB															LSB
Fault word								Status word							

Status word

Bit	Description	
	Value = 0	Value = 1
0	Drive not ready	Ready for operation (READY)
1	Stop	Running operation message (RUN)
2	Clockwise rotating field (FWD)	Anticlockwise rotating field (REV)
3	no error	Fault detected (FAULT)
4	Acceleration ramp	Frequency actual value equals setpoint value definition
5	–	Zero speed
6	Speed control deactivated	Speed control activated
7	Not used	

Fault word

Failure code [hex]	Value shown on display	Meaning
00	<i>no-Fault</i>	Stop, ready for operation
01	<i>01-b</i>	Overcurrent brake chopper
02	<i>0-br</i>	Braking resistance overload
03	<i>0-l</i>	<ul style="list-style-type: none"> Overcurrent at variable frequency drive output Motor overload Excessively high temperature on variable frequency drive (heat sink)
04	<i>1-t-ERP</i>	Motor, thermal overload
05	<i>5RFE - 1</i>	Short-circuit at safety circuit input
06	<i>0 Uo1 t5</i>	Overvoltage (DC link)
07	<i>0 Uo1 t5</i>	Undervoltage (DC link)
08	<i>0-t</i>	Overtemperature (heat sink)
09	<i>0-t</i>	Undertemperature (heat sink)
0A	<i>P-dEF</i>	Default settings, parameters have been loaded
0C	<i>E-tr iP</i>	External error message
0D	<i>5C-0b5</i>	Error, Optibus
0E	<i>FLt-dc</i>	Excessively large voltage waves in DC link
0F	<i>P-L055</i>	Phase failure (mains side)
0F	<i>h 0-l</i>	Overcurrent at variable frequency drive output

7 Serial interface (Modbus RTU)

7.3 Operating mode Modbus RTU

Failure code [hex]	Value shown on display	Meaning
10	<i>th-FI t</i>	Thermistor fault, internal (heat sink)
11	<i>dRE R-F</i>	EEPROM checksum fault
12	<i>4-2DF</i>	Analog input: <ul style="list-style-type: none"> • Out-of-range value • Wire breakage (4 mA monitoring)
13	<i>dRE R- E</i>	Error in internal memory
14	<i>H-dEF</i>	User-definable factory parameters have been loaded
15	<i>F-Ptc</i>	Excessively high temperature, motor PTC
16	<i>FAN-F</i>	Fault, internal fan
17	<i>D-hERt</i>	Excessively high ambient temperature
18	<i>D-tor 9</i>	Maximum torque limit exceeded
19	<i>H-tor 9</i>	Output torque too low
1 A	<i>Dut-F</i>	Fault at variable frequency drive output
1D	<i>SARE-2</i>	Short-circuit at safety circuit input
1D	<i>Enc-01</i>	Encoder, communication lost
1F	<i>Enc-02</i>	Encoder, speed error
20	<i>Enc-03</i>	Encoder, wrong PPRs set
21	<i>Enc-04</i>	Encoder, channel A fault
22	<i>Enc-05</i>	Encoder, channel B fault
23	<i>Enc-06</i>	Encoder, channel A and B fault
24	<i>Enc-07</i>	Encoder, RS485 data channel error
25	<i>Enc-08</i>	Encoder, IO communication lost
26	<i>Enc-09</i>	Encoder, incorrect type
27	<i>Enc-10</i>	Encoder
28	<i>REt-01</i>	Motor stator resistance fluctuating between phases
29	<i>REt-02</i>	The motor's stator resistance is too high
2B	<i>REt-03</i>	Motor inductance too low
C2	<i>REt-04</i>	Motor inductance too high
2C	<i>REt-05</i>	The motor parameters do not match the motor
32	<i>SC-F01</i>	Fault: Modbus communication loss error
33	<i>SC-F02</i>	Fault: CANopen communication loss error
34	<i>SC-F03</i>	Communications with field bus module disconnected
35	<i>SC-F04</i>	Loss of I/O card communications
3C	<i>DF-01</i>	Connection to add-on card lost
3D	<i>DF-02</i>	Add-on card in unknown state
46	<i>PLC-01</i>	Unsupported PLC function
47	<i>PLC-02</i>	PLC program too big
48	<i>PLC-03</i>	Division by 0
49	<i>PLC-04</i>	Lower limit is higher than upper limit

7.3.3.4 Actual speed (Register 7)

The variable frequency drive's actual speed falls within a value range of 0 to P1-01 (max. frequency). This value is scaled with a factor of 0.1 in the application.

15	14	13	12	11	10	9	8	7	6	5	4	3	2	1	0
MSB															LSB

Current (ID 8)

The current is specified with one decimal place.

Example: 34 \triangleq 3.4 A.

Torque (ID 9)

The motor torque is specified with one decimal place.

Example: 1000 \triangleq 100.0 %

Output power (ID 10)

The output power is specified in kW with one decimal place.

Example: 53 \triangleq 5.3 kW

Digital inputs (ID 11)

This value indicates the digital inputs' state. The lowest bit indicates the state of DI 1.

Type (ID 12)

The value indicates the variable frequency drive's part no.

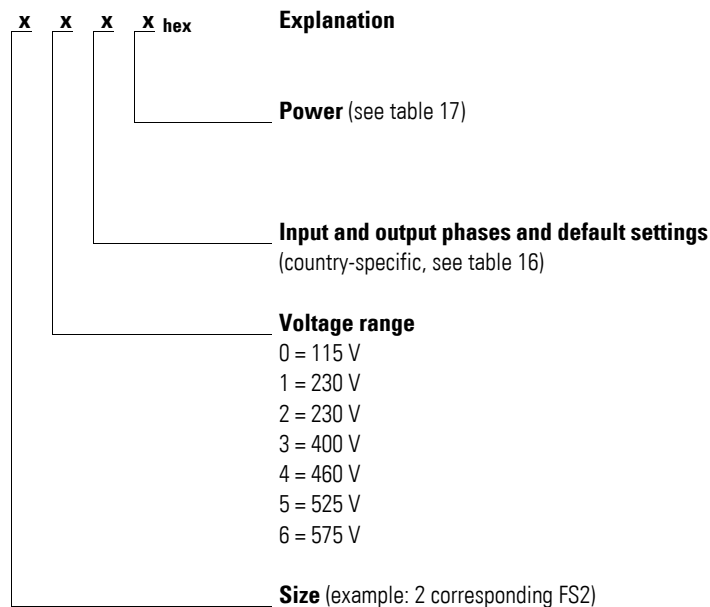

7 Serial interface (Modbus RTU)

7.3 Operating mode Modbus RTU

Table 16: Input and output phases

Value	Country-specific default settings	Number of phases on mains side	Number of phases on motor side
0	kW	3	3
1	HP	3	3
2	kW	3	1
3	HP	3	1
4	kW	1	3
5	HP	1	3
6	kW	1	1
7	HP	1	1

Table 17: Assigned ratings

		0	1	2	3	4	5	6	7
FS2	kW	0.75	1.5	2.2	0.75	1.5	2.2	4	–
	HP	1	2	3	1	2	3	5	–
FS3	kW	3	4	5.5	5.5	7.5	11	–	–
	HP	4	5	7.5	7.5	10	15	–	–
FS4	kW	7.5	11	15	18.5	22	–	–	–
	HP	10	15	20	25	30	–	–	–
FS5	kW	15	18.5	22	30	37	45	–	–
	HP	20	25	30	40	50	60	–	–
FS6	kW	22	30	37	45	45	55	75	90
	HP	30	40	50	60	60	75	12	15
FS7	kW	55	75	90	110	132	160	–	–
	HP	75	100	125	175	200	250	–	–

Rated outputs (ID 13)

Indicates the device's output with two decimal places. The unit is defined in register 12.

Example: 75 \triangleq 0.75

Voltage (ID 14)

Specifies the device's specified input voltage.

Example: 230 \triangleq 230 V

Control part software version (ID 15)

Specifies the software version of the control section with two decimal places.

Power section software version (ID 16)

Specifies the software version of the power section with two decimal places.

Variable frequency drive recognition (ID 17)

The device's unique serial number.

Analog input signal (ID 20, ID 21)

Indicates the current value of the analog input with one decimal place.

Speed reference input (ID 22)

Indicates the difference between the setpoint and the process value.

7.3.4 Explanation of function code

7.3.4.1 Function code 03_{hex}: Reading of holding registers

This function reads the content of a number of consecutive holding registers (specified register addresses).

Example:

Reading the status and fault word (ID 6) of the DA1 variable frequency drive with slave address 1.

Master request: 01 03 0005 0001 140B_{hex}

hex	Name
01	Station address
03	Function code (reading of holding registers)
0005	5 _{dez} : The ID is 6, since the motor controller has an offset of +1.
0001	Total number of requested registers
C940	CRC

Slave response: 01 03 02 0000 B844_{hex}

hex	Name
01	Station address
03	Function code (reading of holding registers)
02	Number of consecutive data bytes (1 register = 2 byte)
0000	Content (2 byte) for register 6: 0
B844	CRC

7 Serial interface (Modbus RTU)
 7.3 Operating mode Modbus RTU

7.3.4.2 Function code 06_{hex}: Writing a holding register

This function writes data to a holding register.

Example

Writing of the control word (ID 1) of a DA1 variable frequency drive with the slave address 1.

Master request: 01 06 0000 0001 480A_{hex}

hex	Name
01	Station address
06	Function code (writing a holding register)
0000	0: The ID of the register for the writing operation is 1, since the master controller has an offset of +1.
0001	Content (2 byte) for register 0000 0000 0000 001 _{bin} → RUN
480A	CRC

Slave response: 01 06 0000 0001 480_{hex}

The slave response is a copy of the master request if it is a normal response.

hex	Name
01	Station address
06	Function code (here: writing a holding register)
0000	1: The ID of the register for the writing operation is 1, since the master controller has an offset of +1.
0001	Content (2 byte) for register 0000 0000 0000 001 _{bin} → RUN
480A	CRC



Function code 06_{hex} can be used for a broadcast.

8 CANopen

A thorough knowledge of the CANopen field bus and the programming of a CANopen master is required in this chapter. In addition, readers must be familiar with how to use the DA1 variable frequency drive.

References

[1] CANopen – Application Layer and Communication Profile
CiA Draft Standard DS301, Version 4.02, February, 13, 2002

8.1 Data Types

CANopen has specifications for its own data types. The data types listed in the following table are used for the DA1 variable frequency drive's CANopen protocol handler.

Table 18: CANopen data types

Name	Description	Range	
		Minimum	Maximum
UNSIGNED8	8-bit unsigned integer (b7 to b0)	0	255
UNSIGNED16	16-bit unsigned integer (b15 to b0)	0	65535
UNSIGNED32	32-bit unsigned integer (b31 to b0)	0	4294967295
INTEGER8	8-bit signed integer (b7 to b0)	-128	127
INTEGER16	16-bit signed integer (b15 to b0)	-32768	32767
INTEGER32	32-bit signed integer (b31 to b0)	-2147483648	2147483647
RECORD	Data structure with fixed number of any types	-	-

The following abbreviations are used throughout this chapter:

CAL	CAN Application Layer
CAL	CAN Application Layer
CAN	Controller Area Network
COB ID	Communication Object Identifier
CONST	Constant variable (read access only)
DEC	Decimal (base-10 numeral system)
EDS	Electronic Data Sheets
EMCY	Emergency Object
HEX	Hexadecimal (base-16 numeral system)
ID	Identifier
LSS	Layer Setting Service
NMT	Network Management
PC	Personal Computer
PDO	Process Data Object

8 CANopen

8.2 System overview

CAL	CAN Application Layer
ro	Read Only (read access only)
ROM	Read Only Memory
RTR	Remote Transmit Request
rw	Read/Write (read/write access)
Rx	Receive
SDO	Service Data Object
Tx	Transmit

8.2 System overview

The DA1 variable frequency drive's CANopen slaves are integrated into a CANopen fieldbus system.

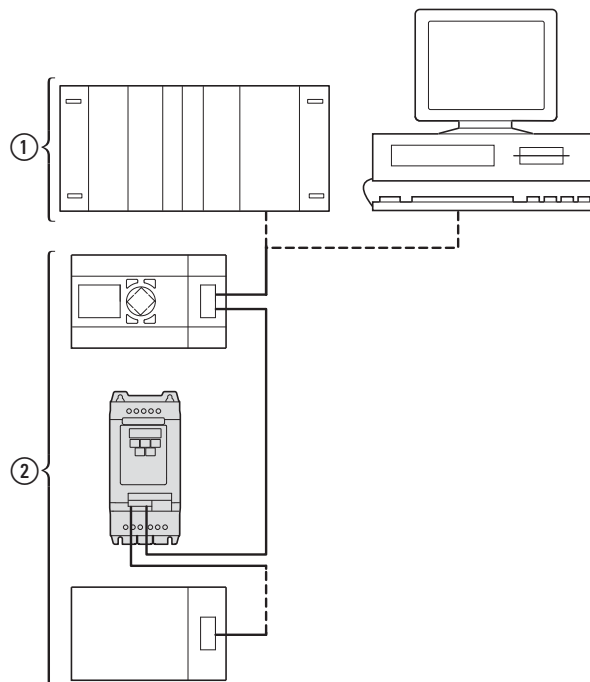

Figure 78: Integrating a DA1 variable frequency drive into a CANopen network

- ① Master area, PLC (e.g.: XC100, XC200) or PC with CANopen card
- ② Slave area: Variable frequency drives with CANopen interface

The RJ45 connector enables DA1 series variable frequency drives to connect to a CANopen communication network. The CiA DS-301 CANopen communication profile documents the "How" of communications.

The CANopen communications protocol draws a distinction between process data objects (PDOs) and service data objects (SDOs). The variable frequency drive is controlled with fast, cyclic process data (PDOs). The process data channel can be used not only to specify the speed setpoint, but also to trigger various drive functions, such as enables, operating directions, and resets. At the same time, it can also be used to read actual values, such as the actual speed, current, and device status, from the variable frequency drive. As a general rule, the variable frequency drive's parameters are configured using SDOs. The parameter data channel makes it possible to store all application-related drive parameters in the higher-level automation system and transfer them to the variable frequency drive if necessary. All of the variable frequency drive's parameters can be transferred with CANopen by using the appropriate SDO/PDO selection.

Table 19: Technical Data

Size	Value
Communication profile	DS-301 V4.02
Bus addresses	1 - 63
Data transfer rate	125 kBit/s - 1 MBit/s
Total distance (depending on the baud rate / the repeater)	<ul style="list-style-type: none"> • up to 500 m at 125 kBit/s • up to 300 m at 1 MBit/s
Transmission medium	Screened, twisted-pair cable
Bus termination resistor	120 Ω, suitable for separate mounting
Number of SDOs	1 server, 0 clients
Number of PDOs	2 Rx-PDO 2 Tx-PDO Note: Only one will be enabled in the default settings.
PDO mapping	variable
Terminal types	Plug-in RJ45 socket

8 CANopen

8.2 System overview

8.2.1 Bus termination resistors

The first and last module of a CANopen network must be terminated by means of a 120 Ω bus termination resistor. This device is interconnected between the CAN_H and CAN_L terminals.

Splitter DX-CBL-TERM1 ② can be used for this purpose.

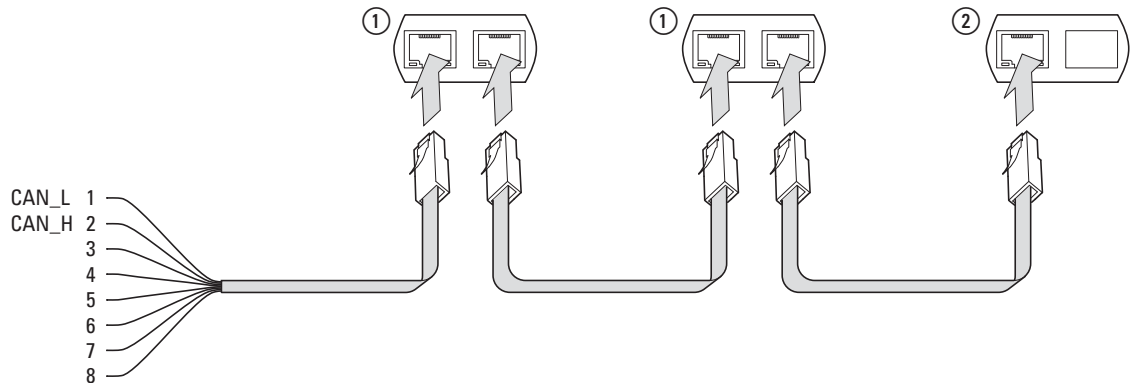

Figure 79: Bus termination resistors

8.2.2 Baud rate

The baud rate is set in parameter P5-02. It must be set to the same value for all communication modules on the CANopen bus.

8.2.3 Set CANopen station address

Every CANopen module needs a unique address (node ID) within the CANopen structure. All node IDs must be unique within the entire bus structure. A maximum of 127 addresses (1 to 127) can be assigned within a CANopen structure. Parameter P5-01 is used to configure the CANopen address in DA1 variable frequency drives.

8.2.4 Parameters that need to be configured

PNU	ID	Access right		Designation	Value range	DS	Value that must be set
		RUN	ro/rw				
P1-12	112	–	rw	Control level	0 = Control terminals (I/O) 1 = Keypad (KEYPAD FWD) 2 = Keypad (KEYPAD FWD / REV) 3 = PID control 4 = Field bus system (Modbus RTU, PROFIBUS etc.) 5 = Slave mode 6 = Field bus (CANopen)	0	6
P5-01	501	✓	rw	Variable frequency drive slave address	0 - 63	1	1 - 63
P5-02	502	✓	rw	CANopen baud rate	0 = 125 kBit/s 1 = 250 kBit/s 2 = 500 kBit/s 3 = 1000 kBit/s	500	0 - 3

8.3 Object list

8.3.1 EDS file

The DC1 variable frequency drive can be integrated into a CANopen structure with the help of a standardized EDS (Electronic Data Sheet) file. EDS describes the functionality of a CANopen device in a machine-readable format. EDS files list all objects, the supported baud rates, the manufacturer, and other information as well.

The latest version of the EDS file is included in the CD-ROM enclosed with every variable frequency drive.

It can also be downloaded from Eaton's website at:

<http://www.eaton.com/moeller> → **Support**

The object dictionary contains all the objects corresponding to a CANopen module. Objects are used to map a device's functionality/parameters.

They are accessed with SDOs or PDOs. As per the corresponding specification, the object dictionary is subdivided into the following ranges:

Table 20: Object dictionary ranges

Range	Description
0000hex - 1FFFhex	Communication-specific objects (from DS-301)
2000hex - 5FFFhex	Manufacturer-specific objects (the variable frequency drive's parameters)

The object dictionary for the DA1 variable frequency drive contains the entries described below.

8 CANopen

8.3 Object list

8.3.2 Communication-specific objects

A detailed description of the communication parameters is provided in the CiA specification [1] Section 9.6.3.

Objects 1000hex, 1001hex, and 1018hex are required for all CANopen devices; all other objects are optional. The DA1 variable frequency drive supports the objects listed in the following tables.

Index [hex]	Subindex [hex]	Objectname	Data type	Access right	DS	Meaning
1000	00	Device Type	UNSIGNED32	ro	0	Variable frequency drive – CANopen device
1001	00	Error Register	UNSIGNED8	ro	–	Error indication: 00 _{hex} = No error
1002	00	Manufacturer Status Register	UNSIGNED16	ro	00	Emergency object fault log
1005	00	COB-ID SYNC Message	UNSIGNED32	rw	80	COB-ID of the SYNC object, device consumes the SYNC message
1008	00	Manufacturer Device Name	STRING	ro	DA1	The variable frequency drive's device name: DA1
1009	00	Manufacturer Hardware Version	STRING	ro	1.11 (Example)	Hardware version of the module
100A	00	Manufacturer Software Version	STRING	ro	1.00 (Example)	Software version of the module
100C	00	Guard Time	UNSIGNED16	rw	0000 _{hex} Resolution in 1 ms	Monitoring time in milliseconds
100D	00	Life Time Factor	UNSIGNED8	rw	00 _{hex}	Multiplier for the Guard Time, the result is equivalent to the maximum interval between the transfer of two Guarding message frames
1014	00	COB-ID EMCY Message	UNSIGNED32	rw	00000080 + Node ID	CAN identifier of the emergency message
1018	00	Identity Object	UNSIGNED8	ro	04	General device information
	01	Vendor ID	UNSIGNED32	ro	000001C7	Manufacturer: Eaton Industries GmbH
	02	Product Code	UNSIGNED32	ro	0	Product Number
	03	Revision Number	UNSIGNED32	ro	1.01 (Example)	Version
	04	Serial Number	UNSIGNED32	ro	00000001 (Example)	Serial number

8.3.3 Server SDO Parameter

Index [hex]	Subindex [hex]	Objectname	Data type	Access right	DS	Meaning
1200	00	Number of Entries	UNSIGNED8	ro	02	Number of inputs
	01	COB-ID Client → Server (rx)	UNSIGNED32	ro	00000600 + Node ID	COB-ID of the RxSDO. The ID is derived from the Predefined Connection Set.
	02	COB-ID Server → Client (tx)	UNSIGNED32	ro	00000580 + Node ID	COB-ID of the TxSDO. The ID is derived from the Predefined Connection Set.

The DA1 variable frequency drive supports two receive PDOs (receive PDO communication parameters 1400_{hex} and 1401_{hex}).

Objects 1600_{hex} and 1601_{hex} contain the mapping parameters for the Rx PDOs.

Index [hex]	Subindex [hex]	Objectname	Data type	Access right	DS	Meaning
1400 1401		1st Receive PDO Parameter 2nd Receive PDO Parameter	RECORD	ro	03	Number of valid subindexes
	00	Number of Entries	UNSIGNED8	ro	02	Maximum number of entries
	01	PDO COB-ID	UNSIGNED32	rw	400002 00 40000300 + Node ID	COB-ID of 1st Rx PDO COB-ID of 2nd Rx PDO
	02	Transmission Type	UNSIGNED8	rw	254	PDO transmission type: asynchronous
1600	00	Number of Mapped Application Objects	UNSIGNED8	rw	04	Highest subindex used
	01	1st Mapping Object	UNSIGNED32	rw	20000010	
	02	2nd Mapping Object	UNSIGNED32	rw	20000010	
	03	3rd Mapping Object	UNSIGNED32	rw	20020010	
	04	4th Mapping Object	UNSIGNED32	rw	20020010	
1601	00	Number of Mapped Application Objects	UNSIGNED8	rw	4	Highest subindex used
	01	1st Mapping Object	UNSIGNED32	rw	00060010	
	02	2nd Mapping Object	UNSIGNED32	rw	00060010	
	03	3rd Mapping Object	UNSIGNED32	rw	00060010	
	04	4th Mapping Object	UNSIGNED32	rw	00060010	

8 CANopen

8.3 Object list

DA1 variable frequency drive supports two transmit PDOs (transmit PDO communication parameters 1800_{hex} and 1801_{hex}).

Objects 1A00_{hex} and 1A01_{hex} contain the mapping parameters for the Tx PDOs.

Index [hex]	Subindex [hex]	Objectname	Data type	Access right	DS	Meaning
1800 1801		1st Transmit PDO Parameter 2nd Transmit PDO Parameter	RECORD	ro	04	Number of valid subindexes
	00	Number of Entries	UNSIGNED8	ro	03	Number of entries
	01	PDO COB-ID	UNSIGNED32	rw	40000180 40000280 + Node ID	COB-ID of 1st Tx PDO COB-ID of 2nd Tx PDO
	02	Transmission Type	UNSIGNED8	rw	254	PDO transmission type: asynchronous
	03	Inhibit time (100 µs)	UNSIGNED16	ro	0	
1A00		1st Transmit PDO Mapping	RECORD			applies for Tx PDO 1
	00	Number of Mapped Application Objects	UNSIGNED8	rw	4	Highest subindex used
	01	1st Mapping Object	UNSIGNED32	rw	200A0010	
	02	2nd Mapping Object	UNSIGNED32	rw	200B0010	
	03	3rd Mapping Object	UNSIGNED32	rw	200D0010	
	04	4th Mapping Object	UNSIGNED32	rw	200E0010	
1A01		2nd Transmit PDO Mapping	RECORD			applies for Tx PDO 2
	00	Number of Mapped Application Objects	UNSIGNED8	rw	4	Highest subindex used
	01	1st Mapping Object	UNSIGNED32	rw	200F0010	
	02	2nd Mapping Object	UNSIGNED32	rw	20100010	
	03	3rd Mapping Object	UNSIGNED32	rw	20110010	
	04	4th Mapping Object	UNSIGNED32	rw	200C0010	

8.3.4 Manufacturer-specific objects

In addition to communication-specific objects, manufacturer-specific objects are also defined in the object dictionary. These objects fall within the range between index 2000_{hex} and index 23E9_{hex} in the DA1 variable frequency drive's object dictionary.

Table 21: Manufacturer-specific objects

Index [hex]	Property Name	Data type	Access right	Description
2000	Control command register	UNSIGNED16	rw	Control word
2001	Speed reference	INTEGER16	rw	Frequency reference value
2002	Torque reference	Integer16	rw	Torque control reference
2003	User ramp reference	UNSIGNED16	rw	User ramp time
2004	Speed ref (internal)	INTEGER16	rw	IDL speed reference
200A	Drive status register	UNSIGNED16	ro	Status word
C200	Motor speed Hz	UNSIGNED16	ro	Actual value in Hertz (Hz)
200C	Motor speed (internal)	UNSIGNED16	ro	IDL actual speed
200D	Motor current	UNSIGNED16	ro	Motor current
200E	Motor torque	INTEGER16	ro	Torque
200F	Motor power	UNSIGNED16	ro	Power in kW
2010	Drive temperature	INTEGER16	ro	Variable frequency drive temperature
2011	DC bus value	UNSIGNED16	ro	DC link voltage
2012	Digital input status	UNSIGNED16	ro	State of digital inputs
2013	Analog input 1 (%)	UNSIGNED16	ro	Analog input 1 in %
2014	Analog input 2 (%)	UNSIGNED16	ro	Analog input 2 in %
2015	Analog input 1	UNSIGNED16	ro	Analog input 1
2016	Analog input 2	UNSIGNED16	ro	Analog input 2
2017	Relay output 1	UNSIGNED16	ro	Relay output 1
2018	Relay output 2	UNSIGNED16	ro	Relay output 2
2019	Relay output 3	UNSIGNED16	ro	Relay output 3
201A	Relay output 4	UNSIGNED16	ro	Relay output 4
C201	Relay output 5	UNSIGNED16	ro	Relay output 5
201C	Scope channel 1	UNSIGNED16	ro	Scope channel 1
201D	Scope channel 2	UNSIGNED16	ro	Scope channel 2
201E	Scope channel 3	UNSIGNED16	ro	Scope channel 3
201F	Scope channel 4	UNSIGNED16	ro	Scope channel 4
2020	User data 1	UNSIGNED16	rw	User data 1
2021	User data 2	UNSIGNED16	rw	User data 2
2022	User data 3	UNSIGNED16	rw	User data 3
2023	User data 4	UNSIGNED16	rw	User data 4
2024	User data 5	UNSIGNED16	rw	User data 5

8 CANopen

8.3 Object list

Index [hex]	Property Name	Data type	Access right	Description
2025	User data 6	UNSIGNED16	rw	User data 6
2026	User data 7	UNSIGNED16	rw	User data 7
2027	User data 8	UNSIGNED16	rw	User data 8
2028	User data 9	UNSIGNED16	rw	User data 9
2029	User data 10	UNSIGNED16	rw	User data 10
202A	User data 11	UNSIGNED16	rw	User data 11
C202	User data 12	UNSIGNED16	rw	User data 12
202C	User data 13	UNSIGNED16	rw	User data 13
202D	User data 14	UNSIGNED16	rw	User data 14
202E	User data 15	UNSIGNED16	rw	User data 15
202F	User analog output 1	UNSIGNED16	rw	User, analog output 1
2030	User analog output 2	UNSIGNED16	rw	User, analog output 2
2033	User relay output 1	UNSIGNED16	rw	User, relay output 1
2034	User relay output 2	UNSIGNED16	rw	User, relay output 2
2035	User relay output 3	UNSIGNED16	rw	User, relay output 3
2036	User relay output 4	UNSIGNED16	rw	User, relay output 4
2037	User relay output 5	UNSIGNED16	rw	User, relay output 5
203A	Kilowatt hours	UNSIGNED16	ro	Operating time in kW
C203	Megawatt hours	UNSIGNED16	ro	Operating time in MW
203C	KWh meter	UNSIGNED16	ro	Total operating time in kW
203D	MWh meter	UNSIGNED16	ro	Total operating time in MW
203E	Total run hours	UNSIGNED16	ro	Operating time in hours
203F	Total run minute/second	UNSIGNED16	ro	Operating time in minutes/seconds
2040	Current run hours	UNSIGNED16	ro	Current operating time in hours
2041	Current run minute/second	UNSIGNED16	ro	Current operating time in minutes/seconds
2042	Time to next service	UNSIGNED16	ro	Time to next service
2043	Room temperaure	UNSIGNED16	ro	Room temperature
2044	Speed controller reference	UNSIGNED16	ro	
2045	Torque controller reference	UNSIGNED16	ro	
2046	Digital pot speed reference	UNSIGNED16	ro	
2065	P1-01		rw	Parameter of P1 group
To	...			
2072	P1-14			
20C9	P2-01		rw	Parameter of P2 group
To	...			
20F0	P2-40			

Index [hex]	Property Name	Data type	Access right	Description
212D	P3-01		rw	Parameter of P3 group
To	...			
213A	P3-14			
2191	P4-01		rw	Parameter of P4 group
To	...			
219C	P4-12			
21F5	P5-01		rw	Parameter of P5 group
To	...			
2202	P5-14			
2259	P6-01		rw	Parameter of P6 group
To	...			
2276	P6-30			
22BD	P7-01		rw	Parameter of P7 group
To	...			
22CD	P7-17			
2321	P8-01		rw	Parameter of P8 group
To	...			
232F	P8-15			
2385	P9-01		rw	Parameter of P9 group
To	...			
23AD	P9-41			
23E8	Scope index 12		rw	
23E9	Scope index 34		rw	

8 CANopen

8.3 Object list

8.3.5 Control word (Index 2000_{hex})

The “control word” object is used to control the variable frequency drive. It contains manufacturer-specific commands.

Name	Description	
	Value = 0	Value = 1
0	Stop	Operation
1	Clockwise rotating field (FWD)	Anticlockwise rotating field (REV)
2	No action	Fault Reset
3	No action	Free coasting
4	Not used	
5	No action	Quick stop with ramp 2
6	No action	Fixed frequency FF1
7	No action	Overwrite setpoint value with 0
8	Not used	
9	Not used	
10	Not used	
11	Not used	
12	Not used	
13	Not used	
14	Not used	
15	Not used	

Frequency reference value (Index 2001_{hex})

The frequency reference value is specified in hertz with a single decimal place.

Example: 258_{dez} \triangleq 25.8 Hz

Torque control reference (Index 2002_{hex})

The torque control reference is specified as a percentage with one decimal place.

Example: 127_{dez} \triangleq 12.7 %

User ramp time (Index 2003_{hex})

The user ramp time is specified in seconds with two decimal places.

Status word (Index 200A_{hex})

Information regarding the variable frequency drive's device status (Bit 0 to Bit 7) and error messages (Bit 8 to Bit 15) is specified in the status word.

15	14	13	12	11	10	9	8	7	6	5	4	3	2	1	0
MSB															LSB
Error messages								Status word							

Name	Description	
	Value = 0	Value = 1
0	Drive not ready	READY
1	Stop	Running operation message (RUN)
2	Clockwise rotating field (FWD)	Anticlockwise rotating field (REV)
3	No error	Fault detected (FAULT)
4	Acceleration ramp	Frequency actual value equals setpoint value definition
5	–	Zero speed
6	Speed control deactivated	Speed control activated
7	Not used	

8 CANopen

8.4 Error messages

8.4 Error messages

Table 22: Error messages

Failure code [hex]	Failure code in the display	Designation
00	<i>no-F iE</i>	Stop, ready for operation
01	<i>01 -b</i>	Braking chopper overcurrent
02	<i>0 -br</i>	Braking resistance overload
03	<i>0 -l</i>	<ul style="list-style-type: none"> Overcurrent at variable frequency drive output Motor overload Overtemperature at inverter (heat sink)
04	<i>lE -t rP</i>	Motor, thermal overload
05	<i>S RFE - 1</i>	Short-circuit at safety circuit input
06	<i>0 Uol tS</i>	Overvoltage (DC link)
07	<i>H Uol tS</i>	Undervoltage (DC link)
08	<i>0 -t</i>	Overtemperature (heat sink)
09	<i>H -t</i>	Undertemperature (heat sink)
0A	<i>P -dEF</i>	Default settings, parameters have been loaded
C0	<i>E -t r iP</i>	external error message
0C	<i>5C -0b5</i>	Error, Optibus
0D	<i>FLt -dc</i>	Excessively large voltage waves in DC link
0E	<i>P -L055</i>	Phase failure (mains side)
0F	<i>h 0 -l</i>	Overcurrent at variable frequency drive output
10	<i>t h -Fl t</i>	Thermistor fault, internal (heat sink)
11	<i>dRtR -F</i>	EEPROM checksum fault
12	<i>4 -20 F</i>	Analog input: <ul style="list-style-type: none"> Out-of-range value Wire breakage (4 mA monitoring)
13	<i>dRtR -E</i>	Error in internal memory
14	<i>H -dEF</i>	User-definable factory parameters have been loaded
15	<i>F -P t c</i>	Excessively high temperature, motor PTC
16	<i>F R n -F</i>	Internal fan fault
17	<i>0 -hERt</i>	Excessively high ambient temperature
18	<i>0 -t or 9</i>	Maximum torque limit exceeded
19	<i>H -t or 9</i>	Output torque too low
1 A	<i>0 u t -F</i>	Fault at variable frequency drive output
1D	<i>S RFE - 2</i>	Short-circuit at safety circuit input
1D	<i>E n c - 0 1</i>	Encoder, communication lost
1F	<i>E n c - 0 2</i>	Encoder, speed error
20	<i>E n c - 0 3</i>	Encoder, wrong PPRs set

Failure code [hex]	Failure code in the display	Designation
21	<i>ENC-04</i>	Encoder, error in channel A
22	<i>ENC-05</i>	Encoder, error in channel B
23	<i>ENC-06</i>	Encoder, error in channels A and B
24	<i>ENC-07</i>	Encoder, RS485 data channel error
25	<i>ENC-08</i>	Encoder, I/O communications loss
26	<i>ENC-09</i>	Encoder, incorrect type
27	<i>ENC-10</i>	Encoder, KTY fault
28	<i>REF-01</i>	Motor stator resistance fluctuating between phases
29	<i>REF-02</i>	The motor's stator resistance is too high
2B	<i>REF-03</i>	Motor inductance too low
C2	<i>REF-04</i>	Motor inductance too high
2C	<i>REF-05</i>	The motor parameters do not match the motor
32	<i>SC-F01</i>	Fault, Modbus communication loss error
33	<i>SC-F02</i>	Fault, CANopen communication loss error
34	<i>SC-F03</i>	Communications with field bus module disconnected
35	<i>SC-F04</i>	I/O card communications loss
3C	<i>DF-01</i>	Connection to add-on card lost
3D	<i>DF-02</i>	Add-on card in unknown state
46	<i>PLC-01</i>	Unsupported PLC function
47	<i>PLC-02</i>	PLC program too big
48	<i>PLC-03</i>	Division by 0
49	<i>PLC-04</i>	Lower limit is higher than upper limit
4A	<i>PLC-05</i>	Error in PLC program

Frequency actual value (Index 2001_{hex})

The frequency actual value is specified in hertz with a single decimal place.

Example: 125_{dez} \triangleq 12.5 Hz

Current (Index 200D_{hex})

The current is specified with one decimal place.

Example: 34 \triangleq 3.4 A

Torque (Index 200E_{hex})

The motor torque is specified as a percentage.

Example: 4096_{dez} \triangleq 0 %

Output power (Index 200F_{hex})

The output power is specified in kW with two decimal places.

Example: 553 \triangleq 5.53 kW

8 CANopen

8.4 Error messages

9 Appendix

9.1 Special technical data

The following tables show the technical data of the variable frequency drive DA1 in the individual power classes with the allocated motor output.



The motor output allocation is based on the rated operational current.



The motor output designates the respective active power output to the drive shaft of a normal, four pole, internally or externally ventilated alternating current asynchronous motor with 1.500 rpm at 50 Hz or 1.800 rpm at 60 Hz.

9 Appendix

9.1 Special technical data

9.1.1 DA1-12 device series

Size	Symbol	Unit	4D3	7D0	011		
Rated operational current	I_e	A	4.3	7.0	10.5		
Overload current for 60 s every 600 s at 50 °C	I_L	A	6.45	10.5	15.75		
Apparent power at rated operation ¹⁾	230 V	S	kVA	1.71	2.79	4.18	
	240 V		kVA	1.79	2.91	4.36	
Assigned motor power	230 V	P	kW	0.75	1.5	2.2	
			HP	1	2	3	
Power side (primary side):							
Number of phases			single-phase or two-phase				
Rated operating voltage			200 - 10 % - 240 + 10 %, 50/60 Hz (180 - 264 V \pm 0 %, 48 - 62 Hz \pm 0 %)				
Input current			I_{LN}	A	8.5	13.9	19.5
Minimum braking resistance			R_B	Ω	100	50	35
Pulse frequency			f_{PWM}	kHz	16 (adjustable 4 – 32)		
Efficiency			η		0.96	0.96	0.96
Size					FS2	FS2	FS2

9.1.2 DA1-32 device series

Size	Symbol	Unit	4D3	7D0	011	018	024	024		
Rated operational current	I_e	A	4.3	7.0	10.5	18	24	24		
Overload current for 60 s every 600 s at 50 °C	I_L	A	6.45	10.5	15.75	27	36	36		
Apparent power at rated operation	S	230 V	kVA	1.71	2.79	4.18	7.17	9.56	9.56	
		240 V	kVA	1.79	2.91	4.36	7.48	9.98	9.98	
Assigned motor rating	P	230 V	kW	0.75	1.5	2.2	4.0	5.5	5.5	
			HP	1	2	3	5	7.5	7.5	
Power side (primary side):										
Number of phases			three-phase							
Rated operating voltage			200 V - 10 % - 240 V +10 %, 50/60 Hz (180 - 264 V ±0 %, 48 - 62 Hz ±0 %)							
Input current			I_{LN}	A	4.5	7.3	11	18.8	24.8	24.8
Minimum braking resistance			R_B	Ω	100	50	35	20	20	20
Pulse frequency										
Default settings			f_{PWM}	kHz	16					
minimum T. - maximum T.			f_{PWM}	kHz	4 - 32	4 - 32	4 - 32	4 - 32	4 - 16	4 - 16
Efficiency			η		0.96	0.96	0.96	0.96	0.96	0.97
Size					FS2	FS2	FS2	FS3	FS3	FS4

Size	Symbol	Unit	039	046	061	072	090	110		
Rated operational current	I_e	A	39	46	61	72	90	110		
Overload current for 60 s every 600 s at 50 °C	I_L	A	58.5	69	91.5	108	135	165		
Apparent power at rated operation	S	230 V	kVA	15.5	18.3	24.3	28.7	35.9	43.8	
		240 V	kVA	16.2	19.1	25.4	29.9	37.4	45.7	
Assigned motor rating	P	230 V	kW	7.5	11	15	18.5	22	30	
			HP	10	15	20	25	30	40	
Power side (primary side):										
Number of phases			three-phase							
Rated operating voltage			200 V - 10 % - 240 V +10 %, 50/60 Hz (180 - 264 V ±0 %, 48 - 62 Hz ±0 %)							
Input current			I_{LN}	A	40	47.1	62.4	74.1	92.3	112.7
Minimum braking resistance			R_B	Ω	22	22	12	12	6	6
Pulse frequency										
Default settings			f_{PWM}	kHz	8	8	8	8	8	4
minimum T. - maximum T.			f_{PWM}	kHz	4 - 24	4 - 24	4 - 24	4 - 24	4 - 24	4 - 16
Efficiency			η		0.97	0.97	0.97	0.97	0.97	0.97
Size					FS4	FS4	FS5	FS5	FS6	FS6

9 Appendix

9.1 Special technical data

9.1.3 DA1-32 device series

Size	Symbol	Unit	150	180	202	248		
Rated operational current	I_e	A	150	180	202	248		
Overload current for 60 s every 600 s at 50 °C	I_L	A	225	270	303	372		
Apparent power at rated operation	230 V	S	kVA	59.8	71.7	80.5	98.8	
		240 V	kVA	62.4	74.8	84	103.1	
Assigned motor rating	230 V	P	kW	37	45	55	75	
			HP	50	60	75	100	
Power side (primary side):								
Number of phases			three-phase					
Rated operating voltage			200 V - 10 % - 240 V +10 %, 50/60 Hz (180 - 264 V \pm 0 %, 48 - 62 Hz \pm 0 %)					
Input current			I_{LN}	A	153.5	183.8	206.2	252.8
Minimum braking resistance			R_B	Ω	6	6	6	6
Pulse frequency								
Default settings			f_{PWM}	kHz	4	4	4	4
minimum T. - maximum T.			f_{PWM}	kHz	4 - 12	4 - 8	4 - 16	4 - 12
Efficiency			η		0.97	0.97	0.98	0.98
Size					FS6	FS6	FS7	FS7

9.1.4 DA1-34 device series

Size	Symbol	Unit	2D2	4D1	5D8	9D5	014	018	024		
Rated operational current	I_e	A	2.2	4.1	5.8	9.5	14	18	24		
Overload current for 60 s every 600 s at 50 °C	I_L	A	3.3	6.15	8.7	14.25	21	27	36		
Apparent power at rated operation	S	400 V	1.52	2.84	4.02	6.58	9.7	12.5	16.6		
		480 V	1.83	3.41	4.8	7.9	11.6	15	20		
Assigned motor rating	P	400 V	0.75	1.5	2.2	4.0	5.5	7.5	11		
		460 V	1	2	3	5	7.5	10	15		
Power side (primary side):											
Number of phases			three-phase								
Rated operating voltage			380 V - 10 % - 480 V +10 %, 50/60 Hz (342 - 528 V ±0 %, 48 - 62 Hz ±0 %)								
Input current			I_{LN}	A	2.4	4.3	6.1	9.8	14.6	18.1	24.7
Minimum braking resistance			R_B	Ω	400	200	150	100	75	50	40
Pulse frequency											
Default settings			f_{PWM}	kHz	8	8	8	8	8	8	8
minimum T. - maximum T.			f_{PWM}	kHz	4 - 32	4 - 32	4 - 32	4 - 32	4 - 24	4 - 24	4 - 16
Efficiency			η		0.97	0.97	0.97	0.97	0.97	0.97	0.97
Size					FS2	FS2	FS2	FS2	FS3	FS3	FS3

Size	Symbol	Unit	024	030	039	046	061	072	090		
Rated operational current	I_e	A	24	30	39	46	61	72	90		
Overload current for 60 s every 600 s at 50 °C	I_L	A	36	45	58.5	69	91.5	108	135		
Apparent power at rated operation	S	400 V	16.6	20.8	27	31.9	42.3	49.9	62.4		
		480 V	20	24.9	32.4	38.2	50.7	59.9	74.8		
Assigned motor rating	P	400 V	11	15	18.5	22	30	37	45		
		460 V	15	20	25	30	40	50	60		
Power side (primary side):											
Number of phases			three-phase								
Rated operating voltage			380 V - 10 % - 480 V +10 %, 50/60 Hz (342 - 528 V ±0 %, 48 - 62 Hz ±0 %)								
Input current			I_{LN}	A	24.8	30.8	40	47.1	62.8	73.8	92.2
Minimum braking resistance			R_B	Ω	40	22	22	22	12	12	6
Pulse frequency											
Default settings			f_{PWM}	kHz	8	8	8	8	8	8	4
minimum T. - maximum T.			f_{PWM}	kHz	4 - 16	4 - 24	4 - 24	4 - 24	4 - 24	4 - 24	4 - 16
Efficiency			η		0.97	0.97	0.97	0.97	0.97	0.97	0.97
Size					FS4	FS2	FS2	FS2	FS2	FS3	FS3

9 Appendix

9.1 Special technical data

Size	Symbol	Unit	110	150	180	202	240	302
Rated operational current	I_e	A	110	150	180	202	240	302
Overload current for 60 s every 600 s at 50 °C	I_L	A	165	225	270	303	360	453
Apparent power at rated operation	S	400 V	76.2	104	125	140	166	209
		480 V	91.5	125	150	168	200	251
Assigned motor rating	P	400 V	55	75	90	110	132	160
		460 V	75	120	150	175	200	250
Power side (primary side):								
Number of phases			three-phase					
Rated operating voltage	U_{LN}	V	380 V - 10 % - 480 V +10 %, 50/60 Hz (342 - 528 V \pm 0 %, 48 - 62 Hz \pm 0 %)					
Input current	I_{LN}	A	112.5	153.2	183.7	205.9	244.5	307.8
Minimum braking resistance	R_B	Ω	6	6	6	6	6	6
Pulse frequency								
Default settings	f_{PWM}	kHz	4	4	4	4	4	4
minimum T. - maximum T.	f_{PWM}	kHz	4 - 16	4 - 12	4 - 8	4 - 16	4 - 12	4 - 8
Efficiency	η		0.97	0.97	0.98	0.98	0.98	0.98
Size			FS6	FS6	FS6	FS7	FS7	FS7

9.2 Dimensions and frame size

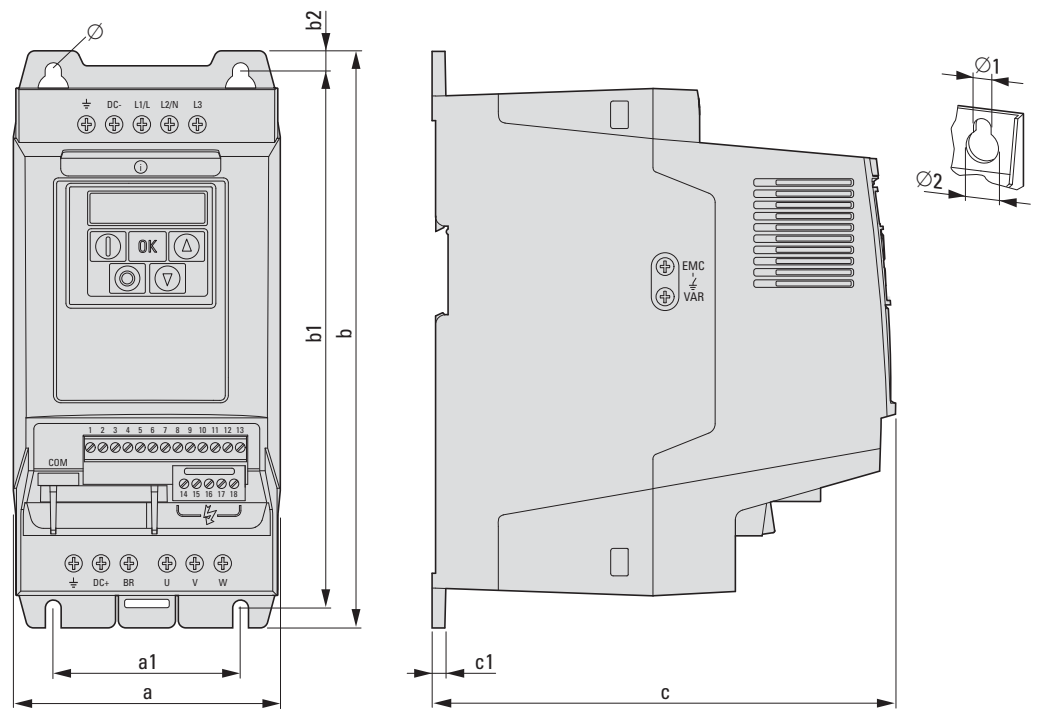

Figure 80: Sizes FS2 and FS3

9 Appendix

9.2 Dimensions and frame size

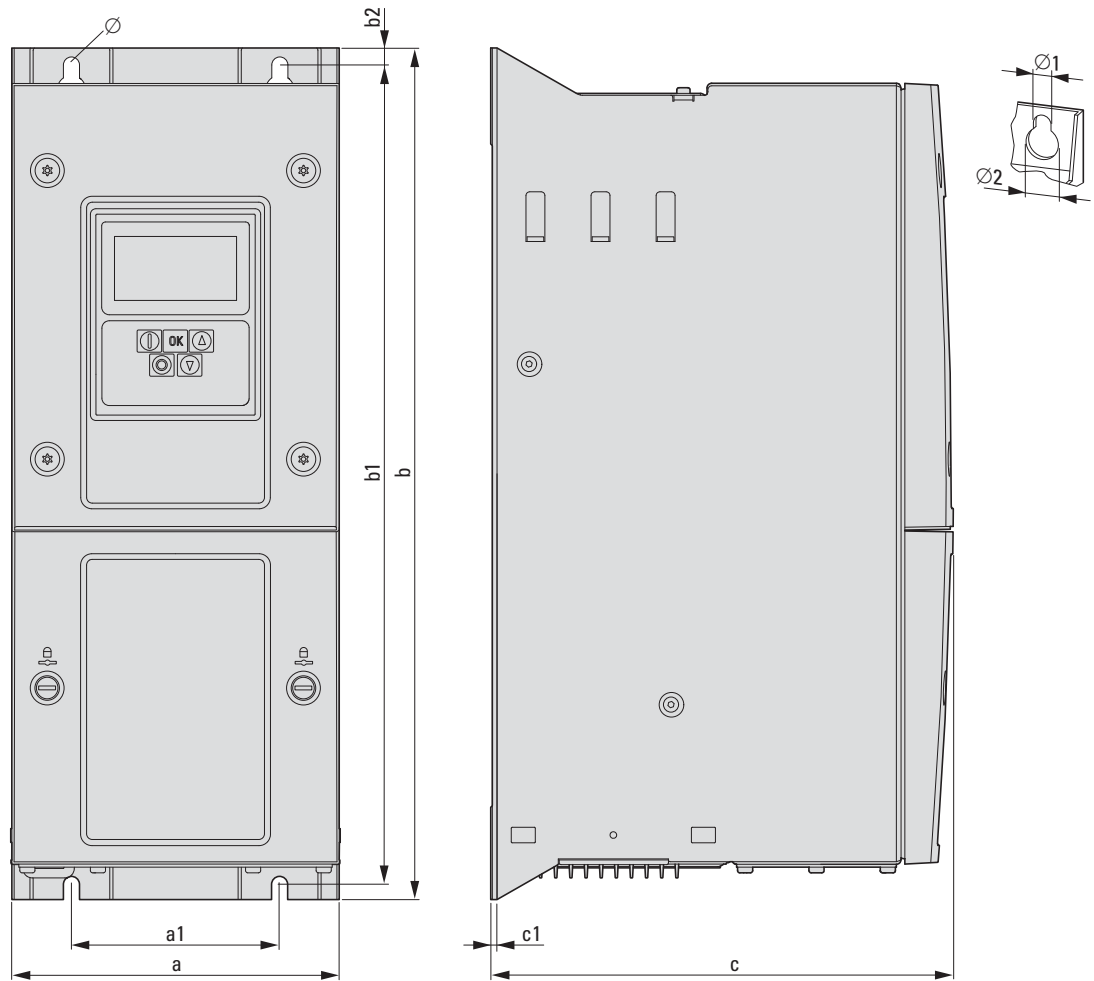

Figure 81: Frame sizes FS4 to FS8

Table 23: Dimensions and frame size

Frame size	a [mm] (in)	a1 [mm] (in)	b [mm] (in)	b1 [mm] (in)	b2 [mm] (in)	c [mm] (in)	c1 [mm] (in)	Ø1 [mm] (in)	Ø2 [mm] (in)
FS2	107 (4.2)	75 (3)	231 (9.1)	215 (8.5)		185.5 (7.3)	5 (0.2)	6.5 (0.26)	12.2 (0.48)
FS3	131 (5.2)	100 (3.9)	273 (10.8)	255 (10)		204 (8)	5 (0.2)	6.5 (0.26)	12.2 (0.48)
FS4	173 (6.8)	110 (175)	450 (17.7)	433 (17.1)		245 (9.7)	2 (0.79)	8 (0.32)	15 (0.59)
FS5	236 (9.3)	175 (6.9)	540 (21.3)	520 (20.5)		255 (10)	2 (0.79)	8 (0.32)	15 (0.59)
FS6	330 (13)	200 (7.9)	865 (34.1)	840 (33.1)		330 (13)	2 (0.79)	11 (0.43)	22 (0.87)
FS7	360 (14.2)	200 (7.9)	1280 (50.4)	1255 (49.5)		360 (14.2)	2 (0.79)	11 (0.43)	22 (0.87)
FS8	500 (19.7)	350 (13.8)	2000 (78.7)	1217 (47.9)		516 (20.3)		19 (0.75)	35 (1.38)

1 in = 1" = 25.4 mm, 1 mm = 0.0394 in

9.3 PC interface card

9.3.1 DX-COM-STICK

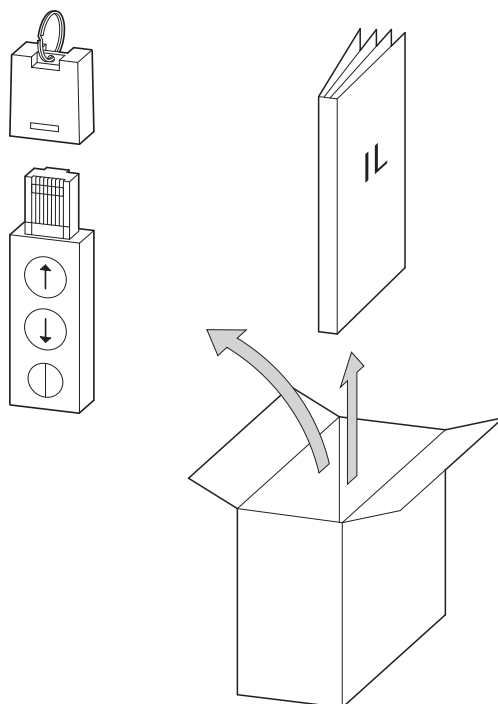

Figure 82: Equipment supplied DX-COM-STICK

- DX-COM-STICK PC connection module
- Installation instructions



The DX-COM-STICK PC connection card is not supplied with the DA1 variable frequency drive.

The DX-COM-STICK computer interface module is designed to enable Bluetooth communications between a DA1 series variable frequency drive and a computer with a Windows operating system and a Bluetooth port (point-to-point connection). Together with the drivesConnect parameter configuration program, you can:

- Upload and download all parameters
- Save parameters, compare them to each other, and print them out in parameter lists
- Show graphs vs. time with the monitor display function.
You can then save the oscillograms on your computer and print them.

The DX-COM-STICK computer interface module can be installed and connected without tools. Simply plug it into the bottom part of the DA1 variable frequency drive.

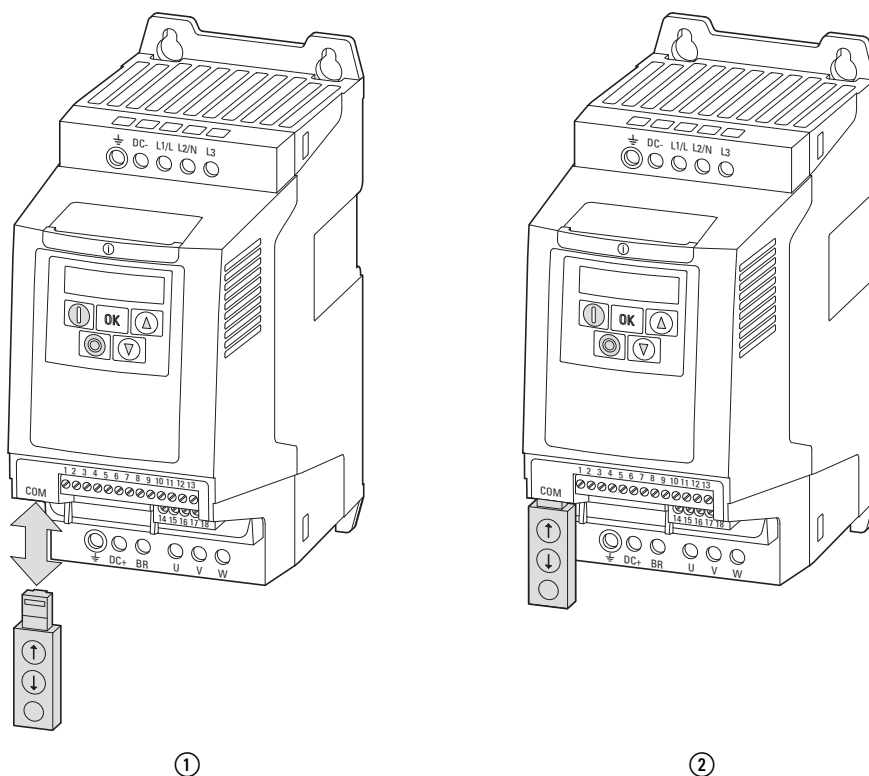

Figure 83: Mounting DX-COM-STICK

- ① Fitting or removing DX-COM-STICK
- ② DX-COM-STICK ready for operation

To remove the DX-COM-STICK module, simply pull it downwards.

If the DA1 variable frequency drive's supply voltage is on and a DX-COM-STICK module is plugged in, the parameters can be copied with the two function keys:

- ⬆ The parameters are loaded from the DX-COM-STICK to the variable frequency drive
- ⬇ The parameters from the variable frequency drive are loaded in the DX-COM-STICK.

➔ In order to upload or download the parameters, for example for the commissioning of series machines, the variable frequency drive must be connected to the mains voltage.

An active data transfer is indicated by the green flashing LED.

Table 24: Values that the DA1 variable frequency drive display may show after a data transfer

Indicator	Explanation
<i>PR55-r</i>	Parameter transfer to DX-COM-STICK interface card was successful
<i>DS-Loc</i>	DX-COM-STICK is interlocked. In order to transfer data, check the switch position on the side.
<i>FRIL-r</i>	Error while attempting to read the parameters from the variable frequency drive.
<i>PR55-t</i>	Parameter transfer to variable frequency drive successful.
<i>FRIL-P</i>	The parameter set stored in the DX-COM-STICK is for a different output variable (different motor current, motor output, etc.) than that of the connected variable frequency drive.
<i>FRIL-t</i>	Error when attempting to copy parameter set to variable frequency drive
<i>no-dAt</i>	No data found in DX-COM-STICK.
<i>dr-Loc</i>	Parameter set in variable frequency drive locked. Unlock variable frequency drive first.
<i>dr-rUn</i>	The variable frequency drive has an enable signal and cannot take new parameters. Stop the variable frequency drive.
<i>tYPE-E</i>	The parameter set stored in the DX-COM-STICK does not match the variable frequency drive. Only transfers from the variable frequency drive to the DX-COM-STICK are possible.
<i>tYPE-F</i>	The DX-COM-STICK is not compatible with the variable frequency drive.

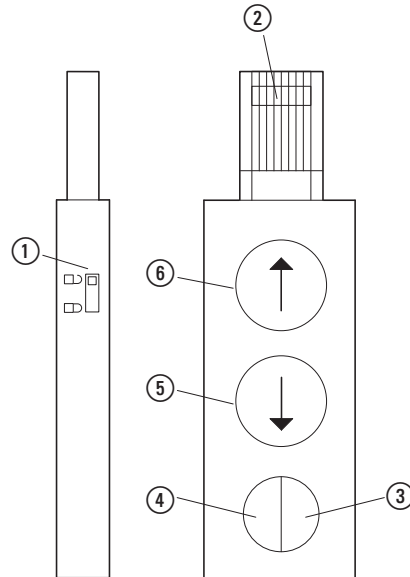

Figure 84: DX-COM-STICK

- ① RJ45 plug
- ② Parameter Lock
- ③ Status LED, green
- ④ Status LED, blue
- ⑤ Parameters Upload
- ⑥ Parameters Download

9 Appendix

9.3 PC interface card

9.3.2 drivesConnect

The drivesConnect parameter software allows fast parameterization, operation, diagnostics and documentation (printout and storage of parameter lists) via a PC and the data transfer with one or more DA1 variable frequency drive.

The drivesConnect program is found in the CD enclosed and can also be downloaded for free on the Internet.

9.3.3 Cables and fuses

The cross-sections of the cables and cable protection fuses used must correspond with local standards.

For an installation in accordance with UL Standards, the fuses and copper cable that are UL-approved and have a heat-resistance of +60/75 °C are to be used.

Use power cables with insulation according to the specified mains voltages for the permanent installation. A screened cable is not required on the mains side. On the motor side however, a complete (360°), low-impedance, shielded cable is necessary.

The length of the motor cable depends on the RFI class.

NOTICE

Fuses and cables selected must always comply with the applicable regulations at the installation site.

9 Appendix

9.3 PC interface card

Table 25: Fuses and Maximum Cross-Sections

Device type	F1, Q1		L1/L, L2/N, L3		U, V, W		PE		DC+, DC-, BR	
	1~	3~	mm ²	AWG ¹⁾	mm ²	AWG ¹⁾	mm ²	AWG ¹⁾	mm ²	AWG ¹⁾
DA1-124D3...	16 15 ²⁾	-	2 x 2.5	2 x 12	3 x 1.5	3 x 14	2.5	12	1.5	14
DA1-127D0...	20	-	2 x 4	2 x 10	3 x 1.5	3 x 14	4	10	1.5	14
DA1-12011...	25	-	2 x 10	2 x 8	3 x 1.5	3 x 14	10	8	1.5	14
DA1-324D3...	-	10	3 x 1.5	3 x 14	3 x 1.5	3 x 14	1.5	14	1.5	14
DA1-327D0...	-	10	3 x 2.5	3 x 14	3 x 1.5	3 x 14	2.5	14	1.5	14
DA1-32011...	-	16 15 ²⁾	3 x 4	3 x 12	3 x 1.5	3 x 14	4	12	1.5	14
DA1-32018...	-	20	3 x 4	3 x 10	3 x 2.5	3 x 10	4	10	2.5	10
DA1-32024...	-	32 30 ²⁾	3 x 10	3 x 8	3 x 4	3 x 10	10	8	4	10
DA1-32024...	-	32 30 ²⁾	3 x 10	3 x 8	3 x 4	3 x 10	10	8	4	10
DA1-32039...	-	40 35 ²⁾	3 x 16	3 x 8	3 x 6	3 x 8	16	8	6	8
DA1-32046...	-	63 60 ²⁾	3 x 25	3 x 4	3 x 10	3 x 6	25	4	10	6
DA1-32061...	-	80	3 x 35	3 x 3	3 x 16	3 x 4	35	3	16	4
DA1-32072...	-	100	3 x 35	3 x 1	3 x 25	3 x 3	35	1	35	3
DA1-32090...	-	125	3 x 50	3 x 2/0	3 x 35	3 x 2	50	2/0	35	2
DA1-32110...	-	160 150 ²⁾	3 x 70	3 x 3/0	3 x 50	3 x 1/0	70	3/0	50	1/0
DA1-32150...	-	200 175 ²⁾	3 x 95	3 x 4/0	3 x 70	3 x 3/0	95	4/0	70	3/0
DA1-32180...	-	200	3 x 120	3 x 250	3 x 95	3 x 4/0	120	250	95	4/0
DA1-32202...	-	250 225 ²⁾	3 x 185	3 x 300	3 x 120	3 x 250	185	300	120	250
DA1-32248...	-	315 300 ²⁾	3 x (2 x 95)	3 x 500	3 x 150	3 x 350	2 x 95	500	150	350
DA1-342D2...	-	6	3 x 1.5	3 x 14	3 x 1.5	3 x 14	1.5	14	1.5	14
DA1-344D1...	-	6	3 x 1.5	3 x 14	3 x 1.5	3 x 14	1.5	14	1.5	14
DA1-345D8...	-	10	3 x 1.5	3 x 14	3 x 1.5	3 x 14	1.5	14	1.5	14
DA1-349D5...	-	16 15 ²⁾	3 x 2.5	3 x 12	3 x 1.5	3 x 14	2.5	12	1.5	14
DA1-34014...	-	16 15 ²⁾	3 x 4	3 x 12	3 x 1.5	3 x 12	4	12	1.5	12
DA1-34018...	-	25	3 x 4	3 x 8	3 x 2.5	3 x 10	4	8	2.5	10

9 Appendix

9.3 PC interface card

Device type	F1, Q1		L1/L, L2/N, L3		U, V, W		PE		DC+, DC-, BR	
	1~	3~	mm ²	AWG ¹⁾	mm ²	AWG ¹⁾	mm ²	AWG ¹⁾	mm ²	AWG ¹⁾
DA1-34024...	–	32 30 ²⁾	3 x 10	3 x 8	3 x 4	3 x 10	10	8	4	10
DA1-34024...	–	32 30 ²⁾	3 x 10	3 x 8	3 x 4	3 x 10	10	8	4	10
DA1-34030...	–	40	3 x 16	3 x 8	3 x 6	3 x 8	16	8	3	8
DA1-34039...	–	63 60 ²⁾	3 x 16	3 x 4	3 x 10	3 x 8	16	4	10	8
DA1-34046...	–	63 60 ²⁾	3 x 25	3 x 4	3 x 10	3 x 6	25	4	10	3
DA1-34061...	–	80	3 x 35	3 x 3	3 x 16	3 x 4	35	3	16	4
DA1-34072...	–	100	3 x 35	3 x 1	3 x 25	3 x 3	35	1	25	3
DA1-34090...	–	125	3 x 50	3 x 2/0	3 x 35	3 x 2	50	2/0	35	2
DA1-34110...	–	160 150 ²⁾	3 x 70	3 x 3/0	3 x 50	3 x 1/0	70	3/0	50	1/0
DA1-34150...	–	200 175 ²⁾	3 x 95	3 x 4/0	3 x 70	3 x 3/0	95	4/0	70	3/0
DA1-34180...	–	200	3 x 120	3 x 250	3 x 95	3 x 4/0	150	250	95	4/0
DA1-34202...	–	250	3 x 185	3 x 400	3 x 120	3 x 250	185	400	120	250
DA1-34240...	–	315 300 ²⁾	3 x (2 x 95)	3 x 500	3 x 150	3 x 350	2 x 95	500	150	350
DA1-34302...	–	400 350 ²⁾	3 x (2 x 95)	3 x 700	3 x (2 x 70)	3 x 500	2 x 95	700	2 x 70	500





1) 1) AWG = American Wire Gauge





2) UL fuse with AWG

9 Appendix

9.3 PC interface card

Table 26: Specified fuses

Part no. DA1	Maximum permissible supply voltage U_{LN} [V]			 ²⁾	 ³⁾
		VDE [A]	UL ¹⁾ [A]	Part no. Eaton	
DA1-124D3...	1 AC 240 V +10 %	16	15	FAZ-B16/1N	-
DA1-127D0...	1 AC 240 V +10 %	25	20	FAZ-B20/1N	-
DA1-12011...	1 AC 240 V +10 %	25	25	FAZ-B32/1N	-
DA1-324D3...	3 AC 240 V +10 %	10	10	FAZ-B6/3	PKM0-6,3
DA1-327D0...	3 AC 240 V +10 %	10	10	FAZ-B10/3	PKM0-10
DA1-32011...	3 AC 240 V +10 %	16	15	FAZ-B16/3	PKM0-16
DA1-32018...	3 AC 240 V +10 %	20	20	FAZ-B20/3	PKM0-20
DA1-32024...	3 AC 240 V +10 %	32	30	FAZ-B32/3	PKM0-32
DA1-32039...	3 AC 240 V +10 %	40	35	FAZ-B50/3	-
DA1-32046...	3 AC 240 V +10 %	63	60	FAZ-B63/3	-
DA1-32061...	3 AC 240 V +10 %	80	80	-	NZMC1-S80
DA1-32072...	3 AC 240 V +10 %	100	100	-	NZMC1-S80
DA1-32090...	3 AC 240 V +10 %	125	125	-	NZMC2-S100
DA1-32110...	3 AC 240 V +10 %	160	150	-	NZMC2-S125
DA1-32150...	3 AC 240 V +10 %	200	175	-	NZMC2-S160
DA1-32180...	3 AC 240 V +10 %	200	200	-	NZMC3-S200
DA1-32202...	3 AC 240 V +10 %	250	225	-	NZMC3-S250
DA1-32248...	3 AC 240 V +10 %	315	300	-	NZMC3-S320
DA1-342D2...	3 AC 480 V +10 %	6	6	FAZ-B6/3	PKM0-6,3
DA1-344D1...	3 AC 480 V +10 %	6	6	FAZ-B6/3	PKM0-6,3
DA1-345D8...	3 AC 480 V +10 %	10	10	FAZ-B10/3	PKM0-10
DA1-349D5...	3 AC 480 V +10 %	16	15	FAZ-B16/3	PKM0-16
DA1-34014...	3 AC 480 V +10 %	16	15	FAZ-B20/3	PKM0-20
DA1-34018...	3 AC 480 V +10 %	25	25	FAZ-B25/3	PKM0-25
DA1-34024...	3 AC 480 V +10 %	32	30	FAZ-B32/3	PKM0-32
DA1-34030...	3 AC 480 V +10 %	40	40	FAZ-B50/3	-
DA1-34039...	3 AC 480 V +10 %	63	60	FAZ-B6/3	-
DA1-34046...	3 AC 480 V +10 %	63	60	FAZ-B63/3	-
DA1-34061...	3 AC 480 V +10 %	80	80	-	NZMC1-S80
DA1-34072...	3 AC 480 V +10 %	100	100	-	NZMC1-S80
DA1-34090...	3 AC 480 V +10 %	125	125	-	NZMC1-S100
DA1-34110...	3 AC 480 V +10 %	160	150	-	NZMC2-S125
DA1-34150...	3 AC 480 V +10 %	200	175	-	NZMC2-S160
DA1-34180...	3 AC 480 V +10 %	200	200	-	NZMC2-S200

Part no. DA1	Maximum permissible supply voltage			 2)	 3)
	U _{LN} [V]	VDE [A]	UL ¹⁾ [A]	Part no. Eaton	
DA1-34202...	3 AC 480 V +10 %	250	250	-	NZMC3-S250
DA1-34240...	3 AC 480 V +10 %	315	300	-	NZMC3-S320
DA1-34302...	3 AC 480 V +10 %	400	350	-	NZMC3-S320

1) Fuse UL-rated, class J, 600 V

2) I_{cn} = 10 kA

3) I_{cn} = 50 kA

9.4 Mains contactors



The mains contactors listed here have been selected based on the variable frequency drive's input-side rated mains current I_{LN} without a main choke. The contactor should be selected based on thermal current I_{th} = I_e (AC-1) at the specified ambient temperature.

NOTICE

The inching operation is not permissible via the mains contactor (Pause time ≥ 60 s between switching off and on).



Technical data on the mains contactors can be found in the main catalog HPL, Contactors DILEM and DILM.

DILM12-XP1

P1DILEM

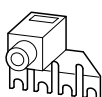

DILM,

DILEM

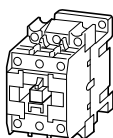

DILM12-XP1

P1DILEM

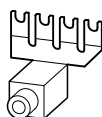

Figure 85: Mains contactor at single-phase connection



For UL-compliant installation and operation, the mains side switching devices must allow for a 1.25 times higher input current. The devices meet this requirement.

9 Appendix

9.4 Mains contactors

Table 27: Assigned mains contactors

Part no. DA1	Rated operating voltage		Rated input current	Related mains contactor		
	(50 Hz)	(60 Hz)		Part no.	Thermal current AC-1	
	U_{LN}	U_{LN}	I_{LN} [A]		I_N [A] (+50 °C)	I_N [A] (+40 °C)
DA1-124D3...	1 AC 230 V	1 AC 240 V	8.5	DILM7	21	22
DA1-127D0...	1 AC 230 V	1 AC 240 V	13.9	DILM7	21	22
DA1-12011...	1 AC 230 V	1 AC 240 V	19.5	DILM17	38	40
DA1-324D3...	3 AC 230 V	3 AC 240 V	4.5	DILM7	21	22
DA1-327D0...	3 AC 230 V	3 AC 240 V	7.3	DILM7	21	22
DA1-32011...	3 AC 230 V	3 AC 240 V	11	DILM17	38	40
DA1-32018...	3 AC 230 V	3 AC 240 V	18.8	DILM17	38	40
DA1-32024...	3 AC 230 V	3 AC 240 V	24.8	DILM17	38	40
DA1-32039...	3 AC 230 V	3 AC 240 V	40	DILM40	57	60
DA1-32046...	3 AC 230 V	3 AC 240 V	47.1	DILM50	71	80
DA1-32061...	3 AC 230 V	3 AC 240 V	62.4	DILM65	88	98
DA1-32072...	3 AC 230 V	3 AC 240 V	74.1	DILM95	125	130
DA1-32090...	3 AC 230 V	3 AC 240 V	92.3	DILM115	142	160
DA1-32110...	3 AC 230 V	3 AC 240 V	112.7	DILM150	180	190
DA1-32150...	3 AC 230 V	3 AC 240 V	153.5	DILM185A	301	337
DA1-32011...	3 AC 230 V	3 AC 240 V	183.8	DILM185A	301	337
DA1-32202...	3 AC 230 V	3 AC 240 V	206.2	DILM185A	301	337
DA1-32248...	3 AC 230 V	3 AC 240 V	252.8	DILM250	360	400
DA1-342D2..	3 AC 400 V	3 AC 480 V	2.4	DILM7	21	22
DA1-344D1...	3 AC 400 V	3 AC 480 V	4.3	DILM7	21	22
DA1-345D8...	3 AC 400 V	3 AC 480 V	6.1	DILM7	21	22
DA1-349D5...	3 AC 400 V	3 AC 480 V	9.8	DILM7	21	22
DA1-34014...	3 AC 400 V	3 AC 480 V	14.6	DILM17	38	40
DA1-34018...	3 AC 400 V	3 AC 480 V	18.1	DILM17	38	40
DA1-34024...	3 AC 400 V	3 AC 480 V	24.7	DILM17	38	40
DA1-34030...	3 AC 400 V	3 AC 480 V	30.8	DILM40	57	60
DA1-34039...	3 AC 400 V	3 AC 480 V	40	DILM50	71	80
DA1-34046...	3 AC 400 V	3 AC 480 V	47.1	DILM50	71	80
DA1-34061...	3 AC 400 V	3 AC 480 V	62.8	DILM80	98	110
DA1-34072...	3 AC 400 V	3 AC 480 V	73.8	DILM95	125	130
DA1-34090...	3 AC 400 V	3 AC 480 V	92.2	DILM115	142	160
DA1-34110...	3 AC 400 V	3 AC 480 V	112.5	DILM150	180	190
DA1-34150...	3 AC 400 V	3 AC 480 V	153.2	DILM185A	301	337
DA1-34180...	3 AC 400 V	3 AC 480 V	183.7	DILM185A	301	337
DA1-34202...	3 AC 400 V	3 AC 480 V	205.9	DILM185A	301	337
DA1-34240...	3 AC 400 V	3 AC 480 V	244.5	DILM250	360	400
DA1-34302...	3 AC 400 V	3 AC 480 V	307.8	DILM300A	385	430

Alphabetical index

Numericals

87-Hz Characteristic curve 40

A

Abbreviations 6

AC-voltage system 30

Air

 Baffle 47

 Circulation 46

Ambient Temperature 24

Analog Input 136

B

Block diagram

 DA1 assemblies 22

Brake chopper 13, 14, 19

Bus termination resistor 71

Bypass operation 42

C

Cable

 Fuse protection and max.
 conductor cross sections 215

Cable cross-sections 34

Catalog number selection 14

CE-Approval mark 25

checklist 75

Circuit type 24, 40

Clearances, thermal 46

Commissioning 75

Commutating choke, see main choke 33

Conformity (CE) 37

Connecting the control section 64

Connecting the power section 59

Connection

 asymmetrically earthed network 30

 Cable, screened 62

 Control signal terminal, example 77

 Digital input 70

 EX motors 43

 in control section 64

 in power section 59

 motor (block diagram) 22

Connection to IT networks 25

Control cables 56

Control inputs

 Default settings 67

Control panel

 mounting 49

 surface, calculation 49

Control panel dimensioning 49

Control signal terminals

 Designation 65

 Function 66

Control terminal strip 64

Cooling 46

CRC (Cyclical Redundancy Check) 175

D

DA1

 Selection criteria 24

 System overview 10

 Voltage categories 13

DC current braking 162

DC link voltage 27

Default settings 6

Degree of protection 13, 19

Degrees of protection 9

Delta circuit 40

Digital input

 Connection 70

Digital output

 Connection 70

Dimensions 209

Display unit 14, 130

DS (default setting) 6

E

Earth-fault loop impedance 54

Earth-fault protection 55

Earthing 54

Electrical Installation 58

Electrical power network 30

EMC

 Compliant setup, example 57

 Earthing 54

 electromagnetic compatibility 6

 Measures in the control panel 53

 measures, general 36

 Screen earth kit 56

EMC screw 30, 55

Emitted interference 37

EMT6 43

Engineering 29

Equipment supplied	11	Instructional leaflet	12
Error		IL04020009Z	12
memory	81	IL04020013Z	12
messages	81	IL04020014Z	12
ESD measures	65	Insulation	
Ex motors	43	Resistance	74
F		Test	74
Fault current (to earth)	55	Interference immunity	37
FE, see functional earth	6	Internal DC link	22
Features	19	Internal DC link capacitors	27
Fixed frequency	155	Inverter, block diagram	22
Fixed frequency setpoint values	155	IT network, connection	30
Fixing		L	
on mounting rail	51	LCD	6
with screws	50	Leakage Current	35, 53, 58
Frame sizes		Load Torque	24
Radio interference suppression filter	209	M	
Frequency	31	Magnet system	29
frequency jump	150	Main choke	33
FS (frame size, size)	6	Mains cable insulation	74
Functional earth	6	Mains contactor	36
Fuses	34	Mains form	30
FWD (forward run, clockwise rotation field)	6	Mains supply voltages	7
G		Mains voltage	24, 31
GND (ground)	6	North American	7
Guidelines		Maintenance	26
73/23/EEC	25	Manufacturing date	13
89/336/EEC	25	Menu navigation (operating unit)	130
89/392/EEC	25	Modbus	
93/68/EEC	25	Parameters	173
H		Register mapping	177
Harmonics	33	RTU	171, 174
Hazard warnings, operational	76	Motor	
Heat dissipation	49	Cable insulation check	74
Heat transfer coefficient	49	Cable, screened	63
Hotline (Eaton Industries GmbH)	27	connection, block diagram	22
I		explosion-proof	43
I/O (Control signal terminals)	65	Insulation test	74
IGBT	6	selection	38
Immission	37	Motor cable	34
Inching operation	77	Motor earthing	55
Incoming unit, block diagram	22	Motor potentiometer	138
Input process data	177	Mounting	45
Inspection	26	Mounting position	46
Installation	45	N	
EMC-compatibility	53	Nameplate	13

O	
Operating mode	
speed control	38
V/Hz control	38
Operating unit	129
block diagram	23
Operational data indicator	168
P	
Parallel	
connection of several motors	24
operation, multiple motors	38
resonances	33
Parameter software MaxConnect	214
Parameters	
Setting	130
Upload/Download	212
PDS (power drive system)	6
PE	6
PES (protective earth shielding)	6
PNU (parameter number)	6
Point-to-point connection	211
Power Drive System	29
Power networks	
AC	30
Grounded star point	7
phase-earthed delta networks	30
Ring	7
Star	7
Power supply	24
Power Wiring	30
Protective earth	6, 54
R	
Radio interference	36
Radio interference filter	
Block diagram	22
Rated data	13
Rated motor current	24
Rated operational data	
general	16
nameplate	13
Rating plate	40
Reactive power compensation devices	33
Rectifier bridge	22
Redundancy check, cyclic	175
Relay outputs	70
Residual current circuit breaker, see residual current device	35
Residual current device	35
REV (reverse run, anticlockwise rotation field active)	6
RJ45 interface	71
RS45 interface	71
S	
Scaled value range	137
Screen earth kit	56
Selection criteria, for variable frequency drives	24
Self-test	130
Serial interface	171
Serial number	13
Service	27
Setpoint input	169
Signal cables	56
Sinusoidal filter	24, 43
Slip	158
Slip compensation	158
Speed behavior	
with slip compensation	159
without slip compensation	158
Standards	
EN 50178	34, 35
EN 60204	25, 34
EN 60335	53
EN 60529	45
IEC 60034-1	38
IEC 60038	31
IEC 60364	30
IEC 60947	36
IEC 61557-8	56
IEC 755	35
IEC 890	49
IEC/EN 60715	51
IEC/EN 61800-3	32, 36
IEC/EN 61800-5-1	58
VDE 0113	34
VDE 0160	34, 53
VDE 017-1	31
VDE 0289	34
Star connection	40
Starting torque	24
Stator windings, motor	153
Storage	26
Supply voltage	58
Support (Eaton Industries GmbH)	6, 191
Surface mounting, EMC-compliant	57
System earthing	54

T

Technical data	
Cables and fuses	215
Temperature class	40
Terminations	61
THD (Total Harmonic Distortion)	32
Three-phase asynchronous motor	22
Three-wire control	143
Total harmonic distortion	33
Transistor output	70
Two-wire control	140
Type	
designation	13

U

UL (Underwriters Laboratories)	6
Units	7
Use (intended)	25

V

V/f-characteristic curve	41
VAR screw	56
Voltage balance	31
Voltage drop, permissible	7

W

Warnings	83
Warranty	27