



# *GE Fanuc Automation*

---

*Computer Numerical Control Products*

*Series 15 / 150 – Model B*

*Maintenance Manual*

GFZ-62075E/03

February 1995

## *Warnings, Cautions, and Notes as Used in this Publication*

### **Warning**

Warning notices are used in this publication to emphasize that hazardous voltages, currents, temperatures, or other conditions that could cause personal injury exist in this equipment or may be associated with its use.

In situations where inattention could cause either personal injury or damage to equipment, a Warning notice is used.

### **Caution**

Caution notices are used where equipment might be damaged if care is not taken.

### **Note**

Notes merely call attention to information that is especially significant to understanding and operating the equipment.

This document is based on information available at the time of its publication. While efforts have been made to be accurate, the information contained herein does not purport to cover all details or variations in hardware or software, nor to provide for every possible contingency in connection with installation, operation, or maintenance. Features may be described herein which are not present in all hardware and software systems. GE Fanuc Automation assumes no obligation of notice to holders of this document with respect to changes subsequently made.

GE Fanuc Automation makes no representation or warranty, expressed, implied, or statutory with respect to, and assumes no responsibility for the accuracy, completeness, sufficiency, or usefulness of the information contained herein. No warranties of merchantability or fitness for purpose shall apply.

<b>1. GENERAL</b> .....	<b>1</b>
1.1 Configuration of the CNC Control Equipment .....	3
1.1.1 Configuration of the CNC control unit .....	3
1.1.2 Configuration of the printed circuit boards in the CNC control unit .....	5
1.1.3 Configuration of the CRT/MDI unit .....	5
1.2 Block Diagram for the CNC Control Unit .....	6
1.3 List of the Printed Circuit Boards and Units of Series 15-B .....	9
<b>2. MAINTENANCE EQUIPMENT</b> .....	<b>16</b>
2.1 Maintenance Equipment .....	16
2.2 Main Spare Parts .....	16
<b>3. TROUBLESHOOTING AND ACTION TO BE TAKEN</b> .....	<b>17</b>
3.1 Procedures for Troubleshooting .....	17
3.2 Problems and Corrective Measures .....	17
3.2.1 System alarm .....	17
3.2.2 Action to be taken when an error code is displayed .....	18
3.2.3 Lighting of alarm LEDs on PCBs .....	22
3.2.4 The machine cannot be operated in the jog mode. ....	23
3.2.5 The machine cannot be operated by the manual pulse generator. ....	24
3.2.6 The spindle cannot be operated in the synchronous feed mode. ....	24
3.2.7 The machine cannot be operated in the automatic mode. ....	25
3.2.8 The input/output unit of the reader/punch interface do not operate correctly. ....	26
3.2.9 The machine does not return to the correct reference position. ....	27
3.3 Displaying Conditions Using the Self-diagnosis Function .....	30
3.3.1 Diagnosis function for the interface with machine tools .....	30
3.3.2 Function to display the CNC internal status .....	31
3.4 Displaying System Configurations .....	39
<b>4. CONFIRMING POWER SOURCE VOLTAGE AND POWER CONNECTION</b> .....	<b>44</b>
4.1 Confirming Power Source Voltage .....	44
4.1.1 Power supply in the control unit .....	44
4.1.2 Servo amplifier .....	46
4.1.3 Checking the ground connection .....	46
4.2 Confirmation of Power Supply Connection .....	47
4.2.1 Tap change of control power transformer .....	47
4.2.2 Connection of AC servo power transformer .....	47
4.3 Confirming CNC Control Unit Connection .....	48
4.3.1 Series 15-MB total connection diagram (In case of serial spindle) .....	48
4.3.2 Connection of FANUC I/O Link .....	51
4.3.3 Optical fiber cable .....	54
4.3.4 Connection of I/O Unit-MODEL A .....	58

4.3.5	Connection with Connection unit .....	62
4.3.6	Connection of operator's panel connection unit .....	63
4.3.7	CRT display interface .....	66
4.3.8	LCD-PDP display interface .....	67
4.3.9	Keyboard interface .....	67
4.3.10	Manual pulse generator interface .....	68
4.3.11	Remote buffer interface (RS-232-C) .....	68
4.3.12	Remote buffer interface (RS-422) .....	69
4.4	Confirmation of Connection between CNC Control Unit and Servo .....	70
4.5	Confirming the Connection between the CNC Control Unit and Spindle Motor .....	74
4.6	Confirming the Connection between the NC Control Unit and I/O devices .....	77
4.6.1	RS-232-C serial port .....	77
4.6.2	PPR connection .....	78
4.6.3	Portable tape reader connection .....	79
4.6.4	FANUC Cassette connection .....	80
4.6.5	Connection of tape reader without reels .....	81
4.6.6	Connection of tape reader with reels .....	82
<b>5.</b>	<b>STARTUP AND ADJUSTMENTS .....</b>	<b>83</b>
5.1	Startup and Adjustment Procedures .....	83
5.2	Adjusting a Flat Display .....	87
<b>6.</b>	<b>DISPLAYING AND SPECIFYING PARAMETERS .....</b>	<b>88</b>
6.1	Displaying Parameters .....	88
6.1.1	Displaying parameters other than those related to pitch error compensation .....	88
6.1.2	Displaying parameters related to pitch error compensation .....	88
6.2	Specifying Parameters .....	89
6.2.1	Formats of parameter tapes .....	89
6.2.2	Specifying parameters through the reader/punch interface .....	91
6.2.3	Specifying parameters through the MDI .....	91
6.3	Outputting Parameters .....	92
6.3.1	Outputting all parameters .....	92
6.3.2	Outputting the parameters excluding those related to pitch error compensation .....	92
6.3.3	Outputting parameters for pitch error compensation .....	92
6.4	Parameters .....	93
6.5	Setting and Displaying PMC Data (using the PCPRM soft key) .....	103
6.5.1	Setting and displaying timer data .....	103
6.5.2	Setting and displaying counter data .....	104
6.5.3	Setting and displaying keep relay data and data for controlling the retained memory .....	104
6.5.4	Setting and displaying data in the data table .....	105
6.5.5	Inputting and outputting PMC data (when the reader/punch interface is used) .....	107
6.6	Input/Output of CNC Data .....	111

6.6.1	Setting the parameters necessary for input/output	111
6.6.2	Outputting CNC parameters	115
6.6.3	Outputting part programs	115
6.6.4	Outputting offset data	115
6.6.5	Inputting CNC parameters	115
6.6.6	Inputting part programs	115
6.6.7	Inputting offset data	116
<b>7.</b>	<b>CONFIGURATION OF THE PRINTED CIRCUIT BOARDS IN THE CONTROL UNIT</b>	<b>117</b>
7.1	Power Unit Configuration	117
7.2	Configuration of the CPU Board (MAIN-B)	119
7.3	Configuration of the Main CPU Board (MAIN-A)	123
7.4	Configuration of the Upgraded Main CPU Board (MAIN-C)	127
7.5	Configuration of the High-Speed Multiaxis Main CPU Board (MAX MAIN-A)	130
7.6	Configuration of the PMC-NA Board	134
7.7	Configuration of the PMC-NA Board with or without the Conversational Function	137
7.8	Configuration of the PMC-NB Board with or without the Conversational Function	140
7.9	Configuration of the Axis CPU Board (ACPU)	143
7.10	Configuration of the Multiaxis Buffer Board	146
7.11	Configuration of the RISC Board	148
7.12	Configuration of the Sub. CPU board (SUB-A)	150
7.13	Configuration of the Standard Multiaxis Sub-CPU Board (MAX SUB-B)	153
7.14	Configuration of the Upgraded Sub-CPU Board (SUB-C)	156
7.15	Configuration of additional axis (ADAX) board	159
7.16	Configuration of the option 1 board	161
<b>8.</b>	<b>HOW TO REPLACE FUSES, PRINTED CIRCUIT BOARDS, AND OTHER UNITS</b>	<b>165</b>
8.1	How to Replace the Fuses in the Power Supply Unit	165
8.2	How to Replace the Power Supply Unit	166
8.3	How to Replace the Printed Circuit Boards in the Control Unit	167
8.4	How to Replace the Modules	168
8.5	How to Replace the Batteries	169
8.5.1	Procedure for replacing the dry cell for the control unit (memory back-up)	169
8.5.2	Procedure for replacing the dry cell for the absolute pulse coder	170
8.6	How to Replace the Fan Motor	171
8.7	How to Replace the Card Cage in the Control Unit	172
8.8	How to Replace the MDI Keyboard	173
8.9	How to Replace the CRT Display	174

**APPENDIX**

- 1. SYSTEM ALARMS ..... 177**
  - 1.1 System Alarms When the CNC System Is Turned On ..... 177
  - 1.2 System Alarms While the CNC System Is Operating ..... 179
    - 1.2.1 System alarm screen ..... 179
    - 1.2.2 Software series and edition ..... 179
    - 1.2.3 System alarms (SYSTEM ALARM FACTOR) ..... 180
  - 1.3 Program Counter (PROG COUNT) ..... 182
  - 1.4 CPU Status (CPU STATUS) ..... 182
  - 1.5 User Number for the Active Task (ACT TASK) ..... 182
  - 1.6 Address at which an Error Occurred (ERROR ADRS) ..... 182
  - 1.7 Master CPU of the Bus (BUS MASTER) ..... 182
  - 1.8 Hardware Status (HARD INFORMATION) ..... 183
  - 1.9 Software Status (SOFT INFORMATION) ..... 183
- 2. DISPLAYING THE SYSTEM LOG SCREEN ..... 184**
- 3. SIGNAL INTERFACE LIST BETWEEN CNC AND PMC ..... 185**

## 1. GENERAL

This manual describes preventive maintenance, quick troubleshooting procedures, check points, adjustments, and parameter details. It also covers various additional technical information (Appendixes).

Refer to the OPERATOR'S MANUAL and CONNECTING MANUAL, as required.

The CNC is an integral part of the CNC machine tool. A dust-proof enclosed structure, a cooling method, and wiring between units are designed and manufactured by each machine tool builder. Refer to the machine tool builder manual that addresses these issues.

Refer to the following materials for the details of the information listed below:

Parameters for the digital servo unit: FANUC AC SERVO AMPLIFIER MAINTENANCE MANUAL (B-65005E)  
FANUC AC SERVO MOTOR  $\alpha$ Series PARAMETER MANUAL (B-65150E)

DI/DO interface between the CNC and PMC: FANUC Series 15-MODEL B CONNECTION MANUAL (B-62073E)

Related manuals of FANUC Series 15-MODEL B are as follows:

FANUC Series 15-MODEL B DESCRIPTION (B-62072E)

FANUC Series 15/150-MODEL B CONNECTION MANUAL (B-62073E)

FANUC Series 15-MODEL B CONNECTION MANUAL (BMI interface) (B-62073E-1)

FANUC Series 15-MODEL B For Lathe OPERATOR'S MANUAL (PROGRAMMING) (B-62554E/01)

FANUC Series 15-MODEL B For Lathe OPERATOR'S MANUAL (OPERATION) (B-62554E-1/01)

FANUC Series 15-MODEL B For Machining Center OPERATOR'S MANUAL (PROGRAMMING) (B-62564E/01)

FANUC Series 15-MODEL B For Machining Center OPERATOR'S MANUAL (OPERATION) (B-62564E-1/01)

FANUC Series 15-MODEL B PARAMETER MANUAL (B-62560/01)

\* FANUC Series 15/150-MODEL B MAINTENANCE MANUAL (B-62075E)

FANUC PMC-MODEL N/NA PROGRAMMING MANUAL (Ladder Language) (B-61013E)

FANUC PMC-MODEL N/NA PROGRAMMING MANUAL (PASCAL Language) (B-61013E-1)

FANUC PMC-MODEL N/NA PROGRAMMING MANUAL (C Language) (B-61013E-2)

CONVERSATIONAL AUTOMATIC PROGRAMMING FUNCTION FOR LATHE

(Series 16, Series 15-MODEL B) OPERATOR'S MANUAL (B-61804E-2)

CONVERSATIONAL AUTOMATIC PROGRAMMING FUNCTION FOR MACHINING CENTER

(Series 15-MF, Series 15-MFB) PROGRAMMING MANUAL (B-61263E)

CONVERSATIONAL AUTOMATIC PROGRAMMING FUNCTION FOR MACHINING CENTER

(Series 15-MF, Series 15-MFB) OPERATOR'S MANUAL (B-61264E)

\*This manual.

This manual describes the following products:

Product name	Abbreviations	
FANUC Series 15 – TB	15 – TB	Series 15 – B
FANUC Series 150 – TB		
FANUC Series 15 – TFB	15 – TFB	
FANUC Series 15 – TTB	15 – TTB	
FANUC Series 150 – TTB		
FANUC Series 15 – TTFB	15 – TTFB	
FANUC Series 15 – MB	15 – MB	
FANUC Series 150 – MB		
FANUC Series 15 – MFB	15 – MFB	

**NOTE** For maintenance of FANUC MMC-IV, see “FANUC MMC-IV Connection and Maintenance Manual (B-62493E)”.

Explanation of terms frequently used in CNC are:

**Least input increment**

The minimum unit for program input of the move command

**Least command increment**

The minimum unit of a command to be given from CNC to the machine tool

**Detection unit**

The minimum unit of detectable axis move distance

**Command multiplier (CMR)**

A constant to enable the weight of CNC command pulses to match the weight of pulses from the detector

**Detection multiplier (DMR)**

A constant to enable the weight of CNC command pulses to match the weight of pulses from the detector

**NOTE** The relations among the least input increment, detection unit, CMR, and DMR are as specified below.

Least input increment= CMR × detection unit

Detection unit= Move amount per revolution of motor/(DMR × number of pulses of detector per revolution of motor)

The flexible feed gear function in the digital servo unit defines constant DMR using two parameters n and m (DMR = n/m).

**CRT/MDI panel**

CRT and Manual Data Input

This operator's panel is used to input command to CNC or display CNC conditions using key switches.

**Parameter**

A value set in the CNC which enables the CNC to fully utilize the machine tools functional characteristics.



## 1.1 Configuration of the CNC Control Equipment

The CNC control equipment consists of the following: the CNC control unit performing arithmetic processing for numerical control, the CRT/MDI unit displaying set data, the servo motors which actually operate the machine tool, and the servo amplifier. In this section, the structure and internal configuration of the CNC control unit and CRT/MDI unit will be outlined.

### 1.1.1 Configuration of the CNC control unit

The CNC control unit consists of the control unit rack, the power unit and printed circuit boards installed in the rack.

On top of the rack is a cooling fan motor. At the rear there is a back plane in which the printed circuit boards are plugged. As shown in the figure below, the upper cover of the control rack opens providing access to the fan motor for possible replacement.

The power unit is installed in the slot closest to the right edge of the rack. The PMC board is inserted into the second slot (slot 1) from the right rack edge. The main CPU board is inserted into the third slot (slot 2) from the right rack edge.

When sub CPU board (or additional axis board) is inserted, it is inserted into the fourth slot (slot 3) from the right rack edge. The remaining other slots are used for option boards. The sequence order of the option boards in the option slots makes no difference in the CNC operation. However, in order to avoid confusion, option boards are inserted according to kinds of the boards.

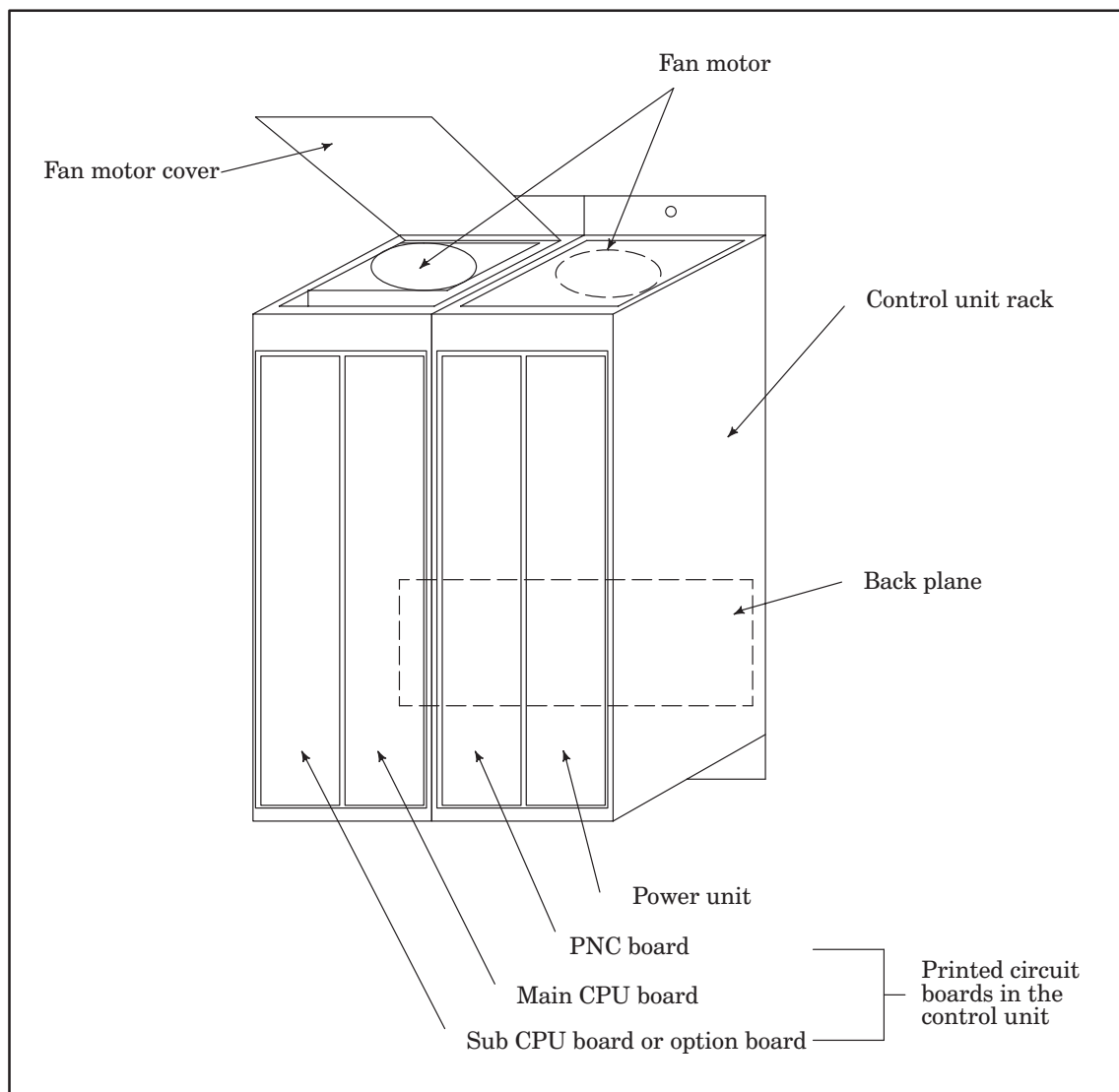

Fig. 1.1.1 (a) Control Unit Structure

Various racks for a control unit, power units, and printed circuit boards shown in the figure below can be used to configure a control units. Combination of these components depends on a machine tool for which the control unit is used.

Fig. 1.1.1 (b) shows the configuration of the control unit of the Series 15-B.

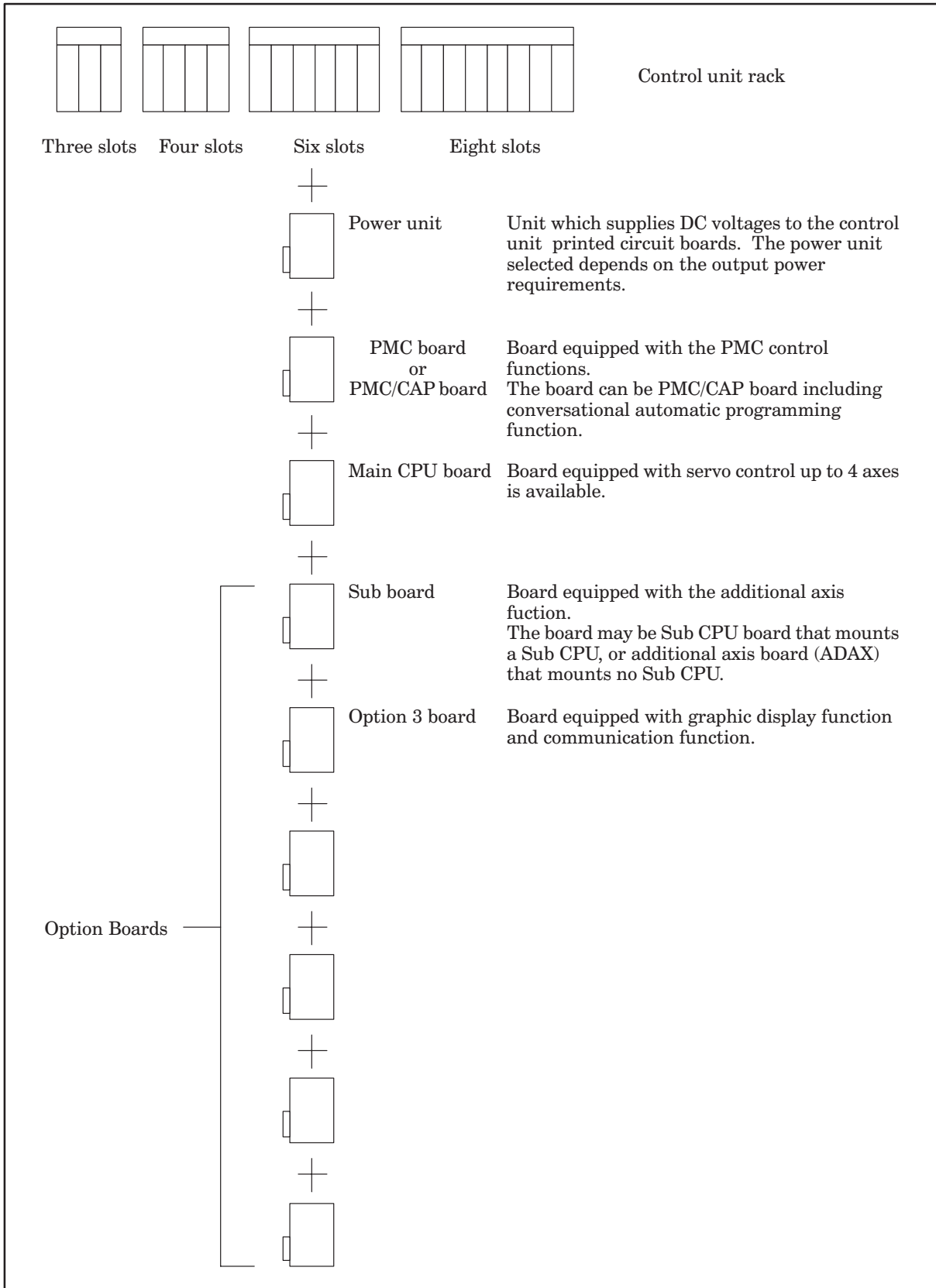

Fig. 1.1.1 (b) Configuration of the Control Unit (Series 15-B)

### 1.1.2 Configuration of the printed circuit boards in the CNC control unit

As shown in Fig. 1.1.2, a printed circuit board consists of a printed circuit board and a number of modules installed perpendicularly to the board.

At the front of a printed circuit board, the interface connectors and LED display are installed and a plastic front panel is attached. There is also a connector attached at the rear edge of the printed circuit board for connecting to the F-BUS back plane.

The modules are small printed circuit boards with surface mount devices mounted on both sides. One edge of each module board has connector electrodes. Module boards are attached by inserting them in the module connectors on the printed circuit board, simplifying the replacement of the module boards. There are a number of modules types available and the circuit function for each is different. Therefore, the connector location for installing each module on the printed circuit board is fixed. If a module is not installed in the correct connector, the system may fail to operate correctly and the circuitry of the control unit or the module itself may be damaged. However, some modules (ROM, SRAM, etc.) are interchangeable with respect to the signal assignment, enabling the insertion of the module to the connector of the interchangeable module.

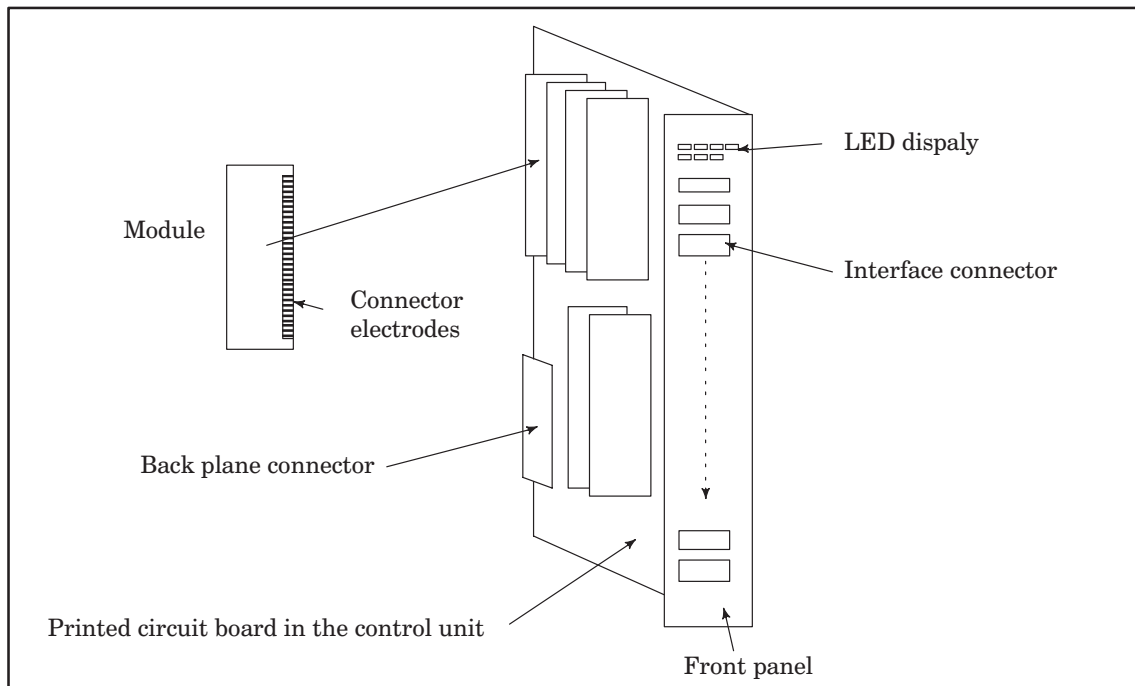

Fig. 1.1.2 Configuration of the Printed Circuit Boards in the CNC Control Unit

### 1.1.3 Configuration of the CRT/MDI unit

The CRT/MDI unit consists of the parts shown in Fig. 1.1.3. The unit is constructed of a CRT display and plastic panel screwed to a metal panel.

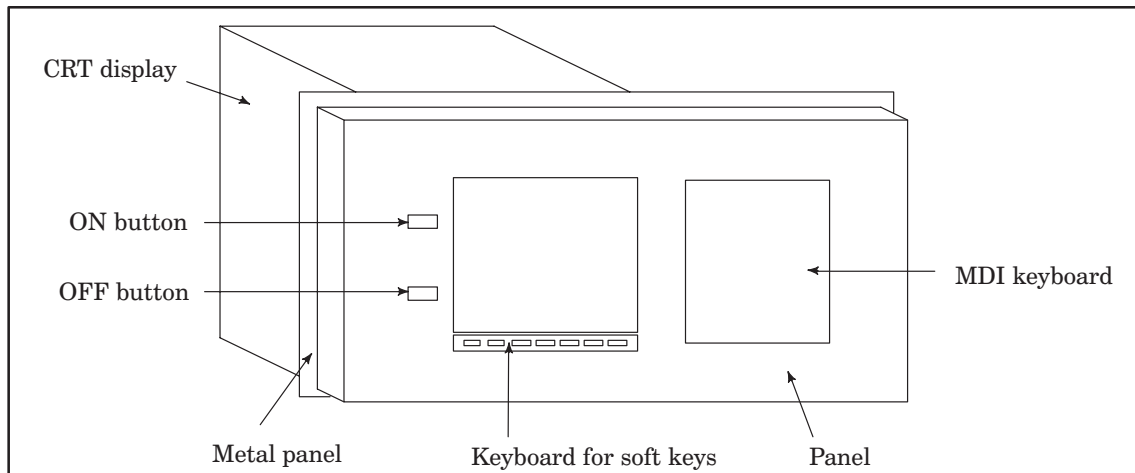
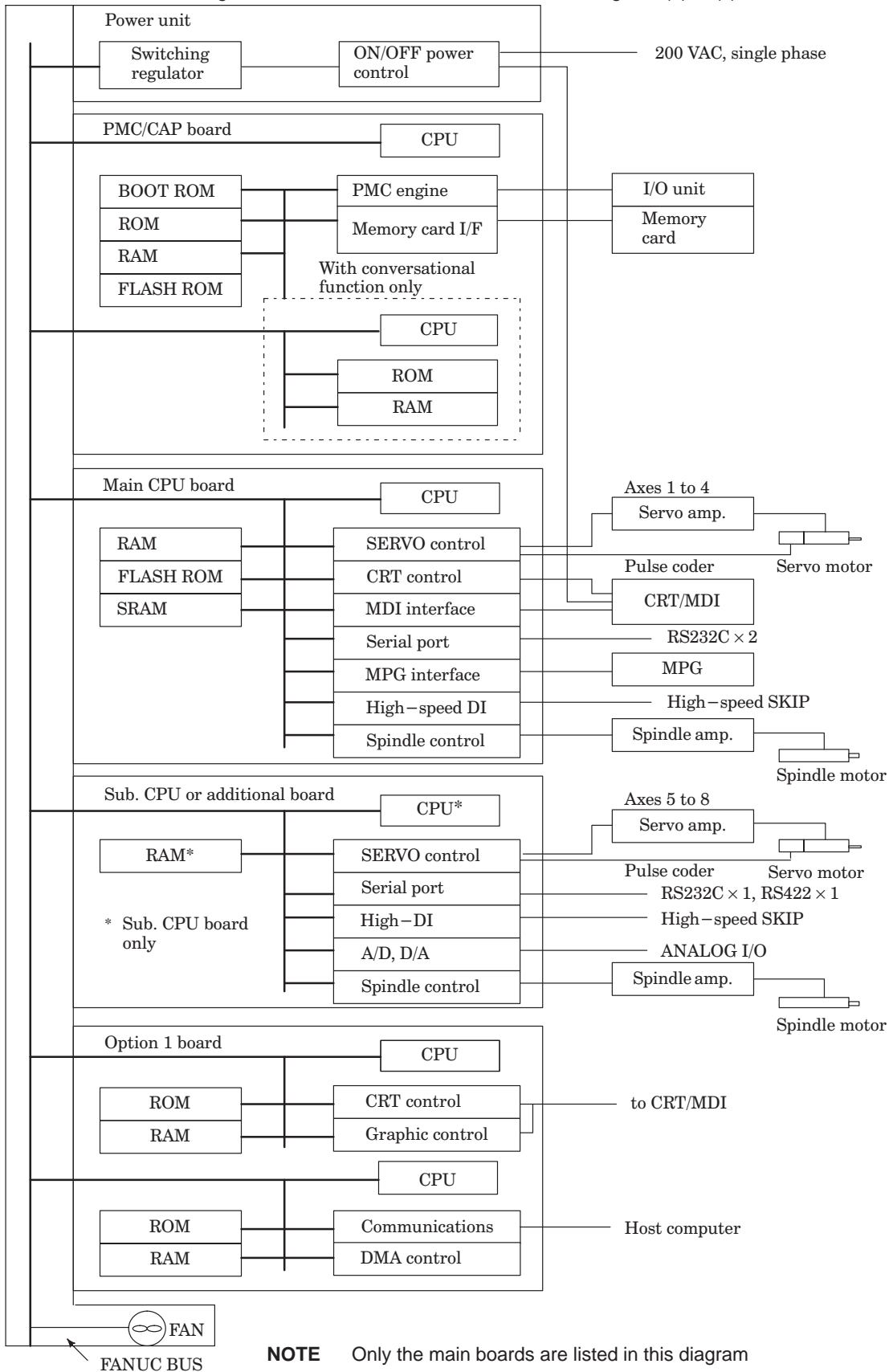

Fig. 1.1.3 CRT/MDI Unit Configuration

### 1.2 Block Diagram for the CNC Control Unit

Series 15-B block diagram for the CNC control unit is described in fig. 1.2 (a) to (c).



**NOTE** Only the main boards are listed in this diagram

**Fig. 1.2 (a) Block Diagram for Series 15-B Standard System**

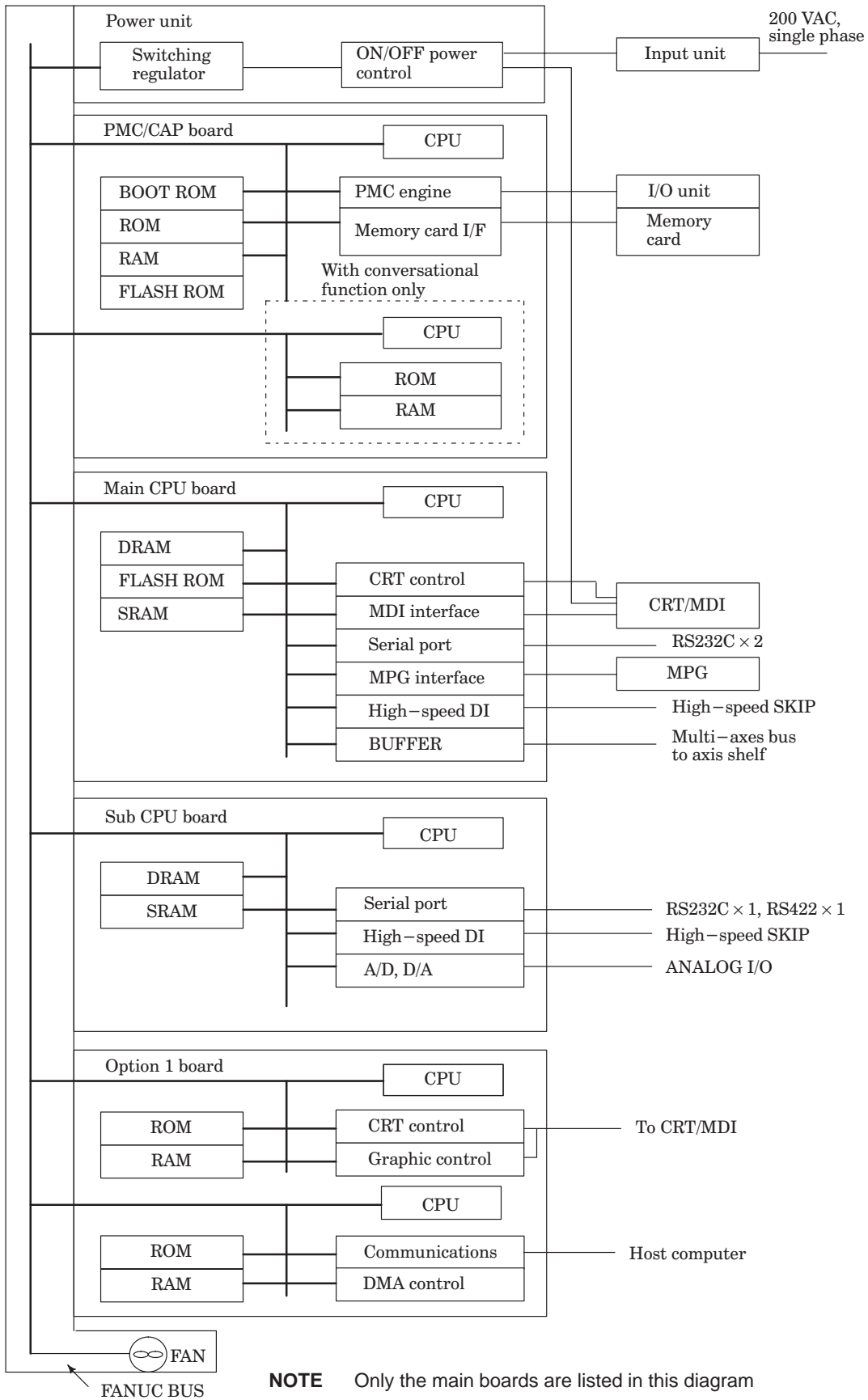

Fig. 1.2 (b) Block Diagram for Series 15-B Multi-axes System (Main Shelf Side)

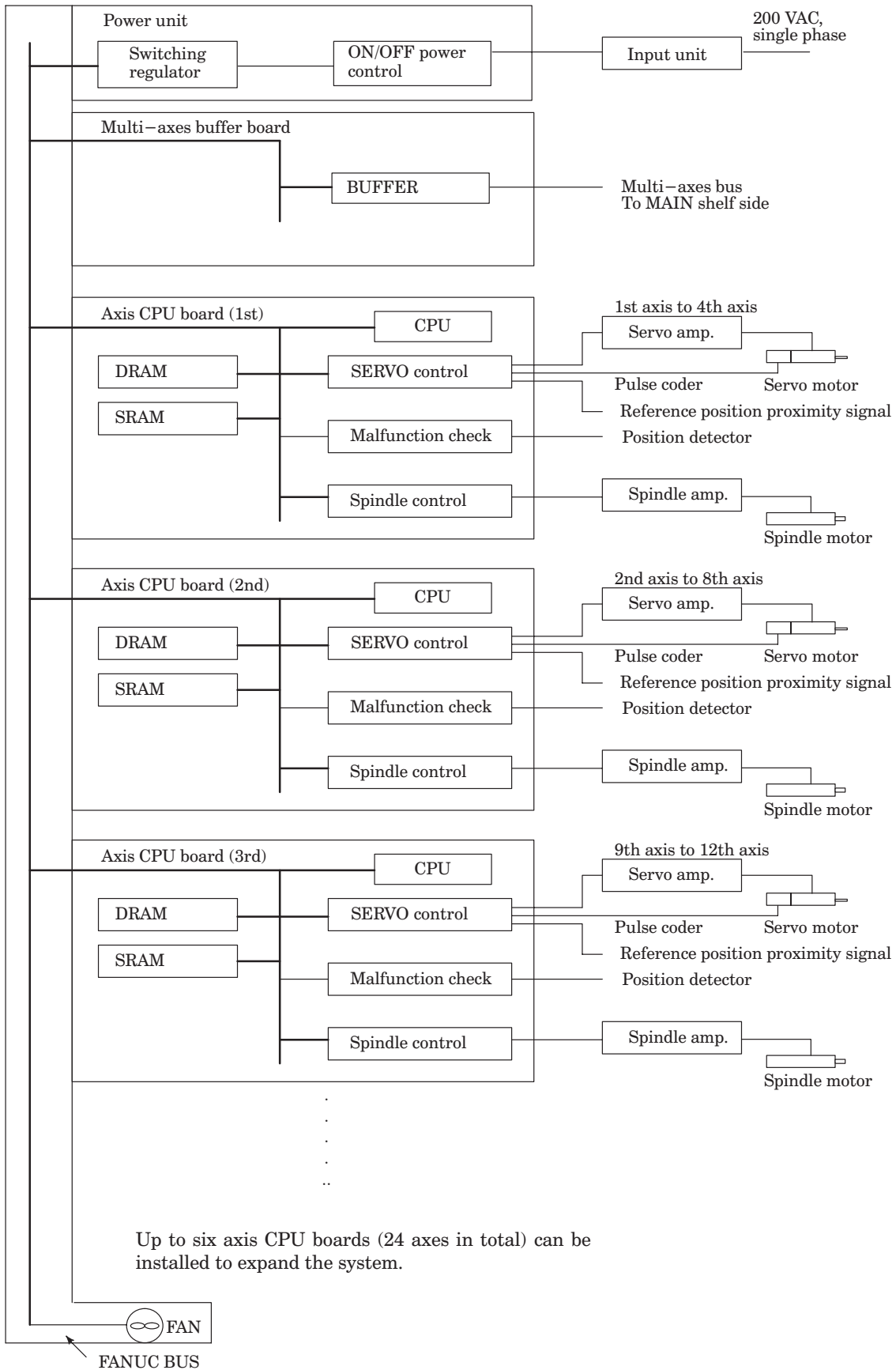

Fig. 1.2 (c) Block Diagram for Series 15-B Multi-axes System (Axis shelf side)

### 1.3 List of the Printed Circuit Boards and Units of Series 15-B

(a) Control unit rack

Control unit rack

Name		Drawing No.	Remarks		
Control unit rack	3 – SLOT	A02B-0162-C001	FANUC name plate	Standard	Without Sub.BUS
	4 – SLOT	A02B-0162-C002			
	6 – SLOT	A02B-0162-C003			
	8 – SLOT	A02B-0162-C004			
	6 – SLOT	A02B-0162-C008		Response to MMC-IV	
	8 – SLOT	A02B-0162-C009			
	3 – SLOT	A02B-0162-C011	GE-Fanuc name plate	Standard	
	4 – SLOT	A02B-0162-C012			
	6 – SLOT	A02B-0162-C013			
	8 – SLOT	A02B-0162-C014			
	6 – SLOT	A02B-0162-C018		Response to MMC-IV	
	8 – SLOT	A02B-0162-C019			
	4 – SLOT	A02B-0162-C022	FANUC name plate	Standard	With Sub.BUS
	6 – SLOT	A02B-0162-C023			
	8 – SLOT	A02B-0162-C024			
	6 – SLOT	A02B-0162-C028		Response to MMC-IV	
	8 – SLOT	A02B-0162-C029			
	4 – SLOT	A02B-0162-C032	GE-Fanuc name plate	Standard	
	6 – SLOT	A02B-0162-C033			
	8 – SLOT	A02B-0162-C034			
6 – SLOT	A02B-0162-C038	Response to MMC-IV			
8 – SLOT	A02B-0162-C039				

Power unit

Name		Drawing No.	Remarks
Power unit	AI	A02B-1212-0471	
	BI	A02B-1212-0531	

## Control unit PCB

Name		Drawing No.	Remarks		Module ID
Main CPU board	Standard Main-B	A16B-2201-0320			71
	High-speed Main-A	A16B-2201-0300			62
	Main C	A16B-3200-0060	Level up		97
	High-speed Max Main-A	A16B-2201-0340	For multiaxis control, synchronous control, and malfunction check		67
PMC board	Without conversational CPU for PMC - NA	A16B-2201-0371 A16B-2201-0391			77
	Without conversational CPU for PMC - NB	A16B-2201-0381 A16B-2201-0811			6B
	Without conversational CPU for PMC - NA	A16B-2201-0390			77 / 6D
	Without conversational CPU for PMC - NB	A16B-2201-0810			7B / 6D
Additional axis board		A16B-2201-0311			63
Axis CPU board		A16B-2201-0360			7A
Buffer board		A16B-2201-0351			68
Sub CPU board	Standard Max Sub-B	A16B-2201-0331	Only for multiaxis control, synchronous control, and malfunction check		73
	High-speed Sub-A	A16B-2201-0310			63
	Sub-C	A16B-2202-0571	Level up		A1
Option 1 board	Graphic+Remote buffer	A16B-2200-0910	Increase of graphic CPU RAM	For 14" CRT, 10" LCD, or 9" graphic	45 / 3F
	Graphic+DNC1	A16B-2200-0911			45 / 3F
	Graphic	A16B-2200-0912			45
	Graphic	A16B-2200-0917	Graphic CPU RAM (standard)		45
	Graphic+Remote buffer	A16B-2200-0915			45 / 3F
	Graphic+Remote buffer	A16B-2200-0918	Increase of graphic CPU RAM	For 9.5" LCD, 8.4" LCD, or MMC-IV	45 / 3F
	Graphic+DNC1	A16B-2200-0916			45 / 3F
	Graphic	A16B-2200-0919			45
	Remote buffer	A16B-2200-0913			3F
	DNC1	A16B-2200-0914			3F
RISC board		A16B-2201-0710			7F
ROM cassette adapter		A20B-2000-0760			74

## Back plane PCB

Name		Drawing No.	Remarks	
Back plane	3-SLOT	A20B-2000-0900	Standard	
	4-SLOT	A20B-2000-0710		
	6-SLOT	A20B-2000-0720		
	8-SLOT	A20B-2000-0730		
	6-SLOT	A20B-2001-0650	Response to MMC-IV	
	8-SLOT	A20B-2001-0660		
	SUB BUS	A20B-1005-0270		



## Module (For main CPU board)

Name		Drawing No.	Remarks
Spindle control module	Serial spindle+ High-speed skip	A20B-2900-0672	
	Analog spindle+ High-speed skip	A20B-2900-0770	
Peripheral module		A20B-2900-0660	
FLASH ROM module	6MB	A20B-2900-0810	
	4MB	A20B-2900-0811	
	2MB	A20B-2900-0812	
DRAM module	8MB	A20B-2900-0650	For MAIN-C
	4MB	A20B-2900-0651	
	2MB	A20B-2900-0800	
	6MB	A20B-2901-0940	
	4MB	A20B-2901-0941	
	2MB	A20B-2901-0942	
High-speed SRAM module		A20B-2900-0641	
SRAM module	2MB	A20B-2900-0682	
	1MB	A20B-2900-0680	
	512KB	A20B-2900-0681	
	256KB	A20B-2900-0700	
	128KB	A20B-2900-0701	
	64KB	A20B-2900-0711	
Servo control module		A20B-2901-0340	Cannot be used for MAIN-C.
		A20B-2902-0180	
Servo interface module		A20B-2900-0830 A20B-2901-0360	
CRT control module		A20B-2900-0691	9" CRT control

## Module (For PMC/conversational board)

Name		Drawing No.	Remarks
PMC CPU module	For PMC-NA	A20B-2900-0780	
	For PMC-NB	A20B-2901-0581	
PMC engine module	For PMC-NA	A20B-2900-0790	
	For PMC-NB	A20B-2901-0660	
DRAM module	2MB	A20B-2900-0653	
	512KB	A20B-2900-0803	
SRAM module	1.25MB	A20B-2901-0400	For PMC-NB only
	512KB	A20B-2901-0402	
Conversational CPU module		A20B-2901-0390	
EPROM module	1MB	A20B-2900-0290	
	768KB	A20B-2900-0291	
	512KB	A20B-2900-0292	

## Module (For PMC/conversational board)

Name		Drawing No.	Remarks
DRAM module	1MB	A20B-2900-0550	
	512KB	A20B-2900-0551	
	128KB	A20B-2900-0555	
SRAM module	512MB	A20B-2900-0541	

## Module (For Sub CPU board, additional axis board, or axis CPU board)

Name		Drawing No.	Remarks
Spindle control module	Analog spindle+ High-speed skip	A20B-2900-0770	
	Serial spindle+ High-speed skip	A20B-2900-0672	For axis CPU
Analog input & Serial communication module		A20B-2900-0721	Serial communication is each one channel of RS-422 or RS-232-C.
Servo control module		A20B-2901-0340	Cannot be used for SUB-C
		A20B-2902-0180	
Servo interface module		A20B-2901-0360 A20B-2900-0830	
DRAM module	2MB	A20B-2900-0800	For SUB-C
	1MB	A20B-2900-0802	
	2MB	A20B-2901-0942	
High-speed SRAM module		A20B-2900-0641	
SRAM module	512KB	A20B-2900-0681	
	256KB	A20B-2900-0700	

## Module (For RISC board)

Name		Drawing No.	Remarks
SRAM module	512KB	A20B-2900-0541	
ROM module	512KB	A20B-2900-0292	

## Module (For option 1 board)

Name		Drawing No.	Remarks
CRT control module	14"CRT	A20B-2901-0370	Standard
	10"LCD 10" PDP	A20B-2901-0372	
	9.5" 8.4" LCD	A20B-2902-0272	
	9"CRT 9"PDP	A20B-2901-0371	
	14"CRT	A20B-2901-0373	MMC-III
	10"LCD	A20B-2901-0375	
	MMC-IV	A20B-2902-0275	MMC-IV
Communication control module		A20B-2900-0361	
Graphic control module		A20B-2900-0310	Standard
		A20B-2900-0311	When MMC-IV or the 9.5" or 8.4" LCD is used
Graphic CPU module		A20B-2900-0350	

## (b) External control unit (except I/O unit)

Name		Drawing N	Remarks
9" CRT/MDI unit	monochrome vertical	A02B-0162-C041	
	monochrome horizontal	A02B-0162-C042	
	color vertical	A02B-0162-C051	
	color horizontal	A02B-0162-C052	
9" small type CRT/MDI unit	monochrome	M	A02B-0162-C101
		T	A02B-0162-C102
9" PDP/MDI unit	monochrome vertical	A02B-0162-C061	
	monochrome horizontal	A02B-0162-C062	
9.5" LCD/MDI unit	color vertical	A02B-0162-C131	
	color horizontal	A02B-0162-C132	
	color vertical	A02B-0162-C141	
	color horizontal	A02B-0162-C142	
10" LCD/MDI unit	color vertical	A02B-0162-C071	
	color horizontal	A02B-0162-C072	
10" PDP/MDI unit	monochrome vertical	A02B-0162-C081	
	monochrome horizontal	A02B-0162-C082	
14" CRT/MDI unit	color vertical	A02B-0162-C091	
	color horizontal	A02B-0162-C092	
	color vertical	A02B-0162-C121	For MMC-IV
	color horizontal	A02B-0162-C122	For MMC-IV
9" separate CRT unit	monochrome	A02B-0162-C043	
	color	A02B-0162-C053	
9" separate PDP unit	monochrome	A02B-0162-C063	
Separate MDI unit		A02B-0162-C111	
Connection unit 1		A02B-1005-0310	DI/DO=96/64
Connection unit 2		A02B-1003-0200	DI/DO=96/64
Operator's panel connection unit	A	DI/DO=64/32	A16B-2200-0661
	B	DI/DO=96/64	A16B-2200-0660
Optical I/O link adapter		A13B-0154-B001	It is used also for serial spindle interface

## (c) I/O Unit-MODEL A

Name		Drawing No.	Remarks					
Basic unit	ABU10A	A03B-0807-J001	It's possible to mount up to 10 modules.					
	ABU10B	A03B-0807-J004						
Basic unit	ABU05A	A03B-0807-J002	It's possible to mount up to 5 modules.					
	ABU05B	A03B-0807-J003						
Interface module	AIF01A	A03B-0807-J011	For slave					
	AIF01B	A03B-0807-J012						
	AIF02C	A03B-0807-J013						
Digital input module		Drawing No.	Type	Point	Voltage	Po-rarity	Resp onse	Connection
*1.When input is Lo level, it will be considered to turn on. (0V common)  *2.When Input is Hi level, it will be considered to turn on. (24V common)	AID32A1	A03B-0807-J101	Non-in slation type DC input	32	DC24V	Both	20ms	Connector A
	AID32B1	A03B-0807-J102		32	DC24V	Both	2ms	Connector A
	AID32H1	A03B-0807-J111		32	DC24V	Both	2ms:8 20ms:8	Connector A
	AID16C	A03B-0807-J103	Inslation type DC input	16	DC24V	*1 NEG	20ms	Terminal block
	AID16D	A03B-0807-J104		16	DC24V	*2 DOS	20ms	Terminal block
	AID16K	A03B-0807-J113		16	DC24V	*1 NEG	2ms	Terminal block
	AID16L	A03B-0807-J114		16	DC24V	*2 POS	2ms	Terminal block
	AID32E1	A03B-0807-J105	Inslation type DC input	32	DC24V	Both	20ms	Connector A
	AID32E2	A03B-0807-J110		32	DC24V	Both	20ms	Connector B
	AID32F1	A03B-0807-J106		32	DC24V	Both	2ms	Connector A
AID32F2	A03B-0807-J109	32		DC24V	Both	2ms	Connector B	
AID16G	A03B-0807-J107	AC input		16	AC100 -115V	ON 30ms OFF 45ms		Terminal block

## I/O Unit-MODEL A

Name		Drawing No.	Remarks					
Digital output module		Drawing No.	Type	point	Voltage	Po- rarity	Resp once	Connection
*3.When turning on, output becomes Lo level. (0V common)  *4.When turning on output becomes Lo level. (24V common)	AOD32A1	A03B-0807-J162	Non - inslation type DC output	32	DC5 -24V	*3 NEG	0.3A	Connection A
	AOD08C	A03B-0807-J151	Inslation type DC output	8	DC12 -24V	*3 NEG	2A	Terminal block
	AOD08D	A03B-0807-J152		8		*4 POS	2A	Terminal block
	AOD16C	A03B-0807-J153		16		*3 NEG	0.5A	Terminal block
	AOD16D	A03B-0807-J154		16		*4 POS	0.5A	Terminal block
	AOD32C1	A03B-0807-J155		32		*3 NEG	0.3A	Connector A
	AOD32D1	A03B-0807-J156		32		*4 POS	0.3A	Connector A
	AOD32D2	A03B-0807-J167		32		*4 POS	0.3A	Connector B
	AOA05E	A03B-0807-J157		AC output		5	AC100 -230V	
	AOA08E	A03B-0807-J158	8			1A		Terminal block
	AOA12F	A03B-0807-J159	12		AC100 -115V			0.5A
	AOR08G	A03B-0807-J160	Relay output	8	AC250V /DC30V		4A	Terminal block
	AOR16G	A03B-0807-J161		16			2A	Terminal block
	AOR16H2	A03B-0807-J165		16		DC30V		2A
	Name		Drawing No.	Remarks				
Analog input module	AAD04A	A03B-0807-J051	Analog input 4 channels					
Analog output module	ADA02A	A03B-0807-J052	Analog output 2 channels					
High-speed counter module	ACT01A	A03B-0807-J052	Pulse input 1 channel					

## 2. MAINTENANCE EQUIPMENT

### 2.1 Maintenance Equipment

The following equipment is recommended.

#### 1) Measuring instruments

Table 2.1 Measuring Instruments for Maintenance

Instrument	Requirements	Usage
AC voltmeter	Capable of measuring AC powersupply voltages within a tolerance of $\pm 2\%$ .	Measurement of AC powersupply voltage
DC voltmeter	Capable of measuring DC voltages of 10V and 30V within a tolerance of $\pm 2\%$ (digital voltmeter may be required).	Measurement of DC powersupply voltage

#### 2) Tools

Phillips screwdriver : large, medium and small

Standard screwdriver : large, medium and small

### 2.2 Main Spare Parts

The following replacement parts should be available:

– Fuses (see 8.1)

## 3. TROUBLESHOOTING AND ACTION TO BE TAKEN

### 3.1 Procedures for Troubleshooting

The procedures for troubleshooting are classified according to the status of the disabled NC unit as follows. Take the appropriate corrective action as listed below.

- |  |                 |
|--|-----------------|
| (1) Action to be taken when a system alarm is displayed                              | See Item 3.2.1. |
| (2) Action to be taken when an error code is displayed                               | See Item 3.2.2. |
| (3) An alarm LED lights:   | See Item 3.2.3. |
| (4) The machine cannot be operated in the jog mode:                                  | See Item 3.2.4. |
| (5) The machine cannot be operated by the manual pulse generator:                    | See Item 3.2.5. |
| (6) The spindle cannot be operated in the synchronous feed mode:                     | See Item 3.2.6. |
| (7) The machine cannot be operated in the automatic mode:                            | See Item 3.2.7. |
| (8) The input/output devices of the reader/punch interface do not operate correctly: | See Item 3.2.8. |
| (9) The machine does not return to the correct reference position:                   | See Item 3.2.9. |

Items to be checked when a problem occurs
---

Check the following items and report the results when contacting your FANUC Service Center.

- (1) Nature of the problem
  - i) Mode
  - ii) Operation or program employed and the tool offset value when the problem occurs
  - iii) Alarm message
  - iv) Frequency with which the problem occurs
  - v) The magnitude of a positional error, if any
  - vi) The position at which the problem occurred
  - vii) If a system alarm occurs, which LEDs on the PCB are on
- (2) Miscellaneous information
  - i) Series and edition of the software displayed on the screen when the power is turned on
  - ii) Description of the system parameter (Check the system parameter setting of the machine with the parameter list supplied with to the unit.)

### 3.2 Problems and Corrective Measures

#### 3.2.1 System alarm

If the CNC system encounters a serious failure in the hardware or software and the system decides it impossible to continue operation, it stops normal operation and enters the system alarm state. In this state, the system automatically analyzes possible causes of the failure and displays the result on the screen. In most cases, it is not possible for users to restore the system. Check the items described in 3.1 and contact your FANUC Service Center.

All information displayed on the screen is stored in the memory in the CNC system. Therefore, it is possible to refer to the information on the system history screen after the system is restored and the power is turned on again.

For details on the system alarms and how to display the system history screen, refer to Appendixes 1 and 2.

### 3.2.2 Action to be taken when an error code is displayed

If the CNC system detects an error, it displays the corresponding error code and alarm message on the screen. The error codes and alarm messages are listed in the Operator's Manual (Programming). For an explanation of servo alarms, refer to the relevant maintenance manual. Each servo alarm is described, together with the corresponding corrective action.

The following covers important alarms and the actions to be taken.

#### (1) PS200 PULSE CODER SYNCHRONOUS ERROR

While returning to the reference position, either a one-rotation signal is not sent from the pulse coder or the signal is sent but the motion is too slow.

When a pulse coder is employed, the reference counter is synchronized with the one-rotation signal the first time the machine returns to the reference position after the power is turned on or an emergency stop is reset. In this synchronization, the following conditions must be met so that the same edge of the one-rotation signal can be detected.

(A) The positional deviation (diagnosis function No. 3000) must be at least 128.

(B) One or more one-rotation signals must be sent after the positional deviation (diagnosis function No. 3000) has been at least 128 (but before the deceleration dog is released again).

The one-rotation signal is not used when the machine returns to the reference position the second or subsequent time. Thus, this alarm does not occur after the machine has returned to reference position the first time.

Item	Possible cause of the problem	How to check the cause	Action to take
1	The feedrate is too slow.	Return the machine to the reference position under the same system conditions system as when the alarm occurred. Then, check the positional deviation (diagnostic data, parameter No.3000) using the self-diagnosis function and check that the deviation exceeds 128. In particular, carefully check the deviation when the machine returns to the reference position from the position at which the deceleration dog is pressed.	Increase the feedrate. When the position gain is $30\text{sec}^{-1}$ , the feedrate should be 300 mm/min or more.
2	The position at which the machine starts returning to the reference position is too close to the reference position.	Check the distance between the start position and the reference position.	Use a start position whose distance from the reference position is equivalent to two or more motor rotations.
3	The power supply voltage to the pulse coder is too low.	Check that the voltage through the pulse coder is 4.75V or above. <div style="border: 1px solid black; padding: 5px; margin: 5px 0;">           To check the voltage through the pulse coder, remove the cover of the servo motor and measure the voltage between the positive and negative terminals on the printed circuit board of the pulse coder or between the land connected to the +5 V and the 0 V lines.         </div>	The voltage drop through the cables must be 0.2V or less in total in both the 5-V line and 0-V line.
4	The pulse coder is defective	Replace the pulse coder and check that the error is eliminated.	Replace the pulse coder.
5	The main CPU board or sub board is defective.	Replace the printed circuit board to which the erroneous axis is connected, and check that the error is eliminated.	Replace the pulse coder.



## (2) OT 007 + OVERTRAVEL (HARD)

## OT 008 – OVERTRAVEL (HARD)

The above alarm message is displayed on the screen if the machine reaches the end of the stroke. When this alarm occurs in the automatic mode, the machine stops motion along all axes. In the manual mode, only motion along the axis on which the alarm occurred stops.

Each axis of the machine is equipped with two limit switches (LS1 and LS2) as shown below along each direction, and they stop the movable parts of the machine.

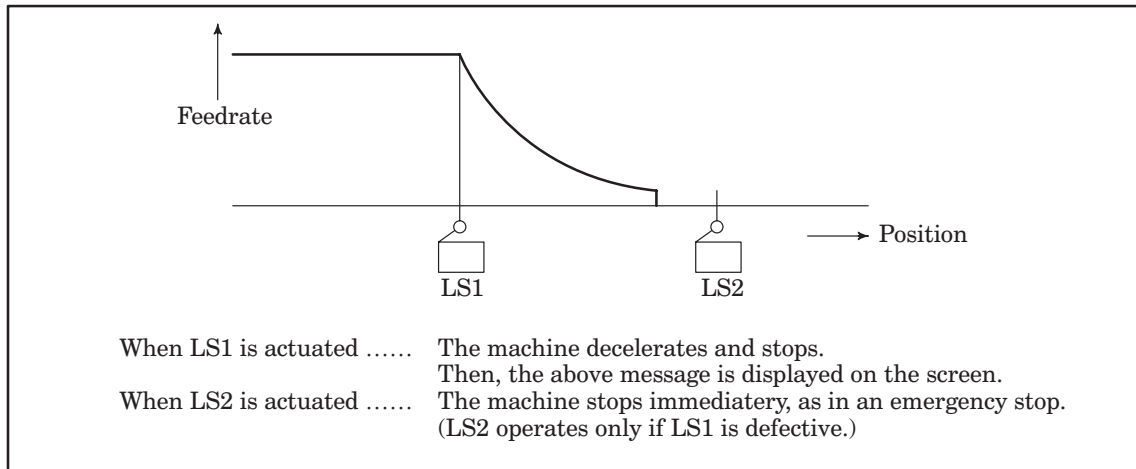

(Causes and counter measures)

1. The wrong reference position was specified in setting the coordinate system.  
→ Modify the program.
2. The program has bugs in it. → Modify the program.

(How to reset the error)

(a) When only LS1 is actuated:

Move the machine manually in the opposite direction in the jog, step, or handle mode and disengage it from the limit switch. Then, press the RESET button on the MDI panel.

**NOTE** It is only possible to move the machine toward the normal operating area.

(b) When both LS1 and LS2 are actuated:

1. Press on the 2ND LS release button.
2. Follow the same step as above for resetting LS1.

**NOTE** For a machine on which LS1 does not operate when LS2 is actuated, the machine can be moved manually in both directions. Take care not to move the machine in the wrong direction.

(3) OT 001 + OVERTRAVEL (SOFT1) } Stored stroke limit alarms  
OT 006 – OVERTRAVEL (SOFT3) }

The above alarm message is displayed on the screen when the machine reaches the stored stroke limit. When this alarm occurs in the automatic mode, the machine stops moving along all axes. In the manual mode, only motion along the axis on which the alarm occurred stops.

(Causes)

- (a) The program has bugs in it.
- (b) The wrong stroke limit was stored.

(Check)

The position of the machine in the machine coordinate system relative to the reference position can be checked on the position display screen.

(Counter measures)

- (a) Modify the program.
- (b) Store a correct stroke limit.

(How to reset the error)

- (a) The machine can be moved only toward the normal operating ranges.
- (b) When the machine has stopped in the restricted zone and cannot escape it, press the emergency stop button to reset the alarm. Then, specify G23 on the MDI panel to disable the stored stroke limit function and move the machine in the jog mode.

(4) SV 013 IMPROPER V-READY OFF

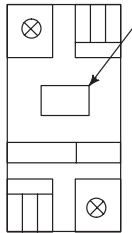
Item	Possible cause of the problem	How to check the cause	Action to take
1	Fault analysis	Check if green LED DRDY lights in servo amplifier PCB.	Proceed to item 2 when LED DRDY lights. Proceed to item 8 when it does not light.
2	Fault analysis	Check if alarm LED lights in servo amplifier PCB.	If this LED lights, locate and eliminate the cause of the alarm ( see the following 1st, A-D).prossees to item 3, when this LED does not light.
3	Fault analysis	Check if electromagnetic contractor MCC is turned on in servo amplifier.	Proceed to item 8 when MCC is energized. Proceed to item 4 when it is not energized.
4	Fault analysis	Check if 100V is applied between terminals (3) and (4) of terminal board T1 of servo amplifier.	Proceed to item 9 when power is applied. Proceed to item 5 if not applied.
5	Signals from machine tool	Check 100V power supply Check if emergency stop signal is sent from machine tool or if the machine tool is ready for operation.	Restore to normal conditions.
6	Trouble in servo amplifier	Servo amplifier PCB or MCC is defective.	Replace.
7	Poor contact	Poor contact between servo amplifier and main CPU or option 2 board, or a problem in master PCB.	Replace.
8	Poor contact	Poor contact inside servo amplifier or a trouble in servo amplifier PCB.	Replace.
9	No fuse breaker in turned off.	Check the no fuse breaker button on/off state	If it is not off, proceed to item 6.
10	No fuse breaker functions	<p>The operating conditions as illustrated below.</p>  <p>While the motor operates normally, this lever is at upper position and the ON indication can be seen. If the circuit breaker trips, the lever moves to the lower position and the OFF indication appears. To reset the breaker turn off the three-phase power supply, and move the lever to the upper position.</p>	Reset the no fuse breaker after turning off the power supply. ( if the no fuse breaker trips immediately then wait for about 10 minutes before attempting another breaker reset.)
11	Diode module, surge absorber (TNR) or other parts are faulty in servo amplifier.	No fuse breaker functions when power supply is turned on after the corrective action in item 1.	Replace diode module DS or surge absorber (ZNR) of servo amplifier.

- (5) SV 008 EXCESS ERROR (STOP)  
 SV 009 EXCESS ERROR (MOVING)  
 Excessive positional deviation alarm

Item	Possible cause of the problem	How to check the cause	Action to take
1	An incorrect positional deviation is specified.	Check that the settings in parameter Nos. 1828 to 1830 conform to the parameter list supplied with the NC unit.	Set the parameters to the correct settings.
2	Overshoot	When the current necessary to accelerate or decelerate the motor in accordance with the the acceleration/deceleration of the NC unit does not pass through the motor, the amount of error in the positioning control circuit increases for some time.	Increase the rapid traverse time constant of the NC unit. (Specify it on the control unit.)
3	The input power supply voltage is too low.	Measure the input power supply voltage and check that it is within the range of +10% to -15%.	Set the proper voltage on the input tap of the power transformer for the servo.
4	Incorrect cable connection	Check that cables such as the motor power line are connected correctly.	Connect the cables correctly.
5	The main CPU board or sub board is defective, or the printed circuit board of the servo amplifier is defective.	If a spare board is available, replace defective board and check that the alarm does not occur. When using a new board, ensure that it is correctly adjusted and set.	Replace the printed circuit board.

### 3.2.3 Lighting of alarm LEDs on PCBs

If an alarm condition occurs, an alarm message is usually displayed on the CRT screen. The state of the PCB when the alarm occurred is indicated by the LEDs on the front panel of each control unit PCBs, as shown below. When a system alarm occurs, the alarm message displayed on the screen, together with the LED indications on each PCB, help you to determine the cause. Record the LED indications for each PCB to enable rapid recovery of the system.

For the descriptions of LED lamps on each printed circuit board, see Chapter 7.

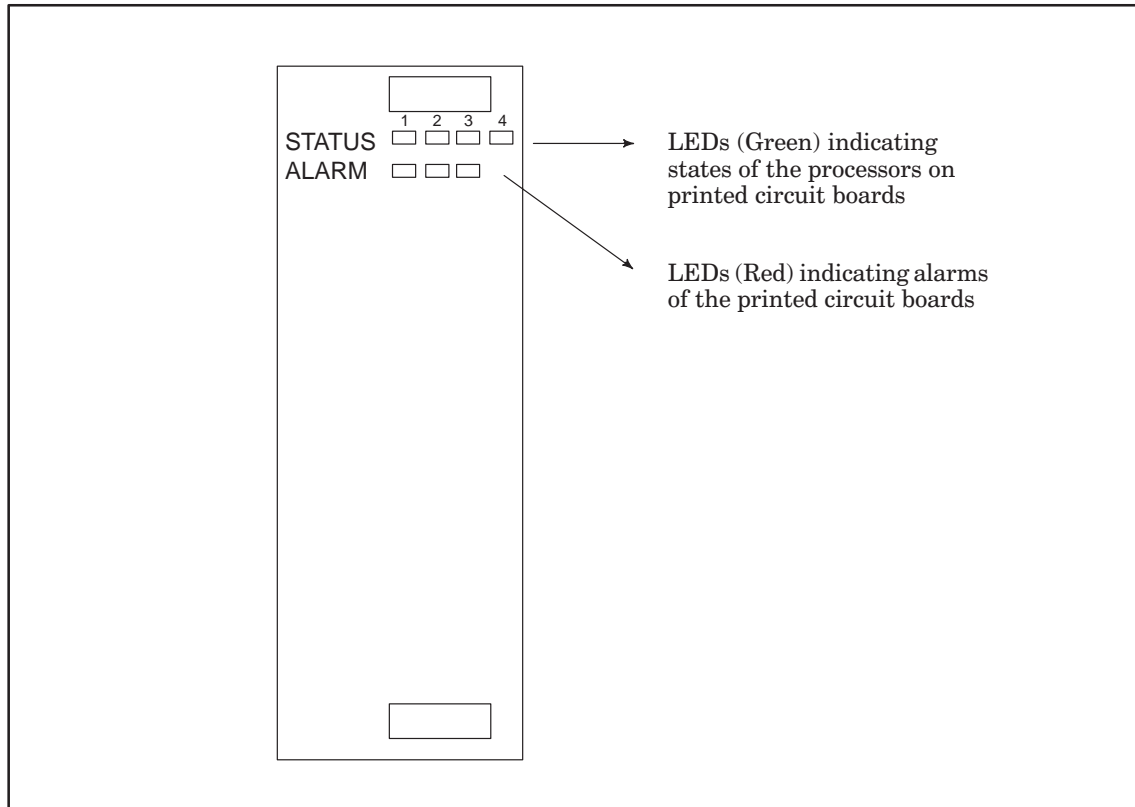

Fig. 3.2.3 LED Display for the Printed Circuit Boards in the Control Unit

## 3.2.4 The machine cannot be operated in the jog mode.

Item	Possible cause of the problem	How to check the cause	Action to take
1	Failure analysis	Check whether the position display changes with the display lock (DLK) turned off.	
		1. The position display changes but the machine cannot be moved.	See Item 2.
		2. Neither the position display changes nor can the machine be moved.	See Item 5.
2	The machine lock (MLK) is on.	Check the MLK signal in the DGN data.	
3	The servo off signal is on.	Check the servo off signal in the DGN data. Check parameter No. 1802.	
4	Malfunction in the servo system	Refer to the "FANUC AC Servo Unit Maintenance Manual."	
5	The interlock signal is on. The JOG override is 0%.	Check DGN data (parameter No. 1000).	
6	The mode signal is not input.	Check that JOG or J + H is displayed for the status.	
7	The feed axis direction signal is not input.	Check the DGN data to see if the feed axis direction signal is input. <b>Note</b> When an axis command is input before the jog mode is selected, movement along the specified axis will not start. To start the movement, cancel the axis command and then input it again.	
8	An improper jog feedrate is specified.	Check parameter No. 1423. If the machine cannot be operated at rapid traverse, check the rapid traverse feedrate in parameters No. 1420 and thereafter.	
9	External reset (ERS) is on. Reset and rewind (RRW) is on.	Check that RSET is displayed for the status.	Check the connection.
10	Reference position return (ZRN) is on.	Check that REF is displayed for the status.	Check the connection.

**3.2.5 The machine cannot be operated by the manual pulse generator.**

Item	Possible cause of the problem	How to check the cause	Action to take
1	Failure analysis	Check whether the position display changes when the display lock (DLK) is off.	
		1. The position display changes but the machine cannot be moved.	See Item 2.
		2. Neither the position display changes nor can the machine be moved.	See Item 5.
2	The machine lock (MLK) is on.	Check the DGN data.	
3	The servo off signal is on.	Check the DGN data. Check parameter No. 1802.	
4	Malfunction in the servo system	Refer to the "FANUC AC Servo Unit Maintenance Manual."	
5	The interlock signal is on. The JOG override is 0%.	Check the DGN data. (parameter No. 1000).	
6	The mode signal is not input.	Check that HND or J + H is displayed for the status.	
7	The feed axis selection signal is not input.	Check the DGN data to see if the feed axis selection signal is input.	
8	External reset (ERS) is on. Reset and rewind (RRW) is on.	Check that RSET is displayed for the status.	
9	Reference position return (ZRN) is on.	Check that REF is displayed for the status.	
10	The manual pulse generator is defective. The cables are defective.		
11	Correct options are not added.	Check the options with the data sheet.	

**3.2.6 The spindle cannot be operated in the synchronous feed mode.**

Item	Possible cause of the problem	How to check the cause	Action to take
1	Incorrect cable connection	Check the connection between the NC unit and the position coder.	
2	The spindle speed is incorrect.	Check the spindle speed on the screen. Check the DGN data. (parameter No. 1000).	
3	The position coder is defective.		Replace the position coder.
4	The main CPU board is defective.		Replace the main CPU board.

## 3.2.7 The machine cannot be operated in the automatic mode.

Item	Possible cause of the problem	How to check the cause	Action to take
1	Failure analysis	Turn the start button on and off in the automatic mode (T, D, or MEM).	
		1. The automatic operation startup (STL) lamp does not light.	See Item 2.
		2. The automatic operation startup (STL) lamp lights but the spindle does not move.	See Item 6.
2	The mode signal is not input.	Check that TAPE, MEM, or MDI is displayed for the status.	
3	The start signal is not input.	Check the start signal in the DGN data.	
4	Automatic operation hold signal (*SP)	Check that HOLD is displayed for the status.	
5	A reset signal is input.	Check that RSET is displayed for the status indication on the screen. Check the DGN data (parameter No. 1000).	
6	<ol style="list-style-type: none"> <li>1. The override is 0%.</li> <li>2. Start lock and interlock are on.</li> <li>3. The machine is making a position check.</li> <li>4. The machine is waiting for a rotation signal to spindle 1 in thread cutting.</li> <li>5. The machine is waiting for the spindle to rotate in the feed-per-rotation operation.</li> <li>6. The machine is waiting for the spindle speed arrival signal.</li> <li>7. The machine is reading data from the tape reader.</li> </ol>	Check the DGN data (parameter No. 1000 and 1001).	

**3.2.8 The input/output unit of the reader/punch interface do not operate correctly.**

Item	Possible cause of the problem	How to check the cause	Action to take
1	Failure analysis	The machine cannot punch or read. PUNCH or READ is not displayed at the bottom of the screen during the above operation.	Check the procedure for the operation again, then see Item 2.
		The machine cannot punch or read. "PUNCH" or "READ" is displayed at the bottom of the screen during the above operation.	See Item 5.
		An alarm occurred.	See Item 3.2.
2	The reset signal is input.	Check the DGN data (parameter No. 1000). Check that RSET is displayed for the status.	
3	The mode signal is not input.	Check the DGN data (parameter No. 003) to see if either the EDT mode or MEM mode is set to 1.	
4	Correct options are not added.	Check the options with the data sheet.	
5	Improper setup	Check that correct input/output unit are selected in the setup procedure. (This can be checked by referring to parameter Nos. 20 and thereafter.)	
6	An improper baud rate is specified.	Check parameter Nos. 5001 and thereafter to see if the correct values for the following items are specified for each input/output unit selected in the setup procedure. 1. Baud rate 2. Stop bit 3. Whether the control code is used	
7	Operational error (improper operation) of the input/output unit	Check the operation by referring to the Operation Manual for the input/output unit.	
8	Incorrect cable connection	Check that the connection and wiring of the cables is correct. (The signal cables must be connected according to the specifications established between the machine tool builder and the input/output unit manufacturers.)	
9	The main CPU board or sub board is defective.		Replace the printed circuit board.



**3.2.9 The machine does not return to the correct reference position.**

(1) The position has deviated by one grid.

Item	Possible cause of the problem	How to check the cause	Action to take
1	The position of the deceleration dog is not correct.	While moving the machine from the reference position toward the deceleration dog, monitor the deceleration signal using the diagnosis function, and read the position data on the NC unit to find out the distance between the reference position and the deceleration dog.	The distance from when the machine separates from the deceleration dog until it reaches the reference position must be set to about half the distance moved by one revolution of the motor (or $1/2 \lambda$ for Resolver or Inductosyn).
2	The deceleration dog is too short.	Determine the length of the deceleration dog using the above procedure.	Refer to the Connection Manual and change the dog to one having the required length.
3	The switch for the reference position approach signal is not installed at the proper position.	While moving the machine from the reference position toward the switch for the reference position approach signal, monitor the reference position approach signal using the diagnosis function. Read the position data on the NC unit to determine the distance between the reference position and the switch for the reference position approach signal.	The distance between the reference position and the switch for the reference position approach signal must be set to about half the grid spacing (one-half the distance moved by one revolution of the motor for the pulse coder, or $1/2 \lambda$ for Resolver or Inductosyn).

(2) The deviation of the return position is random.

Item	Possible cause of the problem	How to check the cause	Action to take
1	Noise	Check that shield of each cable is grounded. Check that a spark killer is attached to the solenoid coil. Check that the cable for the pulse coder is not routed with a power cable.	Ground the cable shield. Attach a spark killer. Separate the cables.
2	The power supply voltage to the pulse coder is too low.	Check that the voltage through the pulse coder is 4.75 V or more. (To check the voltage through the pulse coder, remove the cover of the servo motor and measure the voltage between the positive and negative terminals on the printed circuit board of the pulse coder or between the +5 V terminal and the 0 V diagnostic land.)	The total voltage drop through the cables must be 0.2 V or less in both the 5-V line and 0-V line.
3	The coupling between the servo motor and the machine is loose.	Put a marking on the motor shaft and check how the machine position corresponds to the motor rotation.	Tighten the coupling.
4	The pulse coder is defective.	Replace the pulse coder and check that the error is eliminated.	
5	The main CPU board or sub board is defective.	Replace the printed circuit board and check that the error is eliminated.	

(3) The deviation of the return position is very small.

Item	Possible cause of the problem	How to check the cause	Action to take
1	Momentary cable disconnection Improper connection of connectors	Check that the cable connectors are clamped and fixed securely. Check the soldering of each connector again. Check the cables are not disconnected, particularly at the bent portions.	Correct any improper cable connection.
2	The Main CPU board, sub CPU board, or additional axis board is defective, or servo amplifier is defective.	Specify 0 for bit 7 of parameter No. 1800 to suppress drift compensation, and check the positional deviation using the diagnosis function (DGN data in parameter Nos. 3000 and thereafter). The variation of the offset results in positional deviation and variation when the machine stops moving. Replace the main CPU or sub board, or the printed circuit board of the servo amplifier.	Replace the axis control printed circuit board or the printed circuit board of the servo amplifier.

How to check the reference position return motion and the position of the deceleration dog

(1) Set each parameter according to the table below.

For parameter No. 1850, set the grid deviation to 0 at the beginning.

Parameter No.	Description
1400	Sets whether manual rapid traverse is effective without returning the machine to the reference position.
1006	Direction of reference position return
1816	Sets the capacity of the reference counter for the X and Z axes in that order.
1005	Sets whether the reference position return function is effective, and sets how the machine is returned.
1850	Sets the grid deviation for the X and Z axes in that order.
1425	Sets the low feedrate (FL) in the reference position return motion.
1240 A	Sets the coordinates of the reference position in the machine coordinate system.
1024	Sets the FM feedrate for reference position return with the magnetic switch.

(2) Return the machine to the reference position and check that the motion is normal.

If the reference position needs to be adjusted, follow the procedure below.

- (i) For the grid method: The reference position can be adjusted by changing the grid deviation (parameter No. 1580). If the reference position needs to be moved by the distance moved by one rotation of the position detector (pulse coder or Resolver), also move the deceleration dog.
  - (ii) For the magnetic switch method: Adjust the position of the proximity switch.
- (3) Check the position of the deceleration dog. (Only when the grid method is used)
- (i) Return the machine to the reference position.
  - (ii) Note down the displayed position of the machine when at the reference position.
  - (iii) While checking the deceleration dog signal (\*DECX or \*DECZ) using the diagnosis function, move the machine at low speed from the reference position toward the dog until this signal turns on.
  - (iv) From the results obtained in (ii) and (iii) above, calculate the distance from the reference position to the position at which the deceleration dog signal turns on. Adjust the position of the deceleration dog so that this distance is about half the distance moved by one rotation of the position detector.

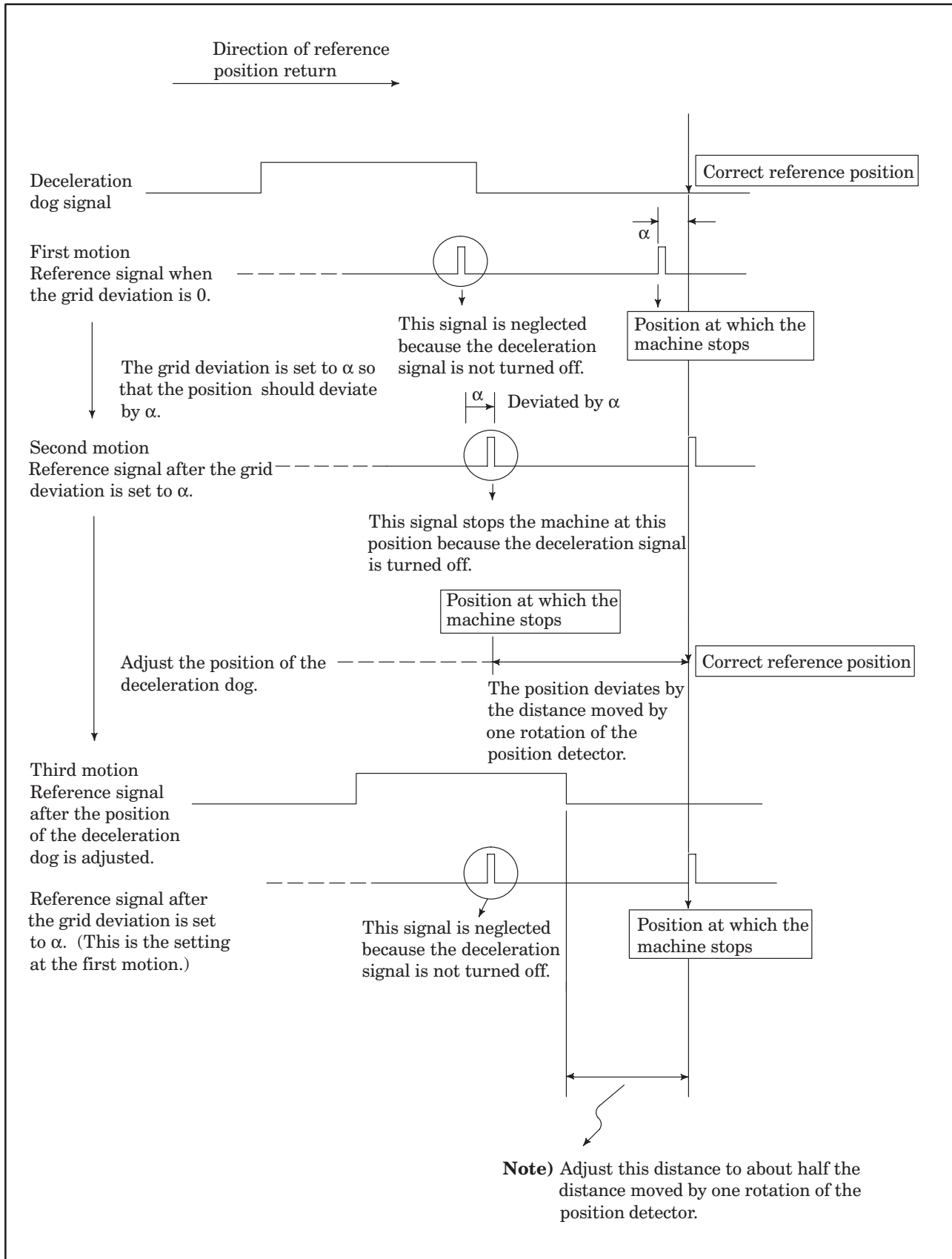

### 3.3 Displaying Conditions Using the Self-diagnosis Function

To quickly determine a breakdown cause the following should be done.

First, it has to be determined whether the breakdown occurred in the NC internal section, or the PMC, or on the machine tool side.

There are times when it appears that a breakdown has occurred even when a breakdown has not actually occurred. For example, when the machinery ceases to operate because the control unit is waiting for an external machine tool signal.

In this case, the condition of the interface between the CNC and PMC, or between the CNC and the machinery, and the conditions within the CNC needs to be investigated.

The explanation on displaying the breakdown condition of the CNC using the self-diagnostics function is shown below.

The following is an example of the five soft keys on 9" CRT/MDI unit. For a unit having 10 soft keys, such as a 14" CRT/MDI unit, the operation is basically the same. For general key operations, refer to the Operator's Manual.

The following shows the five soft keys on a 9" CRT/MDI unit.

POSITION	PROGRAM	OFFSET	PRG-CHK	CHAPTER	+
----------	---------	--------	---------	---------	---

The names of the soft keys in the frames are displayed on the bottom line of the screen.

The + sign in the rightmost frame indicates that there are other soft keys which do not fit on the screen.

#### 3.3.1 Diagnosis function for the interface with machine tools

The PMC sits between the CNC and machine tool and controls the logical relations for signals between them. Because the PMC actually exists as a separate internal function in the NC control unit, the CNC interface signals cannot be considered physical interface signals with the machine tool, that is DI/DO electric signals.

By using the self-diagnostics function, the logic state of each interface signal in the NC control unit can be displayed. Signals F, G, X and Y indicated in Fig. 3.3.1 can be displayed.

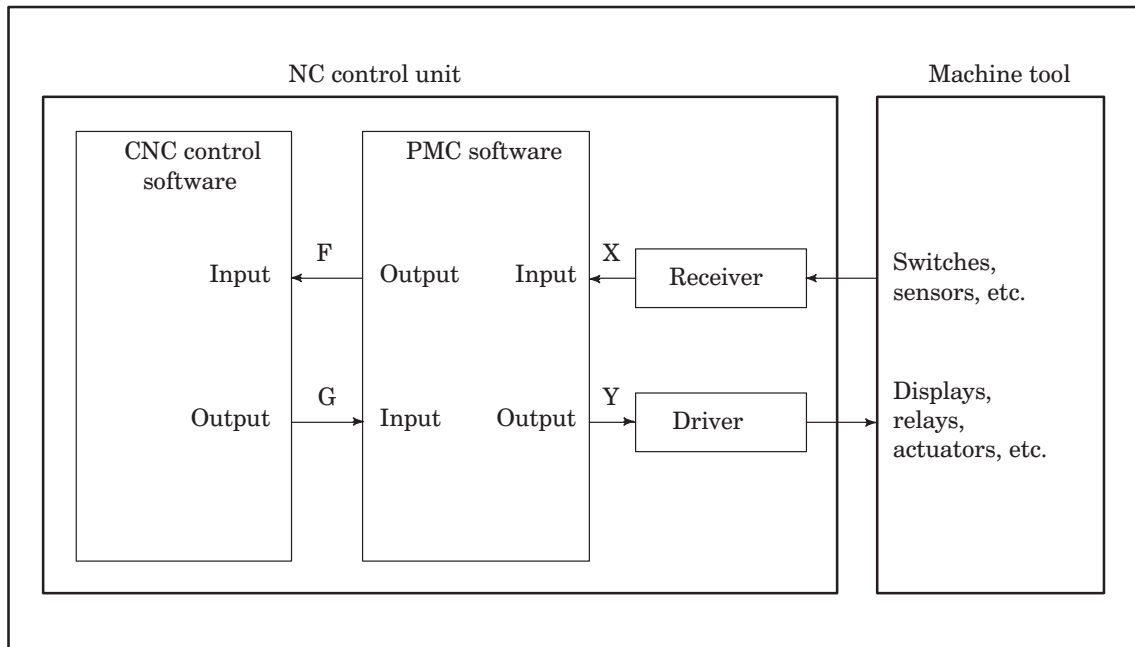

Fig. 3.3.1 Interface Signals that can be Displayed Using the Self-Diagnostics Function

For signal interfaces between the CNC and PMC, see Appendix 3. For details of each signal, refer to the following manuals:

FANUC Series 15-MODEL B Connection Manual (BMI Interface) B-62073E-1

Displaying the status of the signals which interface with the machine

- (a) Press the **CNC/PMC** key on the keyboard. The soft keys for the PMC basic menu appear.

PCMDI	PCLAD	PCDGN	PCPRM		-ETC-
-------	-------	-------	-------	--	-------

- (b) Press the **PCDGN** soft key. The PMC diagnostic function screen appears.

SEARCH	1 BYTE	M.SRCH	TRACE	TITLE	-ETC-
--------	--------	--------	-------	-------	-------

- (c) Enter the address at which data is to be displayed from the keyboard and press the **SEARCH** soft key. The first 10-bytes of data from the specified address are displayed with the bit pattern on the screen.

**Example** X 1 0 0 SEARCH

- (d) Repeat the operation in (c) to display data at another address. Press the **↑** or **↓** key to display the previous or following address.
- (e) Press the **CNC/PMC** key to display the CNC screen.

**NOTE** The procedure above can also be used to display or modify the status of the PMC internal relays in addition to the status of the F, G, X, and Y signals. For details, refer to the following manual:

FANUC PMC-N/NA Programming Manual (Ladder language) B-61013E

FANUC PMC-NB Programming Manual (Ladder language) B-61863E

### 3.3.2 Function to display the CNC internal status

This function displays the simple internal status of CNC software. Specify the DIAGNOSIS screen on the SERVICE function menu to display the status.

When the machine stops moving along an axis during automatic operation, this function can be used to check whether the machined stopped because of a dwell command or position check, or because the interlock signal was set high.

If an alarm related to a servo amplifier or serial pulse coder occurs, this function can also be used to check the details of the error in addition to the displayed error message.

Displaying the CNC internal status

- (a) Press the function menu key (leftmost soft key) several times until the following function selection soft keys appear.

SETTING	SERVICE	MESSAGE		CHAPTER	+
---------	---------	---------	--	---------	---

- (b) Press the **SERVICE** key to display the maintenance screen. When diagnostic data is not displayed on the maintenance screen (when DIAGNOSIS is not displayed at top left of the screen), press the **SERVICE** key several times until diagnostic data appears.

- (c) Scroll the screen using the **↑** or **↓** key or enter the number of the diagnostic data to be displayed from the keyboard, then press the **INP-NO.** key.

The soft keys automatically change to the following keys when a data number is entered.

				INP-NO.	+
--	--	--	--	---------	---

**Example** 1 0 0 0 INP-NO.

## (1) Displaying the status of the PMC interface signals

The status of the interface signals (F and G) between the PMC and CNC can be displayed using the procedure described in Section 3.3.1. The status can also be displayed as the CNC internal status. The following table lists the correspondence between the numbers of this diagnostic data and address numbers (F000 and after and G000 and after) in Section 3.3.1.

	Output from the CNC (G000 and after)	Input to the CNC (F000 and after)
For the BMI interface	Diagnostic numbers 0 and after	Diagnostic numbers 200 and after
For the FS3/6 interface	Diagnostic numbers 400 and after	Diagnostic numbers 500 and after

For example, data passed to the PMC through address G010 by the CNC is displayed as diagnostic data with number 10 (for the BMI interface) or number 410 (for the FS3/6 interface). For the interface signals, see Appendix 3.

For details of each signal, refer to the corresponding interface connection manual. (See Section 3.3.1.)

## (2) Displaying the status when it appears that a command is not being executed

Number	Bit	Display	Internal status when 1 is displayed
1000	0	INPOSITION CHECK	The position is being checked.
	1	FEED RATE OVERRIDE	The feedrate override is 0%.
	2	JOG FEED OVERRIDE	The jog feedrate override is 0%.
	3	INT./START LOCK ON	The start lock or interlock is on.
	4	SPEED ARRIVAL CHECK	The CNC is waiting for the speed-attained signal to be turned on.
	5	WAIT REVOLUTION	The CNC is waiting for the signal indicating that the spindle rotates once during threading.
	6	STOP POSITION CODER	The CNC is waiting for the position coder to rotate during spindle feed per rotation.
1001	7	BACKGROUND READING	The CNC is reading the tape in the foreground.
	0	BACKGROUND READING	The CNC is reading the tape in the background.

## (3) Displaying the start disable status

The details of the start disable status are displayed.

If a bit is on, correct the error and start the machine.

When the operator starts the machine, the bit is cleared. Only one of the following bits is on at the same time. If there are two or more causes, only the bit corresponding to the last cause is on.

Number	Bit							
1005	#15	#14	#13	#12	#11	#10	#9	#8

Number	Bit							
1006	#7	#6	#5	#4	#3	#2	#1	#0

The bits indicate the following status when 1 is displayed for them:

- #0 : The automatic operation stop signal (\*SP) is low.
- #1 : An alarm occurred.
- #2 : The SRN or BRN signal is on.
- #3 : An attempt was made to execute the same program in the background.
- #4 : The device is not ready in the tape mode.
- #5 : MDI execution data remains.
- #6 : The tool retraction signal (TRESC) is on. Alternatively, the machine is not at the position when the tool retraction signal was input.
- #7 : The status does not permit the program to be executed in reverse.
- #8 : The status of a DI or DO signal is invalid for a manual numerical command.(\*1)
- #9 : The status of a DI or DO signal is invalid for repositioning.(\*2)
- #10 : Other than the above(\*3)
- #11 to #15: Not used.

\*1 The DO DEN or IPEN signal is high.

Constant surface speed control is being executed.

The status of the DI HEAD1/2 signal is invalid in the MDI mode. (Only for the Series 15-TT)

\*2 The DO OP signal is low for return operation.

The DI MLK signal is on.

The DO STL signal is on.

\*3 The system enters the start lock state during tracing.

A tool is being retracted in the hobbing machine.

On the bed grinder, an alarm is issued or the DI MLK signal is on.

The axis to be retracted in the jog mode is at a position at which starting is disabled.

## (4) Displaying the type of an alarm

The type of the alarm issued is displayed.

When the alarm status is released, the corresponding bit is set to 0.

Number	Bit							
	#15	#14	#13	#12	#11	#10	#9	#8
1007								

Number	Bit							
	#7	#6	#5	#4	#3	#2	#1	#0
1008								

Each bit indicates an alarm type when 1 is displayed for the bit as follows:

- #0 : Background P/S alarm
- #1 : Foreground P/S alarm
- #2 : Overheating
- #3 : Sub-CPU error
- #4 : Excessive synchronous error
- #5 : Parameter writing switch on
- #6 : Overtravel/external data input/output error
- #7 : PMC error
- #8 : External alarm message
- #9 : Not used.
- #10 : Serious P/S
- #11 : Not used.
- #12 : Servo alarm
- #13 : I/O error
- #14 : Input of a parameter requiring power disconnection
- #15 : System error

## (5) Displaying the warning status

The warning status is displayed.

When the warning status is released, the bit is set to 0.

Number	Bit							
	#7	#6	#5	#4	#3	#2	#1	#0
1009								

A bit indicates the following status when 1 is displayed for it.

- #0 : The system is in the warning state.
- #1 to #7 : Not used.



## (6) Displaying the reset status

The reset status and the status of input signals related to feed hold are displayed.

Number	Bit							
	7	6	5	4	3	2	1	0
1010								
					RST	ERS	RRW	ESP

The bits indicate the following status when 1 is displayed for them:

ESP : The emergency stop status is indicated.

RRW : The reset and rewind signal is on.

ERS : The external reset signal is on.

RST : The reset key is pressed.

## (7) Displaying the details of a TH alarm

The details of a TH alarm are displayed.

Number	Display	Description
1100	POSITION (CHARACTER) F	Location of the character for which a TH alarm is issued indicated as the number of characters from the beginning of the block (TH alarm in the foreground)
1101	BIT PATTERN (CHARACTER) F	Read code of the character for which a TH alarm is issued with a bit pattern (TH alarm in the foreground)
1100	POSITION (CHARACTER) B	Location of the character for which a TH alarm is issued indicated as the number of characters from the beginning of the block (TH alarm in the background)
1101	BIT PATTERN (CHARACTER) B	Read code of the character for which a TH alarm is issued with a bit pattern (TH alarm in the background)

## (8) Displaying position deviation

The positional deviation of each axis is displayed.

Number	Display	Description
3000	X SERVO ERROR	Positional deviation along the X-axis in the detection unit
	Y SERVO ERROR	Positional deviation along the Y-axis in the detection unit
	Z SERVO ERROR	Positional deviation along the Z-axis in the detection unit
	:	
	:	

## (9) Displaying servo control information

Servo control information is displayed.

3010 to 3023	Servo control information for axis 1
3030 to 3043	Servo control information for axis 2
3050 to 3063	Servo control information for axis 3
3070 to 3083	Servo control information for axis 4
3090 to 3103	Servo control information for axis 5
3110 to 3123	Servo control information for axis 6
3130 to 3143	Servo control information for axis 7
3150 to 3163	Servo control information for axis 8
3170 to 3183	Servo control information for axis 9
3190 to 3203	Servo control information for axis 10
3210 to 3223	Servo control information for axis 11
3230 to 3243	Servo control information for axis 12
3250 to 3263	Servo control information for axis 13
3270 to 3283	Servo control information for axis 14
3290 to 3303	Servo control information for axis 15

## · Checking a disconnection or overload alarm

If a message indicating an overload alarm (SV 023) or disconnection alarm (SV 015) appears on the screen, check the diagnostic data to see if the data indicates an overload or disconnection alarm. The number of the diagnostic data is 3014 for axis 1, 3034 for axis 2, 3054 for axis 3, and the start number + 4 for other axes.

#7	#6	#5	#4	#3	#2	#1	#0
OVL	LVAL	OVC	HCAL	HVAL	DCAL	FBAL	OFAL

When an overload alarm is issued: #7 = 1

When a disconnection alarm is issued: #1 = 1

## Details of digital servo alarms

#7	#6	#5	#4	#3	#2	#1	#0
OVL	LVAL	OVC	HCAL	HVAL	DCAL	FBAL	OFAL

Symbol	Description
OFAL	LSI OVERFLOW An overflow alarm occurred in the digital servo.
FBAL	PULCO DISCONNECTION A disconnected pulse coder alarm occurred.
DCAL	EXCESS I FROM MOTOR A regenerative discharge circuit alarm occurred in the servo amplifier. (LED DC on the servo amplifier is on.)
HVAL	EXCESS V TO MOTOR An overvoltage alarm occurred in the servo amplifier. (LED HV on the servo amplifier is on.)
HCAL	ABNORMAL CURRENT IN SERVO An abnormal current alarm occurred in the servo amplifier. (LED HC on the servo amplifier is on.)
OVC	EXCESS CURRENT IN SERVO An overcurrent (overload) alarm occurred in the servo amplifier.
LVAL	POWER V TOO LOW An insufficient voltage alarm occurred in the servo amplifier. (LED LV on the servo amplifier is on.)
OVL	SV OVERLOAD An overload alarm occurred in the servo motor or amplifier. When this alarm occurs in the servo amplifier, the servo amplifier, separate discharge unit, or power transformer is overheated. (LED OH on the servo amplifier is on.)

Then check the diagnostic data to determine the cause of the alarm. The number of the diagnostic data is 3015 for axis 1, 3035 for axis 2, 3055 for axis 3, and the start number + 5 for other axes.

Check bits 7 and 4 at the address to determine the cause of the alarm by consulting the following table.

#7	#6	#5	#4	#3	#2	#1	#0
ALDF			EXPC				

Cause of the alarm	7 bit ALDF	4 bit EXPC
Motor overheated	1	0
Amplifier overheated	0	0
Disconnected built-in pulse coder (hard)	1	0
Disconnected separate pulse coder (hard)	1	1
Disconnected pulse coder (soft)	0	0

**Example** When a disconnection alarm (SV 015) is issued for axis 1, assume that the diagnostic data of Nos. 3014 and 3015 is as follows:

No. 3014: 00000010

No. 3015: 10110100

FBAL (bit 1) of diagnostic data No. 3014 is set to 1.

Both ALDF (bit 7) and EXPC (bit 4) of diagnostic data No. 3015 are set to 1. The diagnostic data indicates that the cause of the alarm is a disconnected separate pulse coder (hard).

· Checking an absolute-position detection alarm

If an alarm is detected at power-on when the absolute position is detected optionally, the message SV101 DATA ERROR (ABS PCDR) or OT032 NEED ZRN (ABS PCDR) appears. The cause of the alarm is indicated in the diagnostic data.

If the alarm message SV101 DATA ERROR (ABS PCDR) or OT032 NEED ZRN (ABS PCDR) appears on the screen, the cause of the alarm is indicated in the diagnostic data. The number of the diagnostic data is 3018 for axis 1, 3038 for axis 2, 3058 for axis 3, and the start number + 8 for other axes.

#7 #6 #5 #4 #3 #2 #1 #0

APMVAL	APPER	APFER	APTER	APCER	APBATZ	APPLSM	APNZRN
--------	-------	-------	-------	-------	--------	--------	--------

Symbol	Description (Action to be taken)
APNZRN	Absolute-position detection is not correlated with the reference position. (Action: Correlate absolute-position detection with the reference position.)
APPLSM	A pulse error alarm occurred. (Action: Correlate the absolute-position detection with the reference position.)
APBATZ	The voltage of the battery of the absolute pulse coder is 0. (Action: Replace the battery and correlate absolute-position detection with the reference position.)
APCER	A communication error occurred during data transmission. (Action: Replace the pulse coder.)
APTER	A time-out error occurred during data transmission. (Action: Replace the pulse coder.)
APFER	A framing error occurred during data transmission. (Action: Replace the pulse coder.)
APPER	A parity error occurred during data transmission. (Action: Replace the pulse coder.)
APMVAL	An excessive motor displacement alarm occurred. This alarm occurs if the machine moves by more than 24,000 pulses in the detection unit at power-on. (Action: Take appropriate action for the machine so that it does not move at power-on.)

### 3.4 Displaying System Configurations

The software and hardware configuration of the CNC unit can be displayed on the CRT display. This feature allows you to easily obtain hardware or software information necessary, for example, when maintaining the CNC.

The system configuration screen displays the following information:

- (1) Software information : The series and edition of the CNC control software, assemblies providing the software, and DRAM size are displayed. The machine name is displayed if registered in PRM 2390 to 2399.  
The series and edition are also displayed for other software, including that enabling help messages, system boot, digital servos, serial spindle amplifiers, and PMC control.
- (2) Slot information : For each slot (physical slot) on the FBUS, the type and ID of the PCB inserted into that slot, if any, is displayed. If the PCB features a CPU, the series and edition of the software are also displayed.
- (3) Module information : The names and types of the modules mounted on each PCB are displayed. No information is displayed for those PCBs on which no module is mounted.

(1) Displaying information (When 9" CRT/MDI is used)

1. Specify the SERVICE screen.

SETTING	SERVICE	MESSAGE		CHAPTER	+
---------	---------	---------	--	---------	---

2. Press the SYSTEM soft key.

PARAM	PITCH	DIAGNOS	DSP.MEM	CHAPTER	+
-------	-------	---------	---------	---------	---

	SYSTEM			CHAPTER	+
--	--------	--	--	---------	---

3. Press the page keys (   ) to switch the screen.

(2) Screen

(a) Software information (When 9" CRT/MDI is used)

SYSTEM CONFIG (SOFTWARE) 01234 N12345		
CNC SYSTEM ID	:	SERIES / EDITION
F15M9A1.	:	AAB12. 00013.
ASSEMBLY	EDITION	DRAM SIZE
BASIC4.	00015.	8MBYTE6.
OPTION A1	0001	
OPTION A2	0001	
OPTION A3	0001	MACHINE NAME
OPTION A4	—	ABCDEFGHIJ7.
BASIC (SUB)	0001	
OPTION S1	—	
MEM *** STOP **** * 01:23:45 LSK		
	<b>SYSTEM</b>	CHAPTER+

1. CNC system ID
2. CNC control software series
3. CNC control software general edition
4. Assemblies providing CNC control software
5. Edition of each assembly (A dash indicates that the assembly is not used.)
6. DRAM size of CNC
7. Machine name (displayed only when set in PRM 2390 to 2399)

```

SYSTEM CONFIG (SOFTWARE)  O1234 N12345

SOFTWARE KIND   : SERIES / EDITION
HELP MESSAGE1. : AH002. / 00013.
SYSTEM BOOT    : 6014 / 0005
DIGITAL SERVO  : 9060 / 0005
SERIAL SPDL #1 : 9A20 / 0008
SERIAL SPDL #2 : 9A20 / 0008
PMC-NA        : 4046 / 0005
GRAPHIC       : 6001 / 0003
RMT BUF/DNC1  : 609A / 0004

MEM *** STOP **** *** *** 01:23:45 LSK
          SYSTEM                CHAPTER+

```

1. Software type
2. Software series
3. Software edition

## (b) Slot information

```

SYSTEM CONFIG (SLOT)      O1234 N12345

SLOT      KIND          ID          SER./VER.
1.00:0    CNC CPU BOARD2. 3.1262:37  AAB1/00014.
02:1      PMC CPU BOARD  2077:3D   4046/0005
03:3      CNC SUB CPU BOARD F163:3A  AAB1/0001
04:4      GRAPHIC        0145:40  6001/0003
84:6      REMOTE BUFFER  013F:3C  609A/0004

MEM *** STOP **** *** *** 01:23:45 LSK
          SYSTEM                CHAPTER+

```

## 1.: Slot number

XX : X

- Physical slot number of FBUS 00 to 0F (primary slots on the front)  
80 to 8F (secondary slots on the back)
- Logical slot number (slot number, logically assigned by CNC control software immediately after power-on)

## 2. : Type of printed-circuit board

## 3. : ID number

XXXX : XX

Module ID (See Section 1.3 for details.)	XX3F : Remote buffer mode
	XX45 : Graphic CPU board
	XX62 : Main CPU board (high-speed)
	XX63 : Additional axis/sub-CPU board
	XX6B : PMC-NB board
	XX6C : FAPT/IAP CPU board
	XX71 : Main CPU board (standard)
	XX74 : ROM cassette adapter
	XX77 : PMC-NA board
	Software ID
	39 : NON CPU SUB
	3A : SUB CPU
	3C :RMT-BUF/DNC1
	3D :PMC-NA CPU
	40 : Graphic CPU
	41 : ROM cassette adapter
	42 : PMC-NB CPU
	44 : DNC1 #2
	45 : FAPT CPU
	4C :TC CPU
	4D :IAP CPU

## 4. : Series and edition of software (displayed only for modules featuring a CPU)

## (c) Module information

```

SYSTEM CONFIG (MODULE)  O1234 N12345

1.CMC MAIN CPU BOARD
MODULE
2.PROGRAM MEMORY (FROM) : 6MBYTE3.
MAIN MEMORY (DRAM) : 4MBYTE
MAIN MEMORY (SRAM) : TYPE A
TAPE MEMORY (FILE) : 512KBYTE
PERIPHERAL MODULE : -
CHARACTER CONTROL : 9" CRT
SPINDLE CONTROL : SERIAL, HI-DI
SERVO CONTROL 1/2 : DIGITAL
SERVO CONTROL 3/4 : DIGITAL

MEM *** STOP **** *** 01:23:45 LSK
SYSTEM CHAPTER+

```

## 1. Name of printed-circuit board

Module information is displayed for the following printed-circuit boards (if mounted):

- |                                  |                              |
|----------------------------------|------------------------------|
| (1) CNC main CPU board           | (2) CNC sub-CPU board        |
| (3) Additional axis board 1      | (4) Additional axis board 2  |
| (5) PMC-NA CPU board             | (6) PMC-NB CPU board         |
| (7) Graphic CPU board            | (8) Remote buffer/DNC2 board |
| (9) DNC1 CPU board               | (10) CAP/FAPT CPU board      |
| (11) RISC CPU board              | (12) MMC-II main CPU board   |
| (13) MMC-II graphic CPU board    | (14) MMC-III main CPU board  |
| (15) Axis CPU board (multi-axis) |                              |

## 2. Module name

The names of the modules mounted on the printed-circuit board, if any, are displayed.

## 3. Module type

The type of each module is displayed if there are two or more types of a certain module, such as types having different capacities. A dash is displayed for those modules for which there is only a single type.

– Modules mounted on each printed-circuit board

1) CNC main CPU board

Module name	Module types (number of types)
1. Program memory (FROM)	2M, 4M, 6M, 8M, 10M, 12M, 14MBYTE (7)
2. Main memory (DRAM)	2M, 4M, 8MBYTE (3)
3. Main memory (SRAM)	TYPE-A, B, C, D, E, F, G, (7)
4. Tape storage memory (FILE)	64K, 128K, 256K, 512K, 1M, 2MBYTE (6)
5. Peripheral module	– (1)
6. Character control	9", 10", 14" (3)
7. Spindle control	SERIAL, ANALOG, (HDI) (4)
8. Axis control 1/2	DIGITAL, ANALOG (2)
9. Axis control 3/4	DIGITAL, ANALOG (2)

2) CNC sub-CPU board

Module name	Module types (number of types)
1. Sub-CPU memory 1 (DRAM)	1M, 1.25M, 2M, 4M, 8M (5)
2. Sub-CPU memory 1 (SRAM)	TYPE-A, B, C, D, E, F, G, (7)
3. Sub-CPU memory 2	64K, 128K, 256K, 512K, 1M, 2MBYTE (6)
4. Spindle control	SERIAL, ANALOG, (HDI) (4)
5. Axis control 5/6	DIGITAL, ANALOG (2)
6. Axis control 7/8	DIGITAL, ANALOG (2)
7. Analog I/O module	PORT-B, ANALOG-IN/OUT (7)

3) Additional axis board 1

Module name	Module types (number of types)
1. Spindle control	SERIAL, ANALOG, (HDI) (4)
2. Axis control 5/6	DIGITAL, ANALOG (2)
3. Axis control 7/8	DIGITAL, ANALOG (2)
4. Analog I/O module	PORT-B, ANALOG-IN/OUT (7)

4) Additional axis board 2

Module name	Module types (number of types)
1. Axis control 9/10	DIGITAL, ANALOG (2)

5) PMC-NA CPU board

Module name	Module types (number of types)
1. CPU module	– (1)
2. PMC engine module	BOC2 (1)
3. Optional DRAM module	512K, 1M, 2MBYTE (3)
4. Program memory (FROM)	1M, 1.5M, 2MBYTE (3)

6) PMC-NB CPU board

Module name	Module types (number of types)
1. CPU module	– (1)
2. PMC engine module	PMP (1)
3. Optional DRAM module	512K, 1M, 2MBYTE (3)
4. Program memory (FROM)	1M, 1.5M, 2MBYTE (3)
5. EPROM module	512K, 768K, 1MBYTE (3)

7) Graphic CPU board

Module name	Module types (number of types)
1. CPU module	– (1)
2. Character control	9", 10", 14" (3)
3. Graphic engine 1	– (1)
4. Graphic engine 2	– (1)



## 8) Remote buffer/DNC2

Module name	Module types (number of types)
1. Communication module	— (1)

## 9) DNC1 CPU board

Module name	Module types (number of types)
1. Communication module	— (1)

## 10) CAP/FAPT CPU board

Module name	Module types (number of types)
1. CPU module	— (1)
2. EPROM module	512K, 768K, 1MBYTE (3)
3. SRAM module	128K, 256K, 512K, 1MBYTE (4)
4. DRAM module	128K, 256K, 512K, 1MBYTE (4)

## 11) RISC CPU board

Module name	Module types (number of types)
1. EPROM module	512K, 1MBYTE (2)
2. SRAM module	512K, 1MBYTE (2)
3. DRAM module 1	1M, 2MBYTE (2)
4. DRAM module 2	1M, 2MBYTE (2)

## 12) MMC-II main CPU board

Module name	Module types (number of types)
1. RAM file module	128K, 256K, 512K, 1M, 2M, 4M, (6)
2. ROM file module 1	128K, 256K, 512K, 1M, 2M, 4M, (6)
3. ROM file module 2	128K, 256K, 512K, 1M, 2M, 4M, (6)
4. SCC module	— (1)
5. DMA module	— (1)
6. DRAM module 1	1M, 2M, 4M, 8M (4)
7. DRAM module 2	1M, 2M, 4M, 8M (4)

## 13) MMC-II graphic board

Module name	Module types (number of types)
1. Graphic engine	— (1)

## 14) MMC-III main CPU board

Module name	Module types (number of types)
1. System control	2-PORT, 3-PORT (2)
2. Graphic control	4-SCREEN, 8-SCREEN (2)
3. Character control	— (1)
4. Main memory (DRAM)	1.5M, 2.5M, 3.5M, 4.5M, 6M, 8MBYTE (6)
5. Program memory (FROM)	1M, 2M, 3M, 4M, 6MBYTE (5)
6. Data file (SRAM)	128K, 256K, 1M, 2MBYTE (4)

## 15) Axis CPU board (axis CPU 1 to 6)

Module name	Module types (number of types)
1. Axis CPU memory (DRAM)	1M, 1.25M, 2M, 4M, 8M (5)
2. Spindle control	SERIAL, ANALOG, (N-ZERO) (4)
3. Axis control 1/2	DIGITAL, ANALOG (2)
4. Axis control 3/4	DIGITAL, ANALOG (2)
5. Malfunction check module 1	2-POS, 4-POS (2)
6. Malfunction check module 2	2-POS, 4-POS (2)

## 4. CONFIRMING POWER SOURCE VOLTAGE AND POWER CONNECTION

### 4.1 Confirming Power Source Voltage

#### 4.1.1 Power supply in the control unit

Confirm that the AC power being supplied to connector CP1 of the power supply in the control unit fulfills the following conditions.

200 VAC +10% -15%, 50/60Hz ±1Hz, single phase

220 VAC +10% -15%, 50/60Hz ±1Hz, single phase

The following two LEDs are located on the power supply of the control unit.

PIL (green) : Pilot lamp

Indicates the power supply unit is ready for operation.

ALM (red) : Alarm lamp

This LED indicates the power supply has detected a fault. The fault could be the result of something like a direct current output short-circuit.

For normal NC control unit operation, the PIL LED should be on and the ALM LED should be off.

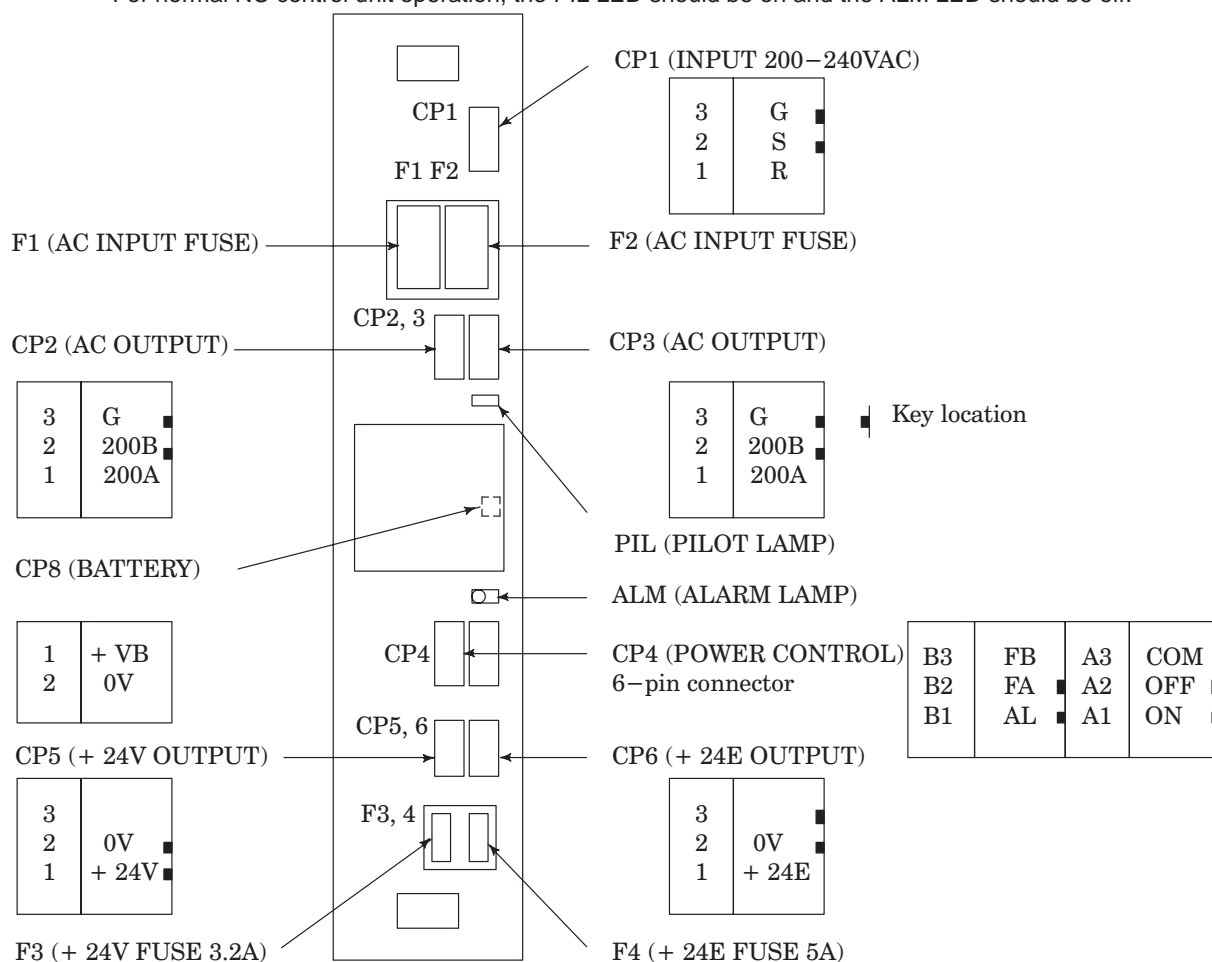

**Note 1) Connector compatibility**

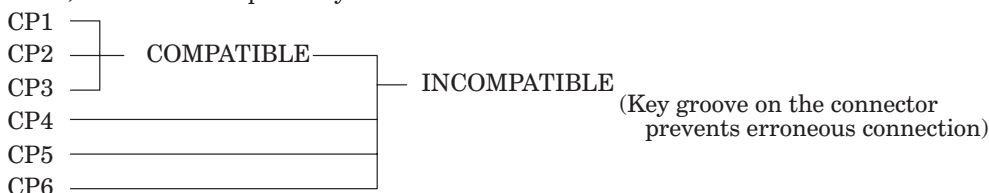

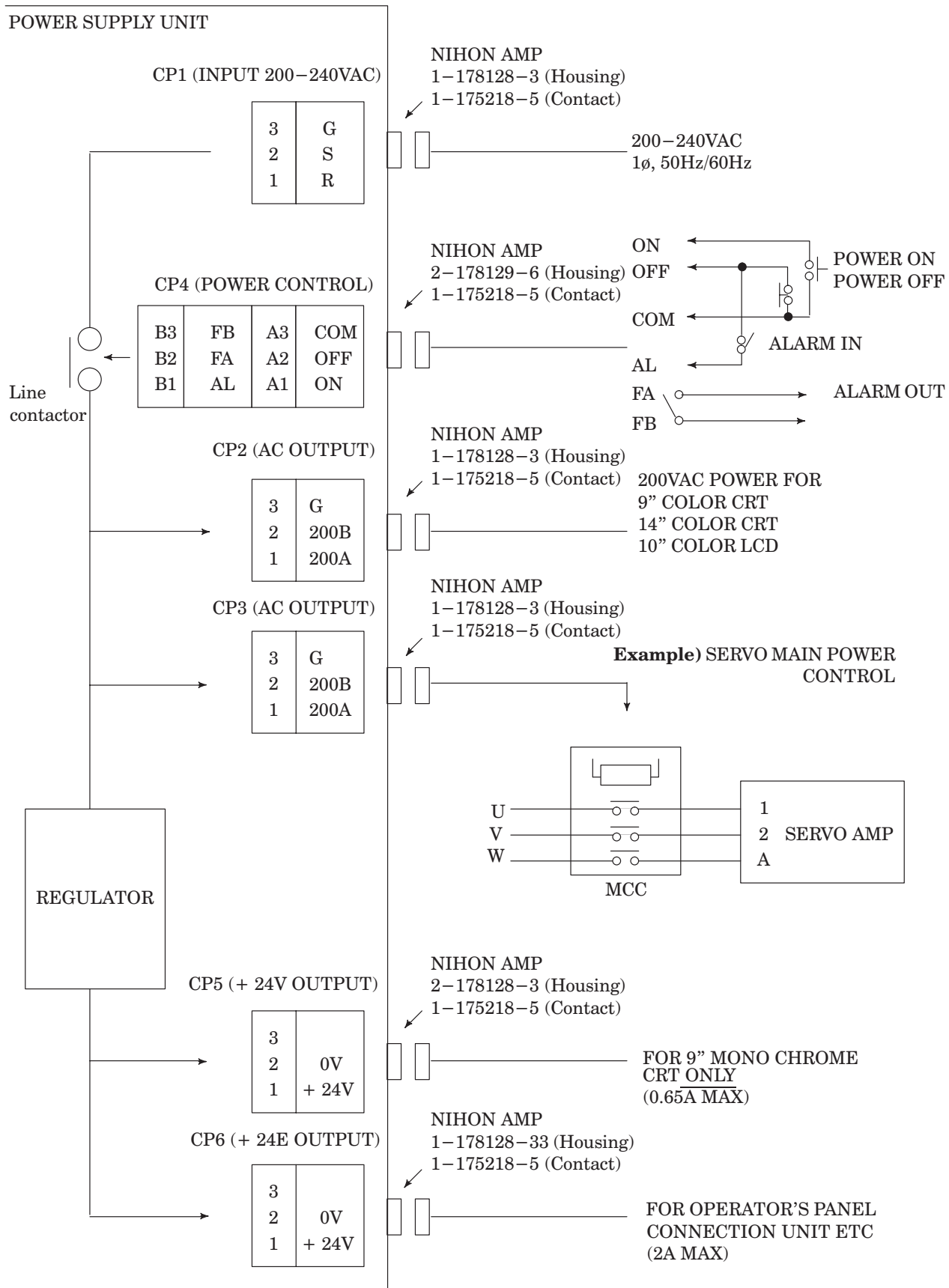

#### 4.1.2 Servo amplifier

- (1) Checking the voltage of the control section of the servo amplifier

Check the DC voltage of the control section of the servo amplifier for each axis. Refer to the maintenance manual of each servo unit for details of how to perform this check.

- (2) 100 V power supply for MCC control

To operate the conductor (MCC) which connects the servo amplifier output to the servo motor, 100 VAC must be supplied to the servo amplifiers for each axis.

When checking the voltage, it is necessary to release the emergency stop switches on the operator's panel and machine. Otherwise, the emergency stop contact in the power supply would close, resulting in the output of an alarm.

#### 4.1.3 Checking the ground connection

Check that the SYSTEM GND of the NC unit is correctly grounded. Check also that each individual unit is correctly grounded.

For details of grounding, refer to the item covering countermeasures against noise in the FANUC Series 15-MODEL B Connection Manual (B-62073).

## 4.2 Confirmation of Power Supply Connection

### 4.2.1 Tap change of control power transformer

A control power transformer is required when the input power supply is other than 200 VAC 50/60 Hz or 220 VAC 50/60 Hz.

Check the transformer tap, and confirm that the voltage (at the NC power supply terminal) is within +10% and -15% of the tap voltage. If the voltage is outside this range, the tap must be changed.

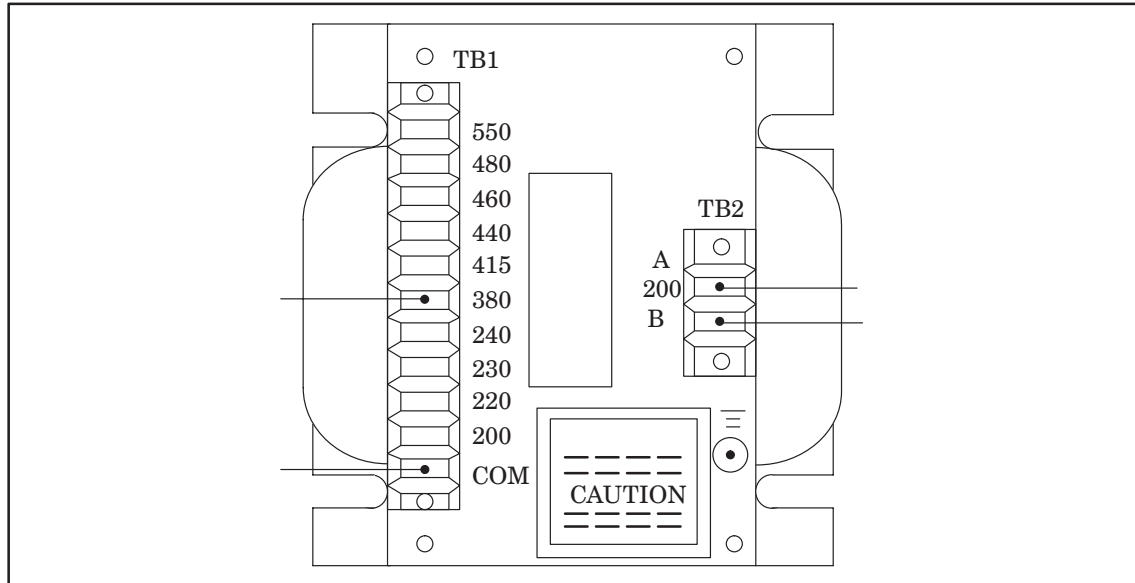

Fig. 4.2.1 Tap connection for 380 VAC

### 4.2.2 Connection of AC servo power transformer

A power transformer is required when the input power supply is other than 200 to 230 VAC. In this case, make sure the input tap of the power supply transformer is set according to the input voltage when connecting the power supply cable to the AC servo unit.

If set incorrectly, the AC servo amplifier may cause trouble.

#### 1) Primary side connection

Connection of the transformer terminals and power supply cables U, V, and W must follow the input supply voltage specifications in Table 4.2.2.

Table 4.2.2 Connection of Input Power Cables for the Transformer and Connection between Primary Terminals

Power voltage	Connection of power cables U, V, W	Terminals to be connected	Remarks
200V	U-7, V-15, W-23	8-15, 16-23, 24-7	Delta connection
220V	U-6, V-14, W-22	8-14, 16-22, 24-6	
230V	U-5, V-13, W-21	8-13, 16-21, 24-5	
240V	U-4, V-12, W-20	8-12, 16-20, 24-4	
380V	U-6, V-14, W-22	8-16, 16-24 or (8-16-24)	Star connection
415V	U-4, V-12, W-20		
460V	U-3, V-11, W-19		
480V	U-2, V-10, W-18		
550V	U-1, V-9, W-17		

### 4.3 Confirming CNC Control Unit Connection

#### 4.3.1 Series 15-MB total connection diagram (In case of serial spindle)

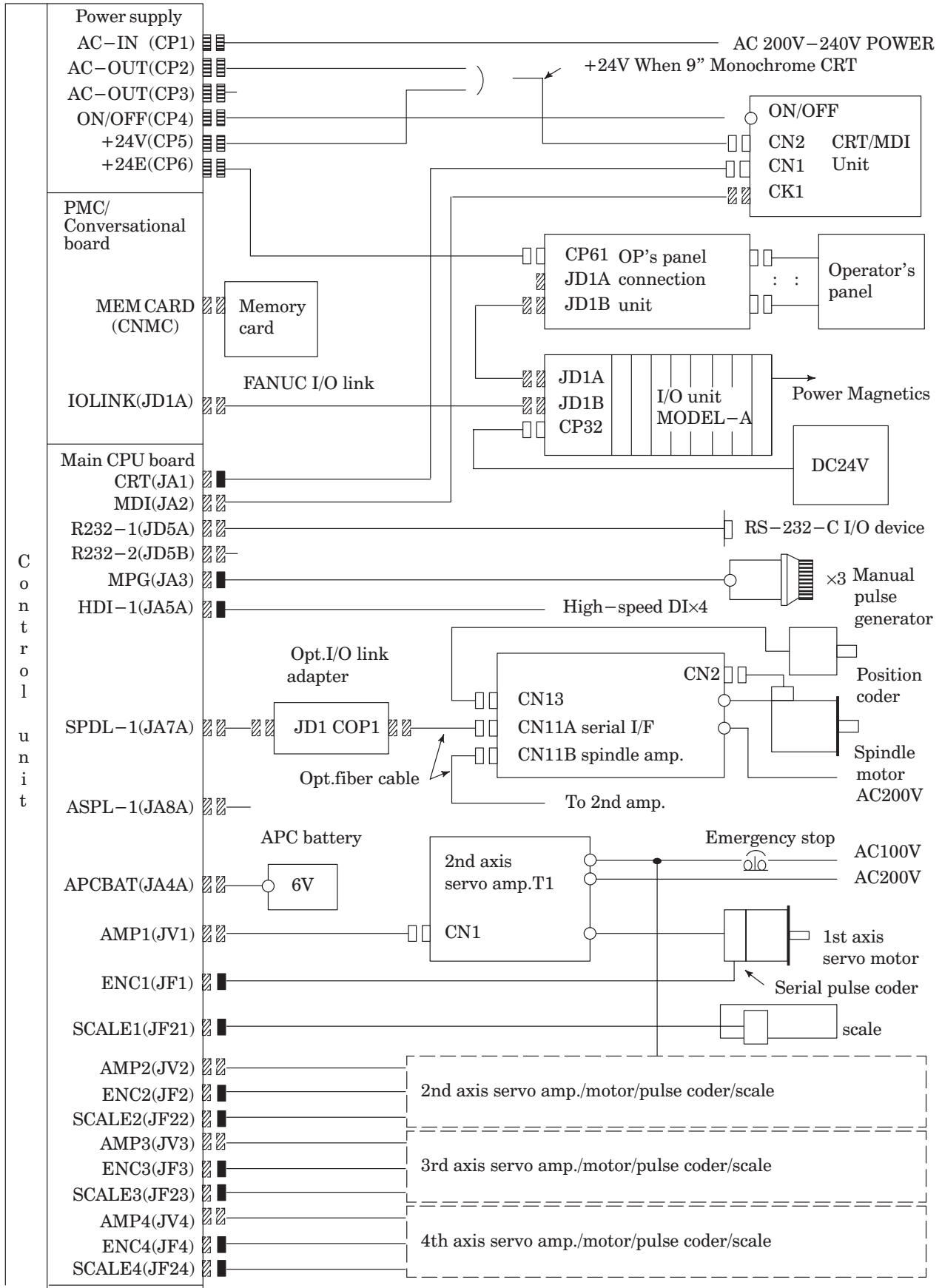

Fig. 4.3.1 (a) Total Connection Diagram (1/2)

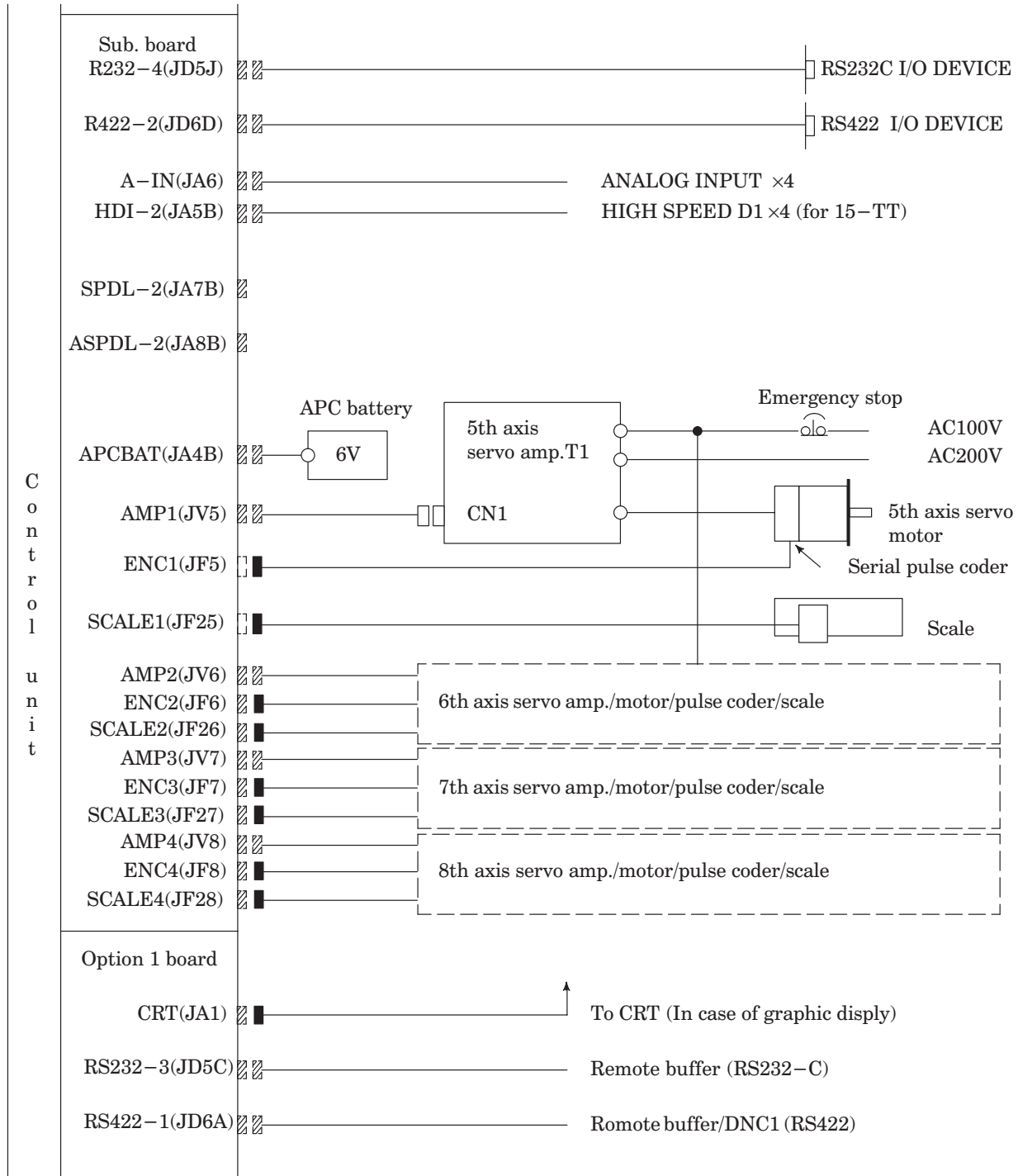

Fig. 4.3.1 (a) Total Connection Diagram (2/2)

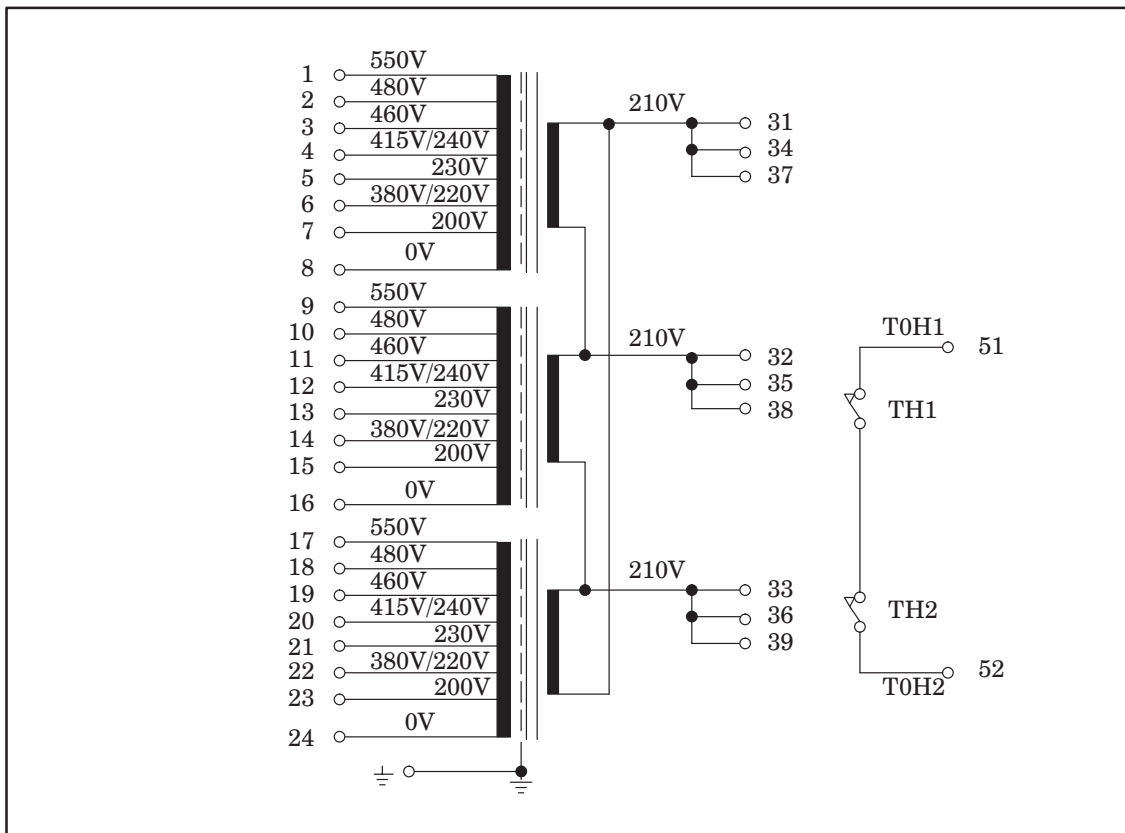

Fig. 4.3.1 (b) Connection Diagram

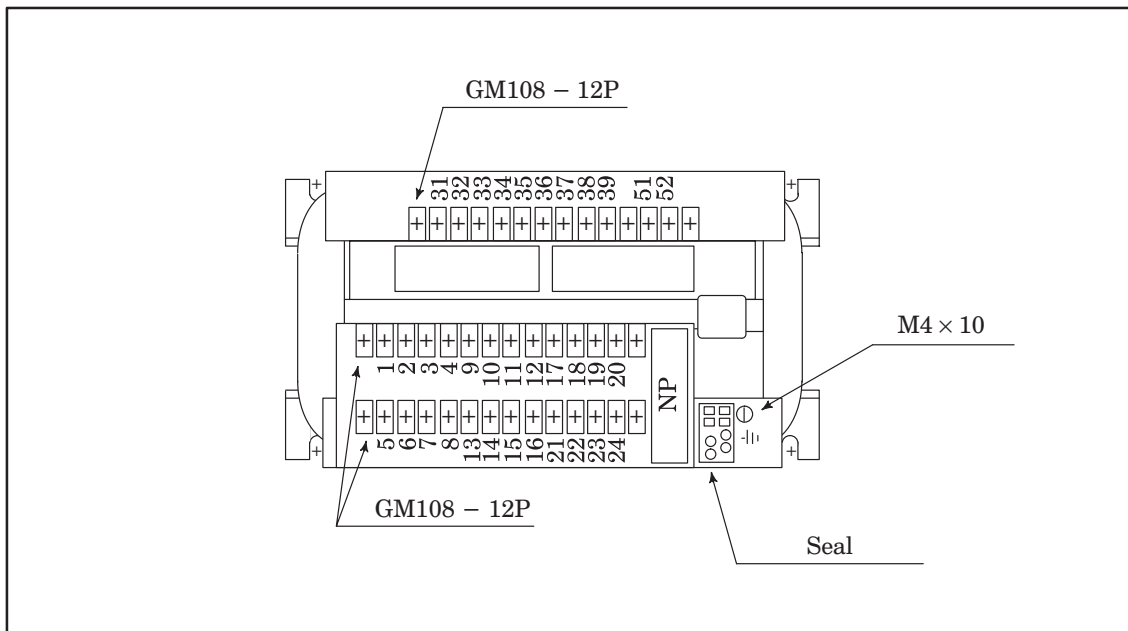

Fig. 4.3.1 (c) Pin Assignment of the Servo Power Transformer



### 4.3.2 Connection of FANUC I/O Link

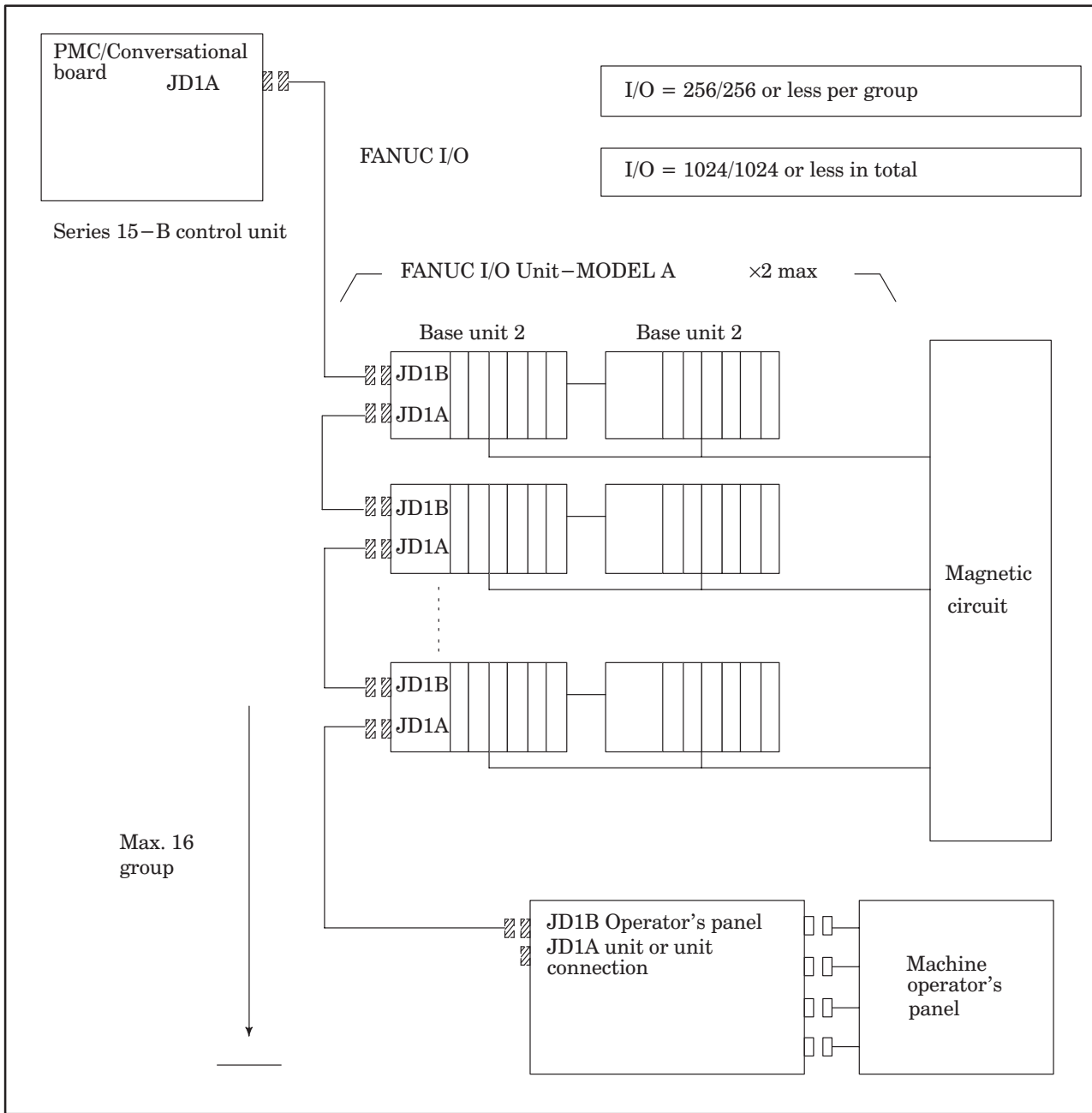
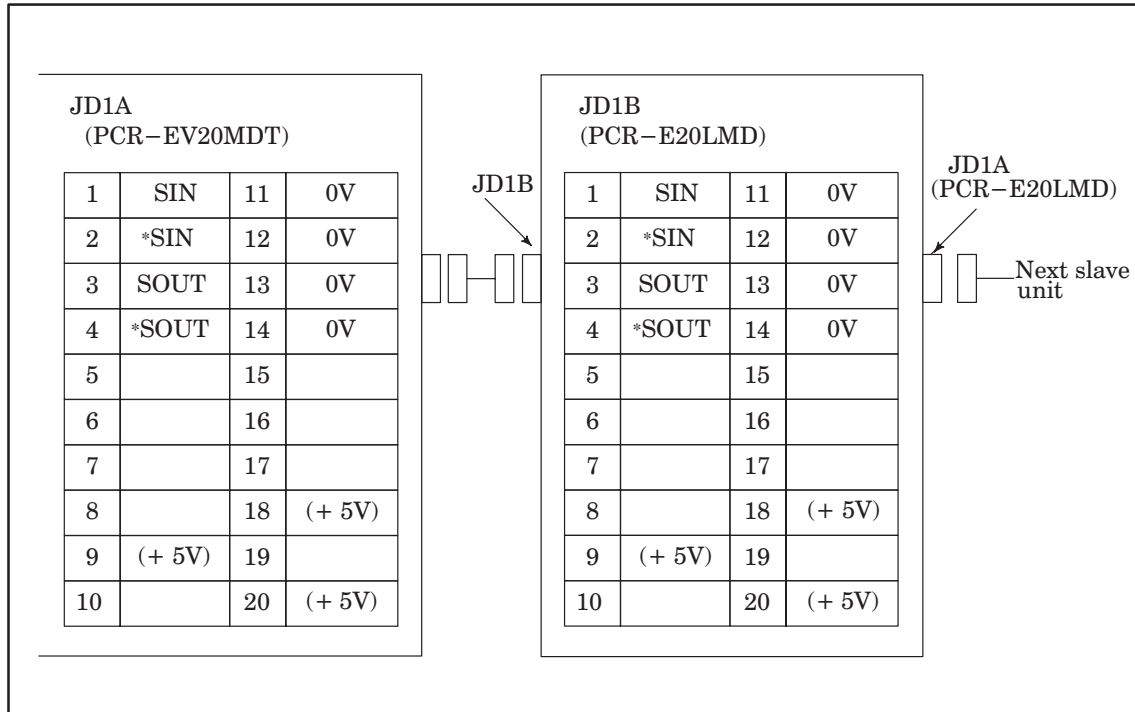

Fig. 4.3.2 I/O Link connection Diagram

- (1) Connection of FANUC I/O link by metal cable  
Series 15-B control unit or former slave unit



+5 V terminals are for an optical I/O link adapter. They are not used when connecting with a metal cable.

- (2) Connection of FANUC I/O link by optical fiber cable

The FANUC I/O Link can be extended to the maximum length of 200 m with optical fiber cables using an optical I/O link adapter.

- (a) Connection diagram

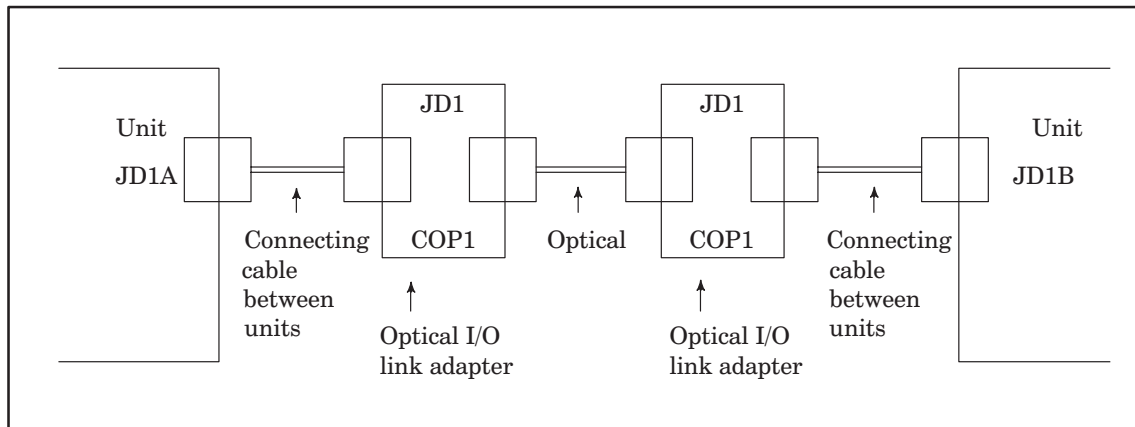

## (b) Interunit connecting cables

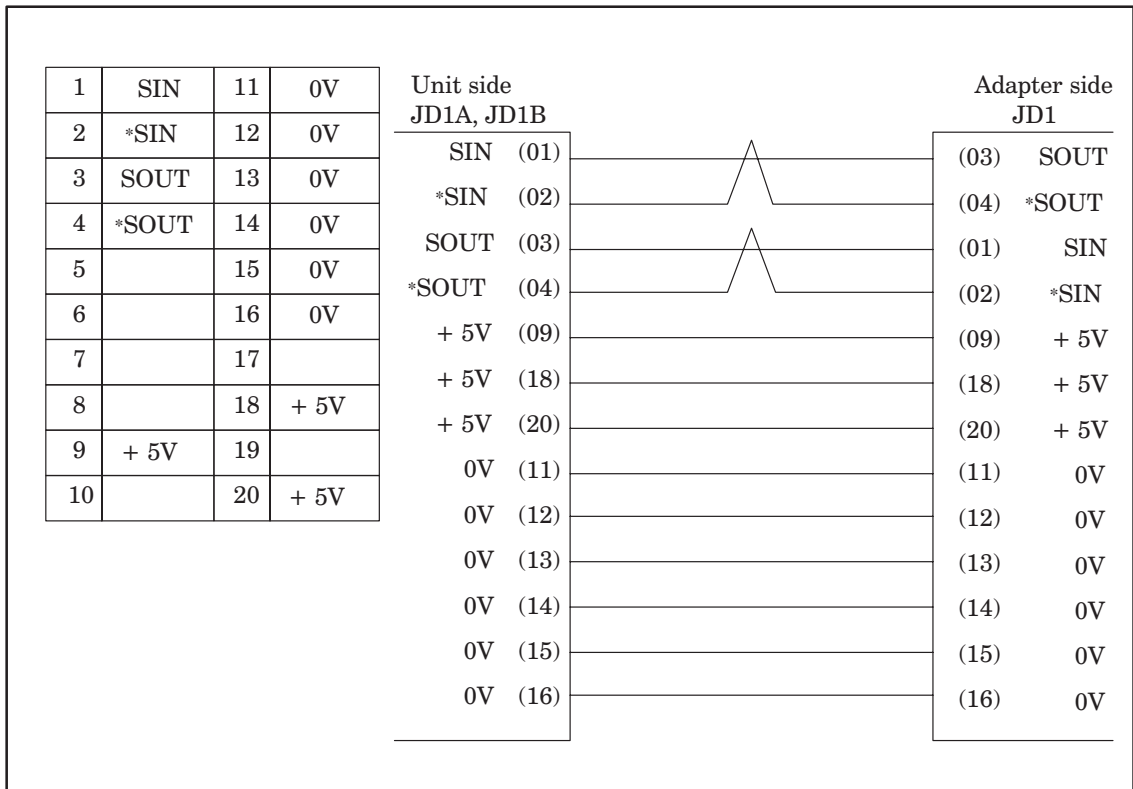

1. Recommended connector for cable side : PCR-E20FS (made by HONDA communication Co., Ltd.)
2. Recommended cable (wire material): A66L-0001-0284#10P
3. Cable length: Max. 2 m (when the recommended cable is used)

## (c) Optical cable

1. Specification: A66L - 6001 - 0009 (Make sure to use one with this specification)
2. Cable length: Max. 200 m

### 4.3.3 Optical fiber cable

This CNC uses optical cables for connections between the control unit and the I/O unit. Unlike the conventional power cables, optical fiber cables need special care in installation and handling.

(1) External view of optical fiber cable

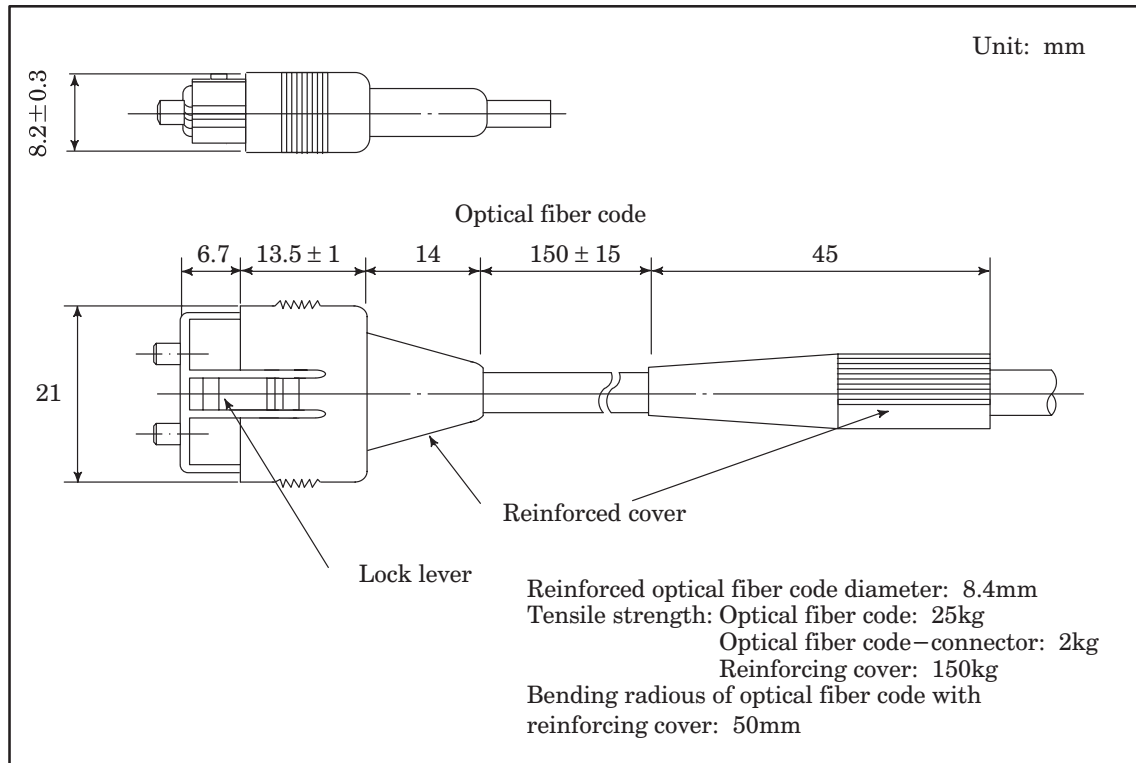

- (a) Standard length of an optical fiber cable is 5, 10, and 15 meters.
- (b) An optical fiber cable cannot be cut and joined at machine manufacturers side.
- (c) If it needs to relay on cabling, use optical fiber adapter. Up to one relay points are allowed on a transmission line.

(2) Optical fiber cable clamping method

When reinforcing cover is fixed at cable clamp with sponge, enough sag at optical fiber code as shown below is necessary so that connecting part of optical should not be weighed directly by optical fiber cable.

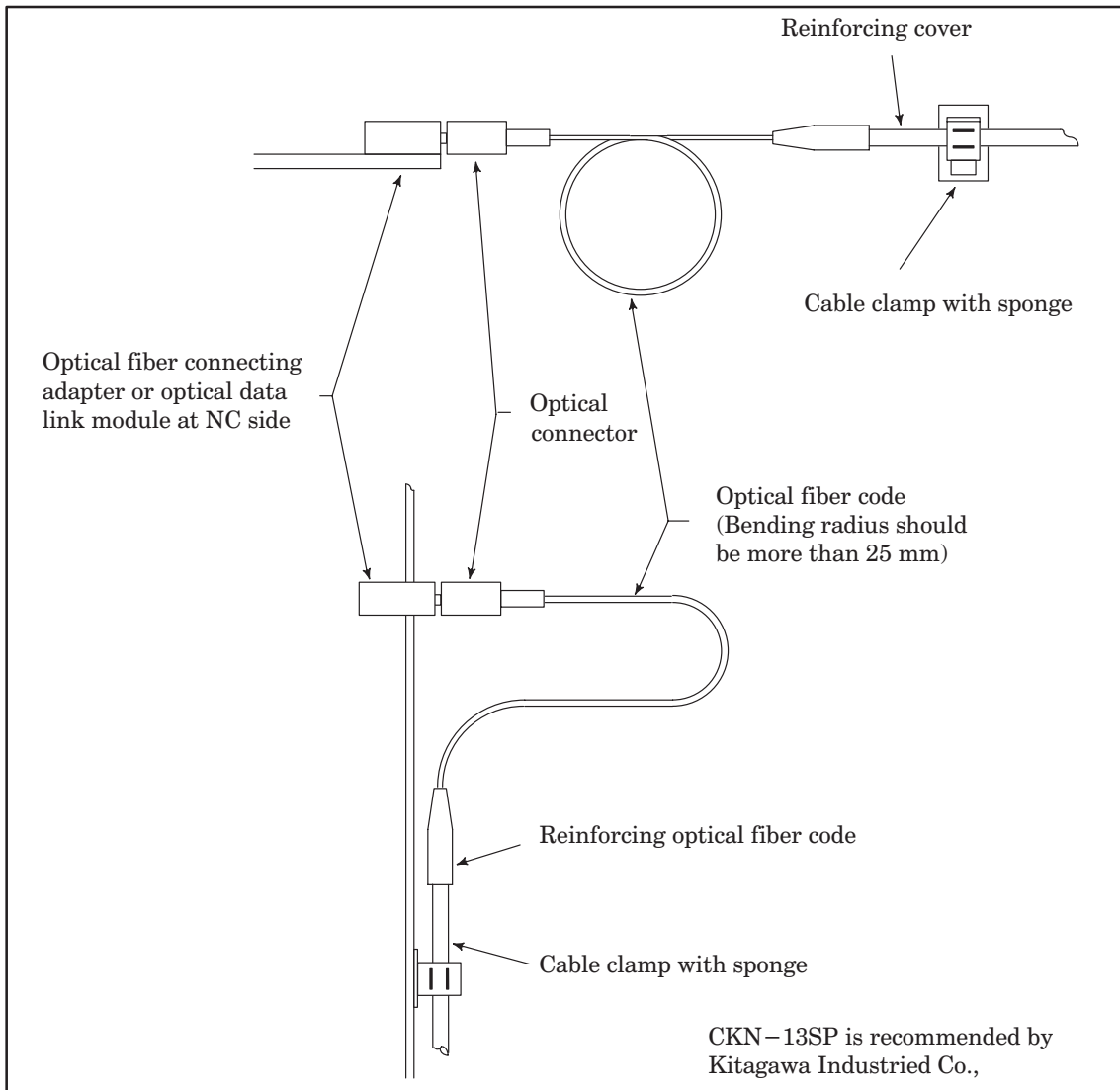

(3) Relay using an optical fiber adapter

(a) External view of an optical fiber adapter

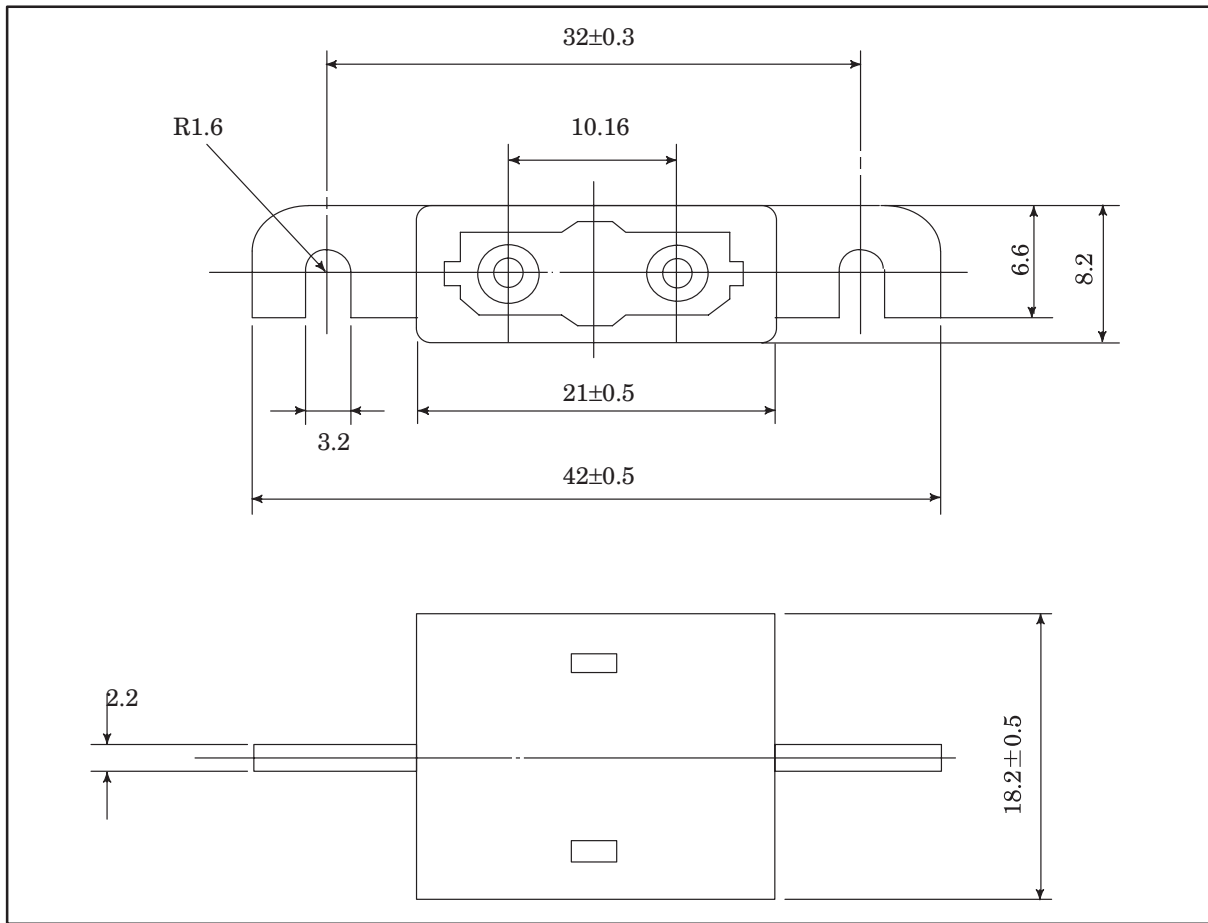

(b) Example of the use of an optical fiber adapter

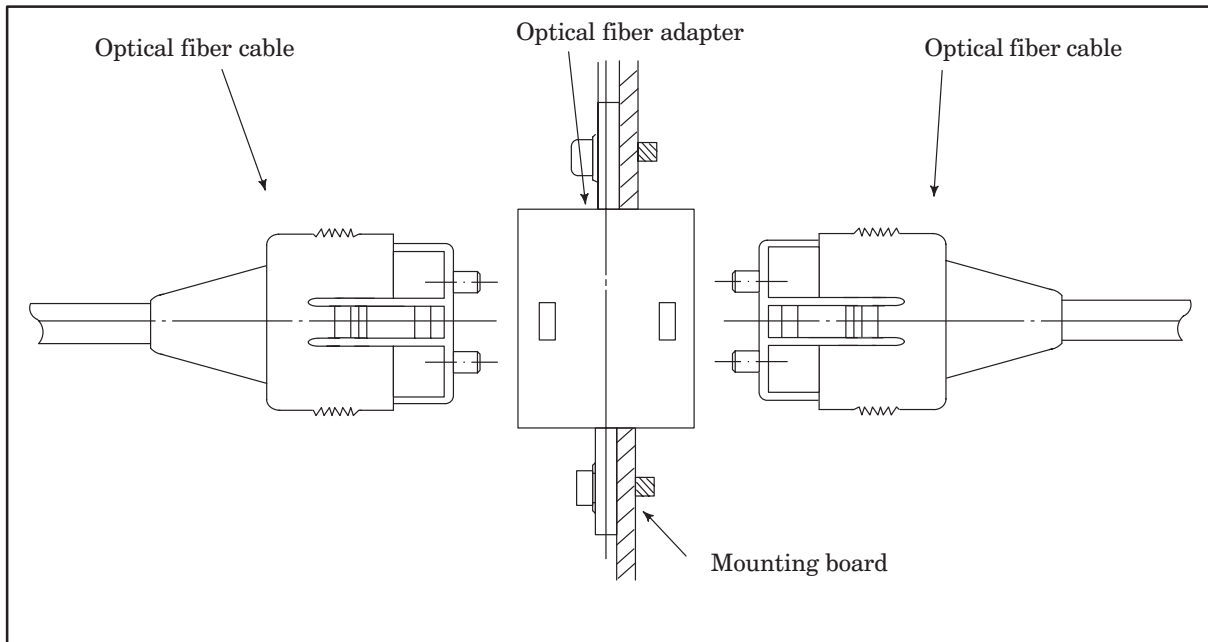

**NOTE** Up to one relay points are permitted.

## (4) Maximum transmission distance by optical fiber cable

Maximum transmission distance by optical fiber cable is shown below:

Maximum transmission distance varies depend on numbers of relay points by optical fiber adapter.

Relay points	Max. trans. distance (total)
0	200m
1	100m

## (5) Notice of optical fiber cable handling

- (a) Even though reinforcing cover used on the optical fiber code has enough mechanical strength, be sure not to be damaged by heavy materials drop.
- (b) Detaching and attaching of optical connector should always be made by touching connector. Optical fiber code should not be touched when replacement.
- (c) Optical connector is automatically locked with upper side lock levels after being connected. It is impossible to pull out the connector without releasing the lock levers.
- (d) Optical connector can not be connected oppositely. Be sure the connector direction when connection is done.
- (e) Optical connector should be processed as follows before laying of optical fiber cable.
  - Fix a reinforcing cover to a wire with hook or tension member by a tape.

At laying hook the wire or pull the tension member taking enough care that optical connector does not receive pulling strength.

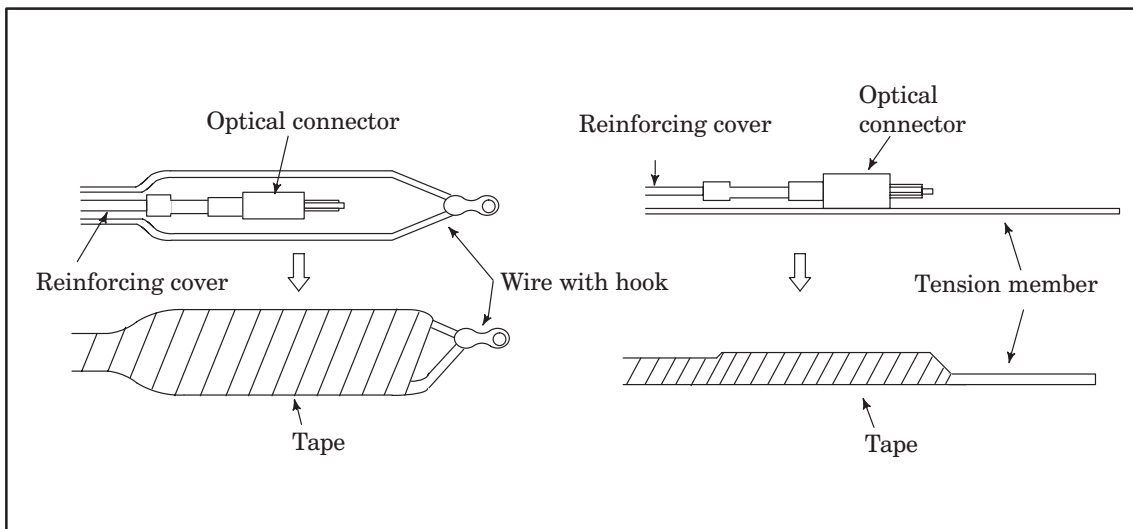

- (f) Reinforcing cover is fixed to cable lamp so that optical fiber cable could not weigh directly the connecting part of connector.
- (g) Notice that optical connector's chip is clear.
  - The attached protect cap must be always put on when optical connector is not used.
  - Remove dirty with a clear tissue or absorbent cotton (cotton with ethyle alcohol is applicable). No other organic solvent than ethyl alcohol can not be used.

4.3.4 Connection of I/O Unit—MODEL A

(1) Connection diagram

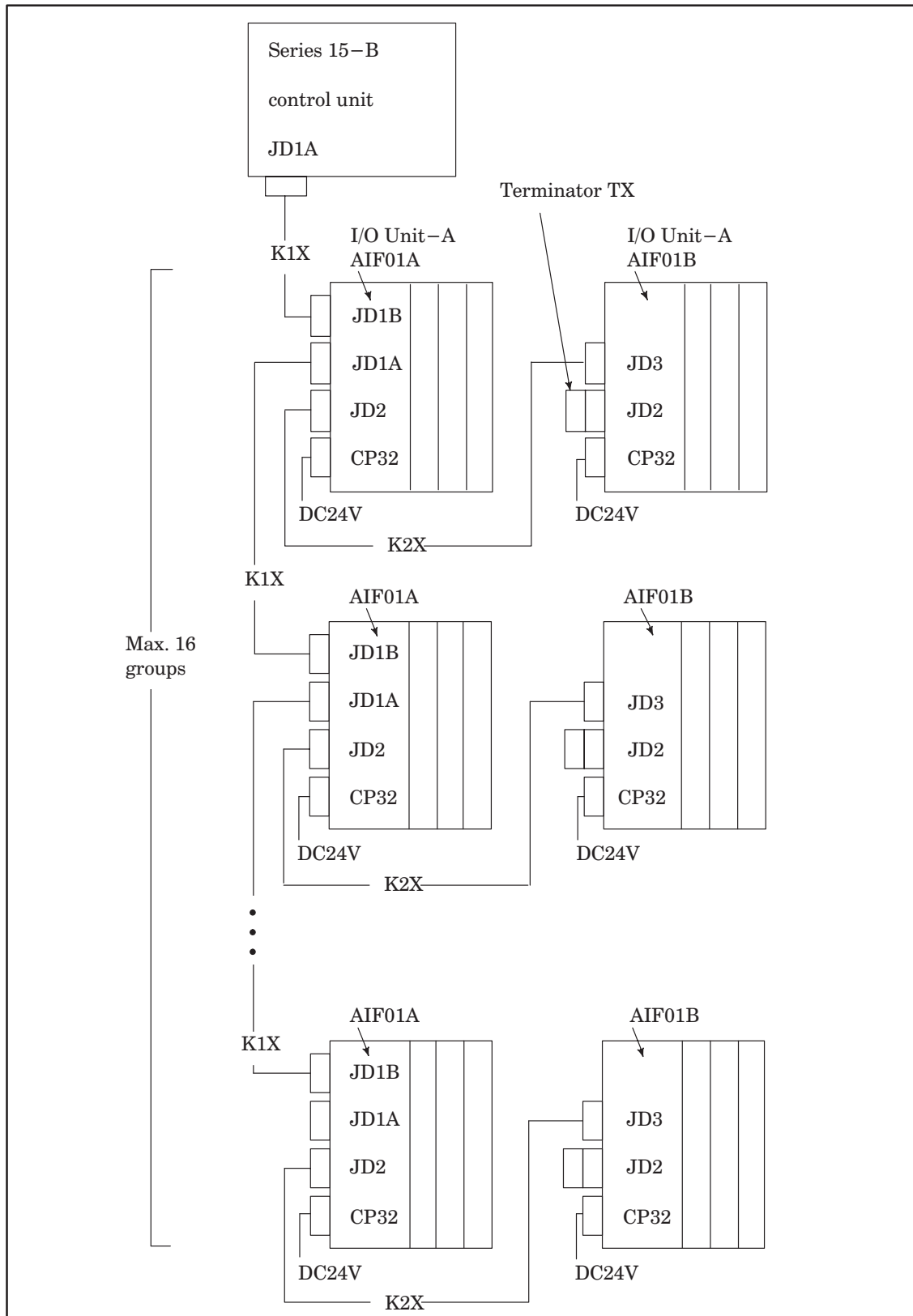

**NOTE 1** Number of I/O Units and connecting method are restricted depending on the allocation of the I/O points.

**NOTE 2** Cable K1X can be an optical fiber cable by using the Optical I/O link adapter.



(2) Connecting input power source

Connect the following power source to the connector CP32 of the interface module (AIF01A or AIF01B).

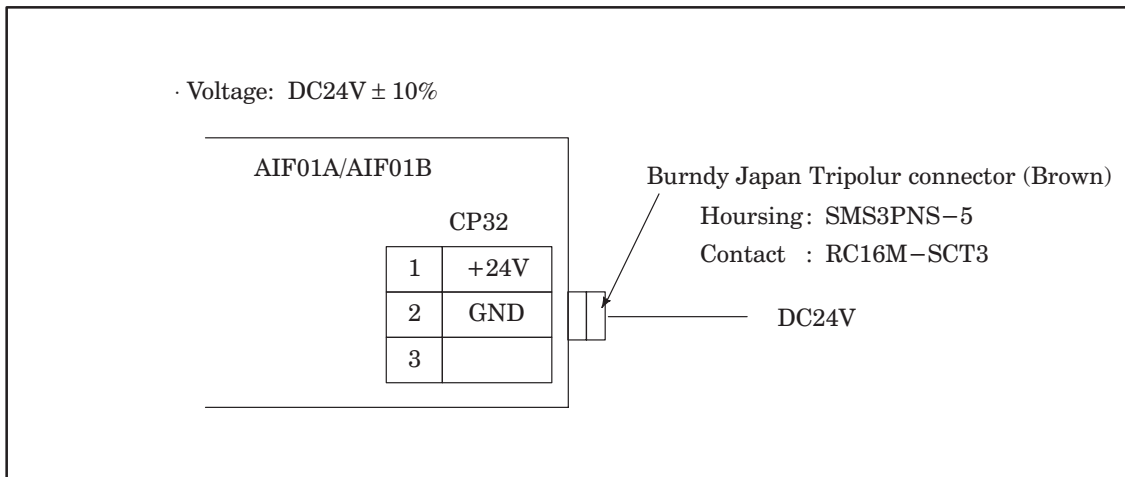

**NOTE** Turn ON the power for the I/O unit just when or before the power for the CNC is turned ON. When the CNC power is turned OFF, make sure to turn the power to the I/O unit OFF as well.

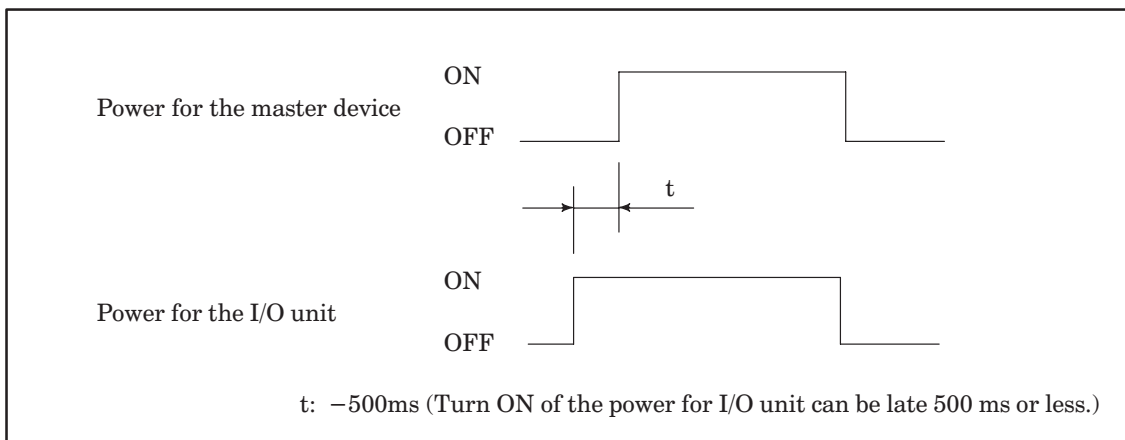

(3) Grounding

(a) Ground the base unit (ABU05A/B, ABU10A/B) by its grounding terminal

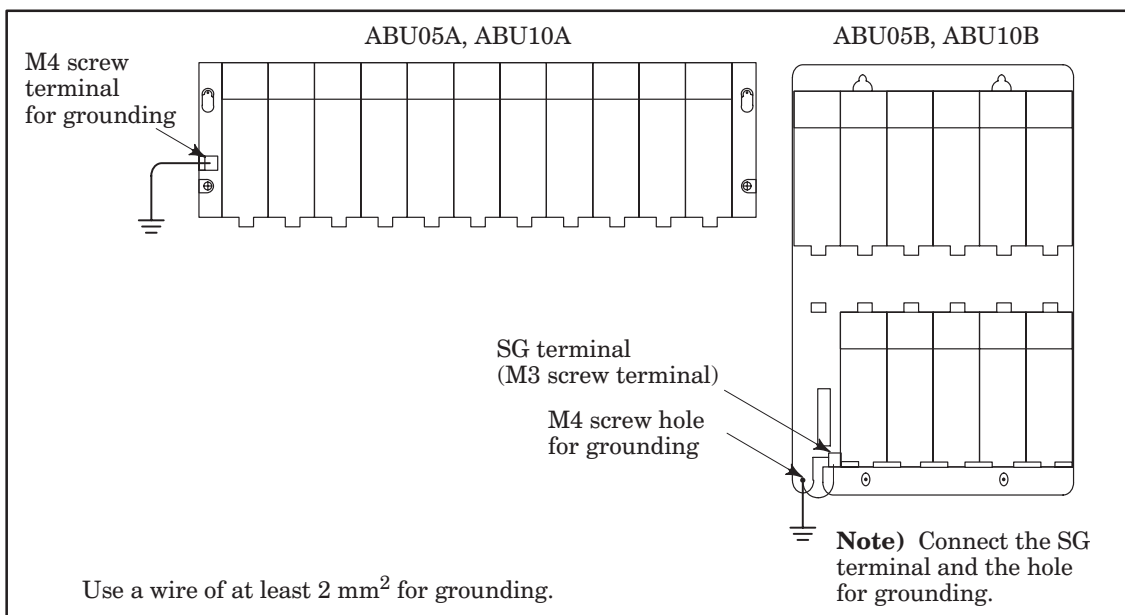

(b) When the cable K1X runs between different cabinets, make sure to connect the cabinets with a grounding wire more than 5.5 mm<sup>2</sup>.

(4) Connecting signal cables

Details of the cables K1X, K2X and the terminator shown in the general connection diagram are as follows.

(a) Cable K1X

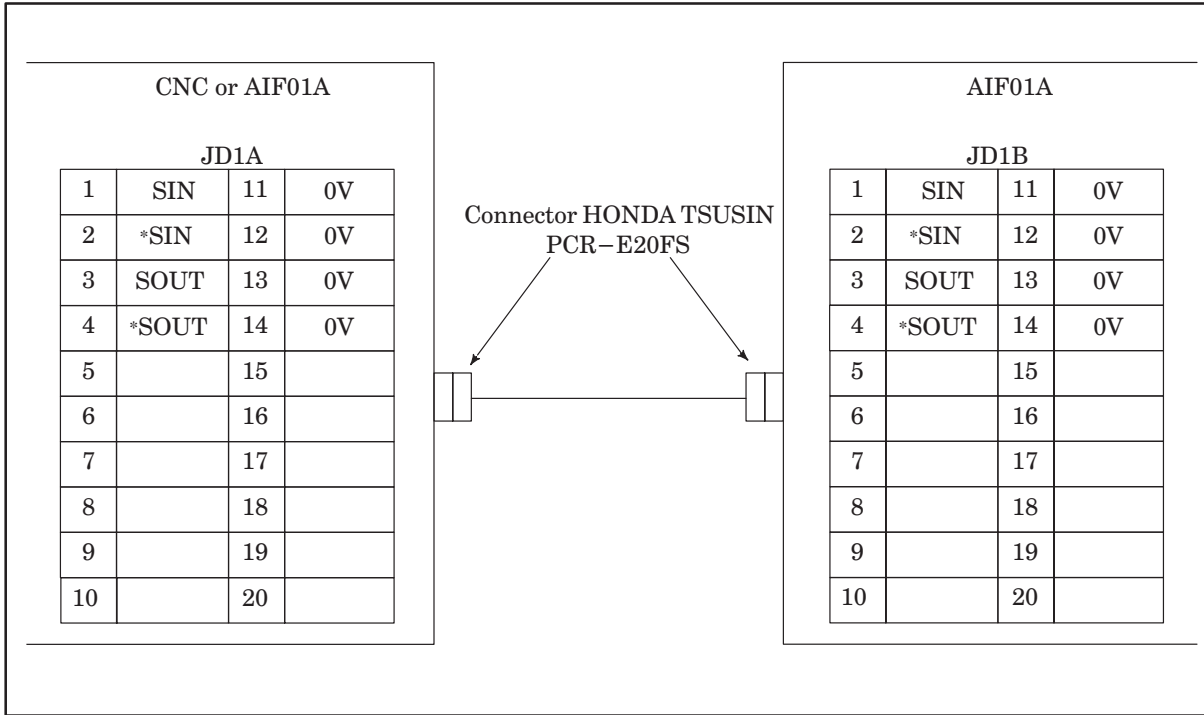

(b) Cable K2X

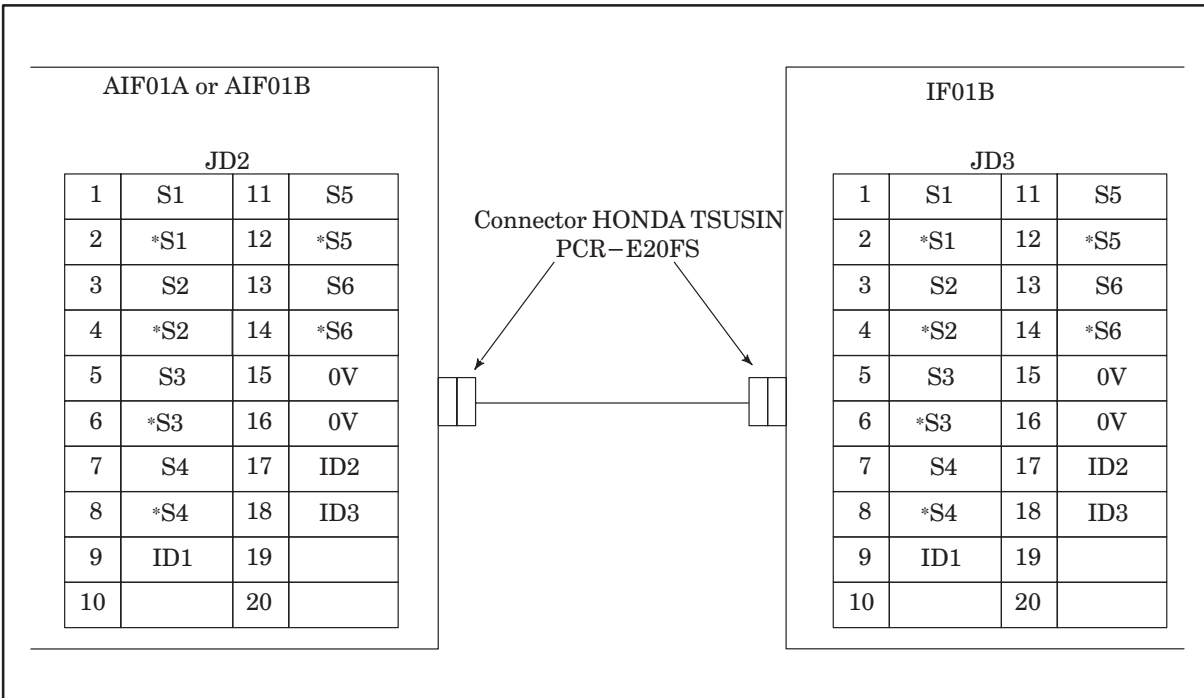

(c) Terminator TX

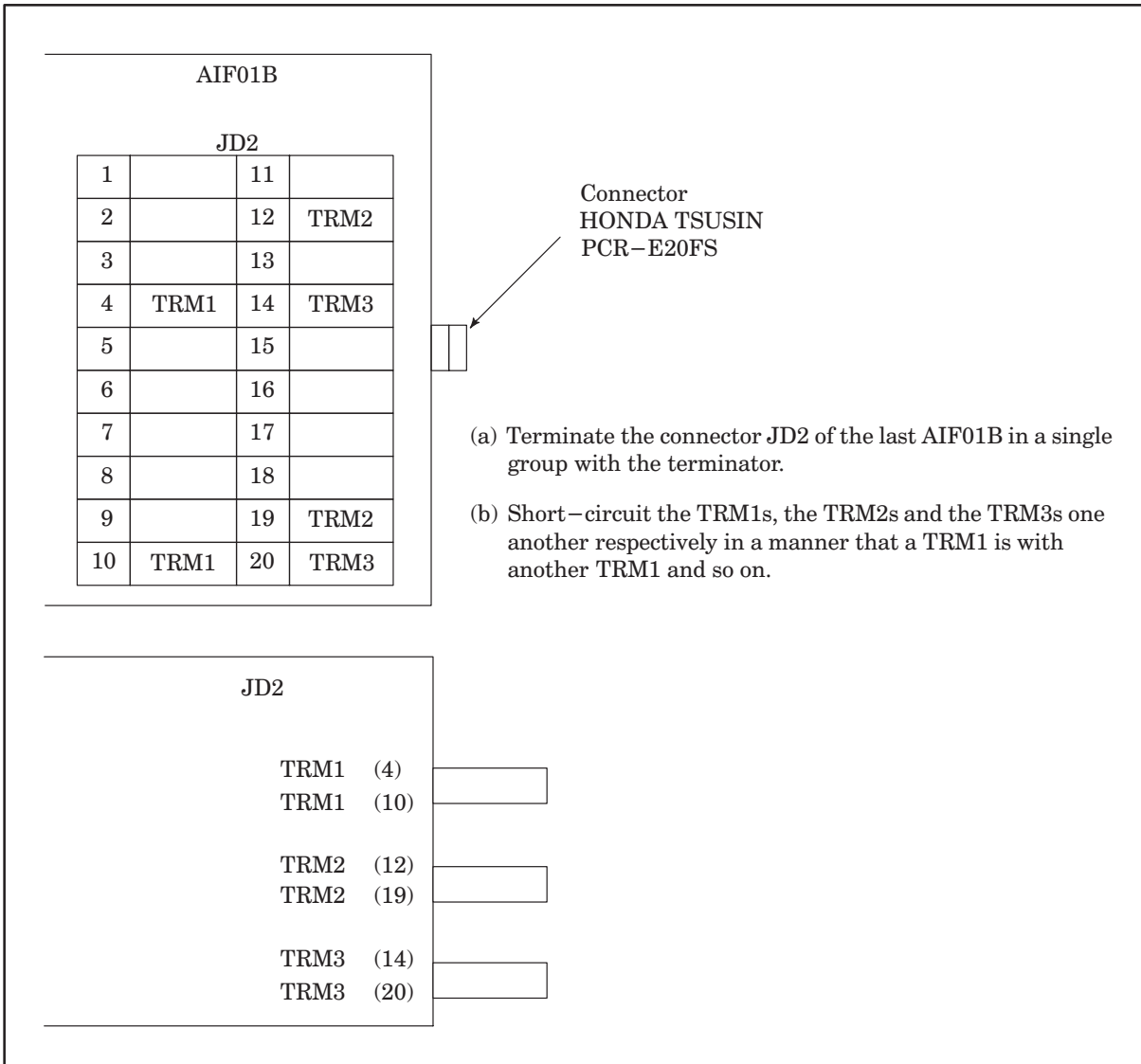

4.3.5 Connection with Connection unit

(1) Connection diagram

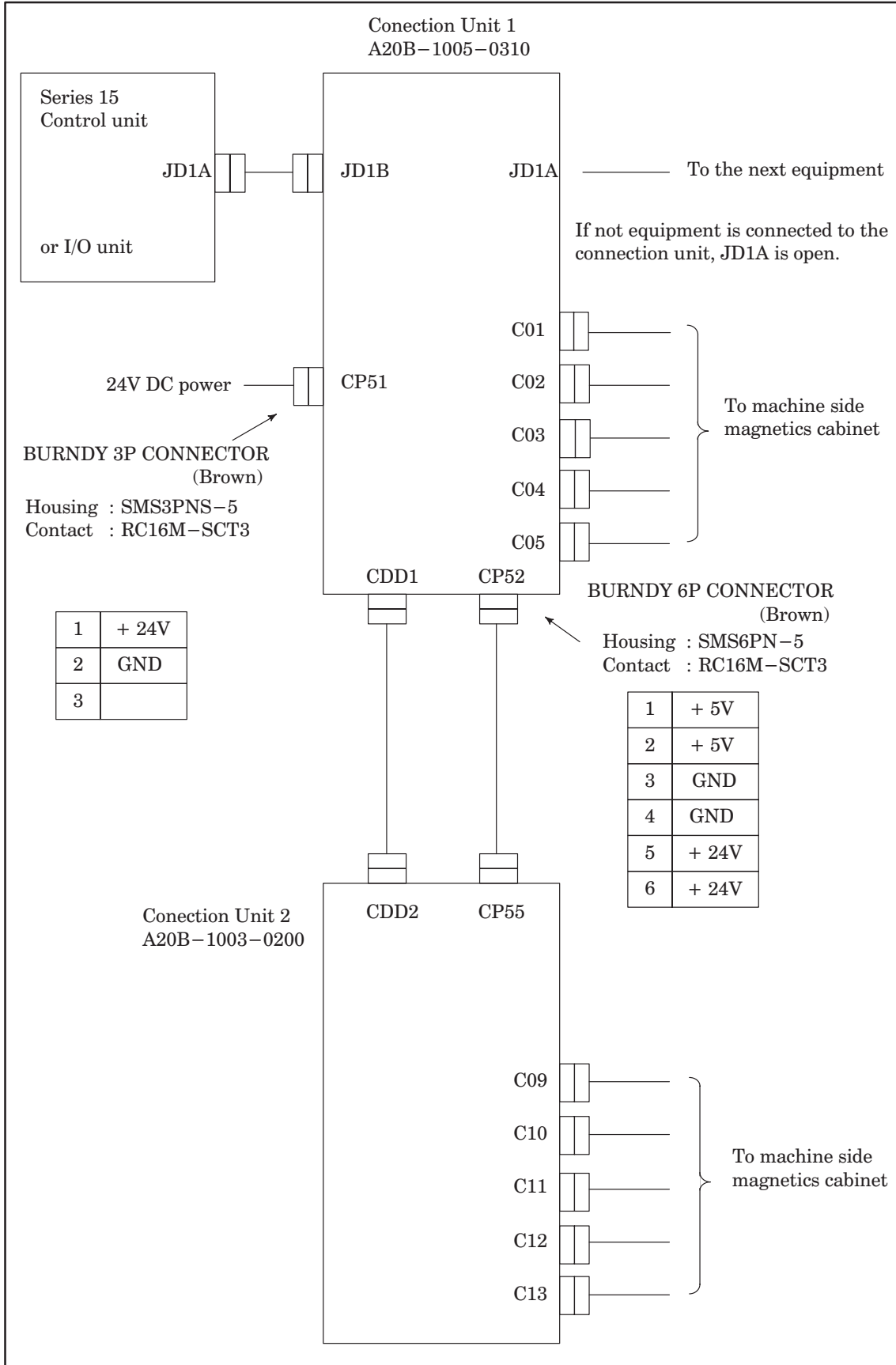

4.3.6 Connection of operator's panel connection unit

(1) Connection diagram

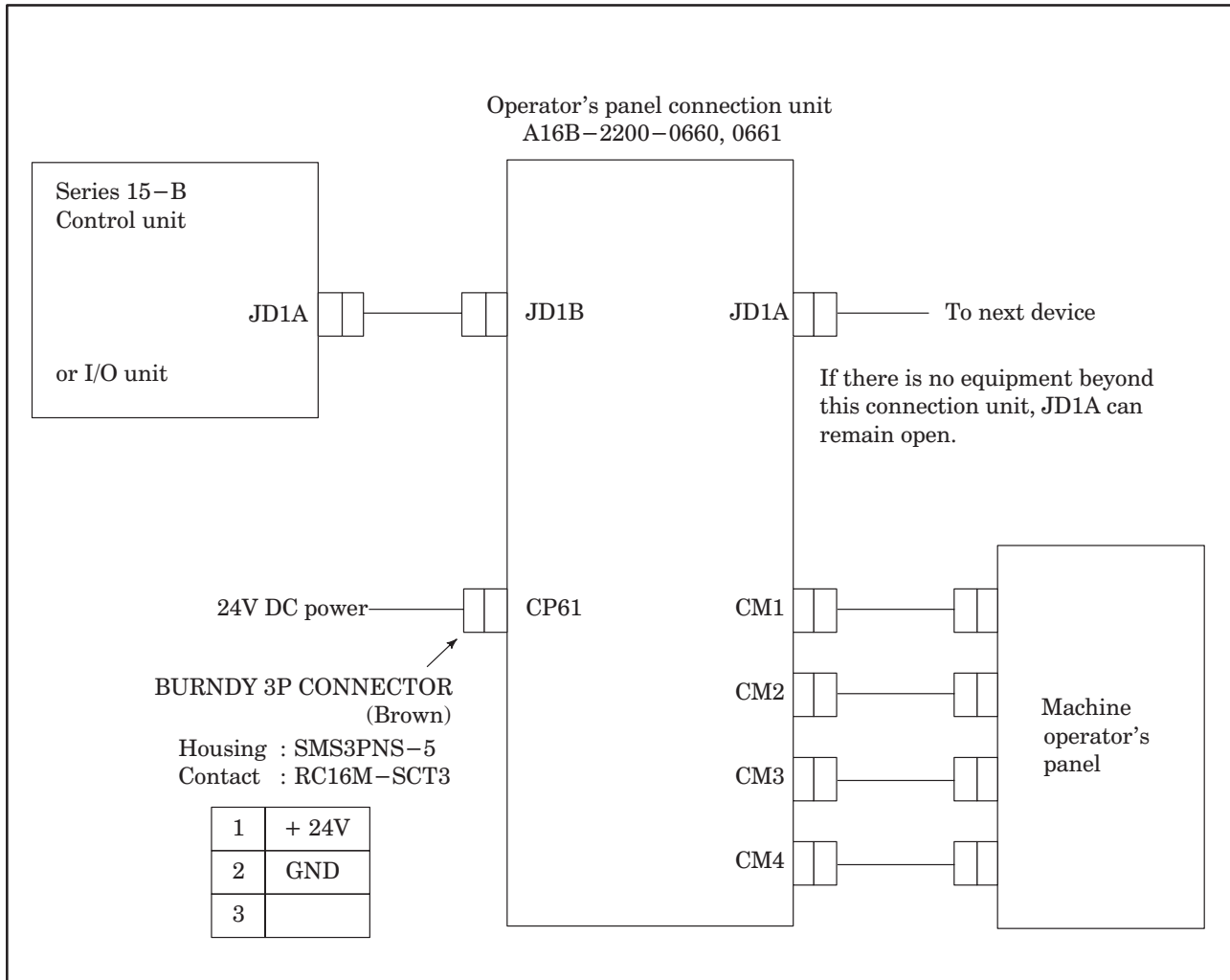

(2) Connector layout for operator's panel connection unit

CM1

1	DI00		33		
2	DI03		34	DI02	
3	DI06	19	DI01	35	DI05
4	DI11	20	DI04	36	DI10
5	DI14	21	DI07	37	DI13
6	DI17	22	DI12	38	DI16
7	DI22	23	DI15	39	DI21
8	DI25	24	DI20	40	DI24
9	DI27	25	DI23	41	DI26
10	DI32	26	DI30	42	DI31
11	DI35	27	DI33	43	DI34
12	DI40	28	DI36	44	DI37
13	DI43	29	DI41	45	DI42
14	DI46	30	DI44	46	DI45
15	DI51	31	DI47	47	DI50
16	DI54	32	DI52	48	DI53
17	DI56			49	DI55
18	COM1			50	DI57

Address	7	6	5	4	3	2	1	0
X <sub>n</sub>	DI07	DI06	DI05	DI04	DI03	DI02	DI01	DI00
X <sub>n+1</sub>	DI17	DI16	DI15	DI14	DI13	DI12	DI11	DI10
X <sub>n+2</sub>	DI27	DI26	DI25	DI24	DI23	DI22	DI21	DI20
X <sub>n+3</sub>	DI37	DI36	DI35	DI34	DI33	DI32	DI31	DI30
X <sub>n+4</sub>	DI47	DI46	DI45	DI44	DI43	DI42	DI41	DI40
X <sub>n+5</sub>	DI57	DI56	DI55	DI54	DI53	DI52	DI51	DI50

CM2

1	DI60		33		
2	DI63		34	DI62	
3	DI66	19	DI61	35	DI65
4	DI71	20	DI64	36	DI70
5	DI74	21	DI67	37	DI73
6	DI77	22	DI72	38	DI76
7	DI82	23	DI75	39	DI81
8	DI85	24	DI80	40	DI84
9	DI87	25	DI83	41	DI86
10	DI92	26	DI90	42	DI91
11	DI95	27	DI93	43	DI94
12	DIA0	28	DI96	44	DI97
13	DIA3	29	DIA1	45	DIA2
14	DIA6	30	DIA4	46	DIA5
15	DIB1	31	DIA7	47	DIB0
16	DIB4	32	DIB2	48	DIB3
17	DIB6			49	DIB5
18	COM2			50	DIB7

X <sub>n+6</sub>	DI67	DI66	DI65	DI64	DI63	DI62	DI61	DI60
X <sub>n+7</sub>	DI77	DI76	DI75	DI74	DI73	DI72	DI71	DI70
X <sub>n+8</sub>	DI87	DI86	DI85	DI84	DI83	DI82	DI81	DI80
X <sub>n+9</sub>	DI97	DI96	DI95	DI94	DI93	DI92	DI91	DI90
X <sub>n+10</sub>	DIA7	DIA6	DIA5	DIA4	DIA3	DIA2	DIA1	DIA0
X <sub>n+11</sub>	DIB7	DIB6	DIB5	DIB4	DIB3	DIB2	DIB1	DIB0

**NOTE** Address No. n can be decided by machine tool builders.

## CM3

1	DO00		33	+5N	
2	DO03		34	DO02	
3	DO06	19	DO01	35	DO05
4	DO11	20	DO04	36	DO10
5	DO14	21	DO07	37	DO13
6	DO17	22	DO12	38	DO16
7	DO22	23	DO15	39	DO21
8	DO25	24	DO20	40	DO24
9	DO27	25	DO23	41	DO26
10	DO32	26	DO30	42	DO31
11	DO35	27	DO33	43	DO34
12	DO40	28	DO36	44	DO37
13	DO43	29	DO41	45	DO42
14	DO46	30	DO44	46	DO45
15	DO51	31	DO47	47	DO50
16	DO54	32	DO52	48	DO53
17	DO56			49	DO55
18	COM3			50	DO57

Address	7	6	5	4	3	2	1	0
Y <sub>n</sub>	DO07	DO06	DO05	DO04	DO03	DO02	DO01	DO00
Y <sub>n+1</sub>	DO17	DO16	DO15	DO14	DO13	DO12	DO11	DO10
Y <sub>n+2</sub>	DO27	DO26	DO25	DO24	DO23	DO22	DO21	DO20
Y <sub>n+3</sub>	DO37	DO36	DO35	DO34	DO33	DO32	DO31	DO30
Y <sub>n+4</sub>	DO47	DO46	DO45	DO44	DO43	DO42	DO41	DO40
Y <sub>n+5</sub>	DO57	DO56	DO55	DO54	DO53	DO52	DO51	DO50

## CM4

1	DO61		14	DO60	
2	DO64	8	DO62	15	DO63
3	DO67	9	DO65	16	DO66
4	DO72	10	DO70	17	DO71
5	DO75	11	DO73	18	DO74
6		12	DO76	19	DO77
7	COM4	13		20	

Y <sub>n+6</sub>	DO67	DO66	DO65	DO64	DO63	DO62	DO61	DO60
Y <sub>n+7</sub>	DO77	DO76	DO75	DO74	DO73	DO72	DO71	DO70

**NOTE** Address No. n can be decided by machine tool builders.

4.3.7 CRT display interface

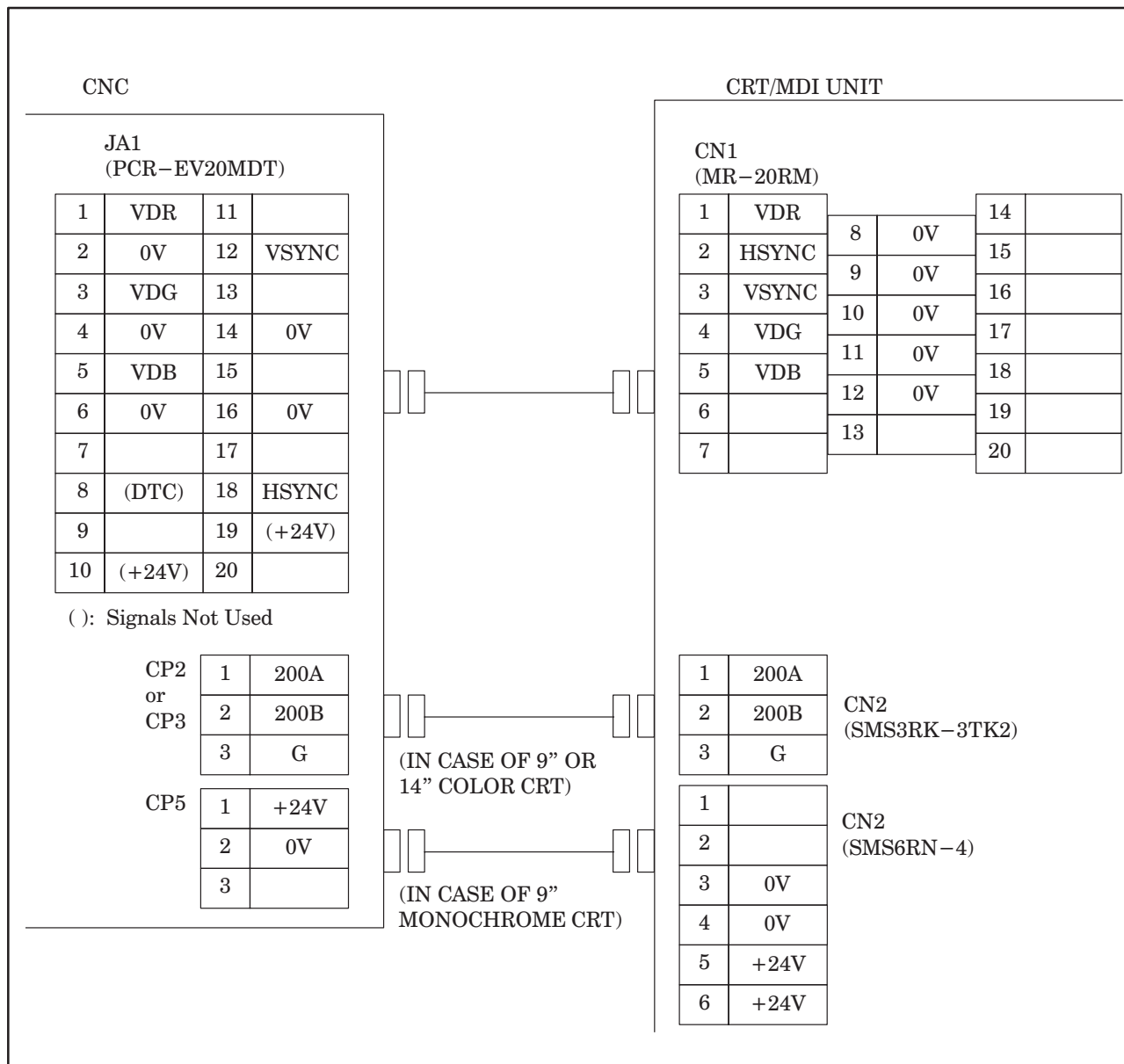



## 4.3.8 LCD-PDP display interface

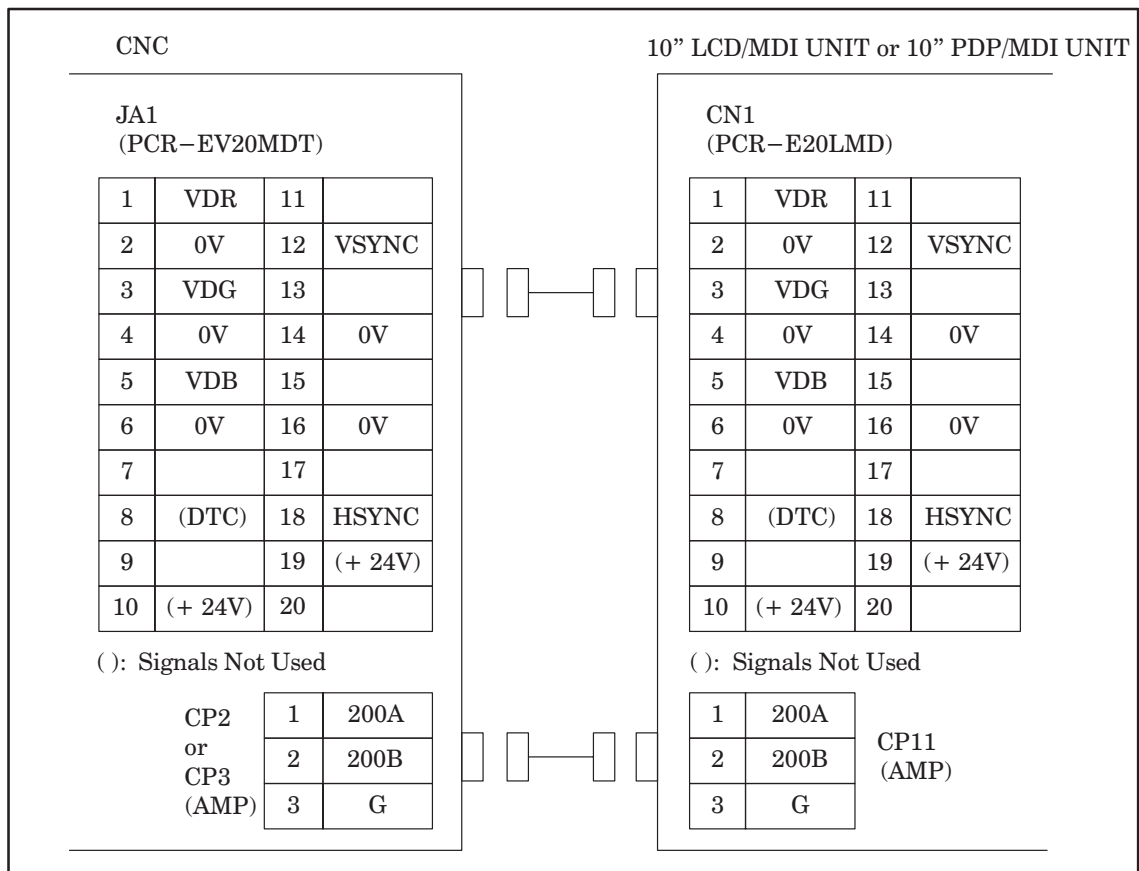

## 4.3.9 Keyboard interface

The keyboard interface specification is common to all Series 15-B MDI units.

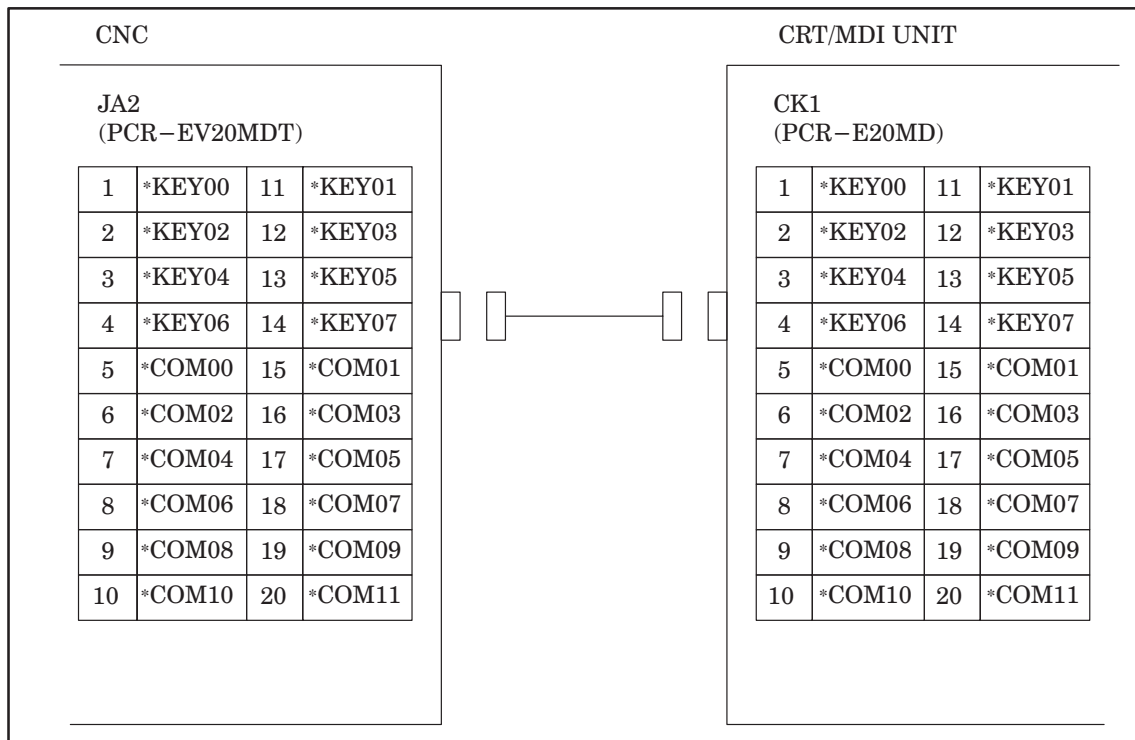

4.3.10 Manual pulse generator interface

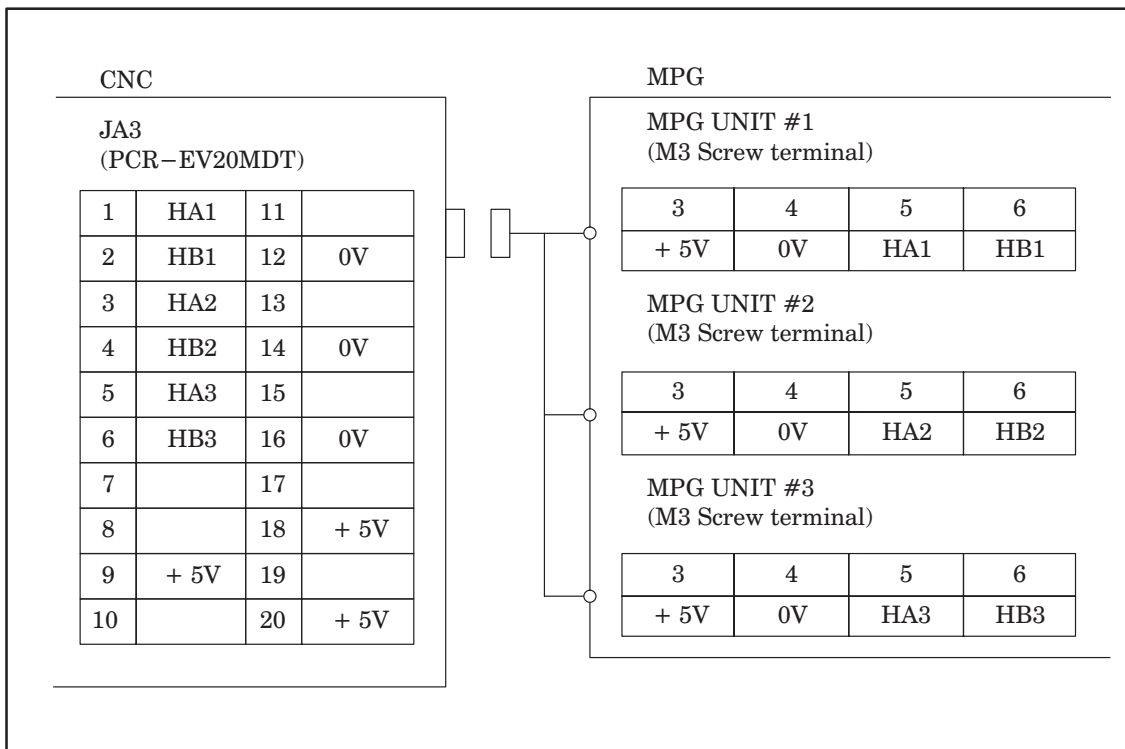

4.3.11 Remote buffer interface (RS-232-C)

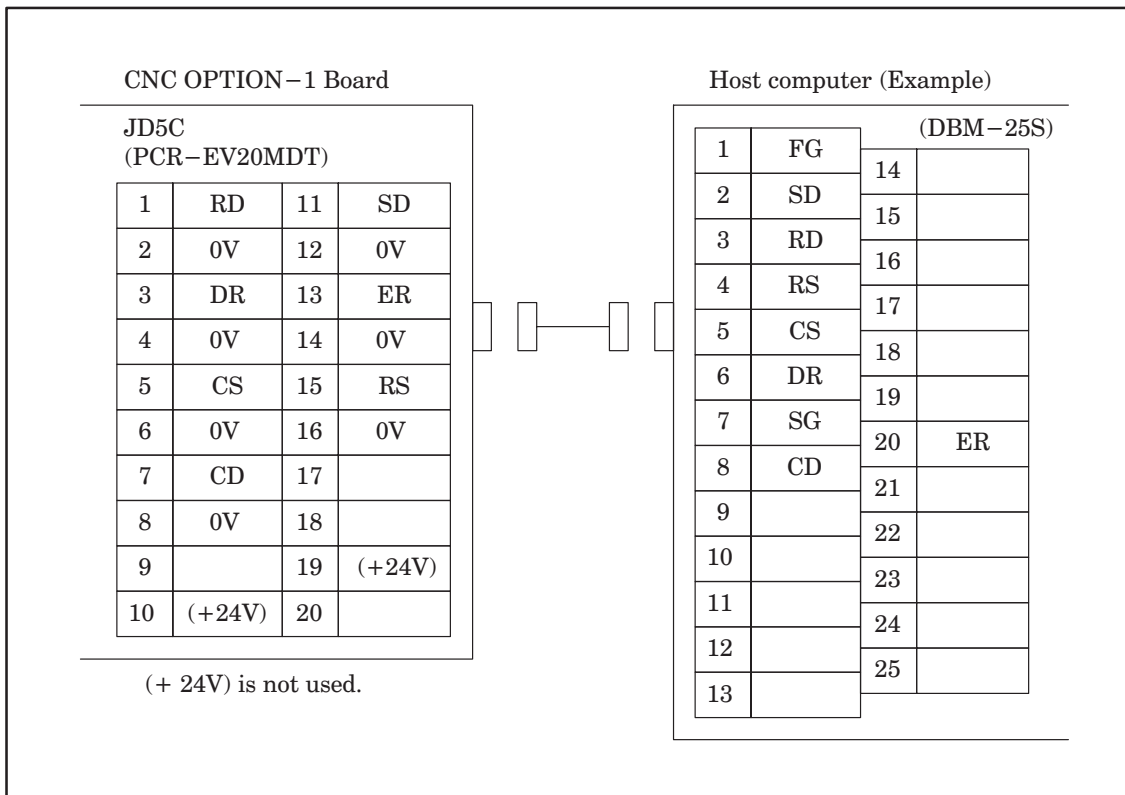

4.3.12 Remote buffer interface (RS-422)

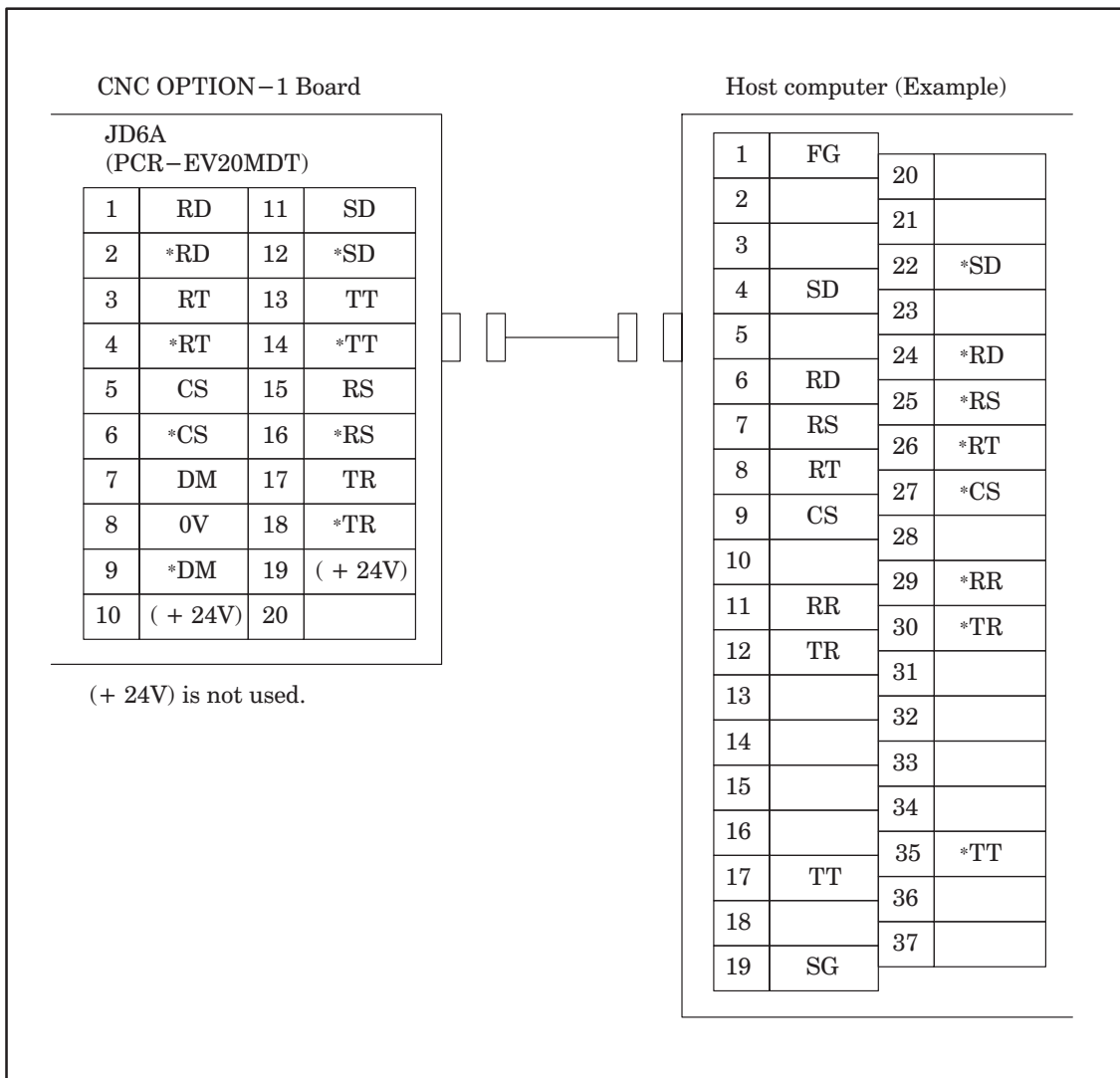

### 4.4 Confirmation of Connection between CNC Control Unit and Servo

Servo interface of Series15-B has following features.

- Digital control AC servo motor
- Motor feedback : Serial pulsecoder
  - 1) 40,000 pulse/rev incremental pulsecoder
  - 2) 1,000,000 pulse/rev absolute pulsecoder
- Scale feedback : A/B/Z signal interface

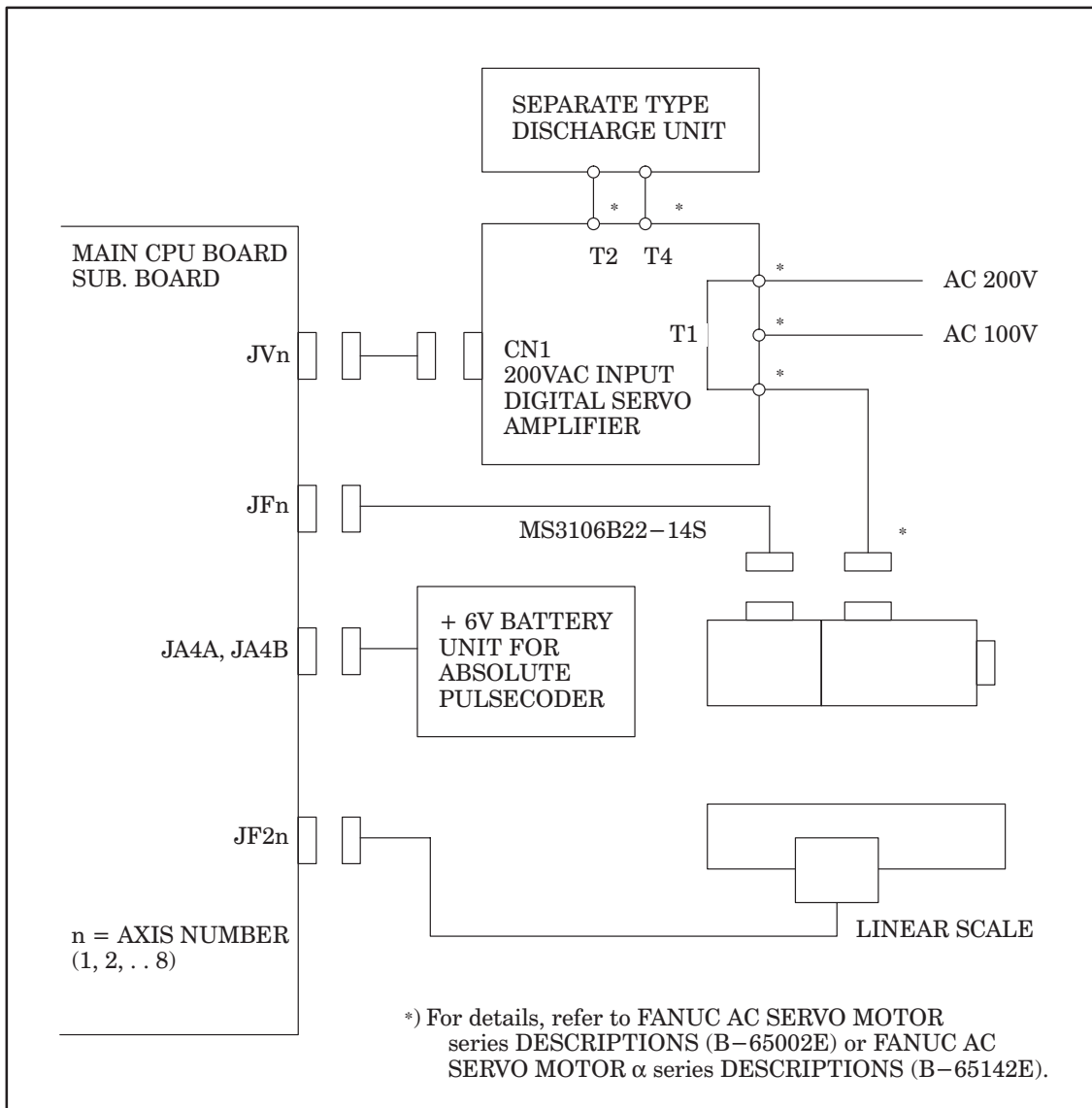

(1) Servo amp interface

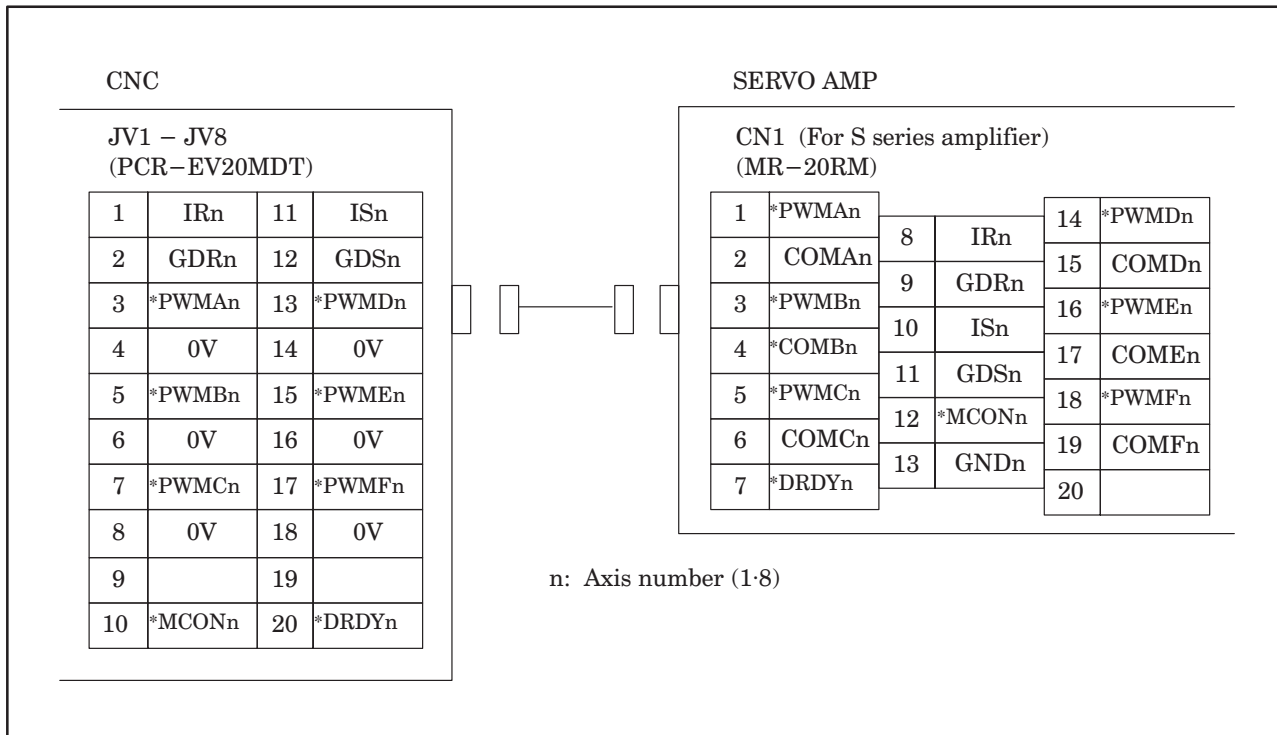

(2) Serial pulsecoder interface

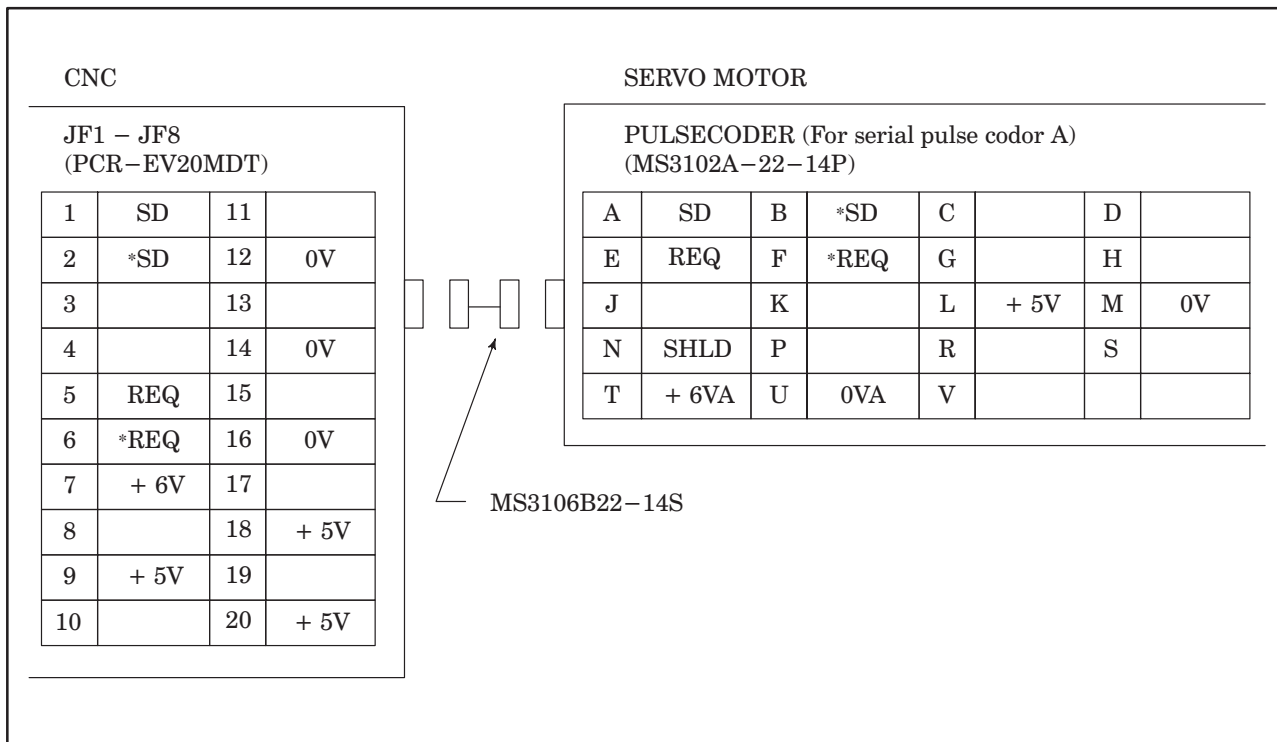

(3) Linear scale interface

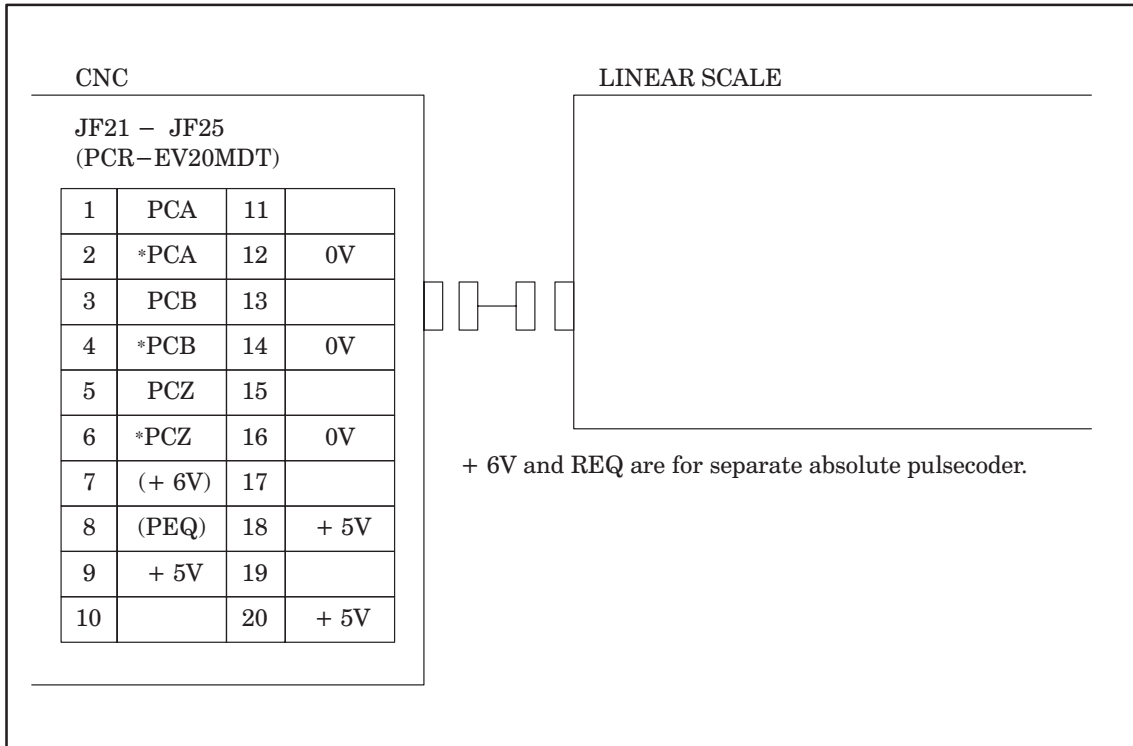

(4) APC battery interface

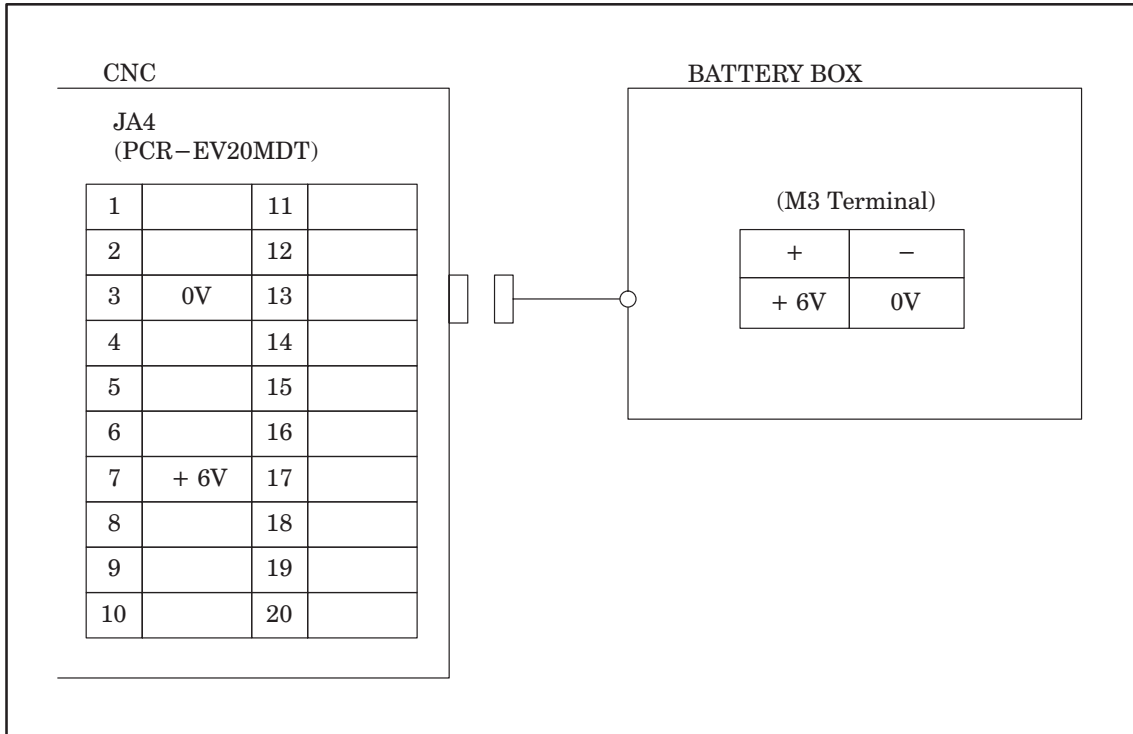

Connecting a motor normally or in reverse (relationships between the connection and direction of rotation)  
The following explains connection of a motor to rotate in the direction of B in the figure with a command in which a positive value is specified.

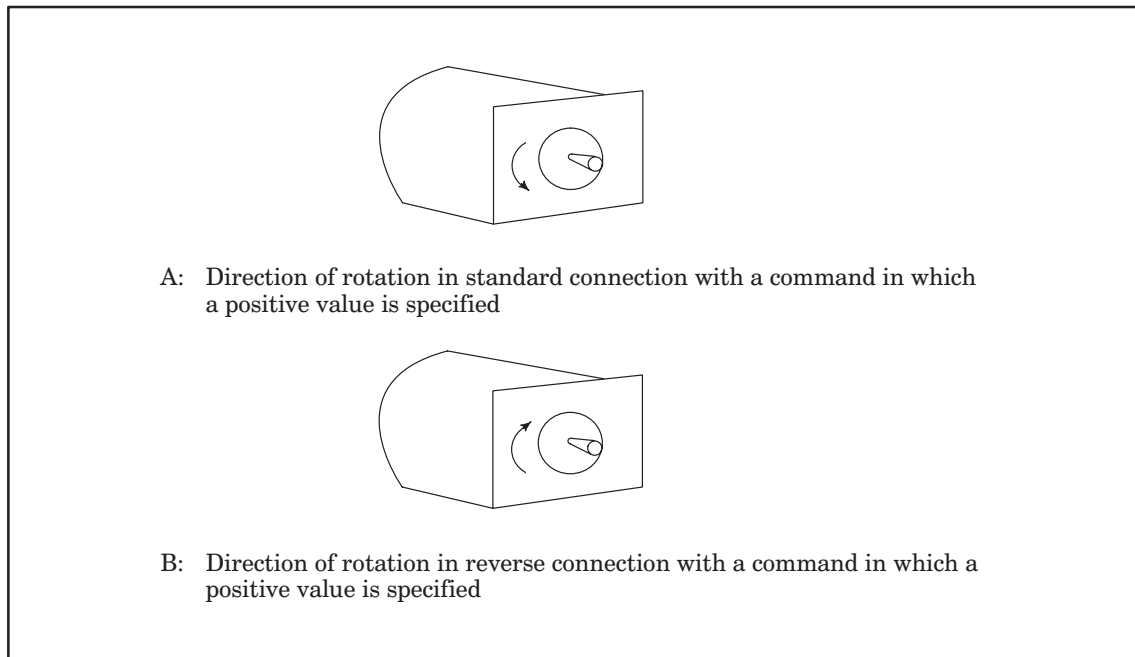

**Fig. 4.4.3 Servo motor connection and direction of rotation**

(1) For a built-in pulse coder

For a digital servo, the cables does not need to be exchanged because the direction can be changed using parameter No. 1879.

(2) When a separate pulse coder or linear scale is used

When the motor is to rotate in the direction opposite to that specified in a command for a digital servo, the direction can be changed using parameter No. 1879.

When the motor rotates in the direction opposite to that of a separate pulse coder, exchange the cables of the separate pulse coder as follows.

For a linear scale, the same operation is required. If a delay occurs between the PCB feedback signal and PCA phase for a command to rotate the motor in the forward direction, perform operations (a) and (b).

- (a) Exchange the PCA signal with the PCB signal.
- (b) Exchange the \*PCA signal with the \*PCB signal.

### 4.5 Confirming the Connection between the CNC Control Unit and Spindle Motor

(1) Serial Spindle Interface

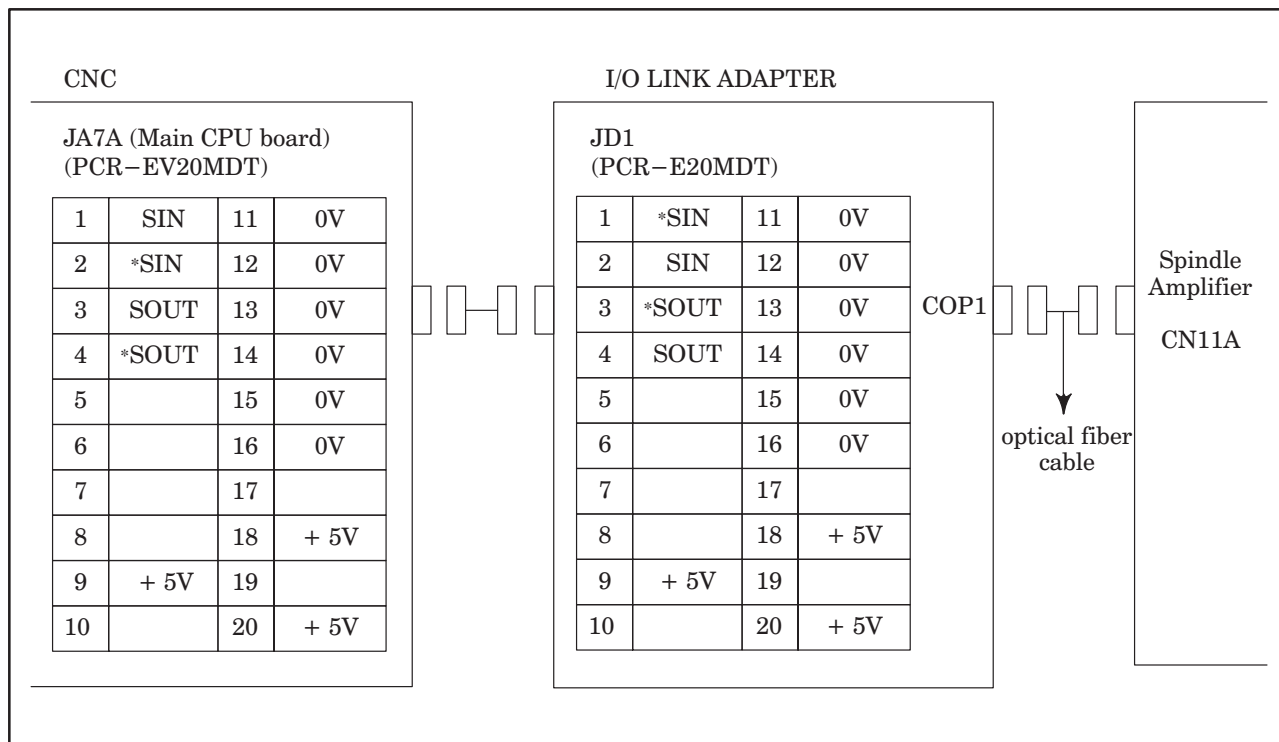



## (2) Analog Spindle Interface

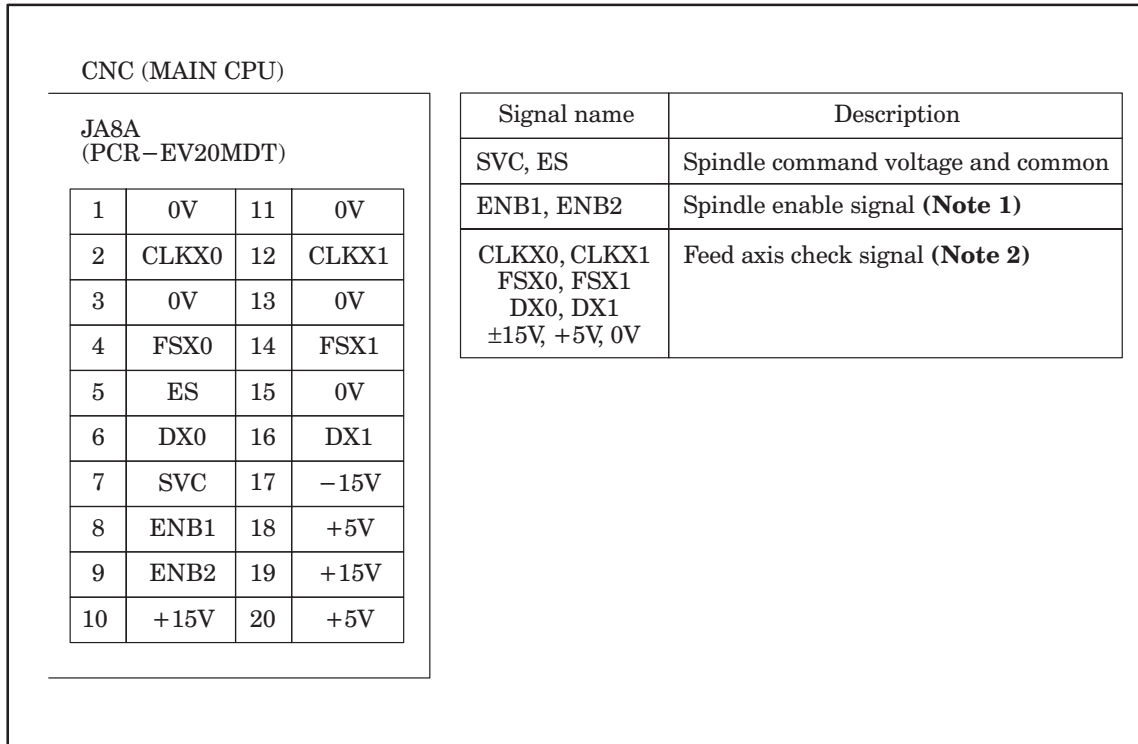

## CABLE WIRING

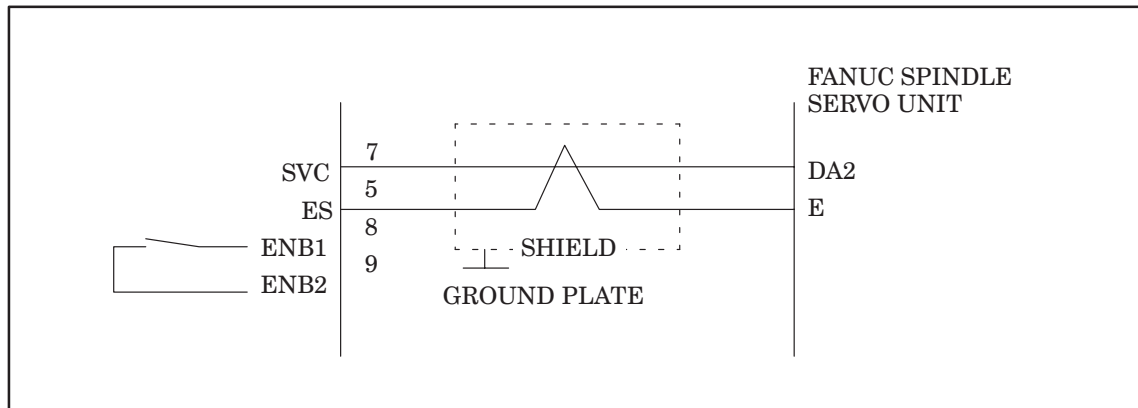

**NOTE 1** ENB1 and 2 turn on when a spindle command voltage is effective. These signals are not used when FANUC Spindle Servo Unit is used.

**NOTE 2** Feed axis check signal is used when a feed axis is checked or a service work is done. This signal is not used for spindle control.

(3) Position Coder Interface

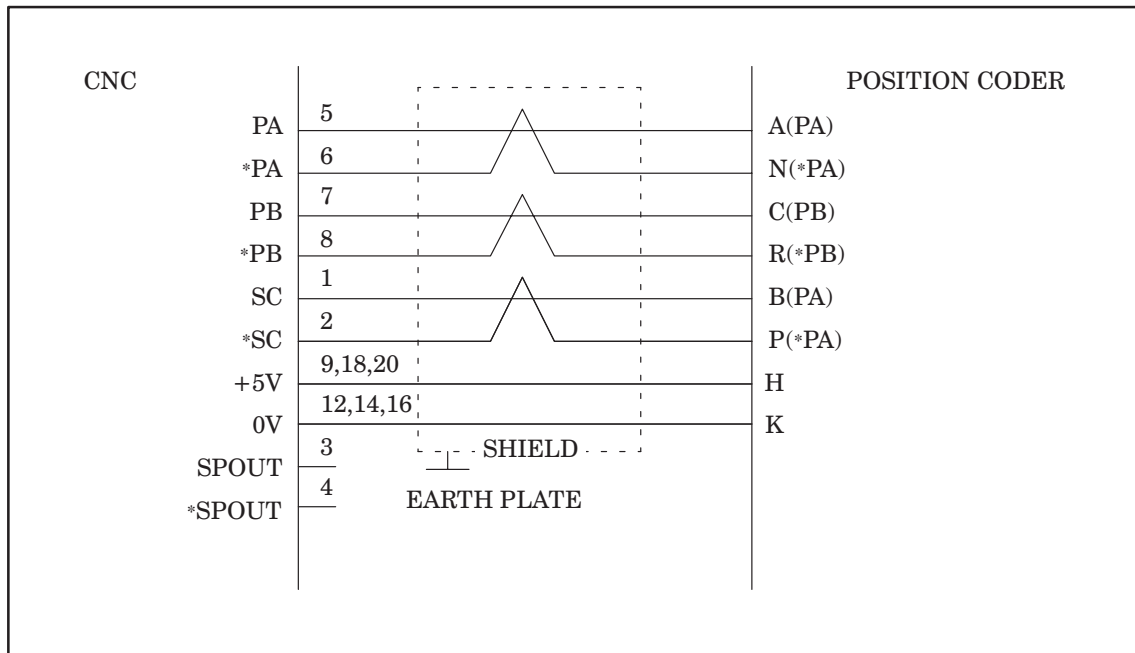
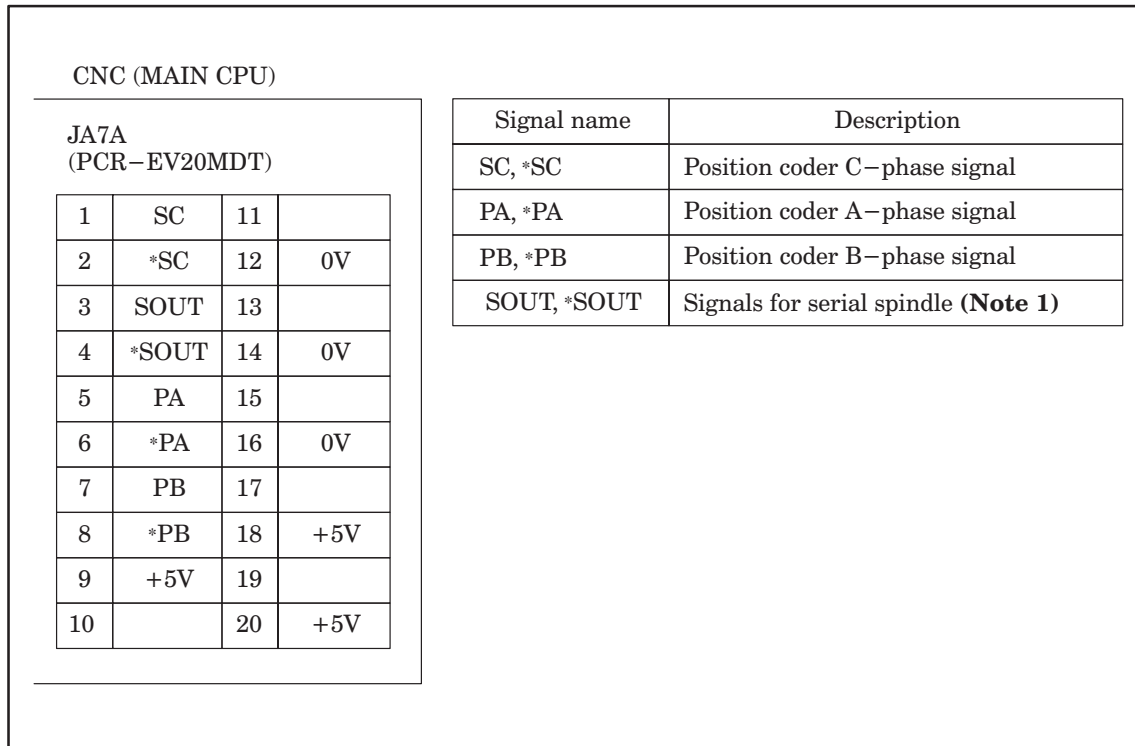

Recommended cable

A66L-0001-0286 (#20AWG×6+#24AWG×3) MAX LENGTH 20m.

**NOTE 1** Signals SPOUT and \*SPOUT are for serial spindle. These signals are not used for Analog spindle.

### 4.6 Confirming the Connection between the NC Control Unit and I/O devices

#### 4.6.1 RS-232-C serial port

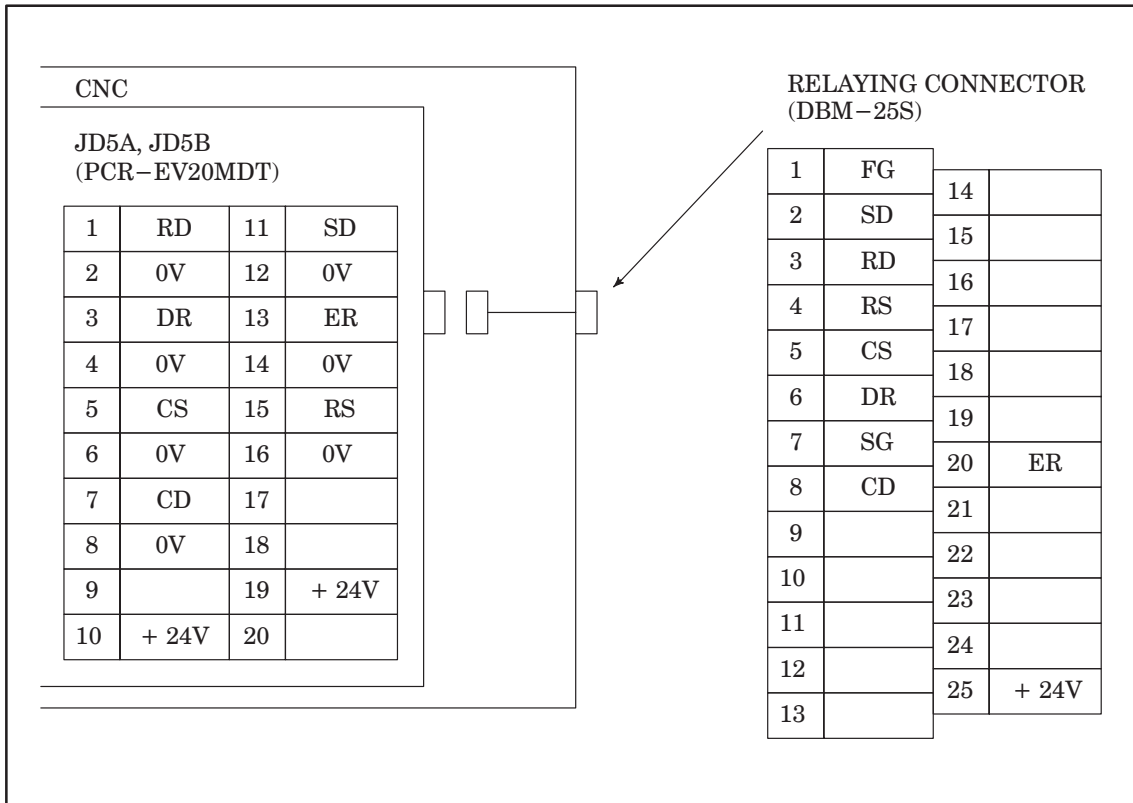

4.6.2 PPR connection

RELAYING CONNECTOR SIGNAL LAYOUT

1	2	3	4	5	6	7	8	9	10	11	12	13
FG	SD	RD	RS	CS	DR	SG	CD					
14	15	16	17	18	19	20	21	22	23	24	25	
						ER					+24V	

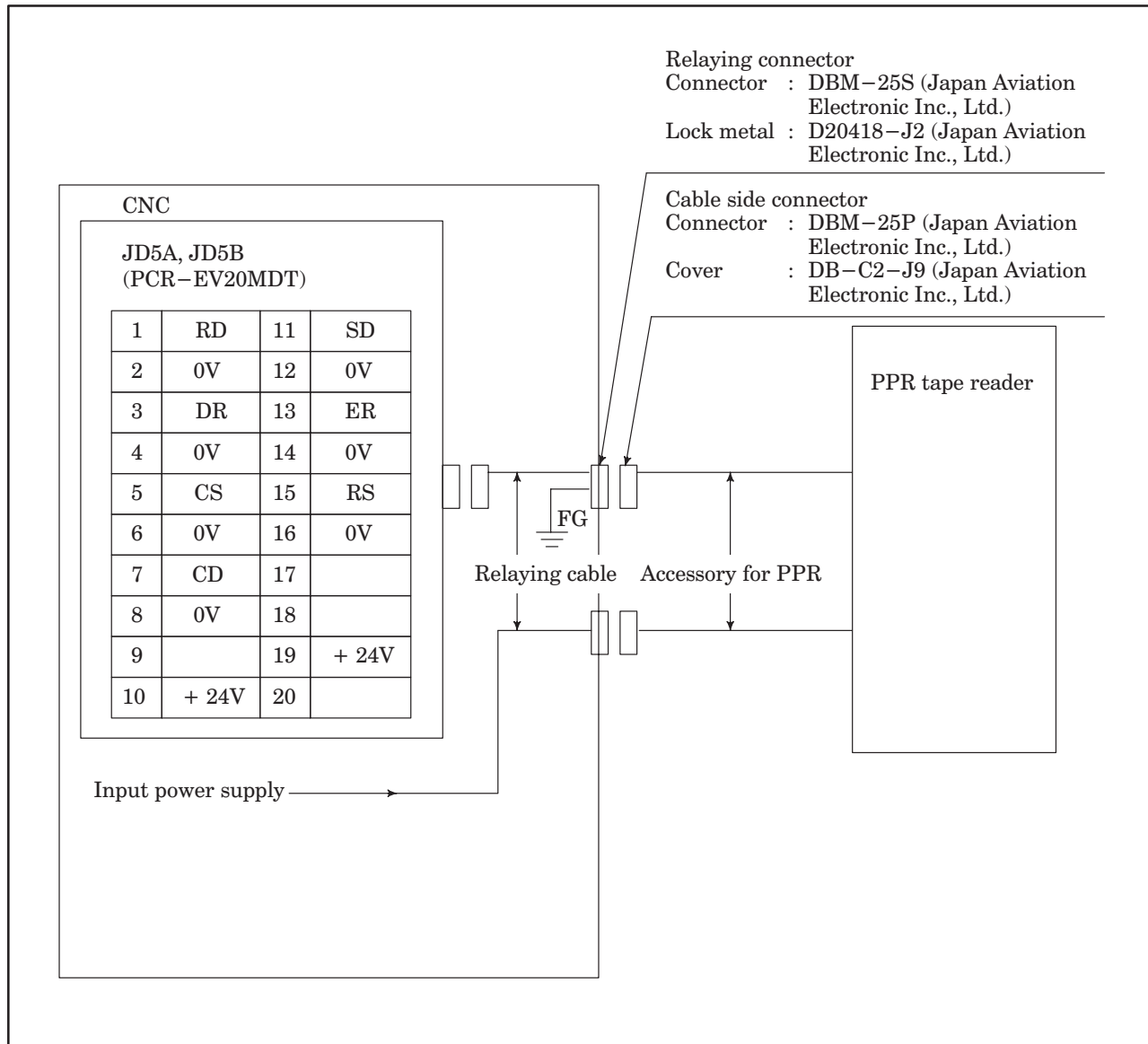

4.6.3 Portable tape reader connection

RELAYING CONNECTOR SIGNAL LAYOUT

1	2	3	4	5	6	7	8	9	10	11	12	13
FG	SD	RD	RS	CS	DR	SG	CD					
14	15	16	17	18	19	20	21	22	23	24	25	
						ER					+24V	

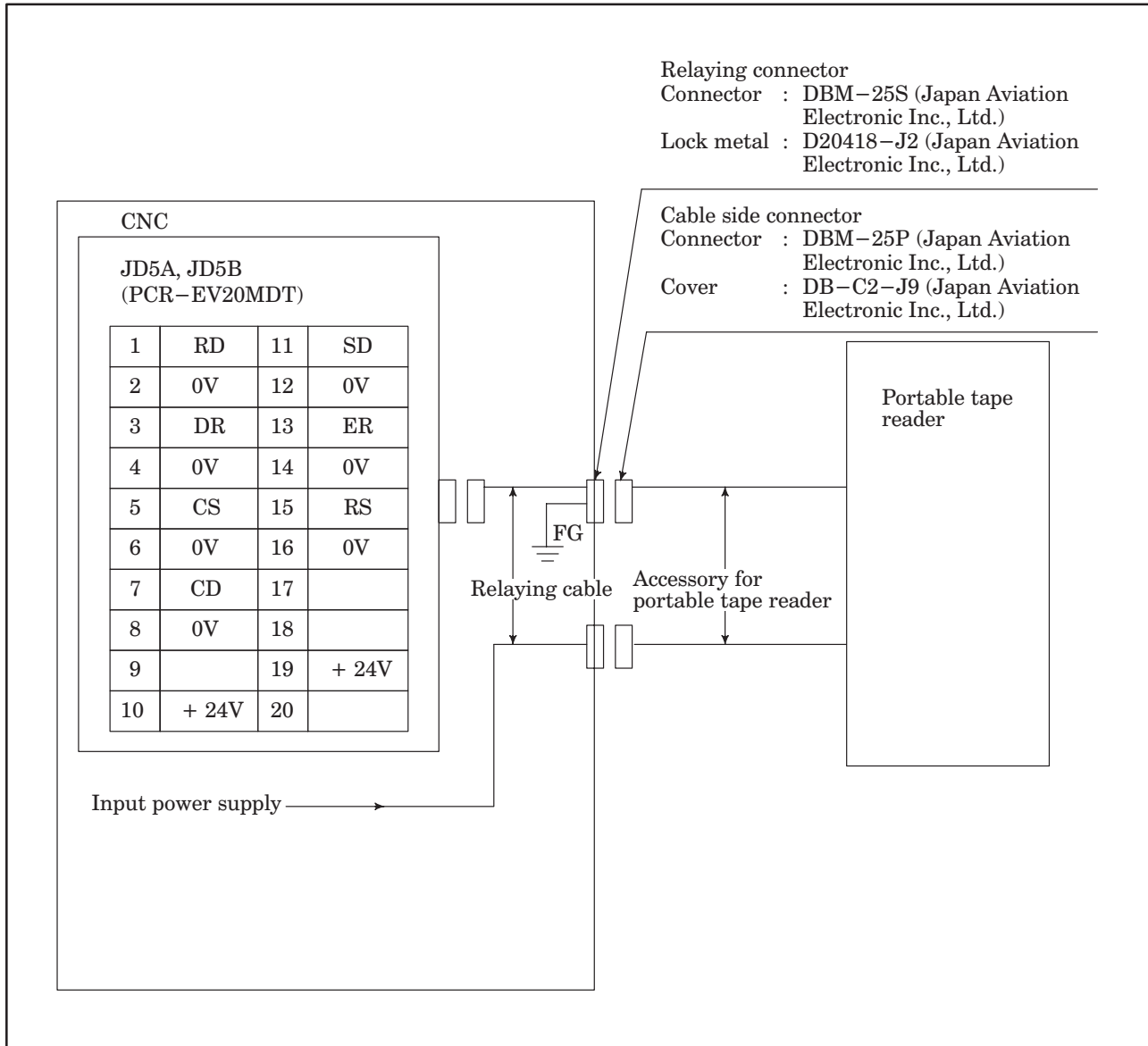

4.6.4 FANUC Cassette connection

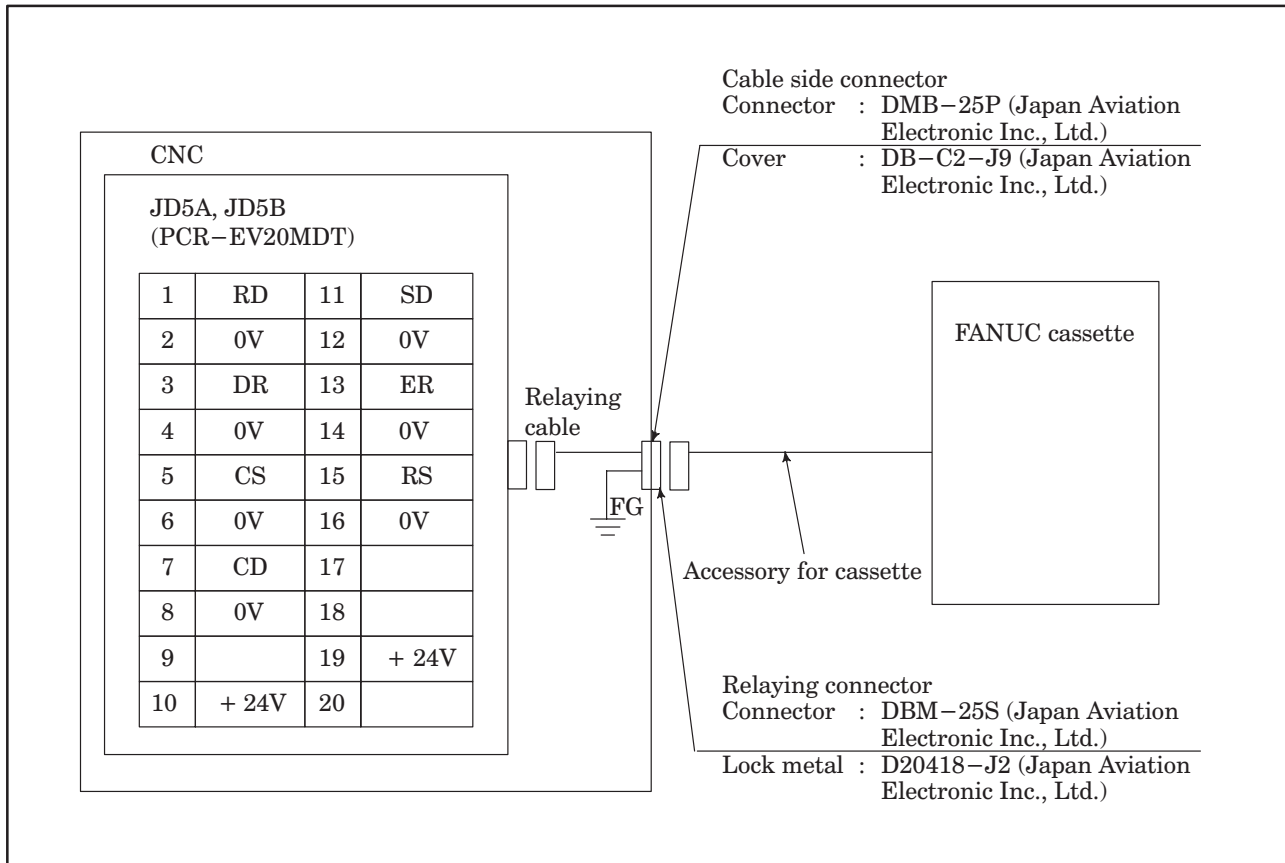

RELAYING CONNECTOR SIGNAL LAYOUT

1	2	3	4	5	6	7	8	9	10	11	12	13
FG	SD	RD	RS	CS	DR	SG	CD					
14	15	16	17	18	19	20	21	22	23	24	25	
						ER					+24V	

4.6.5 Connection of tape reader without reels

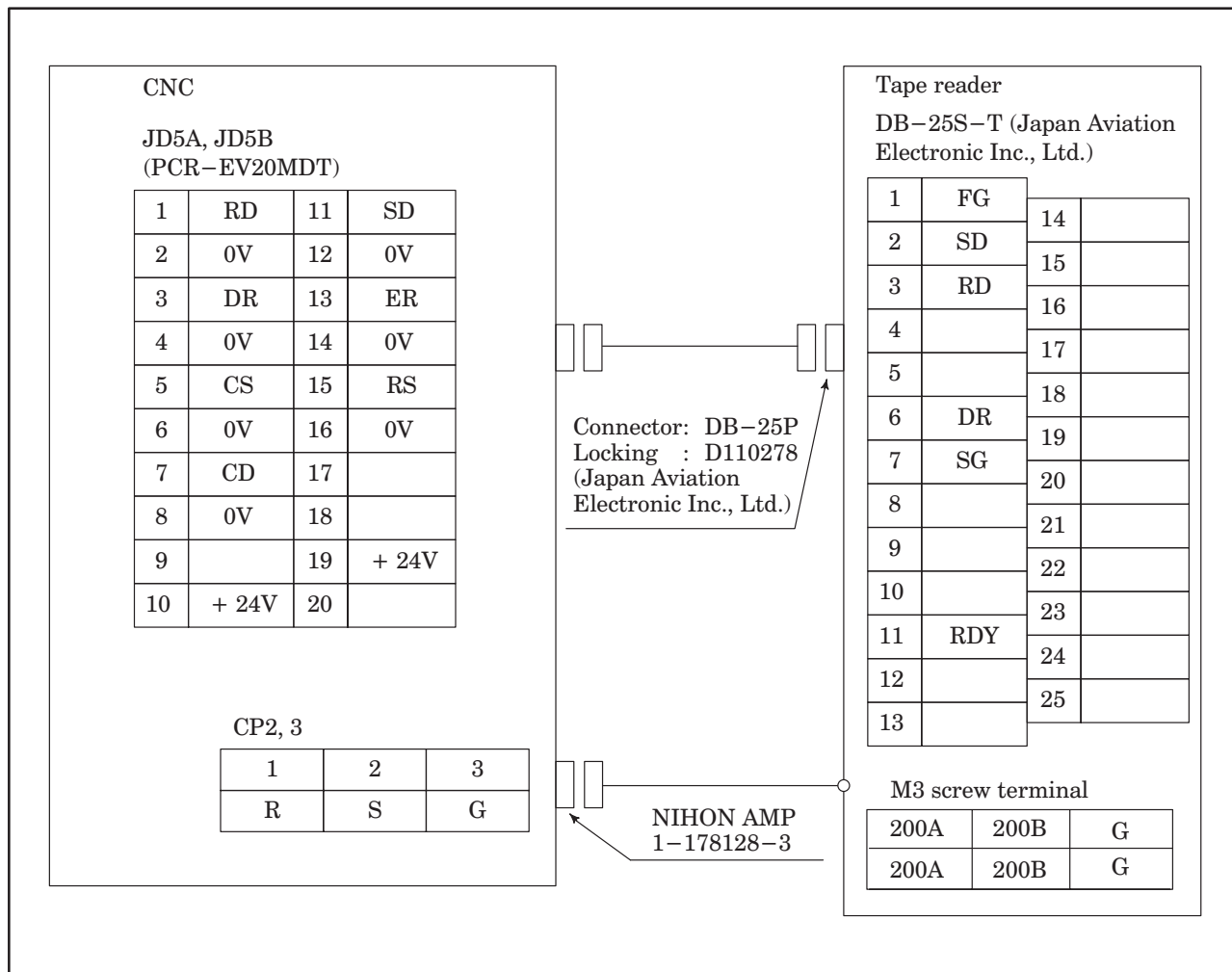

4.6.6 Connection of tape reader with reels

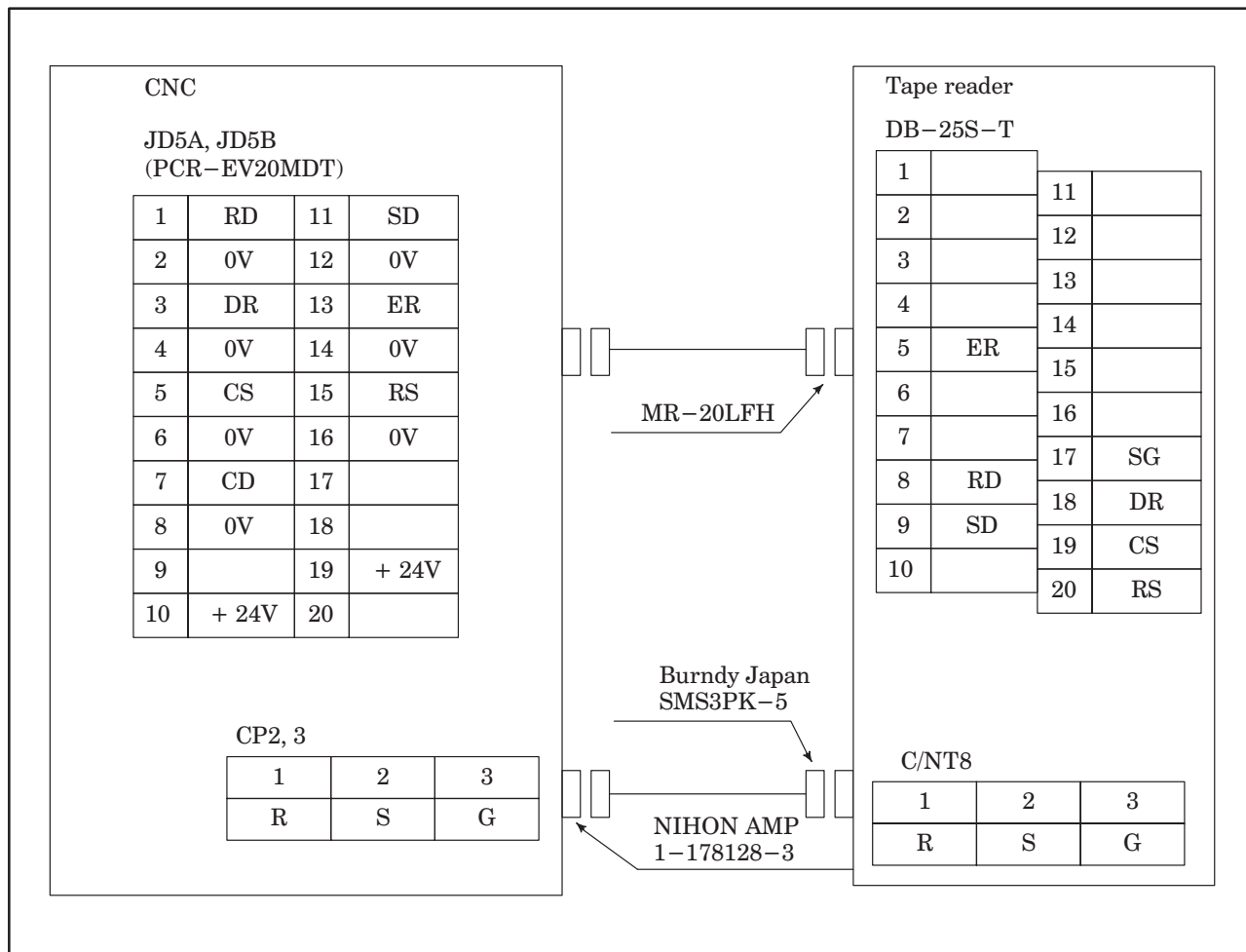



## 5. STARTUP AND ADJUSTMENTS

### 5.1 Startup and Adjustment Procedures

After installation, adjust the CNC according to the following procedures. See items specified in the remarks column for details.

Table 5.1 Startup and Adjustment Procedure

No.	Contents	Remarks
1	Check the external views of control unit and the servo unit.	See Item 5.1 (1)
2	Check the connection of screw terminals.	See Item 5.1 (2)
3	Check external cable connections.	See Item 5.1 (3)
4	When the power source for NC is OFF, connect the power input cable.	See Item 5.1 (4)
5	Check the connections of connectors and PCBs.	See Item 5.1 (5)
6	Confirm the settings of the following: ·Transformer Taps ·Servo amplifier PCB ·Control PCB	See Item 5.1 (6)
7	Check input power source voltage, frequency and phase rotation.	See Item 5.1 (7)
8	Check that output voltages are not shorted to ground.	See Item 5.1 (8)
9	Turn power on and check for proper output voltages.	See Item 5.1 (9)
10	Check interface between NC and machine side.	See Item 5.1 (10)
11	Setting and confirmation should be made for each parameter and setting data.	See Item 5.1 (11)
12	Turn power off.	See Item 5.1 (12)
13	Connect motor power cable.	See Item 5.1 (13)
14	Turn power on.	See Item 5.1 (14)
15	Check movement of each axis by using manual feed operation.	See Item 5.1 (15)
16	Check the servo system.	See Item 5.1 (16)
17	Check whether all functions of NC operate normally.	See Item 5.1 (17)

(1) Check external or internal view of control unit and servo unit

Items
Check for dirt and damage on the exterior of CRT/MDI unit, internal position display unit and internal manual operation board etc..
Check for loose, fixtures, PCBs, and servo amplifiers, etc..
Check for damage to cables. (Sheath strippings etc.)

(2) Check that the connection of screw terminals is correct

Items
Terminal block of input transformer for control. (Primary and secondary side)
Terminal block for 1st servo power transformer. (Primary side, secondary side 100A, B TOH 1,2)
Terminal block for 2nd servo power transformer. (Primary side, secondary side TOH 1,2)
If the terminal block has provisions for a cover, confirm the cover is provided and properly attached.

## (3) External cables connection

Items
After stripping external cover of the cable, confirm that the cable is connected to the ground plate by a metal clamp.
Confirm that the proper sized earth ground cable is connected between the NC and the machine magnetics cabinet.
Check the protection earth is connected at one point to earth ground from the machine magnetics cabinet.
Check that all signal cables are made into same ground plate.
Check that cable specifications are as designated by the connection manual. (For motor signal)
Check that cable specifications are as designated by the connection manual. (For motor drive)
Check that cable specifications are as designated by the connection manual. (For servo amplifier interface)
Check that cable specifications are as designated by the connection manual. (For position coder)
Check that cable specifications are as designated by the connection manual. (For spindle analog output)
Check that cable specifications are as designated by the connection manual. (For manual pulse generator)
Check that cable specifications are as designated by the connection manual. (For the CRT/MDI)
Check that cable specifications are as designated by the connection manual. (For reader/puncher interface)

## (4) Connect the power input cable while the CNC power off

Items
The motor power cables should remain disconnected.

## (5) Check the mounting state of connectors and PCBs

Items
Are nail type fixtures fitted with brown connector for power source?
Are all PCBs and PCBs cables fully inserted?

## (6) Setting confirmation

## (a) Tap set of transformer (see 4.2)

Items
Tap setting of servo power transformer (see 4.2.2).
Tap setting of input transformer for control (see 4.2.1).

## (b) Setting on AC servo amplifier PCB.

## (c) Setting on AC spindle servo unit PCB.

(7) Check input power source voltage, and frequency

Items
When power source is used for control unit and servo unit, confirm the input is applied as follows: 200/220 VAC + 10%, -15% 50/60 Hz $\pm$ 1 Hz, 3 $\phi$ (However, a combination with 220 V and 50 Hz is not allowed.)
Power source input for control unit only is applied as follows: 200/220 VAC + 10%, -15% 50/60 Hz $\pm$ 3%, 1 $\phi$ (However, a combination with 220 V and 50 Hz is not allowed.)
Power source input for servo unit only is applied as follows: 200/220 VAC + 10%, -15% 50/60 Hz $\pm$ 1 Hz, 3 $\phi$ (However, a combination with 220 V and 50 Hz is not allowed.)
The power source for the export transformer matches one of the following voltages: 200/220/230/240/380/415/440/450/480/550 VAC +10%, -15%
Check that the input power capacity is sufficient to meet the consumptive power requirements of the control unit and the servo unit.

(8) Confirm that output power lines are not short-circuited with the ground line

Items
When the DC power line outputs (+24V and +24E) from the power supply unit are used, confirm that they are not short-circuited to the ground in the cable. Check for short-circuits at the cable connector.

(9) Turn power on and check output voltage (Refer to section 4.1)

Items		
Confirm each output voltage at test points on servo amp. PCB.	(+24V)	+22 to 27V
	(+15V)	+14.55 to 15.45V
	(-15V)	-14.55 to -15.45V

(10) Check interface signal between CNC and machine side

Items
See Section 3.3.1, "Diagnostic functions related to interfaces to the machine."

(11) Set and confirm each parameter and setting data

Items
See Chapter 6, "Displaying and Specifying Parameters."

(12) Turn off the power supply

(13) Connect the motor power line

(14) Turn on the power supply

Items
Perform the corrective action according to the alarm list, if an alarm occurred.
Repeat the power on/off operation and emergency stop several times, and make sure that the motor does not rotate.

(15) Examine the movement of each axis by manual feed

Items
Try moving each axis by 10 $\mu$ m increments using the MPG or incremental feed, and check if the machine moves the commanded distance.
Intentionally trip the machine mounted limit switches while manually jog feeding each axis with a low override setting. Make sure that the machine stops moving when an overtravel alarm is detected.
Move each axis while changing the override by manual JOG feed and manual rapid traverse, and confirm that alarms like excessive error, etc. do not appear even at the maximum feedrate.

(16) Check the servo system

Items	
Operate each axis using the F4 digit feed in MDI mode, and check the positional deviation amount (DGN No. 300). Determine the servo loop gain from the feedrate and positional deviation amount by the following equation.	
$G = \frac{16.7F}{E}$	F : Feedrate (mm/min) (0.1 in/min) , (deg/min) E : Positional deviation amount (0.001 mm) , (0.001 in) , (0.01 deg) G : Servo loop gain (sec <sup>-1</sup> ) (standard: 30 sec <sup>-1</sup> )
Check the servo loop gain given by the above calculation is within $\pm 10\%$ of the desired value.	

(17) Confirm that all CNC functions operate normally

Items	
Perform a reference point return procedure.	
Perform the procedure or setting the grid shift amount. This setting will only become effective after power is turned off and on again.	
Confirmation is required.	
Execute the supplied machine test tapes while carefully observing the machine for any errors.	

## 5.2 Adjusting a Flat Display

Flat displays, such as color liquid crystal displays and plasma displays, require fine adjustment of the video signal. This adjustment is necessary to compensate for variations in the signal resulting from differences in the CNC unit and the cables being used.

- Location of adjustment switches (rear of display)

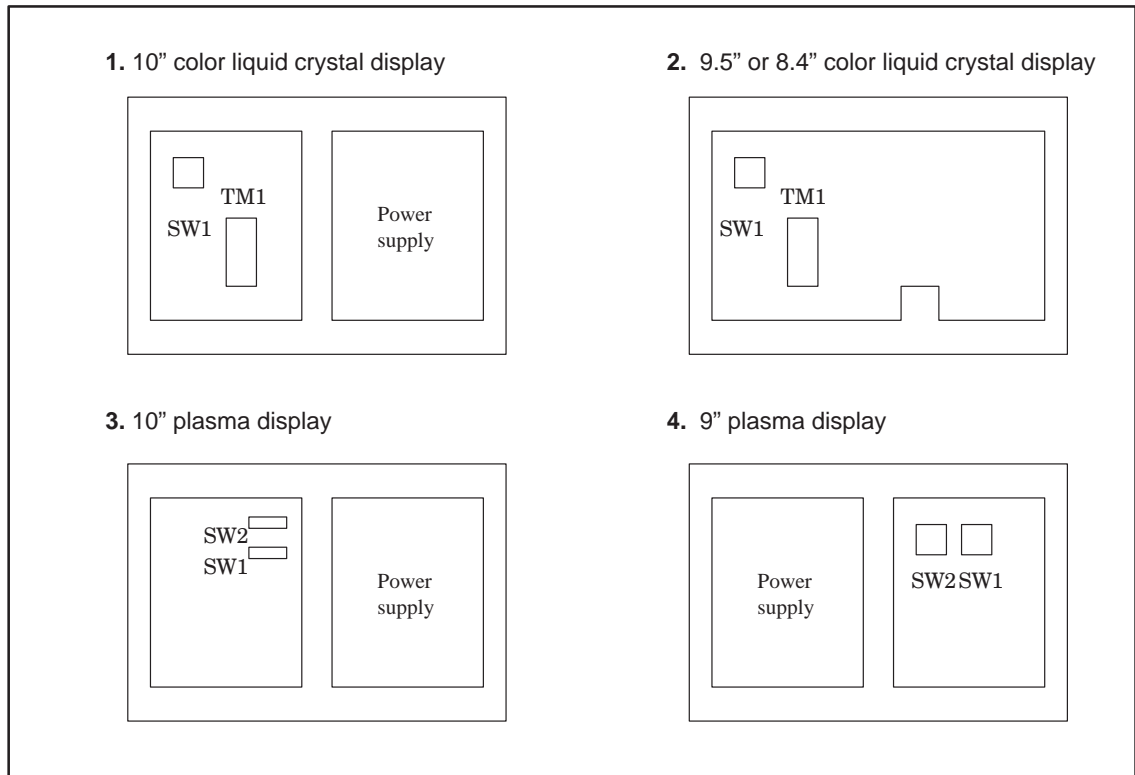

- Suppressing flicker

To suppress flicker, set the following switches:

- |  |     |
|--|-----|
| 1. 10" color liquid crystal display :          | TM1 |
| 2. 9.5" or 8.4" color liquid crystal display : | TM1 |
| 3. 10" plasma display :                        | SW2 |
| 4. 9" plasma display :                         | SW1 |

Change the setting of the switch and note the range where no flicker occurs. When several settings eliminate flicker completely, set the switch to the middle position of those settings.

**Example** When no flicker occurs with settings 2 to 6, set the switch to 4.

- Adjusting the horizontal position

To adjust the horizontal position of the screen, use the following switches:

- |  |     |
|--|-----|
| 1. 10" color liquid crystal display :          | SW1 |
| 2. 9.5" or 8.4" color liquid crystal display : | SW1 |
| 3. 10" plasma display :                        | SW1 |
| 4. 9" plasma display :                         | SW2 |

You can move the screen horizontally in units of dots. Adjust the screen so that the entire screen can be seen. There is only one such position. The screen is factory-set to this position and usually need not be adjusted.

- Others

Do not change any settings other than the above, including the volume control.

## 6. DISPLAYING AND SPECIFYING PARAMETERS

### 6.1 Displaying Parameters

#### 6.1.1 Displaying parameters other than those related to pitch error compensation

(1) Press the **SERVICE** soft key, then press the **PARAM** soft key to display the parameter screen.

(2) Enter the number of the parameter to be displayed and press the **INP-NO.** soft key.

The screen can also be changed using the cursor or page key instead of entering the number.

#### 6.1.2 Displaying parameters related to pitch error compensation

(1) Press the **SERVICE** soft key, then press the **PITCH** soft key to display the parameter screen.

(2) Enter the number of the parameter to be displayed and press the **INP-NO.** soft key.

The screen can also be changed using the cursor or page key instead of entering the number.

## 6.2 Specifying Parameters

### 6.2.1 Formats of parameter tapes

(1) Formats of parameter tapes other than those for pitch error compensation

The parameters can be classified according to the data types as follows:

Data type	Valid range	Remarks
Bit	0 or 1	
Bit axis	0 or 1	
Byte	0 to $\pm 127$	
Byte axis	0 to $\pm 127$	
Word	0 to $\pm 32767$	
Word axis	0 to $\pm 32767$	
2 word	0 to $\pm 99999999$	
2-word axis	0 to $\pm 99999999$	

**NOTE 1** The axis type of data can be specified separately for each axis.

**NOTE 2** The valid ranges are listed for general reference. The valid range depends on the parameter. For details, see description of each parameter.

(a) Format of bit-type parameter tapes

Nnnnn Ppppppppp ;

Nnnnn : Specify a parameter No. with a 4-digit number following N. (Positive integer)

Ppppppppp : Specify parameter values (0 or 1) with an 8-digit number following P.

Eight bit-type parameters are provided for each parameter No. Specify 0 or 1 for the least significant digit as the bit 0 parameter value and for the most significant digit as the bit 7 parameter value. (Positive integer)

:: End of block (ISO code: LF; EIA code: CR)

**NOTE 1** The addresses N and P must be specified in the order shown above.

**NOTE 2** The leading zeros can be omitted.

**Example**

N0000 P00010001 ; or N0 P10001 ;

(b) Format of bit-axis-type parameter tapes

Nnnnn Aaa Ppppppppp ;

Nnnnn : Specify a parameter No. with a 4-digit number following N. (Positive integer)

Aaa : Specify the axis number (1 to 15). (Positive integer)

Ppppppppp : Specify parameter values (0 or 1) with an 8-digit number following P.

Eight bit-type parameters are provided for each parameter No. Specify 0 or 1 for the least significant digit as the bit 0 parameter value and for the most significant digit as the bit 7 parameter value. (Positive integer)

:: End of block (ISO code: LF; EIA code: CR)

**NOTE 1** The addresses N, A, and P must be specified in the order shown above.

**NOTE 2** The leading zeros can be omitted.

**Example**

N0012 A1 P00000011 ; or N12 A1 P11 ;

N0012 A2 P00000010 ; or N12 A1 P10 ;

N0012 A3 P00000010 ; or N12 A1 P10 ;

Parameters for two or more axes can be specified in one block as follows:

N12 A1 P11 A2 P10 A3 P10 ;

## (c) Format of byte-type parameter tapes

Nnnnn Pp... ;

Nnnnn : Specify a parameter No. with a 4-digit number following N. (Positive integer)

Pp... : Specify the parameter value with a number following P. (Integer)

The valid range depends on the parameter.

:: End of block (ISO code: LF; EIA code: CR)

**NOTE 1** The addresses N and P must be specified in the order shown above.**NOTE 2** The leading zeros can be omitted.**Example**

N2010 P100 ;

## (d) Format of byte-axis-type parameter tapes

Nnnnn Aaa Pp... ;

Nnnnn : Specify a parameter No. with a 4-digit number following N. (Positive integer)

Aaa : Specify the axis number (1 to 15). (Positive integer)

Pp... : Specify the parameter value with a number following P. (Integer)

The valid range depends on the parameter.

:: End of block (ISO code: LF; EIA code: CR)

**NOTE 1** The addresses N, A, and P must be specified in the order shown above.**NOTE 2** The leading zeros can be omitted.**Example**

N1020 A1 P88 ;

N1020 A2 P89 ;

N1020 A3 P90 ;

Parameters for two or more axes can be specified in one block as follows:

N1020 A1 P88 A2 P89 A3 P90 ;

## (e) Format of word-type parameter tapes

Same as that of byte-type parameter tapes

## (f) Format of word-axis-type parameter tapes

Same as that of byte-axis-type parameter tapes

## (g) Format of 2-word-type parameter tapes

Same as that of byte-type parameter tapes

## (h) Format of 2-word-axis-type parameter tapes

Same as that of byte-axis-type parameter tapes

Example of a parameter tape other than that for pitch error compensation

% ;

N0 P1 ;

N3 P0 ;

N10 P10 ;

N11 P0 ;

:

:

:

%

## (2) Formats of parameter tapes for pitch error compensation

Nnnnnn Ppp ;

Nnnnnn : Specify a parameter No. with a 5-digit number (10000 + pitch error compensation number) following N. (Positive integer)

Ppp : Specify the value of the pitch error compensation parameter with a number following P. (Integer)  
Specify a number between -7 and 7.

:: End of block (ISO code: LF; EIA code: CR)



**NOTE** The addresses N and P must be specified in the order shown above.

Example of a parameter tape for pitch error compensation (ISO code)

```
% ;
N10000 P1 ;
N10001 P4 ;
N10002 P-7;
N10003 P-3;
N10004 P2 ;
:
:
:
%
```

### 6.2.2 Specifying parameters through the reader/punch interface

- (1) Put the CNC in the MDI mode or place it in the emergency stop state.
- (2) Press the **SETTING** soft key to display the setting screen.
- (3) Enter 8000.
- (4) Press the **INP-NO.** soft key to display parameter No. 8000.
- (5) Enter 1 and press the **INPUT** soft key. Parameter PWE is set to 1 and parameters can be specified. The CNC enters the alarm status.
- (6) Press the function menu key to put the soft keys in the function selection mode.
- (7) Press the **SERVICE** soft key, then press the **PARAM** soft key to display the parameter screen.
- (8) Turn on the power to a unit connected to the reader/punch interface and insert a medium such as a tape or disk which contains parameters in the unit.
- (9) Press the **READ** soft key, then press the **ALL** soft key to read parameters through the reader/punch interface.
- (10) Turn off the CNC power.

### 6.2.3 Specifying parameters through the MDI

- (1) Put the CNC in the MDI mode or place it in the emergency stop state.
- (2) Press the **SETTING** soft key to display the setting screen.
- (3) Enter 8000.
- (4) Press the **INP-NO.** soft key to display parameter No. 8000.
- (5) Enter 1 and press the **INPUT** soft key. Parameter PWE is set to 1 and parameters can be specified. The CNC enters the alarm status.
- (6) Press the function menu key to put the soft keys in the function selection mode.
- (7) Press the **SERVICE** soft key, then press the **PARAM** soft key (the **PITCH** soft key for pitch error compensation parameters) to display the parameter screen.
- (8) Enter the Nos. of the parameters to be specified and press the **INP-NO.** soft key to display the parameters on the parameter screen.
- (9) Enter the value to be specified and press the **INPUT** soft key to set the value.

To specify values continuously for the parameter with the specified No. and the subsequent parameters, separate the values with a semicolon (;).

#### Example

Enter 10 ; 20 ; 30 ; 40 and press the **INPUT** soft key. 10, 20, 30, and 40 are specified for the parameter at the cursor and the subsequent three parameters, respectively.

- (10) Repeats steps (7), (8), and (9).
- (11) After specifying the parameters, set the PWE bit of parameter No. 8000 to 0 to inhibit setting the parameters.
- (12) Reset the CNC to release the alarm indicated by the message PARAMETER SETTING ENABLED. If the alarm message PARAMETER REQUIRING NC POWER-OFF WAS SPECIFIED is displayed, turn off the CNC power.

## 6.3 Outputting Parameters

### 6.3.1 Outputting all parameters

- (1) Connect an output unit to the reader/punch interface.
- (2) Put the CNC in the EDIT mode.
- (3) Press the **SERVICE** soft key, then press the **PARAM** soft key to display the parameter screen.
- (4) Press the **PUNCH** soft key, then press the **ALL** soft key to output all parameters.

### 6.3.2 Outputting the parameters excluding those related to pitch error compensation

- (1) Connect an output unit to the reader/punch interface.
- (2) Put the CNC in the EDIT mode.
- (3) Press the **SERVICE** soft key, then press the **PARAM** soft key to display the parameter screen.
- (4) Press the **PUNCH** soft key, then press the **PARAM** soft key to output all parameters excluding those related to pitch error compensation.

### 6.3.3 Outputting parameters for pitch error compensation

- (1) Connect an output unit to the reader/punch interface.
- (2) Put the CNC in the EDIT mode.
- (3) Press the **SERVICE** soft key, then press the **PITCH** soft key to display the parameter screen.
- (4) Press the **PUNCH** soft key, then press the **PITCH** soft key to output pitch error compensation parameters.

**NOTE** If an attempt is made to output parameters to a FANUC Cassette (a floppy disk) which contains a parameter file, the alarm DR OFF occurs and no parameters are written. In this case, use an empty disk or delete the existing parameter file, then output the parameters.

## 6.4 Parameters

Parameters are specified by type of function as follows. For details, see operator's manual (Appendix)

Parameter list

### 1) Parameters related to setting

Parameter No.	Contents
0000	TV check is performed or not. TV check is performed or not during control out. ISO code is with parity bit or not. Method of punching EOB by ISO code. Punch code is ISO or EIA.
0010	Input unit is by metric or inch. Single block stop in custom macro is performed or not.
0011	08000 to 08999 programs can be edited or not. 08000 to 08999 programs are displayed on executing.
0012	Mirror image ON/OFF. Each axis scaling Validity/Invalidity.
0020, 0021	Input device No. for foreground.
0022, 0023	Input device No. for background.

### 2) Parameters related to timer

Parameter No.	Contents
0100	Timer 1 (Accumulated power on hour).
0101	Timer 2 (Accumulated automatic operation hour).
0102	Timer 3 (Accumulated automatic operation hour).

### 3) Parameters related to axis control

Parameter No.	Contents
1000	In-position and interlock condition.
1002	Linear axis detection unit.
1004	Each axis setting unit. Input unit is multiplied by 10 or not.
1005	Setting related to reference point return. External deceleration signal, machine lock, and axis detach signal are valid or invalid.
1006	Setting inch/metric conversion is required or not. Setting machine coordinate system for stroke check and automatic reference point return. Setting machine coordinate system for stored pitch error compensation. Axis movement amount is specified by diameter or radius. Specifying manual reference point return direction.
1020	Program axis name of each axis.
1021	Axis number in parallel axis.
1022	Specifying each axis in basic coordinate system.
1023	Servo axis number of each axis.
1030	2nd auxiliary function command address.
1031	Standard axis.

## 4) Parameters related to coordinate system

Parameter No.	Contents
1220	Each axis external work zero point offset value.
1221	Work zero point offset value of work coordinate system 1.
1222	Work zero point offset value of work coordinate system 2.
1223	Work zero point offset value of work coordinate system 3.
1224	Work zero point offset value of work coordinate system 4.
1225	Work zero point offset value of work coordinate system 5.
1226	Work zero point offset value of work coordinate system 6.
1240	Coordinate value of the 1st reference point in the machine coordinate system.
1241	Coordinate value of the 2nd reference point in the machine coordinate system.
1242	Coordinate value of the 3rd reference point in the machine coordinate system.
1243	Coordinate value of the 4th reference point in the machine coordinate system.
1260	Movement value of rotary axis per rotation.

## 5) Parameters related to feed rate

Parameter No.	Contents
1400	Dry run is valid or invalid for rapid traverse command. Dry run is valid or invalid for thread cutting command. Manual rapid traverse is valid or invalid from reference point return after power on. Skip function feed rate. Positioning is by non-linear interpolation type or linear interpolation type. 2nd feed rate override is valid or invalid.
1401	External deceleration invalid for all feeds or only for rapid traverse.
1410	Dry run rate.
1412	Percentage to rapid traverse override F1.
1413	Manual handle feed allowable flow.
1414	Magnification n of manual handle feed.
1420	Rapid traverse rate of each axis.
1421	Fo-rate for each axis rapid traverse override.
1422	Maximum cutting feed rate of each axis.
1423	Jog feed rate of each axis.
1424	Manual reference point return FM rate of each axis.
1425	Manual reference point return FL rate of each axis.
1426	External deceleration rate for cutting feed.
1427	External deceleration rate at rapid traverse of each axis.
1428	Feed rate of skip function.

## 6) Parameters related acceleration/deceleration control

Parameter No.	Contents
1600	Rapid traverse acceleration/deceleration is by linear or exponential.
1620	Linear type rapid traverse acceleration/deceleration time constant of each axis.
1621	Linear type rapid traverse acceleration/deceleration FL rate of each axis.
1622	Cutting feed acceleration/deceleration constant time of each axis.
1623	Cutting feed acceleration/deceleration FL rate of each axis.
1624	Jog feed acceleration/deceleration constant time of each axis.
1625	Jog feed acceleration/deceleration FL rate of each axis.

Parameter No.	Contents
1626	Chamfering time constant at thread cutting cycle of each axis.
1627	FL rate at thread cutting cycle of each axis.
1628	Exponential type rapid traverse acceleration/deceleration time constant of each axis.
1629	Exponential type rapid traverse acceleration/deceleration FL rate of each axis.
1630	Parameter 1 to establish linear acceleration/deceleration prior to interpolation.
1631	Parameter 2 to establish linear acceleration/deceleration prior to interpolation.

## 7) Parameters related to servo

Parameter No.	Contents
1800	Automatic drift compensation is performed or not. Servo alarm occurs or not when velocity control ready signal (VRDY) turns on before position control ready signal turns on. Follow-up is performed or not during servo-off.
1802	Automatic setting of phase shift value has completed or not. Servo off signal is valid or invalid.
1810	Feed back pulse frequency is checked or not. Setting of compensational rate of backlash and pitch error compensation. Position control LSI is checked or not at turning on power. Feed back pulses of pulse coder is monitored or not.
1815	Position detective method is by digital feed back or analog feed back. Whether the position detector is an optical scale. Tolerance when the feed back pulses of the pulse coder are monitored.
1816	Setting of reference counter capacity. Setting of detective multiplier.
1820	Command multiplier (CMR) of each axis.
1825	Servo loop gain of each axis.
1826	Loop gain multiplier of each axis.
1827	In-position width of each axis.
1828	Position deviation limit value at servo off of each axis.
1829	Position deviation limit value at stoppage of each axis.
1830	Position deviation limit value at servo off at each axis.
1831	Lowest clamp value of velocity command value of each axis.
1832	Feed stop position deviation of each axis.
1833	Position detector phase shift value of each axis.
1834	Drift compensation amount of each axis.
1835	Number of pulse per pulse coder one rotation.
1850	Grid shift amount of each axis.
1851	Backlash compensation of each axis.
1890	Feed back pulse check move distance of each axis.

## 8) Parameters related to DI/DO

Parameter No.	Contents
2000	Resetting signal (RST) is always output or only when reset button on MDI panel is pressed. Rewinding signal (RWD) is output only when tape reader is rewinded or when either tape reader or program in memory is rewinded. Cycle start lamp signal (STL) is output or not during operation by manual numeric command. Cycle start lamp signal is output or not when programs are registered by cycle start signal in tape editing mode. Cycle operating signal (OP) is turned on or not at searching for sequence number. MDI mode can be started or not by pressing start button on the panel. Programs are registered by cycle start signal in tape editing mode or not.
2001	Reset or alarm is effective at emergency stop. If all of the mode selection signal turn off, no mode is assumed, or the previously selected mode is assumed. Incremented feed amount is specified by magnification specification signals MP1, MP2, and MP3. Rapid traverse override signal ROV1 and ROV2 has a standard interface or logical 0/1 reverse interface. Selection BMI or FS3/FS6 as machine interface. Selection FS3 or FS6 interface. External operation command signal EF is output or not.
2010	Delay time of strobe signal MF, SF, TF, BF.
2011	Acceptance width of M, S, T and B function completion signal (FIN).
2014	Mode un selected status ignore time.
2015	Invalid mode selection status ignore time.
2016	Manual feed rate override clamp value.
2017	Software operator's panel (+) direction command button.
2021	Software operator's panel (-) direction command button.

## 9) Parameters related to MDI/EDIT/CRT

Parameter No.	Contents
2200	All of the programs are loaded at once by external I/O device next to programs previously loaded or after deleting previous programs. When programs with the same program number as the one already loaded, program can not be loaded by alarm or loaded after deleting previously loaded programs. M02, M30 and M99 are assumed as program end or not in program loading. M99 is assumed as program end in program loading. Program No. 09000 – 09999 are deleted or not by all program deleting operation or command.
2201	Program editing of program No. 09000 to 09999 is prohibited or not. Program No. 09000 – 09999 are displayed or not during execution. Single block is stopped or not at the macro statement of programs 09000 – 09999.
2202	Display on external position display and position display on CRT are by standard unit or by 10 magnification of standard unit. External position display, CRT relative position display and absolute position display include tool length compensation value or not. External position display, CRT relative position display, CRT relative position display and absolute position display include tool length compensation value or not. External position display, CRT relative position display and absolute position display include tool radius compensation/tool nose R compensation value or not. External position display, CRT relative position display and absolute position display are with considering the delay at acceleration/deceleration control or not. External position display, CRT relative position display and absolute position display are with considering the delay in servo or not. Machine position display or CRT is with considering the delay at acceleration/deceleration control or not. Machine position display on CRT is with considering the delay at servo or not.

Parameter No.	Contents
2203	Machine position display on CRT is by detective unit or inch/metric unit.
2311 to 2388	Names of general-purpose switches on the software operator panel.

## 10) Parameters related to programming

Parameter No.	Contents
2400	Decimal point is input by conventional or calculator method. Feed per minute F code in metric without decimal point is processed by 1 mm/min or 0.1 mm/min unit. Commands of inch input and metric input are G20/21 or G70/71. Condition setting of M30 at memory operation. Always dwell per minute or dwell per minute in feed per minute mode and dwell per revolution in feed per revolution in feed per revolution mode. G code system selection.
2401	Mode at power turn on and in clear status.
2402	Travel command path for absolute are same as for incremental or not after manual intervention by manual absolute on. Whether the workpiece coordinate system is preset at manual reference position return. E code specification
2410	Arc radius error limit value.
2411 to 2418	M codes 1 – 8 which do not perform buffering.
2900	Distance between double turrets.

## 11) Parameters related to Reader/puncher interface

Parameter No.	Contents
5001 to 5003	I/O device No. connected to Reader /puncher interface.
5011	I/O device No. connected to ASR33/44 interface.
5110, 5120, 5130, 5140, 5150, 5160	Reader/puncher device specification number corresponding to device No. 1 – 6.
5110, 5121, 5131, 5141, 5151, 5161	Stop bit number of Reader/puncher device corresponding to device No. 1 – 6.
5112, 5122, 5132, 5142, 5152, 5162	Band rate corresponding to device No. 1 – 6.

## 12) Parameters related to stroke limit

Parameter No.	Contents
5200	Stored stroke limit inhibited area is in interior or exterior.
5210	Stored stroke limit is checked or not.
5220	(+) direction coordinate value of stored stroke limit 1 of each axis.
5221	(-) direction coordinate value of stored stroke limit 1 of each axis.
5222	(+) direction coordinate value of stored stroke limit 2 of each axis.
5223	(-) direction coordinate value of stored stroke limit 2 of each axis.
5224	(+) direction coordinate value of stored stroke limit 3 of each axis.
5225	(-) direction coordinate value of stored stroke limit 3 of each axis.

## 13) Parameters related pitch error compensation

Parameter No.	Contents
5420	Pitch error compensation number for reference point of each axis.
5421	Pitch error compensation point number nearest the “-” end of each axis.
5422	Pitch error compensation point number nearest the “+” end of each axis.
5423	Pitch error compensation magnification for each axis.
5424	Interval of pitch error compensation for each axis.
5425	Movement amount per rotation in rotating axis type pitch error compensation.

## 14) Parameters related to inclination compensation

Parameter No.	Contents
5461 to 5464	Compensation point number a – d on each axis.
5471 to 5474	Compensation $\alpha$ to $\varepsilon$ at points a to d for each axis.

## 15) Parameters related to straightness compensation

Parameter No.	Contents
5481 5482 5483	Axis number of moving axis.
5491 5492 5493	Axis number of compensation axis related to moving axis.
5501 to 5524	Points a to d at which compensation is applied for axes 1 to 3 along which the tool moves.
5551 to 5574	Compensation at points a to d for axes 1 to 3 along which the tool moves.



## 16) Parameters related to spindle control

Parameter No.	Contents
5600	Voltage polarity of spindle speed analog output. Gear change system during thread cutting or tapping. Spindle orientation or gear shift is performed by spindle orientation signal (SOR). Spindle speed output is by analog or 12 bit binary output.
5601	Spindle override is valid or invalid. Spindle override is valid or invalid during thread cutting or tapping. When spindle speed command beyond maximum spindle speed, speed is clamped to maximum speed or an alarm occurs. Gear select signal output is code output or signal output corresponding to gear selection. SF signal is output or not when gear select signal is output or when S code is commanded. Type of spindle speed analog output/spindle speed binary output. Gear selection on the machine side.
5602	Spindle stop signal (SSTP) input type. One of gear select signal and BCD S code is output or both of them are inputted. Gear select signal input type. Alarm of spindle velocity control unit is checked or not. Tool position offset amount is excluded or not from the preset position of constant surface speed controlled axis. Tool length compensation amount is excluded or not from the preset position of constant surface speed controlled axis. Preset position or end point coordinate value is used in positioning command during constant surface speed control. Speed arrival signal is used or not.
5603	Gear select condition for 3/6 interface. Position coder disconnection is checked or not.
5610	Gear ratio of spindle to position coder.
5611	Sampling number for finding the moving average of spindle speed.
5612	Spindle speed unit generated by BMI.
5613	Offset voltage compensation value of spindle speed analog output.
5614	Gain adjusting data of spindle speed analog output.
5615	Spindle speed during spindle gear shift.
5616	Time upto new spindle speed after spindle gear select signal is output.
5617	Spindle speed during spindle orientation.
5618	Minimum clamp speed of spindle motor.
5619	Maximum clamp speed of spindle motor.
5620	Time for checking the speed arrival signal.
5621 to 5628	Maximum spindle speed corresponding to gears.
5631 to 5637	Spindle speed at each gear switching point during tapping and thread cutting.
5640	Axis number of constant surface speed.
5641 to 5648	Minimum spindle speed at gear during constant surface speed control.

## 17) Parameters related to tool compensation

Parameter No.	Contents
6000	New offset value is valid after the next block where D or H code is specified or valid after the next block. Tool position compensation is specified by D code or H code. Tool position compensation is effective or not for arc command. Axis selection for tool length compensation. Tool length compensation vector can be cleared by reset or not. Offset number of tool position offset is specified by low order two digits or by low order one digit of the T code. Condition to execute tool position offset.
6001	Start up type of tool R compensation or tool nose R compensation. Condition of interference check of tool R compensation or tool nose R compensation. Tool position compensation geometry offset is performed shifting work coordinate system or by moving the tool. Tool wear offset of tool position compensation is performed by shifting work coordinate system or moving the tool. Offset number specifying method of geometry and wear in tool position compensation. Offset state when tool number 0 is specified.
6002	Setting of offset amount unit. Tool position compensation amount is specified by diameter or radius value. Position record signal (PRC) is used or not when tool position offset is inputted directly.
6010	Limit value to ignore small movement amount created by tool R compensation.
6011	Denominator constant by three-dimensional tool offset.

## 18) Parameters related to canned cycle

Parameter No.	Contents
6200	Selection of drilling axis in canned cycle. Dwell command is valid or not by P in canned tapping cycle. Tool return direction and movement amount in canned fine boring cycle and canned back boring cycle after spindle orientation. Movement to drilling point in canned cycle is done by rapid traverse or by linear interpolation. Initial level point is changed or not when origin setting is above by reset or MDI during canned cycle. G80 and G81 are specified by canned cycle or external operation command.
6201	Spindle control in canned cycle is performed or not by M code. M05 is output or not when spindle rotation direction is changed. FFIN signal or FIN signal which corresponds to SSP signal and SRV signal. FMF signal is output or not after returning to R point or initial point when SSP and SRV are output. FMF signal is output or not when SSP and SRV are output.
6202	Cutting cycle is performed or not at the block which has no movement command during signal cutting cycle mode. Finishing workpiece is performed or not at the end of roughing cycle. Override can be applied or not to infeed during roughing cycle.
6210	Return amount of canned cycle G73.
6211	Clearance amount of canned cycle G83.
6212	Chamfering amount of thread cutting cycle.
6213	Chamfering angle of thread cutting cycle.
6214	Overcutting override value of roughing cycle.
6215	Retract amount in roughing cycle.
6216	Clearance amount in rough cutting cycle.
6217	Return amount in peck cycle.
6218	Minimum cutting amount in thread cutting cycle.
6219	Finish allowance in thread cutting cycle.

Parameter No.	Contents
6220	Number or spark-out in thread cutting cycle.
6240	Tool retract direction after G76, G87 orientation.

## 19) Parameters related to scaling and coordinate system rotation

Parameter No.	Contents
6400	Designation of angle of coordinate system rotation.
6410	Magnification of scaling.
6411	Angle of coordinate system rotation.

## 20) Parameters related to automatic corner override

Parameter No.	Contents
6610	Minimum reduction ratio at cycle internal cutting speed.
6611	Effective angle for internal corner automatic override.
6612	Reduction ratio at internal corner automatic override.
6613	Deceleration distance to the end point for internal corner automatic corner override.
6614	Deceleration distance from the start point for internal corner automatic corner override.

## 21) Parameters related to one directional positioning

Parameter No.	Contents
6820	One directional positioning and approach amount.

## 22) Parameters related to custom macro

Parameter No.	Contents
7000	Custom macro is called or not by T, S and B codes. Custom common variables 1 #100 – #199 are cleared or not by reset.
7010	EIA code which represents is set by hole pattern.
7011	EIA code which represents is set by hole pattern.
7012	EIA code which represents # is set by hole pattern.
7013	EIA code which represents * is set by hole pattern.
7014	EIA code which represents = is set by hole pattern.
7033	M code that enables custom macro interrupts.
7034	M code that disables custom macro interrupts.
7050 to 7059	G code for calling the custom macro of program No. 9010 to 9019.
7071 to 7079	M code for calling the custom macro of program No. 9001 to 9009.

## 23) Parameters related to skip function

Parameter No.	Contents
7211 to 7214	Feedrate of skip function.

## 24) Parameters related to automatic tool compensation

Parameter No.	Contents
7311 to 7313	Measurement feedrate with tool measurement 1 – 3.
7321 to 7323	$\gamma$ value of tool measurement 1 – 3.
7331 to 7333	$\varepsilon$ value of tool measurement 1 – 3.

## 25) Parameters related to service

Parameter No.	Contents
8000	Parameters setting which can not be specified by setting input are forbidden or allowed. CRT screen when an error is caused. When parameter PWE is 1, an error is indicated or not.
8010	When power is turned off, parameter at data number 8000 is set to 0 or maintained.

## 6.5 Setting and Displaying PMC Data (using the PCPRM soft key)

Parameters for the timer, counter, keep relay, and data table are set and displayed using the CRT/MDI unit. Press the **PCPRM** soft key on the PMC main menu to display the following menu before setting or displaying PMC data.

TIMER	COUNTR	KEEPRL	DATA	POS
-------	--------	--------	------	-----

For setting data, the CNC must be in the MDI mode or emergency stop mode.

### 6.5.1 Setting and displaying timer data

The following describes how to set and display data for the variable timer. Pressing the **TIMER** soft key displays the timer screen.

TIMER			
No	DATA	No	DATA
001	2000	016	1000
002	10000	:	:
:	:	:	:
:	:	:	:
:	:	:	:
:	:	:	:
015	0	030	0

Fig. 6.5.1 Timer Screen

Timer number \ Period	Minimum period	Maximum period
	1 to 8	50ms
9 to 40	8ms	262.136sec

#### (1) Setting and displaying data using the CRT/MDI panel

- To set data, put the CNC in the MDI mode or emergency stop mode. Then turn on the PWE bit of CNC parameter No. 8000 to allow parameters to be set. For displaying data, these operations are not needed.
- Press the **PCPRM** soft key on the PMC main menu. Then press the **TIMER** soft key to display the timer screen (see Fig. 6.5.1).
- Press the **↓** page key until the screen which contains the desired timer data is displayed. To set data, follow steps **4.** to **6.** below.
- Place the cursor where data is to be set on the screen using the cursor keys.
- Enter timer data using the numeric keys. To complete data setting, press the **INPUT** key. To set additional data, repeat steps **3.** to **5.**
- Turn off the PWE bit of CNC parameter No. 8000 after the data has been set. Press the **RET** key to return to the PMC main menu.

### 6.5.2 Setting and displaying counter data

The following describes how to set and display preset and cumulative values for the counter. Pressing the **COUNTR** soft key displays the counter screen.

COUNTER			
No	ADDRESS	PRESET	CURRENT
01	C00	26520	1120
02	C04	1200	0
03	C08	0	0
:			
:			
:			
:			
:			
:			
15			

**Fig. 6.5.2 Counter Screen**

(1) Setting and displaying data using the CRT/MDI panel

1. Press the **PCPRM** soft key on the PMC main menu. Then press the **COUNTR** soft key to display the counter screen (see Fig. 6.5.2).
2. Press the **↓** page key until the screen which contains the desired counter data is displayed. To set data, follow steps 3. to 6. below.
3. Put the CNC in the MDI mode or emergency stop mode. When the BMI interface is used, set the KEY4 signal to 1. When the interface equivalent to FS3 or FS6 is used, set the KEY signal to 1.
4. Place the cursor where data is to be set on the screen using the cursor keys.
5. Enter counter data using the numeric keys. To complete the data setting, press the **INPUT** key. To set additional data, repeat steps 4. and 5..
6. Press the **RET** key to return to the PMC main menu after the data has been set.

### 6.5.3 Setting and displaying keep relay data and data for controlling the retained memory

The following describes how to set and display keep relay data and data for controlling the retained memory. Pressing the **KEEPRL** soft key displays the keep relay screen.

KEEP RELAY		
No	ARRDESS	DATA
01	K00	10100011
02	K01	00011100
:		
:		
:		
:		
:		
:		
:		
15	K14	11000101

**Fig. 6.5.3 Keep Relay Screen**

(1) Setting and displaying keep relay data

1. To set data, put the CNC in the MDI mode or emergency stop mode. Then turn on the PWE bit of CNC parameter No. 8000 to allow parameters to be set. For displaying data, these operations are not needed.

2. Press the **PCPRM** soft key on the PMC main menu. Then press the **KEEPRL** soft key to display the keep relay screen (see Fig. 6.5.3).
  3. Press the **↓** page key until the screen which contains the desired keep relay data is displayed. To set data, follow steps 4 to 6 below.
  4. Place the cursor where data is to be set on the screen using the cursor keys.
  5. Enter keep relay data (bit pattern) using the numeric keys. Press the **INPUT** key to complete the data setting. To set additional data, repeat steps 4 and 5.
  6. Press the **RET** key to return to the PMC main menu after the data has been set.
- (2) Data for controlling retained memory is set and displayed in the same way as for keep relay data. For setting or displaying data for controlling retained memory, display the screen which contains a line with number 17 in the NO column and address K16 in the ADDRESS column. Only the sixth and seventh bits in the DATA column of this line can be used for data setting.

**6.5.4 Setting and displaying data in the data table**

Press the **DATA** soft key on the PMC parameter menu to display the screen of data for controlling the data table (see Fig. 6.5.4 (a)).

When the data for controlling the data table is valid, data table group 1 is displayed by pressing the page key (see Fig. 6.5.4 (b) and Fig. 6.5.4 (c)). Pressing the page key repeatedly lists the contents of the table in sequence. After all the data in data table group 1 have been displayed, subsequent data table groups (data table group 2, data table group 3, ..., data table group n) are displayed in order.

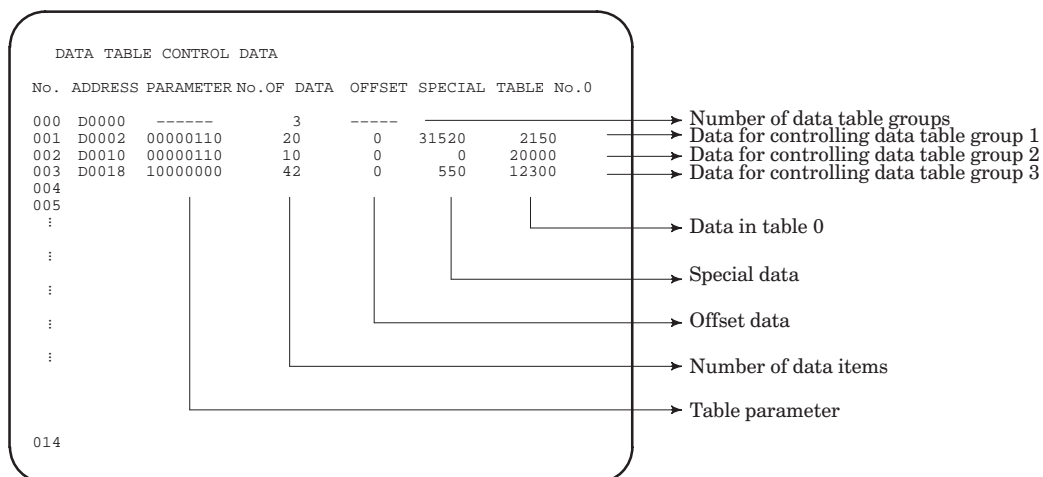

**Fig. 6.5.4 (a) Screen of Data for Controlling the Data Table**

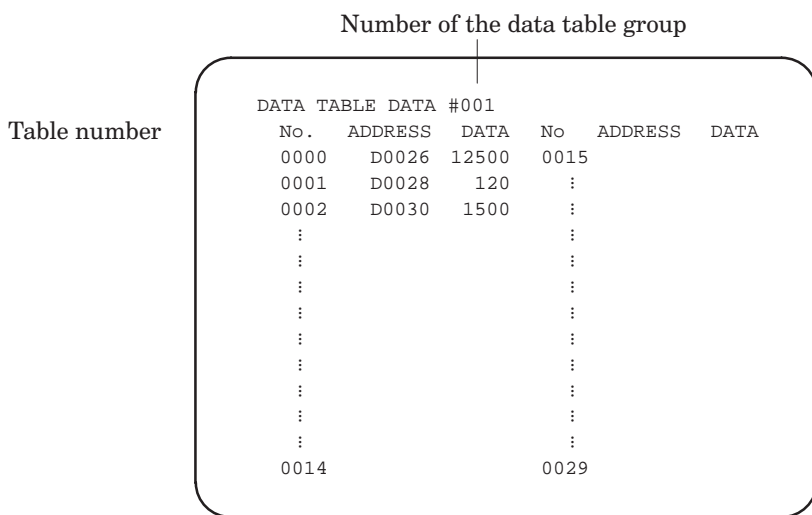

**Fig. 6.5.4 (b) Data Table Screen**

DATA TABLE MONITOR #0.04				
No.	ADDRESS	TOOL No.	MAX.	AVERAGE
01	D0320	11252	250	80
02	D0324	14	190	62
03	D0328	1240	200	73
:				
:				
:				
:				
:				
:				
:				
:				
:				
:				
:				
15				

**Fig. 6.5.4 (c) Data Table Screen of Data to Be Monitored**

(This is the screen which displays teaching data set in MONI (SUB 47) for monitor control.)

(1) Setting and displaying data for controlling the data table

The data for controlling data table groups is displayed as shown in Fig. 6.5.4 (a). A line starting with number 000 in the NO. column must contain the number of data table groups in the NO. OF DATA column.

Lines starting with numbers 001 or more in the NO. column give data for controlling data table groups. (The numbers in the NO. column correspond to the data table group numbers.)

The following data is set and displayed using the CRT/MDI unit.

PARAMETER : Table parameter

NO. OF DATA : Number of data items.

(A line starting with 000 in the NO. column must contain the number of data table groups in the NO. OF DATA column.)

OFFSET : Offset data





SPECIAL : Special data

TABLE NO. 0 : Data in table 0

1. To set data, put the CNC in the MDI mode or emergency stop mode. When the BMI interface is used, set the KEY4 signal to 1. When the interface equivalent to FS3 or FS6 is used, set the KEY signal to 1. For displaying data, these operations are not needed.
2. Press the **PCPRM** soft key on the PMC main menu. Then press the **DATA** soft key.
3. The screen of data for controlling the data table is displayed as shown in Fig. 6.5.4 (a). Pressing the **↓** page key displays the screen which contains control data lines starting with numbers 015 or more in the NO. column. To set data, follow steps 4. to 8. below.
4. Place the cursor where data is to be set on the screen using the cursor keys of the CRT/MDI unit.
5. Enter data for controlling the data table using the numeric keys. Then press the **INPUT** key.
6. At the cursor position, the old data is overwritten with new data.
7. To set additional data, repeat steps 4. to 6..
8. To set data in the data table after the data for controlling the data table has been set, press the **↓** page key until the data table screen is displayed (see item (2) below). To return to the PMC main menu, press the **RET** key.



## (2) Setting and displaying data in the data table

1. To set data, put the CNC in the MDI mode or emergency stop mode. When the BMI interface is used, set the KEY4 signal to 1. When an interface equivalent to FS3 or FS6 is used, set the KEY signal to 1. For displaying data, these operations are not needed.
2. Press the **PCPRM** soft key on the PMC main menu. Then press the **DATA** soft key.  
The screen of data for controlling the data table is displayed as shown in Fig. 6.5.4 (a). Press the  page key until the data table screen is displayed (see Fig. 6.5.4 (b)).  
The table of data table group 1 is displayed first. Pressing the  page key changes to the next data table. Press the  page key until the table of the desired data table group is displayed.
3. When the data table group has more than 30 data items, pressing the  page key displays the 30th and subsequent data items. To set data, follow the steps 4. to 8. below.
4. Place the cursor where data is to be set on the screen using the cursor keys of the CRT/MDI unit.
5. Enter data in the data table using the numeric keys. Then press the **INPUT** key.
6. At the cursor position, the old data is overwritten with new data.
7. To set additional data, repeat steps 4. to 6..
8. Press the **RET** key to return to the PMC main menu after the data has been set in the data table.

**6.5.5 Inputting and outputting PMC data (when the reader/punch interface is used)**

## (1) Setting the input/output channel

When inputting and outputting data, the input/output channel must be correctly set. Once the input/output channel has been set, the setting is maintained even after the CNC is turned off. Therefore, further channel setting is normally not required. If the input/output channel must be again set for some reason, follow the steps below.

1. Press the **CNC/PMC** key to display the PMC screen. When the lower soft key list as shown in the figure below is displayed on the PMC screen, steps 2. to 8. are not needed.

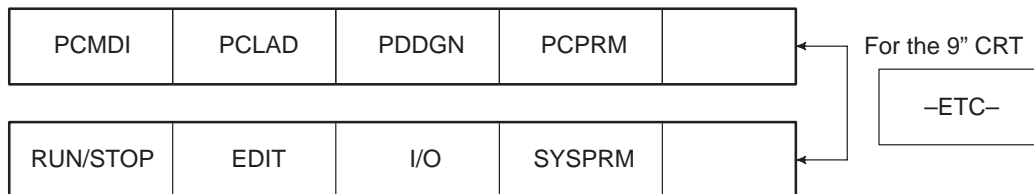

2. Press the **CNC/PMC** key to display the NC screen. Then put the CNC in the MDI mode or emergency stop mode.
3. Press the **SETTING** soft key to display the setting screen.
4. Enter 8000 and press the **INP-NO.** soft key. Parameter No. 8000 is now displayed.
5. If PWE, the lowest bit of parameter No. 8000, is set to 0, change it to 1. Then press the **INPUT** soft key. This sets the PWE bit to 1 and puts the NC in the alarm mode.
6. Press the **CNC/PMC** soft key to display the PMC screen.
7. Press the **PCPRM** soft key. Then press the **KEEPRL** soft key to display the keep relay screen. Press the  page key until the screen which contains the K17 data line is displayed. When this screen is displayed, place the cursor at the K17 data using the cursor keys. Then enter 10000000 and press the **INPUT** soft key. This sets the highest bit of the K17 data to 1. (Keep record of the original K17 data until step 10.)

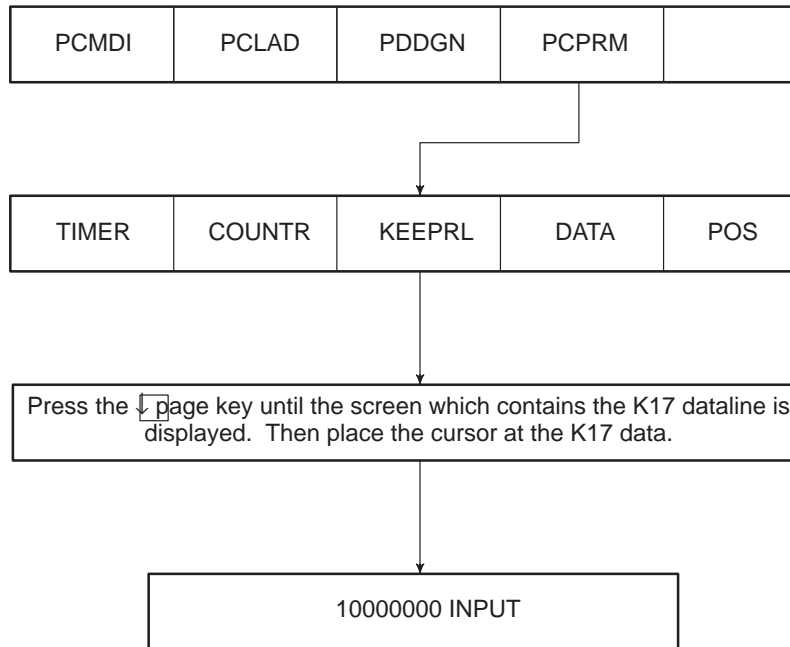

8. Press the return key on the right of the soft keys several times to display the soft key menu as shown in the figure in step 1..
9. Press the soft keys **I/O**, **FDCAS**, and **CHANEL** in that order. Then enter the valid channel number using the keyboard and press the **EXEC** key.

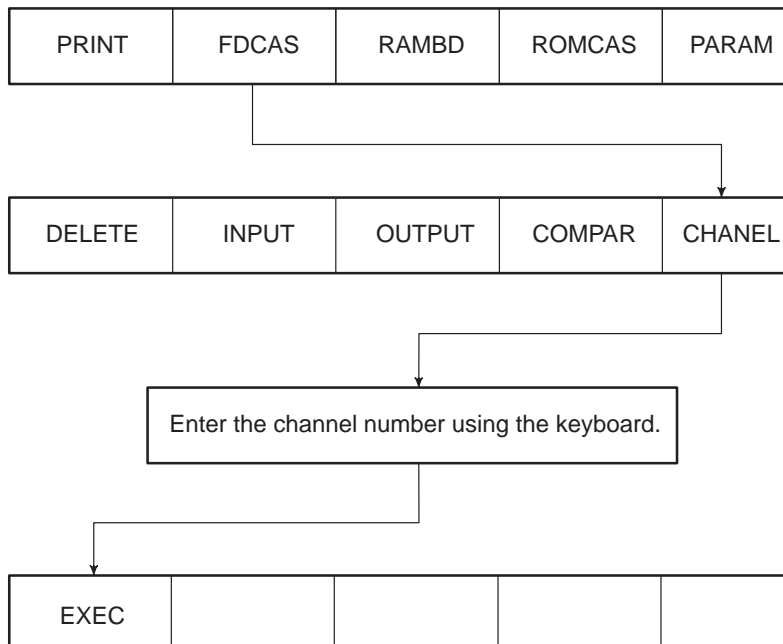

10. If the K17 data for the keep relay was changed in step 7., restore it to the original setting.

**NOTE** To change the baud rate, press the **PCPRM** soft key on the menu as shown in the figure in step 1., and press the **MODE** soft key. Then place the cursor at DATA TRANSFER RATE (AUX) using the **[down arrow]** key. Press the soft key to display the desired baud rate.

#### (2) Inputting PMC data

1. Connect the reader/punch interface of the CNC to the input device which contains PMC data. Then turn the CNC on.
2. Put the CNC in the MDI mode or emergency stop mode.
3. Press the **SETTING** soft key to display the setting screen.
4. Enter 8000 and press the **INP-NO.** soft key. Parameter No. 8000 is displayed.

- If PWE, the lowest bit of parameter No. 8000, is set to 0, change it to 1. Then press the **INPUT** soft key. This sets the PWE bit to 1 and puts the NC in the alarm mode.
- Press the **NC/PC** soft key to display the PMC screen.

PCMDI	PCLAD	PDDGN	PCPRM	
-------	-------	-------	-------	--

- Press the PCPRM soft key to display the PC parameter screen. The soft keys are displayed as shown below.

TIMER	PCLAD	KEEPRL	DATA	POS	← <b>-ETC-</b>
MODE	I/O	CLRPRM			

- Press the I/O soft key. (For the 9" CRT, press the **-ETC-** key.)

	INPUT	OUTPUT		
--	-------	--------	--	--

- Press the INPUT soft key. Then enter the name or number of the file and press the **EXEC** key.

EXEC				
------	--	--	--	--

- The correspondig addresses are displayed to show that the data has been correctly input.

**NOTE** When data is read, if RAMENABLE OFF is displayed, this means that the RAM for the PMC is protected. Press the **MODE** soft key on the menu as shown in the figure in step 7.. Then place the cursor at RAM ENABLE using the **↓** key and press the **ON** softkey.

### (3) Outputting PMC data

- Connect the reader/punch interface of the CNC to the device which outputs PMC data. Then turn the CNC on.
- Press the NC/PC soft key to display the PMC screen.

PCMDI	PCLAD	PDDGN	PCPRM	
-------	-------	-------	-------	--

- Press the **PCPRM** soft key to display the PC parameter screen. The soft keys are displayed as shown below.

TIMER	PCLAD	KEEPRL	DATA	POS	← <b>-ETC-</b>
MODE	I/O	CLRPRM			

- Press the **I/O** soft key. (For the 9" CRT, press the **-ETC-** key.)

	INPUT	OUTPUT		
--	-------	--------	--	--

- Press the soft keys **OUTPUT**, **PARAM**, and **S.FORM** in that order. Enter the file name using the keyboard and press the **ADD** key. Then the device outputs the data.

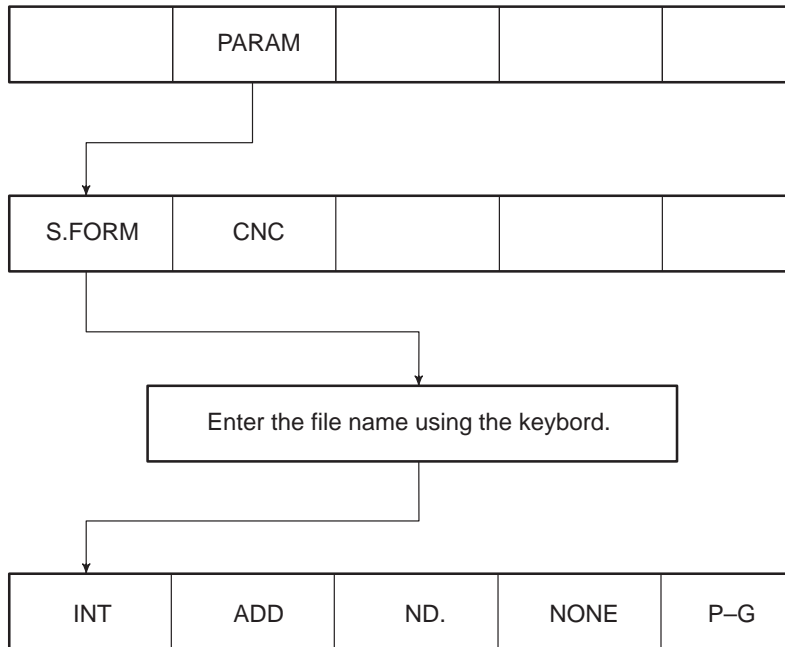

6. The corresponding addresses are displayed to show that the data is normally output.

## 6.6 Input/Output of CNC Data

### 6.6.1 Setting the parameters necessary for input/output

The FS15B allows you to set the parameters necessary for data communication via the RS-232C, RS-422, or remote buffer interface, from a single screen. Once you have set the parameters, the settings are held, even when the power is disconnected.

- Selecting the RS-232C screen

To select the RS-232C screen, press the SETTING function selection key repeatedly until the screen appears, or press the SETTING key, then RS-232C soft key.

RS-232C screen for 9" CRT/MDI

```

SETTING(RS232C)          00001 N00000
TV CHECK   =ON           TV(COMMENT)=ON
I/O CODE   =ISO
EOB CODE   =LF/CR/CR PNCH
F.G. INP DVC = 1      RS232C DVC TYPE =   8
      OUT DVC = 1      CHANL1 STOP BITS=   2
B.G. INP DVC = 2      RS232C DVC TYPE =   8
      OUT DVC = 2      CHANL2 STOP BITS=   2
                        BAUD RATE= 9600
                        RS232C DVC TYPE =   8
                        CHANL2 STOP BITS=   2
                        BAUD RATE= 9600

By "SELECT +/-" Key, please select
OFF/ON.

MDI ***  RESET ***           13:33:08
SELECT+  SELECT-             CHAPTER

```



Switched with page key  or .

```

SETTING(RS232C)          00001 N00000
TV CHECK   =ON           TV(COMMENT)=ON
I/O CODE   =ISO
EOB CODE   =LF /CR/CR PNCH
F.G. INP DVC = 1      RS232C DVC TYPE =   8
      OUT DVC = 1      CHANL3 STOP BITS=   2
B.G. INP DVC = 2      RS422  DVC TYPE =   8
      OUT DVC = 2      STOP BITS=   2
                        BAUD RATE= 9600
                        RS422  DVC TYPE =   8
                        STOP BITS=   2
                        BAUD RATE= 9600

By "SELECT +/-" key, please select
OFF/ON.

MDI ***  RESET ***           13:33:08
SELECT+  SELECT-             CHAPTER

```

\* The second page is displayed only when the reader/punch interface B option is installed.

When the remote buffer interface option is installed, the remote buffer setting screen is displayed on the third page. Refer to the remote buffer supplementary explanation for details of the values to be set.

## – Setting parameters

position the cursor to the parameter to be set, then change its value by pressing the SELECT+ or SELECT– soft key. Each parameter can be set to a value within the range specified for that parameter. (To display the SELECT+ and SELECT– soft keys, press the CHAPTER key.)

\* Parameters can be set regardless of the current mode.

\* You cannot enter a value directly. Use the soft keys to change the value to the desired value.

## (A) TV CHECK

ON : Performs TV check.

OFF : Does not perform TV check.

## (B) TV(COMMENT)

ON : Performs TV check for comments also (during control out).

OFF : Does not perform TV check for comments.

## (C) I/O CODE or IN/OUT CODE

ISO : Uses ISO code for input/output.

EIA : Uses EIA code for input/output.

ASCII : Uses ASCII code for input/output.

## (D) EOB CODE

LF/CR/CR PNCH : The EOB code is LF/CR/CR PNCH.

LF PNCH : The EOB code is LF PNCH.

## (E) F.G. INP DVC

F.G. OUT DVC

Specify the channel used in the foreground. The table below lists the correspondence between the channel numbers and the connectors on the NC unit.

Channel No	Connector No. on NC unit	Interface used
1	JD5A on main CPU board	RS232C
2	JD5B on main CPU board	RS232C
3	JD5J on main CPU board	RS232C
10*	JD5C or JD6A on OPTION1 board	RS232C or RS422
13	JD6D on SUB board	RS422

\* Whether the RS-232C or RS-422 interface is used for the OPTION1 board depends on the setting of bit 0 of parameter No. 5000.

## (F) B.G. INP DVC

B.G. OUT DVC

Specify the channel used in the background. The correspondence between the channel numbers and connector is the same as that for the channel used in the foreground.

## (G) DVC TYPE

Specify the I/O device connected to each channel.

Value of DVC TYPE	I/O device
1	Tape reader with serial interface (control code: DC1 to DC4)
2	Tape reader with serial interface (control code: not used)
3	Personal computer, etc. (control code: DC1 to DC4)
4	Personal computer, etc. (control code: not used)
5	Tape reader with rewind function
6	FANUC PPR, Handy File (local mode)
7	FANUC Cassette (bubble cassette)
8	FANUC Floppy Cassette, Handy File (remote mode)
	FANUC Program File Mate

## (H) STOP BIT

Specify the number of stop bits, 1 or 2.

\* The standard setting is two stop bits for FANUC I/O devices.

(I) BAUD RATE

Specify the data transfer speed to and from the I/O devices. The following values can be selected:

RS232C	RS422
1200	1200
2400	2400
4800	4800
9600	9600
19200	19200

\* The standard setting is 4800 baud for FANUC I/O devices.

- Notes

(1) The parameters used to specify the device type, number of stop bits, and baud rate for RS-232C channels 1 to 3 are specified with parameters No. 5001 to 5003. Those for the RS-422 channel are specified with parameter No. 5013.

If a value other than 1 to 6 is set in parameter No. 5001, 5002, 5003, or 5013, the corresponding device type, number of stop bits, or baud rate is not displayed on the screen. If the cursor is positioned to a blank, the following message for each channel is displayed in the simple help display frame at the bottom of the setting screen:

CHANL 1:

Please set the parameter 5001 to 1 to 6.

CHANL 2:

Please set the parameter 5002 to 1 to 6.

CHANL 3:

Please set the parameter 5003 to 1 to 6.

RS422:

Please set the parameter 5013 to 1 to 6.

14" CRT

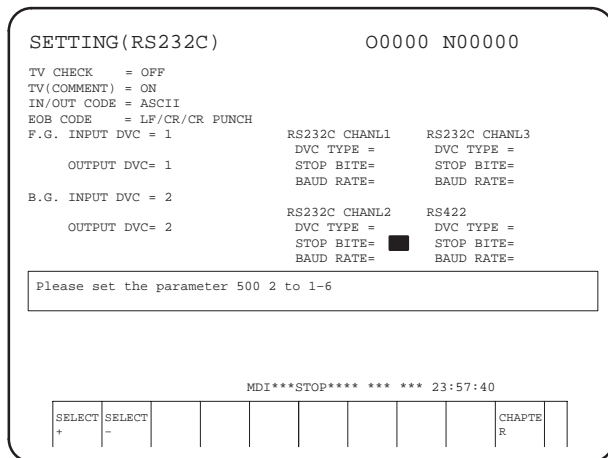

## Corresponding parameters

Item	Corresponding parameter/bit	Set value	
TV CHECK	Bit 0 (TVC) of parameter No. 0000	OFF (0) ON (1)	
TV (COMMENT)	Bit 1 (CTV) of parameter No. 0000	ON (0) OFF (1)	
14 : IN/OUT CODE 09 : I/O CODE	Bit 2 (ISP) of parameter No. 0000 Bit 4 (EIA) of parameter No. 0000	EIA : #4 =1 ISO : #4/#2 =0.0 ASCII : #4/#2 =0.1	
EOB CODE	Bit 3 (NCR) of parameter No. 0000	LF/CR/CR PUNCH (0) LF PUNCH (1)	
14 : INPUT DVC 09 : INP DVC	Foreground: Parameter No. 0020 Background: Parameter No. 0022	* * * * 1, 2, 3, 4, 9, 10, 13, 15, 16 Values with * can be specified only on the parameter screen.	
14 : OUTPUT DVC 09 : OUT DVC	Foreground: Parameter No. 0021 Background: Parameter No. 0023		
DVC TYPE	Parameter No. 5110, 5120, 5130, 5140, 5150, or 5160	1, 2, 3, 4, 5, 6, 7, 8,	
STOP BITS	Parameter No. 5111, 5121, 5131, 5141, 5151, or 5161	1, 2	
BAUD RATE	Parameter No. 5112, 5122, 5132, 5142, 5152, or 5162	1 to 12  1 to 7 can be specified only on the parameter screen.	
R e m o t e  b u f f e r	DVC TYPE	RS422 : Parameter No.5071 RS232C : Parameter No.5081	RS422 : 0, 8 RS232C : 0, 7, 8
	STOP BITS	RS422 : Parameter No.5072 RS232C : Parameter No.5082	1, 2
	BAUD RATE	RS422 : Parameter No.5073 RS232C : Parameter No.5083	RS422: 1 to 15 1 to 7 can be specified only on the parameter screen. RS232C: 1 to 12 1 to 7 can be specified only on the parameter screen.
	PROTOCOL	RS422 : Parameter No.5074 RS232C : Parameter No.5084	B : (1) EXT-B : (2) A : (3)*1 *1 Including extended protocol A HDLC (5) can be specified only on the parameter screen.



### 6.6.2 Outputting CNC parameters

See Section 6.3, "Outputting Parameters."

### 6.6.3 Outputting part programs

1. Enter EDIT mode.
2. Press the soft keys in the following order:



3. – When outputting all programs



- When outputting a specified program

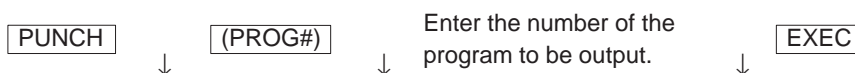

### 6.6.4 Outputting offset data

1. Enter MDI or EDIT mode.
2. Press the soft keys in the following order:

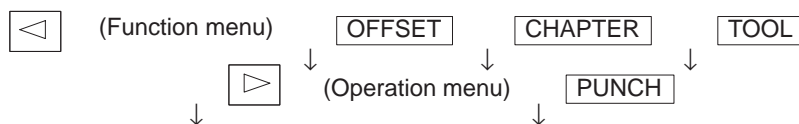

### 6.6.5 Inputting CNC parameters

See Section 6.2.2, "Specifying parameters through the reader/punch interface."

### 6.6.6 Inputting part programs

1. Enter EDIT mode.
2. Press the soft keys in the following order:

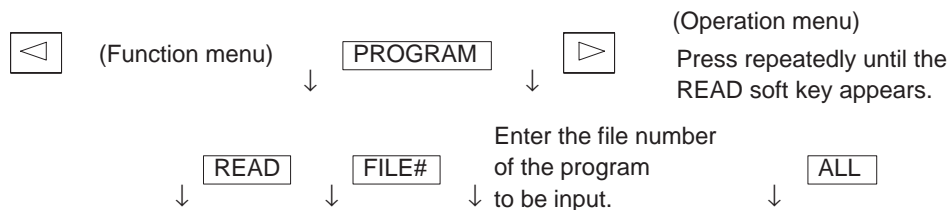

- Related parameters

	#7	#6	#5	#4	#3	#2	#1	#0
0011								NE8

- #0 NE8    0 : Programs No. 8000 to 8999 can be edited.  
           1 : Programs No. 8000 to 8999 cannot be edited.



## 7. CONFIGURATION OF THE PRINTED CIRCUIT BOARDS IN THE CONTROL UNIT

### 7.1 Power Unit Configuration

(1) Parts layout

Drawing number : A16B-1212-0471 (Power supply unit AI)

A16B-1212-0531 (Power supply unit BI)

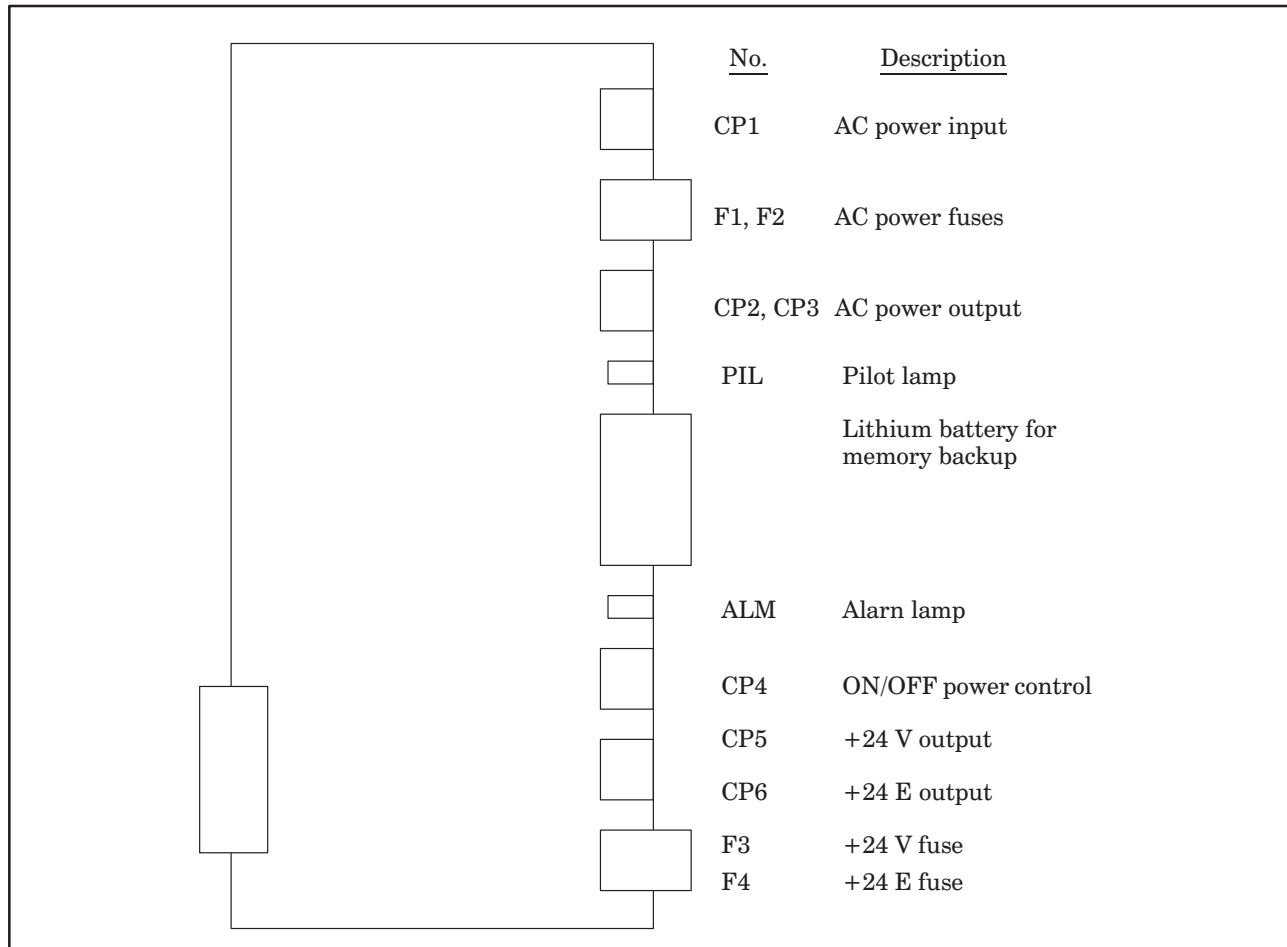

Fig. 7.1 (a) Power Unit Parts Layout

(2) Block diagram

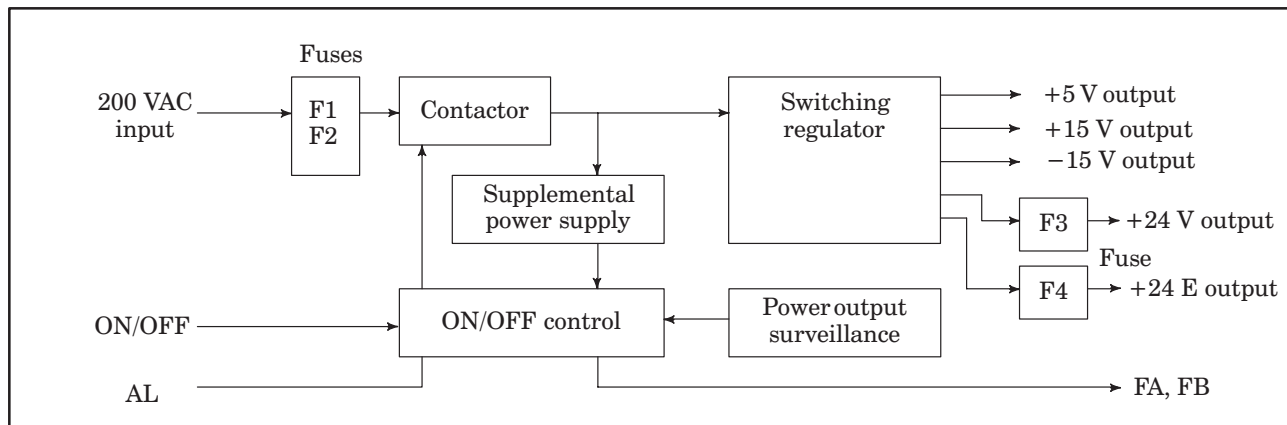

Fig. 7.1 (b) Power Unit Block Diagram

- (3) Adjustment  
No adjustment is needed.
- (4) LED display

Table 7.1 LED Display of the Power Unit

No.	LED display	NC status
1	PIL ■ (green)	200 VAC power is supplied to connector CP1.
2	ALM ■ (red)	Indicates that overvoltage, overcurrent, or voltage drop occurs at the output of the direct current power supply.

## 7.2 Configuration of the CPU Board (MAIN-B)

(1) Parts layout

Drawing number : A16B-2201-0320

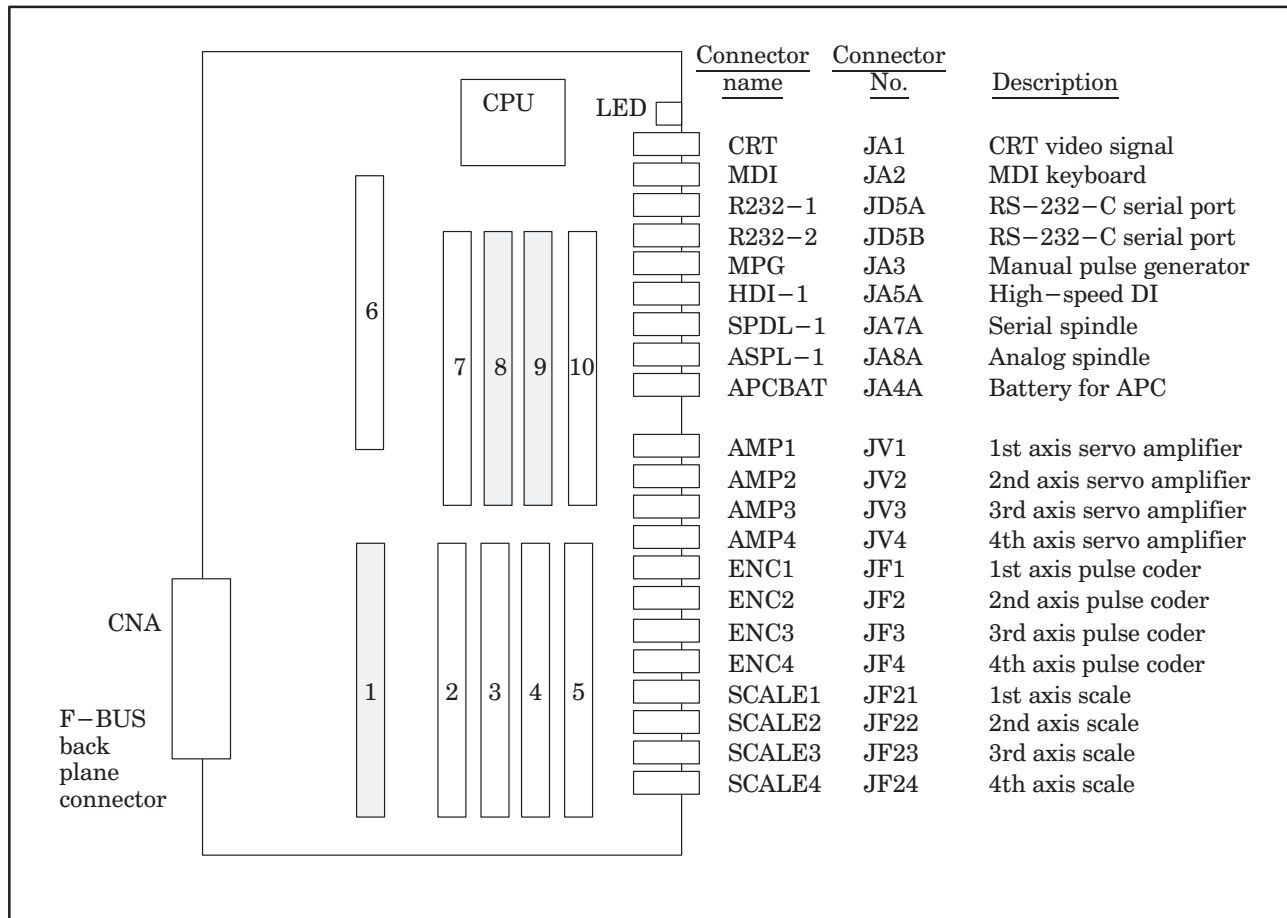

No.	Module name	Function outline
1	SRAM module	Part programs strage, RAM for parameter
2	Servo control module	3rd and 4th servo control
3	Servo control module	1st and 2nd servo control
4	Servo interface module	3rd and 4th amplifier, pulse coder interface
5	Servo interface module	1st and 2nd amplifier, pulse coder interface
6	DRAM module	RAM for CNC system
7	FLASH ROM module	FLASH-EPROM for CNC system
8	Spindle control module	System clear, battery backup control, spindle control, HDI interface etc....
9	Peripheral module	MDI, MPG, RS-232C, etc.... System timer, system clock, calendar clock
10	CRT control module	CRT display control

**NOTE** means the module connected power supply for battery backup. If the module are taken away carelessly, the backup are lost.

(2) Block diagram

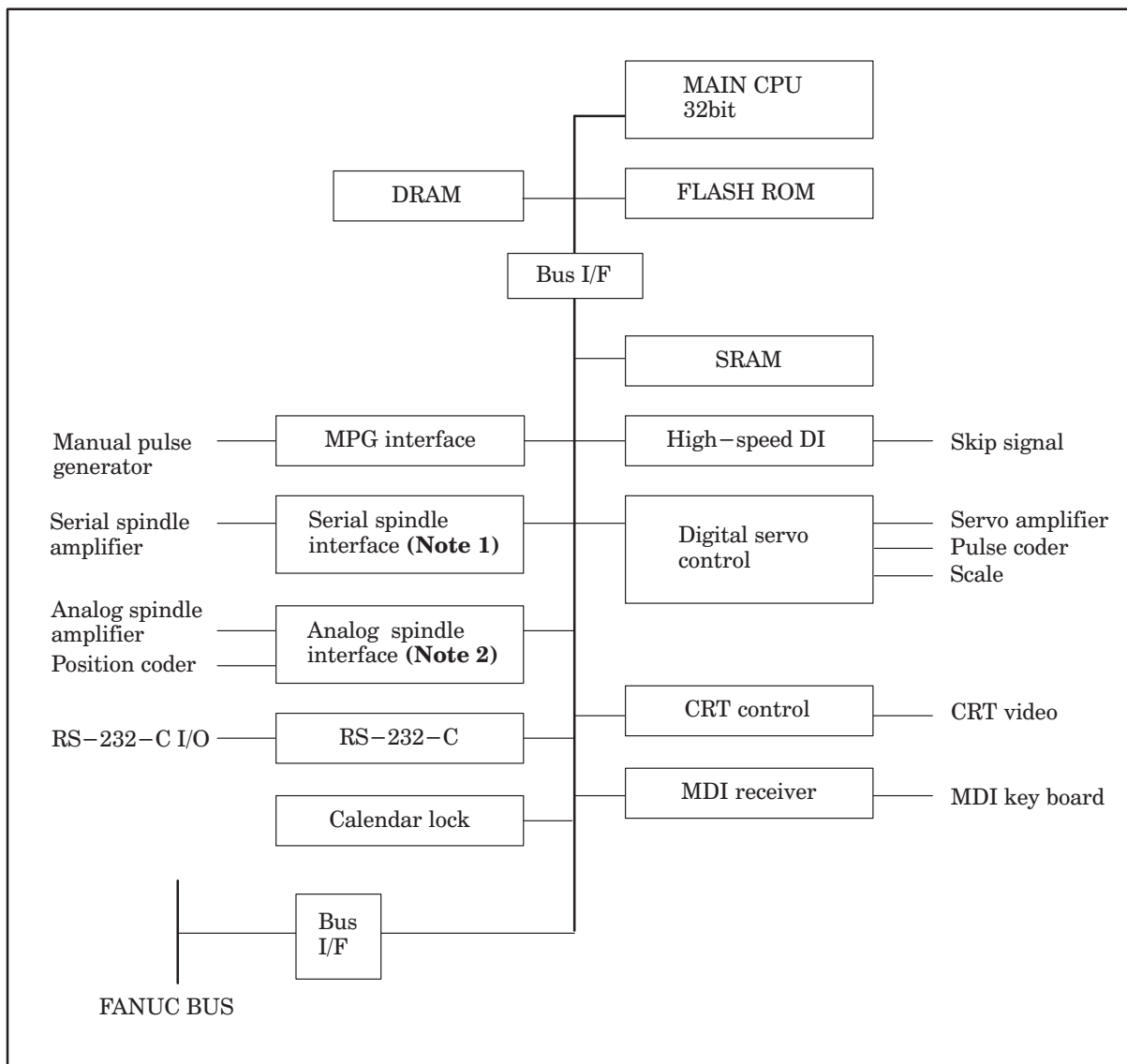

**NOTE 1** When the module of analog spindle is built in as a module of spindle control, the series interface is not there.

**NOTE 2** When a serial spindle module is mounted as the spindle control module, an analog spindle interface is not used.

(3) Adjustment

No adjustment is needed.

## (4) LED display

□ : off ■ : Lit ★ : Flashing

## 1. LED display transition when the power is turned on

No.	LED display	NC status
1	STATUS □□□□	Power-off
2	STATUS ■■■■	Initial state immediately after power-on
3	STATUS ■□□■	Beginning of activation of the CNC software
4	STATUS □□□■	End of CNC local RAM test
5	STATUS ■■■□	End of CNC local RAM clear
6	STATUS □■■□	FROM test in progress
7	STATUS ■■□□	End of key initialization. Logical slot setting is completed.
8	STATUS □□■□	End of CRT initialization. The CRT is ready for use.
9	STATUS ■■□■	Waiting for the completion of setting of the PC boards connected to the FANUC bus (1)
10	STATUS □■□■	IPL monitoring in progress
11	STATUS ■■□□	End of IPL
12	STATUS ■□■■	Waiting for the setting of *SYSFAIL
13	STATUS □□■■	Waiting for the completion of setting of the PC boards connected to the FANUC bus (2)
14	STATUS □■□□	Waiting for the completion of initialization of the servo
15	STATUS ■□□□	Normal state. The power-on sequence is ended.

## 2. LED display when an error occurs (STATUS LED)

No.	LED display	NC status
1	STATUS ★□□□	An error (1) occurred in the DRAM module of the CNC.
2	STATUS □★□□	An error occurred in the file SRAM.
3	STATUS ★★□□	An error (2) occurred in the DRAM module of the CNC.
4	STATUS □□★□	The CRT control module is not supported by the installed CNC software.
5	STATUS ★□★□	The main CPU board is not supported by the installed CNC software.
6	STATUS □★★□	An illegal PC board is installed in a slot of the FANUC bus. Two or more identical PC boards are installed when only one is permitted.
7	STATUS ★★★□	A system error (stack overflow) occurred.
8	STATUS □□□★	An illegal module is installed in the flash ROM module.
9	STATUS ★□□★	A flash ROM file configuration error (CNC area) occurred.
10	STATUS □★□★	A flash ROM file configuration error (PMC area) occurred.
16	STATUS □■■■	A system error (NMI to the CNC CPU) occurred.

## 3. LED display (STATUS LED) when an error occurs

No.	LED display	NC status
1	ALARM ■□□	Battery voltage for backup decreases.
2	ALARM □■□	SYSFAIL (A fault occurred on some modules of F-BUS)
3	ALARM ■■□	SERVO ALARM
4	ALARM □□■	SYSEMG (NMI occurred on some modules of F-BUS.)
5	ALARM ■□■	ABC ALARM (Parity alarm on FILE SRAM, A fault of peripheral bus)
6	ALARM □■■	Parity alarm occurred on DRAM area



### 7.3 Configuration of the Main CPU Board (MAIN-A)

(1) Parts layout

Drawing number : A16B-2201-0300

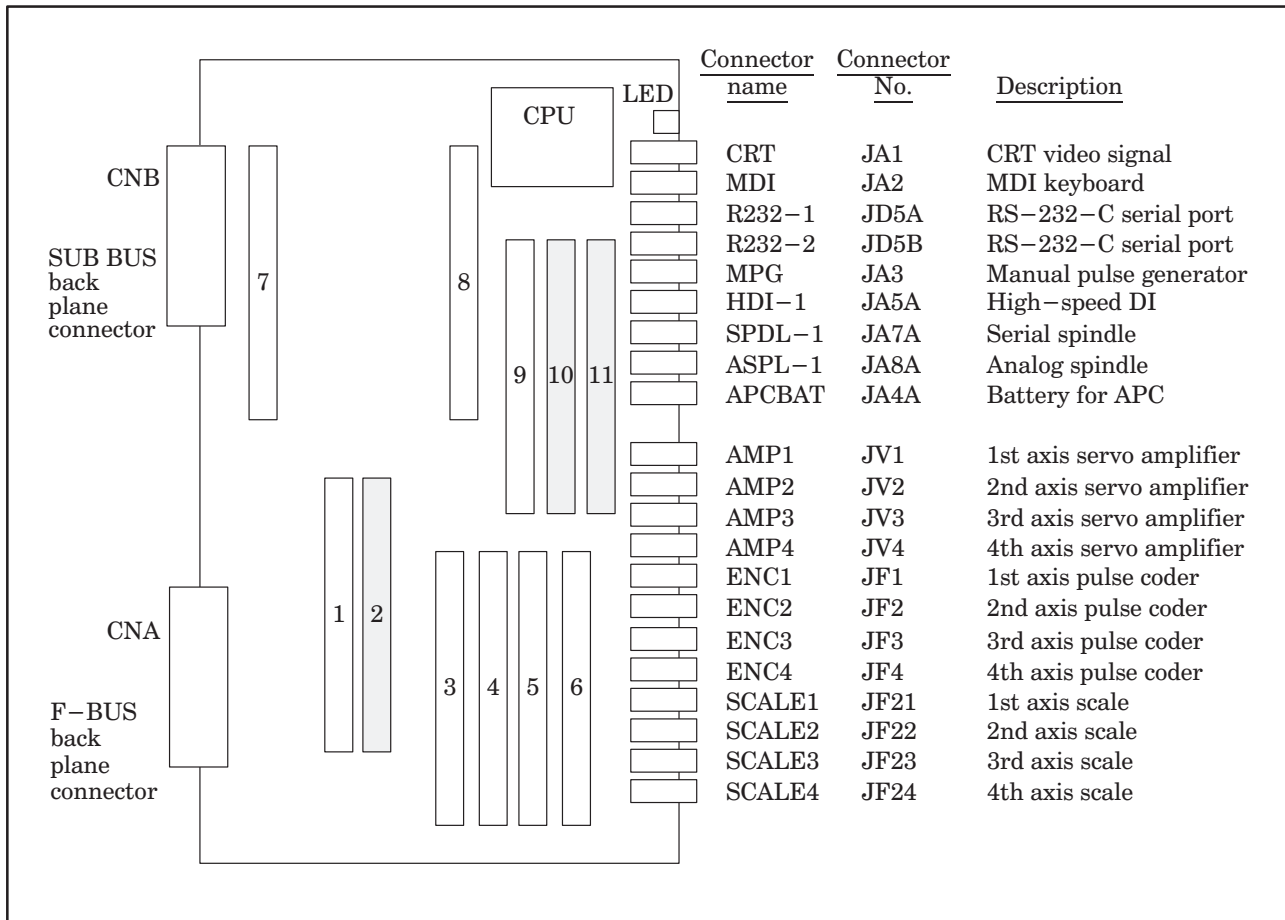

No.	Module name	Function outline
1	CRT control module	CRT display control
2	SRAM module	Part program storage, RAM for parameter
3	Servo control module	3rd and 4th servo control
4	Servo control module	1st and 2nd servo control
5	Servo interface module	3rd and 4th amplifier, pulse coder interface
6	Servo interface module	1st and 2nd amplifier, pulse coder interface
7	High-speed SRAM module	High-speed RAM for CNC system
8	DRAM module	RAM for CNC system
9	FLASH ROM module	FLASH-EPROM for CNC system
10	Spindle control module	System clear, battery backup control, spindle control, HDI interface etc....
11	Peripheral module	MDI, MPG, RS-232C, etc.... interface System timer, system clock, calendar clock

**NOTE**  means the module connected power supply for battery backup. If the module are taken away carelessly, the backup are lost.

## (2) Block diagram

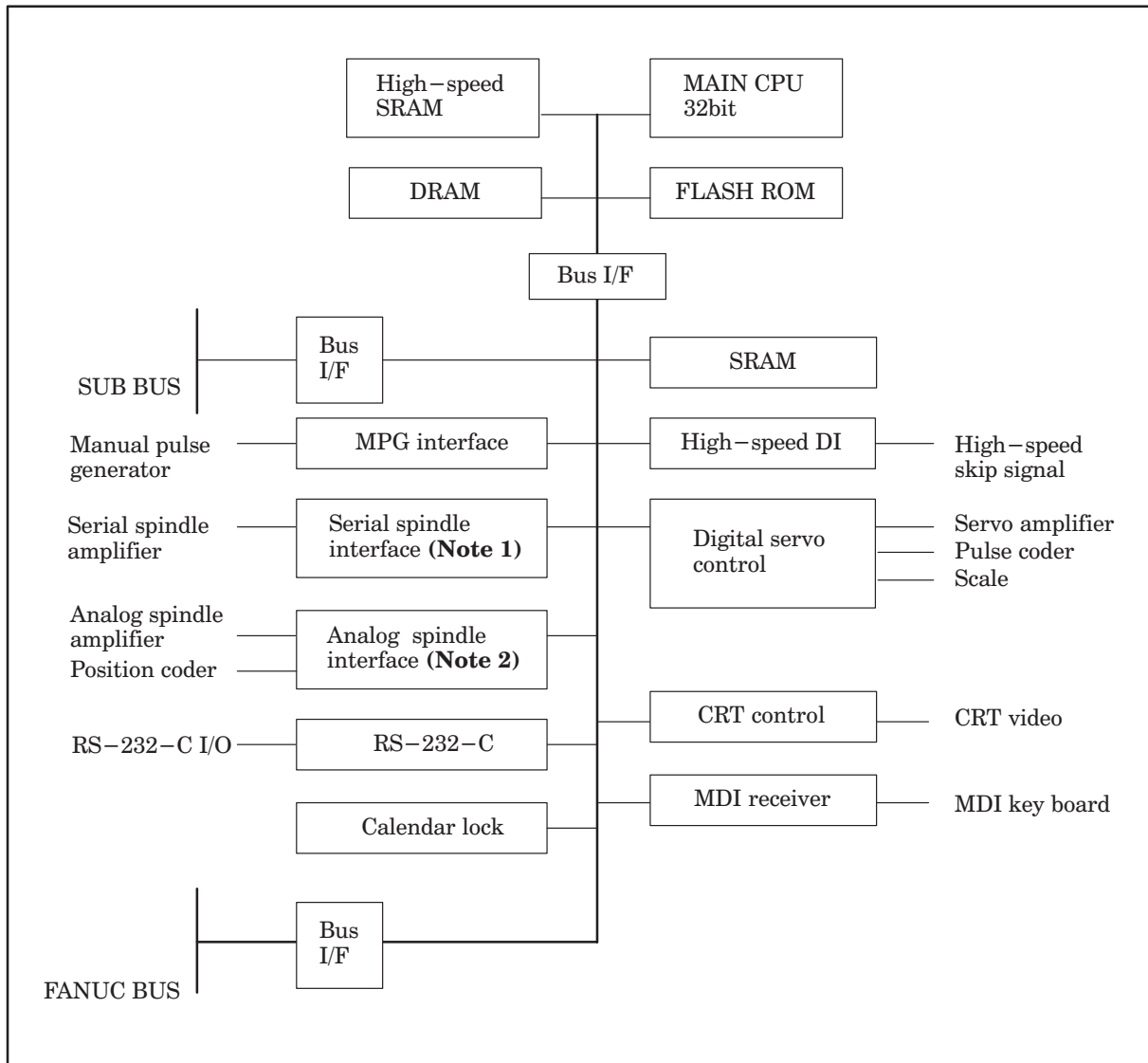

**NOTE 1** When the module of analog spindle is built in as module of spindle control, the serial spindle interface is not there.

**NOTE 2** When a serial spindle module is mounted as the spindle control module, an analog spindle interface is not used.

## (3) Adjustment

No adjustment is needed.

## (4) LED display

□ : Not lit ■ : Lit ★ : Blinking

STATUS LEDs are green. ALARM LEDs are red.

## 1. LED display transition when the power is turned on (STATUS LED)

No.	LED display	NC status
1	STATUS □□□□	Power-off
2	STATUS ■■■■	Initial state immediately after power-on
3	STATUS ■□□■	Beginning of activation of the CNC software
4	STATUS □□□■	End of CNC local RAM test
5	STATUS ■■■□	End of CNC local RAM clear
6	STATUS □■■□	FROM test in progress
7	STATUS ■□■□	End of key initialization. Logical slot setting is completed.
8	STATUS □□■□	End of CRT initialization. The CRT is ready for use.
9	STATUS ■■□■	Waiting for the completion of setting of the PC boards connected to the FANUC bus (1)
10	STATUS □■□■	IPL monitoring in progress
11	STATUS ■■□□	End of IPL
12	STATUS ■□■□	Waiting for the setting of *SYSFAIL
13	STATUS □□■□	Waiting for the completion of setting of the PC boards connected to the FANUC bus (2)
14	STATUS □■□□	Waiting for the completion of initialization of the servo
15	STATUS ■□□□	Normal state. The power-on sequence is ended.

## 2. LED display when an error occurs (STATUS LED)

No.	LED display	NC status
1	STATUS ★□□□	An error (1) occurred in the high-speed SRAM or DRAM module of the CNC.
2	STATUS □★□□	An error occurred in the file SRAM.
3	STATUS ★★□□	An error (2) occurred in the high-speed SRAM or DRAM module of the CNC.
4	STATUS □□★□	The CRT control module is not supported by the installed CNC software.
5	STATUS ★□★□	The main CPU board is not supported by the installed CNC software.
6	STATUS □★★□	An illegal PC board is installed in a slot of the FANUC bus. Two or more identical PC boards are installed when only one is permitted.
7	STATUS ★★★□	A system error (stack overflow) occurred.
8	STATUS □□□★	An illegal module is installed in the flash ROM module.
9	STATUS ★□□★	A flash ROM file configuration error (CNC area) occurred.
10	STATUS □★□★	A flash ROM file configuration error (PMC area) occurred.
16	STATUS □■■■	A system error (NMI to the CNC CPU) occurred.

## 3. LED display when an error occurs (ALARM LED)

No.	LED display	NC status
1	ALARM ■□□	The voltage of the backup battery has fallen below the specified minimum level.
2	ALARM □■□	SYFAIL (fault in a module on the F-bus) occurred.
3	ALARM ■■□	A servo alarm occurred.
4	ALARM □□■	SYSEMG (NMI in a module on the F-bus) occurred.
5	ALARM ■□■	An ABC alarm (parity alarm in the file SRAM, fault in the peripheral bus, SUB bus, or FANUC bus) occurred.
6	ALARM □■■	A parity alarm occurred in the DRAM module.
7	ALARM ■■■	A parity alarm occurred in the high-speed SRAM module.

## 7.4 Configuration of the Upgraded Main CPU Board (MAIN-C)

(1) Parts layout

Drawing number : A16B-3200-0060

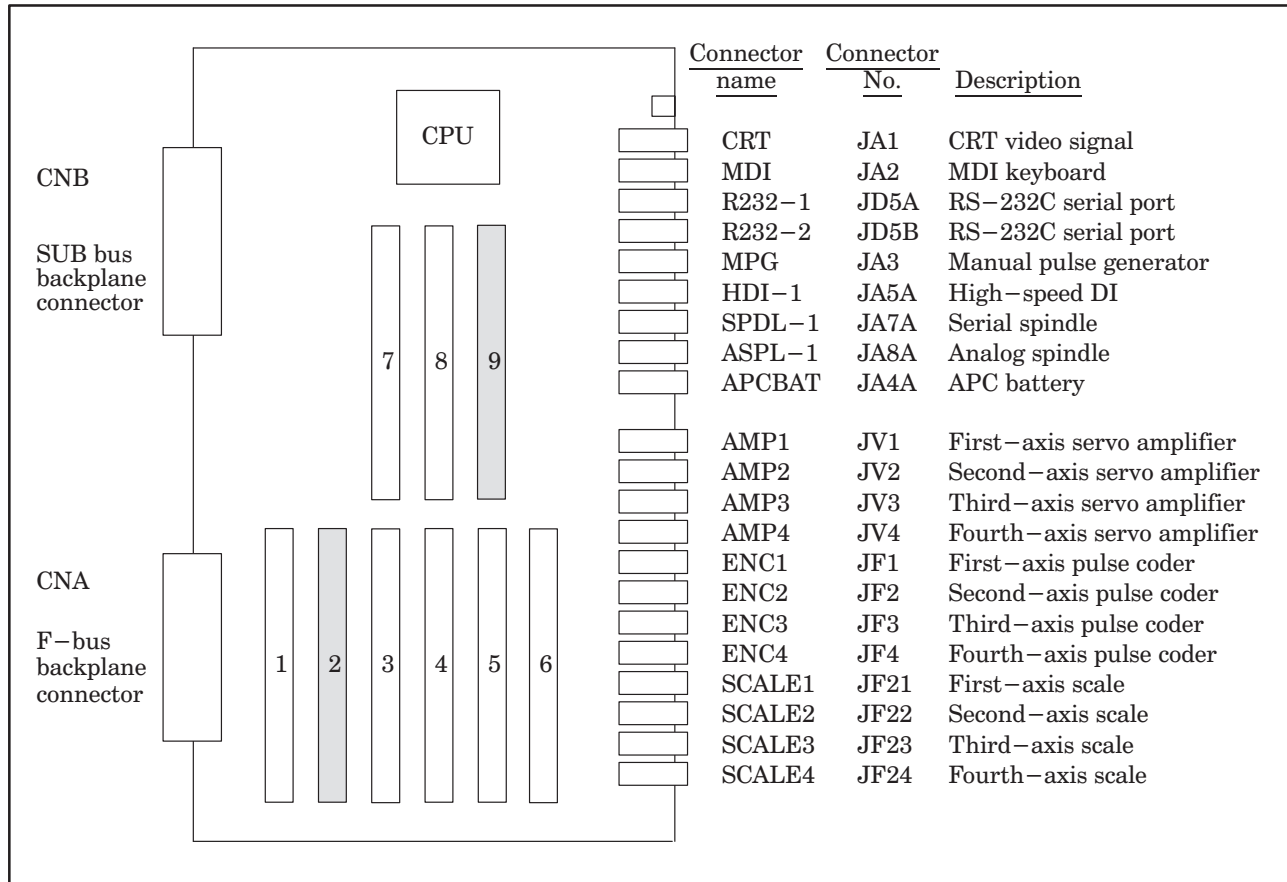

No.	Module name	Function outline
1	CRT control module	CRT display control
2	SRAM module	Part program storage, RAM for parameters
3	Servo control module	Third-axis and fourth-axis servo control
4	Servo control module	First-axis and second-axis servo control
5	Servo interface module	Third-axis and fourth-axis amplifier, pulse coder interface
6	Servo interface module	First-axis and second-axis amplifier, pulse coder interface
7	DRAM module	RAM for CNC system
8	Flash ROM module	Flash EPROM for CNC system
9	Spindle control module	System clear, battery backup, spindle control, HDI interface, etc.

**NOTE** Power for the battery backup is supplied to the module in the shaded box. If the module is disconnected, all data will be lost.

(2) Block diagram

See (2) in Section 7.2.

(3) Adjustment

No adjustment is needed.

## (4) LED display

□ : Not lit ■ : Lit ★ : Blinking

STATUS LEDs are green. ALARM LEDs are red.

## 1. LED display transition when the power is turned on (STATUS LED)

No.	LED display	NC status
1	STATUS □□□□	Power-off
2	STATUS ■■■■	Initial state immediately after power-on
3	STATUS ■□□■	Beginning of activation of the CNC software
4	STATUS □□□■	End of CNC local RAM test
5	STATUS ■■■□	End of CNC local RAM clear
6	STATUS □■■□	FROM test in progress
7	STATUS ■□■□	End of key initialization. Logical slot setting is completed.
8	STATUS □□■□	End of CRT initialization. The CRT is ready for use.
9	STATUS ■■□■	Waiting for the completion of setting of the PC boards connected to the FANUC bus (1)
10	STATUS □■□■	IPL monitoring in progress
11	STATUS ■■□□	End of IPL
12	STATUS ■□■□	Waiting for the setting of *SYSFAIL
13	STATUS □□■□	Waiting for the completion of setting of the PC boards connected to the FANUC bus (2)
14	STATUS □■□□	Waiting for the completion of initialization of the servo
15	STATUS ■□□□	Normal state. The power-on sequence is ended.

## 2. LED display when an error occurs (STATUS LED)

No.	LED display	NC status
1	STATUS ★□□□	An error (1) occurred in the DRAM module of the CNC.
2	STATUS □★□□	An error occurred in the file SRAM.
3	STATUS ★★□□	An error (2) occurred in the DRAM module of the CNC.
4	STATUS □□★□	The CRT control module is not supported by the installed CNC software.
5	STATUS ★□★□	The main CPU board is not supported by the installed CNC software.
6	STATUS □★★□	An illegal PC board is installed in a slot of the FANUC bus. Two or more identical PC boards are installed when only one is permitted.
7	STATUS ★★★□	A system error (stack overflow) occurred.
8	STATUS □□□★	An illegal module is installed in the flash ROM module.
9	STATUS ★□□★	A flash ROM file configuration error (CNC area) occurred.
10	STATUS □★□★	A flash ROM file configuration error (PMC area) occurred.
16	STATUS □■■■	A system error (NMI to the CNC CPU) occurred.

## 3. LED display when an error occurs (ALARM LED)

No.	LED display	NC status
1	ALARM ■□□	The voltage of the backup battery has fallen below the specified minimum level.
2	ALARM □■□	SYFAIL (fault in a module on the F-bus) occurred.
3	ALARM ■■□	A servo alarm occurred.
4	ALARM □□■	SYSEMG (NMI in a module on the F-bus) occurred.
5	ALARM ■□■	An ABC alarm (parity alarm in the file SRAM, fault in the peripheral bus, multiaxis bus, or FANUC bus) occurred.
6	ALARM □■■	A parity alarm occurred in the DRAM module.
7	ALARM ■■■	A parity alarm occurred in the shared RAM on the SUB board.

## 7.5 Configuration of the High-Speed Multiaxis Main CPU Board (MAX MAIN-A)

(1) Parts layout

Drawing number : A16B-2201-0340

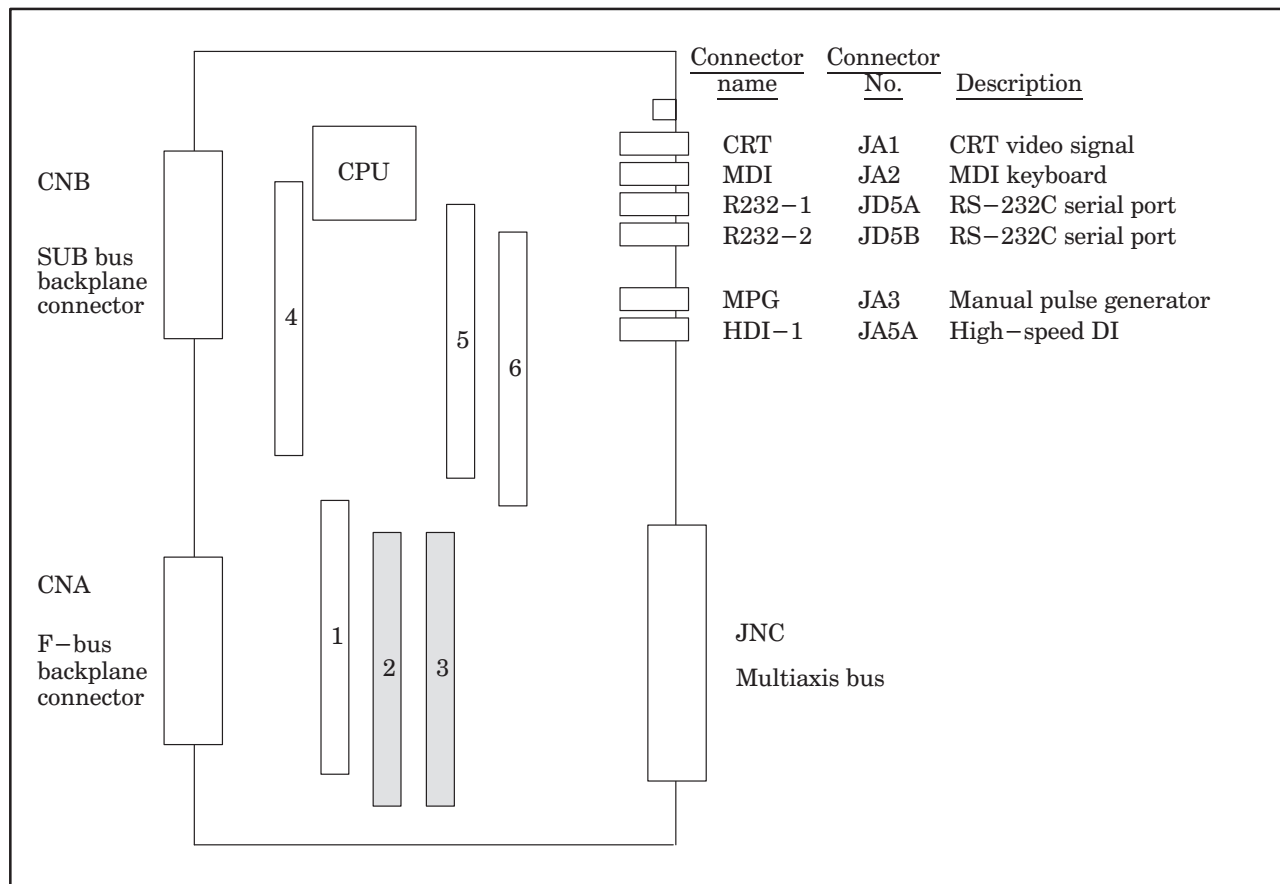

No.	Module name	Function outline
1	CRT control module	CRT display control
2	SRAM module	Part program storage, RAM for parameters
3	Peripheral module	Interface such as MDI, MPG, and RS-232C, system timer, system clock, calendar clock
4	High-speed SRAM module	High-speed RAM for CNC system
5	DRAM module	RAM for CNC system
6	FLASH ROM module	FLASH EPROM for CNC system

**NOTE** Power for the battery backup is supplied to the module in the shaded box. If the module is disconnected, all data will be lost.



(2) Block diagram

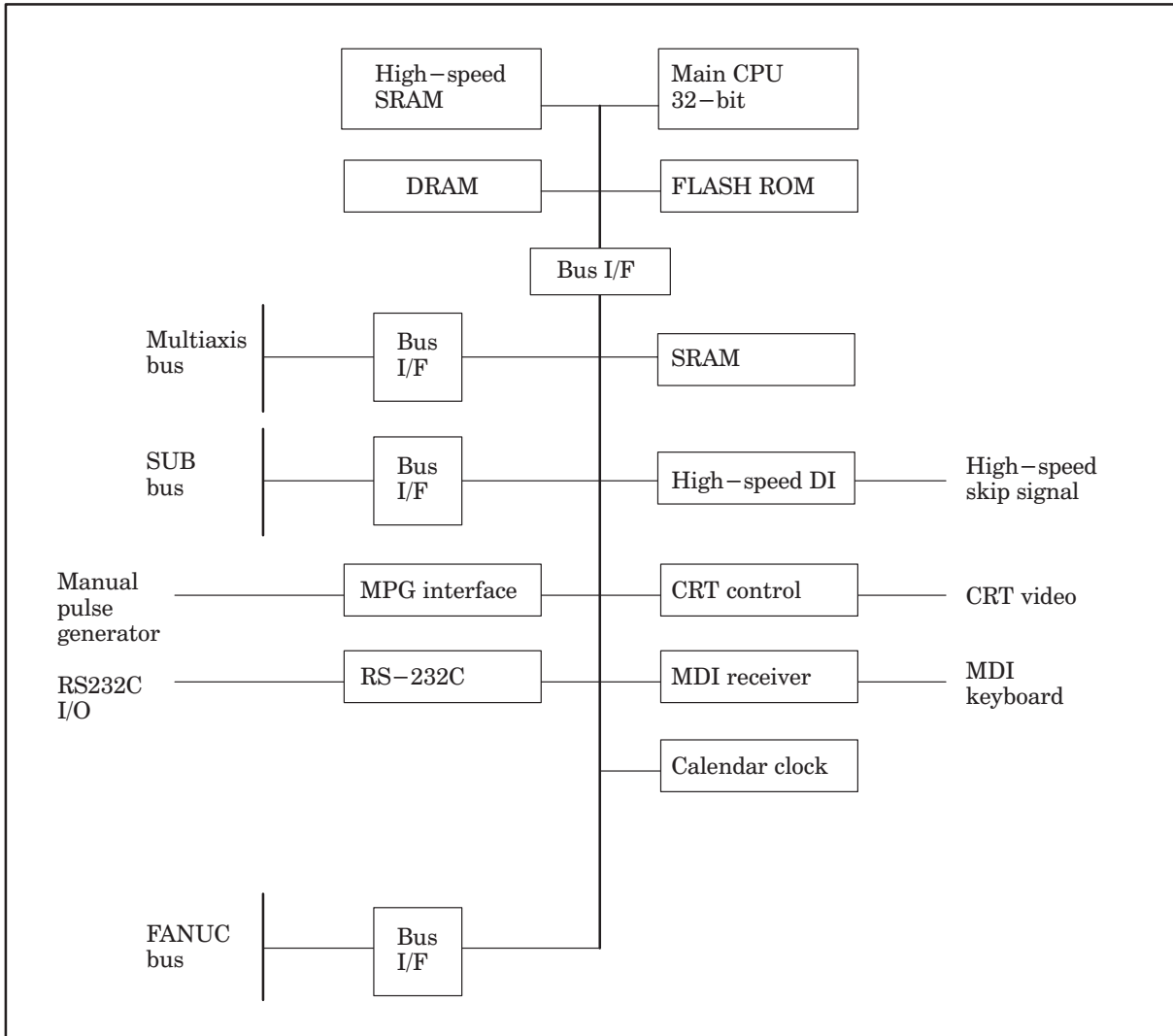

(3) Adjustment

No adjustment is needed.

Multi-axis main board

## (4) LED display

□ : Not lit ■ : Lit ★ : Blinking

STATUS LEDs are green. ALARM LEDs are red.

## 1. LED display transition when the power is turned on (STATUS LED)

No.	LED display	NC status
1	STATUS □□□□	Power-off
2	STATUS ■■■■	Initial state immediately after power-on
3	STATUS ■□□■	Beginning of activation of the CNC software
4	STATUS □□□■	End of CNC local RAM test
5	STATUS ■■■□	End of CNC local RAM clear
6	STATUS □■■□	FROM test in progress
7	STATUS ■□■□	End of key initialization. Logical slot setting is completed.
8	STATUS □□■□	End of CRT initialization. The CRT is ready for use.
9	STATUS ■■□■	Waiting for the completion of setting of the PC boards connected to the FANUC bus (1)
10	STATUS □■□■	IPL monitoring in progress
11	STATUS ■■□□	End of IPL
12	STATUS ■□■■	Waiting for the setting of *SYSFAIL
13	STATUS □□■■	Waiting for the completion of setting of the PC boards connected to the FANUC bus (2)
14	STATUS □■□□	Waiting for the completion of initialization of the servo
15	STATUS ■□□□	Normal state. The power-on sequence is ended.

## 2. LED display when an error occurs (STATUS LED)

No.	LED display	NC status
1	STATUS ★□□□	An error (1) occurred in the high-speed SRAM or DRAM module of the CNC.
2	STATUS □★□□	An error occurred in the file SRAM.
3	STATUS ★★□□	An error (2) occurred in the high-speed SRAM or DRAM module of the CNC.
4	STATUS □□★□	The CRT control module is not supported by the installed CNC software.
5	STATUS ★□★□	The main CPU board is not supported by the installed CNC software.
6	STATUS □★★□	An illegal PC board is installed in a slot of the FANUC bus. Two or more identical PC boards are installed when only one is permitted.
7	STATUS ★★★□	A system error (stack overflow) occurred.
8	STATUS □□□★	An illegal module is installed in the flash ROM module.
9	STATUS ★□□★	A flash ROM file configuration error (CNC area) occurred.
10	STATUS □★□★	A flash ROM file configuration error (PMC area) occurred.
16	STATUS □■■■■	A system error (NMI to the CNC CPU) occurred.

## 3. LED display when an error occurs (ALARM LED)

No.	LED display	NC status
1	ALARM ■□□	The voltage of the backup battery has fallen below the specified minimum level.
2	ALARM □■□	SYSFAIL (fault in a module on the F-bus) occurred.
3	ALARM ■■□	A servo alarm occurred.
4	ALARM □□■	SYSEMG (NMI in a module on the F-bus) occurred.
5	ALARM ■□■	An ABC alarm (parity alarm in the file SRAM, fault in the peripheral bus, SUB bus, multiaxis bus, or FANUC bus) occurred.
6	ALARM □■■	A parity alarm occurred in the DRAM module.
7	ALARM ■■■	A parity alarm occurred in the high-speed SRAM module.

## 7.6 Configuration of the PMC-NA Board

(1) Parts layout

Drawing number : A16B-2201-0371 (PMC-NA board without conversational function)

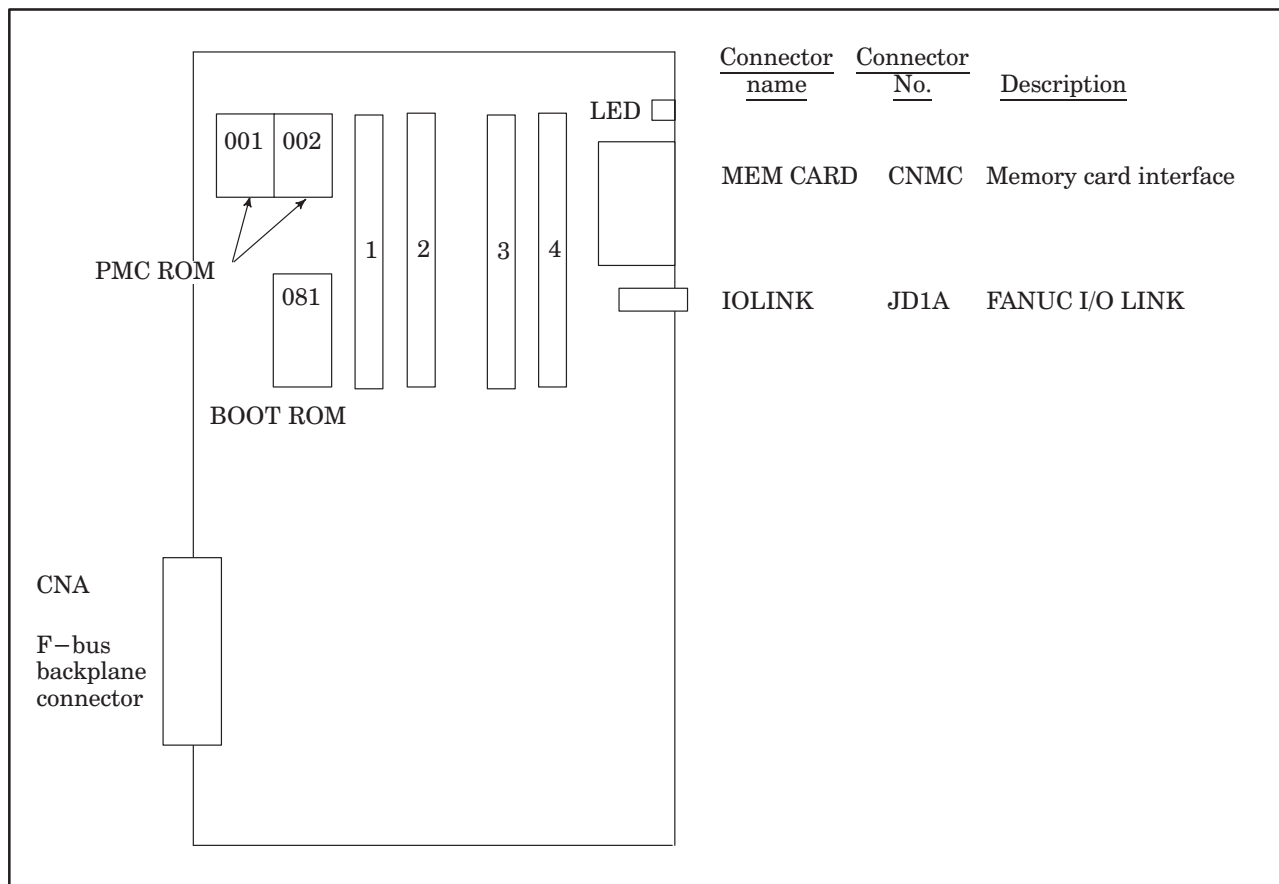

No.	Module name	Function outline
1	PMC CPU module	CPU module for PMC-NA
2	PMC engine module	PMC operation control, I/O Link control
3	DRAM module	Work RAM for PMC-NA
4	FLASH ROM module	FLASH EPROM

(2) Block diagram

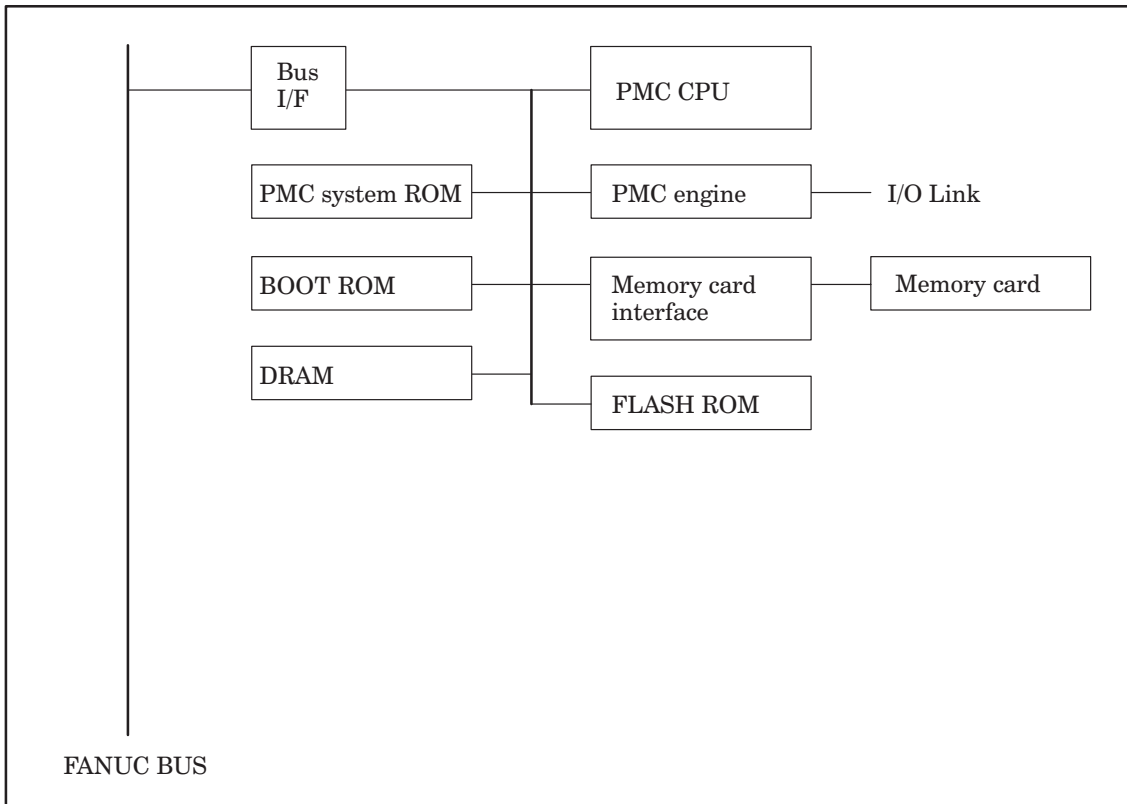

(3) Adjustment

No adjustment is needed.

(4) LED display

Of the STATUS LEDs provided at the top on the front edge of the PMC-NA board, only two are valid as shown on the right:

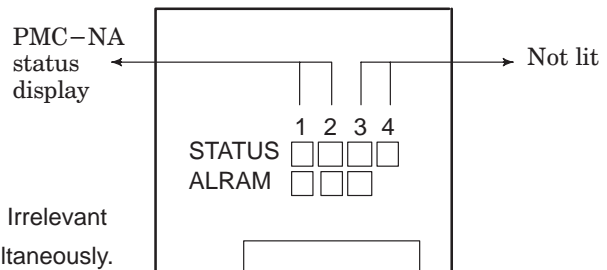

Legend

- : Not lit    ■ : Lit    ★☆ : Blinking    ◆ : Irrelevant
- ★★ represents that the two LEDs blink simultaneously.
- ★☆ represents that the two LEDs blink alternately.

(a) STATUS LED display for the PMC-NA function

1. STATUS LED display transition when the power is turned on

No.	LED display	NC status
1	STATUS □□□□	Power-off
2	STATUS ■■□□	Initial state immediately after power-on or the state in which the PMC CPU is not operating
3	STATUS □■□□	Initial state. PMC initialization is in progress.
4	STATUS ■□□□	Initial state PMC ROM parity check, transfer of a Ladder or PASCAL program to DRAM in progress, SLC initialization in progress (IPL is completed in the CNC and the NC ready status is awaited.)
5	STATUS □□□□	Normal state

## 2. STATUS LED display when an error occurs

No.	LED display	NC status
1	STATUS ★★□□	An error occurred in another PC board.
2	STATUS ■★□□	An error occurred during transfer from or to DI/DO. The DRAM module to be installed on the main CPU is defective.
3	STATUS ★■□□	A RAM parity error occurred in the PMC engine module (upon accessing the BOC).
4	STATUS □★□□	A RAM parity error occurred in the PMC engine module or PMC DRAM module (upon accessing the CPU).
5	STATUS ★y□□	A failure (BUS ERR, ADDR ERR, ILL INST, ZERO DIV, etc.) occurred in the PMC function. The PMC ROM is defective.

## (b) ALARM LED display

No.	LED display	NC status
1	ALARM □■□	The PMC CPU asserts SYSFAIL.
2	ALARM ■■□	The PMC CPU is in the stop state.
3	ALARM □□■	An error (SLC error) occurred during data transfer to or from DI/DO.
4	ALARM ■■■	A RAM (RAM on the PMC engine module or PMC DRAM module) parity error occurred in the PMC.

## 7.7 Configuration of the PMC-NA Board with or without the Conversational Function

### (1) Parts layout

Drawing numbers : A16B-2201-0390 (PMC-NA board with conversational function)

A16B-2201-0391 (PMC-NA board without conversational function)

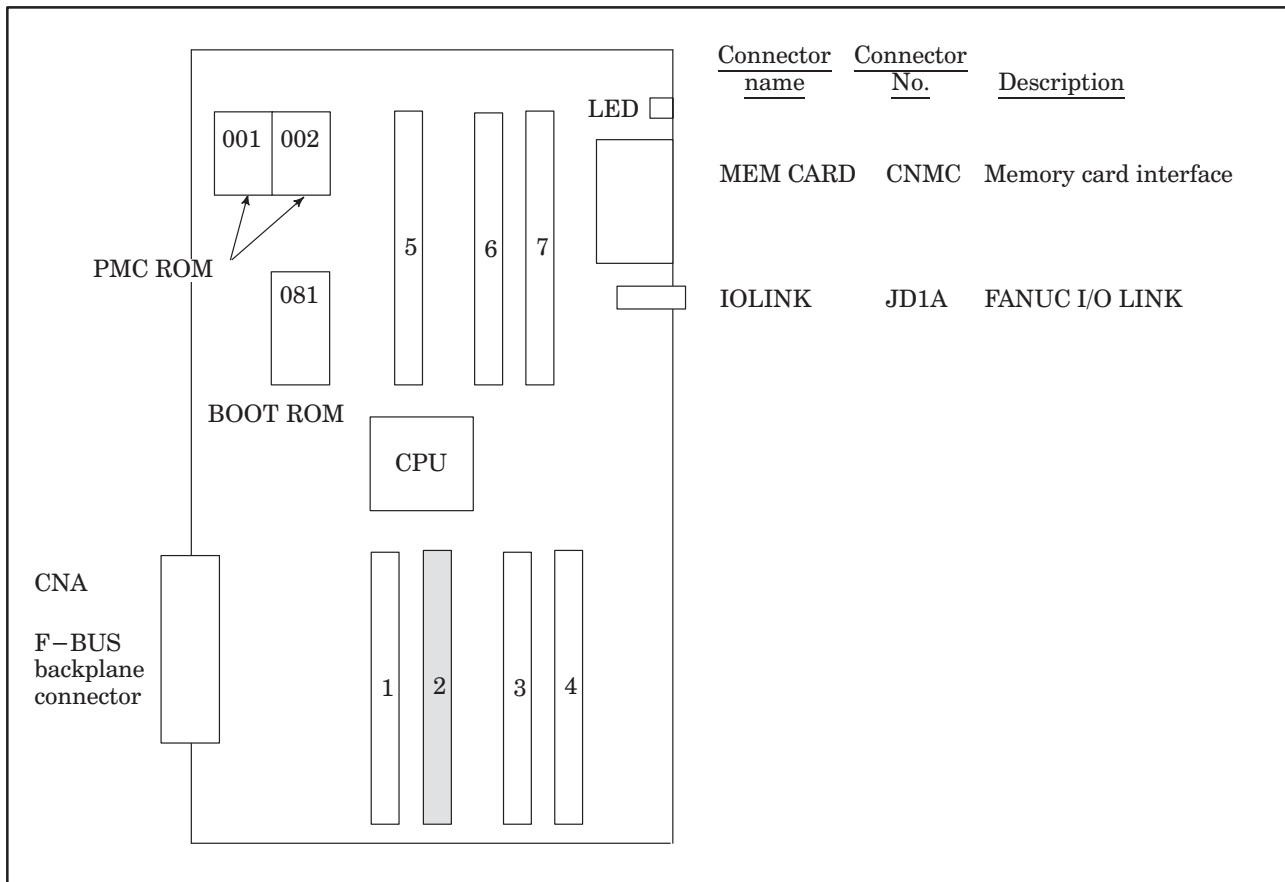

No.	Module name	Function outline
1	Conversational CPU module	CPU module for the conversational function
2	SRAM module	Sub-memory for the conversational function
3	DRAM module	Work DRAM for the conversational function
4	ROM module	System ROM for the conversational function
5	PMC engine module	PMC operation control, I/O Link control
6	DRAM module	Work RAM for PMC-NA
7	FLASH ROM module	FLASH EPROM

**NOTE** Power for the battery backup is supplied to the module in the shaded box. If the module is disconnected, all data will be lost.

(2) Block diagram

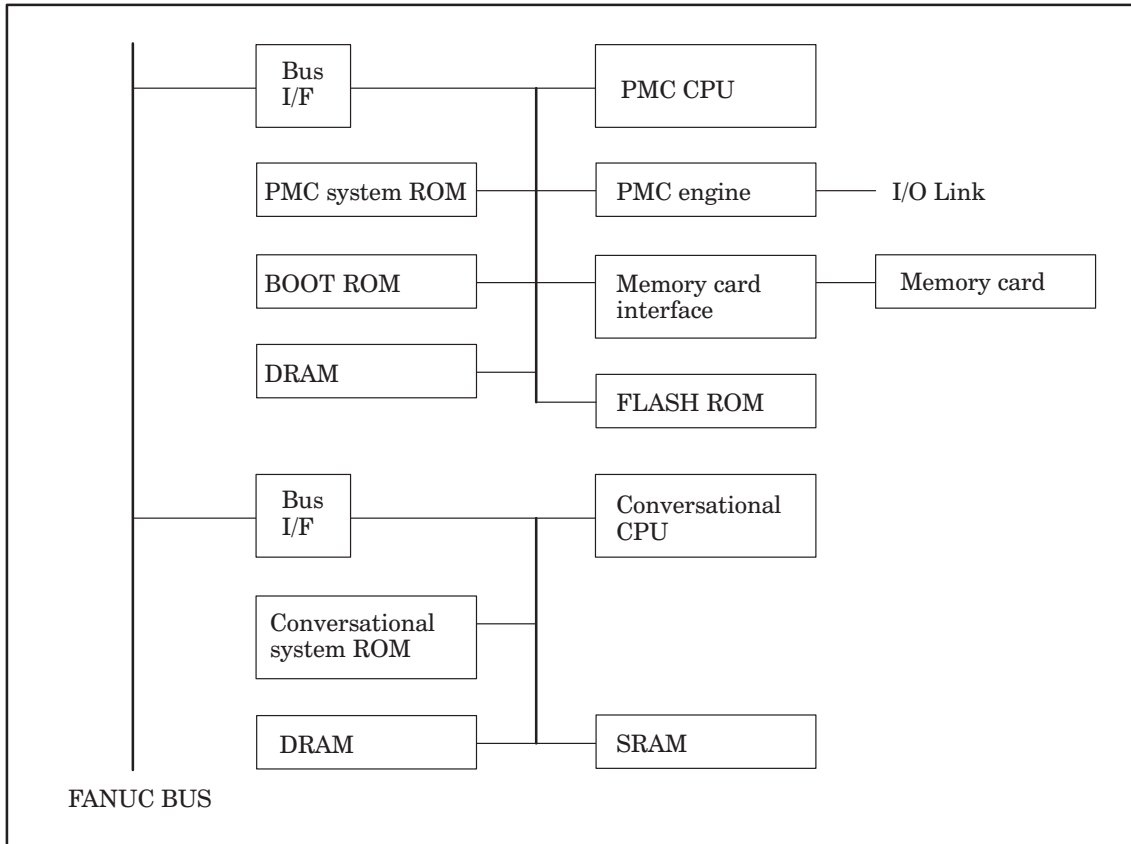

(3) Adjustment

No adjustment is needed.

(4) LED display

The STATUS LEDs at the top of the front of the PMC-NA board having the conversational function are used for independent functions, as shown on the right.

Legend

- : Not lit    ■ : Lit    ★★ : Blinking    ◆ : Irrelevant
- ★★ represents that the two LEDs blink simultaneously.
- ★☆ represents that the two LEDs blink alternately.

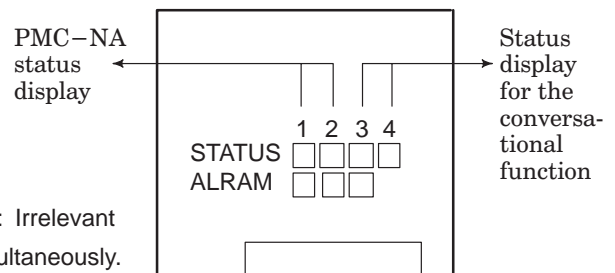

(a) LED display for the PMC-NA function

1. STATUS LED display transition when the power is turned on

No.	LED display	NC status
1	STATUS □□□□	Power-off
2	STATUS ■■◆◆	Initial state immediately after power-on or the state in which the PMC CPU is not operating
3	STATUS □■◆◆	Initial state. PMC initialization is in progress.
4	STATUS ■□◆◆	Initial state PMC ROM parity check, transfer of a Ladder or PASCAL program to DRAM in progress, SLC initialization in progress (IPL is completed in the CNC and the NC ready status is awaited.)
5	STATUS □□◆◆	Normal state



## 2. STATUS LED display for the PMC-NA function upon the occurrence of an error

No.	LED display	NC status
1	STATUS ★★◆◆	An error occurred in another PC board.
2	STATUS ■★◆◆	An error occurred during transfer to or from DI/DO. Alternatively, the DRAM module on the main CPU board is defective.
3	STATUS ★■◆◆	A RAM parity error occurred in the PMC engine module (upon accessing the BOC).
4	STATUS □★◆◆	A RAM parity error occurred in the PMC engine module or PMC DRAM module (upon accessing the CPU).
5	STATUS ★y◆◆	A failure (BUS ERR, ADDR ERR, ILL INST, ZERO DIV, etc.) occurred in the PMC function. The PMC ROM is defective.

## (b) STATUS LED display for the conversational function (TF, TTF, MF)

## 1. STATUS LED display transition when the power is turned on

No.	LED display	NC status
1	STATUS □□□□	Power-off
2	STATUS ◆◆□■	Waiting for initialization of the main CPU (waiting for ID setting)
3	STATUS ◆◆■□	Initialized state
4	STATUS ◆◆□□	Normal state

## 2. STATUS LED display for the conversational function upon the occurrence of an error (TF, TTF)

No.	LED display	NC status
1	STATUS ◆◆★★	An error occurred in another PC board.
2	STATUS ◆◆□★	A RAM parity error occurred on the PC board for the conversational function.
3	STATUS ◆◆★☆	A defective ROM module was detected on the PC board for the conversational function.
4	STATUS ◆◆■□	The CPU for the conversational function performed illegal processing.

## 3. STATUS LED display for the conversational function when an error occurs (MF)

No.	LED display	NC status
1	STATUS ◆◆★★	An error occurred in another PC board or the CPU for the conversational function.

## (c) ALARM LED display

No.	LED display	NC status
1	ALARM ■□□	The CPU for the conversational function asserts SYSFAIL.
2	ALARM □■□	The PMC CPU asserts SYSFAIL.
3	ALARM ■■□	The PMC CPU is in the stop state.
4	ALARM □□■	An error (SLC error) occurred during data transfer to or from DI/DO.
5	ALARM ■■■	A RAM (RAM on the PMC engine module or PMC DRAM module) parity error occurred in the PMC.

## 7.8 Configuration of the PMC-NB Board with or without the Conversational Function

### (1) Parts layout

Drawing numbers : A16B-2201-0810 (PMC-NB board with conversational function)  
 A16B-2201-0811 (PMC-NB board without conversational function)  
 A16B-2201-0381 (PMC-NB board without conversational function)

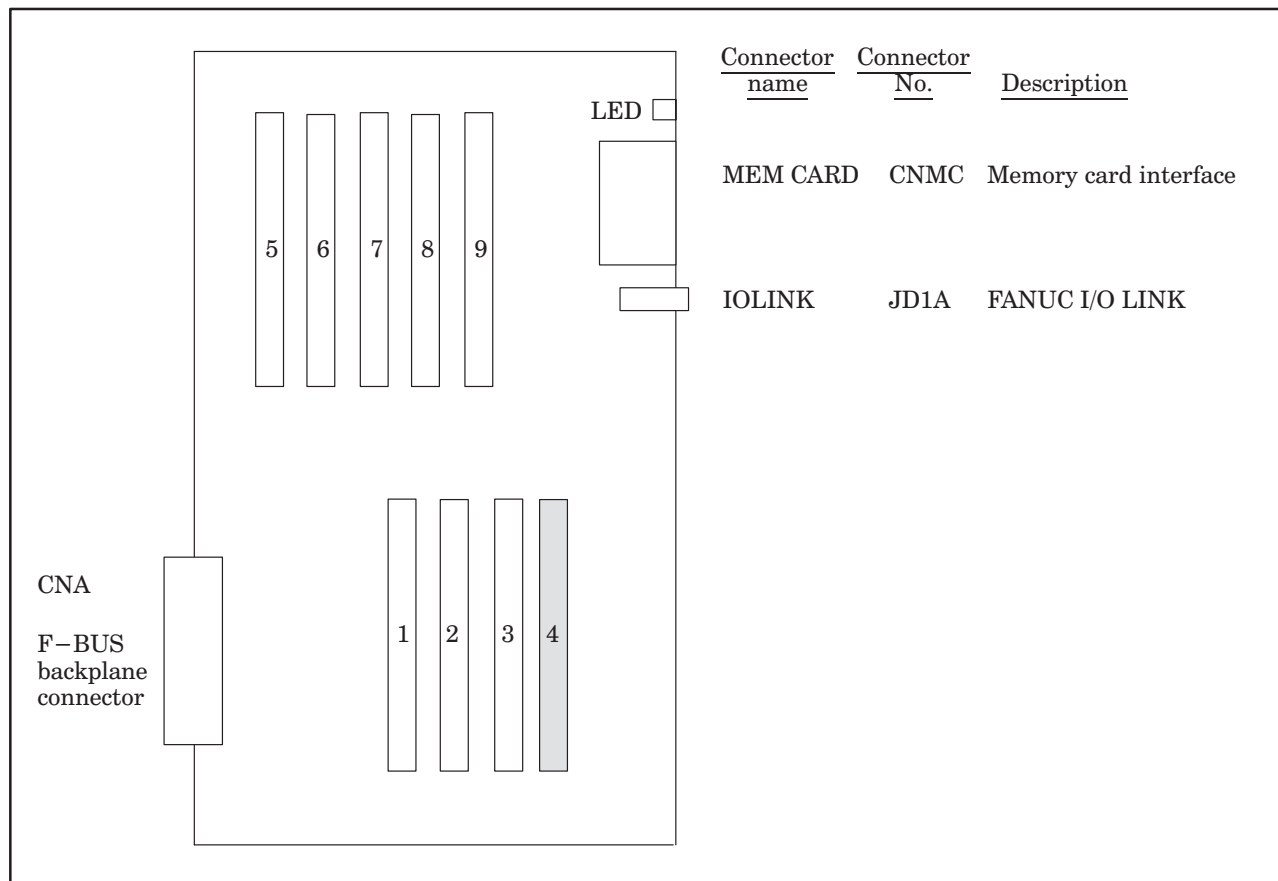

No.	Module name	Function outline
1	Conversational CPU module	CPU module for conversational function
2	DRAM module	Work RAM for conversational function
3	ROM module	System ROM for conversational function
4	SRAM module	Sub-memory for conversational function
5	ROM module	System ROM for PMC-NB
6	PMC CPU module	CPU module for PMC-NB
7	PMC engine module	PMC operation control, I/O Link control
8	SRAM module	Work RAM for PMC-NB
9	FLASH ROM module	FLASH EPROM

**NOTE** Power for battery backup is supplied to the module in the shaded box. If the module is disconnected, all data will be lost.

(2) Block diagram

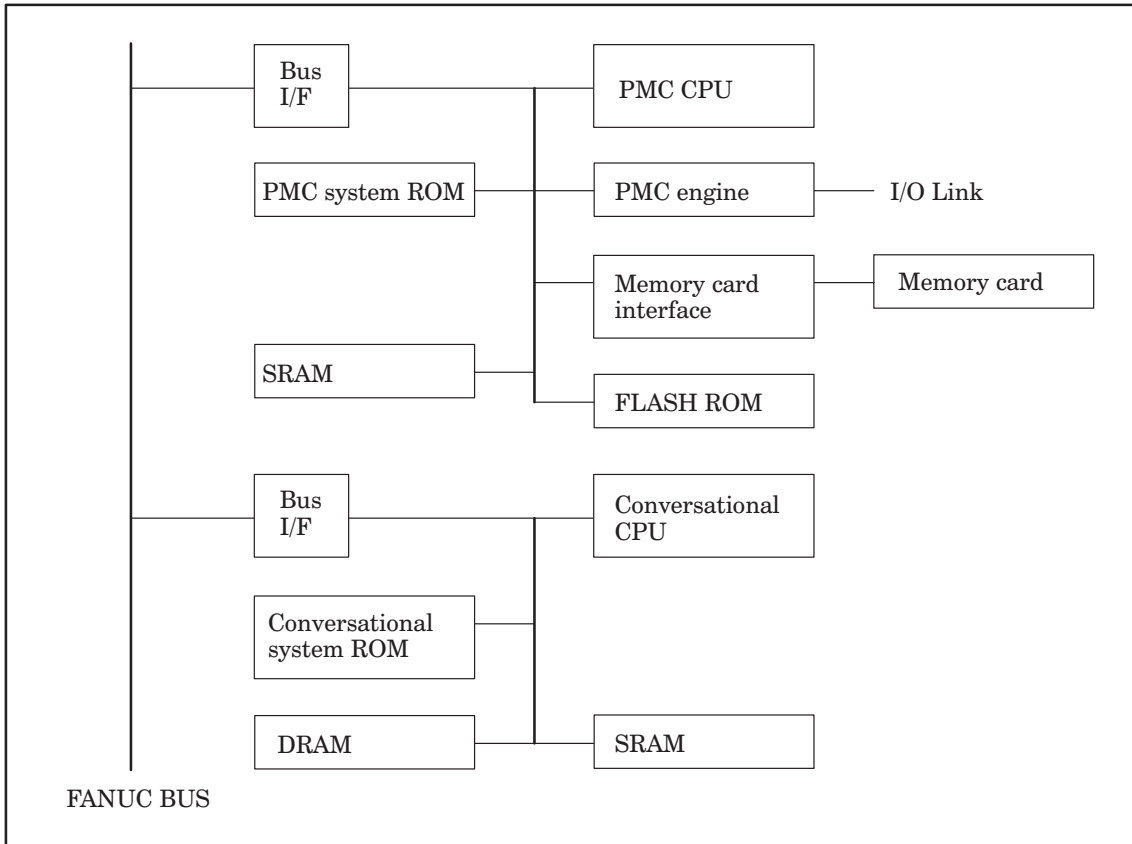

(3) Adjustment

No adjustment is needed.

(4) LED display

The STATUS LEDs at the top of the front of the PMC-NB board having the conversational function are used for independent functions, as shown on the right.

Legend

- : Not lit    ■ : Lit    ★★ : Blinking    ◆ : Irrelevant
- ★★ represents that the two LEDs blink simultaneously.
- ★☆ represents that the two LEDs blink alternately.

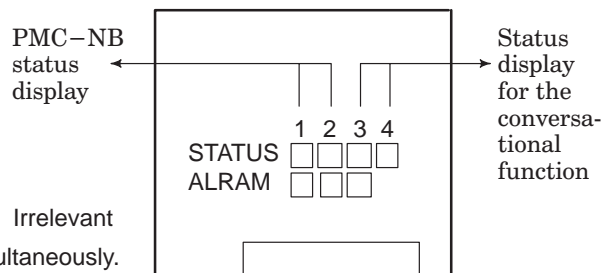

(a) LED display for the PMC-NB function

1. STATUS LED display transition when the power is turned on

No.	LED display	NC status
1	STATUS □□□□	Power-off
2	STATUS ■■◆◆	Initial state immediately after power-on or the state in which the PMC CPU is not operating
3	STATUS □■◆◆	Initial state. PMC initialization is in progress.
4	STATUS ■□◆◆	Initial state PMC ROM parity check, transfer of a Ladder or PASCAL program to DRAM in progress, SLC initialization in progress (IPL is completed in the CNC and the NC ready status is awaited.)
5	STATUS □□◆◆	Normal state

## 2. STATUS LED display for the PMC–NB function when an error occurs

No.	LED display	NC status
1	STATUS ★★◆◆	An error occurred in another PC board.
2	STATUS ■★◆◆	An error occurred during transfer to or from DI/DO. The DRAM module on the main CPU board is defective. The PMC system ROM module is defective.
3	STATUS ★■◆◆	A RAM parity error occurred in the PMC engine module (during access to the PMC).
4	STATUS □★◆◆	A RAM parity error occurred in the PMC engine module or PMC SRAM module (during access to the CPU).
5	STATUS ★☆◆◆	A failure (BUS ERR, INVALID OPCODE, etc.) occurred in the PMC function. The PMC ROM is defective.

## (b) STATUS LED display for the conversational function (TF, TTF, MF)

## 1. STATUS LED display transition when the power is turned on

No.	LED display	NC status
1	STATUS □□□□	Power-off
2	STATUS ◆◆□■	Waiting for initialization of the main CPU (waiting for ID setting)
3	STATUS ◆◆■□	Initialized state
4	STATUS ◆◆□□	Normal state

## 2. STATUS LED display for the conversational function when an error occurs (TF, TTF)

No.	LED display	NC status
1	STATUS ◆◆★★	An error occurred in another PC board.
2	STATUS ◆◆□★	A RAM parity error occurred on the PC board for the conversational function.
3	STATUS ◆◆★☆	A defective ROM module was detected on the PC board for the conversational function.
4	STATUS ◆◆■□	The CPU for the conversational function performed illegal processing.

## 3. STATUS LED display for the conversational function when an error occurs (MF)

No.	LED display	NC status
1	STATUS ◆◆★★	An error occurred in another PC board or the CPU for the conversational function.

## (c) ALARM LED display

No.	LED display	NC status
1	ALARM ■□□	The CPU for the conversational function asserts SYSFAIL.
2	ALARM □■□	The PMC CPU asserts SYSFAIL.
3	ALARM ■■□	The PMC CPU is in the stop state.
4	ALARM □□■	An error (SLC error) occurred during data transfer to or from DI/DO.
5	ALARM ■■■	A RAM (RAM on the PMC engine module or PMC SRAM module) parity error occurred in the PMC.

## 7.9 Configuration of the Axis CPU Board (ACPU)

(1) Parts layout

Drawing number : A16B-2201-0360

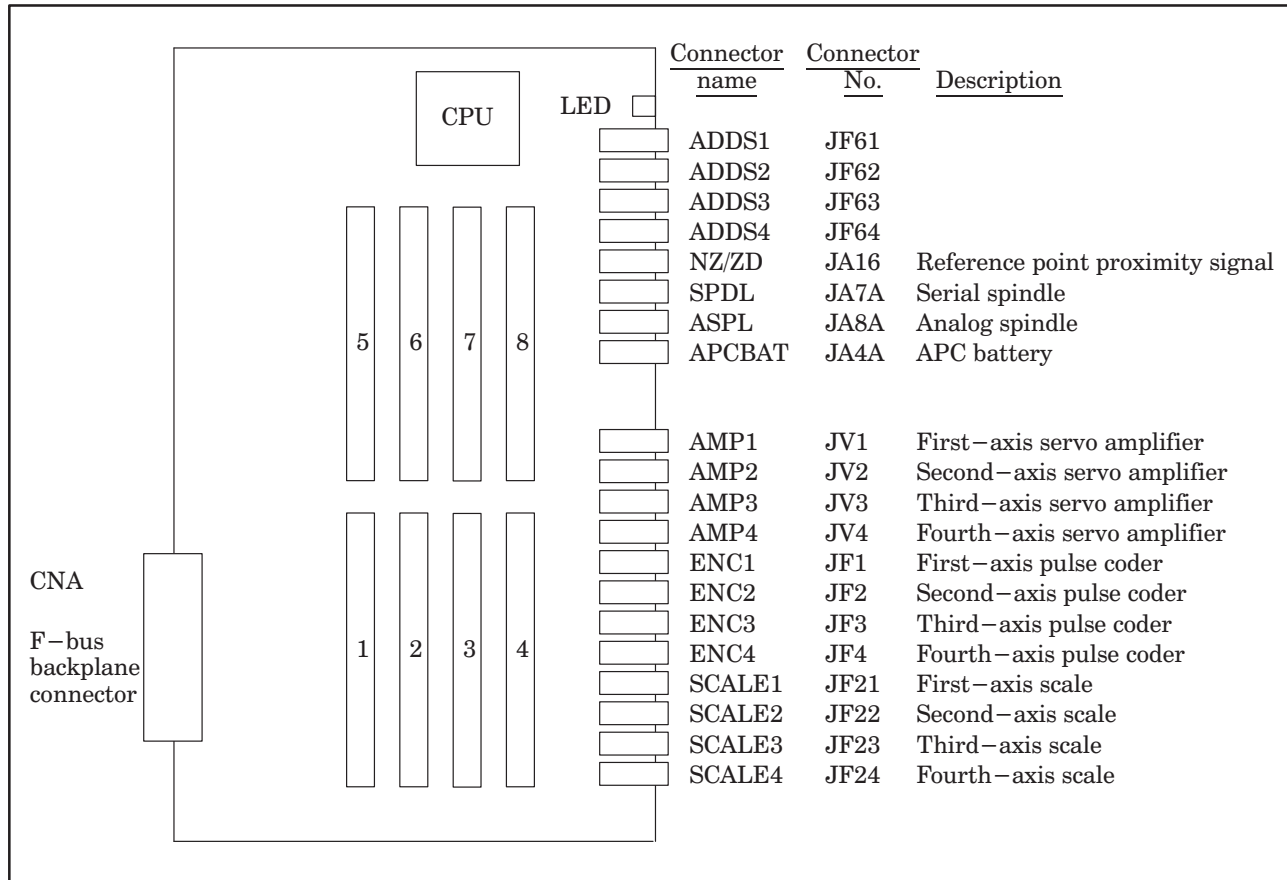

No.	Module name	Function outline
1	Servo control module	Third-axis and fourth-axis servo control
2	Servo control module	First-axis and second-axis servo control
3	Servo interface module	Third-axis and fourth-axis amplifier, pulse coder interface
4	Servo interface module	First-axis and second-axis amplifier, pulse coder interface
5	DRAM module	RAM for the axis CPU system
6	Error motion check module	First-axis and second-axis error motion check interface
7	Error motion check module	Third-axis and Fourth-axis error motion check interface
8	Spindle control module	Spindle control, reference point proximity signal interface

(2) Block diagram

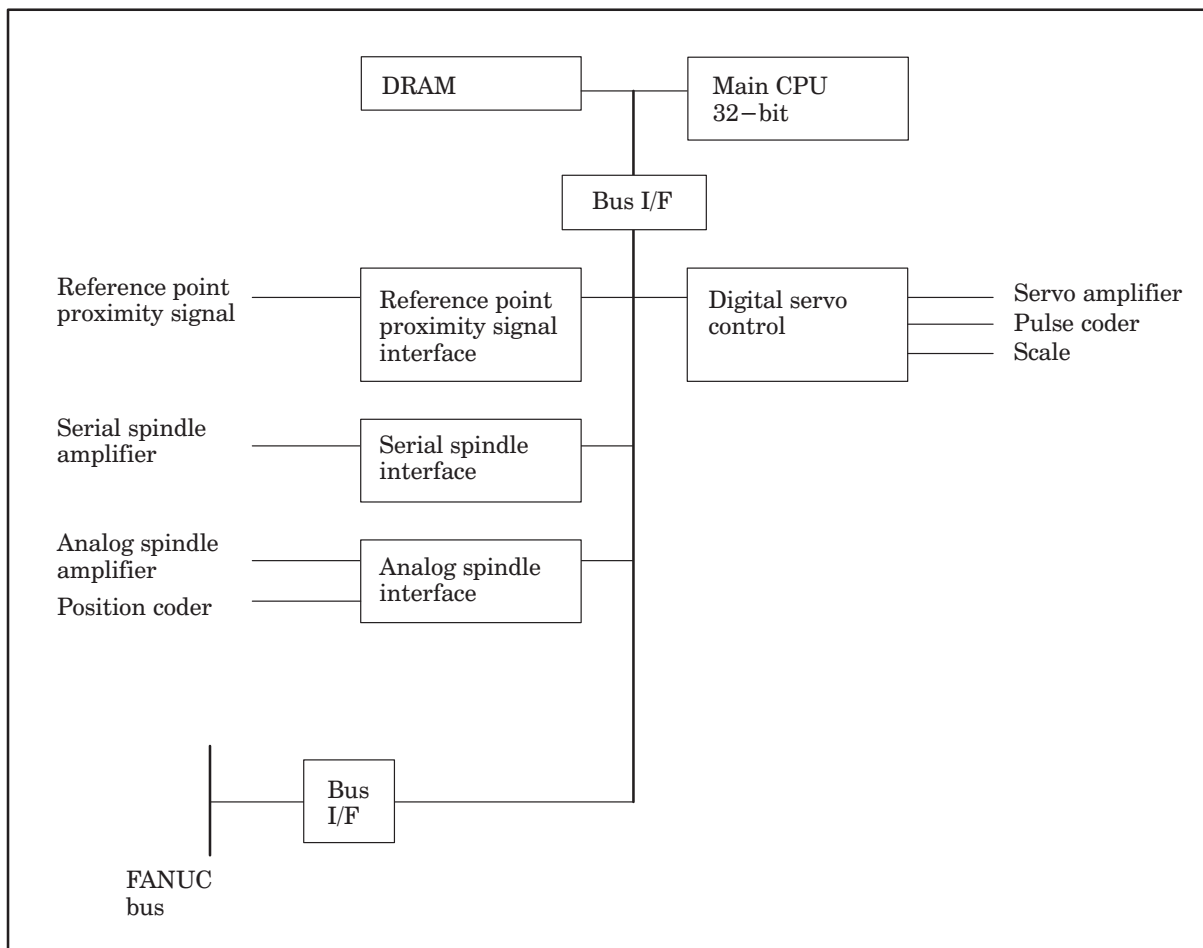

(3) Adjustment

No adjustment is needed.

## (4) LED display

□ : Not lit ■ : Lit ★ : Blinking

STATUS LEDs are green. ALARM LEDs are red.

## 1. LED display transition when the power is turned on (STATUS LED)

No.	LED display	NC status
1	STATUS □□□□	Power-off
2	STATUS ■■■■	State in which the axis CPU is not started
3	STATUS ■□□■	Beginning of the activation of the axis CPU software
4	STATUS □□□■	End of the axis CPU local RAM test
5	STATUS ■■■□	End of the axis CPU local RAM clear
6	STATUS □■■□	Waiting for a response from the main CPU (1)
7	STATUS ■□■□	Waiting for a response from the main CPU (2)
8	STATUS □□■□	Waiting for a response from the main CPU (3)
9	STATUS ■■□□	Waiting for a response from the digital servo
10	STATUS □■□□	Waiting for a response from the main CPU (4)
15	STATUS ■□□□	Normal state. The power-on sequence is ended.

## 2. LED display when an error occurs (STATUS LED)

No.	LED display	NC status
1	STATUS ★□□□	An error occurred in the DRAM of the axis CPU.
2	STATUS □★□□	An unsupported component is installed in the DRAM of the axis CPU.
3	STATUS □★★□	A logical slot setting error occurred.
4	STATUS □■■■■	A system error occurred.

## 3. LED display when an error occurs (ALARM LED)

No.	LED display	NC status
2	ALARM □■□	SYSFAIL (fault in a module on the F-BUS) occurred.
3	ALARM ■■□	A servo alarm occurred.
4	ALARM □□■	SYSEMG (NMI in a module on the F-BUS) occurred.
5	ALARM ■□■	A bus error occurred (F-BUS, servo, spindle module).
6	ALARM □■■	A parity alarm occurred in the DRAM module.

### 7.10 Configuration of the Multiaxis Buffer Board

(1) Parts layout

Drawing number : A16B-2201-0351

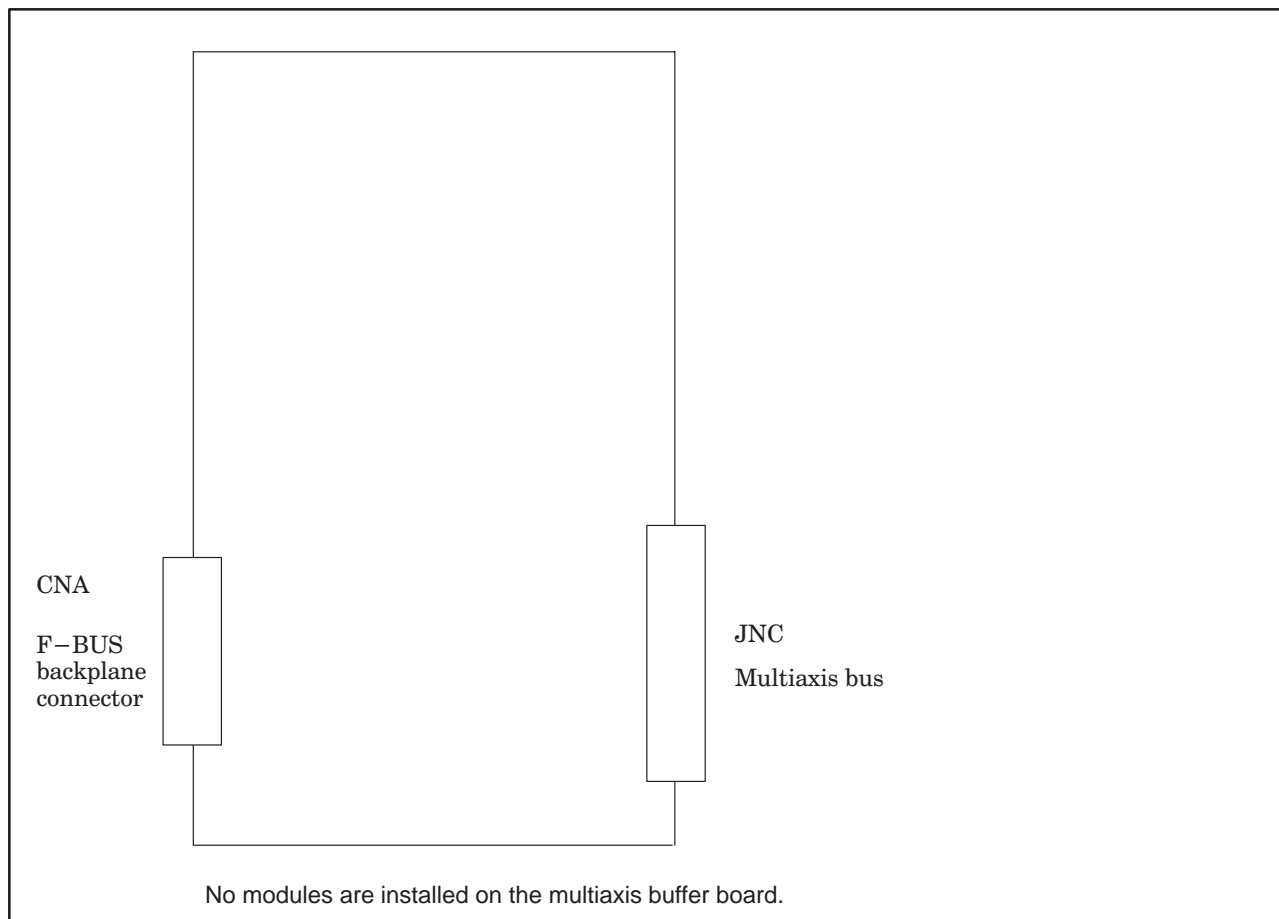

(2) Block diagram

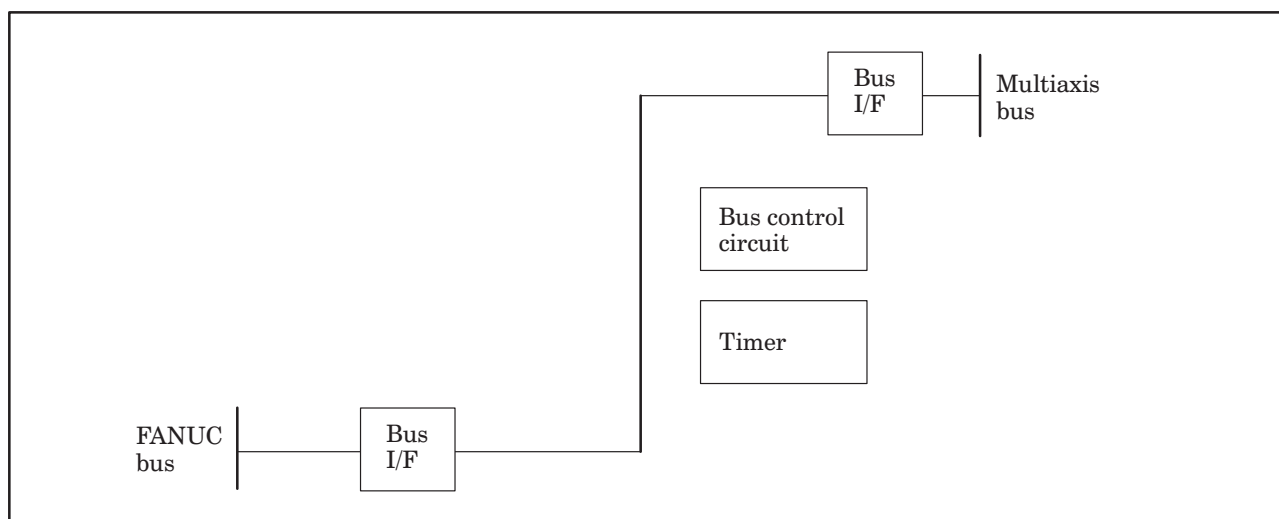

(3) Adjustment

No adjustment is needed.



## (4) LED display

□ : Not lit   ■ : Lit   ★ : Blinking

STATUS LEDs are green. ALARM LEDs are red.

1.2. The STATUS LEDs (green LEDs) on this PC board have no meaning.

3. LED display when an error occurs (ALARM LED)

No.	LED display	NC status
1	ALARM □■□	SYSFAIL occurred in the axis shelf. (A fault occurred in a module of the axis shelf.)
2	ALARM □■■	SYSEMG occurred in the axis shelf. (An NMI occurred in a module of the axis shelf.)
3	ALARM ■□■	A bus error occurred during write access from the main shelf.
4	ALARM ■■■□	A bus error occurred in the F-bus of the axis shelf.

### 7.11 Configuration of the RISC Board

(1) Parts layout

Drawing number : A16B-2201-0710/02A and on

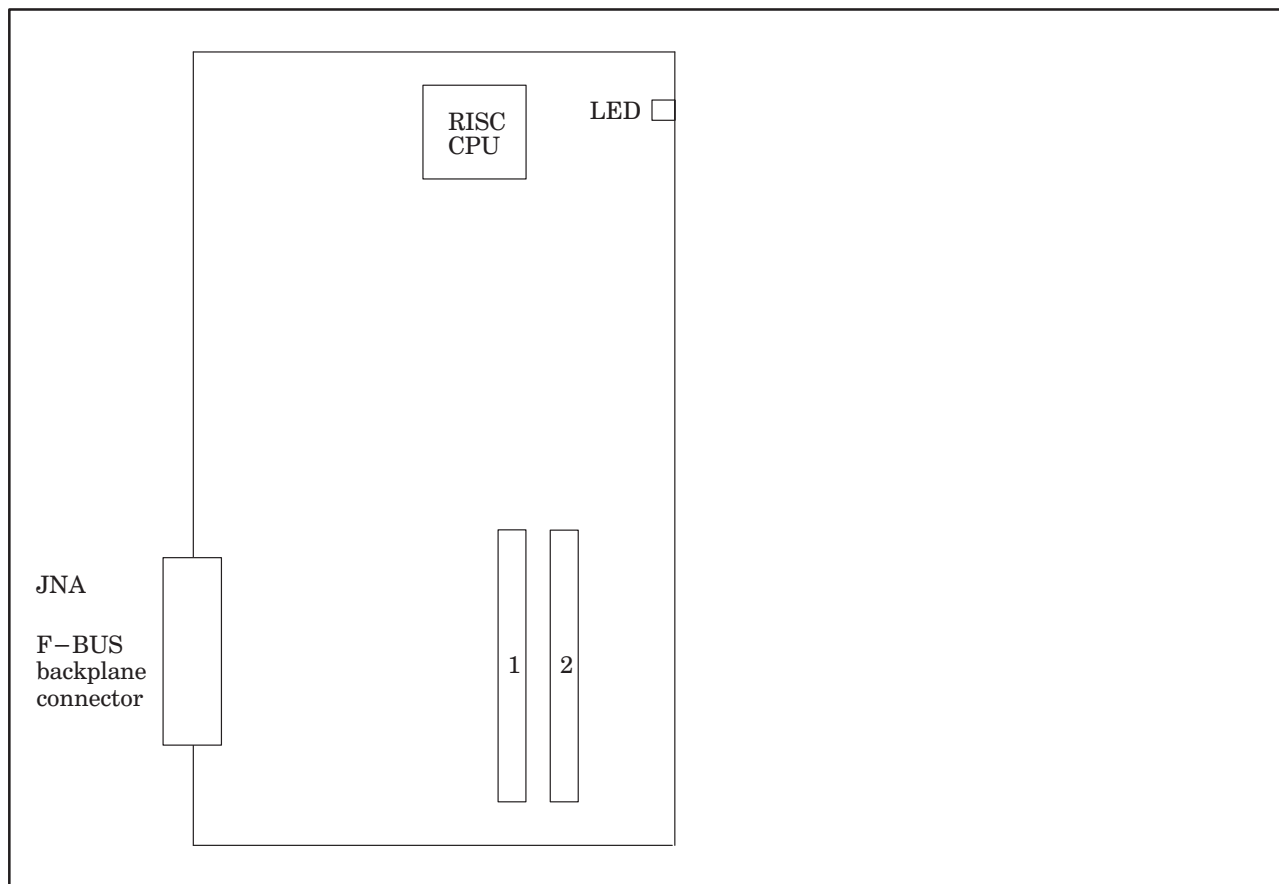

No.	Module name	Function outline
1	SRAM module	For SHARED RAM
2	ROM module	Memory for RISC CPU

(2) Block diagram

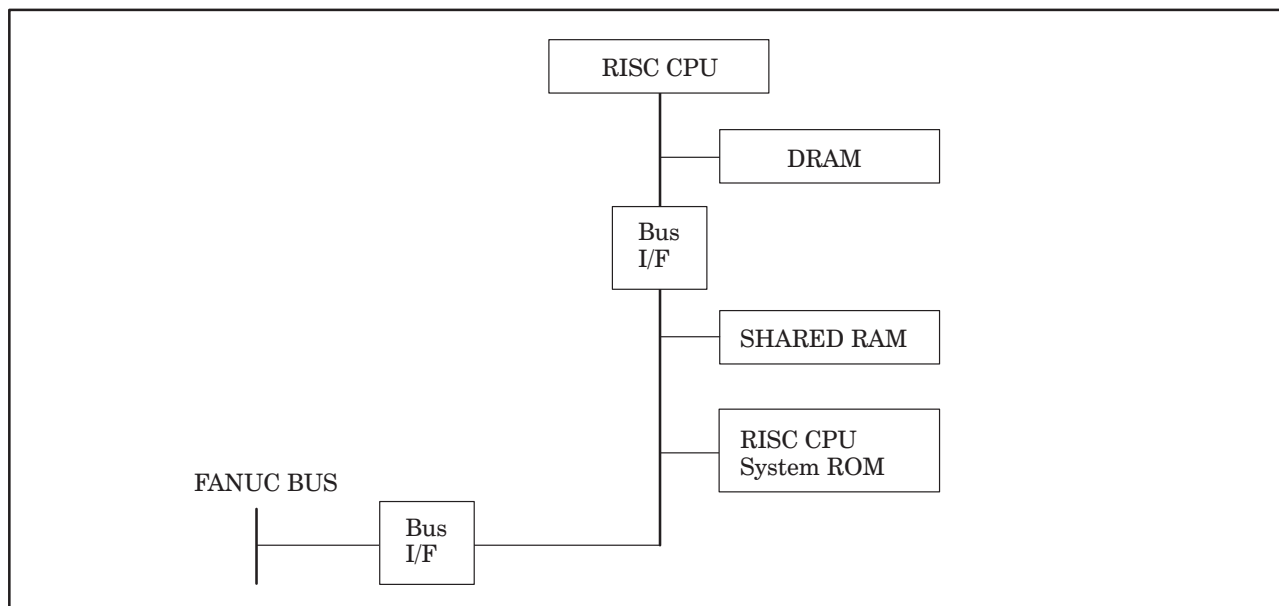

## (3) Adjustment

No adjustment is needed.

## (4) LED display

□ : Not lit ■ : Lit ★ : Blinking

STATUS LEDs are green. ALARM LEDs are red.

1. LED display when the power is turned on (Nos.1 to 8) and during operation (Nos. 9 to 12)  
(STATUS LED)

No.	LED display	NC status
1	STATUS □□□□	Power-off
2	STATUS ■■■■	Immediately after power-on or the state in which the RISC CPU is not started
3	STATUS □□□■	DRAM or SHARED RAM test in progress (If an error is detected during the test, this LED display is held and not changed.)
4	STATUS □□■□	ROM test in progress (If an error is detected during the test, this LED display is held and not changed.)
5	STATUS ■□□□	Waiting for the processing by the CNC (1)
6	STATUS ■□□■	Waiting for the processing by the CNC (2)
7	STATUS ■□■□	Waiting for the processing by the CNC (3)
8	STATUS ■■□□	Waiting for the processing by the CNC (4)
9	STATUS □□□★	Waiting for RISC mode
10	STATUS □★□★	Waiting for the input of an NC statement
11	STATUS □★★□	Executing a command in RISC mode
12	STATUS ★□□□	Resetting

2. LED display when an error occurs (STATUS LED)

No.	LED display	NC status
1	STATUS □□□■	An error occurred during test of the DRAM or SRAM module (shared RAM) on the RISC board.
2	STATUS □□■□	An error occurred during test of the ROM module.
3	STATUS □□■■	A synchronization signal cannot be detected from the main CPU.
4	STATUS □■□□	An error occurred during access to the F-bus. (The module ID cannot be read correctly.)
5	STATUS ■■■□	A system error occurred.

3. LED display when an error occurs (ALARM LED)

No.	LED display	NC status
1	ALARM ■□□	The RISC CPU is not started.
2	ALARM □■□	A parity alarm occurred in the SRAM module.
3	ALARM □□■	A parity alarm occurred in the DRAM on the RISC board.

### 7.12 Configuration of the Sub. CPU board (SUB-A)

(1) Parts layout

Drawing number : A16B-2201-0310

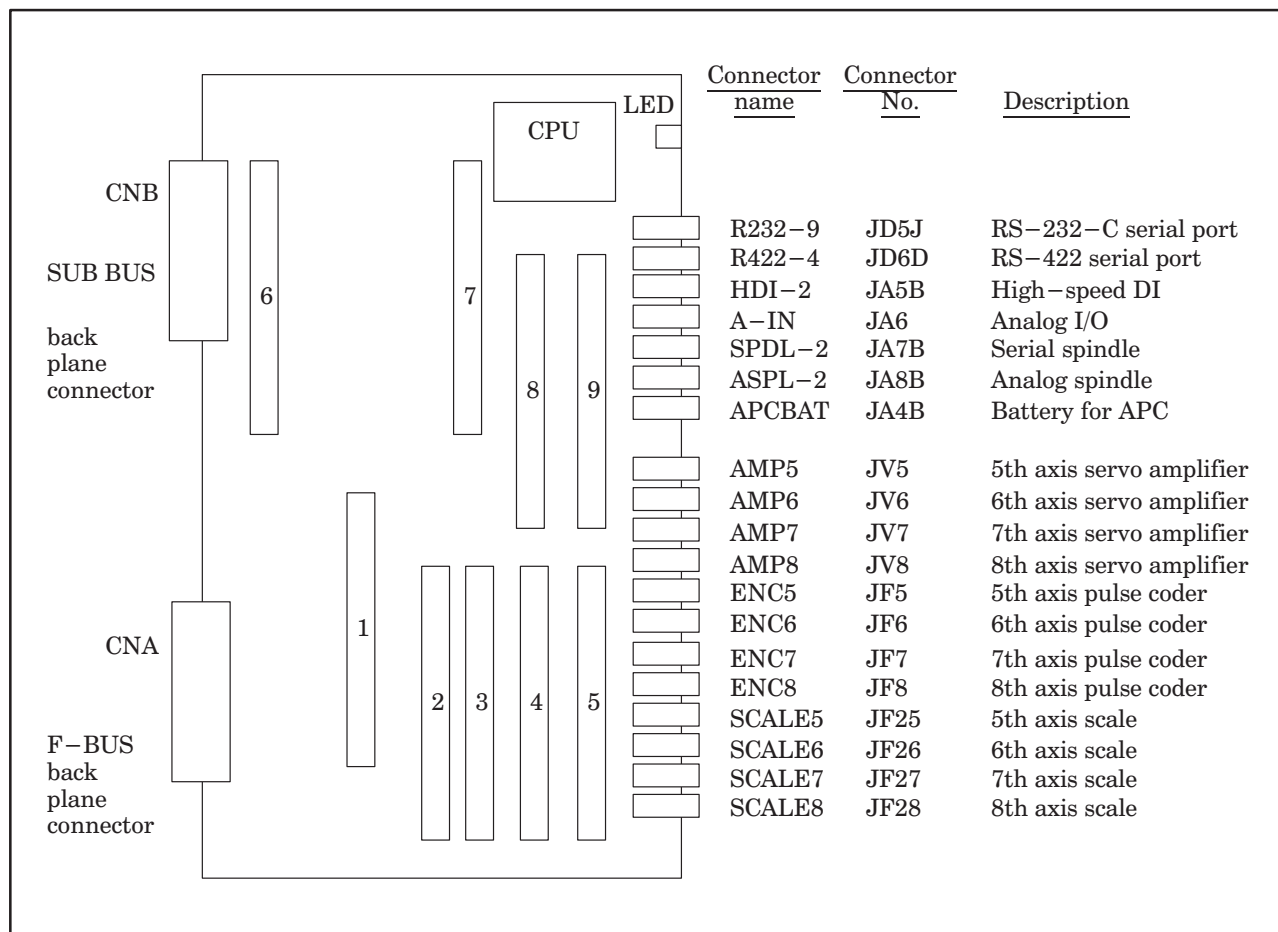

No.	Module name	Function outline
1	SRAM module	For SHARED RAM
2	Servo control module	7th and 8th servo control
3	Servo control module	5th and 6th servo control
4	Servo interface module	7th and 8th amplifier, pulse coder interface
5	Servo interface module	5th and 6th amplifier, pulse coder interface
6	High-speed SRAM module	High-speed RAM for sub.system
7	DRAM module	RAM for sub.system
8	2nd spindle control module	2nd spindle control, HDI interface etc....
9	Analog I/O & Serial communication module	Input/Output of analog, RS-232C, RS-422 interface

## (2) Block diagram

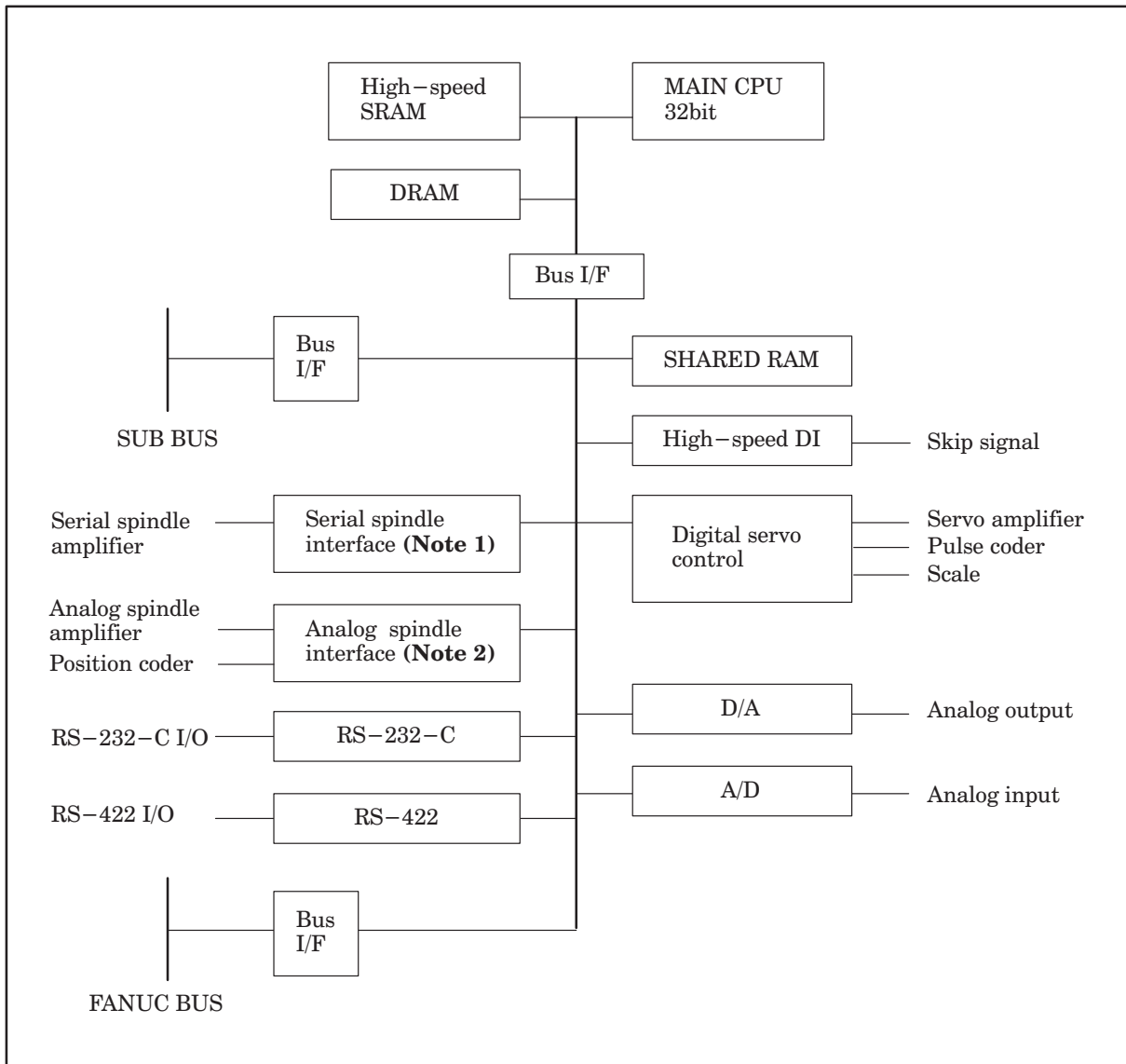

**NOTE 1** When the module of analog spindle is built in as a module of spindle control, the serial spindle interface is not there.

**NOTE 2** When a serial spindle module is mounted as the spindle control module, an analog spindle interface is not used.

## (3) Adjustment

No adjustment is needed.

## (4) LED display

□ : Not lit   ■ : Lit   ★ : Blinking

STATUS LEDs are green. ALARM LEDs are red.

## 1. LED display transition when the power is turned on (STATUS LED)

No.	LED display	NC status
1	STATUS □□□□	Power-off
2	STATUS ■■■■	Initial state immediately after power-on
3	STATUS ■□□■	State in which the sub-CPU software is to be activated
4	STATUS □□□■	Beginning of the activation of the sub-CPU software
5	STATUS ■■■□	Beginning of the sub-CPU local RAM test
6	STATUS □■■□	End of the sub-CPU local RAM test
7	STATUS ■□■□	End of initialization of a custom LSI chip
8	STATUS □□■□	Beginning of the internal processing of the sub-CPU
9	STATUS ■■□□	Waiting for the processing by the main CPU (1)
10	STATUS □■□■	Waiting for the processing by the main CPU (2)
11	STATUS ■□□□	Normal state. The power-on sequence has ended.

## 2. LED display when an error occurs (STATUS LED)

No.	LED display	NC status
1	STATUS ★□★★	An error occurred in the local RAM of the sub-CPU.
2	STATUS □■■■	A system error occurred.

## 3. LED display when an error occurs (ALARM LED)

No.	LED display	NC status
1	ALARM ■□□	The sub-CPU is not started.
2	ALARM □■□	SYSFAIL (fault in a module on the F-bus) occurred.
3	ALARM ■■□	A servo alarm occurred.
4	ALARM □□■	SYSEMG (NMI in a module on the F-bus) occurred.
5	ALARM ■□■	An ABC alarm (parity alarm in shared RAM, fault in the peripheral bus, SUB bus, FANUC bus) occurred.
6	ALARM □■■	A parity alarm occurred in the DRAM module.
7	ALARM ■■■	A parity alarm occurred in the high-speed SRAM module.

### 7.13 Configuration of the Standard Multiaxis Sub-CPU Board (MAX SUB-B)

(1) Parts layout

Drawing number : A16B-2201-0331

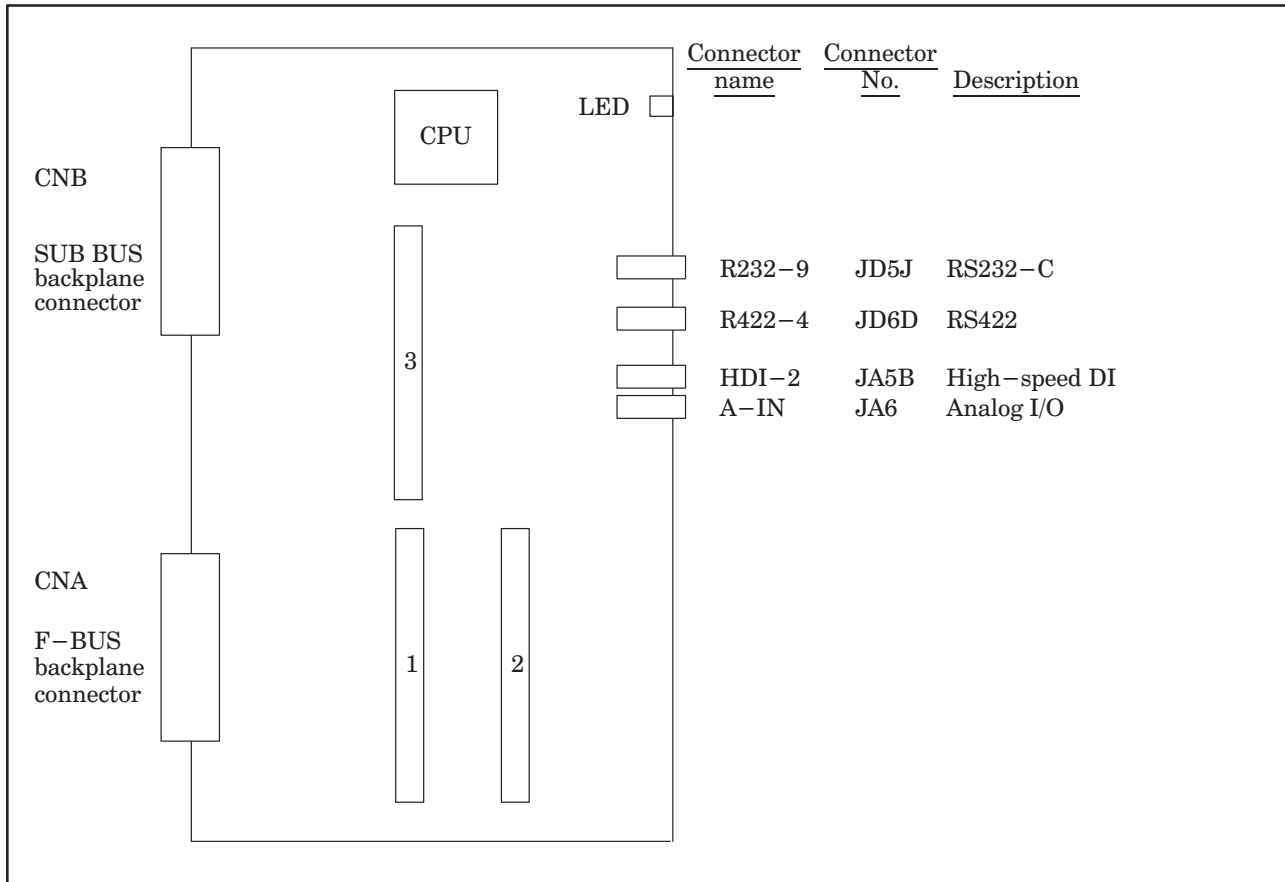

No.	Module name	Function outline
1	SRAM module	For SHARED RAM
2	Analog I/O and serial communication module	Analog input/output, RS-232C and RS-422 interface
3	DRAM module	RAM for subsystem

(2) Block diagram

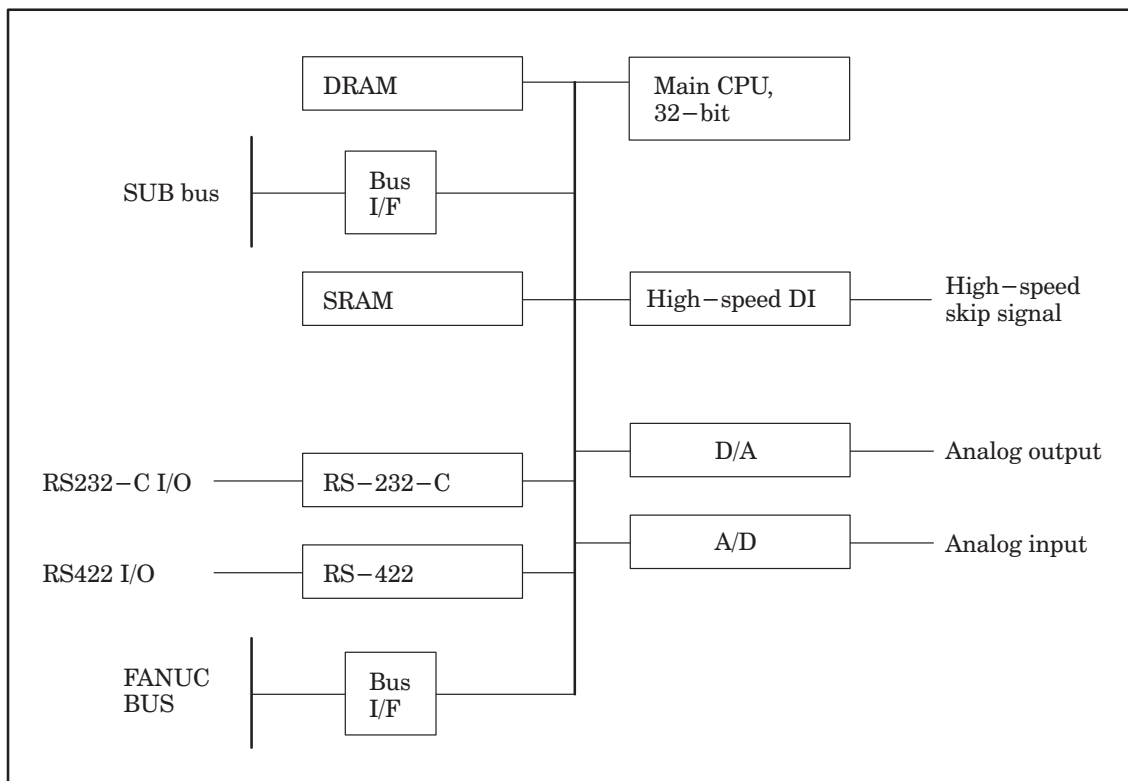

(3) Adjustment

No adjustment is needed.

(4) LED display

□ : Not lit    ■ : Lit    ★ : Blinking

STATUS LEDs are green. ALARM LEDs are red.

1. LED display transition when the power is turned on (STATUS LED)

No.	LED display	NC status
1	STATUS □□□□	Power-off
2	STATUS ■■■■	Initial state immediately after power-on
3	STATUS ■□□■	State in which the sub-CPU software is to be activated
4	STATUS □□□■	Beginning of the activation of the sub-CPU software
5	STATUS ■■■□	Beginning of the sub-CPU local RAM test
6	STATUS □■■□	End of the sub-CPU local RAM test
7	STATUS ■□□□	End of initialization of a custom LSI chip
8	STATUS □□■□	Beginning of sub-CPU's internal processing
9	STATUS ■■□□	Waiting for the processing by the main CPU (1)
10	STATUS □■□■	Waiting for the processing by the main CPU (2)
11	STATUS ■□□□	Normal state. The power-on sequence is ended



## 2. LED display when an error occurs (STATUS LED)

No.	LED display	NC status
1	STATUS ★□★★	An error occurred in the local RAM of the sub-CPU.
2	STATUS □■■■■	A system error occurred.

## 3. LED display when an error occurs (ALARM LED)

No.	LED display	NC status
1	ALARM □■□	SYSFAIL (fault in a module on the F-bus) occurred.
2	ALARM ■■□	A servo alarm occurred.
3	ALARM □□■	SYSEMG (NMI in a module on the F-bus) occurred.
4	ALARM ■□■	An ABC alarm (parity alarm in the shared RAM, fault in the peripheral bus, SUB bus, FANUC bus) occurred.
5	ALARM □■■	A parity alarm occurred in the DRAM module.

### 7.14 Configuration of the Upgraded Sub-CPU Board (SUB-C)

(1) Parts layout

Drawing number : A16B-2202-0571

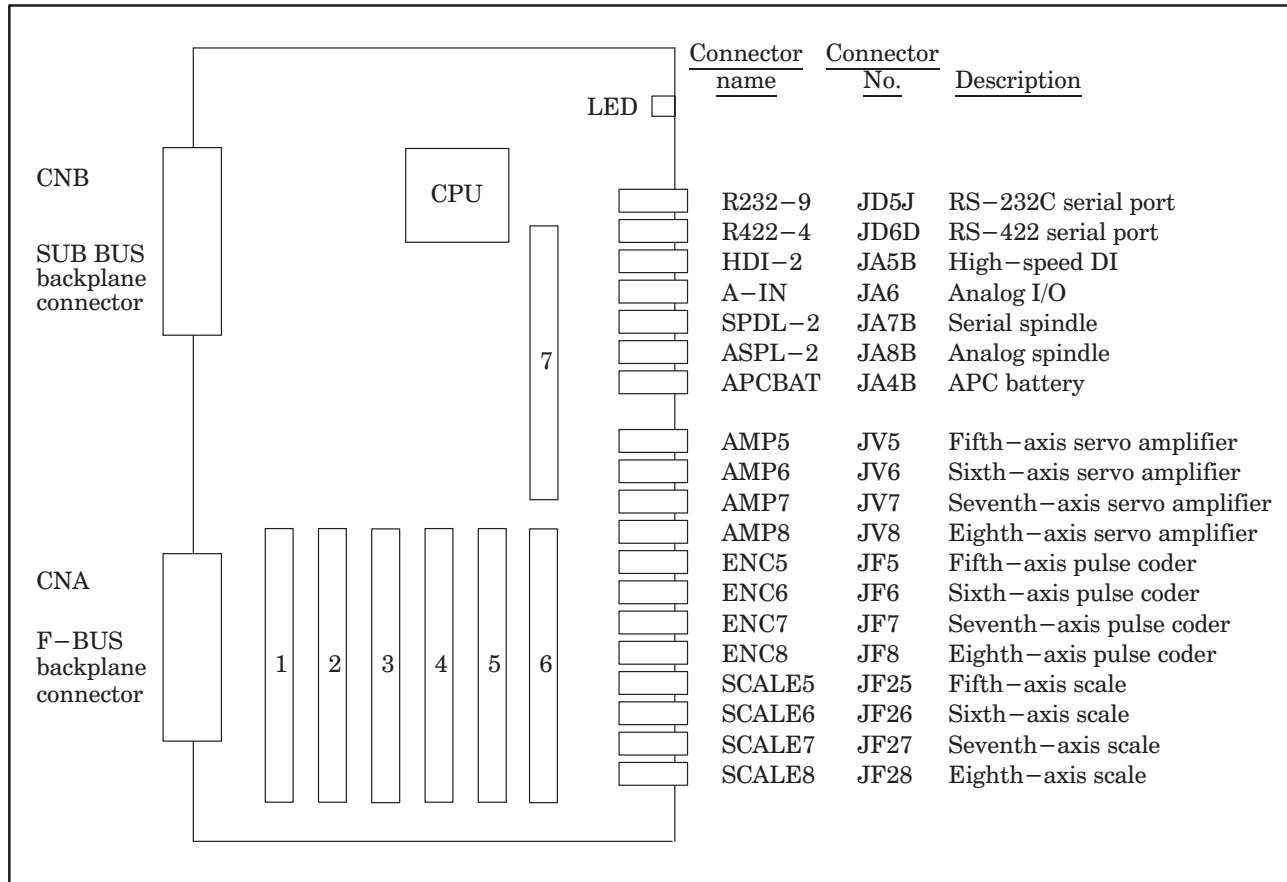

No.	Module name	Function outline
1	Analog I/O & serial communication module	Analog input/output, RS-232C and RS-422 interface
2	Second spindle control module	Second spindle control, HDI interface, etc.
3	Servo control module	Seventh-axis and eighth-axis servo control
4	Servo control module	Fifth-axis and sixth-axis servo control
5	Servo interface module	Seventh-axis and eighth-axis servo amplifier, pulse coder interface
6	Servo interface module	Fifth-axis and sixth-axis servo amplifier, pulse coder interface
7	DRAM module	RAM for subsystem

## (2) Block diagram

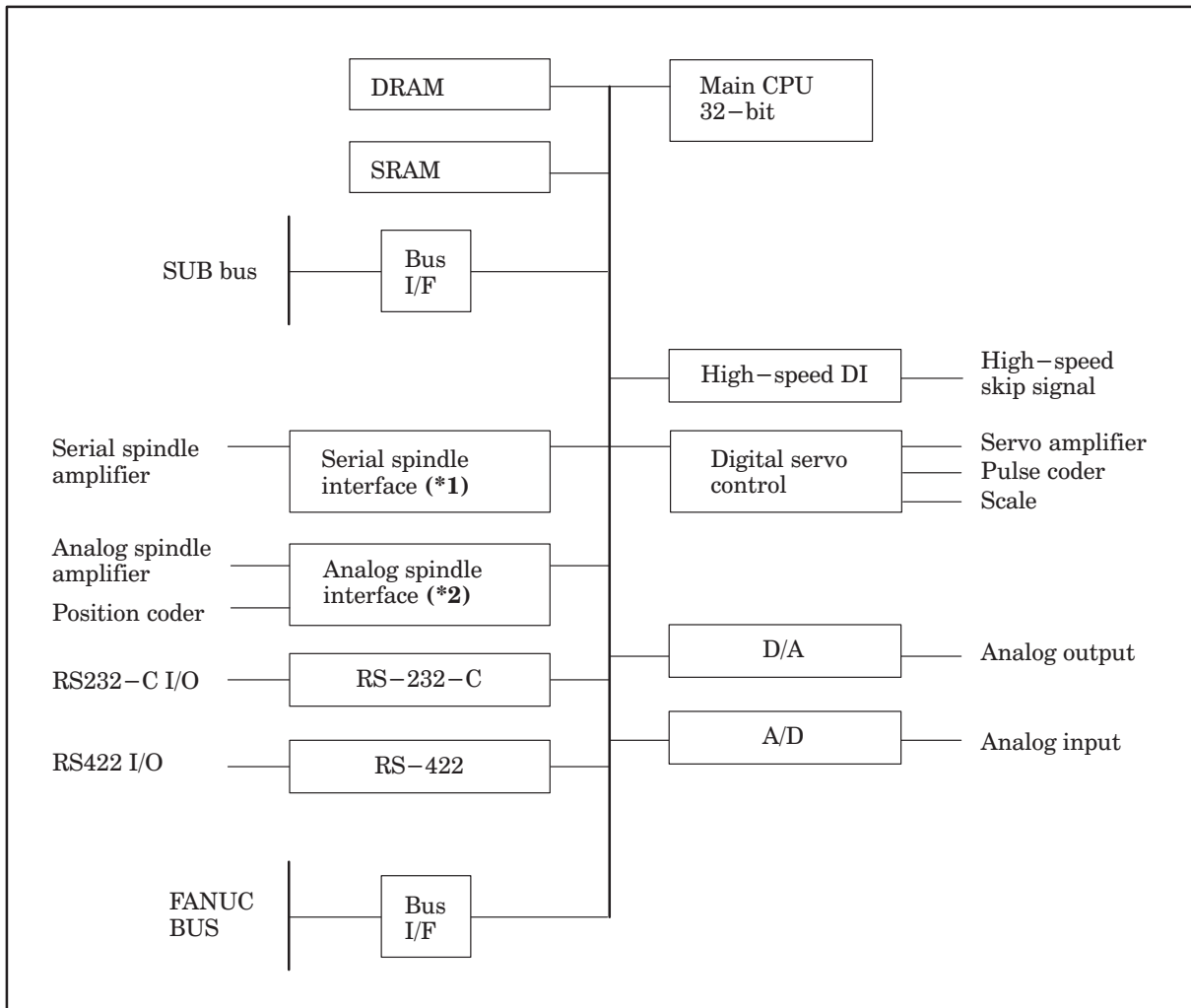

**NOTE 1** If the analog spindle module is mounted as the spindle control module, the serial spindle interface is not included.

**NOTE 2** If the serial spindle module is mounted as the spindle control module, the analog spindle interface is not included.

## (3) Adjustment

No adjustment is needed.

## (4) LED display

□ : Not lit ■ : Lit ★ : Blinking

STATUS LEDs are green. ALARM LEDs are red.

## 1. LED display transition when the power is turned on (STATUS LED)

No.	LED display	NC status
1	STATUS □□□□	Power-off
2	STATUS ■■■■	Initial state immediately after power-on
3	STATUS ■□□■	State in which the sub-CPU software is to be activated
4	STATUS □□□■	Beginning of the activation of the sub-CPU software
5	STATUS ■■■□	Beginning of the sub-CPU local RAM test
6	STATUS □■■□	End of the sub-CPU local RAM test
7	STATUS ■□■□	End of initialization of a custom LSI chip
8	STATUS □□■□	Beginning of the sub-CPU's internal processing
9	STATUS ■■□□	Waiting for the processing by the main CPU (1)
10	STATUS □■□■	Waiting for the processing by the main CPU (2)
11	STATUS ■□□□	Normal state. The power-on sequence has ended.

## 2. LED display when an error occurs (STATUS LED)

No.	LED display	NC status
1	STATUS ★□★★	An error occurred in the local RAM of the sub-CPU.
2	STATUS □■■■	A system error occurred.

## 3. LED display when an error occurs (ALARM LED)

No.	LED display	NC status
1	ALARM ■□□	The sub-CPU has not started.
2	ALARM □■□	SYSFAIL (fault in a module on the F-bus) occurred.
3	ALARM ■■□	A servo alarm occurred.
4	ALARM □□■	SYSEMG (NMI in a module on the F-bus) occurred.
5	ALARM ■□■	An ABC alarm (fault in the peripheral bus, FANUC bus) occurred.
6	ALARM □■■	A parity alarm occurred in the DRAM module.
7	ALARM ■■■	A parity alarm occurred in the SRAM mounted on the sub-CPU.

## 7.15 Configuration of additional axis (ADAX) board

(1) Parts layout

Drawing number : A16B-2201-0311

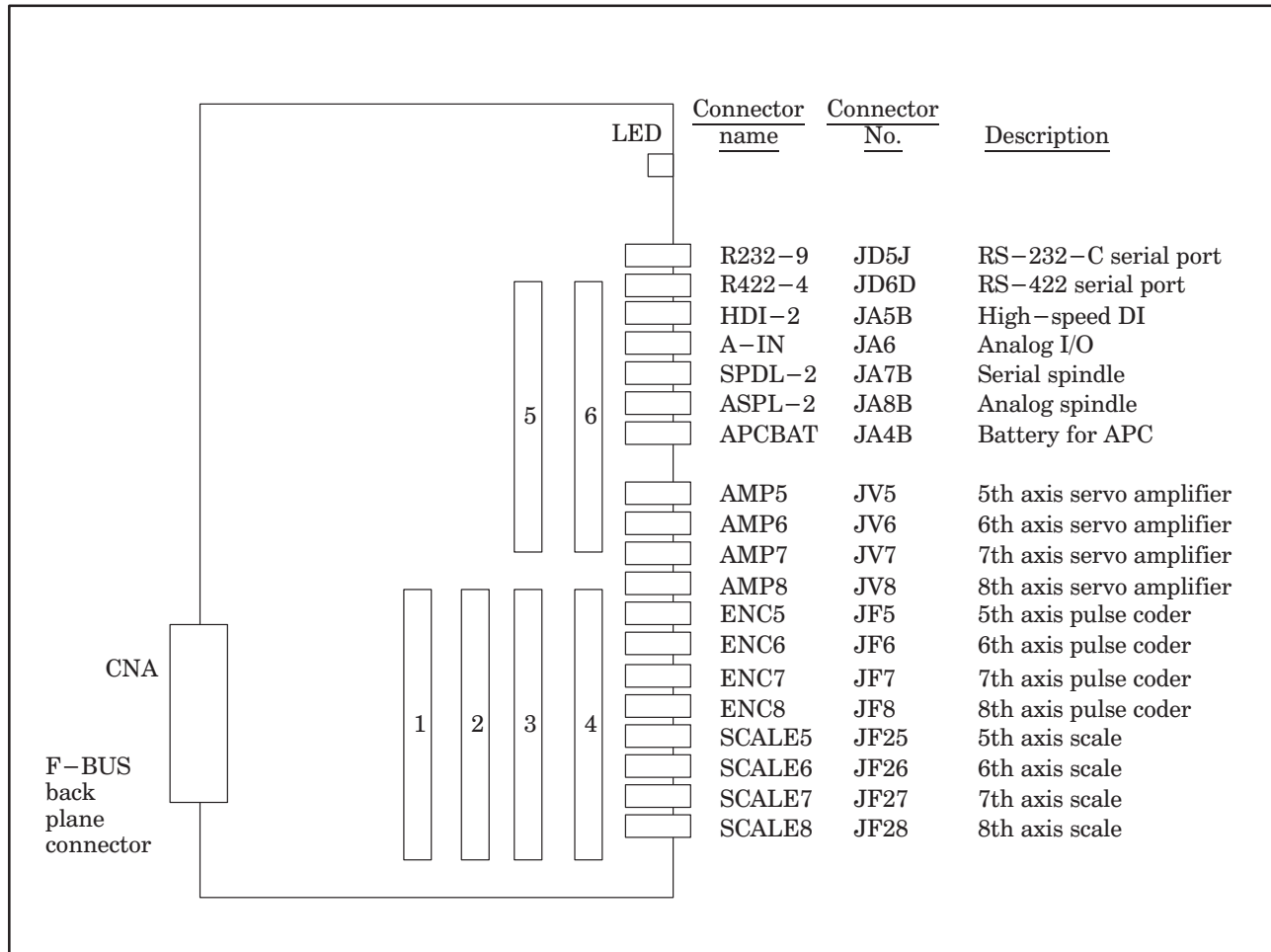

No.	Module name	Function outline
1	Servo control module	7th and 8th servo control
2	Servo control module	5th and 6th servo control
3	Servo interface module	7th and 8th amplifier, pulse coder interface
4	Servo interface module	5th and 6th amplifier, pulse coder interface
5	2nd spindle control module	2nd spindle control, HDI interface etc....
6	Analog I/O & serial communications module	Input/Output of Analog, RS-232C, RS-422 interface

(2) Block diagram

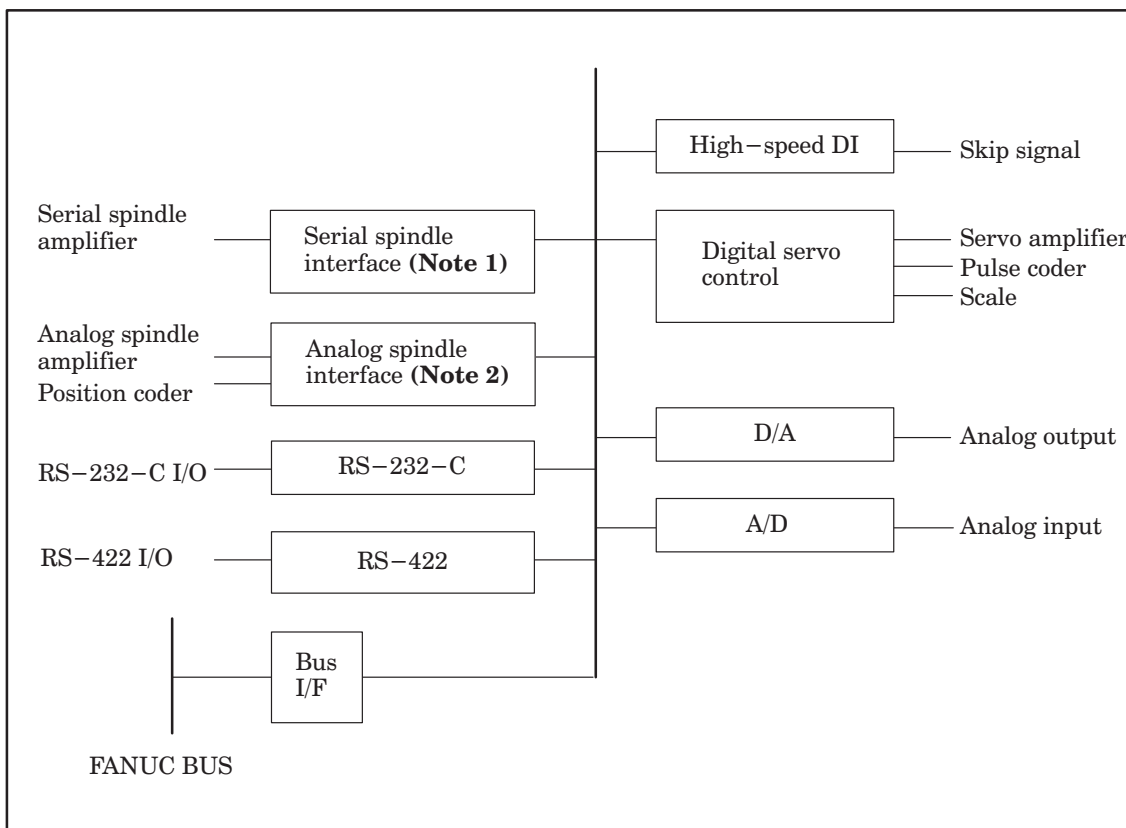

**NOTE 1** When the module of analog spindle is built in as a module of spindle control, the serial spindle interface is not there.

**NOTE 2** When a serial spindle module is mounted as the spindle control module, an analog spindle interface is not used.

(3) Adjustment

No adjustment is needed.

(4) LED display

□ : Off    ■ : Lit    ★ : Flashing

The STATUS LEDs are green and the ALARM LEDs are red.

LED display when an error occurs (ALARM LED)

No.	LED display	NC status
1	ALARM ■□□	Not used
2	ALARM □■□	SYSFAIL (A fault occurred on some modules of F-BUS.)
3	ALARM ■■□	SERVO ALARM
4	ALARM □□■	SYSEMG (NMI occurred on some modules of F-BUS.)
5	ALARM ■□■	ABC ALARM (PARITY ALARM on SHARED RAM, A fault of peripheral bus)
6	ALARM □■■	Not used
7	ALARM ■■■	Not used

**NOTE** All the STATUS LED is always off

## 7.16 Configuration of the option 1 board

### (1) Parts layout

- Drawing number : A16B-2200-0910 (Remote buffer communication function+Graphic function)  
 : A16B-2200-0911 (DNC1 communication function+Graphic function RAM added)  
 : A16B-2200-0912 (Graphic function)  
 : A16B-2200-0913 (Remote buffer communication function)  
 : A16B-2200-0914 (DNC1 communication function)  
 : A16B-2200-0915 (Remote buffer communication function+Graphic function RAM added)  
 : A16B-2200-0916 (DNC1 communication function+\*Graphic function RAM added)  
 : A16B-2200-0917 (Graphic function RAM added)  
 : A16B-2200-0918 (Remote buffer communication function+\*Graphic function RAM added)  
 : A16B-2200-0919 (\*Graphic function RAM added)

\* : For MMC-IV or 9.5"LCD

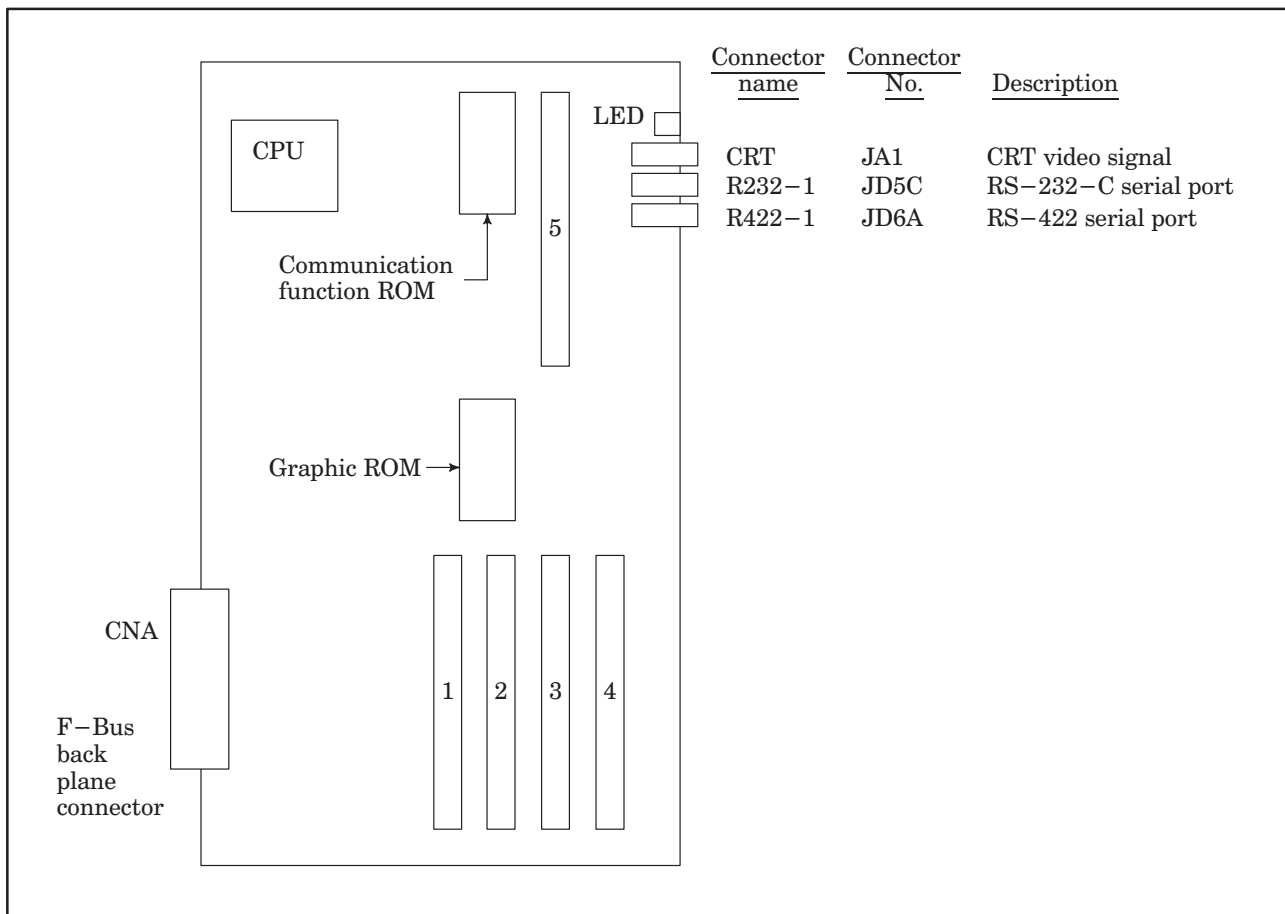

No.	Module name	Function outline
1	Graphic CPU module	Graphic display control CPU
2	Graphic engine module	Graphic display control circuit (No.2) Add in case of CAP II of FS15-TT.
3	Graphic engine module	Graphic display control circuit (No.1)
4	CRT control module	Character display control circuit for 9" CRT Character display control circuit for 10" LCD Character display control circuit for 14" CRT
5	Communication control module	Serial communication control, DMA control

(2) Block diagram

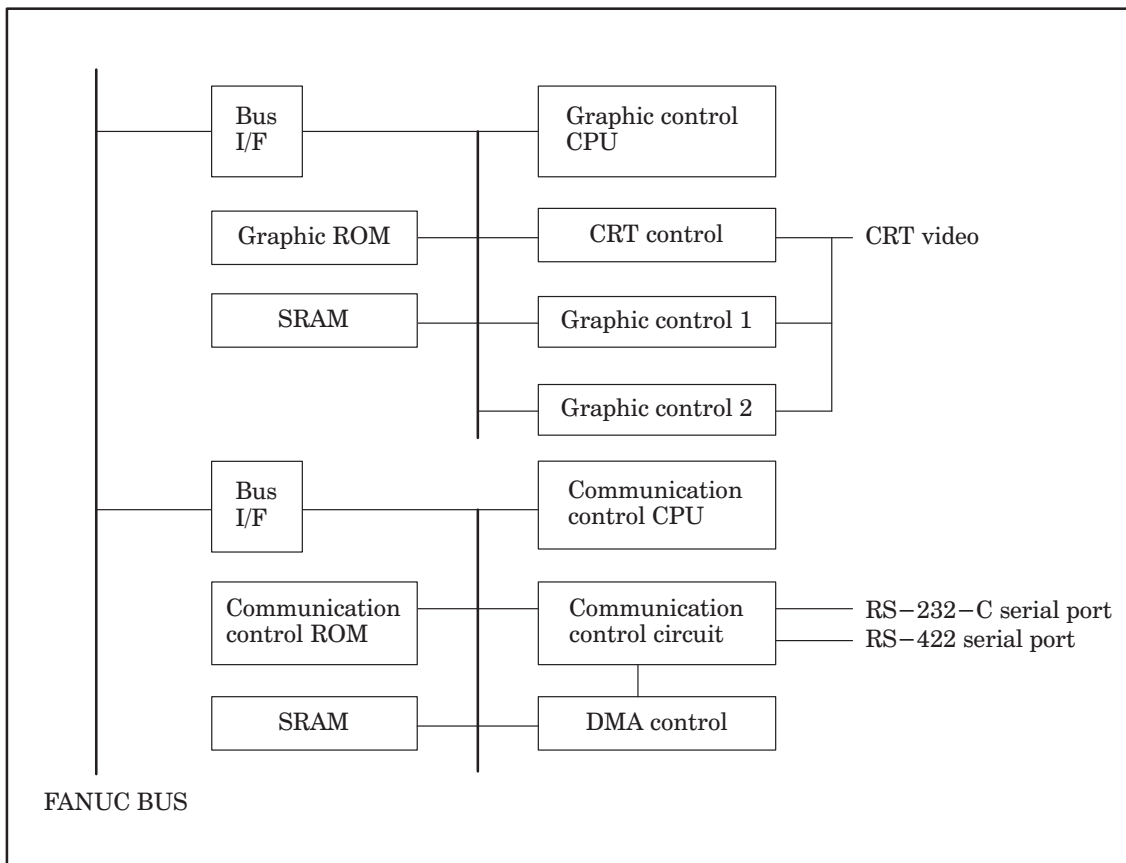

(3) Adjustment

No adjustment is needed.

(4) LED display

The STATUS LEDs in the front upper section of the option board are used for two independent functions as shown in the figure on the right.

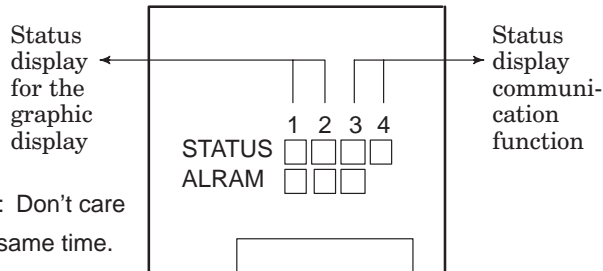

□ : Off    ■ : Lit    ★★ : Flashing    ◆ : Don't care

★★ means both of LED are flashing at the same time.

★ means both of LED are flashing alternately.

(a) LED display of graphic display function

1. LED display transition when the power is turned on

No.	LED display	NC status
1	STATUS ■■■■ ALARM ■□□	Startup status immediately after the power is turned on.
2	STATUS □■◆◆ ALARM □□□	Waiting for setting each processor of ID in the system.
3	STATUS ■□◆◆ ALARM □□□	Waiting for initialization of each processor in the system.
4	STATUS □□◆◆ ALARM □□□	The initialization of graphic display function is completed and on executing.



## 2. LED display when an error occurs

No.	LED display	NC status
1	STATUS <input type="checkbox"/> <input type="checkbox"/> <input checked="" type="checkbox"/> <input checked="" type="checkbox"/> <input checked="" type="checkbox"/> <input checked="" type="checkbox"/> ALARM <input checked="" type="checkbox"/> <input type="checkbox"/> <input type="checkbox"/>	ROM parity error occurs. Change graphic ROM.
2	STATUS <input checked="" type="checkbox"/> <input type="checkbox"/> <input checked="" type="checkbox"/> <input checked="" type="checkbox"/> ALARM <input checked="" type="checkbox"/> <input type="checkbox"/> <input type="checkbox"/>	RAM parity error occurs. Change option 1 board.
3	STATUS <input type="checkbox"/> <input checked="" type="checkbox"/> <input checked="" type="checkbox"/> <input checked="" type="checkbox"/> ALARM <input checked="" type="checkbox"/> <input type="checkbox"/> <input type="checkbox"/>	Command error occurs. Change option 1 board.
4	STATUS <input checked="" type="checkbox"/> <input checked="" type="checkbox"/> <input checked="" type="checkbox"/> <input checked="" type="checkbox"/> ALARM <input checked="" type="checkbox"/> <input type="checkbox"/> <input type="checkbox"/>	NMI from other boards. Check LED display of other boards.
5	STATUS <input checked="" type="checkbox"/> <input type="checkbox"/> <input checked="" type="checkbox"/> <input checked="" type="checkbox"/> ALARM <input checked="" type="checkbox"/> <input type="checkbox"/> <input type="checkbox"/>	Bus error (Wrong memory access) occurs. Change option 1 board.
6	STATUS <input checked="" type="checkbox"/> <input checked="" type="checkbox"/> <input checked="" type="checkbox"/> <input checked="" type="checkbox"/> ALARM <input checked="" type="checkbox"/> <input type="checkbox"/> <input type="checkbox"/>	Division error occurs. Change option 1 board.
7	STATUS <input checked="" type="checkbox"/> <input checked="" type="checkbox"/> <input checked="" type="checkbox"/> <input checked="" type="checkbox"/> ALARM <input checked="" type="checkbox"/> <input type="checkbox"/> <input type="checkbox"/>	Incorrect interruption occurs. Change option 1 board.

## (b) Communication function (Display of remote buffer)

## 1. LED display transition when the power is turned on

No.	LED display	NC status
1	STATUS <input checked="" type="checkbox"/> <input checked="" type="checkbox"/> <input checked="" type="checkbox"/> <input checked="" type="checkbox"/> ALARM <input checked="" type="checkbox"/> <input type="checkbox"/> <input type="checkbox"/>	Startup status immediately after power is turned on or remote buffer CPU is not executing.
2	STATUS <input checked="" type="checkbox"/> <input checked="" type="checkbox"/> <input type="checkbox"/> <input type="checkbox"/> ALARM <input checked="" type="checkbox"/> <input type="checkbox"/> <input type="checkbox"/>	Initialization of remote buffer is beginning.
3	STATUS <input checked="" type="checkbox"/> <input checked="" type="checkbox"/> <input checked="" type="checkbox"/> <input type="checkbox"/> ALARM <input checked="" type="checkbox"/> <input type="checkbox"/> <input type="checkbox"/>	Initialization of remote buffer is completed and status of waiting for command from CNC.
4	STATUS <input checked="" type="checkbox"/> <input checked="" type="checkbox"/> <input type="checkbox"/> <input checked="" type="checkbox"/> ALARM <input checked="" type="checkbox"/> <input type="checkbox"/> <input type="checkbox"/>	Command is executed.
5	STATUS <input checked="" type="checkbox"/> <input checked="" type="checkbox"/> <input checked="" type="checkbox"/> <input checked="" type="checkbox"/> ALARM <input checked="" type="checkbox"/> <input type="checkbox"/> <input type="checkbox"/>	On closing (After closing, back to the status of No.3.)

## 2. LED display when an error occurs

No.	LED display	NC status
1	STATUS <input checked="" type="checkbox"/> <input checked="" type="checkbox"/> <input checked="" type="checkbox"/> <input type="checkbox"/> ALARM <input checked="" type="checkbox"/> <input type="checkbox"/> <input type="checkbox"/>	ROM parity alarm occurred.
2	STATUS <input checked="" type="checkbox"/> <input checked="" type="checkbox"/> <input type="checkbox"/> <input checked="" type="checkbox"/> ALARM <input checked="" type="checkbox"/> <input type="checkbox"/> <input type="checkbox"/>	RAM error of test
3	STATUS <input checked="" type="checkbox"/> <input checked="" type="checkbox"/> <input checked="" type="checkbox"/> <input checked="" type="checkbox"/> ALARM <input checked="" type="checkbox"/> <input type="checkbox"/> <input type="checkbox"/>	A fault occurred in the remote buffer. (BUS ERROR, illegal interruption etc....)
4	STATUS <input checked="" type="checkbox"/> <input checked="" type="checkbox"/> <input checked="" type="checkbox"/> <input checked="" type="checkbox"/> ALARM <input checked="" type="checkbox"/> <input type="checkbox"/> <input type="checkbox"/>	NMI from other boards
5	STATUS <input checked="" type="checkbox"/> <input checked="" type="checkbox"/> <input checked="" type="checkbox"/> <input checked="" type="checkbox"/> ALARM <input checked="" type="checkbox"/> <input type="checkbox"/> <input checked="" type="checkbox"/>	Parity alarm occurred on the work RAM of remote buffer.

- ALARM LED (red LED) display when an error occurs

The FANUC Series 15-B has many monitoring circuits that constantly check whether the processor itself is operating normally and whether the signals are being normally transferred between processors. If an error occurs, the CNC can stop the operation because of these circuits. On the other hand, an error on a PC board may result in the activation of a monitoring circuit on the main board or sub-board. If this occurs, the ALARM LED (red LED) on the main board or sub-board may light, even though no error has occurred on the PC board.

The tables below list the ALARM LED statuses when an error occurs on the main board or on a sub-board:

ALARM LED display when an error occurs (when the main CPU is MAIN-A or MAIN-B)

Main board	Sub-board	Description
<input type="checkbox"/> <input type="checkbox"/> <input checked="" type="checkbox"/> SYSEMG.	<input type="checkbox"/> <input type="checkbox"/> <input checked="" type="checkbox"/> SYSEMG.	An NMI error occurred on the PMC, remote buffer, or a PC board other than the main board or sub-board on the F-bus. The power supply unit supplies a lower-than-normal voltage.
<input checked="" type="checkbox"/> <input checked="" type="checkbox"/> <input type="checkbox"/> SERVO ALARM	<input type="checkbox"/> <input checked="" type="checkbox"/> <input type="checkbox"/> SYSFAIL	An error occurred in the servo module on the main board. The software detected an error on a PC board on the F-bus.
<input type="checkbox"/> <input type="checkbox"/> <input checked="" type="checkbox"/> SYSEMG.	<input checked="" type="checkbox"/> <input checked="" type="checkbox"/> <input type="checkbox"/> SERVO ALARM	An error occurred in the servo module of the sub-board.

ALARM LED display when an error occurs (when the main CPU is MAIN-C)

Main board	Sub-board	Description
<input type="checkbox"/> <input checked="" type="checkbox"/> <input type="checkbox"/> SYSFAIL	<input type="checkbox"/> <input checked="" type="checkbox"/> <input type="checkbox"/> SYSFAIL	The software detected an error on a PC board on the F-bus.
<input type="checkbox"/> <input type="checkbox"/> <input checked="" type="checkbox"/> SYSEMG.	<input type="checkbox"/> <input type="checkbox"/> <input checked="" type="checkbox"/> SYSEMG.	An NMI error occurred on the PMC, remote buffer, or a PC board other than main board or sub-board on the F-bus. The power supply unit supplies a lower-than-normal voltage.
<input checked="" type="checkbox"/> <input checked="" type="checkbox"/> <input type="checkbox"/> SERVO ALARM	<input type="checkbox"/> <input checked="" type="checkbox"/> <input type="checkbox"/> SYSFAIL	An error occurred in the servo module on the main board.
<input type="checkbox"/> <input checked="" type="checkbox"/> <input type="checkbox"/> SYSFAIL or <input type="checkbox"/> <input type="checkbox"/> <input checked="" type="checkbox"/> SYSEMG.	<input checked="" type="checkbox"/> <input checked="" type="checkbox"/> <input type="checkbox"/> SERVO ALARM	An error occurred in the servo module on the sub-board.

## 8. HOW TO REPLACE FUSES, PRINTED CIRCUIT BOARDS, AND OTHER UNITS

### 8.1 How to Replace the Fuses in the Power Supply Unit

- (1) Check whether any of the fuses located the front panel of the power supply unit have blown. Each fuse has a small window in which a white marker appears when the fuse has blown.
- (2) If any of the fuses has blown, correct the condition which caused the fuse to blow.
- (3) Remove the blown fuses and insert the new fuses.
- (4) If the green PIL LED does not come on even though power is being supplied to AC connector CP1 of the power supply unit, fuse F5 in the power unit may have blown. As described in section 8.2, take out the power unit and replace fuse F5. (Make sure to turn off the AC power source before the replacement.)

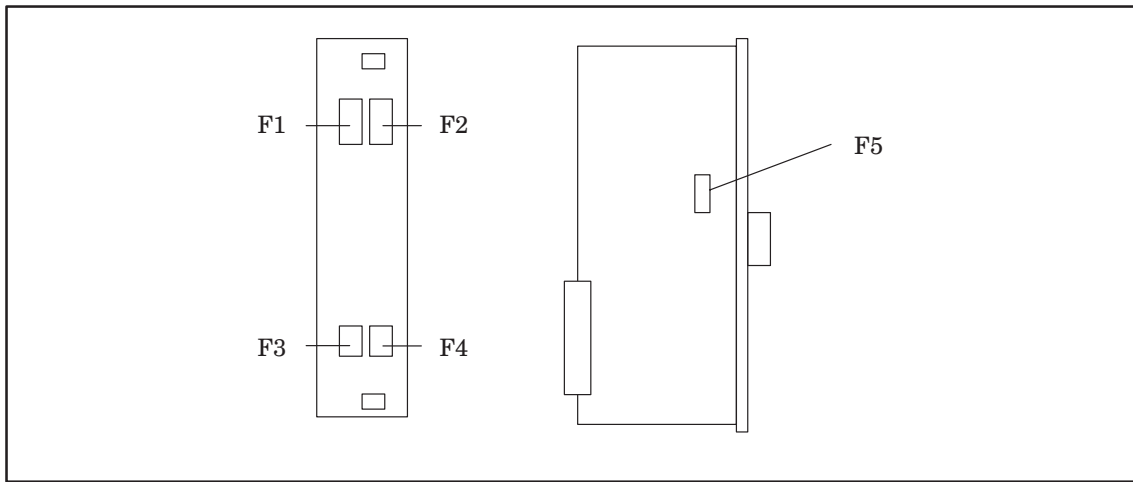

Fig. 8.1 Location of Fuses in the Power Supply Unit

Table 8.1 Table of Fuses

Unit name	Part No.	Capacity	Specification	Description	
Power supply unit	AI	F1, F2	7.5A	A60L-0001-0245#GP75	For 200 VAC power supply
		F3	3.2A	A60L-0001-0075#3.2	+24 V for use with a 9" monochrome CRT, the main CPU board, and optional printed circuit board
		F4	5A	A60L-0001-0046#5.0	For protection of the +24 E line in the machine tool from outside faults
		F5	0.3A	A60L-0001-0290#LM03	For the power supply unit
	BI	F1, F2	10A	A60L-0001-0245#GP100	For 200 VAC power supply
		F3	5A	A60L-0001-0075#5.0	+24 V for use with a 9" monochrome CRT, the main CPU board, and optional printed circuit board
		F4	5A	A60L-0001-0046#5.0	For protection of the +24 E line in the machine tool from outside faults
		F5	0.3A	A60L-0001-0290#LM03	For the power supply unit

## 8.2 How to Replace the Power Supply Unit

- (1) Make sure that the incoming AC power to the power supply unit is turned off.
- (2) Disconnect all cables connected to the power supply unit. Pinch the connectors to release the latches and withdraw the connectors.
- (3) Push down the top hand grip and push up the bottom hand grip on the front panel of the power supply unit. This releases the hand grip latches from the control unit rack. Now, remove the power supply unit from the control unit rack.
- (4) Insert the new power supply unit into the rightmost slot in the control unit rack. Push the power supply in gently until the latches lock.
- (5) Reconnect the cables to their original positions.

**NOTE** The power supply unit contains a battery for CNC memory backup. If the power supply unit is disconnected for longer than the specified period, the contents of CNC memory will be lost.

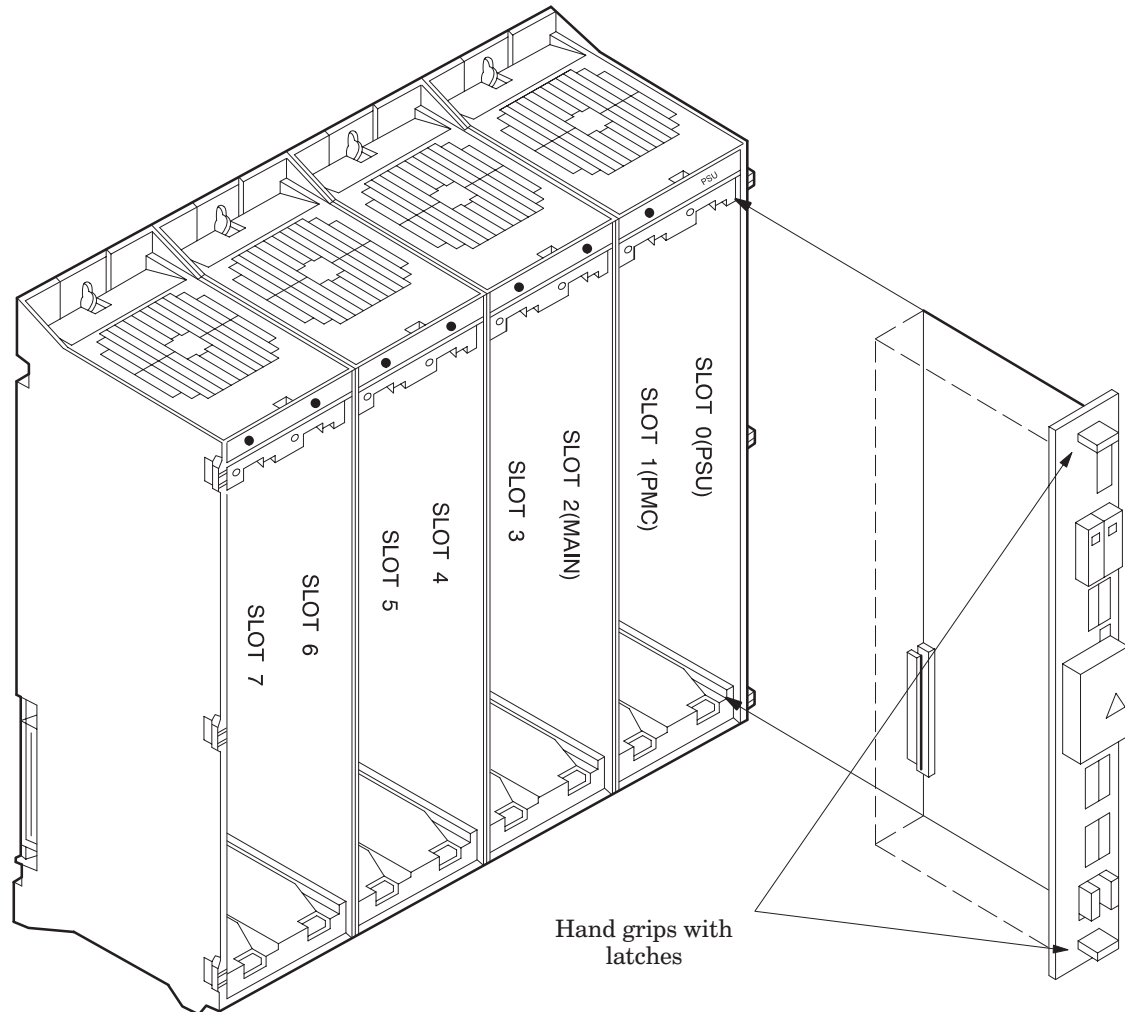

Fig. 8.2 Diagram of the Power Supply Unit

### 8.3 How to Replace the Printed Circuit Boards in the Control Unit

- (1) Make sure that the power supply unit is turned off.
- (2) Disconnect all cables connected to the printed circuit board in the control unit. Pinch the 20-pin half-pitch connector to release the latch. Withdraw the connector.
- (3) Push down the top hand grip and push up the bottom hand grip on the front panel of the printed circuit board. This releases the handgrip latches from the control unit rack. Now, remove the printed circuit board from the control unit.
- (4) Insert the new printed circuit board into the slot of the control unit rack. Push the printed circuit board in gently until the latches lock.
- (5) Reconnect the cables to their original positions.

**NOTE** To disconnect a PC board with memory which is backed up for replacement or other purposes (see Chapter 7), briefly turn the power on, then off again, immediately before disconnecting the board, and replace the PC board quickly. If the PC board is left disconnected for too long, the contents of CNC memory will be lost. If the PC board is disconnected without first turning the power on and off, the contents of CNC memory may be lost as soon as the board is disconnected.

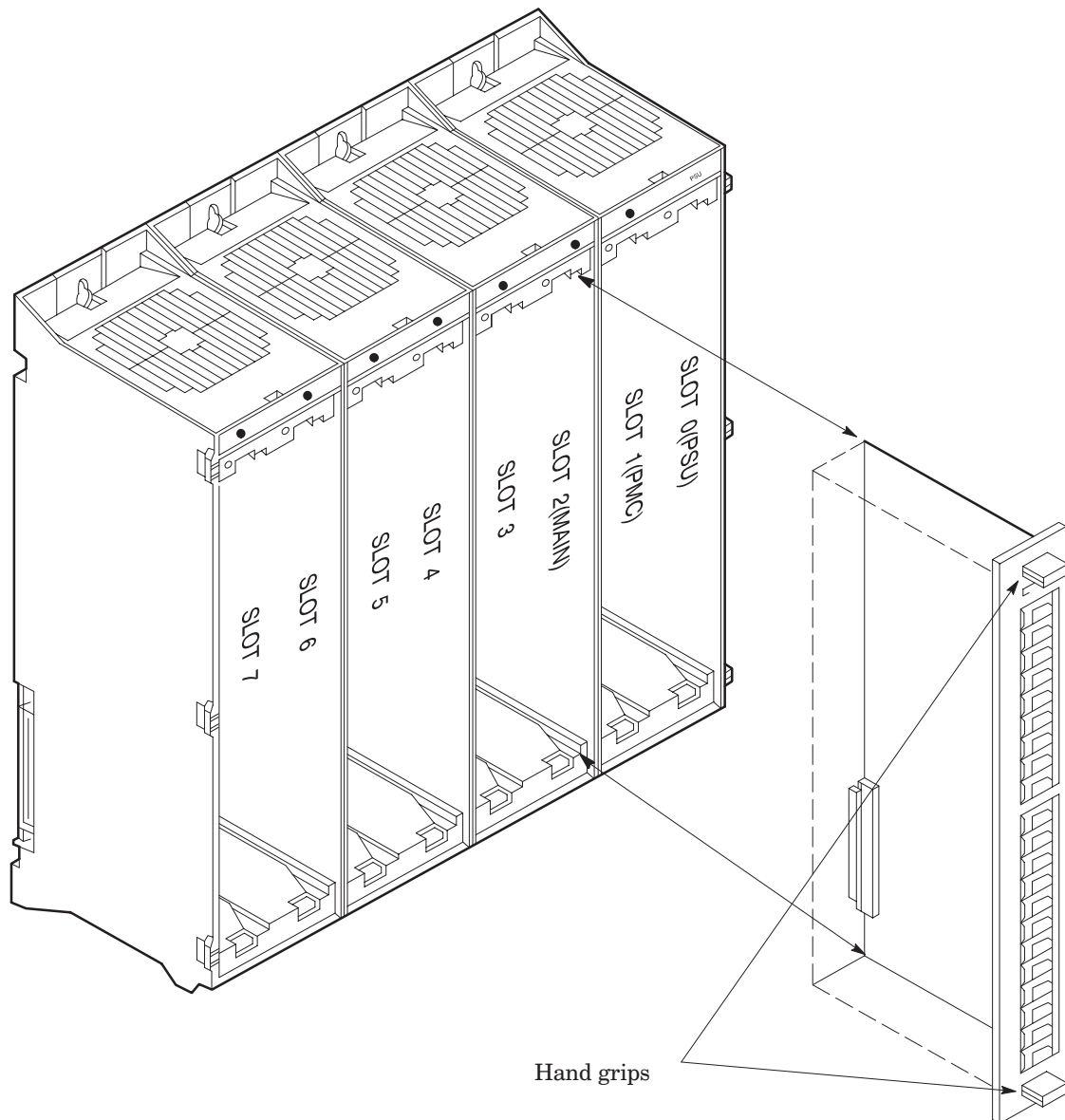
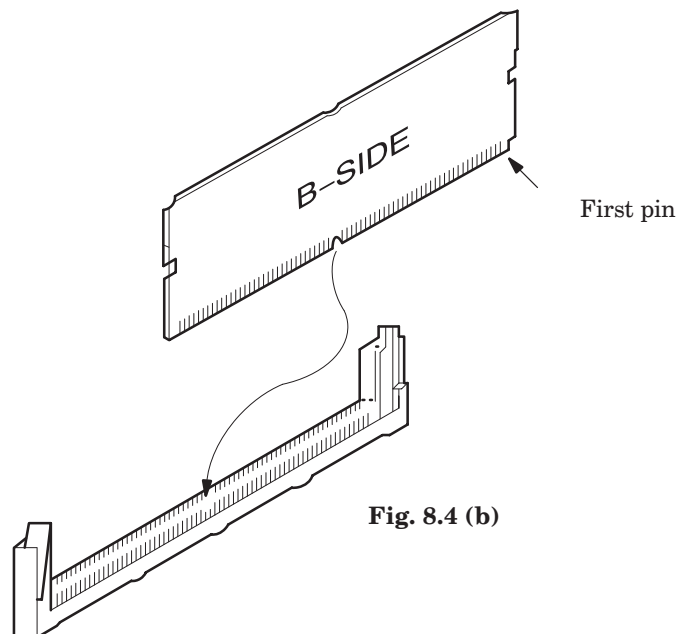
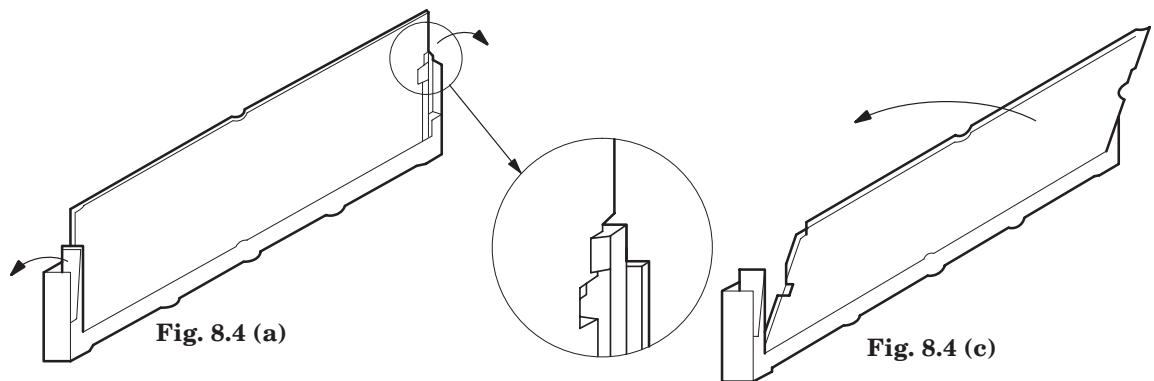

Fig. 8.3 Diagram of the Control Unit Printed Circuit Board

## 8.4 How to Replace the Modules

- (1) By pulling the latches located at both lengthwise edges of the module socket outwards, the module board will fall out diagonally due to pressure from the contact springs. (Refer to Fig. 8.4(a).)
- (2) When a leaning module board is touching a neighboring board, it may be difficult to remove. When this occurs, release the latches of the board being touched (as described in step (1)).
- (3) Now the module board is completely disconnected from the socket. Gently pull the module board straight (in the direction the board is leaning) out of the socket. Be careful when removing the module board since any kind of wrenching motion may cause damage to the socket or module contacts.
- (4) Insert the new module board diagonally into the socket. Insert the module board firmly until it is touching the bottom of the socket slot. (Refer to Fig. 8.4(b).)
- (5) While pushing on the upper edge of the module board, raise it until it is standing perpendicularly. (Refer to Fig. 8.4(c).)
- (6) Make sure that the latches at both ends of the module board are tightly locked. It is very important that the latches be locked properly. Insufficiently locked latches may result in a bad connection which in turn can lead to NC equipment operation errors.



## 8.5 How to Replace the Batteries

### 8.5.1 Procedure for replacing the dry cell for the control unit (memory back-up)

- (1) Use a lithium battery (ordering information : A02B-0120-K106).
- (2) Turn the machine (NC) power ON. (The battery can be replaced while the NC power is either on or off. To replace the battery while the NC power is off, briefly turn the NC power on and off beforehand and complete the replacement quickly. If the battery is left disconnected for too long while the NC power is off, the contents of NC memory will be lost.)
- (3) Remove the battery case on the front panel of the power unit. Hold and squeeze the top and bottom of the case while pulling it towards you.

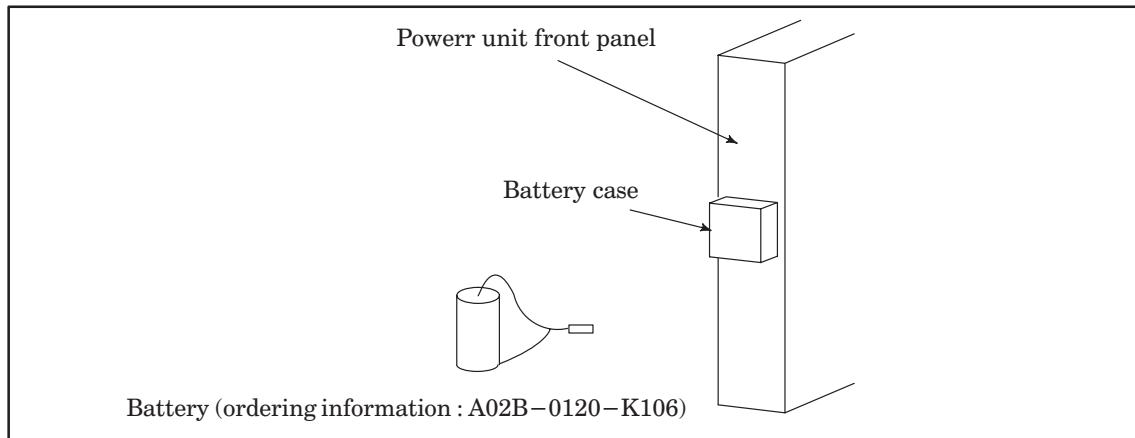

**Fig. 8.5.1 (a) Battery(1)**

- (4) Remove the connector attached to the battery.

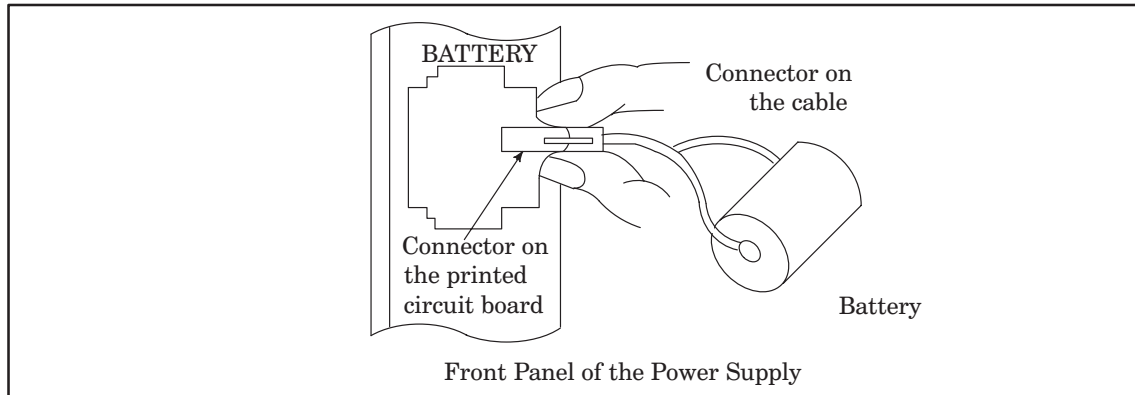
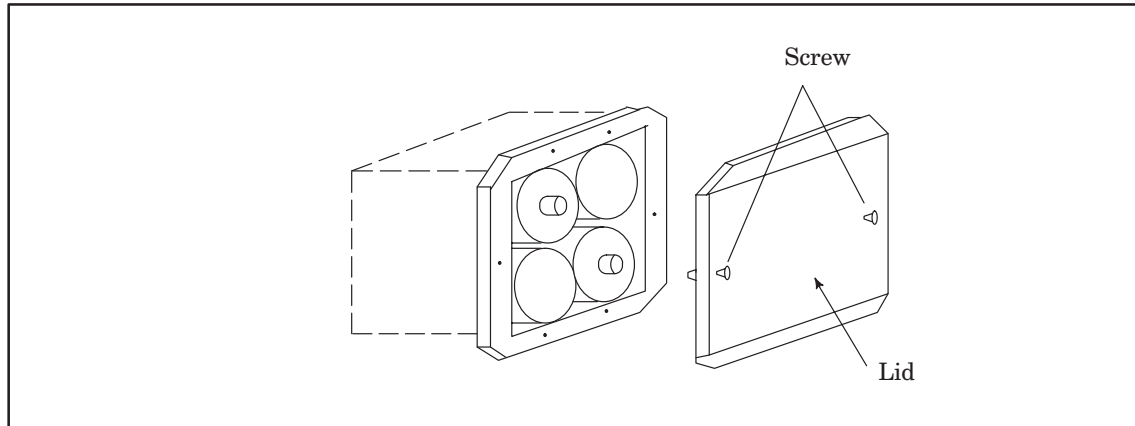

**Fig. 8.5.1 (b) Battery(2)**

- (5) Change the battery and reattach the connector.
- (6) Put the battery case back on.
- (7) Turn the machine (NC) power OFF.

### 8.5.2 Procedure for replacing the dry cell for the absolute pulse coder

- (1) Have 4 commercially available dry cell batteries ready.
- (2) Turn the machine (NC) power ON. (Change the batteries with the NC power ON. The recorded absolute position value will be lost if the batteries are changed with the power OFF.)
- (3) Loosen the battery case lid screws and remove the lid.  
Refer to the machine tool builders' reference manuals for the location of the battery case.
- (4) Change the dry cell batteries in the case. Take care to place the batteries facing in the correct direction. (Insert the batteries as shown in the diagram with 2 facing one way and 2 the other.)



**Fig. 8.5.2 Alkali Battery**

- (5) Having exchanged the batteries put the lid back on.
- (6) Turn the machine (NC) power OFF.



## 8.6 How to Replace the Fan Motor

- (1) Remove the control section printed circuit board underneath the fan to be replaced by referring to the removal procedure described in section 8.3.
- (2) There is a backplane inside the slot. The fan motor cable coming from above is connected to the backplane. Grasp the left and right side of the cable connector attached to the backplane and remove it.
- (3) Opening the upper lid of the control section rack Insert a phillips head screwdriver into the hole at the center front of the lid. The latch holding the cover in place can be released by prying the screwdriver in the direction shown in item (3) of Fig. 8.6.
- (4) Open the lid sufficiently and remove the fan motor. Since the fan itself is not screwed into the rack, it can be easily removed.
- (5) Install the new fan motor. Guide the fan motor cable through the hole and into the rack.
- (6) Close the lid until the latch locks.
- (7) Attach the fan motor cable to the connector on the back plane. At this time, affix the middle portion of the cable to the hooks at the back of the rack.
- (8) Reinsert the removed control section printed circuit board by following the directions described in section 8.3.

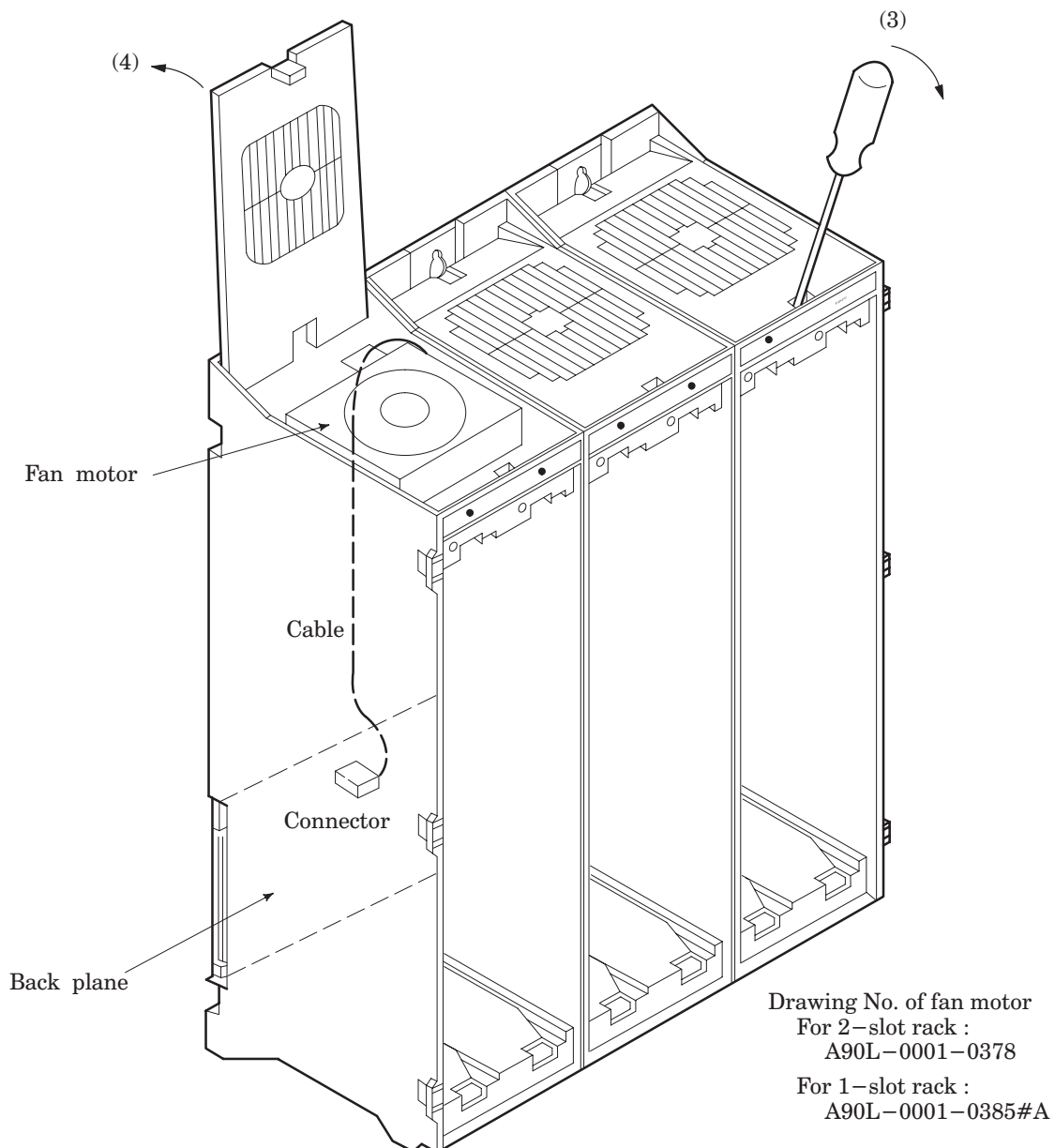

**Fig. 8.6 Fan Motor Replacement**

## 8.7 How to Replace the Card Cage in the Control Unit

- (1) Turn off the power supply and disconnect all the attached cables.
- (2) Unscrew and remove the screws holding the lower portion of the rack.
- (3) The screw holes in the upper portion of the rack are made for slide-off removal. Loosen the screws and remove the rack by lifting it up and away.
- (4) Temporarily position the new rack by guiding the screws through the holes in the upper portion of the rack.
- (5) Insert the screws for affixing the lower portion of the rack, then sufficiently tighten all the screws holding the rack.
- (6) Reconnect the cables to their original positions.

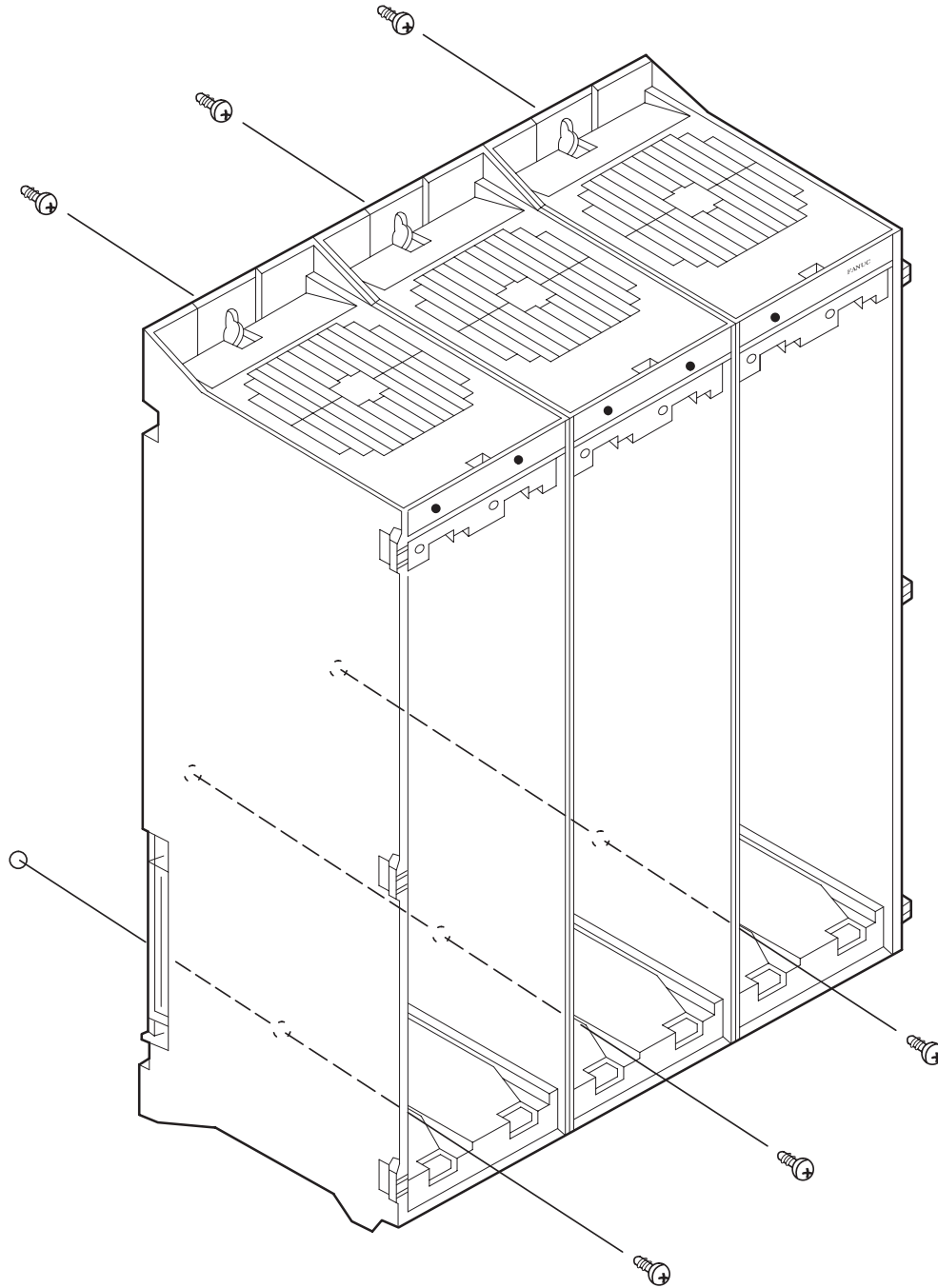

Fig. 8.7 Replacement of the Control Section Rack

## 8.8 How to Replace the MDI Keyboard

- (1) The small printed circuit board at the rear of the MDI keyboard can be seen from the back of the CRT/MDI control unit. There is a flat cable, coming from the soft keyboard, attached to this printed circuit board. Disconnect this cable.
- (2) Remove the cable attached to the power on/off button.
- (3) Remove the M3 screws from the front panel attached to the sheet metal panel of the CRT/MDI unit.
- (4) The keyboard is located in between the front panel and the sheet metal panel. The keyboard can now be removed (there are no screws holding the keyboard).
- (5) Insert the new keyboard into the front panel. Screw the front panel onto the sheet metal panel.
- (6) Reattach the power on/off cable and flat cable removed in steps (1) and (2) to their original positions.

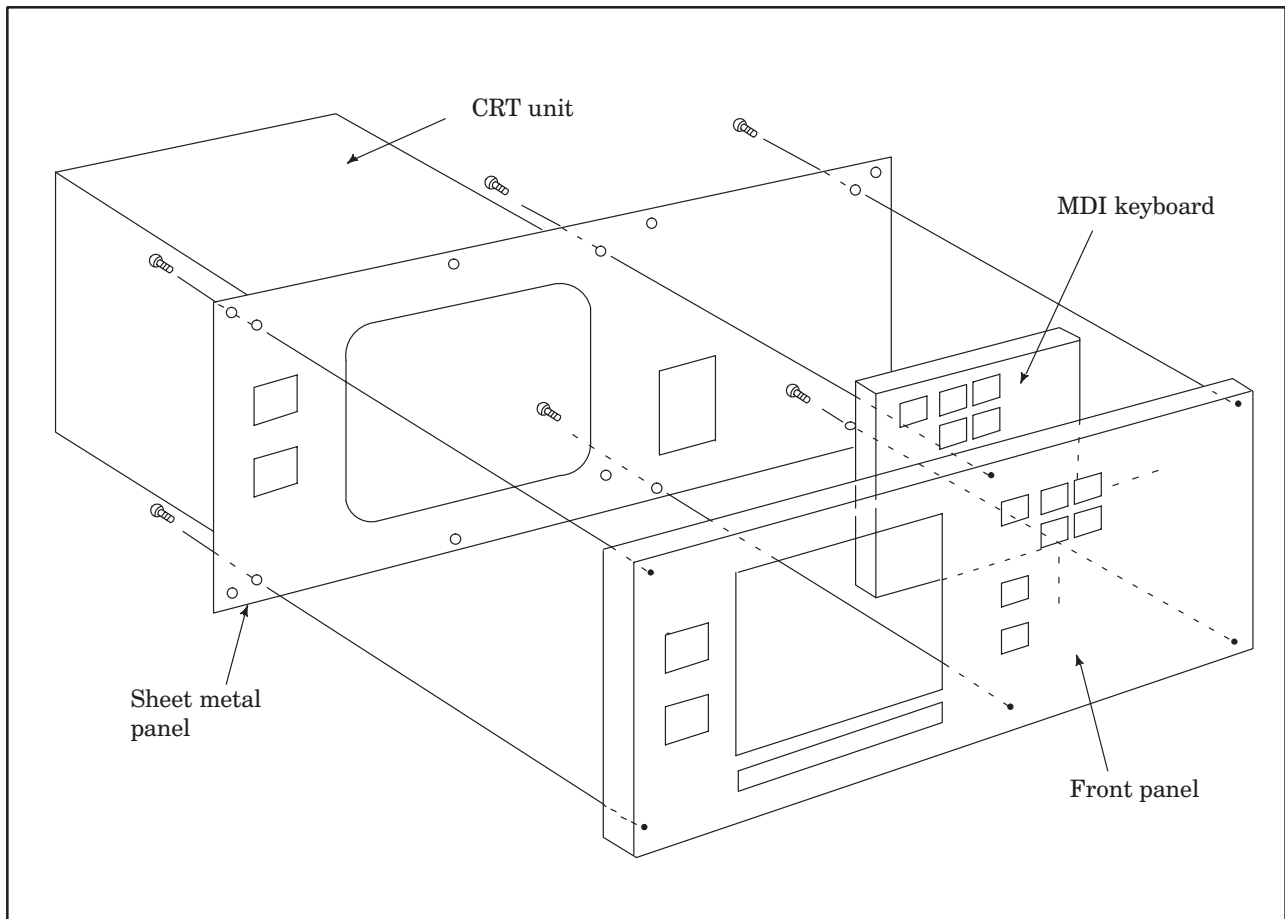

Fig. 8.8 MDI Keyboard Replacement

## 8.9 How to Replace the CRT Display

- (1) Disconnect the CRT unit power cable and the video signal cable.
- (2) When replacing a 9" monochrome CRT, remove the chloridized veneer cover and the four screws from the front of the CRT unit.
- (3) When replacing a 9" color CRT, remove the four screws in the front of the CRT unit.
- (4) When replacing a 14" color CRT, remove the two screws from the bottom of the CRT unit and pull it towards you.
- (5) Install the new CRT unit.
- (6) Reconnect the CRT power supply cable and video signal cable to their original positions.

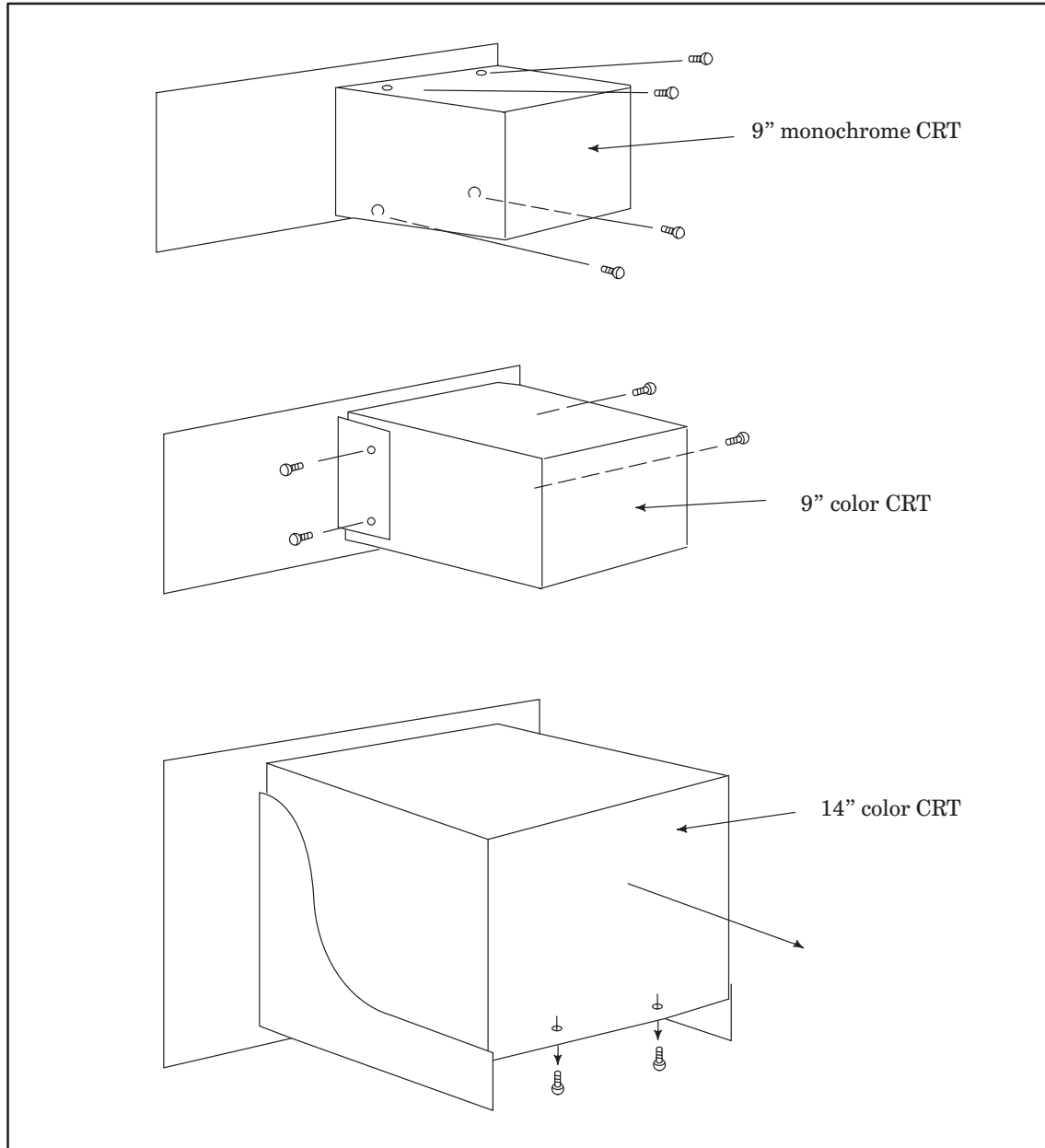

Fig. 8.9 Replacing the CRT Display

# APPENDIX

## APPENDIX 1. SYSTEM ALARMS

When the CNC disables subsequent operation due to a serious failure in the hardware or software, it enters the system alarm mode. The CNC stops normal operation to analyze the failure. Then the CNC displays the results of the analysis on the screen. This information is saved and can be referenced after the CNC is recovered from the failure and turned on again. Generally, it is difficult for the customer to recover the CNC system in the system alarm mode. Report the information displayed on the screen to the FANUC Service Center. Inform your FANUC Service center of the steps performed prior to the occurrence of the system alarm and the LED display on each PC board. This information is essential to correct diagnosis.

### 1.1 System Alarms When the CNC System Is Turned On

No.	Alarm message	Description	Action
1	ROM PARITY ERROR aaa bbb...	An error occurred during the F-ROM test. (A defective DRAM module for the main CPU occasionally causes this alarm.) aaa, bbb, ...: Number of the defective ROM	Rewrite the system data. Replace the F-ROM module.
2	RAM TEST: CNC stops without nothing being display after RAM TEST.	An error occurred during the RAM test for the servo module.	Replace the servo module.
3	RAM TEST: ERROR aaaaaa: wwwwwwww rrrrrrrr	An error occurred during the DRAM or high-speed SRAM module test for the main CPU. aaaaaa : Address wwwwwww : Written data rrrrrrr : Read data	
4	IMPROPER NUMBER OF AXIS	The number of controlled axes specified in the parameter is greater than the number of actually supported axes.	Check the axis installation or SIF modules. Also check the parameter setting.
5	LOADING CNC DATA (This message continues to blink.)	The CNC system program was incorrectly loaded. The main CPU is not provided with the SRAM module.	Rewrite the system data. Replace the F-ROM module.
6	LOAD SYSTEM LABEL : ERROR SAVE SYSTEM LABEL : ERROR LOAD PC PARAMETER : ERROR CLEAR FILE #n : ERROR LOAD FILES : ERROR FILE PREPARATION : ERROR CLEAR FILE : ERROR aaaa bbbb cccc (This is displayed after one of the messages above.)	A file read/write error occurred in memory.	
7	FILE INITIALIZE : NO FILE FILE PREPARATION : NO FILE CLEAR FILE : NO FILE	The required memory for storing files has not been installed.	
8	CHECK FILE ID : ERROR	An invalid identification code was specified for the type of memory for storing files.	

No.	Alarm message	Description	Action
9	FILE PREPARATION: NOT READY CLEAR FILE : NOT READY	Memory for storing files has not been correctly turned on. This message is normally displayed when an attempt is made to access a file after an error indicated by alarm 7 or 8 occurs.	
10	NO SYSTEM LABEL	A system label that includes the type and configuration of the system has not been reserved. This message is normally displayed when an attempt is made to access a system label after an error indicated by alarm 7 or 8 occurs.	
11	CHECK SYSTEM LABEL: ERROR	Invalid system label (See the description of system alarm 11 above for a system label.) This message is normally displayed when: <ul style="list-style-type: none"> <li>– The installed memory for storing files has not been initialized for the device.</li> <li>– The memory has not been initialized after it was entirely cleared.</li> </ul>	Initialize the system.
12	FILE #n : DATA BROKEN	The data in file n has been destroyed. This message is displayed when the CNC is turned off while the file is being accessed.	Clear the file and write data to the file again.
13	SLOTxx (yyyy) : xx = 00 to FF yyyy = 0000 to FFFF	The FBUS module is idle. (An FBUS module is a printed circuit board with slot number xx and identification number yyyy.) The low-order two digits of the ID represent the type of the PC board. For details of the relationship between the ID and the PC board, see Section 1.3.	Replace the FBUS module with a new one.
14	SLOTxx (yyyy) : ROM PARITY xx = 00 to FF yyyy = 0000 to FFFF	A RAM parity error occurred in the FBUS module. (An FBUS module is a printed circuit board with slot number xx and identification number yyyy.)	Replace the FBUS module with a new one.
15	SLOTxx (yyyy) : ROM PARITY xx = 00 to FF yyyy = 0000 to FFFF	A ROM parity error occurred in the FBUS module. (An FBUS module is a printed circuit board with slot number xx and identification number yyyy.)	Replace the ROM on the FBUS module with a new one.
16	SLOTxx (yyyy) : BUS ERROR xx = 00 A FF yyyy = 0000 A FFFF	A bus error occurred in the FBUS module. (An FBUS module is a printed circuit board with slot number xx and identification number yyyy.)	Replace the FBUS module or the ROM on the module with a new one.
17	SERVO ROM TEST : ERROR	An error occurred during the test of the area for the digital servo software for the F-ROM module.	

**NOTE** When a system alarm is issued in the CNC system, the corresponding message appears on the screen. Then the CNC system enters the IPL mode and displays the IPL initial menu. Generally, normal operation can be restarted only after the cause of the system error has been eliminated.

## 1.2 System Alarms While the CNC System Is Operating

### 1.2.1 System alarm screen

When the CNC disables subsequent operation due to a serious failure in the hardware or software, it enters the system alarm mode. Then the CNC displays the information shown below on the screen.

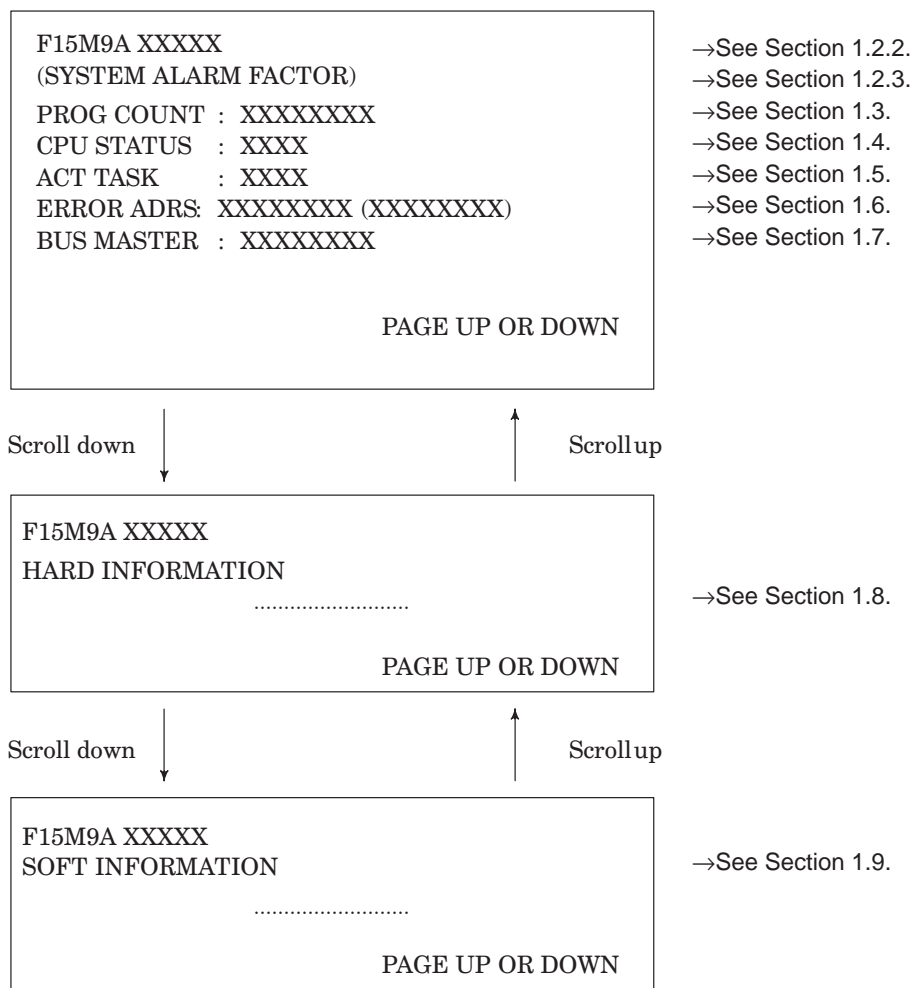

### 1.2.2 Software series and edition

Character string XXXXX on the first line of the screen shows the series and edition of the software.



## 1.2.3 System alarms (SYSTEM ALARM FACTOR)

(1)

No.	Alarm message	Description	Action
1	TRAP 15	The system software was abnormally operating.	
2	ADDRESS ERROR	An address error occurred.	
3	ILLEGAL INSTRUCTION	An attempt was made to execute a non-executable instruction.	
4	ZERO DIVIDE	Division was attempted with divisor 0.	
5	CHECK INSTRUCTION	An overflow occurred in the register.	
6	TRAPV INSTRUCTION	An overflow trap occurred.	
7	PRIVILEGE VIOLATION	Violation of a privileged instruction occurred.	
8	TRACE	The CPU entered the trace mode.	
9	L1111 EMUL.	An attempt was made to execute an instruction with a code that cannot be used.	
10	L1010 EMUL.	An attempt was made to execute an instruction with a code that cannot be used.	
11	UNASSIGNED TRAP	An undefined trap instruction was executed.	
12	UNASSIGNED INTERRUPT	An undefined interrupt occurred.	
13	SPURIOUS INTERRUPT	An error occurred during the DRAM or high-speed SRAM test.	
14	DRAM SUM ERROR	A checksum error occurred.	
15	WATCHDOG ALARM	A watchdog error occurred.	
16	BUS ERROR	A bus error occurred.	
17	NOISE ON POWER SUPPLY	The power has dropped below the specified voltage.	
18	RAM PARITY	A RAM parity error occurred.	
19	ROM PARITY aaa bbb : PC010	A ROM parity error occurred in the PMC. aaa, bbb: Number of the defective ROM	
20	RAM PARITY <a.RAM> bb (yyyyyy) : PC020	A RAM parity error occurred in the PMC. a.RAM : Type of the RAM parity check B.RAM : Basic RAM board O.RAM : Optional RAM board S.RAM : Static RAM board P.RAM : PMC RAM board bb : Information about the RAM parity error	
21	BUS ERROR xxxxxx (yyyyyy) : PC040	A bus error occurred in the PMC. (An address that cannot be used was accessed.)	
22	ADR ERROR xxxxxx (yyyyyy) : PC040	An address error occurred in the PMC. (An odd address was accessed.)	

No.	Alarm message	Description	Action
23	IRG ERROR (yyyyyy) : PC040	The PMC CPU attempted to execute an instruction which cannot be executed.	
24	ZDV ERROR (yyyyyy) : PC040	The PMC CPU attempted to divide a value by zero.	
25	CHK ERROR (yyyyyy) : PC040	A register exceeding a range was detected when the PMC CPU checked the register limits.	
26	TPV ERROR (yyyyyy) : PC040	An overflow trap occurred in the PMC.	
27	PRV ERROR (yyyyyy) : PC040	Violation of a privileged instruction occurred in the PMC.	
28	TRC ERROR (yyyyyy) : PC040	The PMC CPU entered the trace mode.	
29	L10 ERROR (yyyyyy) : PC040	An attempt was made to execute an instruction with code Axxx in the PMC.	
30	L11 ERROR (yyyyyy) : PC040	An attempt was made to execute an instruction with code Fxxx in the PMC.	
31	NAE ERROR (yyyyyy) : PC040	An unexpected interrupt occurred in the PMC.	
32	SPI ERROR (yyyyyy) : PC040	An unaccountable interrupt occurred in the PMC.	
33	NTP ERROR (yyyyyy) : PC040	An unexpected trap occurred in the PMC.	
34	SLC ERROR aa : PC050	A DI/DO error occurred. aa: Information about the DI/DO error	
35	PC500 WATCHDOG ALARM	A watchdog error occurred in the PMC.	

(xxxxxx: Accessed address, yyyyyy: Address at which an error occurred)

One of the following messages is displayed to indicate the CPU where a system alarm was issued. This message is displayed after the alarm message.

Message	Description
CNC-MAIN	A system alarm was issued in the main CPU of the CNC.
CNC-SUB	A system alarm was issued in the subordinate CPU of the CNC. (This message can be displayed only when a system where a subordinate CPU is installed is used.)
CNC-AXIS#n	A system alarm was issued in axis control CPU n of the CNC. (This message can be displayed only when a system which controls multiple axes is used.)
SRVO-CPU#n	A system alarm was issued in digital servo CPU n.

If a RAM parity alarm was issued, one of the following messages is displayed to indicate the relevant hardware. This message is displayed after the message which indicates the CPU where a system alarm was issued.

Message	Description
FILE-RAM	A RAM parity alarm was issued in the RAM for storing part programs.
DRAM	A DRAM parity alarm was issued in the RAM for storing the CNC control program.
SRAM	A RAM parity alarm was issued in the high-speed SRAM for storing the CNC control program.

(2)

Alarm message	Description	Action
SYSTEM EMERGENCY	A serious failure occurred in the FBUS module.	

The following message is displayed after the above message.

P-SLOT: nn L-SLOT: mm SOFT: AAAA#nnnn

Message	Description
P-SLOT	Number of the slot in which the module is inserted
L-SLOT	Logical slot number for the module
SOFT	Software used for the module

(3)

Message	Description	Action
NON MASK INTERRUPT	An unaccountable alarm was issued.	

The HARD INFORMATION screen is displayed to indicate the hardware status, preceded by the message above (see Section 1.8).

### 1.3 Program Counter (PROG COUNT)

The program counter of the CPU where an error occurred is displayed. When an error occurs in the digital servo CPU, 0 is displayed.

### 1.4 CPU Status (CPU STATUS)

The status of the CPU where an error occurred is displayed. When an error occurs in the digital servo CPU, 0 is displayed.

### 1.5 User Number for the Active Task (ACT TASK)

The user number for the active task in the CPU where an error occurred is displayed. When an error occurs in the digital servo CPU, 0 is displayed.

### 1.6 Address at which an Error Occurred (ERROR ADRS)

The address at which a bus error or RAM parity error occurred is displayed. 0 is displayed when an address error other than a bus error or RAM parity error occurs. 0 is displayed also when an address error occurs in the digital servo CPU. When the CPU detects the address at which a bus error occurred, the address is displayed in parentheses.

### 1.7 Master CPU of the Bus (BUS MASTER)

One of the following messages is displayed to indicate the master CPU of the bus when an error occurred.

Message	Description
CNC-MAIN	The main CPU of the CNC was the master CPU of the bus.
CNC-SUB	The subordinate CPU of the CNC was the master CPU of the bus. (This message can be displayed only when a system where a subordinate CPU is installed is used.)
OTHER	The CPU other than the two CPUs above was the master CPU of the bus.

## 1.8 Hardware Status (HARD INFORMATION)

The hardware status when an error occurred is displayed. The display extends over two pages.

(Displayed information)

Information	Display	Remarks
SLOT_IO for each MODULE	HARD INFORMATION 1	Status of the PC board to be installed
ABC-REG1	HARD INFORMATION 2	Status of the main CPU or sub-CPU when an error occurs
ABC2-REG1		
ABC-REG2		
ABC-REG5		
AMAC-REG(1-6)		

## 1.9 Software Status (SOFT INFORMATION)

The software status when an error occurred is displayed. The display extends over two pages.

(Displayed information)

Information	Number of words	Remarks
User stack	32	User stack when an alarm was issued
Data register	16	Data register when an alarm was issued
Address register	16	Address register when an alarm was issued
Supervisor stack	32	Supervisor stack when an alarm was issued

## APPENDIX 2. DISPLAYING THE SYSTEM LOG SCREEN

When a system alarm is issued, the CNC saves information about the factor and details of the alarm. This information can also be referenced when the CNC is operating normally.

Displayed information

When the SYSTEM LOG screen is selected from the SERVICE menu, information about the factors and details of past system alarms is displayed. This information is displayed in the same format as for when a system alarm is issued.

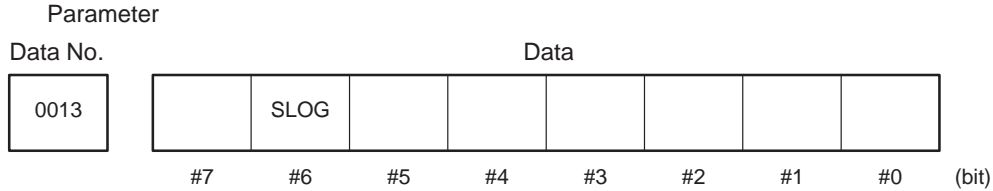

Setting input

Data type : Bit

SLOG The system log screen is:

- 0: Not displayed. (The SYSTEM LOG soft key is also cleared from the screen.)
- 1: Displayed.

**NOTE** Nothing is displayed on the system log screen if no system alarm has occurred in the system. If SLOG is set to 0, the system log is not displayed.

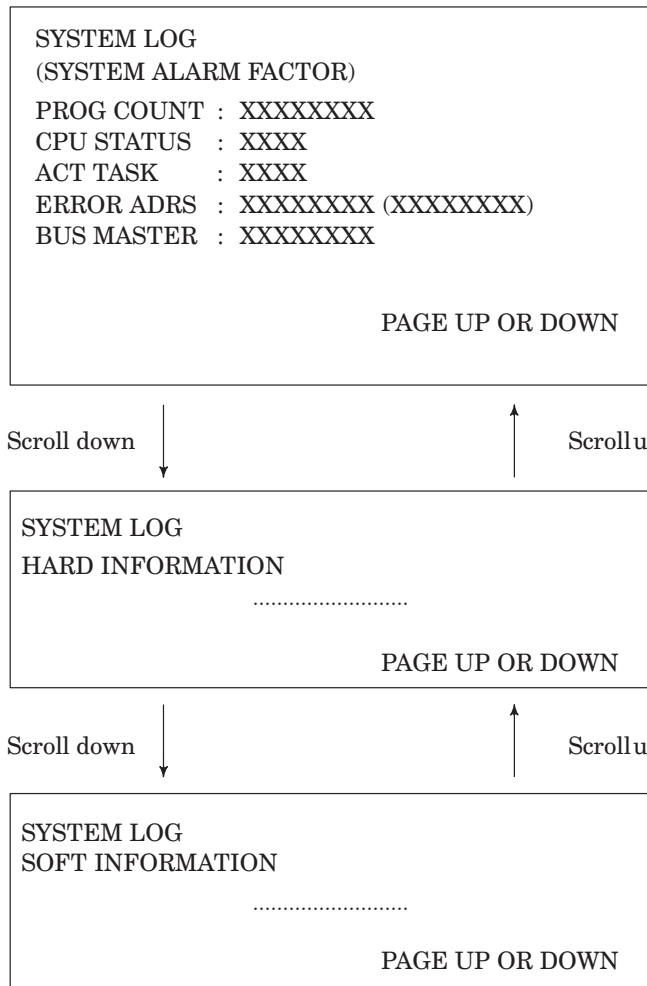

## APPENDIX 3. SIGNAL INTERFACE LIST BETWEEN CNC AND PMC

(1) BMI Signal list (In case of FS15-T and FS15-M)

BMI-DI1

DGN No.	7	6	5	4	3	2	1	0
0	ERS	RRW	*SP	*ESP	SKIP1	UINT	*CSL	*IT
1	SKIP4	SKIP3	SKIP2	AE3	AE2	AE1	*BSL	*AIT
2	ZRN	BRN	SRN	MOVL	TCHIN			
3	AGJ	EDT	MEM	T	D	J	H	S
4	MLK	DLK	ABS	OVC	SBK	BDT1	DRN	AFL
5	KEY4	KEY3	KEY2	KEY1	F1D	FFIN	FIN	ST
6	RT	ROV2	ROV1	MP4	MP2	MP1		
7	BDT9	BDT8	BDT7	BDT6	BDT5	BDT4	BDT3	BDT2
8	TMRON		PRC				*CSMZ	*CHF
9	TLSKP	TL64	TL32	TL16	TL08	TL04	TL02	TL01
10	TLRST	OMEP	OME		HS3D	HS3C	HS3B	HS3A
11	HS2D	HS2C	HS2B	HS2A	HS1D	HS2C	HS1B	HS2A
12	*FV7	*FV6	*FV5	*FV4	*FV3	*FV2	*FV1	*FV0
13	*AFV7	*AFV6	*AFV5	*AFV4	*AFV3	*AFV2	*AFV1	*AFV0

		BMI-DI2							
		7	6	5	4	3	2	1	0
14		*JV15	*JV14	*JV13	*JV12	*JV11	*JV10	*JV9	*JV8
15		*JV7	*JV6	*JV5	*JV4	*JV3	*JV2	*JV1	*JV0
16		AJSTB	-AJ	+AJ	AJA12	AJA11	AJA10	AJA9	AJA8
17		AJA7	AJA6	AJA5	AJA4	AJA3	AJA2	AJA1	AJA0
18		AJP2D	AJP2C	AJP2B	AJP2A	AJP1D	AJP1C	AJP1B	AJP1A
19		*BECLP	*BEUCL		WN16	WN8	WN4	WN2	WN1
20							DIST26	DIST25	DIST24
21		DIST23	DIST22	DIST21	DIST20	DIST19	DIST18	DIST17	DIST16
22		DIST15	DIST14	DIST13	DIST12	DIST11	DIST10	DIST9	DIST8
23		DIST7	DIST6	DIST5	DIST4	DIST3	DIST2	DIST1	DIST0
24		RISGN			RI12	RI11	RI10	RI9	RI8
25		RI7	RI6	RI5	RI4	RI3	RI2	RI1	RI0
26		WOSET	GS4	GS5	GS1	*SECLP	*SEUCL		SPSTP
27		CDV7	CDV6	CDV5	CDV4	CDV3	CDV2	CDV1	CDV0
28							SPC	SPB	SPA

		BMI-DI3							
		7	6	5	4	3	2	1	0
29									
30									
31									
32		EISTB	ERDRQ	EOREND			EXSTP	EXRD	EXPUN
33		EIA7	EIA6	EIA5	EIA4	EIA3	EIA2	EIA1	EIA0
34		EID47	EID46	EID45	EID44	EID43	EID42	EID41	EID40
35		EID39	EID38	EID37	EID36	EID35	EID34	EID33	EID32
36		EID31	EID30	EID29	EID28	EID27	EID26	EID25	EID24
37		EID23	EID22	EID21	EID20	EID19	EID18	EID17	EID16
38		EID15	EID14	EID13	EID12	EID11	EID10	EID9	EID8
39		EID7	EID6	EID5	EID4	EID3	EID2	EID1	EID0
40									
41									
42									TL256
43		TL128							



		BMI-DI4							
		7	6	5	4	3	2	1	0
44									
45									
46									
47									
48		UI031	UI030	UI029	UI028	UI027	UI026	UI025	UI024
49		UI023	UI022	UI021	UI020	UI019	UI018	UI017	UI016
50		UI015	UI014	UI013	UI012	UI011	UI010	UI009	UI008
51		UI007	UI006	UI005	UI004	UI003	UI002	UI001	UI000
52		UI131	UI130	UI129	UI128	UI127	UI126	UI125	UI124
53		UI123	UI122	UI121	UI120	UI119	UI118	UI117	UI116
54		UI115	UI114	UI113	UI112	UI111	UI110	UI109	UI108
55		UI107	UI106	UI105	UI104	UI103	UI102	UI101	UI100
56		UI231	UI230	UI229	UI228	UI227	UI226	UI225	UI224
57		UI223	UI222	UI221	UI220	UI219	UI218	UI217	UI216
58		UI215	UI214	UI213	UI212	UI211	UI210	UI209	UI208

		BMI-DI5							
		7	6	5	4	3	2	1	0
59		UI207	UI206	UI205	UI204	UI203	UI202	UI201	UI200
60		UI331	UI330	UI329	UI328	UI327	UI326	UI325	UI324
61		UI323	UI322	UI321	UI320	UI319	UI318	UI317	UI316
62		UI315	UI314	UI313	UI312	UI311	UI310	UI309	UI308
63		UI307	UI306	UI305	UI304	UI303	UI302	UI301	UI300
64		DTCH1	*SVF1	*DEC1	*IT1	*-ED1	*+ED1	*-L1	*+L1
65				*CL1	PK1	MLK1	MI1	-J1	+J1
66									
67									
68		DTCH2	*SVF2	*DEC2	*IT2	*-ED2	*+ED2	*-L2	*+L2
69				*CL2	PK2	MLK2	MI2	-J2	+J2
70									
71									
72		DTCH3	*SVF3	*DEC3	*IT3	*-ED3	*+ED3	*-L3	*+L3
73				*CL3	PK3	MLK3	MI3	-J3	+J3

		BMI-DI6							
		7	6	5	4	3	2	1	0
74									
75									
76		DTCH4	*SVF4	*DEC4	*IT4	*-ED4	*+ED4	*-L4	*+L4
77				*CL4	PK4	MLK4	MI4	-J4	+J4
78									
79									
80		DTCH5	*SVF5	*DEC5	*IT5	*-ED5	*+ED5	*-L5	*+L5
81				*CL5	PK5	MLK5	MI5	-J5	+J5
82									
83									
84		DTCH6	*SVF6	*DEC6	*IT6	*-ED6	*+ED6	*-L6	*+L6
85				*CL6	PK6	MLK6	MI6	-J6	+J6
86									
87									

		BMI-DO1							
		7	6	5	4	3	2	1	0
200		MA	SA	OP	STL	SPL	RST	AL	RWD
201		CSS	THRD	RPD	TAP	INCH	DST	IPEN	DEN
202		MZRN	MBRN	MSRN	MMOVL				
203		MAGL	MEDT	MMEM	MT	MD	MJ	MH	MS
204		MMLK	MDLK	MABS		MSBK	MBDT1	MDRN	MAFL
205		MBDT9	MBDT8	MBDT7	MBDT6	MBDT5	MBDT4	MBDT3	MBDT2
206		MSALM	EGPSALM	DIALM	SYALM	OTALM	OHALM	SVALM	PSALM
207		TLCHB	TLCHA	ESEND	RPBSY			BCLP	BUCLP
208		SSP	SRV	FMF	EF	BF	TF	SF	MF
209		DM30	DM02	DM01	DM00				
210		R015	R014	R013	R012	R011	R010	R09	R08
211		R07	R06	R05	R04	R03	R02	R01	R00
212		AR15	AR14	AR13	AR12	AR11	AR10	AR9	AR8
213		AR7	AR6	AR5	AR4	AR3	AR2	AR1	AR0
214		MR15	MR14	MR13	MR12	MR11	MR10	MR9	MR8

		BMI-DO2							
		7	6	5	4	3	2	1	0
215		MR7	MR6	MR5	MR4	MR3	MR2	MR1	MR0
216		M31	M30	M29	M28	M27	M26	M25	M24
217		M23	M22	M21	M20	M19	M18	M17	M16
218		M15	M14	M13	M12	M11	M10	M9	M8
219		M7	M6	M5	M4	M3	M2	M1	M0
220		S31	S30	S29	S28	S27	S26	S25	S24
221		S23	S22	S21	S20	S19	S18	S17	S16
222		S15	S14	S13	S12	S11	S10	S9	S8
223		S7	S6	S5	S4	S3	S2	S1	S0
224		T31	T30	T29	T28	T27	T26	T25	T24
225		T23	T22	T21	T20	T19	T18	T17	T16
226		T15	T14	T13	T12	T11	T10	T9	T8
227		T7	T6	T5	T4	T3	T2	T1	T0
228		B31	B30	B29	B28	B27	B26	B25	B24
229		B23	B22	B21	B20	B19	B18	B17	B16

		BMI-DO3							
		7	6	5	4	3	2	1	0
230		B15	B14	B13	B12	B11	B10	B9	B8
231		B7	B6	B5	B4	B3	B2	B1	B0
232		EOSTB		EIREND					
233		EOA7	EOA6	EOA5	EOA4	EOA3	EOA2	EOA1	EOA0
234		EOD47	EOD46	EOD45	EOD44	EOD43	EOD42	EOD41	EOD40
235		EOD39	EOD38	EOD37	EOD36	EOD35	EOD34	EOD33	EOD32
236		EOD31	EOD30	EOD29	EOD28	EOD27	EOD26	EOD25	EOD24
237		EOD23	EOD22	EOD21	EOD20	EOD19	EOD18	EOD17	EOD16
238		EOD15	EOD14	EOD13	EOD12	EOD11	EOD10	EOD9	EOD8
239		EOD7	EOD6	EOD5	EOD4	EOD3	EOD2	EOD1	EOD0
240		BTAL	PBATL	PBATZ		SPAL8	SPAL4	SPAL2	SPAL1
241									
242			SPCO	SPBO	SPAO	*REEL	SPAL	SCLP	SUCLP
243									
244									

		BMI-DO4							
		7	6	5	4	3	2	1	0
245									
246									
247									
248		UO031	UO030	UO029	UO028	UO027	UO026	UO025	UO024
249		UO023	UO022	UO021	UO020	UO019	UO018	UO017	UO016
250		UO015	UO014	UO013	UO012	UO011	UO010	UO009	UO008
251		UO007	UO006	UO005	UO004	UO003	UO002	UO001	UO000
252		UO131	UO130	UO129	UO128	UO127	UO126	UO125	UO124
253		UO123	UO122	UO121	UO120	UO119	UO118	UO117	UO116
254		UO115	UO114	UO113	UO112	UO111	UO110	UO109	UO108
255		UO107	UO106	UO105	UO104	UO103	UO102	UO101	UO100
256		UO231	UO230	UO229	UO228	UO227	UO226	UO225	UO224
257		UO223	UO222	UO221	UO220	UO219	UO218	UO217	UO216
258		UO215	UO214	UO213	UO212	UO211	UO210	UO209	UO208
259		UO207	UO206	UO205	UO204	UO203	UO202	UO201	UO200

	BMI-DO5							
	7	6	5	4	3	2	1	0
260	UO331	UO330	UO329	UO328	UO327	UO326	UO325	UO324
261	UO323	UO322	UO321	UO320	UO319	UO318	UO317	UO316
262	UO315	UO314	UO313	UO312	UO311	UO310	UO309	UO308
263	UO307	UO306	UO305	UO304	UO303	UO302	UO301	UO300
264		INP1	ZP41	ZP31	MD1	MV1	ZP21	ZP1
265							MMLK1	MMI1
266								
267								
268		INP2	ZP42	ZP32	MD2	MV2	ZP22	ZP2
269							MMLK2	MMI2
270								
271								
272		INP3	ZP43	ZP33	MD3	MV3	ZP23	ZP3
273							MMLK3	MMI3
274								



		BMI-DO6							
		7	6	5	4	3	2	1	0
275									
276		INP4	ZP44	ZP34	MD4	MV4	ZP24	ZP4	
277								MMLK4	MMI4
278									
279									
280		INP5	ZP45	ZP35	MD5	MV5	ZP25	ZP5	
281								MMLK5	MMI5
282									
283									
284		INP6	ZP46	ZP36	MD6	MV6	ZP26	ZP6	
285								MMLK6	MMI6
286									
287									

## (2) BMI signal list (In case of FS15-TT)

		BMI-DI1							
		7	6	5	4	3	2	1	0
00						SKIP1 #1	UINT #1	*CSL #1	
01					AE3 #1	AE2 #1	AE1 #1	*BSL #1	*AIT #1
02									
03									
04					OVC #1		BDT1 #1		
05								FIN #1	
06									
07		BDT9 #1	BDT8 #1	BDT7 #1	BDT6 #1	BDT5 #1	BDT4 #1	BDT3 #1	BDT2 #1
08		TMROM						*CSMZ #1	*CHF #1
09		TLSKP #1	TL64 #1	TL32 #1	TL16 #1	TL8 #1	TL4 #1	TL2 #1	TL1 #1
10		TLRST #1							
11									
12		*FV7 #1	*FV6 #1	*FV5 #1	*FV4 #1	*FV3 #1	*FV2 #1	*FV1 #1	*FV0 #1
13		*AFV7 #1	*AFV6 #1	*AFV5 #1	*AFV4 #1	*AFV3 #1	*AFV2 #1	*AFV1 #1	*AFV0 #1
14									
15									

**NOTE** There are some signals which are provided for the first and second tool posts respectively and they provide just the same function.

These signals are identified by symbol #1 or #2 which is affixed to their names. Symbol #1 shows a signal exclusively provided for the first tool post, while symbol #2 shows a signal exclusively provided for the second tool post.

		BMI-DI2							
		7	6	5	4	3	2	1	0
16									
17									
18									
19				WN16 #1	WN8 #1	WN4 #1	WN2 #1	WN1 #1	
20									
21									
22									
23									
24	RISGN #1			RI12 #1	RI11 #1	RI10 #1	RI9 #1	RI8 #1	
25	RI7 #1	RI6 #1	RI5 #1	RI4 #1	RI3 #1	RI2 #1	RI1 #1	RI0 #1	
26									
27									
28									
29									
30									
31									

		BMI-DI3							
		7	6	5	4	3	2	1	0
32	UI031 #1	UI030 #1	UI029 #1	UI028 #1	UI027 #1	UI026 #1	UI025 #1	UI024 #1	
33	UI023 #1	UI022 #1	UI021 #1	UI020 #1	UI019 #1	UI018 #1	UI017 #1	UI016 #1	
34	UI015 #1	UI014 #1	UI013 #1	UI012 #1	UI011 #1	UI010 #1	UI009 #1	UI008 #1	
35	UI007 #1	UI006 #1	UI005 #1	UI004 #1	UI003 #1	UI002 #1	UI001 #1	UI000 #1	
36	UI131 #1	UI130 #1	UI129 #1	UI128 #1	UI127 #1	UI126 #1	UI125 #1	UI124 #1	
37	UI123 #1	UI122 #1	UI121 #1	UI120 #1	UI119 #1	UI118 #1	UI117 #1	UI116 #1	
38	UI115 #1	UI114 #1	UI113 #1	UI112 #1	UI111 #1	UI110 #1	UI109 #1	UI108 #1	
39	UI107 #1	UI106 #1	UI105 #1	UI104 #1	UI103 #1	UI102 #1	UI101 #1	UI100 #1	
40	UI231 #1	UI230 #1	UI229 #1	UI228 #1	UI227 #1	UI226 #1	UI225 #1	UI224 #1	
41	UI223 #1	UI222 #1	UI221 #1	UI220 #1	UI219 #1	UI218 #1	UI217 #1	UI216 #1	
42	UI215 #1	UI214 #1	UI213 #1	UI212 #1	UI211 #1	UI210 #1	UI209 #1	UI208 #1	
43	UI207 #1	UI206 #1	UI205 #1	UI204 #1	UI203 #1	UI202 #1	UI201 #1	UI200 #1	
44	*CHLD	CHPST			*CHP8	*CHP4	*CHP2	*CHP0	
45	UI323 #1	UI322 #1	UI321 #1	UI320 #1	UI319 #1	UI318 #1	UI317 #1	UI316 #1	
46	UI315 #1	UI314 #1	UI313 #1	UI312 #1	UI311 #1	UI310 #1	UI309 #1	UI308 #1	
47	UI307 #1	UI306 #1	UI305 #1	UI304 #1	UI303 #1	UI302 #1	UI301 #1	UI300 #1	

		BMI-DI4							
		7	6	5	4	3	2	1	0
48						SKIP1 #2	UINT #2	*CSL #2	
49					AE3 #2	AE2 #2	AE1 #2	*BSL #2	*AIT #2
50									
51									
52					OVC #2		BDT1 #2		
53								FIN #2	
54									
55		BDT9 #2	BDT8 #2	BDT7 #2	BDT6 #2	BDT5 #2	BDT4 #2	BDT3 #2	BDT2 #2
56								*CSMZ #2	*CHF #2
57		TLSKP #2	RITL64 #2	TL32 #2	TL16 #2	TL8 #2	TL4 #2	TL2 #2	TL1 #2
58		TLRST #2							
59									
60		*FV7 #2	*FV6 #2	*FV5 #2	*FV4 #2	*FV3 #2	*FV2 #2	*FV1 #2	*FV0 #2
61		*AFV7 #2	*AFV6 #2	*AFV5 #2	*AFV4 #2	*AFV3 #2	*AFV2 #2	*AFV1 #2	*AFV0 #2
62									
63									

		BMI-DI5							
		7	6	5	4	3	2	1	0
64									
65									
66									
67				WN16 #2	WN8 #2	WN4 #2	WN2 #2	WN1 #2	
68									
69									
70									
71									
72	RISGN #2			R12 #2	R11 #2	R10 #2	R9 #2	R8 #2	
73	R17 #2	R16 #2	R15 #2	R14 #2	R13 #2	R12 #2	R11 #2	R10 #2	
74									
75									
76									
77									
78									
79									

BMI-DI6

	7	6	5	4	3	2	1	0
80	UI031 #2	UI030 #2	UI029 #2	UI028 #2	UI027 #2	UI026 #2	UI025 #2	UI024 #2
81	UI023 #2	UI022 #2	UI021 #2	UI020 #2	UI019 #2	UI018 #2	UI017 #2	UI016 #2
82	UI015 #2	UI014 #2	UI013 #2	UI012 #2	UI011 #2	UI010 #2	UI009 #2	UI008 #2
83	UI007 #2	UI006 #2	UI005 #2	UI004 #2	UI003 #2	UI002 #2	UI001 #2	UI000 #2
84	UI131 #2	UI130 #2	UI129 #2	UI128 #2	UI127 #2	UI126 #2	UI125 #2	UI124 #2
85	UI123 #2	UI122 #2	UI121 #2	UI120 #2	UI119 #2	UI118 #2	UI117 #2	UI116 #2
86	UI115 #2	UI114 #2	UI113 #2	UI112 #2	UI111 #2	UI110 #2	UI109 #2	UI108 #2
87	UI107 #2	UI106 #2	UI105 #2	UI104 #2	UI103 #2	UI102 #2	UI101 #2	UI100 #2
88	UI231 #2	UI230 #2	UI229 #2	UI228 #2	UI227 #2	UI226 #2	UI225 #2	UI224 #2
89	UI223 #2	UI222 #2	UI221 #2	UI220 #2	UI219 #2	UI218 #2	UI217 #2	UI216 #2
90	UI215 #2	UI214 #2	UI213 #2	UI212 #2	UI211 #2	UI210 #2	UI209 #2	UI208 #2
91	UI207 #2	UI206 #2	UI205 #2	UI204 #2	UI203 #2	UI202 #2	UI201 #2	UI200 #2
92	UI331 #2	UI330 #2	UI329 #2	UI328 #2	UI327 #2	UI326 #2	UI325 #2	UI324 #2
93	UI323 #2	UI322 #2	UI321 #2	UI320 #2	UI319 #2	UI318 #2	UI317 #2	UI316 #2
94	UI315 #2	UI314 #2	UI313 #2	UI312 #2	UI311 #2	UI310 #2	UI309 #2	UI308 #2
95	UI307 #2	UI306 #2	UI305 #2	UI304 #2	UI303 #2	UI302 #2	UI301 #2	UI300 #2

		BMI-DI7							
		7	6	5	4	3	2	1	0
96	ERS	RRW	*SP	*ESP					*IT
97		EDT	MEM		D	J	H	S	
98	ZRN								
99	MLK	DLK	ABS		SBK		DRN	AFL	
100	KEY4	KEY3	KEY2	KEY1				ST	
101	RT	ROV2	ROV1	MP4	MP2	MP1		PRC	
102					HS3D	HS3C	HS3B	HS3A	
103	HS2D	HS2C	HS2B	HS2A	HS1D	HS1C	HS1B	HS1A	
104	*JV15	*JV14	*JV13	*JV12	*JV11	*JV10	*JV9	*JV8	
105	*JV7	*JV6	*JV5	*JV4	*JV3	*JV2	*JV1	*JV0	
106						DIST26	DIST25	DIST24	
107	DIST23	DIST22	DIST21	DIST20	DIST19	DIST18	DIST17	DIST16	
108	DIST15	DIST14	DIST13	DIST12	DIST11	DIST10	DIST9	DIST8	
109	DIST7	DIST6	DIST5	DIST4	DIST3	DIST2	DIST1	DIST0	
110							IHEAD2	IHEAD1	
111									



		BMI-DI8							
		7	6	5	4	3	2	1	0
112		EISTB	ERDRQ	EOREND	EIHEAD		EXSTP	EXRD	EXPUX
113		EIA7	EIA6	EIA5	EIA4	EIA3	EIA2	EIA1	EIA0
114		EID47	EID46	EID45	EID44	EID43	EID42	EID41	EID40
115		EID39	EID38	EID37	EID36	EID35	EID34	EID33	EID32
116		EID31	EID30	EID29	EID28	EID27	EID26	EID25	EID24
117		EID23	EID22	EID21	EID20	EID19	EID18	EID17	EID16
118		EID15	EID14	EID13	EID12	EID11	EID10	EID9	EID8
119		EID7	EID6	EID5	EID4	EID3	EID2	EID1	EID0
120									
121									
122									
123									
124									
125									
126									
127									

		BMI-DI9							
		7	6	5	4	3	2	1	0
128	DTCH1	*SVF1	*DEC1	*IT1	*-ED1	*+ED1	*-L1	*+L1	
129					MLK1	MI1	-J1	+J1	
130									
131									
132	DTCH2	*SVF2	*DEC2	*IT2	*-ED2	*+ED2	*-L2	*+L2	
133					MLK2	MI2	-J2	+J2	
134									
135									
136	DTCH3	*SVF3	*DEC3	*IT3	*-ED3	*+ED3	*-L3	*+L3	
137					MLK3	MI3	-J3	+J3	
138									
139									
140	DTCH4	*SVF4	*DEC4	*IT4	*-ED4	*+ED4	*-L4	*+L4	
141					MLK4	MI4	-J4	+J4	
142									
143									

		BMI-DI10							
		7	6	5	4	3	2	1	0
144		DTCH5	*SVF5	*DEC5	*IT5	*-ED5	*+ED5	*-L5	*+L5
145						MLK5	MI5	-J5	+J5
146									
147									

		BMI-DO1							
		7	6	5	4	3	2	1	0
200	CSS #1	THRD #1	RPO #1					IPEN #1	DEN #1
201							MBDT1 #1		
202	MBDT9 #1	MBDT8 #1	MBDT7 #1	MBDT6 #1	MBDT5 #1	MBDT4 #1	MBDT3 #1	MBDT2 #1	
203	TLCHB #1	TLCHA #1	ESEND #1						
204					BF #1	TF #1	SF #1	MF #1	
205	DM30 #1	DM02 #1	DM01 #1	DM00 #1					
206	R015 #1	R014 #1	R013 #1	R012 #1	R011 #1	R010 #1	R09 #1	R08 #1	
207	R07 #1	R06 #1	R05 #1	R04 #1	R03 #1	R02 #1	R01 #1	R00 #1	
208	AR15 #1	AR14 #1	AR13 #1	AR12 #1	AR11 #1	AR10 #1	AR69 #1	AR8 #1	
209	AR7 #1	AR6 #1	AR5 #1	AR4 #1	AR3 #1	AR2 #1	AR1 #1	AR0 #1	
210	MR15 #1	MR14 #1	MR13 #1	MR12 #1	MR11 #1	MR10 #1	MR9 #1	MR8 #1	
211	MR7 #1	MR6 #1	MR5 #1	MR4 #1	MR3 #1	MR2 #1	MR1 #1	MR0 #1	
212					SPAL8 #1	SPAL4 #1	SPAL2 #1	SPAL1 #1	
213									
214									
215									

BMI-DO2

	7	6	5	4	3	2	1	0
216	M31 #1	M30 #1	M29 #1	M28 #1	M27 #1	M26 #1	M25 #1	M24 #1
217	M23 #1	M22 #1	M21 #1	M20 #1	M19 #1	M18 #1	M17 #1	M16 #1
218	M15 #1	M14 #1	M13 #1	M12 #1	M11 #1	M10 #1	M9 #1	M8 #1
219	M7 #1	M6 #1	M5 #1	M4 #1	M3 #1	M2 #1	M1 #1	M0 #1
220	S31 #1	S30 #1	S29 #1	S28 #1	S27 #1	S26 #1	S25 #1	S24 #1
221	S23 #1	S22 #1	S21 #1	S20 #1	S19 #1	S18 #1	S17 #1	S16 #1
222	S15 #1	S14 #1	S13 #1	S12 #1	S11 #1	S10 #1	S9 #1	S8 #1
223	S7 #1	S6 #1	S5 #1	S4 #1	S3 #1	S2 #1	S1 #1	S0 #1
224	T31 #1	T30 #1	T29 #1	T28 #1	T27 #1	T26 #1	T25 #1	T24 #1
225	T23 #1	T22 #1	T21 #1	T20 #1	T19 #1	T18 #1	T17 #1	T16 #1
226	T15 #1	T14 #1	T13 #1	T12 #1	T11 #1	T10 #1	T9 #1	T8 #1
227	T7 #1	T6 #1	T5 #1	T4 #1	T3 #1	T2 #1	T1 #1	T0 #1
228	B31 #1	B30 #1	B29 #1	B28 #1	B27 #1	B26 #1	B25 #1	B24 #1
229	B23 #1	B22 #1	B21 #1	B20 #1	B19 #1	B18 #1	B17 #1	B16 #1
230	B15 #1	B14 #1	B13 #1	B12 #1	B11 #1	B10 #1	B9 #1	B8 #1
231	B7 #1	B6 #1	B5 #1	B4 #1	B3 #1	B2 #1	B1 #1	B0 #1

		BMI-DO3							
		7	6	5	4	3	2	1	0
232		UO031 #1	UO030 #1	UO029 #1	UO028 #1	UO027 #1	UO026 #1	UO025 #1	UO024 #1
233		UO023 #1	UO022 #1	UO021 #1	UO020 #1	UO019 #1	UO018 #1	UO017 #1	UO016 #1
234		UO015 #1	UO014 #1	UO013 #1	UO012 #1	UO011 #1	UO010 #1	UO009 #1	UO008 #1
235		UO007 #1	UO006 #1	UO005 #1	UO004 #1	UO003 #1	UO002 #1	UO001 #1	UO000 #1
236		UO131 #1	UO130 #1	UO129 #1	UO128 #1	UO127 #1	UO126 #1	UO125 #1	UO124 #1
237		UO123 #1	UO122 #1	UO121 #1	UO120 #1	UO119 #1	UO118 #1	UO117 #1	UO116 #1
238		UO115 #1	UO114 #1	UO113 #1	UO112 #1	UO111 #1	UO110 #1	UO109 #1	UO108 #1
239		UO107 #1	UO106 #1	UO105 #1	UO104 #1	UO103 #1	UO102 #1	UO101 #1	UO100 #1
240		UO231 #1	UO230 #1	UO229 #1	UO228 #1	UO227 #1	UO226 #1	UO225 #1	UO224 #1
241		UO223 #1	UO222 #1	UO221 #1	UO220 #1	UO219 #1	UO218 #1	UO217 #1	UO216 #1
242		UO215 #1	UO214 #1	UO213 #1	UO212 #1	UO211 #1	UO210 #1	UO209 #1	UO208 #1
243		UO207 #1	UO206 #1	UO205 #1	UO204 #1	UO203 #1	UO202 #1	UO201 #1	UO200 #1
244		UO331 #1	UO330 #1	UO329 #1	UO328 #1	UO327 #1	UO326 #1	UO325 #1	UO324 #1
245		UO323 #1	UO322 #1	UO321 #1	UO320 #1	UO319 #1	UO318 #1	UO317 #1	UO316 #1
246		UO315 #1	UO314 #1	UO313 #1	UO312 #1	UO311 #1	UO310 #1	UO309 #1	UO308 #1
247		UO307 #1	UO306 #1	UO305 #1	UO304 #1	UO303 #1	UO302 #1	UO301 #1	UO300 #1

BMI-DO4

	7	6	5	4	3	2	1	0
248	CSS #2	THRD #2	RPO #2				IPEN #2	DEN #2
249						MBDT1 #2		
250	MBDT9 #2	MBDT8 #2	MBDT7 #2	MBDT6 #2	MBDT5 #2	MBDT4 #2	MBDT3 #2	MBDT2 #2
251	TLCHB #2	TLCHA #2	ESEND #2					
252					BF #2	TF #2	SF #2	MF #2
253	DM30 #2	DM02 #2	DM01 #2	DM00 #2				
254	R015 #2	R014 #2	R013 #2	R012 #2	R011 #2	R010 #2	R09 #2	R08 #2
255	R07 #2	R06 #2	R05 #2	R04 #2	R03 #2	R02 #2	R01 #2	R00 #2
256	AR15 #2	AR14 #2	AR13 #2	AR12 #2	AR11 #2	AR10 #2	AR69 #2	AR8 #2
257	AR7 #2	AR6 #2	AR5 #2	AR4 #2	AR3 #2	AR2 #2	AR1 #2	AR0 #2
258	MR15 #2	MR14 #2	MR13 #2	MR12 #2	MR11 #2	MR10 #2	MR69 #2	MR8 #2
259	MR7 #2	MR6 #2	MR5 #2	MR4 #2	MR3 #2	MR2 #2	MR1 #2	MR0 #2
260					SPAL8 #2	SPAL4 #2	SPAL2 #2	SPAL1 #2
261								
262								
263								

## BMI-DO5

	7	6	5	4	3	2	1	0
264	M31 #2	M30 #2	M29 #2	M28 #2	M27 #2	M26 #2	M25 #2	M24 #2
265	M23 #2	M22 #2	M21 #2	M20 #2	M19 #2	M18 #2	M17 #2	M16 #2
266	M15 #2	M14 #2	M13 #2	M12 #2	M11 #2	M10 #2	M9 #2	M8 #2
267	M7 #2	M6 #2	M5 #2	M4 #2	M3 #2	M2 #2	M1 #2	M0 #2
268	S31 #2	S30 #2	S29 #2	S28 #2	S27 #2	S26 #2	S25 #2	S24 #2
269	S23 #2	S22 #2	S21 #2	S20 #2	S19 #2	S18 #2	S17 #2	S16 #2
270	S15 #2	S14 #2	S13 #2	S12 #2	S11 #2	S10 #2	S9 #2	S8 #2
271	S7 #2	S6 #2	S5 #2	S4 #2	S3 #2	S2 #2	S1 #2	S0 #2
272	T31 #2	T30 #2	T29 #2	T28 #2	T27 #2	T26 #2	T25 #2	T24 #2
273	T23 #2	T22 #2	T21 #2	T20 #2	T19 #2	T18 #2	T17 #2	T16 #2
274	T15 #2	T14 #2	T13 #2	T12 #2	T11 #2	T10 #2	T9 #2	T8 #2
275	T7 #2	T6 #2	T5 #2	T4 #2	T3 #2	T2 #2	T1 #2	T0 #2
276	B31 #2	B30 #2	B29 #2	B28 #2	B27 #2	B26 #2	B25 #2	B24 #2
277	B23 #2	B22 #2	B21 #2	B20 #2	B19 #2	B18 #2	B17 #2	B16 #2
278	B15 #2	B14 #2	B13 #2	B12 #2	B11 #2	B10 #2	B9 #2	B8 #2
279	B7 #2	B6 #2	B5 #2	B4 #2	B3 #2	B2 #2	B1 #2	B0 #2



BMI-DO6

	7	6	5	4	3	2	1	0
280	UO031 #2	UO030 #2	UO029 #2	UO028 #2	UO027 #2	UO026 #2	UO025 #2	UO024 #2
281	UO023 #2	UO022 #2	UO021 #2	UO020 #2	UO019 #2	UO018 #2	UO017 #2	UO016 #2
282	UO015 #2	UO014 #2	UO013 #2	UO012 #2	UO011 #2	UO010 #2	UO009 #2	UO008 #2
283	UO007 #2	UO006 #2	UO005 #2	UO004 #2	UO003 #2	UO002 #2	UO001 #2	UO000 #2
284	UO131 #2	UO130 #2	UO129 #2	UO128 #2	UO127 #2	UO126 #2	UO125 #2	UO124 #2
285	UO123 #2	UO122 #2	UO121 #2	UO120 #2	UO119 #2	UO118 #2	UO117 #2	UO116 #2
286	UO115 #2	UO114 #2	UO113 #2	UO112 #2	UO111 #2	UO110 #2	UO109 #2	UO108 #2
287	UO107 #2	UO106 #2	UO105 #2	UO104 #2	UO103 #2	UO102 #2	UO101 #2	UO100 #2
288	UO231 #2	UO230 #2	UO229 #2	UO228 #2	UO227 #2	UO226 #2	UO225 #2	UO224 #2
289	UO223 #2	UO222 #2	UO221 #2	UO220 #2	UO219 #2	UO218 #2	UO217 #2	UO216 #2
290	UO215 #2	UO214 #2	UO213 #2	UO212 #2	UO211 #2	UO210 #2	UO209 #2	UO208 #2
291	UO207 #2	UO206 #2	UO205 #2	UO204 #2	UO203 #2	UO202 #2	UO201 #2	UO200 #2
292	UO331 #2	UO330 #2	UO329 #2	UO328 #2	UO327 #2	UO326 #2	UO325 #2	UO324 #2
293	UO323 #2	UO322 #2	UO321 #2	UO320 #2	UO319 #2	UO318 #2	UO317 #2	UO316 #2
294	UO315 #2	UO314 #2	UO313 #2	UO312 #2	UO311 #2	UO310 #2	UO309 #2	UO308 #2
295	UO307 #2	UO306 #2	UO305 #2	UO304 #2	UO303 #2	UO302 #2	UO301 #2	UO300 #2

		BMI-DO7							
		7	6	5	4	3	2	1	0
296		MA	SA	OP	STL	SPL	RST	AL	RWD
297						INCH	DST		
298		MARN							
299			MEDT	MMEM		MD	MJ	MH	MS
300		MMLK	MDLK	MABS		MSBK		MDRN	MAFL
301			TLALM		SYALM	OTALM	OHALM	SVALM	PSALM
302					RPBSY				
303									
304									
305									
306									
307									
308									
309									
310								OHEAD2	OHEAD1
311									

		BMI-DO8							
		7	6	5	4	3	2	1	0
312	EOSTB			EIREND	EOHEAD				
313	EOA7	EOA6	EOA5	EOA4	EOA3	EOA2	EOA1	EOA0	
314	EOD47	EOD46	EOD45	EOD44	EOD43	EOD42	EOD41	EOD40	
315	EOD39	EOD38	EOD37	EOD36	EOD35	EOD34	EOD33	EOD32	
316	EOD31	EOD30	EOD29	EOD28	EOD27	EOD26	EOD25	EOD24	
317	EOD23	EOD22	EOD21	EOD20	EOD19	EOD18	EOD17	EOD16	
318	EOD15	EOD14	EOD13	EOD12	EOD11	EOD10	EOD9	EOD8	
319	EOD7	EOD6	EOD5	EOD4	EOD3	EOD2	EOD1	EOD0	
320					*REEL			TCHK	
321									
322									
323									
324									
325									
326									
327									

		BMI-DO9							
		7	6	5	4	3	2	1	0
328			INP1	ZP41	ZP31	MD1	MV1	ZP21	ZP1
329								MMLK1	MMI1
330									
331									
332			INP2	ZP42	ZP32	MD2	MV2	ZP22	ZP2
333								MMLK2	MMI2
334									
335									
336			INP3	ZP43	ZP33	MD3	MV3	ZP23	ZP3
337								MMLK3	MMI3
338									
339									
340			INP4	ZP44	ZP34	MD4	MV4	ZP24	ZP4
341								MMLK4	MMI4
342									
343									

BMI-DO10

	7	6	5	4	3	2	1	0
344		INP5	ZP45	ZP35	MD5	MV5	ZP25	ZP5
345							MMLK5	MMI5
346								
347								

**NOTE** Tool posts and BMI

15-TT controls turning machines which can turn one or two workpieces concurrently by operating two tool posts independently.

In other words, it is applicable to either turning machine (with 2 spindles and 2 tool posts) which can turn two workpieces concurrently by using two tool posts with two spindles, or turning machine (with 1 spindle and 2 tool posts) which can turn one workpiece concurrently by using two tool posts with one spindle.

The DI/DO signals of BMI can sorted when dividing them from the viewpoints of tool posts as described below.

## (a) DI/DO signals common to two tool posts

A signal having a certain function is provided to both first and second tool posts in common. The reset signal, emergency signal, and other signals that select basic operation modes of the control unit belong to this group. If a memory command operation mode is selected, for example, the memory command operation is selected for both first and second tool posts in common.

Both first and second tool posts are reset or urgently stopped concurrently by the reset or emergency stop signal.

## (b) DI/DO signals exclusively provided for individual tool posts

A signal having a certain signal is provided for the first tool post and second tool post independently. These signals are affixed with #1 or #2 at the end of their signal names.

Symbol #1 shows a signal exclusively provided for the first tool post, while symbol #2 shows a signal exclusively provided for the second tool post.

These signals are also subdivided into the following two groups.

## – Spindle control DI/DO

The following signals belong to this group.

- i. Command spindle speed signals RO0 – RO15
- ii. Maximum spindle speed signals MR0 – MR15
- iii. Actual spindle speed signals AR0 – MR15
- iv. Spindle motor command voltage signals RISGN, RI0 – RI12

In case of 2 spindles and 2 tool posts;

Individual tool post spindles are controlled by using spindle control DI/DO exclusively provided for tool posts.

In case of 1 spindle and 2 tool posts;

The spindle common to two tool posts is controlled by using spindle control DI/DO signals provided for the first tool post.

## – DI/DO other than those for spindle control

The feedrate override signal, auxiliary function code signals, stroke signal, etc. belong to this group.

The override of the cutting feedrate can be independently applied to individual tool posts, and auxiliary function code signal and strobe signal are sent to these tool posts independently of each other.

The DI/DO signals provided for each control axis may be said to belong to “DI/DO exclusively provided for individual tool posts” because that the axis controls either tool post only. However, these signals are not affixed with divided by tool posts, but divided by control axis numbers as viewed from the entire system.

In the 15-TT the following three groups are provided as the configuration of control axes.

	1st axis	2nd axis	3rd axis	4th axis	5th axis
1	1st tool post		2nd tool post		Not provided
	X1	Z1	X2	Z2	
2	1st tool post			2nd tool post	
	X1	Z1	Additional axis	X2	Z2
3	1st tool post		2nd tool post		Additional axis
	X1	Z1	X2	Z2	

Two axes are provided for each tool post (or, 4 axes in total) as the basic configuration, and one additional axis is provided for either tool post (5 axes in total) as the optional configuration.

(3) FS6M interface signal list

		F6M · MI-DI1							
		7	6	5	4	3	2	1	0
400	<u>DTCHX</u>	*SVFX	*DECX	*ITX	*-EDX	*+EDX	*-LX	*+LX	
401	HX				<u>MLKX</u>	MIX	-X	+X	
402	<u>DTCHY</u>	*SVFY	*DECY	*ITY	*-EDY	*+EDY	*-LY	*+LY	
403	HY				<u>MLKY</u>	MIY	-Y	+Y	
404	<u>DTCHZ</u>	*SVFZ	*DECZ	*ITZ	*-EDZ	*+EDZ	*-LZ	*+LZ	
405	HZ				ZNG	<u>MIZ</u>	-Z	+Z	
406	4NG	*SVF4	*DEC4	*IT4	*-ED4	*+ED4	*-L4	*+L4	
407	H4				<u>MLK4</u>	MI4	-4	+4	
408	MLK	DLK	ABS	OVC	SBK	BDT1	DRN	AFL	
409	ZRN	<u>BRN</u>	SRN	KEY	FID		FIN	ST	
410	ERS	RRW	*ST	*ESP	SKIP	UINT	SAR		
411	GST	SOR	*SSTP	GRB	GRA	SPC	SPB	SPA	
412	AGJ	EDT	MEN	T	D	J	H	S	
413	MP4	MP2	MP1	*FV16	*FV8	*FV4	*FV2	*FV1	

		F6M · MI-DI2							
		7	6	5	4	3	2	1	0
414		RT	ROV2	ROV1	*JV16	*JV8	*JV4	*JV2	*JV1
415		BDT9	BDT8	BDT7	BDT6	BDT5	BDT4	BDT3	BDT2
	(param.)	AGSTB	AG24	AG22	AG221	AG18	AG14	AG12	AG11
416		TLRST							
417		TLSKP	TL64	TL32	TL16	TL08	TL04	TL02	TL01
418				AGST	WN16	WN8	WN4	WN2	WN1
419		ESTB	EA6	EA5	EA4	EA3	EA2	EA1	EA0
420		ED15	ED14	ED13	ED12	ED11	ED10	ED9	ED8
421		ED7	ED6	ED5	ED4	ED3	ED2	ED1	ED0
422		UI15	UI14	UI13	UI12	UI11	UI10	UI9	UI8
423		UI7	UI6	UI5	UI4	UI3	UI2	UI1	UI0
424		SIND			R13I	R12I	R11I	R10I	R09I
425		R08I	R07I	R06I	R05I	R04I	R03I	R02I	R01I
426		5NG	*SVF5	*DEC5	*IT5	<u>*-ED5</u>	<u>*+ED5</u>	*-L5	*+L5
427		H5			<u>MLK5</u>	MI5	-5	+5	



F6M · MI-DO1

	7	6	5	4	3	2	1	0	
500	MA	SA	OP	STL	SPL	RST	AL	RWD	
501	<u>CSS</u>	<u>THRD</u>	<u>RPD</u>	<u>TAP</u>	<u>INCH</u>	DST	<u>IPEN</u>	DEN	
502	SSP	SRV	FMF	EF	BF	TF	SF	MF	
503	MMIY	SEY	ZP2Y	ZPY	MMIX	SEX	ZP2X	ZPX	
504	MMI4	SE4	ZP24	ZP4	<u>MMIZ</u>	SEZ	ZP2Z	ZPZ	
505	TLCHB	TLCHA	ESEND	EREND	MMI5	<u>SE5</u>	ZP25	ZP5	
506	M30	M02	M01	M00	M38	M34	M32	<u>M31</u>	
507	M28	M24	M22	M21	M18	M14	M12	M11	
508	T48	T44	T42	T41	T38	T34	T32	T31	
509	T28	T24	T22	T21	T18	T14	T12	T11	
510	B28	B24	B22	B21	B18	B14	B12	B11	(param.)
	S52	S51	S48	S44	S42	S41	GRB	GRA	S12BIT-A
	S48	S44	S42	S41	S38	S34	S32	S31	S12BIT-B
511	S38	S34	S32	S31	S28	S24	S22	S21	(param.)
	S28	S24	S22	S21	S18	S14	S12	S11	S12BIT-A
	S28	S24	S22	S21	S18	S14	S12	S11	S12BIT-B

		F6M · MI-DO2								
		7	6	5	4	3	2	1	0	
512		B18	B14	B12	B11	R12	R11	R10	R09	(param.)
		B38	S34	S32	S31	R12	R11	R10	R09	S12BIT-A
		S58	S54	S52	S51	R12	R11	R10	R09	S12BIT-B
513		R08	R07	R06	R05	R04	R03	R02	R01	
514		UO15	UO14	UO13	UO12	UO11	UO10	UO09	UO08	
515		UO7	UO6	UO5	UO4	UO3	UO2	UO1	UO0	
516		MMLK	MDLK	MABS	MZNG	MSBK	MBDT1	MDRN	MAFL	
517		MBDT9	MBDT8	MBDT7	MBDT6	MBDT5	MBDT4	MBDT3	MBDT2	
518								BCLP	BUCL	

\*The underlined signals are added to 6M

DI DTCHX, Y, Z : detach axis  
 MLKX, Y, 4, 5 : machine lock axis  
 MIZ : mirror image  
 \* +ED4, 5, \* -ED4, 5 : external deceleration  
 BRN : block return  
 DO CSS : constant cutting speed mode  
 THRD : threading mode  
 TAP : tapping mode  
 INCH : inch input mode  
 IPEN : interpolation end  
 MMIZ : mirror imaged  
 SE5 : axis select

\*The following signals are not provided for 6T, but exclusively for 6M.

DI FID, angular jogs (AGJ, AGSTB, AGI1AAG24, AGST), OVRCD, \*BECLP, \*BEUCL  
 DO SSP, SRV, FMF, EF, BF, M 3rd, S 5th, T 3rd-4th, B 1st-3rd, MZNG, BCLP, BUCL

\*The following signals are defined in 6T, but not included in above.

DI STLK, XAE, ZAE, PRC, SMZ, CDZ, \*SECLP, \*SEUCL, SPSTP  
 DO SCLP, SUCL

(4) FS6T interface signal list

		F6T·MI-DI1							
		7	6	5	4	3	2	1	0
400	<u>DTCHX</u>	*SVFX	*DECX	*ITX	<u>*-EDX</u>	<u>*+EDX</u>	*-LX	*+LX	
401	HX				<u>MLKX</u>	MIX	-X	+X	
402	<u>DTCHZ</u>	*SVFZ	*DECZ	*ITZ	<u>*-EDZ</u>	<u>*+EDZ</u>	*-LZ	*+LZ	
403	HZ				<u>MLKZ</u>	<u>MIZ</u>	-Z	+Z	
404	<u>DTCH3</u>	*SVF3	*DEC3	*IT3	<u>*-ED3</u>	<u>*+ED3</u>	*-L3	*+L3	
405	H3				<u>MLK3</u>	MI3	-3	+3	
406	<u>DTCH4</u>	*SVF4	*DEC4	*IT4	<u>*-ED4</u>	<u>*+ED4</u>	*-L4	*+L4	
407	H4				<u>MLK4</u>	<u>MI4</u>	-4	+4	
408	MLK	DLK	ABS	OVC	SBK	BDT1	DRN	AFL	
409	ZRN	<u>BRN</u>	SRN	KEY			FIN	ST	
410	ERS	RRW	*ST	*ESP	SKIP	UINT	SAR	STLK	
411	GST	SOR	*SSTP			SPC	SPB	SPA	
412		EDT	MEN	T	D	J	HS		
413	MP4	MP2	MP1		GR4	GR3	GR2	GR1	

		F6T·MI-DI2							
		7	6	5	4	3	2	1	0
414	RT	ROV2	ROV1	*OV16	*OV8	*OV4	*OV2	*OV1	
415	BDT9	BDT8	BDT7	BDT6	BDT5	BDT4	BDT3	BDT2	
416	TLRST		PRC		ZAE	XAE	SMZ	CDZ	
417	TLSKP				TL08	TL04	TL02	TL01	
418				WN16	WN8	WN4	WN2	WN1	
419	ESTB	EA6	EA5	EA4	EA3	EA2	EA1	EA0	
420	ED15	ED14	ED13	ED12	ED11	ED10	ED9	ED8	
421	ED7	ED6	ED5	ED4	ED3	ED2	ED1	ED0	
422	UI15	UI14	UI13	UI12	UI11	UI10	UI9	UI8	
423	UI7	UI6	UI5	UI4	UI3	UI2	UI1	UI0	
424	SIND			R13I	R12I	R11I	R10I	R09I	
425	R08I	R07I	R06I	R05I	R04I	R03I	R02I	R01I	
426					*SECLP	*SEUCL		SPSTP	
427									

F6T·MI-DO1

	7	6	5	4	3	2	1	0
500	MA	SA	OP	STL	SPL	RST	AL	RWD
501	<u>CSS</u>	<u>THRD</u>	<u>RPD</u>	<u>TAP</u>	<u>INCH</u>	DST	<u>IPEN</u>	DEN
502						TF	SF	MF
503	<u>MMIZ</u>	<u>SEZ</u>	ZP2Z	ZPZ	<u>MMIX</u>	<u>SEX</u>	ZP2X	ZPX
504	<u>MMI4</u>	<u>SE4</u>	ZP24	ZP4	<u>MMI3</u>	<u>SE3</u>	ZP23	ZP3
505	TLCHB	TLCHA	ESEND	EREND				
506	M30	M02	M01	M00				
507	M28	M24	M22	M21	M18	M14	M12	M11
508								
509	T28	T24	T22	T21	T18	T14	T12	T11
510	S48	S44	S42	S41	S38	S34	S32	S31
511	S28	S24	S22	S21	S18	S14	S12	S11
512					R12	R11	R10	R09
513	R08	R07	R06	R05	R04	R03	R02	R01
514	UO15	UO14	UO13	UO12	UO11	UO10	UO9	UO8

## F6T: MI-DO2

515	UO7	UO6	UO5	UO4	UO3	UO2	UO1	UO0
516	MMLK	MDLK	MABS	MZNG	MSBK	MBDT1	MDRN	MAFL
517	MBDT9	MBDT8	MBDT7	MBDT6	MBDT5	MBDT4	MBDT3	MBDT2
518							SCLP	SUCL

\*The underlined signals are added to 6T.

DI DTCHX, Z, 3, 4 : detach axis

MLKX, Z, 3, 4 : machine lock axis

MIZ, 3, 4 : mirror image

\* +EDX, Z, 3, 4: external deceleration

\* -EDX, Z, 3, 4

BRN : block return

DO CSS : constant cutting speed mode

THRD : threading mode

TAP : tapping mode

INCH : inch input mode

IPEN : interpolation end

MMIX, Z, 3, 4 : mirror imaged

SEX, Z, 3, 4 : axis select

\*The following signals are not provided for 6M, but exclusively for 6T.

DI STLK, XAE, ZAE, PRC, SMZ, CDZ, \*SECCP, \*SEUCL, SPSTP

DO SCLP, SUCL

\*The following signals are defined in 6M, but not included in above.

DI F1D, angular jogs (AGJ, AGSTB, AG11 A AG24, AGST), OVRCD, \*BECLP, \*BEUCL

DO SSP, SRV, FMF, EF, BF, M 3rd, S 5th, T 3rd-4th, B 1st-3rd, MZNG, BCLP, BUDL

(5) FS3M interface signal list

		F3M-MI-DI1							
		7	6	5	4	3	2	1	0
400	<u>DTCHX</u>	*SVFX	*DECX	*ITX					
401	HX/ROV1				<u>MLKX</u>	<u>MIX</u>	-X	+X	
402	<u>DTCHY</u>	*SVFY	*DECY	*ITY					
403	HY/ROV2				<u>MLKY</u>	<u>MIY</u>	-Y	+Y	
404	<u>DTCHZ</u>	*SVFZ	*DECZ	*ITZ					
405	HZ/DRN				ZNG	<u>MIZ</u>	-Z	+Z	
406									
407									
408	MLK	DLK	ABS	<u>OVC</u>	SBK	BDT		AFL	
409	ZRN	<u>BRN</u>		KEY			FIN	ST	
410	ERS		*ST	*ESP	SKIP		SAR	*ILK	
411		SOR	*SSTP			SPC	SPB	SPA	
412						MD4	MD2	MD1	
413		MP2	MP1						

**NOTE** The additional underlined signals are newer than usual 3M.

		F3M-MI-DI2							
		7	6	5	4	3	2	1	0
414	RT					*OV8	*OV4	*OV2	*OV1
415									
416									
417									
418						PN8	PN4	PN2	PN1
419	ESTB	EA6	EA5	EA4	EA3	EA2	EA1	EA0	
420	ED15	ED14	ED13	ED12	ED11	ED10	ED9	ED8	
421	ED7	ED6	ED5	ED4	ED3	ED2	ED1	ED0	
422	UI15	UI14	UI13	UI12	UI11	UI10	UI9	UI8	
423	UI7	UI6	UI5	UI4	UI3	UI2	UI1	UI0	
424	SIND	SSIN	SGN			R12I	R11I	R10I	R09I
425	R08I	R07I	R06I	R05I	R04I	R03I	R02I	R01I	



		F3M-MI-DO1							
		7	6	5	4	3	2	1	0
500		MA	SA	OP	STL	SPL	RST	AL	
501		<u>CSS</u>	<u>THRD</u>	<u>RPD</u>	<u>TAP</u>	<u>INCH</u>	DST	<u>IPEN</u>	DEN
502						BF	TF	SF	MF
503				ZP2Y	ZPY			ZP2X	ZPX
504								ZP2Z	ZPZ
									EF
	(param.)								
505					EREND				
506		<u>M30</u>	<u>M02</u>	<u>M01</u>	<u>M00</u>				
507		M28	M24	M22	M21	M18	M14	M12	M11
508									
509		T28	T24	T22	T21	T18	T14	T12	T11
510		S28	S24	S22	S21	S18	S14	S12	S11
							HIG	MDG	LWG
	(param.)								
511		B38	B34	B32	B31	B28	B24	B22	B21
512		B18	B14	B12	B11				

		F3M-MI-DO2							
		7	6	5	4	3	2	1	0
513									
514		UO15	UO14	UO13	UO12	UO11	UO10	UO9	UO8
515		UO7	UO6	UO5	UO4	UO3	UO2	UO1	UO0
516									
517									
518					ENB				

(6) FS3T interface signal list

		F3T.MI-DI1							
		7	6	5	4	3	2	1	0
400	<u>DTCHX</u>	*SVFX	*DECX						
401	HX/ROV1				<u>MLKX</u>	MIX	-X	+X	
402	<u>DTCHZ</u>	*SVFZ	*DECZ						*+LZ
403	HZ/ROV2				<u>MLKZ</u>	<u>MIZ</u>	-Z	+Z	
404									
405									
406									
407									
408	MLK	<u>DLK</u>	ABS	<u>OVC</u>	SBK	BDT	DRN	AFL	
409	ZRN	<u>BRN</u>		KEY			FIN	ST	
410	ERS		*SP	*ESP	SKIP		SAR	STLK	
411		SOR	*SSTP			SPC	SPB	SPA	
412						MD4	MD2	MD1	
413		MP2	MP1				GR2	GR1	

**NOTE** The additional underlined signals are newer than usual 3T.

		F3T·MI-DI2							
		7	6	5	4	3	2	1	0
414	RT					*OV8	*OV4	*OV2	*OV1
415									
416			PRC			ZAE	XAE	SWZ	CDZ
417									
418						PN8	PN4	PN2	PN1
419	ESTB	EA6	EA5	EA4	EA3	EA2	EA1	EA0	
420	ED15	ED14	ED13	ED12	ED11	ED10	ED9	ED8	
421	ED7	ED6	ED5	ED4	ED3	ED2	ED1	ED0	
422	UI15	UI14	UI13	UI12	UI11	UI10	UI9	UI8	
423	UI7	UI6	UI5	UI4	UI3	UI2	UI1	UI0	
424	SIND	SSIN	SGN			R12I	R11I	R10I	R09I
425	R08I	R07I	R06I	R05I	R04I	R03I	R02I	R01I	

F3T-MI-DO1

	7	6	5	4	3	2	1	0
500	MA	SA	OP	STL	SPL	RST	AL	
501	<u>CSS</u>	<u>THRD</u>	<u>RPD</u>	<u>TAP</u>	<u>INCH</u>	DST	<u>IPEN</u>	DEN
502						TF	SF	MF
503			ZP2Z	ZPZ			ZP2X	ZPX
504								
505				EREND				
506								
507	M28	M24	M22	M21	M18	M14	M12	M11
508								
509	T28	T24	T22	T21	T18	T14	T12	T11
510								
511	S28	S24	S22	S21	S18	S14	S12	S11
512					R12	R11	R10	R09
513	R08	R07	R06	R05	R04	R03	R02	R01
514	UO15	UO14	UO13	UO12	UO11	UO10	UO9	UO8

		F3T-MI-DO2							
		7	6	5	4	3	2	1	0
515		UO7	UO6	UO5	UO4	UO3	UO2	UO1	UO0
516									
517									
518					ENB				

**A**

Action to be taken when an error code is displayed, 18

Address at which an Error Occurred (ERROR ADRS), 182

Adjusting a Flat Display, 87

---

**B**

Block Diagram for the CNC Control Unit, 6

---

**C**

Checking the ground connection, 46

Configuration of additional axis (ADAX) board, 159

Configuration of the Axis CPU Board (ACPU), 143

Configuration of the CNC Control Equipment, 3

Configuration of the CNC control unit, 3

Configuration of the CPU Board (MAIN-B), 119

Configuration of the CRT/MDI unit, 5

Configuration of the High-Speed Multiaxis Main CPU Board (MAX MAIN-A), 130

Configuration of the Main CPU Board (MAIN-A), 123

Configuration of the Multiaxis Buffer Board, 146

Configuration of the option 1 board, 161

Configuration of the PMC-NA Board, 134

Configuration of the PMC-NA Board with or without the Conversational Function, 137

Configuration of the PMC-NB Board with or without the Conversational Function, 140

Configuration of the printed circuit boards in the CNC control unit, 5

CONFIGURATION OF THE PRINTED CIRCUIT BOARDS IN THE CONTROL UNIT, 117

Configuration of the RISC Board, 148

Configuration of the Standard Multiaxis Sub-CPU Board (MAX SUB-B), 153

Configuration of the Sub. CPU board (SUB-A), 150

Configuration of the Upgraded Main CPU Board (MAIN-C), 127

Configuration of the Upgraded Sub-CPU Board (SUB-C), 156

Confirmation of Connection between CNC Control Unit and Servo, 70

Confirmation of Power Supply Connection, 47

Confirming CNC Control Unit Connection, 48

Confirming Power Source Voltage, 44

CONFIRMING POWER SOURCE VOLTAGE AND POWER CONNECTION, 44

Confirming the Connection between the CNC Control Unit and Spindle Motor, 74

Confirming the Connection between the NC Control Unit and I/O devices, 77

Connection of AC servo power transformer, 47

Connection of FANUC I/O Link, 51

Connection of I/O Unit-MODEL A, 58

Connection of operator's panel connection unit, 63

Connection of tape reader with reels, 82

Connection of tape reader without reels, 81

Connection with Connection unit, 62

CPU Status (CPU STATUS), 182

CRT display interface, 66

---

**D**

Diagnosis function for the interface with machine tools, 30

DISPLAYING AND SPECIFYING PARAMETERS, 88

Displaying Conditions Using the Self-diagnosis Function, 30

Displaying Parameters, 88

Displaying parameters other than those related to pitch error compensation, 88

Displaying parameters related to pitch error compensation, 88

Displaying System Configurations, 39

Displaying the System Log Screen, 184

---

**F**

FANUC Cassette connection, 80

Formats of parameter tapes, 89

Function to display the CNC internal status, 31

---

**H**

Hardware Status (HARD INFORMATION), 183

---

## HOW TO REPLACE FUSES, PRINTED CIRCUIT BOARDS, AND OTHER UNITS, 165

- How to Replace the Batteries, 169
  - How to Replace the Card Cage in the Control Unit, 172
  - How to Replace the CRT Display, 174
  - How to Replace the Fan Motor, 171
  - How to Replace the Fuses in the Power Supply Unit, 165
  - How to Replace the MDI Keyboard, 173
  - How to Replace the Modules, 168
  - How to Replace the Power Supply Unit, 166
  - How to Replace the Printed Circuit Boards in the Control Unit, 167
- 

## I

- Input/Output of CNC Data, 111
  - Inputting and outputting PMC data (when the reader/punch interface is used), 107
  - Inputting CNC parameters, 115
  - Inputting offset data, 116
  - Inputting part programs, 115
- 

## K

- Keyboard interface, 67
- 

## L

- LCD-PDP display interface, 67
  - Lighting of alarm LEDs on PCBs, 22
  - List of the Printed Circuit Boards and Units of Series 15B, 9
- 

## M

- Main Spare Parts, 16
  - MAINTENANCE EQUIPMENT, 16
  - Manual pulse generator interface, 68
  - Master CPU of the Bus (BUS MASTER), 182
- 

## O

- Optical fiber cable, 54
  - Outputting all parameters, 92
  - Outputting CNC parameters, 115
  - Outputting offset data, 115
  - Outputting Parameters, 92
  - Outputting parameters for pitch error compensation, 92
  - Outputting part programs, 115
  - Outputting the parameters excluding those related to pitch error compensation, 92
- 

## P

- Parameters, 93
  - Portable tape reader connection, 79
  - Power supply in the control unit, 44
  - Power Unit Configuration, 117
  - PPR connection, 78
  - Problems and Corrective Measures, 17
  - Procedure for replacing the dry cell for the absolute pulse coder, 170
  - Procedure for replacing the dry cell for the control unit (memory back-up), 169
  - Procedures for Troubleshooting, 17
  - Program Counter (PROG COUNT), 182
- 

## R

- Remote buffer interface (RS-232-C), 68
  - Remote buffer interface (RS-422), 69
  - RS-232-C serial port, 77
- 

## S

- Series 15-MB total connection diagram (In case of serial spindle), 48
- Servo amplifier, 46
- Setting and displaying counter data, 104
- Setting and displaying data in the data table, 105
- Setting and displaying keep relay data and data for controlling the retained memory, 104
- Setting and Displaying PMC Data (using the PCPRM soft key), 103
- Setting and displaying timer data, 103
- Setting the parameters necessary for input/output, 111



**SIGNAL INTERFACE LIST BETWEEN CNC  
AND PMC, 185**

Software series and edition, 179

Software Status (SOFT INFORMATION), 183

Specifying Parameters, 89

Specifying parameters through the MDI, 91

Specifying parameters through the reader/punch  
interface, 91

Startup and Adjustment Procedures, 83

**STARTUP AND ADJUSTMENTS, 83**

System alarm, 17

System alarm screen, 179

**SYSTEM ALARMS, 177**

System alarms (SYSTEM ALARM FACTOR),  
180

System Alarms When the CNC System Is Turned  
On, 177

System Alarms While the CNC System Is  
Operating, 179

---

**T**

Tap change of control power transformer, 47

The input/output unit of the reader/punch  
interface do not operate correctly., 26

The machine cannot be operated by the manual  
pulse generator., 24

The machine cannot be operated in the automatic  
mode., 25

The machine cannot be operated in the jog mode.,  
23

The machine does not return to the correct  
reference position., 27

The spindle cannot be operated in the  
synchronous feed mode., 24

**TROUBLESHOOTING AND ACTION TO BE  
TAKEN, 17**

---

**U**

User Number for the Active Task (ACT TASK),  
182

Revision Record

FANUC Series 15-MODEL B/Series 150-MODEL B MAINTENANCE MANUAL (B-62075E)

03	Feb., '95	<p>The following products are added</p> <ul style="list-style-type: none"> <li>• FANUC Series 150-TB</li> <li>• FANUC Series 150-TTB</li> <li>• FANUC Series 150-MB</li> </ul>				
02	Aug., '94	<p>The explanation of various printed circuit boards was added to the paragraph of the control unit printed circuit boards.</p>				
01	Jan., '93	_____				
Edition	Date	Contents	Edition	Date	Contents	

- *No part of this manual may be reproduced in any form.*
- *All specifications and designs are subject to change without notice.*