

DR21R

Direct Replacement Encoder for Select Renco RCH20D and RHS25D Models*

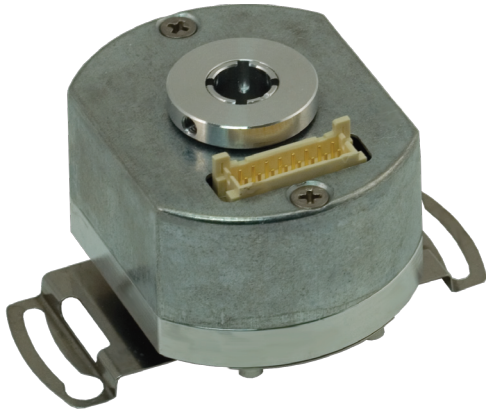

The Accu-Coder DR21R is a highly customized, Direct Replacement Encoder with a unique, OEM-specific ABS stepped voltage output channel. DR21R configurations replace select Renco RCH20D and RHS25D models* originally installed on legacy F, H, W, N and HSM servo motor models. An exact mechanical and electrical cross-reference for these obsolete Renco configurations, the DR21R also incorporates EPC's advanced Opto-ASIC sensing technology, providing superior thermal stability and signal reliability. The DR21R is available in 4 to 6 working days, with a Next Day Expedite option available, and it is fully backed by EPC's industry best 3-year warranty.

*These models have been discontinued by the manufacturer, and are increasingly difficult to find and costly to replace.

The Accu-Coder™ DR21R Features:

- Replaces select RCH20D and RHS25D Renco models
- Line Driver output with ABS stepped voltage output
- Quadrature with index
- 5 VDC Input Voltage
- End mount 16-pin header connection
- Operating temperature up to 100°C

DR21R Ordering Information

RENCO MODEL NUMBER	EPC DIRECT REPLACEMENT	CPR	POLE COUNT	BORE SIZE	MOUNT BC	INDEX GATING	MOTOR SERIES
RCH20D-2000/4-1/2-5/0-LD/VC-7-M6-S	DR21R-01	2000	8	0.500"	3.125"	A	F
RHS25D-P3-2000/4-1/2-5-CA6-LD-MS-CM-S	DR21R-01†	2000	8	0.500"	3.125"	A	F
RCH20D-5000/4-1/2-5/0-LD/VC-1-M6-S	DR21R-02	5000	8	0.500"	3.125"	A & B	F
RCH20D-2000/2-8MM-5/0-LD/VC-1-M6-S	DR21R-03	2000	4	8 mm	2.375"	A & B	H, HSM2
RCH20D-2000/3-8MM-5/0-LD/VC-1-M6-S	DR21R-04	2000	6	8 mm	2.375"	A & B	H, HSM3, HSM4
RCH20D-2000/4-1/2-5/0-LD/VC-1-M6-S	DR21R-05	2000	8	0.500"	2.375"	A & B	H, HSM6, HSM8
RCH20D-5000/3-8MM-5/0-LD/VC-1-M6-S	DR21R-06	5000	6	8 mm	2.375"	A & B	H
RCH20D-2000/3-1/2-5/0-LD/VC-7-M6-S	DR21R-07	2000	6	0.500"	2.375"	A	W
RHS25D-P3-2000/3-1/2-5-CA6-LD-MS-CM-S	DR21R-07†	2000	6	0.500"	2.375"	A	W
RCH20D-2000/2-12MM-5/0-LD/VC-1-M4-S <i>Includes hub shaft cover.</i>	DR21R-08	2000	4	12 mm	1.812"	A & B	N

†Requires accessory cable 080499-01

Accessory Options

Part No.	Description
080499-01	6" Mating Cable

Don't see the exact encoder you need replaced?

Call **1-800-366-5412** to speak to a Customer Service Representative who will be happy to cross-reference any model you need replaced with an EPC encoder.



NOTE: The DR21R ABS Encoder requires installation by a qualified technician.

ACCU  **CODER**™
by Encoder Products Company

DR21R

Direct Replacement Encoder for Select Renco RCH20D and RHS25D Models

Model DR21R Specifications

Electrical

- Input Voltage.....5 VDC
- Input Current.....150 mA max with no output load
- Output Format.....Incremental – Two square waves in quadrature with channel A leading B for clockwise shaft rotation (as viewed from the mounting face), commutation and ABS stepped voltage.
See *Waveform Diagrams*.
- Output Types.....TTL Line Driver – 20 mA max per channel (Meets RS 422 at 5 VDC supply)
- Index.....Once per revolution. See *Waveform Diagrams*.
- Max. Frequency.....300 KHz
- Noise Immunity.....Tested to BS EN61000-6-2; BS EN50081-2; BS EN61000-4-2; BS EN61000-4-3; BS EN61000-4-6, BS EN55011
- Symmetry.....180° (±18°) electrical
- Quad. Phasing.....90° (±22.5°) electrical
- Min. Edge Sep.....67.5° electrical
- Accuracy.....Within 0.01° mechanical from one cycle to any other cycle, or 0.6 arc minutes.
- Commutation.....Up to 8 pole
- Comm. Accuracy.....1° mechanical

Mechanical

- Max Shaft Speed.....6000 RPM
- Bore Size.....0.500" or 8 mm
- Bore Tolerance.....-0.0000" / +0.0006"
- User Shaft Tolerances
 - Radial Runout.....0.007" max
 - Axial Endplay.....±0.030" max
- Starting Torque.....0.50 oz-in
- Moment of Inertia.....3.9 X 10⁻⁴ oz-in-sec²
- Max Acceleration.....1 X 10⁵ rad/sec²
- Electrical Conn.....16-pin End Mount Header
- Housing.....All Metal Aluminum and Zinc Alloy
- Mounting.....1.182", 2.375" or 3.125" Flex-Mount
- Weight.....3.5 oz typical

Environmental

- Operating Temp.....0° to 100°C
- Storage Temp.....-30° to 110° C
- Humidity.....5% – 90% RH non-condensing
- Vibration.....10 g @ 58 to 500 Hz
- Shock.....50 g @ 11 ms duration
- Sealing.....IP50

DR21R Dimensions

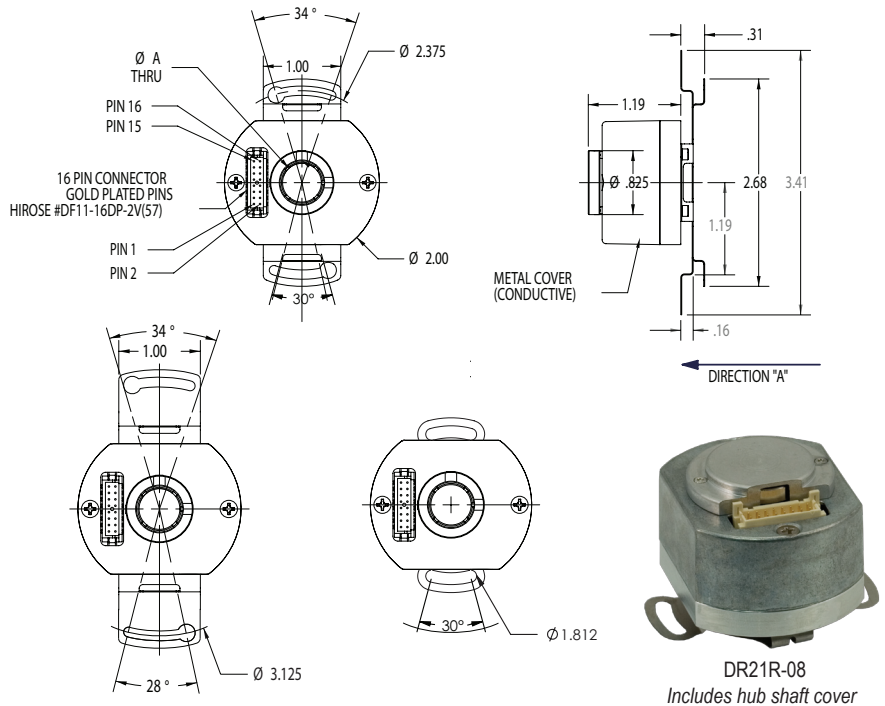

DR21R Waveform Diagram

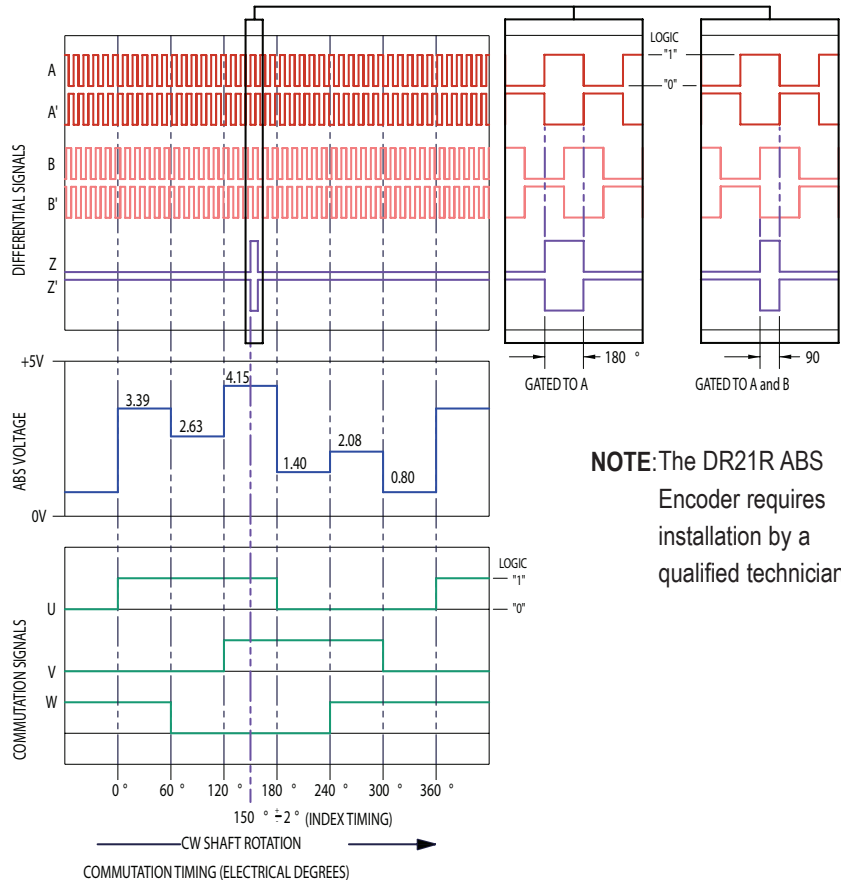

DR21R Wiring Table

Pin	Function	Mating Cable Wire Color
1	+5 VDC	White
2	U	Violet
3	COM	Black
4	V	Gray
5	A	Brown
6	W	Red/Black
7	A'	Yellow
8	ABS	Yellow/Black
9	B	Red
10	---	N/C
11	B'	Green
12	---	N/C
13	Z (INDEX)	Orange
14	---	N/C
15	Z' (INDEX)	Blue
16*	CASE GROUND	N/C

* A 0.10 uF capacitor is connected from common (COM) to case ground internal to encoder.