

be in motion be in motion

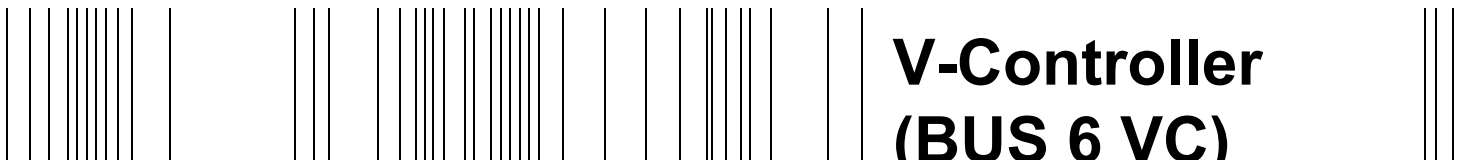

**V-Controller
(BUS 6 VC)**

SW 4.XX + 14.XX

Manual

E

5.95036.17



BAUMÜLLER

Title	Manual
Product	V-Controller (BUS 6 VC)
Version	5.95036.17
Copyright	<p>These operating instructions may be copied by the owner in any quantity but only for internal use. For other purposes these operating instructions and extracts thereof must not be copied or reproduced.</p> <p>Use and disclosure of information contained in these operating instructions are not permitted.</p> <p>Designations and company marks contained in these operating instructions may be brand names, the use of which by third parties for their own purposes may violate the rights of the holders.</p>
Obligatory	<p>These operating instructions are part of the equipment/machine. These operating instructions must be available to the operator at all times and must be in a legible condition. If the equipment/machine is sold or moved to a different location these operating instructions must be passed on by the owner together with the equipment/machine.</p> <p>After any sale of the equipment/machine this original and all copies must be handed over to the buyer. After disposal or any other end of use this original and all copies must be destroyed.</p> <p>When the present operating instructions are handed over, corresponding sets of operating instructions of a previous version are automatically invalidated. Please notice that specifications/data/information are current values according to the printing date. These statements are not legally binding according to the measurement, computation and calculations.</p> <p>Baumüller Nürnberg GmbH reserves the right, in developing its products further, to change the technical specifications and the handling of the products concerned without prior notice.</p> <p>No liability can be accepted concerning the correctness of the operating instructions unless otherwise specified in the General Conditions of Sale and Delivery.</p>
Manufacturer	<p>Baumüller Nürnberg GmbH Ostendstr. 80 - 90 D-90482 Nürnberg Germany Tel. +49 9 11 54 32 - 0 Fax: +49 9 11 54 32 - 1 30 www.baumueller.de</p>

TABLE OF CONTENTS

1 Safety Information 7

2 Technical Data 9

 2.1 General 9

 2.2 Electrical Data 11

 2.3 Type Code 12

3 Transportation, Unpacking 15

4 Assembly 17

 4.1 Dimensions 17

 4.2 Assembly Note 18

5 Installation 19

 5.1 Danger Information 19

 5.2 Checks Prior to Installation 20

 5.3 Display 21

 5.3.1 Seven-segment Display 21

 5.3.2 LED Display Element 22

 5.4 Terminal Diagram 23

 5.5 Connection of the Function Inputs 24

 5.6 Connector Pin Assignment 25

 5.7 Connection Cables 31

 5.7.1 Connection Cable Encoder Types A, B, C and E 31

 5.7.2 Serial Connection Cable for PC 32

 5.7.3 Connection Cable RS485 34

 5.7.4 Connection of Leading Axis and Following Axis 35

 5.8 Accessories 35

6 Commissioning 37

 6.1 Danger Information 37

 6.2 Initial Commissioning of V-Controller 40

 6.2.1 Hardware requirements 40

 6.2.2 Installation WinBAS 41

 6.2.3 Guided commissioning 44

 6.2.4 Speed control by means of analog input 1 51

 6.3 Locating Position Reference Point Setting 57

 6.4 Commands to Start the Drive 58

 6.5 Commands to Stop the Drive 60

Table of Contents

7	Parameters	63
7.1	Function Diagrams	63
7.2	Power Supply	67
7.3	Power Unit	69
7.4	Overload Monitoring of Power Unit	75
7.5	Pulse Width Modulation	78
7.6	Motor Model	80
7.7	Motor Overload Monitoring	86
7.8	Motor Temperature Monitoring	89
7.9	Field Angle Calculation	92
7.10	Encoder Manager	96
7.11	Touch probe cycle	102
7.12	Incremental Encoder Emulation	107
7.13	Evaluation Encoder 1 and Encoder 2	108
7.14	Field angle monitoring and Sin ² Cos ² -monitoring	118
7.15	Current Controller	120
7.16	Speed Controller	126
7.17	Torque Monitoring	129
7.18	Position Controller	133
7.19	Drive Manager	140
7.20	Data Set Management	158
7.21	Operation System	164
7.22	Ramp Function Generator	167
7.23	Set Value Generator	171
7.24	Motor Potentiometer	173
7.25	Analog Inputs	177
7.26	Analog Outputs	182
7.27	LED Display	184
7.28	Digital Inputs	187
7.29	Digital Outputs	191
7.30	External Digital Input	194
7.31	External Digital Outputs	197
7.32	Function module "freely configurable statusword GP State"	200
7.33	Service Interface	203
7.34	Link to USS® Protocol	208
7.35	BAPS Communication	222
7.36	Additional Parameter	224
7.37	Objekt list	225
8	Maintenance	227
8.1	Maintenance Information	227
8.2	Error Messages	228
8.3	Disposal	236
9	Appendix	237
9.1	Manufacturer Declaration	237
9.2	General Conditions of Sale and Delivery	238
9.3	Parameter List	241
9.4	Index	251

ABBREVIATIONS

AC	Alternating current	PD	Parameter description
ADR	Address byte	PI	Parameter identification
AI	Function module analog inputs	PIV	Parameter identification value
AM	Asynchronous motor	PN	Parameter no.
AO	Function module analog outputs	PS	Function module power supply
BAPS	Baumüller parallel interface	PV	Parameter value
BASS	Baumüller serial interface	PWM	Function module pulse width modulation
BCC	Block check character	RFG	Function module ramp function generator
BOF	Begin of file	SM	Synchronous motor
BSA	Reference potential analog	SPM	Space phasor modulation
BSD	Reference potential digital	STX	Start of text
BUM	Type of Baumüller converter	SV	Function module service interface
CE	Controller enabling	SVG	Function module set value generator
CPU	Central Processing Unit	TM	Temperature motor
CT	Function module coordinate transformation	USS®	Trademark Siemens, universal serial interface
DA	Digital/analog	ZK	Intermediate circuit
DC	Direct current		
DI	Function module digital inputs		
DSM	Function module data set management		
EOF	End of file		
Ext	Function module current monitoring		
MC	Main conductor		
MCO	Main conductor on		
MOE	Enable main conductor		
I	Function module current control		
I2t	Function module overload monitoring		
Inc	Unit of position counter		
IND	Index		
Ink	No. of graduation marks		
J/RI	Job / reply identification		
LED	Light-emitting diode		
LGE	Telegram length		
LT	Function module power unit		
M	Function module drive manager		
MM	Function module motor model		
Mot	Function module field angle calculation		
MT	Function module motor temperature		
N	Function module speed controller		
OS	Function module operation system		
P	Parameter number		
P	Function module position controller		
Para.	Paragraph		
PD	Process data		

1 SAFETY INFORMATION

General Information

These operating instructions contain all the information necessary for correct operation of the products described. The document is intended for specially trained, technically qualified personnel who are well-versed in all warnings and commissioning activities. The equipment is manufactured using state-of-the-art technology and is safe in operation. It can safely be installed and commissioned and functions without problems if the safety information in these operating instructions is followed.



WARNING

When operating electrical equipment, some parts of the equipment always carry dangerous voltages. Ignoring these safety instructions and warnings may result in serious personal injury and/or damage to property.

Only qualified personnel who are familiar with the safety information, assembly, operation and maintenance instructions may carry out work on this equipment.

Danger Information

On the one hand, the information below is for your own personal safety and on the other to prevent damage to the described products or to other connected equipment.

In the context of the operating instructions and the information on the products themselves, the terms used have the following meanings:



DANGER

This means that death, severe personal injury, or damage to property will occur unless appropriate safety measures are taken.



WARNING

This means that death, severe personal injury, or damage to property may occur unless appropriate safety measures are taken.

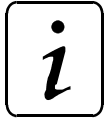

NOTE

This draws your attention to important information about the product, handling of the product or to a particular section of the documentation.

Qualified Personnel

In the context of the safety-specific information in this document or on the products themselves, qualified personnel are considered to be persons who are familiar with setting up, assembling, commissioning and operating the product and who have qualifications appropriate to their activities:

Trained or instructed or authorized to commission, ground and mark circuits and equipment in accordance with recognized safety standards.

Trained or instructed in accordance with recognized safety standards in the care and use of appropriate safety equipment.

Appropriate Use



WARNING

You may only use the equipment/system for the purposes specified in the operating instructions and in conjunction with the third-party equipment and components recommended or authorized by BAUMÜLLER NÜRNBERG GmbH.

For safety reasons, you must not change or add components on/to the equipment/system.

The machine minder must report immediately any changes that occur which adversely affect the safety of the equipment/system.

2 TECHNICAL DATA

2.1 General

The motor controller designated as the V-controller is a favorably priced, fully digital solution for Baumüller equipment for closed-loop control of synchronous and asynchronous motors.

The V-controller covers the range of functions of the existing E-controller and T-controller.

In addition, the two VeCon circuits increase the controller's computing power and storage capacity. This results in a significant improvement in the device's closed-loop control properties, quicker communications and increased open-loop control functionality in the closed-loop controller. Various option boards allow you to adapt the BUS 6 V-controller to a vast range of different requirements and applications.

Closed-Loop Control

- Field-oriented closed-loop control for synchronous motors with
 - Sinus encoder with 8 V synchronous-serial interface
 - Sinus encoder with 5 V synchronous-serial interface (from SW 14.08)
 - Sinus incremental encoder
 - Square wave incremental encoder
 - Resolver
- Field-oriented closed-loop control for asynchronous motors with
 - Sinus encoder with 8V synchronous-serial interface
 - Sinus encoder with 5V synchronous-serial interface (from SW 14.08)
 - Sinus incremental encoder
 - Square wave incremental encoder
 - Resolver

Closed-Loop Control Functions

- Speed control at 62,5 μ s
- Position control at 62,5 μ s
- Torque control at 62,5 μ s
- The digital closed-loop control offers
 - Drift-free operation
 - Exceptional concentricity properties
 - Highest levels of control dynamics and rigidity across the entire speed range
 - Speed actual value resolution
 - Resolver: 1 revolution $\cong 2^{12}$
 - Sine incremental encoder (e.g. ROD486) with 1024 increments: 1 revolution $\cong 2^{22}$
- Depending on the requirements, you can operate the controller by means of
 - Analog set value setting and digital switching inputs
 - RS485 serial port for drive networking using a busable protocol (compatible with USS protocol)
 - RS232 serial port for PC operation, parameterization, commissioning and service as well as for archiving control parameter to floppy disk.

Inputs / Outputs

- Digital inputs (24 V):
 - Pulse enabling
 - Rapid halt
 - 4 programmable function inputs
- Analog inputs:
 - 2 analog inputs (0 ... ± 10 V), 12 bit resolution
- Serial interfaces:
 - RS232 with a transmission rate of 9600 baud, optical separated
- Digital outputs:
 - 1 relay contact message „ready for use“
 - 3 programmable function outputs
- Analog outputs
 - 2 analog outputs (0 ... ± 10 V), 12 bit resolution

Operation Software

- WinBASS
- Up-/Download with PCBASS
- PCBASS

Optional Boards

- **Ω**mega Drive-Line
- InterBus-S interface
- CAN interface
- I/O module MFM-01
- Sercos interface
- 1 x analog input (0 ... ± 10 V), 16 bit resolution
- Profibus DP-Interface
- RS 485-Interface with a transmission rate of 300 to 19200 baud, optical separated

2.2 Electrical Data

Accuracy of whole system	Calculation accuracy 16 bit
Sampling rate of whole system	62,5 µs
2 analog inputs voltage range type input resistance resolution	-10 V ... +10 V differential input ca. 40 kΩ 12 bit
6 potential free inputs low level high level input resistance	0 V ... +7.5 V +13 V ... +30 V 2,5 mA
2 analog outputs voltage range maximum output current resolution	-10 V ... +10 V 1 mA 12 bit
1 relay output maximum contact load maximum potential against electronic ground	24 V DC / 1 A 50 V
3 potential free outputs joint supply voltage joint ground output current per output	+ 24 V / 150 mA ground of 24 V external 50 mA
Encoder emulation for more information see Incremental Encoder Emulation on page 107 external supply voltage current output level (RS 422-standard) output low voltage output high voltage	no. of increments adjustable 5 V +/- 5 % max. 100mA (without load) max. 0,5 V (at I _{OL} =48mA) max. 2,5 V (at I _{OH} =-20mA)
Interfaces	2 encoder interfaces to get absolute position RS232 service interface

Power Consumption

+5 V	1,2 A (without encoder supply; plus 0,5 A with 2 encoders)
+8 V	10 mA (without encoder supply; plus 0,5 A with 2 encoders)
+15 V	50 mA
-15 V	50 mA

2.3 Type Code

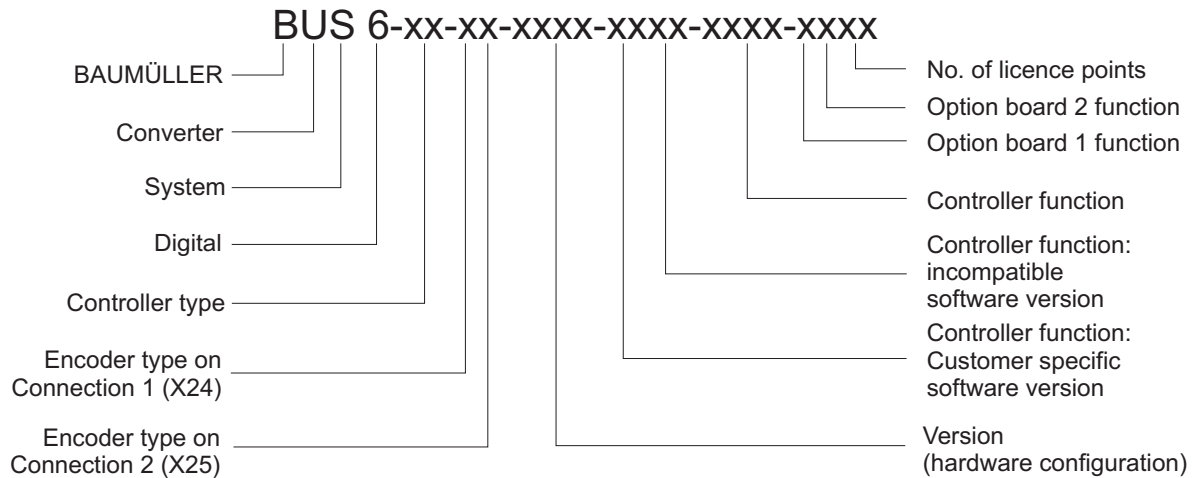

Type of Controller	VC	Vector Controller
Encoder type on connection 1: (X24)	0	No encoder
	A	Resolver
or	B	5 V sinus incremental encoder
Encoder type on connection 2: (X25)	C	Absolute value encoder with 8 V asynchronous serial interface
	D	Absolute value encoder with 5 V synchronous serial interface (from SW 14.08)
	E	5 V square wave incremental encoder
Version:	0001	V-controller, cassette version
	1002	V-controller with InterBus-S, built-in version
	0017	V-controller with MFM-01, cassette version
	etc.	
Closed-Loop Control Function:		
Customer-specific software version	00	No customer-specific software version
Incompatible software version	03	Software version 03.xx
Open-Loop Control Function:	0000	No Δ mega installed
	Axxx	Run-time software for minimal Δ mega
	Bxxx	Run-time software for Δ mega + CAN (multi-axis application)
	Cxxx	Run-time software for minimal Δ mega + MEM-03
	Dxxx	Run-time software for Δ mega + CAN (multi-axis application) + MEM-03
Option Board 1 Function	1	Incompatible software version 1.xx
Option Board 2 Function	0	Software specified by PCB version
No. of licence points	01	1 licence point
	02	2 licence points

Example:

BUS6 - VC - EC - 1008 - 0003 - D103 - 10 - 02

Controller Type:	VC	Vector Controller
Encoder type on connection 1:	E	Square wave incremental encoder
Encoder type on connection 2:	C	Absolute value encoder with asynchronous serial interface and 8 V supply
Version:	1008	V-controller; Ω mega with MEM-03; InterBus-S with expansion board; multifunction module; built-in version
Closed-loop control function		
Customer-spec. software version	00	No customer-specific software version
Incompatible software version	03	Software version 03.xx
Open-Loop control function	D103	Run-time software for Ω mega + CAN (multi-axis application) + MEM-03
Option board 1 function:	1	Incompatible software version 01.xx
Option board 2 function:	0	Software specified via PCB version of option board
No. of licence points	02	2 licence points

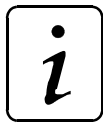

NOTE

Compared to the old type code, the positions for the encoder on connection 1 and connection 2 are interchanged.

3 TRANSPORTATION, UNPACKING

The units are packed at the factory in accordance with the order.

You should avoid jolting or dropping the package in transit, e.g. when putting the unit down.

You can start assembly after unpacking the equipment and checking that it is complete and undamaged .

The equipment is packed in cardboard, corrugated sheeting and/or wooden packaging that you should dispose of in accordance with local regulations.

Report any damage that has occurred in transit immediately.



DANGER

If the unit was damaged in transit, a qualified person must check, repair and test it before it may be connected.

Ignoring this information can result in death, serious personal injury or considerable damage to property.

4 ASSEMBLY

4.1 Dimensions

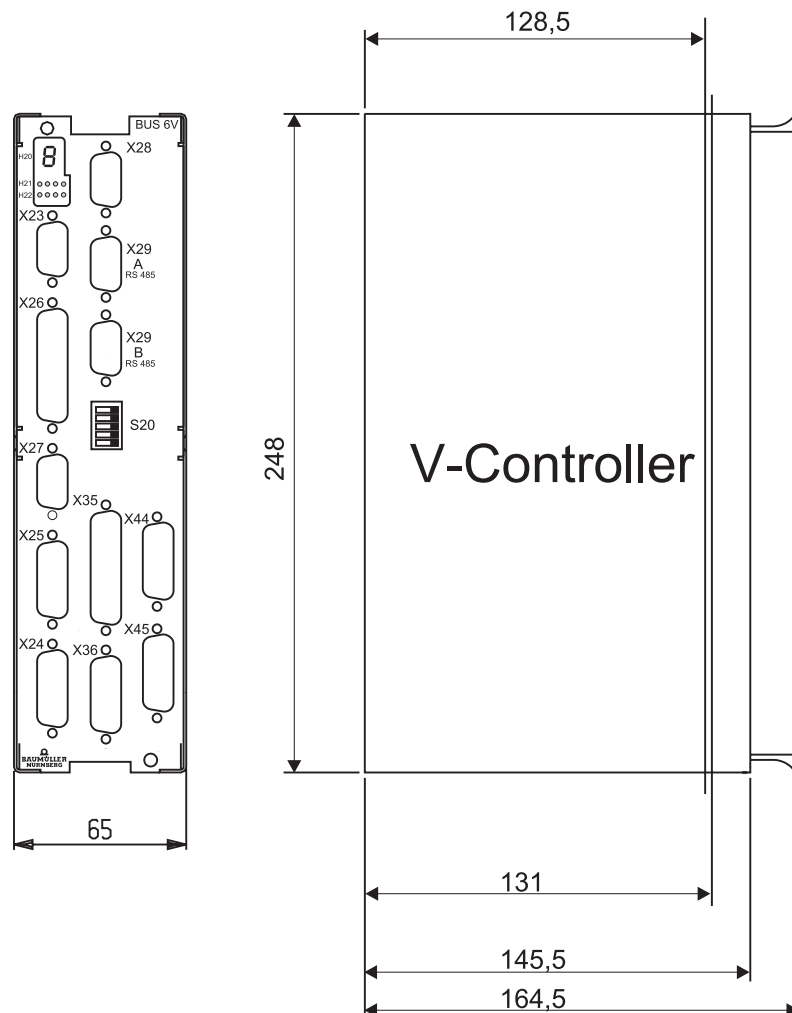

Plug-in depth of cassette

- BUS 6 and BUM 62: 128,5 mm
- BUM 63/64: 131,0 mm

The total depth can only be determined in conjunction with the basic unit. In addition, it is necessary to take into account the dimensions of the connector to be used (approx. 40 mm).

4.2 Assembly Note



WARNING

You are responsible for mounting the described equipment, the motor, the transformer and any other equipment in accordance with appropriate safety regulations (e.g. EN, DIN, VDE); equally you must ensure that all other relevant national or local regulations are met with regard to cable ratings and protection, grounding, disconnectors, overcurrent protection, etc.

During operation, the unit is protected from direct contact such that it is suitable for use in enclosed electrical premises (DIN VDE 0558 Part 1/07.87, Section 5.4.3.2, provisional standard EN 50178/VDE 0160/ 11.94, Sections 5.2.6, 5.2.7).

Plug the controller cassette into the appropriate recess in the basic unit and secure it with the two screws attached to it.

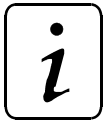

NOTE

Do not plug in the cassette under voltage!

The installation of the basic units is covered separately.

5 INSTALLATION

5.1 Danger Information



WARNING

You are responsible for mounting the controller in accordance with appropriate safety regulations (e.g. DIN, VDE); equally, you must ensure that all other relevant national and local regulations are met with regard to cable ratings and protection, grounding, disconnectors, overcurrent protection, etc.

The power converter's power cables are energized!

During operation, the principles on which the power converter and the motor work lead to leakage currents to earth that are dissipated via the specified protective earths and may result in a current-operated e.l.c.b. on the input side blowing prematurely.

Speed monitoring systems in the equipment must not just be complemented by a stand-alone monitoring system on the motor in the case of speed-critical drives. You can implement this control of the RPM speed, which is independent of the controller, by means of inductive, optical or torque-dependent encoders. Refer to the appropriate motor's operating and maintenance instructions.

Be particularly careful before touching the drive shaft directly or indirectly with your hands. This is only allowed when the system is deenergized and the drive is stationary.

Safety devices must never be deactivated.

According to applicable regulations (EN 60204 Part 1 and VDE 0113 Part 1), stopping the drive using the enable inputs of the control electronics does not, on its own, represent a safe stop condition. A disturbance in the power converter's control electronics can lead to accidental starting of the motor.

5.2 Checks Prior to Installation

- Note down the type code of the unit and motor
- Check the connections by means of the terminal diagram
- Connection of the plugs:

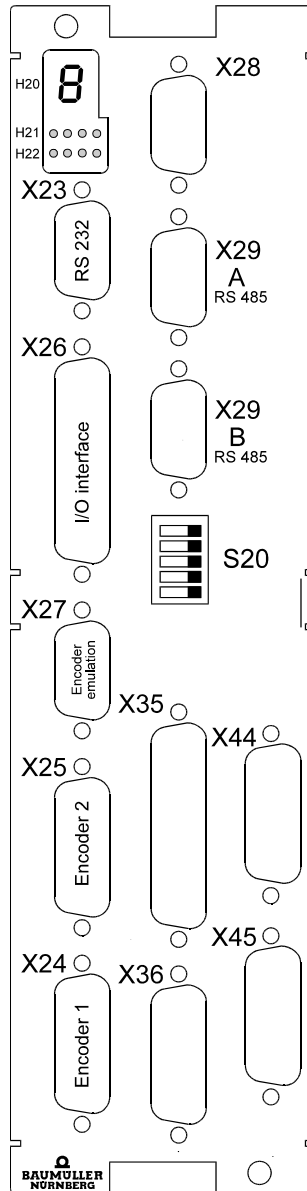

- PC connection via standard RS232
- Drive address set in binary code via DIP switch S20 if controller is equipped with optional board RS 485-Interface
- The locations of the plugs change as a result of various expansions of the standard V-Controller, e.g. by InterBus-S interface or Omega Drive-Line. Plug labelling and connector pin assignment, however, remains the same (see corresponding supplementary description).

5.3 Display

5.3.1 Seven-segment Display

A 7-segment display is attached to the front of the V-Controller, which shows the state in the drive manager's state machine (P120 - P133)..

Display	Meaning
0	NOT READY TO START
1	INHIBIT START
2	READY TO START
3	SWITCHED ON
4	OPERATION ENABLED
5	OPERATION ENABLED; command „operation disabled“ active
6	OPERATION ENABLED; command „shut down“ active
7	RAPID_HALT_ACTIVE
E	FAULT_REACTION_ACTIVE
F	FAULT

The following display mode is active **only** in the status FAULT:

Initially status identifier "F" is shown for three seconds to indicate the fault status. The "F" is followed by the four digits of the error code. The system outputs them with a decimal point, which clearly differentiates this status from the others in the device control. After the last digit, the system deactivates the display – apart from the decimal point – for one second. After this, the entire procedure is repeated.

If several errors are pending, the system, displays the entire list in this way.

If you acknowledge an error that is just being shown in display mode, the system still continues to display it until the end of this sequence. The next time the error list is processed, this error is no longer visible.

Example in the case of error codes 0801 and 0202:

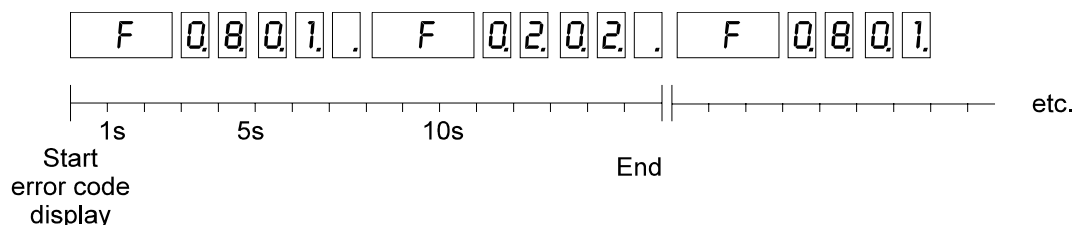

Information on error codes: see "Error Messages" on page 228.

5.3.2 LED Display Element

An LED display, which gives additional information, is located below the 7-segment display.

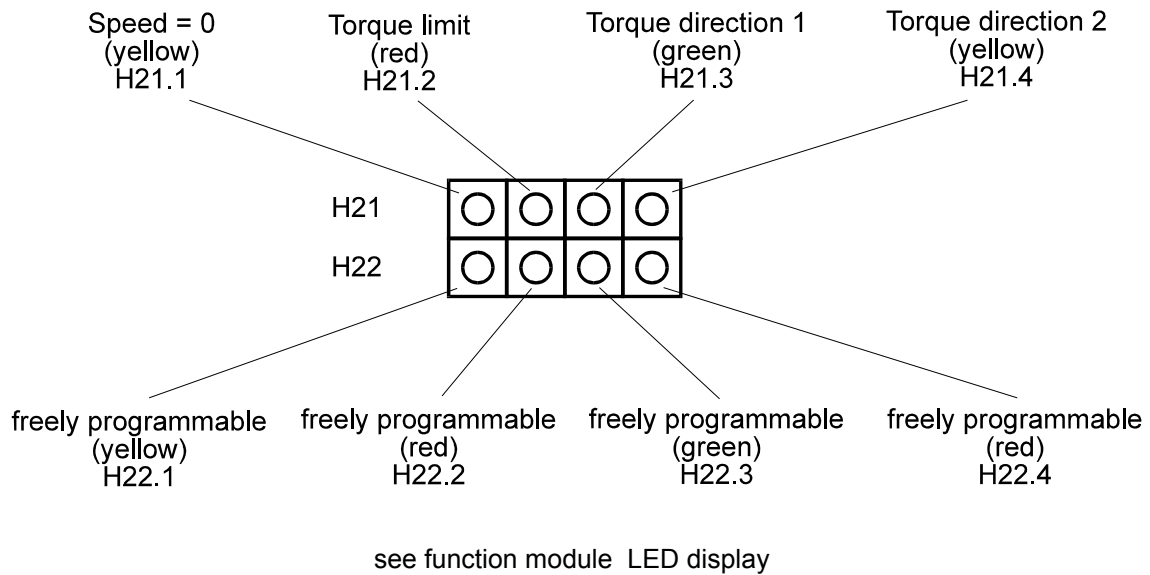

5.4 Terminal Diagram

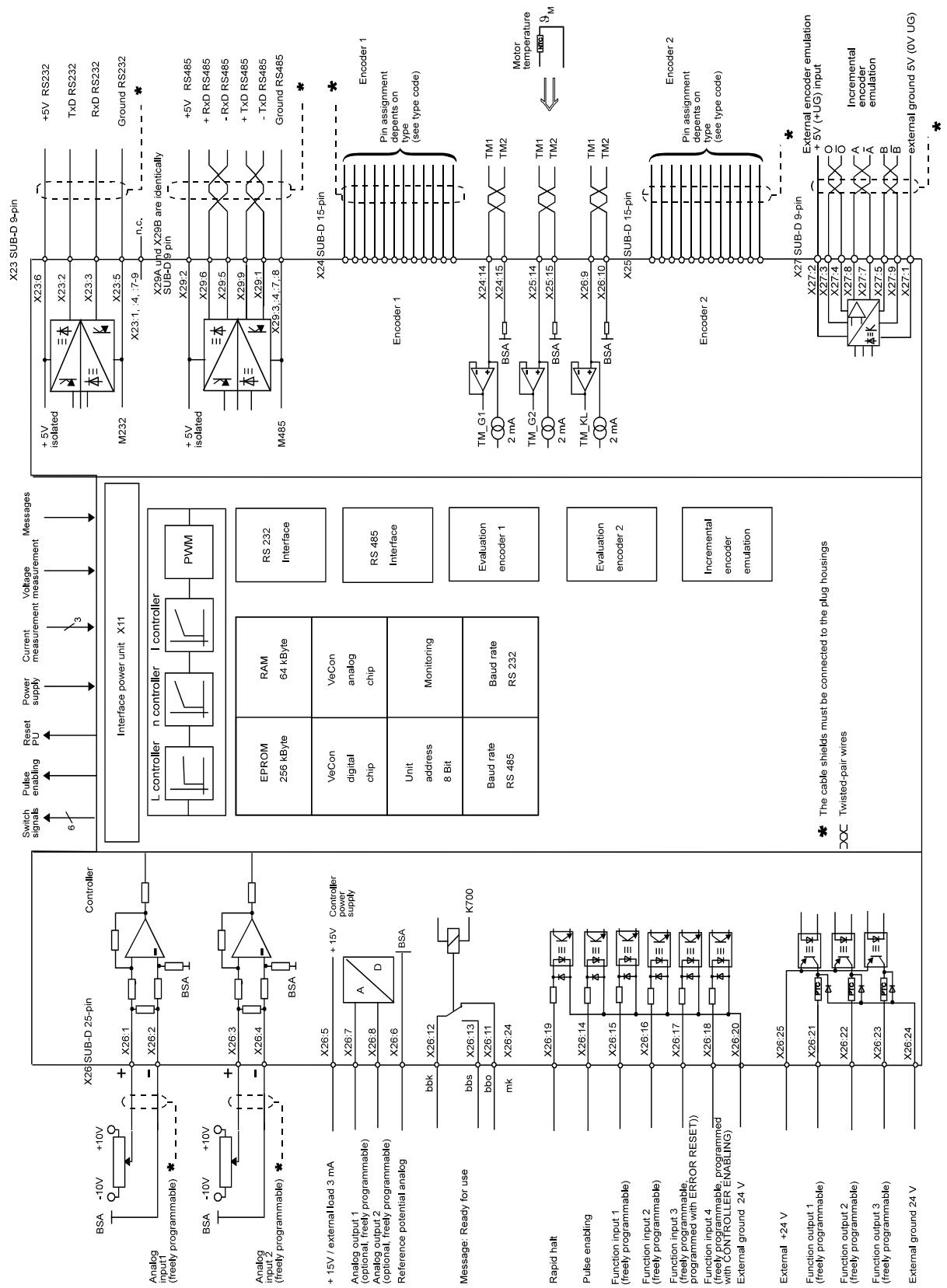

5.5 Connection of the Function Inputs

**M Mode P136 = 0 (Errors are acknowledged separately)
P136 = 1 (All errors are acknowledged together, default setting)**

The parameter of the module digital inputs must be programmed as follows:

Digital input 3	Digital input 4
P378 = 120	P342 = 120
P379 = 0080 ^{hex}	P343 = 0008 ^{hex}
P380 = 0000 ^{hex}	P344 = 0000 ^{hex}
P381 = 0080 ^{hex}	P345 = 0008 ^{hex}

Rapid halt
Pulse enabling
Function input 1 (freely programmable)
Function input 2 (freely programmable)
Function input 3 (freely programmable, programmed with **ERROR RESET**)
Function input 4 (freely programmable, programmed with **CONTROLLER ENABLING**)
External ground 24 V

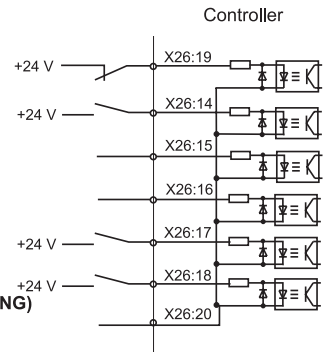

**M Mode P136 = 2 (Errors are acknowledged separately)
P136 = 3 (All errors are acknowledged together)**

The parameter of the module digital inputs must be programmed as follows:

Digital input 4
P342 = 120
P343 = 0008 ^{hex}
P344 = 0000 ^{hex}
P345 = 0008 ^{hex}

Rapid halt
Pulse enabling / ERROR RESET
Function input 1 (freely programmable)
Function input 2 (freely programmable)
Function input 3 (freely programmable)
Function input 4 (freely programmable, programmed with **CONTROLLER ENABLING**)
External ground 24 V

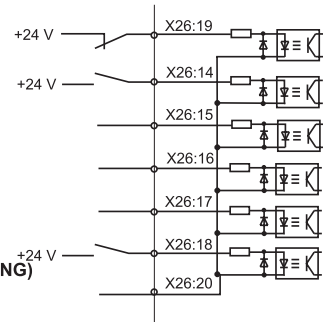

**M Mode P136 = 4 (Errors are acknowledged separately)
P136 = 5 (All errors are acknowledged together)**

The parameter of the module digital inputs must be programmed as follows:

Digital input 3
P378 = 120
P379 = 0080 ^{hex}
P380 = 0000 ^{hex}
P381 = 0080 ^{hex}

Rapid halt
Pulse enabling / CONTROLLER ENABLING
Function input 1 (freely programmable)
Function input 2 (freely programmable)
Function input 3 (freely programmable, programmed with **ERROR RESET**)
Function input 4 (freely programmable)
External ground 24 V

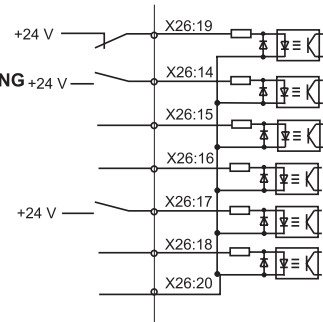

**M Mode P136 = 6 (Errors are acknowledged separately)
P136 = 7 (All errors are acknowledged together)**

Rapid halt
Pulse enabling / CONTROLLER ENABLING / ERROR RESET
Function input 1 (freely programmable)
Function input 2 (freely programmable)
Function input 3 (freely programmable)
Function input 4 (freely programmable)
External ground 24 V

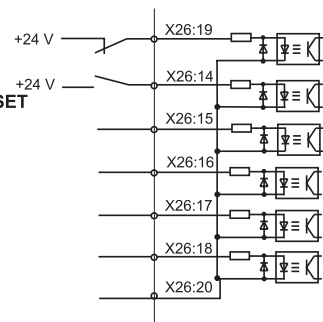

NOTE

All the enables are edge-triggered except for the emergency stop input. The emergency stop input must be active before the other hardware enables.

5.6 Connector Pin Assignment

RS232 Interface

X 23 SUB-D socket 9-pin

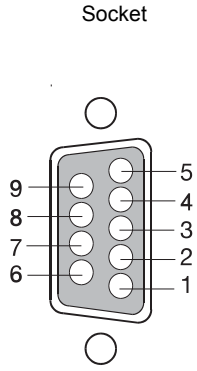
Socket	Pin no.	Assignment
	1	not assigned
	2	TxD RS232
	3	RxD RS232
	4	DTR, DSR
	5	ground RS232
	6	+5V RS232
	7	RTS, CTS
	8	RTS, CTS
	9	not assigned

RS485 Interface (optional)

X 29 A SUB-D socket 9-pin

X 29 B SUB-D plug 9-pin

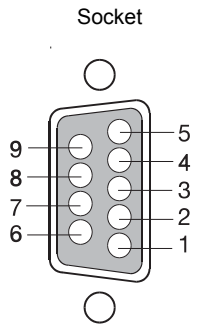
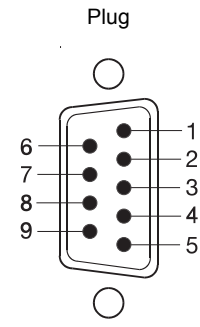
Socket	Plug	Pin no.	Assignment
		1	-TxD RS485
		2	+5V RS485
		3	ground RS485
		4	ground RS485
		5	-RxD RS485
		6	+RxD RS485
		7	ground RS485
		8	ground RS485
		9	+TxD RS485

Incremental Encoder Emulation

X27 SUB-D plug 9-pin

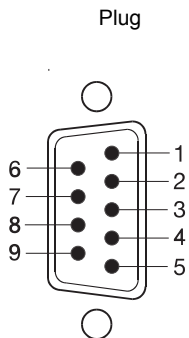

Pin no.	Assignment
1	ground incremental encoder emulation
2	external power supply +5V incremental encoder emulation
3	incremental encoder emulation 0
4	incremental encoder emulation -0
5	incremental encoder emulation B
6	not assigned
7	incremental encoder emulation -A
8	incremental encoder emulation A
9	incremental encoder emulation -B

Sine Encoder (e. g. z. B. Heidenhain EQN 1325, synchronous serial Interface 5V)

X24 / X25 SUB-D socket 15-pin (depends on type, X24 or X25)

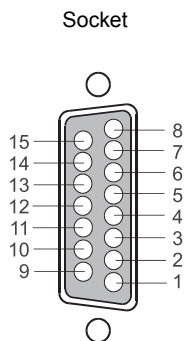

Pin no.	Assignment
1	ground
2	+5V encoder voltage
3	reserved*
4	reserved*
5	COS +
6	not assigned
7	SIN -
8	SIN +
9	COS -
10	clock +
11	clock -
12	sense +
13	sense -
14	RS485 +
15	RS485 -

* do not assign



NOTE

When using this encoder, the standard connection cable (see page 31) cannot be used.

Sine Encoder (e. g. Stegmann SCM70, asynchronous serial interface, 8 V)

X24 / X25 SUB-D socket 15-pin (depends on type, X24 or X25)

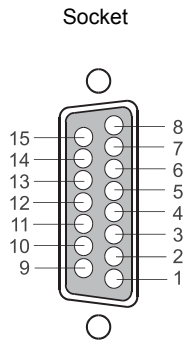

Pin no.	Assignment
1	ground
2	+8V encoder voltage
3	reserved*
4	reserved*
5	COS +
6	not assigned
7	SIN -
8	SIN +
9	COS -
10	not assigned
11	not assigned
12	RS485 +
13	reserved*
14	reserved*
15	RS485 -

* do not assign

Resolver

X24 / X25 SUB-D socket 15-pin (depends on type, X24 or X25)

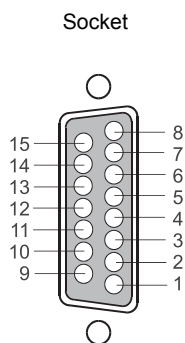

Pin no.	Assignment
1	resolver ref-
2	resolver ref+
3	not assigned
4	not assigned
5	resolver cos+
6	not assigned
7	resolver sin+
8	resolver sin-
9	resolver cos-
10	reserved*
11	reserved*
12	not assigned
13	not assigned
14	temperature motor TM1 (see note next page)
15	temperature motor TM2 (see note next page)

* do not assign

Installation

Rectangle Incremental Encoder (e. g. Heidenhain ROD 426) Sine Incremental Encoder 5 V (e. g. Heidenhain ROD 486)

X 24 / X 25 SUB-D socket 15-pin (depends on type, X 24 or X 25)

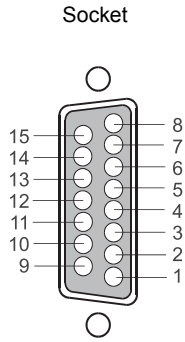

Pin no.	Assignment
1	ground
2	+5V encoder voltage
3	RS422 encoder +U0
4	RS422 encoder -U0
5	RS422 encoder +U2
6	not assigned
7	RS422 encoder -U1
8	RS422 encoder +U1
9	RS422 encoder -U2
10	not assigned
11	not assigned
12	reserved*
13	reserved*
14	temperature motor TM1 (see note next page)
15	temperature motor TM2 (see note next page)

* do not assign

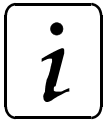

NOTE

A secure separation must be ensured externally for the motor temperature measurement of incremental encoder and resolver pin no. 14, 15.

Motor Temperature

Sockets X24, X25 and X26 provide three inputs for acquiring the motor temperature. Only **one of these inputs** may be connected. The other two inputs **must always** be open and cannot be used for additional external evaluation, because this can lead to corrupted measuring results or the destruction of the internal measuring circuit.

Controlling the Temperature Probe:

For this, you must remove the cable that is used to collect the motor temperature from the closed-loop control unit. While the motor is cold (coil temperature of less than 80° C), the resistance between the two connections in the cable must not exceed 1 kΩ.

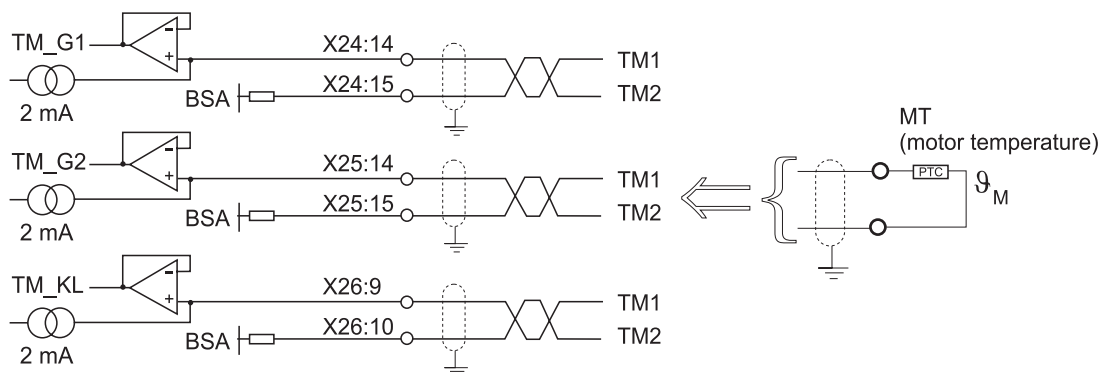

NOTE

The selection of the encoder input is set by parameter P152 MT mode.

Installation

Analog/Digital Interface

X26 SUB-D socket 25 pin

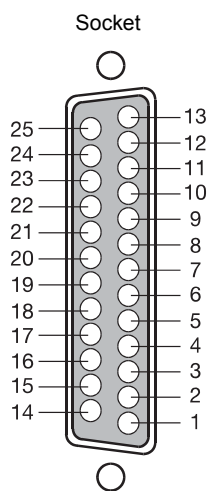

Pin no.	Assignment
1	analog input 1, differential signal +
2	analog input 1, differential signal -
3	analog input 2, differential signal +
4	analog input 2, differential signal -
5	analog power supply, + 15 V
6	analog power supply, reference potential
7	analog output 1
8	analog output 2
9	input motor temperature + **
10	input motor temperature - **
11	bbo relay break contact ready for use
12	bbk relay changeover contact ready for use
13	bbs relay make contact ready for use
14	pulse enabling (24 V)
15	digital input 1 (24 V)
16	digital input 2 (24 V)
17	digital input 3 (24 V), programmed with reset errors
18	digital input 4 (24 V), programmed with controller enabling
19	rapid halt (24 V)
20	ground for digital inputs 1 to 4 respectively pulse enabling and rapid halt
21	digital output 1 (24 V)
22	digital output 2 (24 V)
23	digital output 3 (24 V)
24	ground digital outputs 1 to 3
25	+24 V for digital inputs 1 to 4, pulse enabling, rapid halt and digital outputs 1 to 3

**



NOTE

A secure separation must be ensured externally.

5.7 Connection Cables

5.7.1 Connection Cable Encoder Types A, B, C and E

The following cable set is available for the connection of the encoder types A, B, C and E. BL encoder cable 12/15 pin, article no.: 1901 8001 (lengths on request).

Unit end, View of mating side

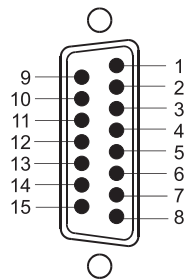

SUB-D plug, 15-pin

Motor end, View of mating side

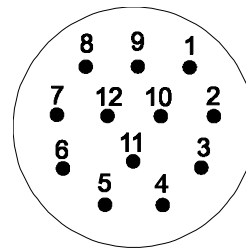

Metal round plug, 12-pin socket contacts (manufacturer Interconnectron)

Pin no.	Connection	Pin no.
1	blue Ø 0.5mm	10
2	red Ø 0.5mm	12
3	yellow	3
4	green	4
5	violet	8
6		
7	grey	6
8	pink	5
9	black	1
10		
11		
12	brown	2
13	white	11
14	red/blue	9
15	grey/pink	7

Cable: LiYCY 5x(2x0.14)+2x0.5mm² cores twisted in pairs, total shielding via copper.

The cable shield is connected to the round plug housing and the SUB-D plug connector shielding.



NOTE

The connecting cable must be manufactured in accordance with the above table!

The cable will not function with a deviating pin assignment!

The cable cannot be used for encoder type D!

5.7.2 Serial Connection Cable for PC



NOTE

Connect PC in control cabinet or via isolating transformer.
Refer to additional description WinBASS or Up-/Download for explanation of operating program.

- 9-pin PC connection (interface cable PC, part no. 1901 8006)

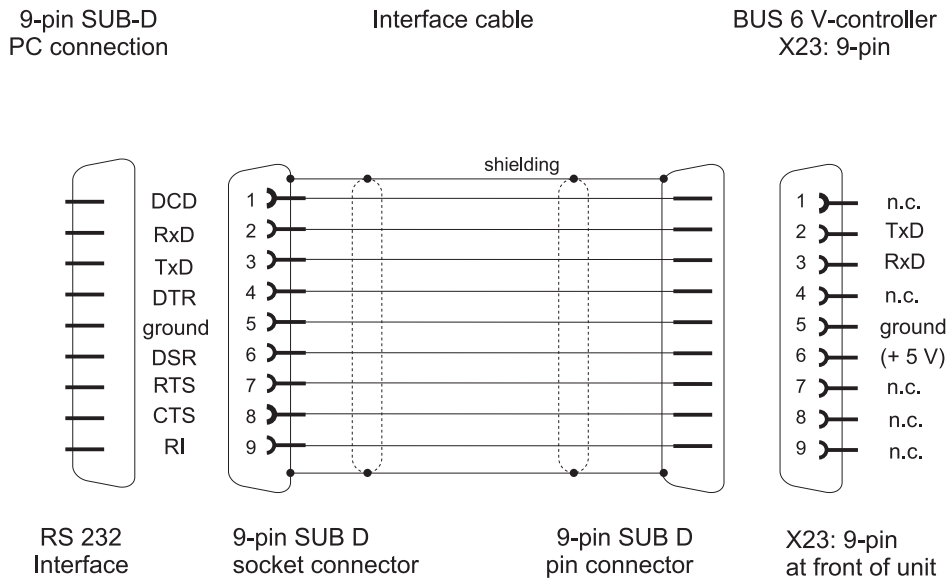

- 25-pin PC connection (not available)

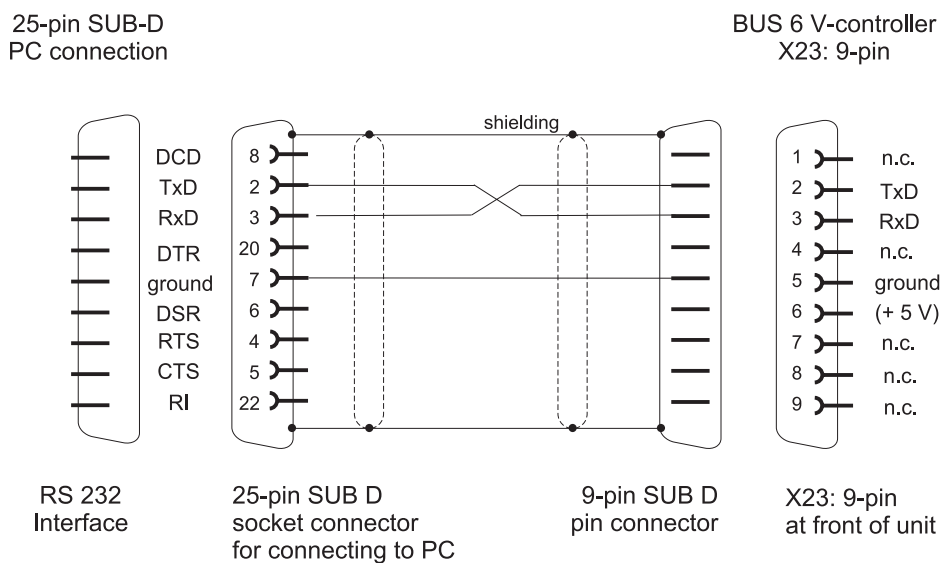

Connection Terminal Ring Circuit RS232

The units must be connected as follows, if more than one unit (up to 16) are connected in a ring circuit. :

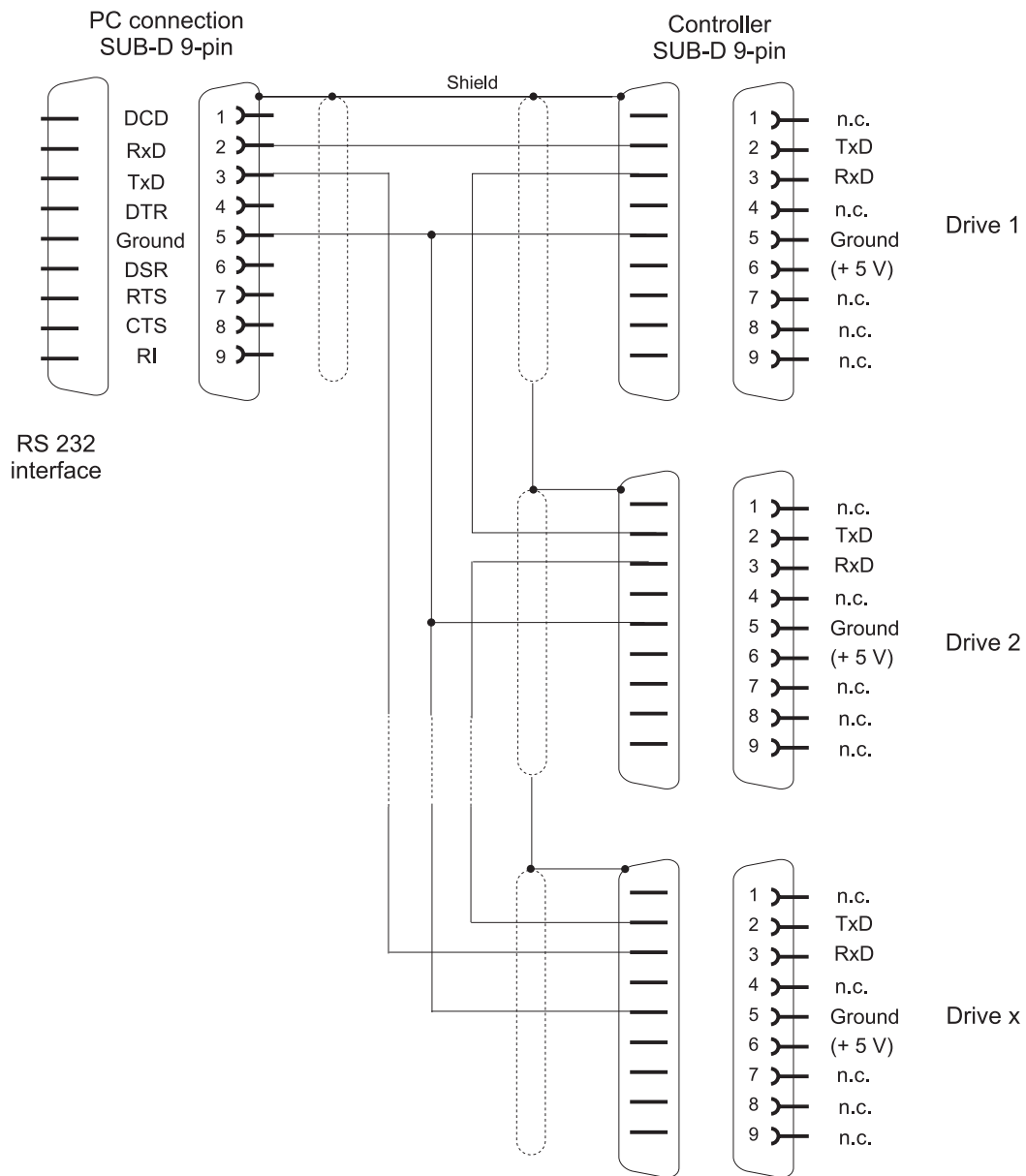

5.7.3 Connection Cable RS485

- 4 wire connection from master to 1. slave

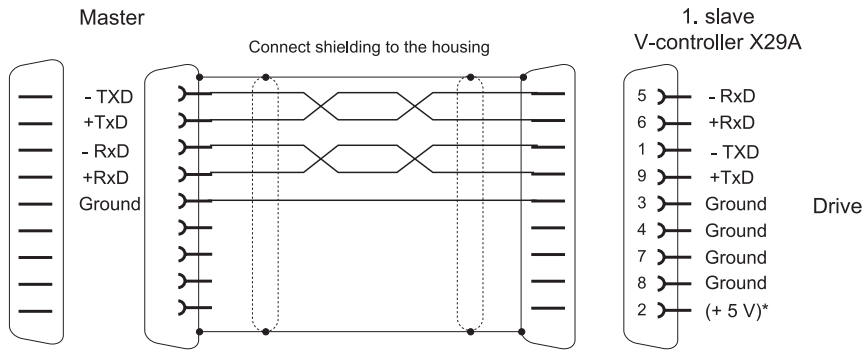

- 2 wire connection from master to 1. slave

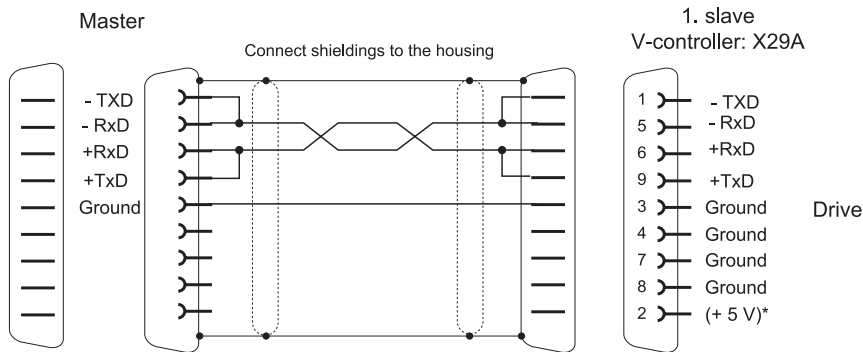

- Connection between 1. slave and 2. slave (and so on)

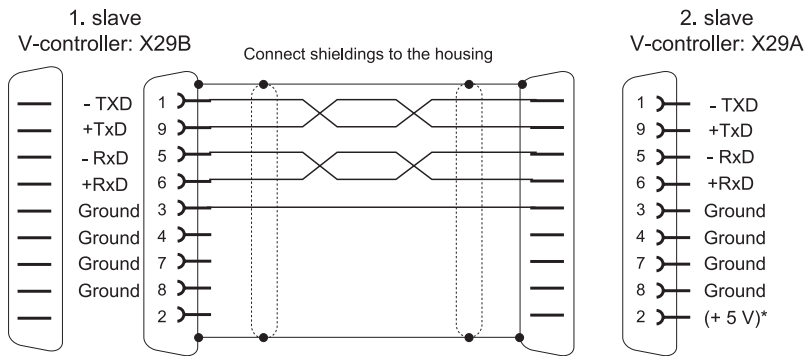

- Terminating socket for the last slave

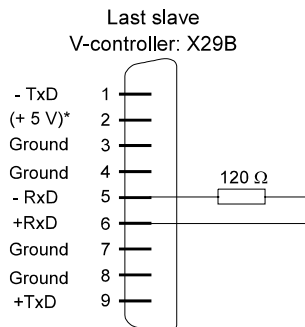

* The +5 V are reserved for the power supply of RS485/RS232 adapters and must not be connected.

5.7.4 Connection of Leading Axis and Following Axis

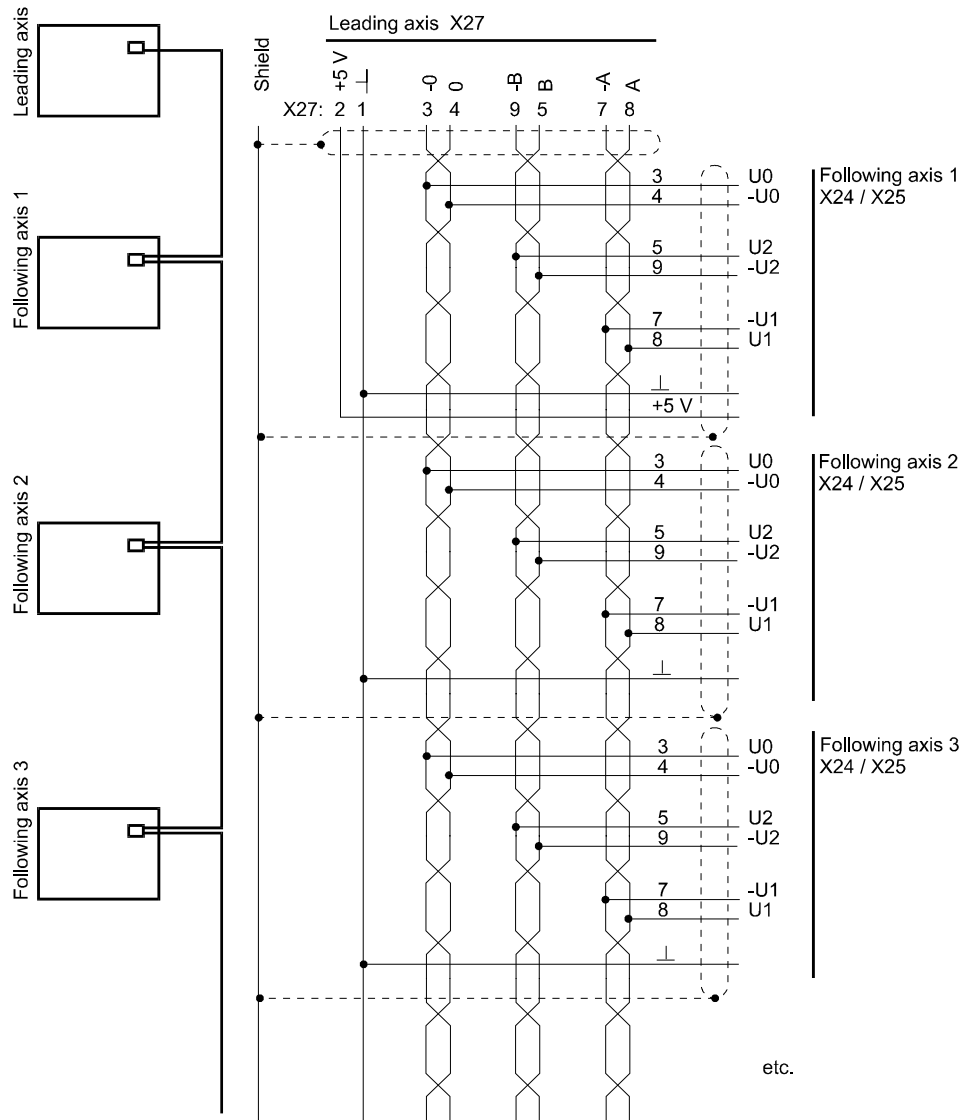

5.8 Accessories

	Part no.
• Bus cable X27 A/B RS485	1901 8026
• Interface cable PC (3 m) X23 RS232	1901 8006
• BL encoder cable 12/15 pin. (cable length on request) X24/X25 Encoder	1901 8001

6 COMMISSIONING

6.1 Danger Information



WARNING

This equipment carries a dangerously high voltage and, depending on the version, may have dangerous rotating parts (fans). Ignoring the safety and warning information may result in death, severe personal injury or damage to property.

You are responsible for mounting the power converter, the motor, the commutating reactor and any other equipment in accordance with appropriate safety regulations (e.g. DIN, VDE); equally, you must ensure that all other relevant national and local regulations are met with regard to cable ratings and protection, grounding, disconnecters, overcurrent protection, etc.

The most important factors for protecting people are the DIN/VDE protective measures and safety regulations. If there are no protective earth connections on the equipment, commutating reactor or the motor, personal injuries are inevitable, since the surfaces may carry dangerously high voltages.

The power converter's power cables are energized!

The mains unit and the field connector of the power converter carry a dangerous voltage even when the main contactor has dropped.

During operation, the principles on which the power converter and the motor work lead to leakage currents to earth that are dissipated via the specified protective earths and may result in a current-operated e.l.c.b on the input side blowing prematurely.

In the case of a short-circuit to frame or to ground, a direct proportion may arise in the leakage current that makes triggering a higher level current-operated e.l.c.b either more difficult or totally impossible.

Make the PE connection in accordance with DIN EN 60204/VDE 0113 Part 1/06.93; Section 8.2.2 taking into account provisional standard EN 50178/ VDE 0160/11.94, Sections 5.3.2.1 and 8.3.4.4.

Before carrying out commissioning, check whether the plastic covers over the power stage connections are in place.



WARNING

If an error occurs, the drive is deenergized and then coasts unbraked to a standstill. You should consider this situation particularly with motion and lifting drives.

Faulty drive response

During initial commissioning, faulty or uncontrolled motion of the driven machine elements is always possible. At this stage, you should therefore proceed with particular care.

Before switching on the drive, you must carefully check the functions of all the higher level safety equipment to prevent injury to people.

Take particular care when directly or indirectly touching the drive shaft with your hand. This is only allowed when the shaft is stationary and the power converter is deenergized. Any exposed parts of the machine, such as the shafts, fans, etc., must be covered during operation.

Contact protection in accordance with paragraph 4 Section 4 VBG 4

Protection against direct contact comprises all the measures against danger that can result from touching the active parts of electrical equipment.

You must therefore protect the active parts from being touched by means of insulation, the construction and arrangement of the equipment or permanently mounted guards. The guards in question are standard covers, barriers and procedures that guarantee that people cannot touch active parts that are carrying power.

Switching cabinets must have an emergency off facility to switch off any voltages that could be dangerous. This does not include equipment which, if switched off, would cause an even more dangerous situation. The emergency off releasing element must be arranged in such a way that it can be reached quickly in case of danger. In the case of work that is considerably more dangerous than usual, another person must be present.

The machine minder must ensure that unauthorized people do not work at the machine.



WARNING

The machine minder must report immediately any changes that occur at the machine which adversely affect safety.

When dismantling safety equipment during commissioning, repair and maintenance work, you must ensure that the machine is taken out of commission in accordance with applicable regulations. You must remount and check safety equipment immediately after completing commissioning, repair and maintenance work.

This list of measures required for safe power unit operation is not complete. If you should need further information or if special problems arise please contact BAUMÜLLER NÜRNBERG or a sales agency. Please observe the warnings in Chapter 1 of these operating instructions.



NOTE

Before touching the modules, the operator must release any electrostatic charge to protect electronic components from high voltages generated through electrostatic charge, by simply touching a conductive, grounded object immediately before, for example.



This label is placed in a visible location on units with electrostatically susceptible components and / or modules.

6.2 Initial Commissioning of V-Controller

6.2.1 Hardware requirements

A certain minimum setup of the drive components is required to commission a drive. The following diagram shows how the components of a drive could be connected. Observe safety notes which are given in the manuals of every component. Make a note of the controller type code e.g. BUS 6-VC-..., the converter type code e.g. BUM... and the motor article number (refer to the rating plates).

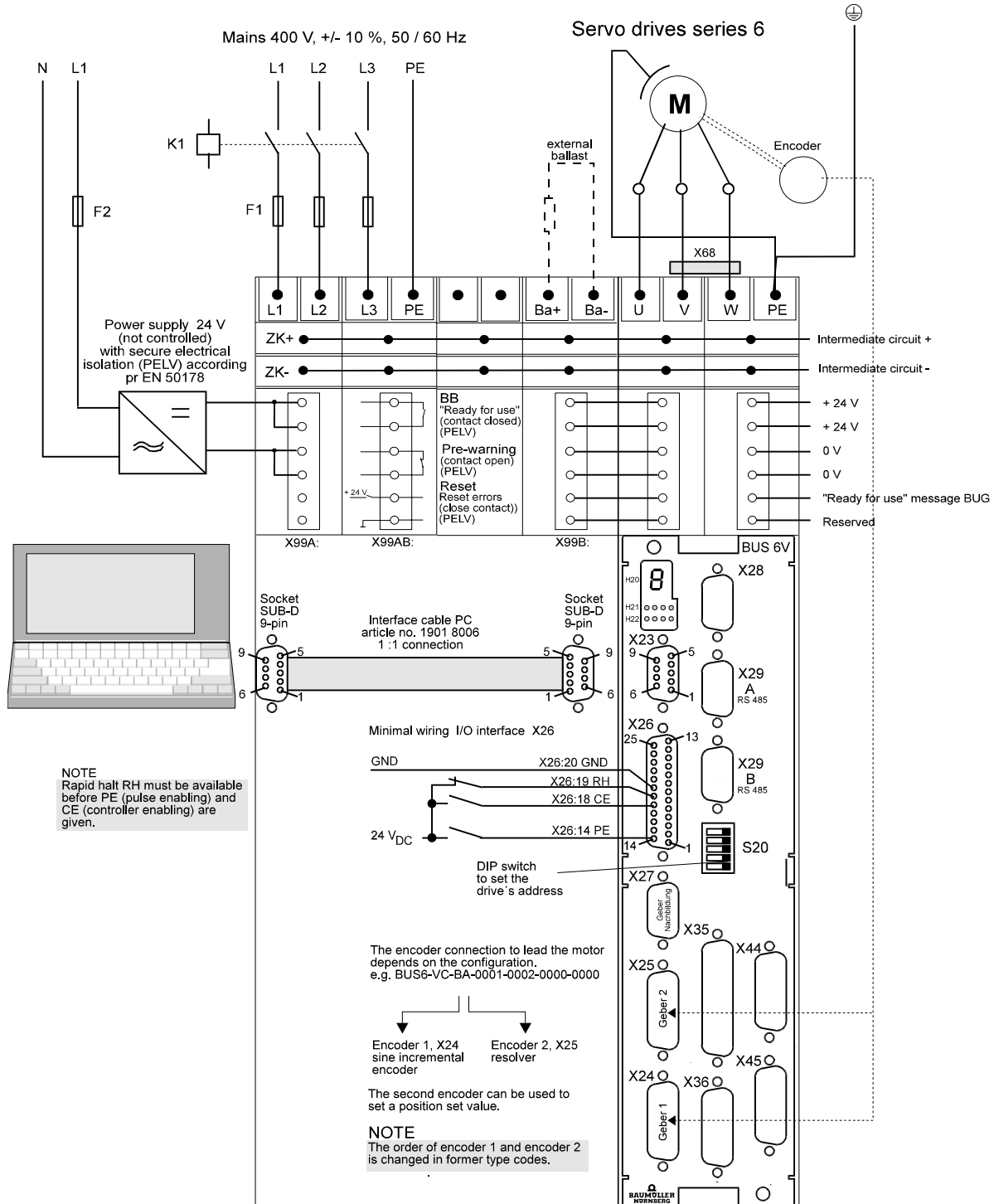

6.2.2 Installation WinBAS

WinBASS PC hardware and software

IBM compatible PC with

- Pentium processor (at least Pentium II)
- at least 16 MB RAM (Windows 95)
at least 32 MB RAM (Windows NT)
- 40 MB free hard disk memory
- CD-ROM drive (at least 8x reading speed)
- at least VGA graphic adapter
- free serial port (COM1 to COM4)
- Operating system: Windows[®] 95 or Windows[®] NT 4.0

Baumüller-Software

- GUI WinBASS V5.xx

Installation

To install the program under Windows 95 proceed as follows (the installation under Windows NT4.0 is to be done accordingly):

Start your computer and make sure that Windows 95 is loaded as active operating system.

Make sure that all applications are closed before you start the installation.

Insert the WinBASS CD into the CD ROM drive of your computer.

If the function "Auto play" of your computer is activated the WinBASS welcome screen appears after a short time.

If this function is not active, start the installation program manually. Click on the "Start" button in the taskbar of the operating system; select the "Execute" menu item. Enter *CD drive:\setup.exe* in the text box "Open" and click on "OK". Select your language first.



The set-up then looks for already installed WinBASS versions and displays these, if any. Click on "Setup" to start a new installation or "Update" to update an existing version.

Commissioning

To start the set-up routine, click on the "Setup" button.

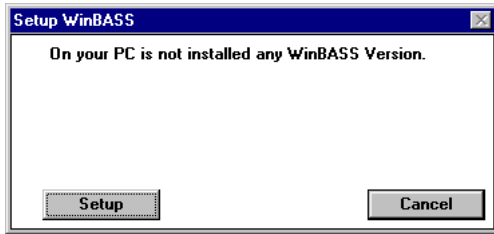

After clicking on "setup", the welcome dialog is displayed. If you click on the "Next" button, the General Terms and Conditions of License follow.

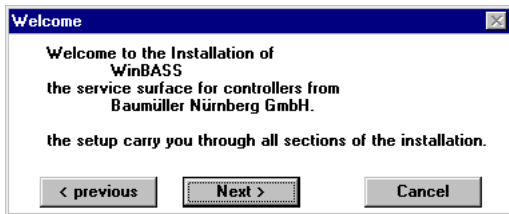

With a click on the "Yes" button you accept the General Terms and Conditions of License of Baumüller Nürnberg GmbH.

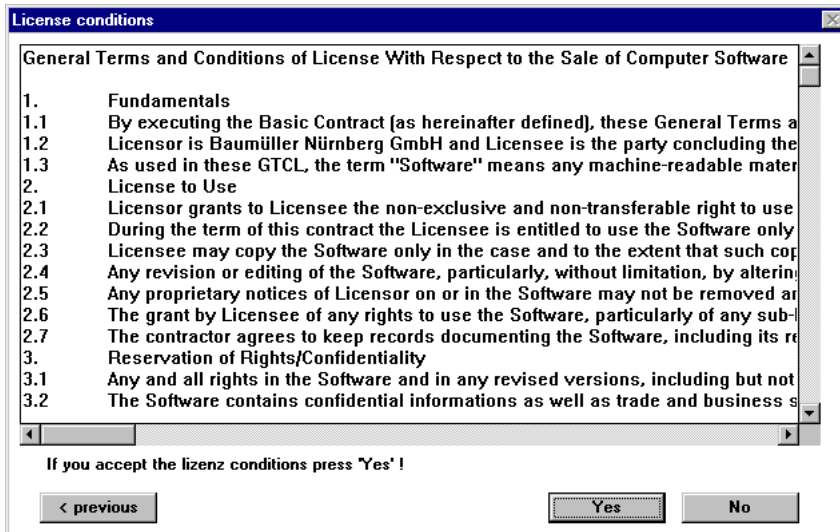

Then enter the user name and the serial number which is printed on the CD cover.

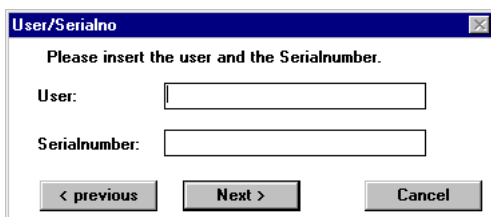

Two boxes for the entry of the directory are displayed. Enter the desired installation drive and the installation directory for the source and target files. Please observe the DOS name restrictions (max. 8 characters) of the path. To continue the installation click on "Next". The program files are now copied to the specified target directory on your hard disk.

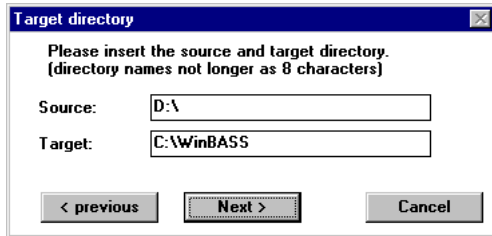

After you have copied the program files successfully, you are requested to enter the group name for the Windows 95 start menu. You can accept the suggested name "Baumüller" or enter another one. Click on "Next" to continue the installation.

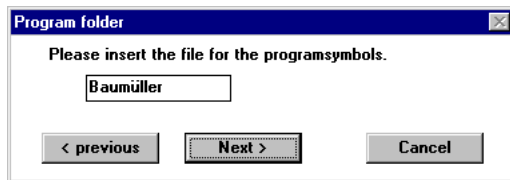

The data which you have entered are shown on the next screen. You start the copying of the file by clicking on the "Install" button.

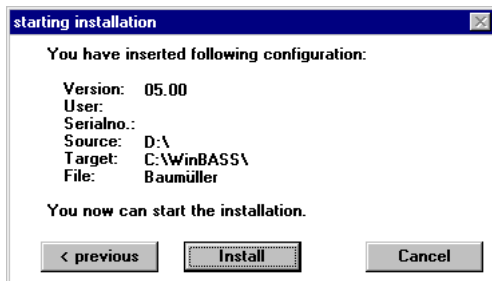

Then, the successful installation is displayed. Click on "Close" to complete the installation program.

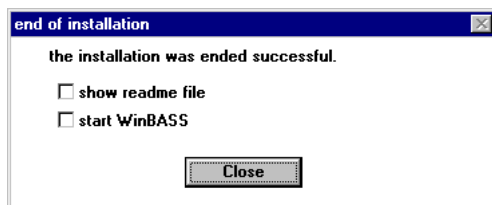

The WinBASS graphic user interface for controllers is installed now on your computer and you can start the commissioning of your drive record.

6.2.3 Guided commissioning

Carefully observe the safety notes in the controller descriptions of the individual components for guided commissioning. Another prerequisite is that the components as described in **Hardware requirements** on page 40 have a minimum wiring.

After you have wired and checked the components, apply the supply voltage, eliminate possible errors as described in the device descriptions and start the controller operating program as follows:

Select the "Programs" menu item in the Windows 95 start menu. Go to the "Baumüller" program group and then click on the "WinBASS" link.

When you start WinBASS for the first time, you are prompted to select your communication port. Click on the serial port you are using (the COM port of your computer). The selection is confirmed by clicking on the "OK" button.

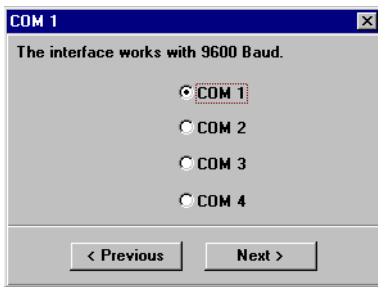

Next you select the used controller family (V)ector(C)ontrol:

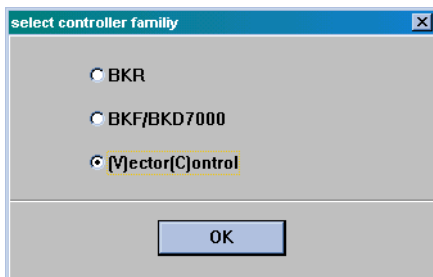

The configuration window appears.



NOTE

Because the configuration window is opened again in the guided commissioning, you can close it now with "OK" or "Cancel".

The initial WinBASS screen appears. To start the guided commissioning, please click on the "Commissioning guide" button.

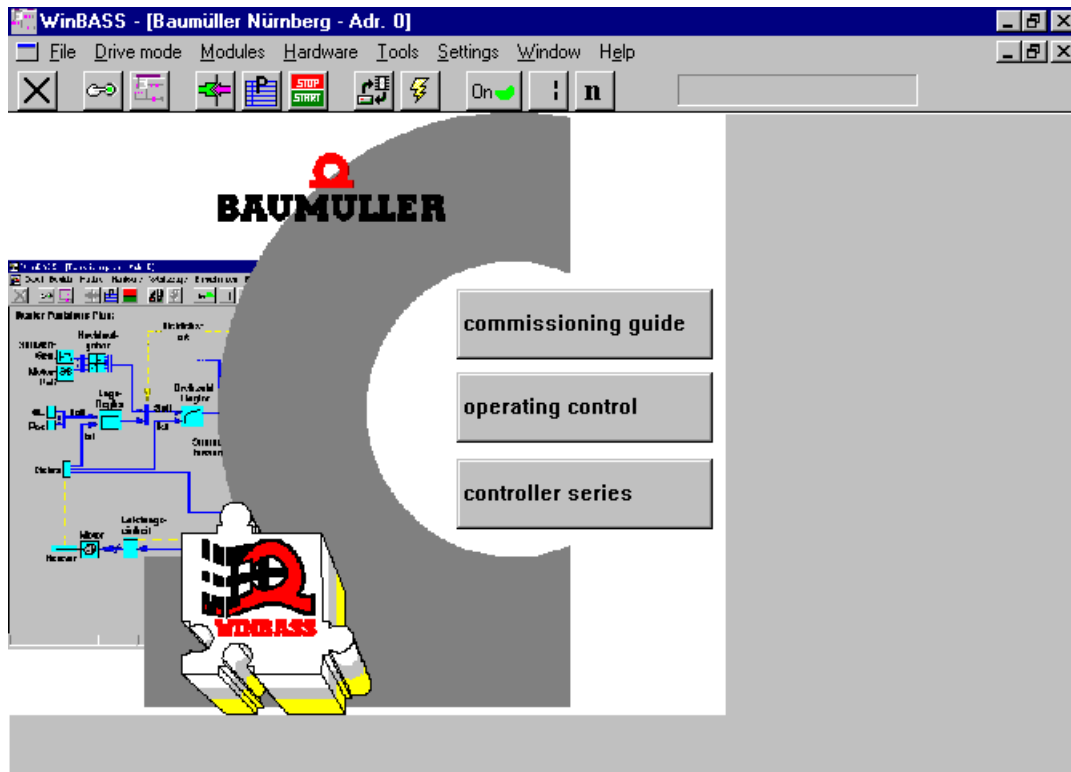

Now you are asked for the commissioning mode. For this, click on the "Online" button so that commissioning is carried out together with the controller.

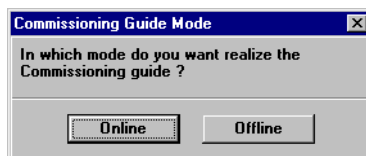

When you start the guided commissioning, you are prompted to select your communication port. Click on the serial port you are using (the COM port of your computer). Click on the "OK" button and communication with the controller is started.

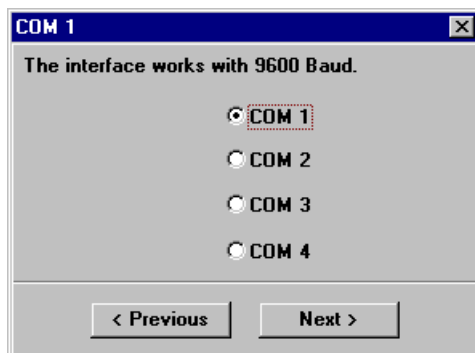

After communication to the controller has been established, its configuration is determined (as far as possible). The result of this scan is displayed on the configuration screen.

Commissioning

Please compare the data with those which you have written down in **Hardware requirements** on page 40 (for explanation of the type key see the controller description).

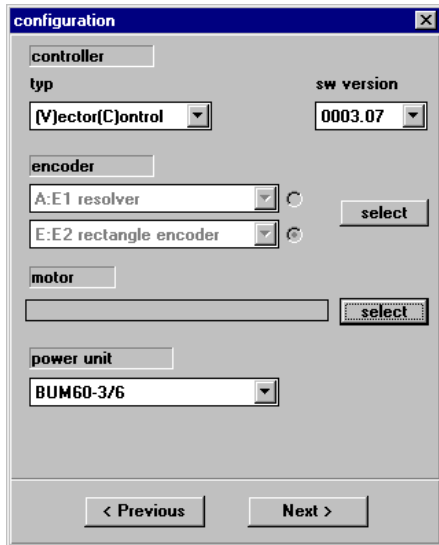

If you have connected a rectangular incremental encoder at encoder input 2 for instance, check the set number of increments. Click on the "Select" button at the right side next to the box of set encoders.

The encoder selection menu is displayed. Please check whether the set data is correct. If necessary, change the settings and confirm them by clicking on the "Ok" button. After this you return to the configuration window.

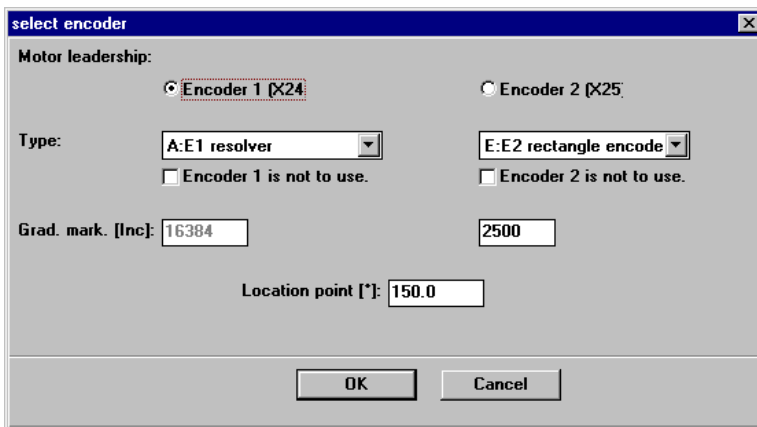

As no data is displayed in the "Motor" field, click on the "Select" button at the right side next to the "Motor" field. The motor selection menu is displayed. Select the motor type from the list field.

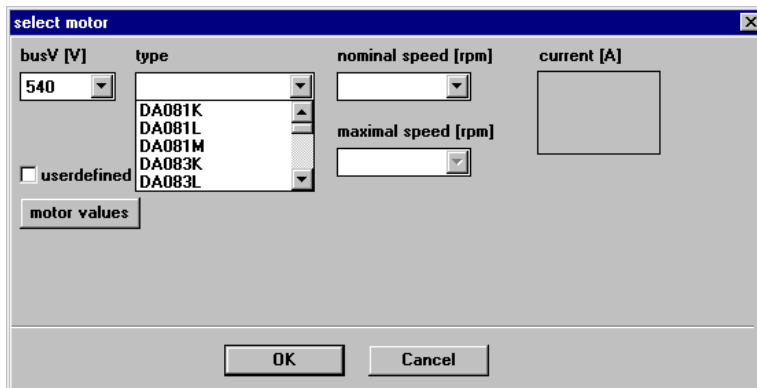

After you have selected the motor type, the list field for the rated speed of your drive opens. Select the rated speed specified on the motor.

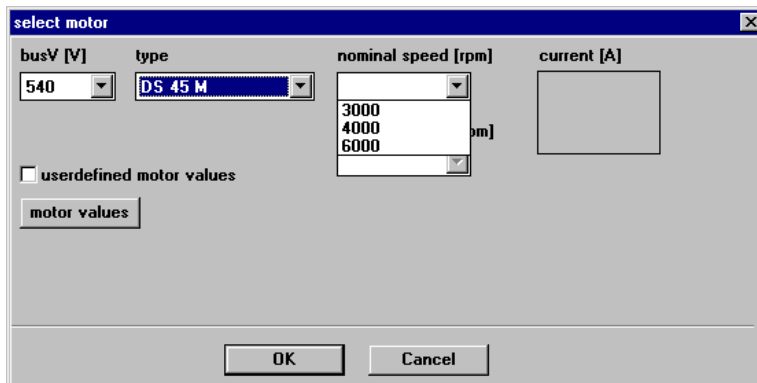

Immediately after the selection of the rated speed, the motor currents from the motor database are displayed in the corresponding window. Please check this data whether it is identical with the motor data on the motor nameplate. Click on the "OK" button to accept the set data and return to the configuration window.

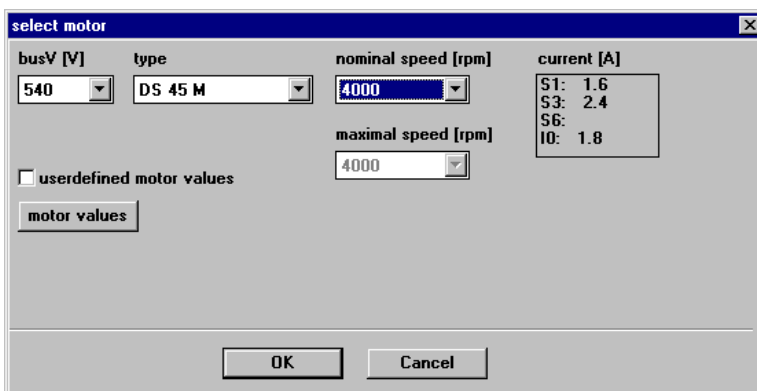

If your motor should not be listed, click on the menu item "User-defined motor values" and a window opens in which you can enter individual motor data (from the nameplate or the motor datasheet).

Commissioning

Once the data is entered, click on the "OK" button to return to the motor selection window.

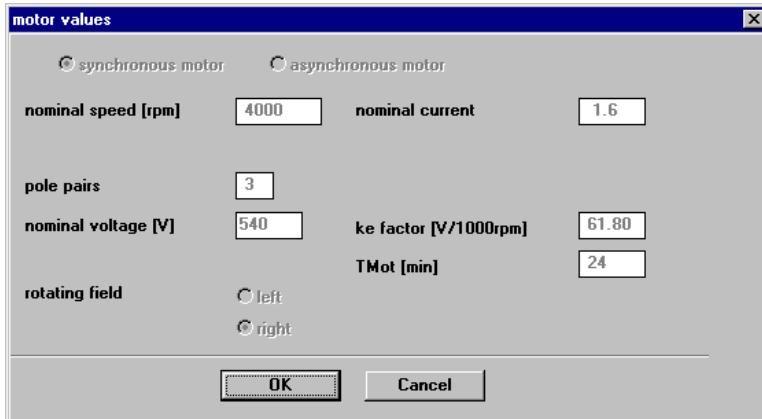

Now you are in the configuration window and you can check the set configuration data again. When the data are identical with those of your drive record, click on the "Continue" button to continue the initial commissioning.

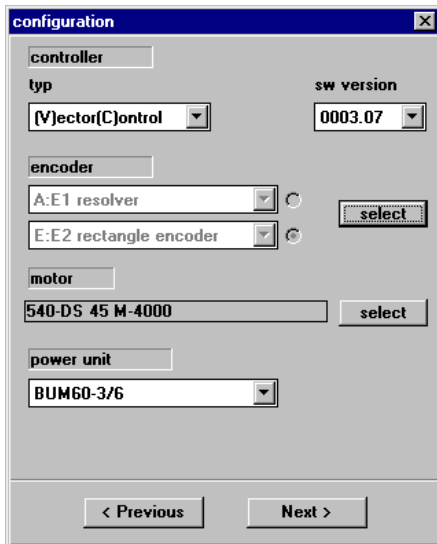

After the configuration data have been set, the selection window for the operating mode is displayed. Speed control is preset as the operating mode for initial commissioning. The menu item "Init with default values" is used to determine whether the controller is written with default values from the operating program. The menu item "Set config data" determines whether the data defined in the previous windows are saved in the controller memory. To continue the commissioning, click on the "Continue" button. If you have selected at least one of the two options, data is written now to the controller.

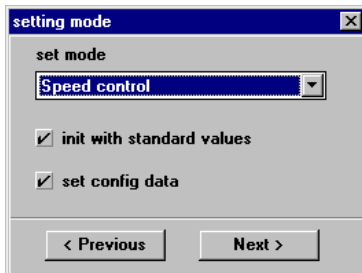

The data transmission to the controller is completed when the next window is displayed. If data which will become effective only after a restart, is modified in the controller, you can save the new data record in the controller now and then restart it. To save the data record, click on the "Yes" button. Otherwise, the data record remains in the RAM (volatile memory) of the controller and the next window is skipped.

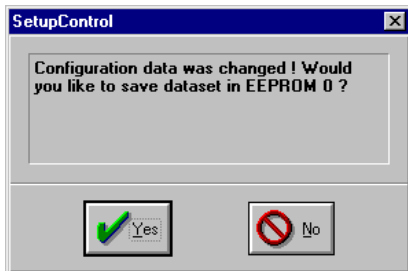

After the successful saving a confirmation window is displayed. Please close this window by clicking on the "OK" button.

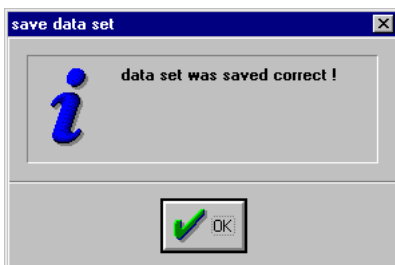

Once you have saved your data record, you can restart the controller (this procedure is called booting), since some changes will become effective only after a restart of the controller. For this, disconnect the controller from the 24V-supply for approx. five seconds. After you have booted the controller, continue commissioning by clicking on the "OK" button.

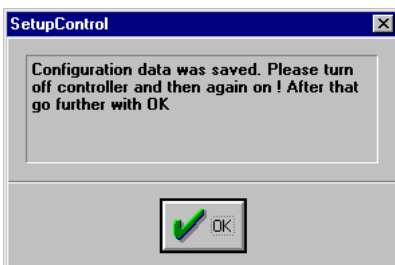

The home position must be determined now so that the controller can calculate the electrical angle. The homing mode of the home position can be selected using a list field. For a detailed description of the individual modes please refer to **Field Angle Calculation** on page 92. For the "Guided commissioning" mode, the zero method is used, i.e. the drive must be decoupled and able to rotate freely.

To start the procedure, set the hardware enables (inputs) at the controller (first quick stop (rapid halt), then pulse enable) and then click on the "Start" button.

Commissioning

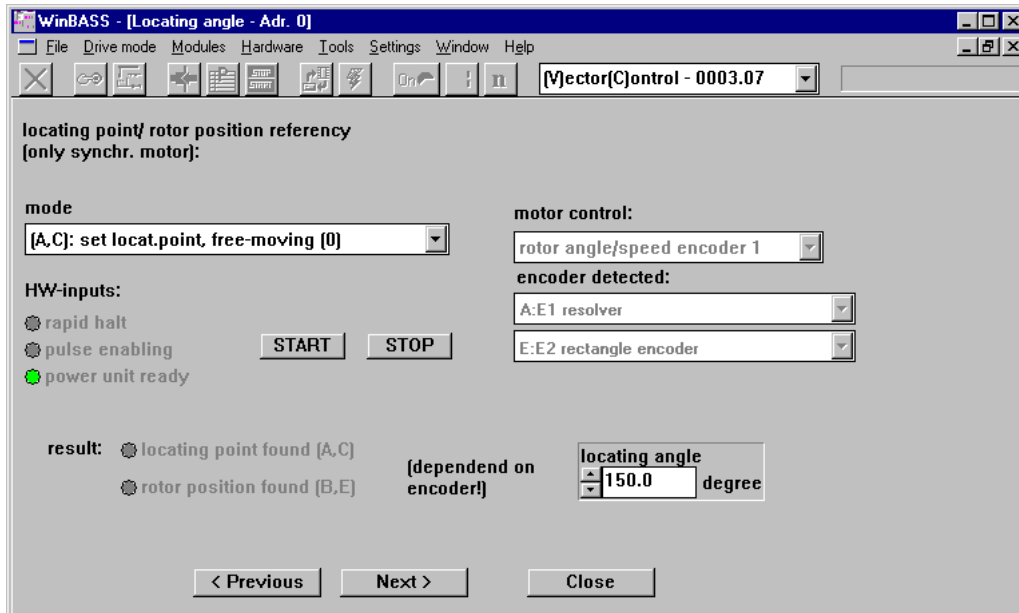

The motor now rotates to the home position. If this procedure is completed, the display "Locating point found" is illuminated and the determined homing angle is displayed (resolver approx. 150 degrees, Sincos encoder approx. 240 degrees). Click on the "Stop" button now and switch off the hardware enables (inputs). To continue the installation click on "Next".

After the home position of the drive has been referenced, the drive can now be operated in speed control. For this, the following window opens.

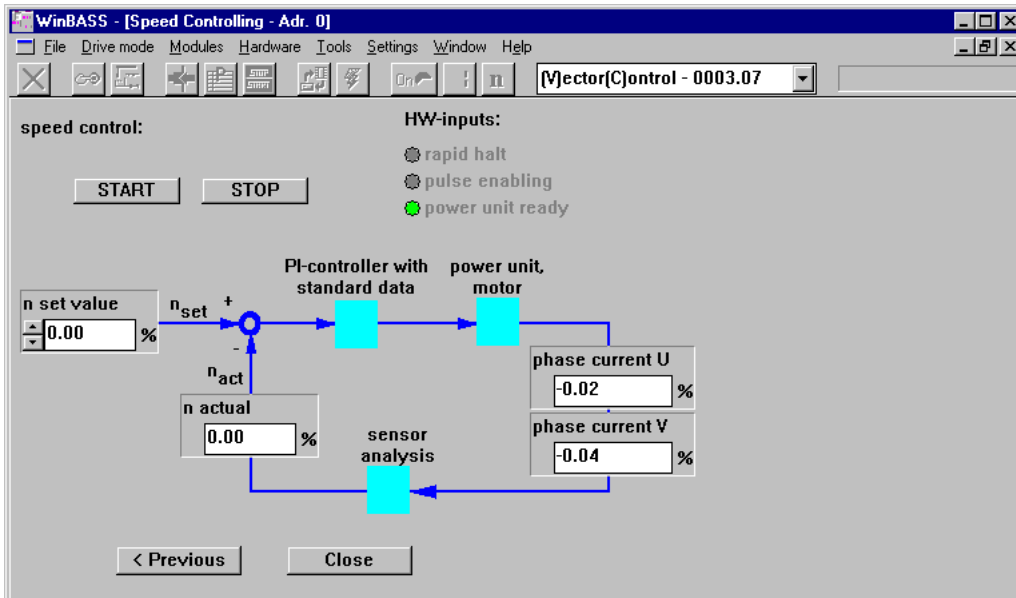

Enter a value in the "n-set value" field, connect the hardware enables (inputs) and start the drive by clicking on the "Start" button. The motor should rotate now with the speed which results from the specified value. To stop the drive, click on the "Stop" button.

To complete commissioning, click on the "Close" button and you can save again the RAM data record in the EEPROM. For this, click on the "Yes" button. After the successful saving a confirmation window is displayed. Please close this window by clicking on the "OK" button.

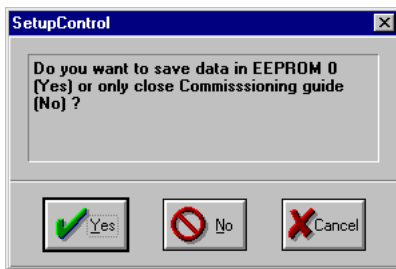

After completing the guided commissioning, you can carry out any controller function using WinBASS. If you want to exit the program, press ALT + F4 or click in the "File" pull-down menu on "Exit".

6.2.4 Speed control by means of analog input 1

In the following parameterisation extensions are described which are required to operate the V-controller as a standalone device without WinBASS as speed controller. The setpoint is entered via the analog input 1.



NOTE

Commissioning has been carried out and motor and encoder setting has been completed.

- **Extending the wiring of X26**

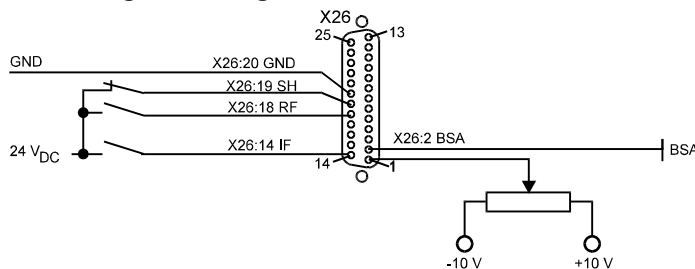

Commissioning

Establishing the link

To determine the setpoint source for speed control, a "link" must be established between the analog input 1 and one of the setpoint inputs of the ramp function generator (see **Ramp Function Generator** on page 167).

Click on "set value generators" in the "Drive mode" pull-down menu.

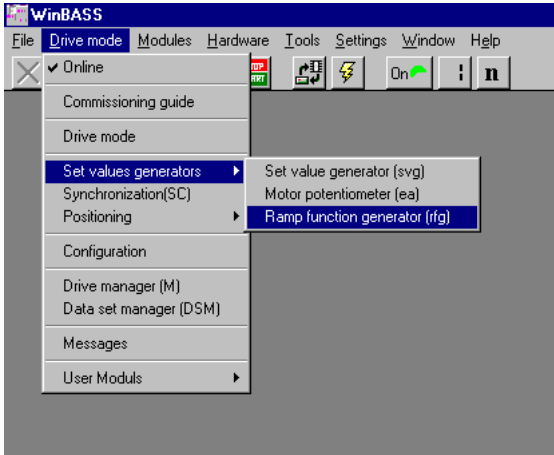

In the submenu select the menu item "Ramp function generator" and the programming window of the ramp function generator opens.

Displace the switching element at the ramp function generator output to select the desired input of the ramp function generator (the example below shows input 1).

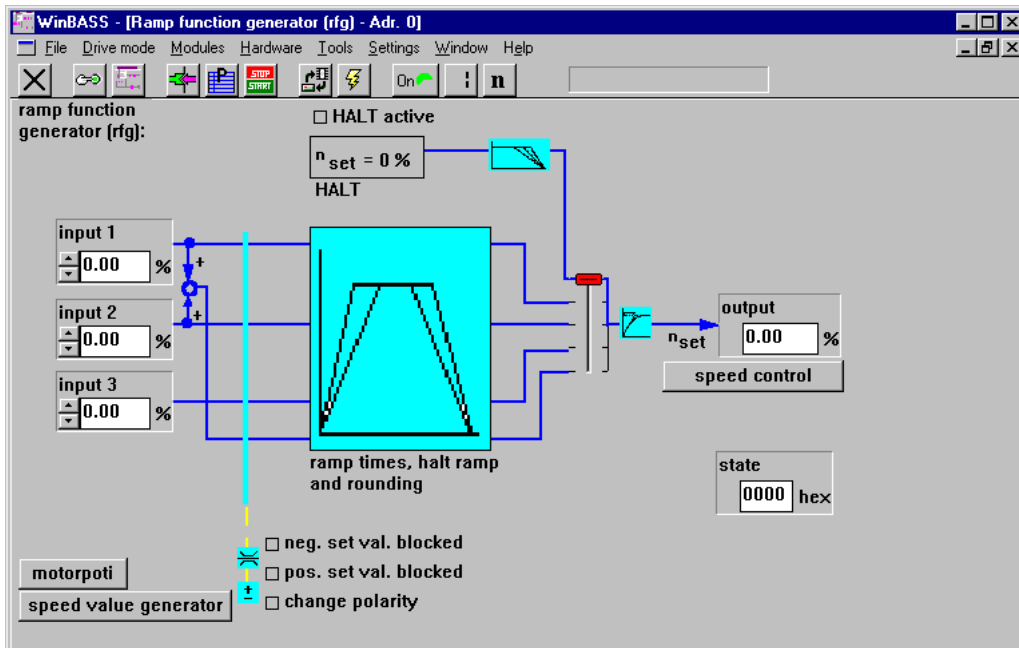

Open the toolbox "Connections" to link analog input 1 with input 1 of the ramp function generator. For this, select "Connections" in the "Tools" pull-down menu.

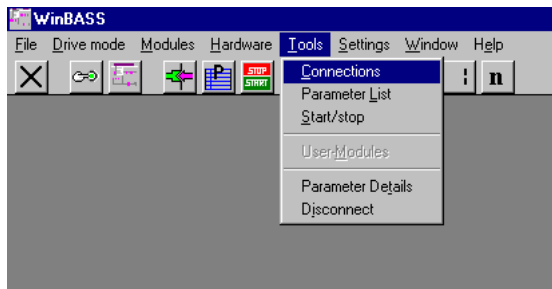

Another window is opened using which you can establish links by drag & drop.

Connections		
Analg In 1	Analg In 2	Analg Out 1
Analg Out 2	LED 1	LED 2
LED 3	LED 4	Digital In 1
Digital In 2	Digital In 3	Digital In 4
Digital Out 1	Digital Out 2	Digital Out 3
N. V. Gen.	Motor-poti	

Click on the "Analog Input 1" button (the cursor changes) and then on input 1 of the ramp function generator. The link has been established now (you can recognise it by the highlighted ramp function generator 1 and the grey background of the button in the toolbox) and the "Analog input 1 (AI1)" screen is displayed automatically.

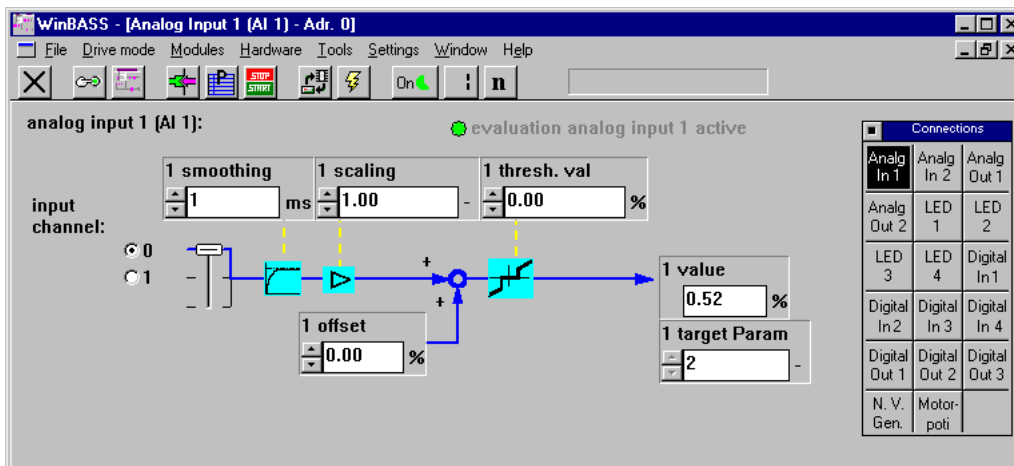

Check the settings of this screen (for a detailed description of analog input 1 see **Analog Inputs** on page 177) and close the screen by clicking on the button "Close actual" in the menu bar.

The extension of the parameterisation of the V-controller is completed now and the function can be tested.

Commissioning

For this, select the menu item "Drive manager" in the "Drive mode" pull-down menu.

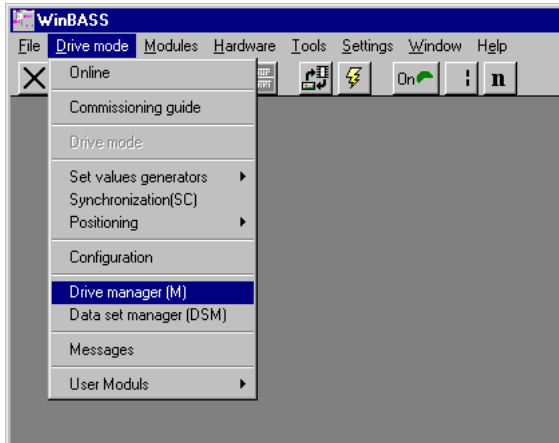

The window of the drive manager opens.

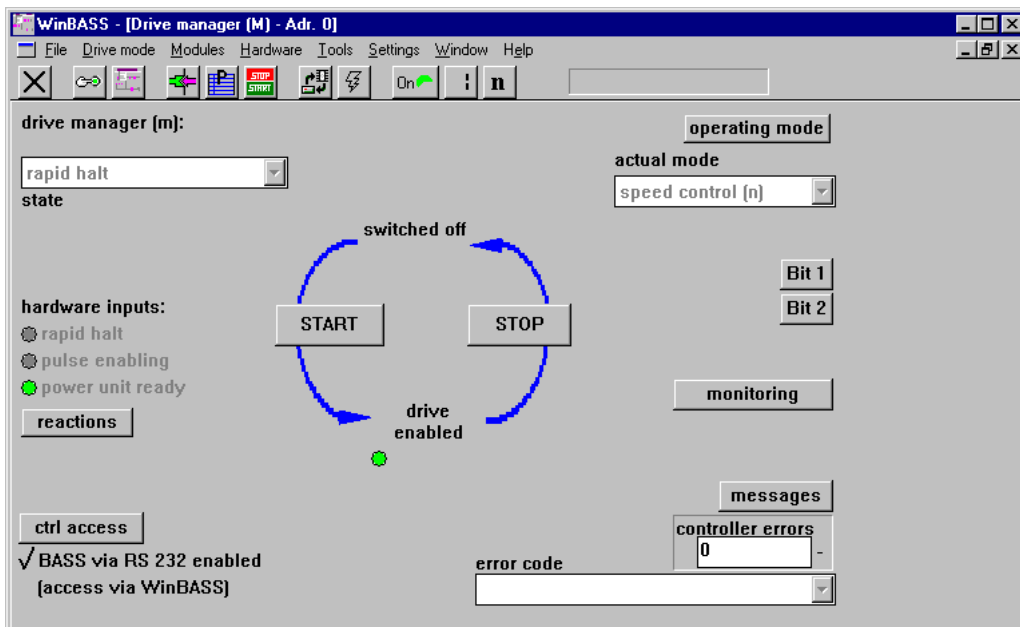

Connect the hardware enables (inputs) and start the drive by clicking on the "Start" button. The motor rotates with the speed which results from the value set at the analog input. To stop the drive, click on the "Stop" button.

Setting the communication source



NOTE

To operate the V-controller as a standalone device, the control access (communication source) via RS232/BASS must be disabled. Otherwise, the V-controller expects control commands from WinBASS.

For this, select the menu item "Drive manager" in the "Drive mode" pull-down menu.

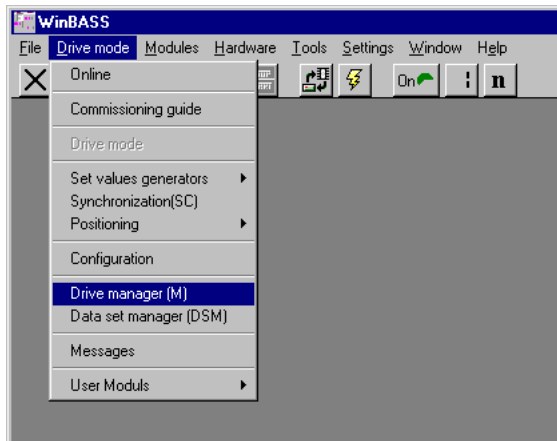

The window of the drive manager opens.

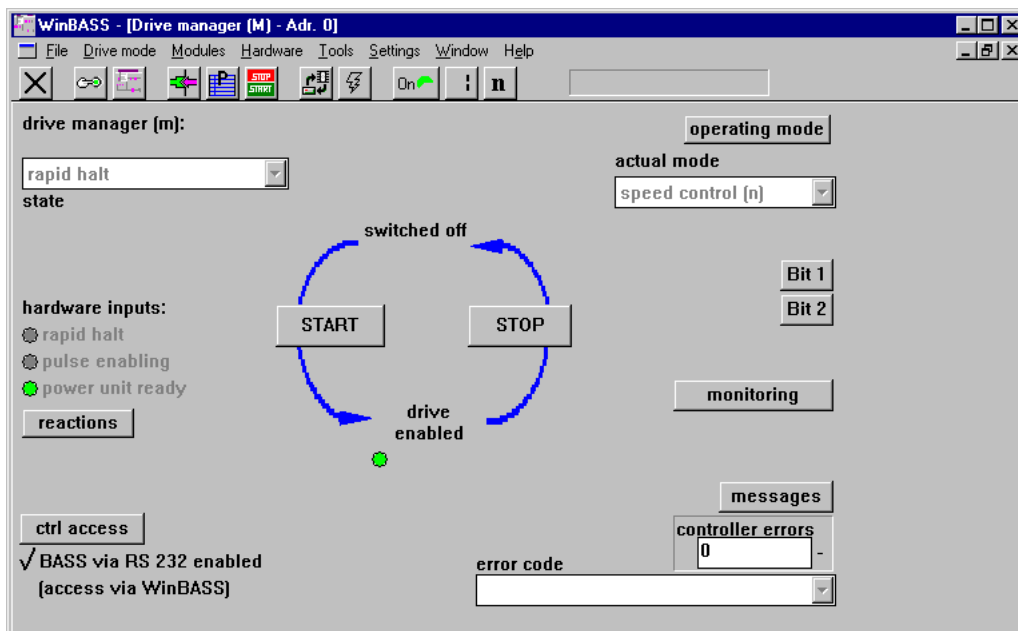

The control access via RS232/BASS is currently enabled. Click on the tick to disable this function.

You close this screen and return to the previous screen by clicking on the "Close actual" button in the menu bar.

To prevent data from getting lost, save the data record (see "Saving data" auf Seite 56) before switching off the controller.

Once you have carried out all changes described above, the drive also operates without WinBASS as described, after you have set the hardware signals.

Saving data

To prevent data from getting lost, save it in the non-volatile controller memory before you switch off the controller.

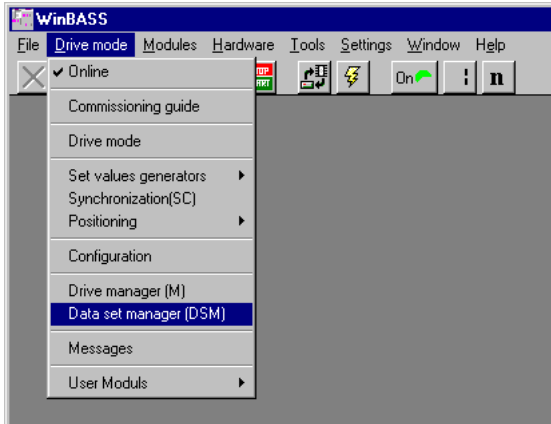

For this, select the menu item "Data set manager (DSM)" in the "Drive mode" pull-down menu. The "Data set manager" screen is displayed.

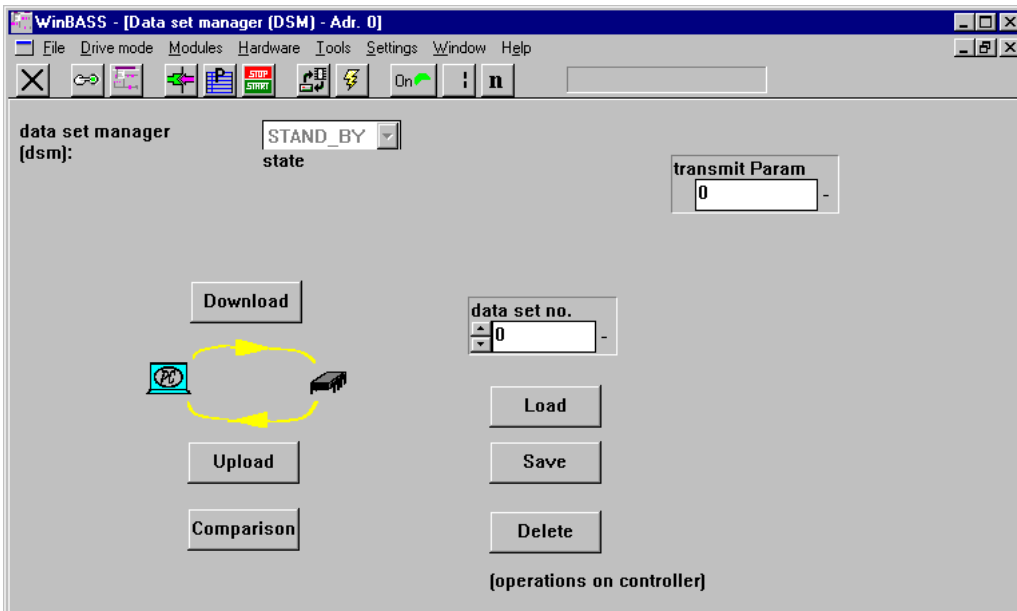

To save the data, click on the "Save" button and the parameters are saved in data record 0 (boot data record = data record which is loaded when the controller is switched on). After the successful saving a confirmation window is displayed. Please close this window by clicking on the "OK" button.

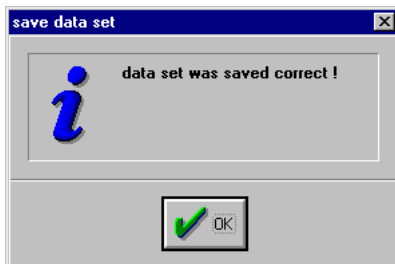

6.3 Locating Position Reference Point Setting

If you do not know the encoder's installation position, you must carry out reference point setting

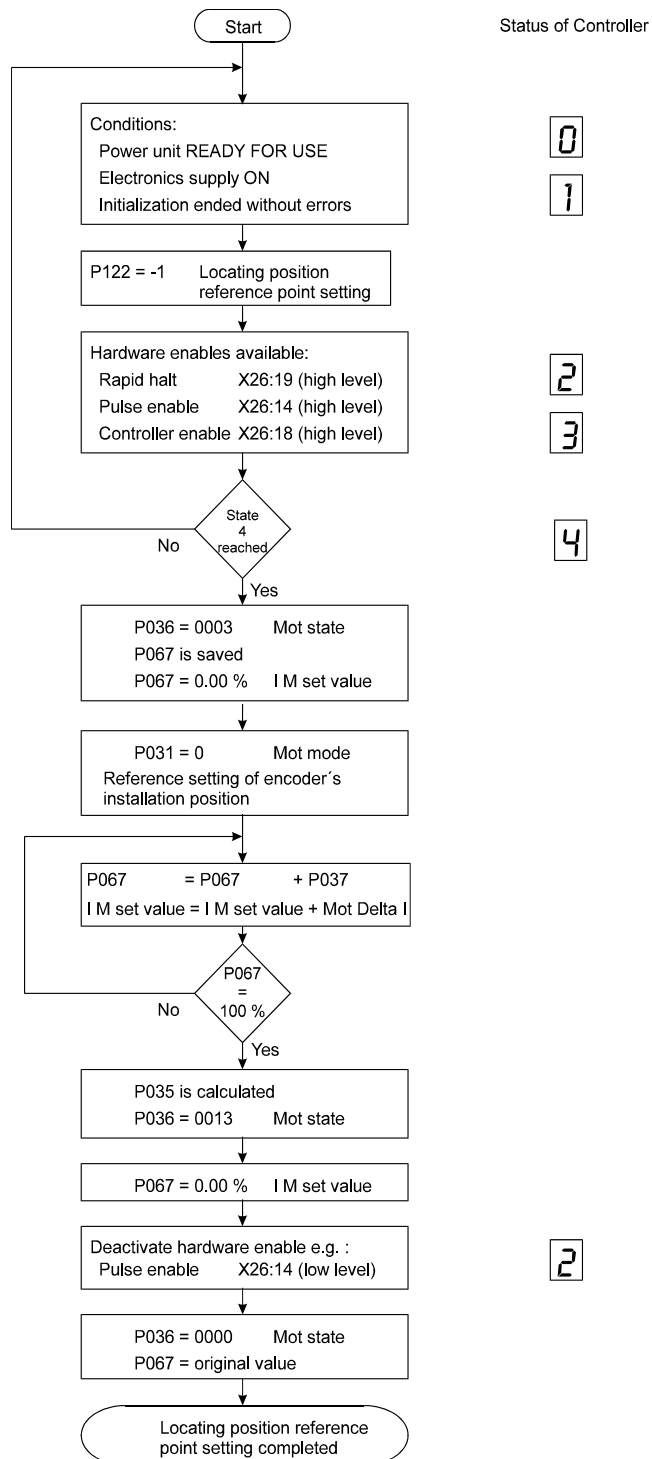

6.4 Commands to Start the Drive

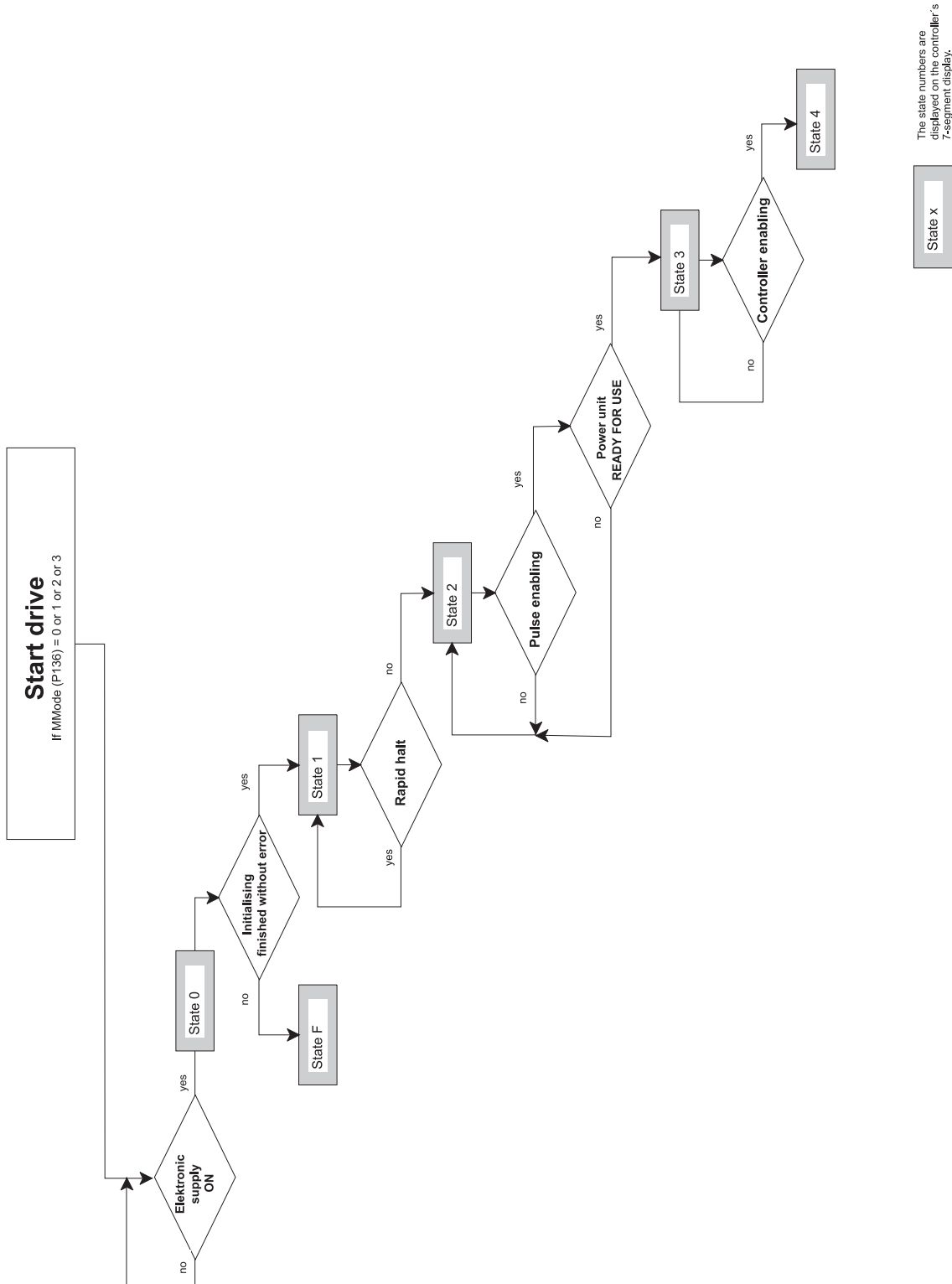

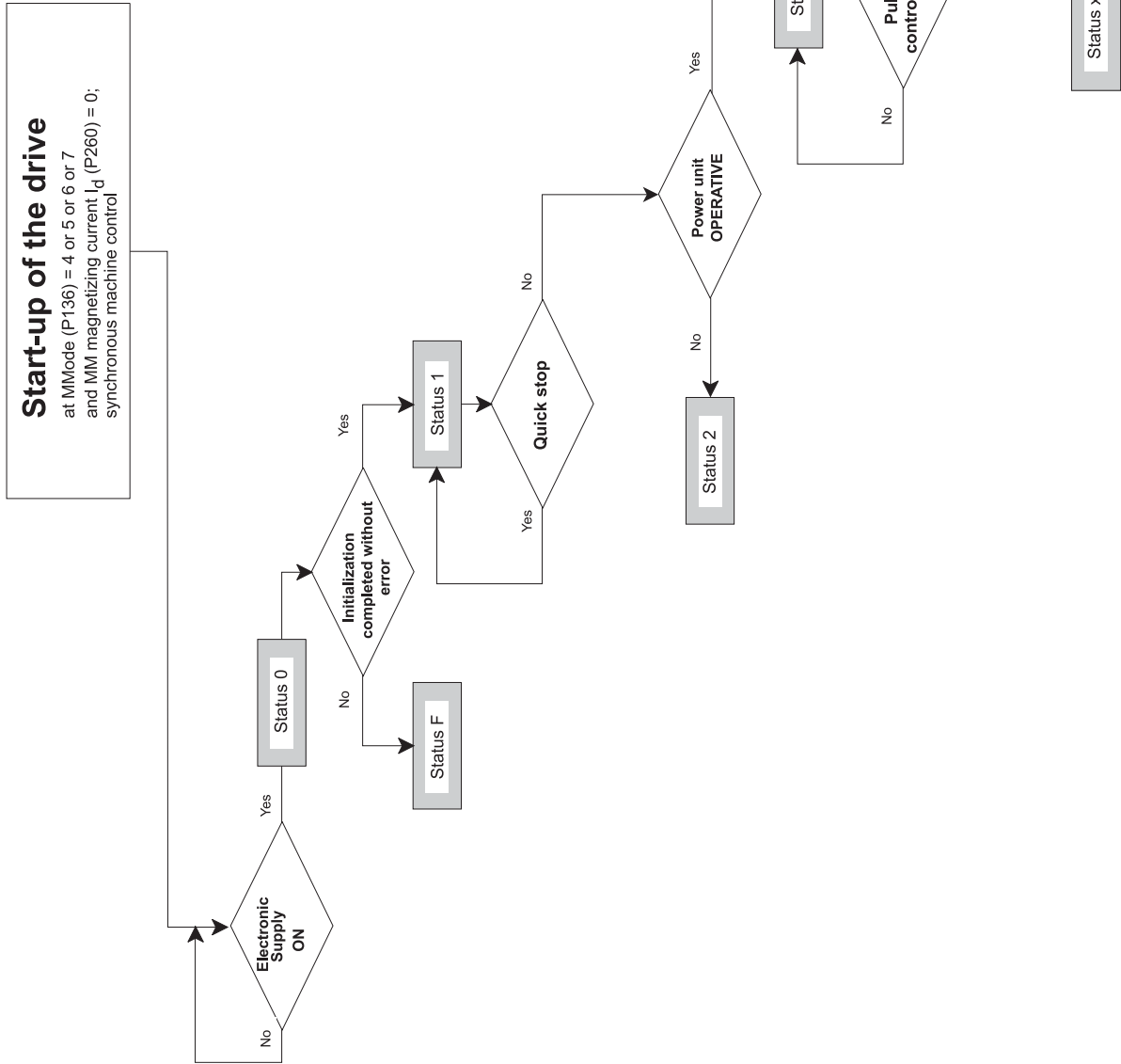

6.5 Commands to Stop the Drive

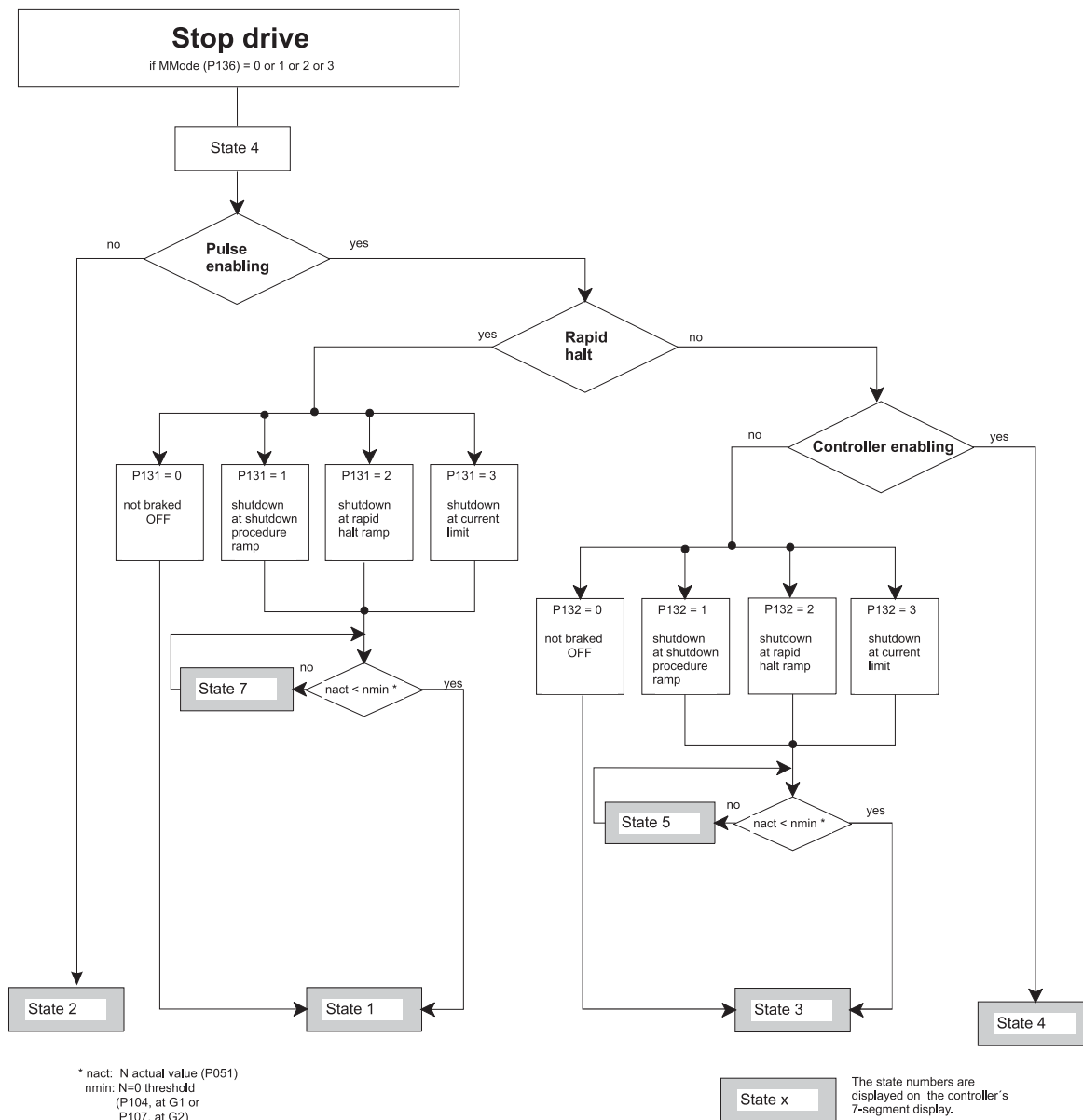

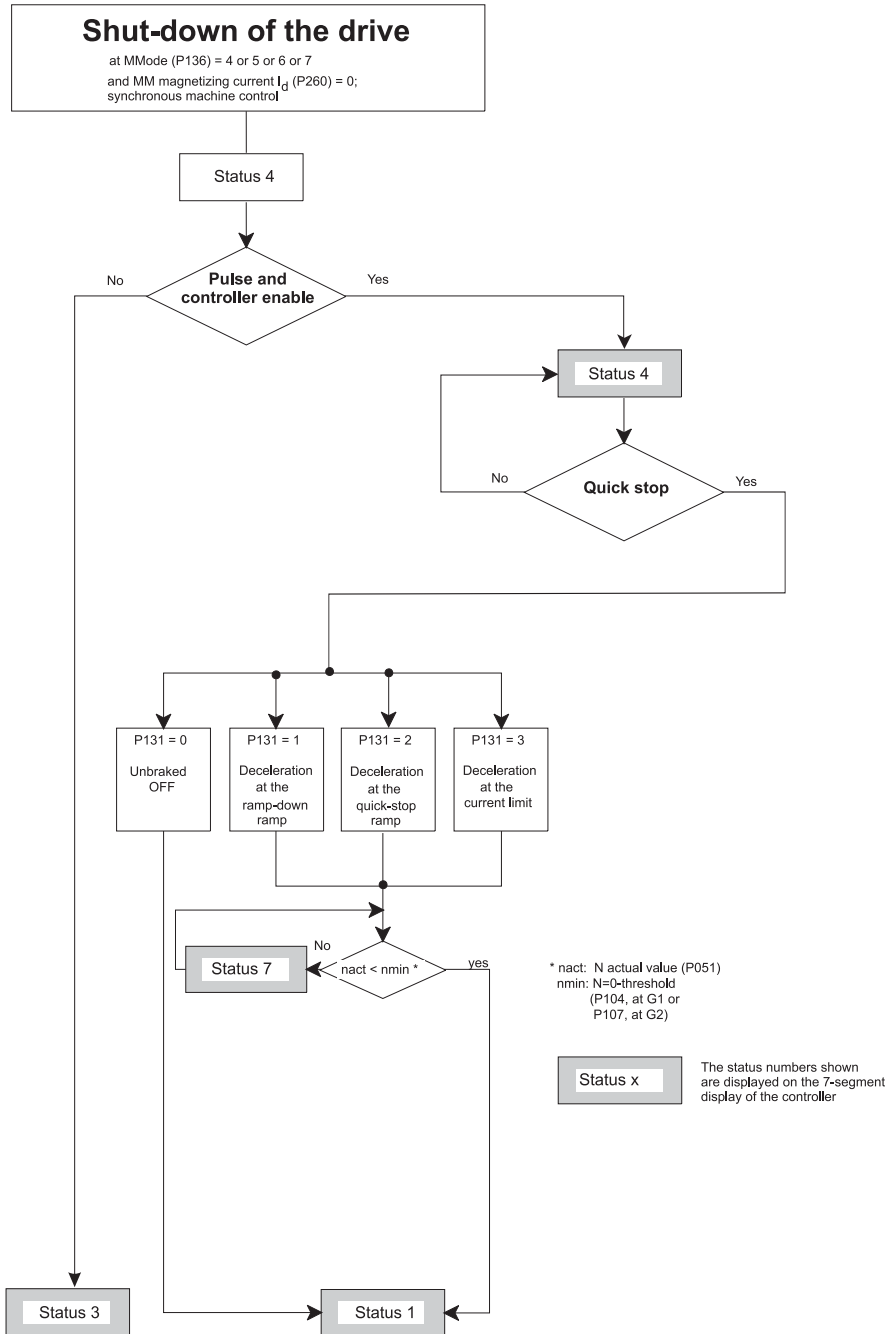

7 PARAMETERS

7.1 Function Diagrams

Encoder Evaluation

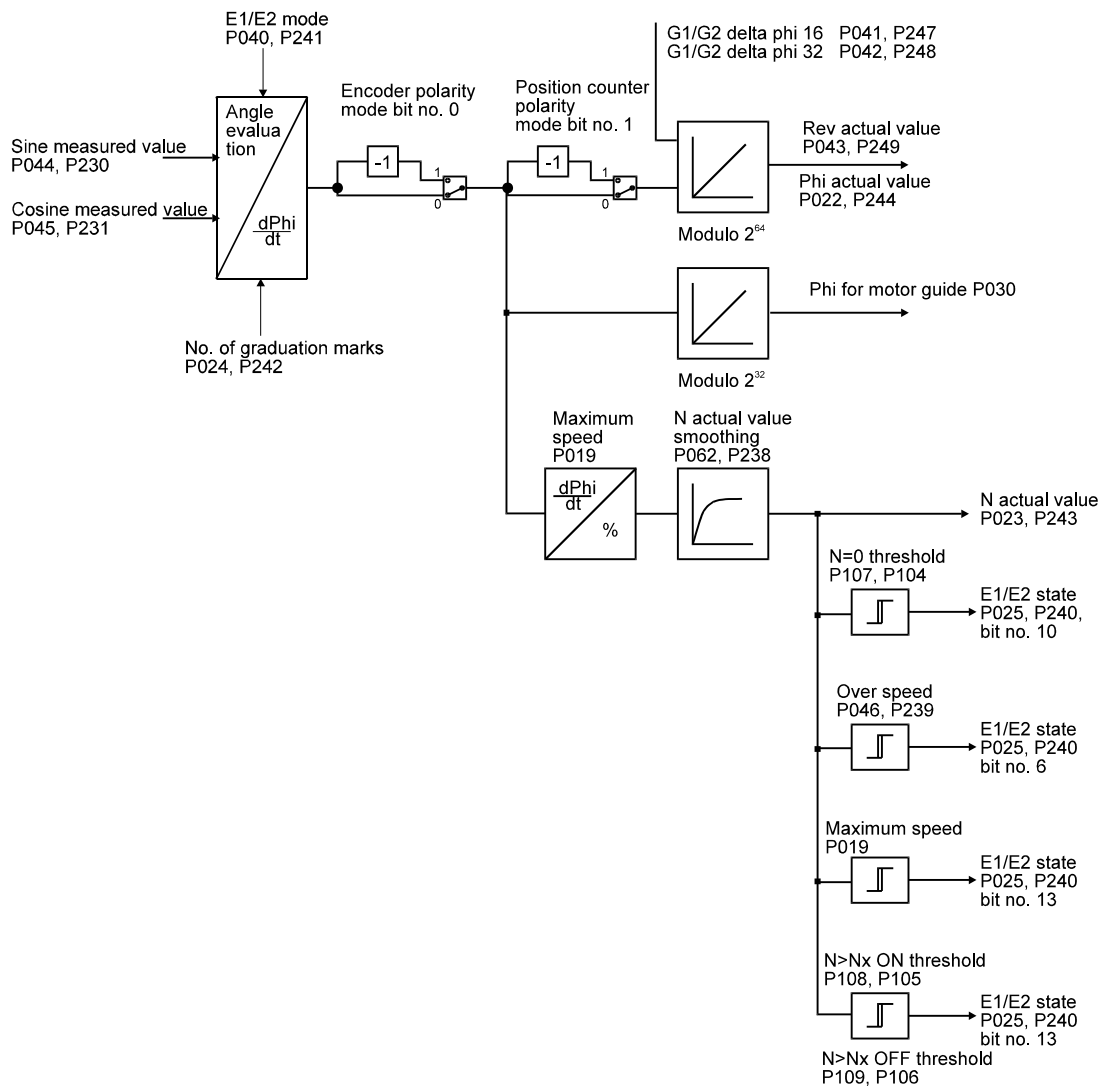

Overview V-Controller

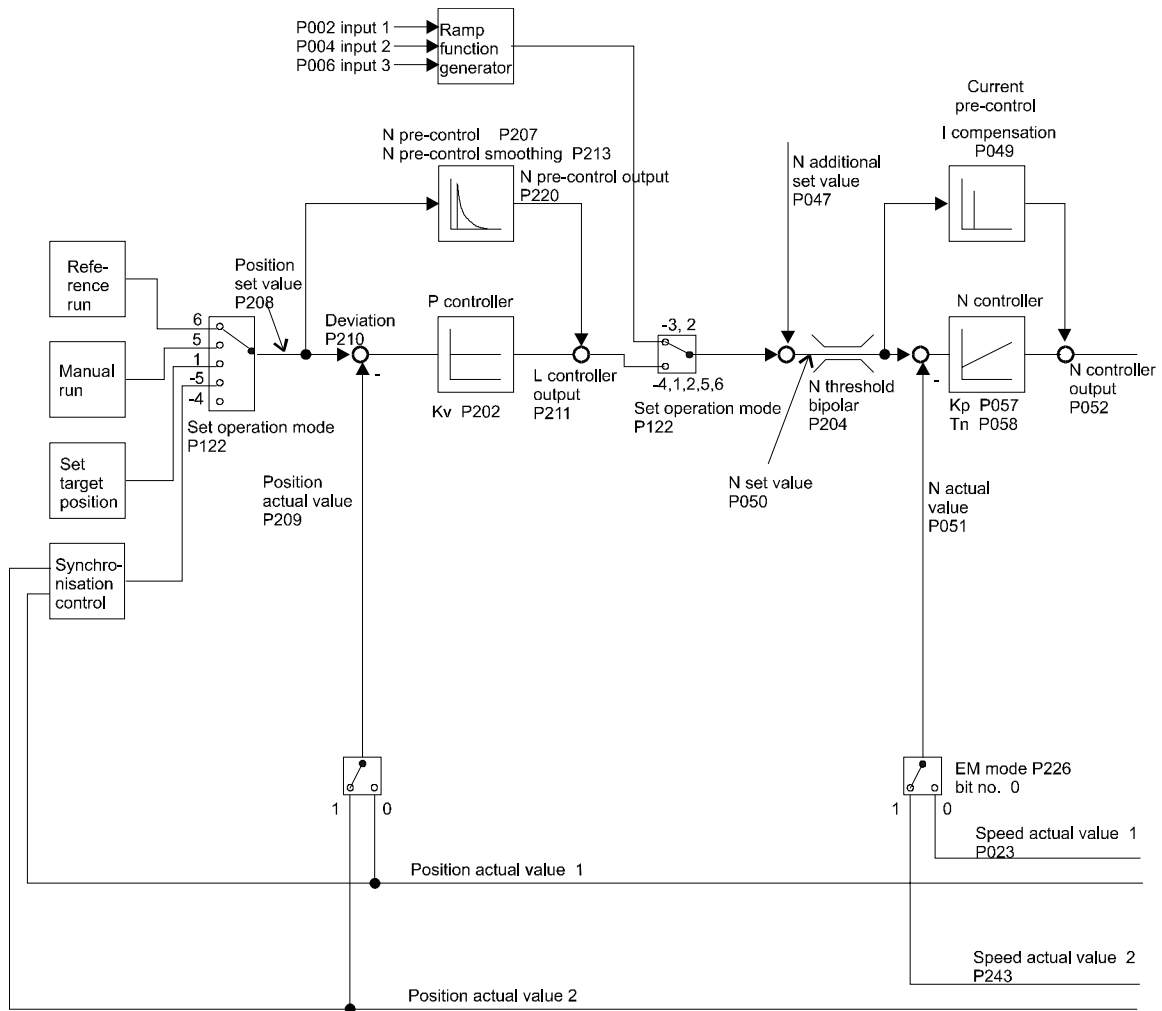

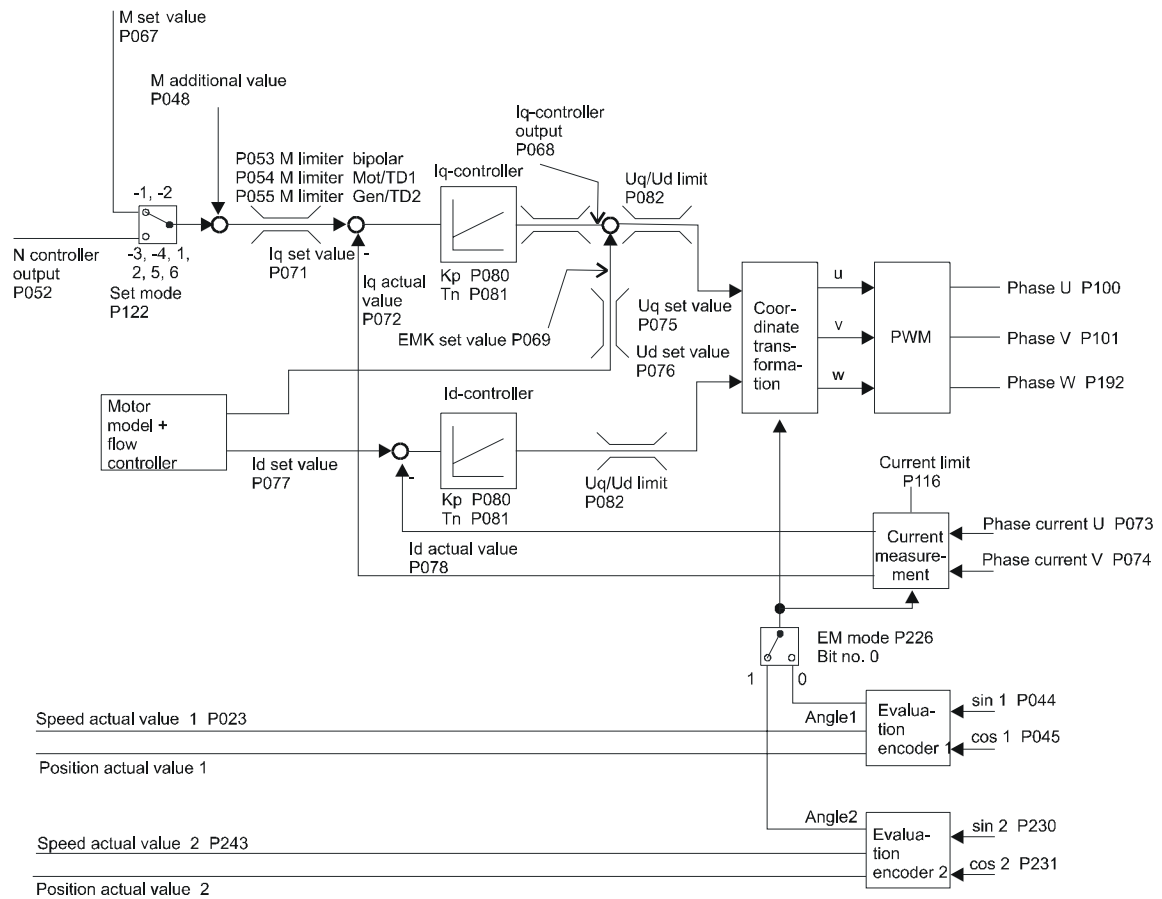

7.2 Power Supply

Function

The function module indicates the status of the power supply unit and the intermediate circuit. Moreover the function voltage failure compensation and intermediate circuit monitoring is implemented.

Parameter overview

Parameter	Name	Range min. ... max.	Unit	Display only
P110	PS state	0000 ... FFFF		×
P087	PS U_{ZK} nominal	280 ... 1000	V	
P111	PS voltage U_{zk}	117 ... 1000	V	×
P112	PS voltage failure time	0 ... 6.000	s	

Parameter description

P110 PS state

This parameter indicates the present power supply state.

Bit no.	Meaning
0 ... 2	0 : STOP Ready for use signal power supply is not monitored 1 : RUN Ready for use signal power supply is monitored 3: STAND BY State after status transition 3 in drive manager. The time to load the intermediate circuit is considered. After maximal 10 s the ready for use signal of the power supply must be available, otherwise the fault 0110 is created.
3	1 : Fault in function module, fault code see M fault code (P124)
4	reserved
5	1 : Warning voltage failure
6	1 : Ready for use signal of power supply is available
7 ... 15	reserved

P087 PS U_{zk} nominal

This parameter sets the nominal intermediate circuit voltage of the power unit.

$$U_{ZK} = U_{Mains} \cdot \sqrt{2}$$

U_{Mains} : voltage between lines

P111 PS voltage U_{zk}

This parameter displays the actual intermediate voltage in V.

P112 PS voltage failure time

Within this time an automatic restart of the drive after a voltage failure is possible.

Value	Meaning
= 0	automatic start not possible
> 0	automatic start possible

In case of a voltage failure the following sequence will start:

The voltage failure is acknowledged by the power supply unit and its disabled status is relayed to the controller by means of the ready for use signal.

The function module power supply recognises this and displays it via bit no. 5 = 1 (warning voltage failure) to the drive manager, and starts a timer, set with the aforementioned time.

The drive manager changes from the status OPERATION ENABLED to the status SWITCHED ON, whereby the method by which this is achieved (see function module drive manager) is set via the parameter M INHIBIT code (P132).

The drive manager remains in the state READY TO START until:

either

the set voltage failure time has expired. After which the function module power supply registers a fault and the drive manager changes to the status FAULT.

or:

the main voltage returns before the end of the voltage failure time. If this occurs the power supply unit resets the signal ready for use (see documentation on power supply unit). The function module power supply acknowledges the new status and reacts by setting bit no. 5 to 0 (warning disabled). The drive manager returns again to the status OPERATION ENABLED and the drive ramps-up automatically.

It is assumed that the controller electronics are supplied with voltage during the voltage failure time!

7.3 Power Unit

Parameter overview

Parameter	Name	Range min. ... max.	Unit	Display only
P115	PU state	0000 ... FFFF		×
P090	PU mode	0000 ... 0007 from SW 04.09 0000 ... FFFF		
P117	PU type	0.1 ... 65535		×
P114	PU I nominal	0.1 ... 2500,0	A	×
P113	PU I max	0.1 ... 2500,0	A	×
P119	PU overload time	0.00 ... 600,00	s	×
P116	PU I limit	The range depends on the PU. Permitted range: $\frac{PU\ I_{nom}}{4} \leq PU\ I\ limit \leq PU\ I\ max$	A	
P118	PU temperature	-80 ... 130	°C	×

Parameter description

P115 PU state

This parameter displays the state of the power unit

Bit no.	Meaning
0 ... 2	0 : STOP 1 : RUN
3	1 : Error in function module, error code see M error code (P124)
4	1 : Power unit reset is active
5	1 : Pulses are enabled, power unit is active
6	1 : Power unit temperature > 80 °C
7	1 : Power unit ready for use
8	1 : PU monitoring is active, current reduction to 100% I _{nom} power unit
9	1: Short circuit temperature sensor
10	1 : "Fault safety relay" is active. The bit does not display the state of the safety relay itself, it displays the stored state "fault safety relay" in the power unit.
11 ... 15	reserved

P090 PU mode

The parameters P114, P113 and P119 can only be changed, if PU Mode 0001_{hex} is set and the password is correct.

Bit-Nr.	Bedeutung
0	0 : Read the power unit's characterisation, data is set according to the characterisation 1 : Characterization is not read, PU data is read from EPROM
1	Short circuit monitoring temperature sensor 0 : If the temperature falls below the threshold value of -40°C the error bit in the PU status is set and the controller is disabled. 1 : If the temperature falls below the threshold value of -40°C only the warning bit No. 9 in the PU status is set. The controller is not disabled.
2	0 : The reaction on "Fault safety relay" is equal in all controller states. 1 : Reaction on "fault safety relay" depends on controller state: No error 0206_{hex} is displayed when "fault safety relay" appears in states 0 (NOT READY TO START), 1 (INHIBIT START), 2 (READY TO START) and F (FAULT). The error 0210_{hex} is not generated in this states too. In the states 3 (SWITCHED ON), 4 (OPERATION ENABLED), 5 (INHIBIT OPERATION ACTIVE), 6 (SHUTDOWN ACTIVE), 7 (RAPID HALT ACTIVE) and E (FAULT REACTION ACTIVE) only the error 0206_{hex} is displayed when the safety relay reacts. The errors 0204 _{hex} and 0207 _{hex} to 020D _{hex} which follow are not displayed.
3	reserved
4 ... 5	from SW 14.09 Multiple scanning of the ready-for-use signal before changing to the error state when the ready-for-use signal is missing: 00: 10 times controller displays after 320 ms the missing ready-for-use signal with an error message (standard, setting for error-free operation) 01: 7 times controller displays after 224 ms the missing ready-for-use signal with an error message 10: 4 times controller displays after 128 ms the missing ready-for-use signal with an error message 11: 2 times controller displays after 64 ms the missing ready-for-use signal with an error message
6	from SW 14.09 PU lxt monitoring: current reduction when reaching 100 % of lxt value (P139) 0: reduction to P114 PU I nominal standard 1: reduction to P261 MM motor nominal current *)
7 ... 15	reserved

*) Notes referring to Bit 6:

In addition to the present functions with the parameter P090 PU mode bit no. 6 = 1 a reduction to the motor nominal current (P261 MM motor nominal current) can be set. Therefore the motor nominal current must be set smaller than the power unit nominal current.

To avoid a pump effect (permanent enable and disable of the current reduction) the second condition for enabling the limit current again is P056 N blocking time. After the blocking time is over the reduction is disabled at the earliest.

Warning:

- If P116 PU I limit is set lower than the power unit nominal current, the lxt monitoring never reduces the current.
- If P116 PU I limit is set lower than the PU I_{max}, the period running the machine with PU I limit is enlarged according to the current time area.
Example: BUS621-10/15A; (15 A - 10 A) * 1 s = (12,5 A - 10 A) * 2 s
- When accelerating the first time (cold power unit) the motor can be run with the PU I max current not exceeding the overload time. For normal units the overload time is 1 s. Only the large units e.g. BUM 62, BUM63 and BUM 64 permit an overload time of 120 s.

P117 PU type

The parameter displays the type of the power unit. The value 0 characterizes an unknown power unit.

Version	Power unit	PWM frequency P103 = 8 kHz nominal/peak cur- rent effective	PWM frequency P103 = 4 kHz nominal/peak cur- rent effective	Overload time in s
6210	BUS621	5 A / 7,5 A	6,3 A / 7,5 A	1
6211	BUS621	10 A / 15 A	12,5 A / 15 A	1
6212	BUS621	3 A / 3,7 A	3,1 A / 3,7 A	1
622	BUS622	15 A / 22 A	18,3 A / 22 A	1
623	BUS623	20 A / 30 A	25 A / 30 A	1
6240	BUS624	38 A / 57 A	47,5 A / 57 A	1
6241	BUS624	45 A / 67,5 A	56,3 A / 67,5 A	1
600	BUM60	12 A / 24 A	12 A / 24 A	1
601	BUM60	6 A / 12 A	6 A / 12 A	1
602	BUM60	3 A / 6 A	3 A / 6 A	1
612	BUM61	24 A / 45 A	30 A / 45 A	1
613	BUM 61	32 A / 60 A	40 A / 60 A	1
62	BUM62	57,7 A / 75 A	75 A / 97,5 A	120
6203	BUM62T	75 A / 97 A	100 A / 130 A	120
6201	BKH62	75 A / 97,5 A	90 A / 97,5 A	1
63	BUM63	115 A / 150 A	150 A / 195 A	120
6301	BKH63	150 A / 195 A	180 A / 195 A	1
6302	BUM63T	210 A / 235 A	160 A / 180 A	120
64	BUM64	231 A / 300 A	300 A / 390 A	120

How to change the power unit data in case of an unknown power unit, see below:

PU mode = 0001_{hex} P090

DSM command = 0 P190

DSM command = 8 P190

Enter password 1

Parameter P013, P114 and P119 can now be set and the PU characterization is not be read at booting.

Values for peak current (P115), nominal current (P114) and overload time (P119) see table above.

PU I max = set table value P113

PU I nominal = set table value P114

PU overload time = set table value P119

PU I limit = set value P116

DSM command = 0 P190

DSM command = 5 P190

→ Values are stored in the EEPROM

The data of the power unit is available now on every switch on.

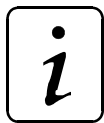

NOTE

After each change of parameter P103 (PWM) the data must be saved, the controller switched off and booted new to set the new power unit parameters.

P114 PU I nominal

This parameter displays the power unit's nominal current. This current can be supplied for an unlimited time.

P113 PU I max

This Parameter shows the power unit's peak current. The peak current is greater or equal power unit nominal current.

P119 PU overload time

During the overload time the power unit can supply the peak current. After that the nominal current (P114) is limited. The bit no. 8 in PU state (P115) displays the limitation.

P116 PU I limit

This parameter sets the standardization of the current controlling.

Standardization

100 % ↔ I limit

The limits of this parameter depend on the power unit used.



NOTE

The standardization of the current controlling must not be changed if pulses are enabled.

P118 PU temperature

This parameter displays the power unit's temperature.

A temperature over 80°C enables the bit no. 6 in PU state (P115). Exceeds the power unit's temperature 85°C the error 0205_{hex} appears.

7.4 Overload Monitoring of Power Unit

This monitoring protects the power unit from thermic overload. The temperature of the power unit is imitated and monitored by a Ixt model.

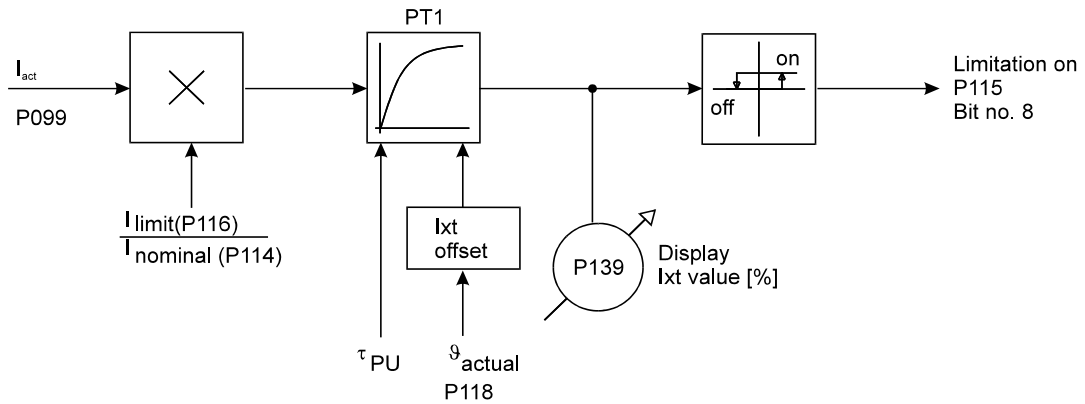

Parameter overview

Parameter	Name	Range min. ... max.	Unit	Display only
P139	PU Ixt value	0,00 ... 400,00	%	×

Parameter description

P139 PU Ixt value

This parameter displays the actual I*t value of the overload monitoring. At a value equal 100 % follows a current limitation to nominal current (P114). Drops the I*t value below 95% the current value is set to PU I limit (P116).

Current set value	(I _{act}) [A _{eff}]	P099
PU nominal current	(I _{nom}) [A _{eff}]	P114
PU maximum current	(I _{max}) [A _{eff}]	P113
PU limit current	(I _{limit}) [A _{eff}]	P116
PU overload time	(t _o) [s]	P119
PU temperature	(θ _{act}) [°C]	P118
PU Ixt value	(Ixt) [%]	P139
PU overload factor max	(u _{max}) [%]	
PU overload factor actual	(u) [%]	
PU thermic time constant	(τ _{PU}) [s]	
PU reaction time	(t _{rea}) [s]	time till the limitation of I _{nom}
PU Ixt offset	(Ixt offset) [%]	

$$u_{\max} = \frac{I_{\max}}{I_{\text{nom}}} \cdot 100 \quad [\%]$$

$$u = \frac{I_{\text{act}}}{I_{\text{nom}}} \cdot 100 \quad [\%]$$

$$\tau_{\text{PU}} = -\frac{t_o}{\ln\left(\frac{u_{\max} - 100}{u_{\max}}\right)} \quad [\text{s}]$$

- for power unit temperature > 45 °C

$$lxt_{\text{offset}} = \frac{\vartheta_{\text{act}} - 45^{\circ}\text{C}}{85^{\circ}\text{C} - 45^{\circ}\text{C}} \cdot 100 \quad [\%]$$

- otherwise
lxt offset = 0 %

$$t_{\text{off}} = \tau_{\text{PU}} \cdot \ln\left(\frac{u - 100}{u - lxt_{\text{offset}}}\right)$$

Example:

$$I_{\text{nom}} = 10 \text{ A}_{\text{eff}} \text{ (BUS 621)}$$

$$I_{\text{max}} = 15 \text{ A}_{\text{eff}} \text{ (BUS 621)}$$

$$t_{\text{u}} = 1 \text{ [s]} \text{ (BUS 621)}$$

$$I_{\text{limit}} = 12 \text{ A}_{\text{eff}}$$

$$\vartheta_{\text{act}} = 35^{\circ}\text{C}$$

$$u_{\text{max}} = \frac{15}{10} \cdot 100 = 150 \quad [\%]$$

$$u = \frac{12}{10} \cdot 100 = 120 \quad [\%]$$

$$\tau_{\text{PU}} = -\frac{1}{\ln\left(\frac{150 - 100}{150}\right)} = -(0,91) \quad [\text{s}]$$

$$t_{\text{off}} = -(0,91) \cdot \ln\left(\frac{120 - 100}{120 - 0}\right) = 1,63 \quad [\text{s}]$$

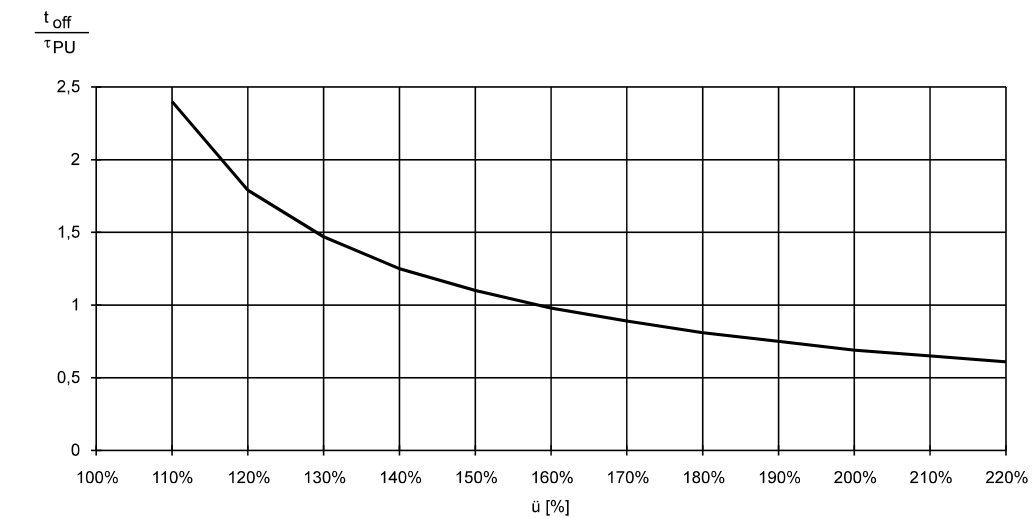
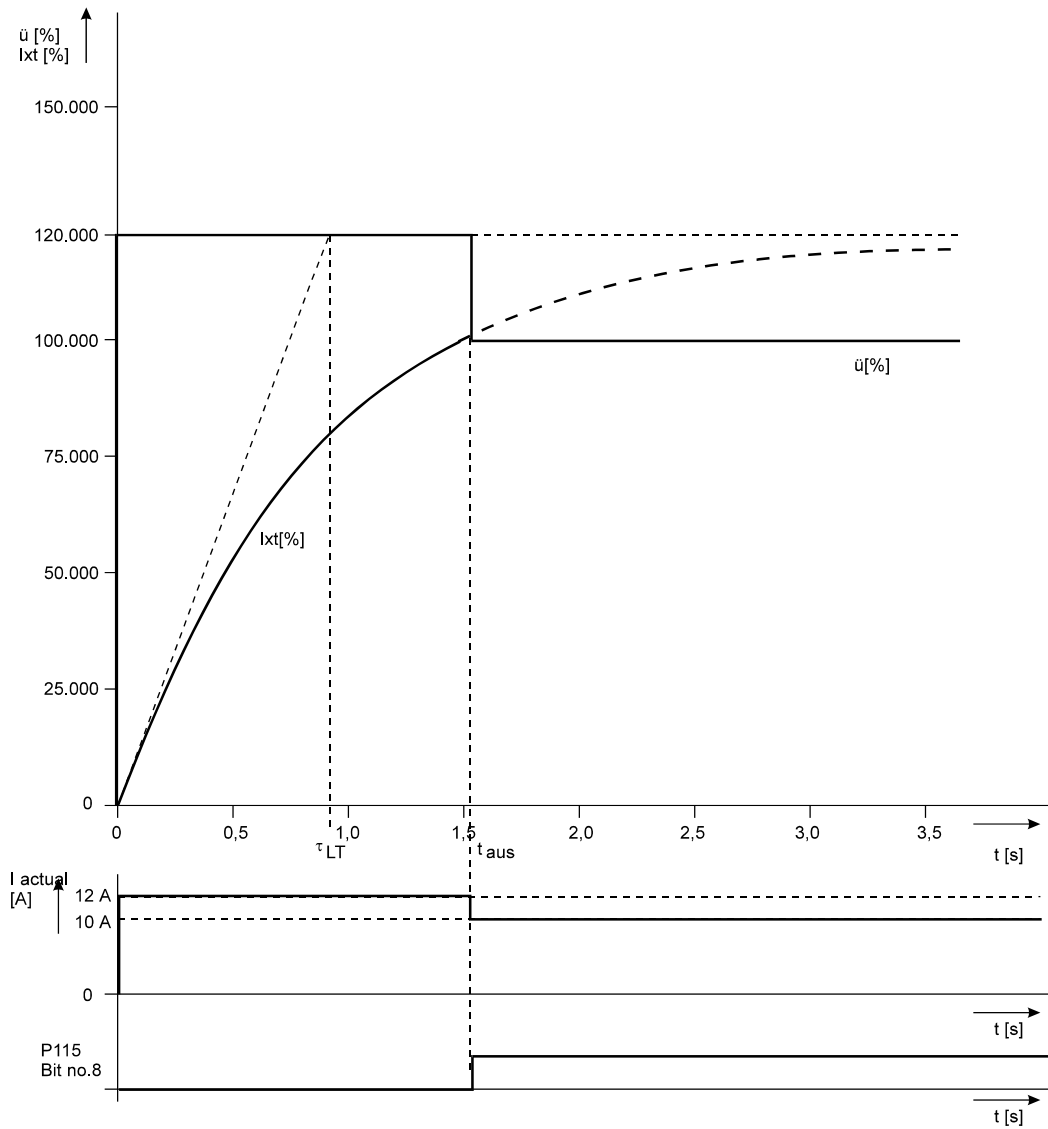

This characteristic curve refers to a „cold“ power unit (I_{xt} Offset = 0 %; $\vartheta_{ist} < 45$ °C).

7.5 Pulse Width Modulation

Function

The parameters of the pulse width modulation module only serve to display the values supplied by the current controller.

Parameter overview

Parameter	Name	Range		Unit	Display only
		min.	... max.		
P100	PWM phase U	-100,00	... +100,00	%	×
P101	PWM phase V	-100,00	... +100,00	%	×
P102	PWM phase W	-100,00	... +100,00	%	×
P103	PWM frequency	4,0	... 8,0	kHz	
P199	PWM mode switch (from V4.xx)	0	... 100	%	

Parameter description

P100 PWM **phase U**

P101 PWM **phase V**

P102 PWM **phase W**

These parameters display the angle α of the relative power transistors for the individual phases.

This means: +100,00 % to a regulation angle of $\alpha = +100\%$
 0 to a regulation angle of $\alpha = 0\%$
 -100,00 % to a regulation angle of $\alpha = -100\%$

The resultant voltage (middle values) at the power supply terminals can be calculated as follows:

$$\overline{U_{UV}} = U_{ZK} \cdot \frac{\text{PWM phase U} - \text{PWM phase V}}{\text{maximum total range}} = P111 \cdot \frac{P100 - P101}{200,00\%}$$

$$\overline{U_{VW}} = U_{ZK} \cdot \frac{\text{PWM phase V} - \text{PWM phase W}}{\text{maximum total range}} = P111 \cdot \frac{P101 - P102}{200,00\%}$$

$$\overline{U_{WU}} = U_{ZK} \cdot \frac{\text{PWM phase W} - \text{PWM phase U}}{\text{maximum total range}} = P111 \cdot \frac{P102 - P100}{200,00\%}$$

Whereby U_{ZK} is the intermediate circuit voltage which is indicated via P111. Due to the underlying cycle frequency this voltage cannot be measured on universal devices.



DANGER

Even with an output voltage close to zero, the pulsed intermediate circuit voltage is detectable at the terminals. In addition a potential of > 300 V to earth may be detected at the terminals.

P103 PWM frequency

The frequency of the power unit is normally 8,0 kHz and can be changed to 4,0 kHz (values between are not possible).

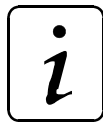

NOTE

A change of the frequency is only permitted when pulses are inhibited.
After change of the frequency the parameter must be stored and the controller has to be rebooted!

P199 PWM mode switch

With this parameter you can switch between space phasor modulation (SPM) and modified SPM (MSPM).

When using modified SPM the average switching frequency is reduced by one third and therefore the average switching loss is reduced by one third, too. Using the MSPM has advantages especially at higher load (>80 %).

At lower load the switching loss is reduced by one third as well, but the ripple of the switching current can be twice of that with normal SPM.

Therefore this parameter should be set between 80 % and 100 %.

7.6 Motor Model

Function

This function module sets the parameters for synchronous and asynchronous machine.

Parameter overview synchronous and asynchronous machine

Parameter	Name	Range min. ... max.	Unit	Display only
P260	MM magnetizing current I_d	0,0 ... P116	A	
P261	MM motor nominal current	•	A	
P264	MM Kp flux controller	0,2 ... 15,9		
P265	MM Tn flux controller	0,0 ... 1000,0	ms	
P268	MM Ke factor	0 ... 400	V/1000	
P269	MM mode	0000 ... 001F from SW 14.09 0000 ... 00FF		
P298	MM stator resistance (from V4.xx)	0,000 ... 65,535	Ω	
P299	MM leakage inductance (from V4.xx)	0,00 ... 653,35	μ H	

Parameter overview asynchronous machine

Parameter	Name	Range min. ... max.	Unit	Display only
P293	MM Tr rotor actual value	0 ... 20000	ms	×
P266	MM flux set value	0 ... 100	%	×
P267	MM flux actual value	0 ... 100	%	×
P262	MM nominal speed	1 ... 11500	rpm	
P294	MM frequency temperature 1	up to SW 14.07 10,00 ... P263 from SW 14.08 10,00 ... 600,00	Hz	
P295	MM temperature 1	up to SW 14.07 -30 ... P296 from SW 14.08 -30 ... 230	$^{\circ}$ C	
P263	MM nominal frequency	up to SW 14.07 P294 ... 600,00 from SW 14.08 10,00 ... 600,00	Hz	
P296	MM temperature 2	up to SW 14.07 P295 ... 230 from SW 14.08 -30 ... 230	$^{\circ}$ C	
P297	MM frequency = f (temp)	10,00 ... 600,00	Hz	×
P291	MM MGen1 Nnominal	0 ... 100	%	
P292	MM MGen2 12000 rpm	0 ... P291	%	
P303	MM Kp field weakening (from V4.xx)	0,2 ... 15,9		
P304	MM Tn field weakening (from V4.xx)	0,0 ... 1000,0	ms	

- Minimal value = 10 % of nominal current of the power unit
Maximum value = peak current of the power unit (see parameter P117 LT version)

Parameter description for synchronous and asynchronous machines

P260 MM magnetizing current I_d **SM:**

A field weakening is implemented for the SM. If the output voltage reaches the value of $U_{zk}/(\sqrt{2})$ the the field weakening starts. The I_d set value is limited between 0 and 50 % of the power units nominal current (P114). This can increase the speed between 10 and 20 %.

MM mode bit no. 3 = 0 (SM) P269

MM magnetizing current I_d range 0 $\frac{PU I \text{ nom (P114)}}{2}$ P260

MM T_n field controller $T_n = \frac{2}{6 \cdot f_1}$ P265

f_1 : first harmonic at the start of the field weakening

MM k_p field controller = 2 ... 3 P264

AM:

MM mode bit no. 3 = 1 and bit no. 4 = 1 P269

See I_d from motor data sheet

If I_d is not known, it can be calculated approximately

$$I_d = |I| \cdot \sqrt{1 - (k \cdot \cos \varphi_n)^2}$$

It is: $|I|$ = motor nominal current (P261)
 $\cos \varphi_n$ = $\cos \varphi$ motor in nominal load (see type code)
 $k = 1,0 \dots 1,3$

P261 MM motor nominal current

This parameter sets the motor nominal current. Moreover it is used to calculate the overload factor of the motor I^2t monitoring.

$$\text{Overload factor} = \frac{I_{\text{limit}}(\text{P116})}{\text{Motor nominal current (P261)}}$$

P264 MM K_p flux controller

This parameter sets the gain (K_p) of the flux controller.

AM: $K_p = 3 \dots 6$

SM: $K_p = 2 \dots 3$.

P265 MM T_n flux controller

This parameter sets the integral action time (T_n) of the flux controller.

AM: $T_n \approx 1/2 \cdot \text{P293}$

SM: $T_n = \frac{2}{6 \cdot f_1}$, f_1 : first harmonic at the start of the field weakening.

P268 MM Ke factor

Here, you set the motor EMF, relative to 1000 rpm (voltage constant), of the synchronous or asynchronous machine.

If no value is available for the Ke factor, you can proceed as follows:

- Set a speed specified value that corresponds to the motor's rated speed (P262)
- Enable the drive and run it at no-load
- By changing Ke (P268), bring the Iq controller output (P068) down to approximately 0%

P269 MM mode

Bit no.	Meaning
0	0 : Follow-up of temperature is switched off 1 : Follow-up of temperature is active
1	0 : Generatoric torque limiting is switched off 1 : Generatoric torque limiting is active
2	0 : If pulse enable and controller enable are activated at the same time, immediate torque release followed within the basic speed range (up to nominal speed P262). Above the nominal speed the torque set value is released after $3 * T_R$. 1 : If pulse enable and controller enable are activated at the same time, the torque will be available after $3 * T_R$.
3	up to version 3.xx : reserved 0 : Synchronous machine (from version 4.xx) 1 : Asynchronous machine (from version 4.xx)
4	up to version 3.xx : reserved 0 : Chopper available, Uz _k controlling switched off, Uz _{k,ref} = 800 V (from V4.xx) 1 : no chopper available, Uz _k controlling active, Uz _{k,ref} = 760 V (from V4.xx) (explanation see Uz _k controlling on next page)
5	reserved
6	upper interpolation point for torque limiting of the asynchronous machine 0 : at 12000 rpm (standard) 1 : at 24000 rpm
7	0 : field weakening depending on voltage (standard) 1 : field weakening with constant I _{sd} current
8 ... 15	reserved

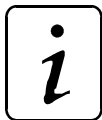

NOTE

Check the locating angle (P035) when switching from asynchronous to synchronous machine.

The function Uz_k controlling is only available for synchronous machines. The Uz_k controlling must be deactivated, if a chopper is available.

Uzk controlling:

The generatoric torque limit is changed depending on intermediate circuit voltage. If the intermediate circuit voltage exceeds the set value, the generatoric torque is reduced. Therefore the controlling of the intermediate circuit voltage is necessary.

Because the switch on threshold of a chopper is approx. 760 V, the Uzk controlling must be deactivated if a chopper exists.

MM mode bit no. 4 is the only parameter for Uzk controlling. The controller parameters are dimensioned and set internal. The controlling is in normal use always stable.

Exceptionally an overshoot of the intermediate circuit voltage can occur, e.g. if the intermediate circuit's capacity is very low and the brake current in the intermediate circuit is very high. In this case the N M limiter type (P038) should set to 0 and the N M limiter Gen/MR2 (P055) should be reduced.

P298 MM stator resistance

P299 MM leakage inductance

To improve the bandwidth of the current controller a current prediction procedure is implemented. The necessary parameter can be set here.

Settings of the current controller:

P298 = 0 oder P299 = 0

The current prediction is switched off, the parameter k_p and T_N can be set as usual.

If the motor parameter stator resistance and leakage inductance are known, the current controller can be set according the instructions at the module current controller.

(See P080 I P gain P081 I integral action time on page 121.)

Parameter description for asynchronous machines

P293 MM Tr actual value

This parameter displays the rotor time constant (T_r) of the asynchronous machine.

P266 MM flux set value

P267 MM flux actual value

This parameter shows the flux actual and set value of the asynchronous machine.

P262 MM nominal speed

The nominal speed can be read on the type label / motor data sheet of the motor.

P263 MM nominal frequency at temperature 2

The nominal frequency at nominal torque can be read on the type label / motor data sheet of the motor. This nominal frequency results in the thermic state of the machine - P296 MM temperature 2 (warm).

P294 MM frequency at temperature 1

P295 MM temperature 1

P296 MM temperature 2

P297 MM frequency = f (temp)

The asynchronous motor's rated frequency is changed; this change is linear in dependence on the motor temperature (P153). As a result of this, there is constant torque across the motor temperature, assuming that the cross current is constantly regulated.

It is: 10,00 Hz ≤ P294 ≤ P263 ≤ 600,0 Hz
 -30°C ≤ P295 ≤ P296 ≤ 230°C

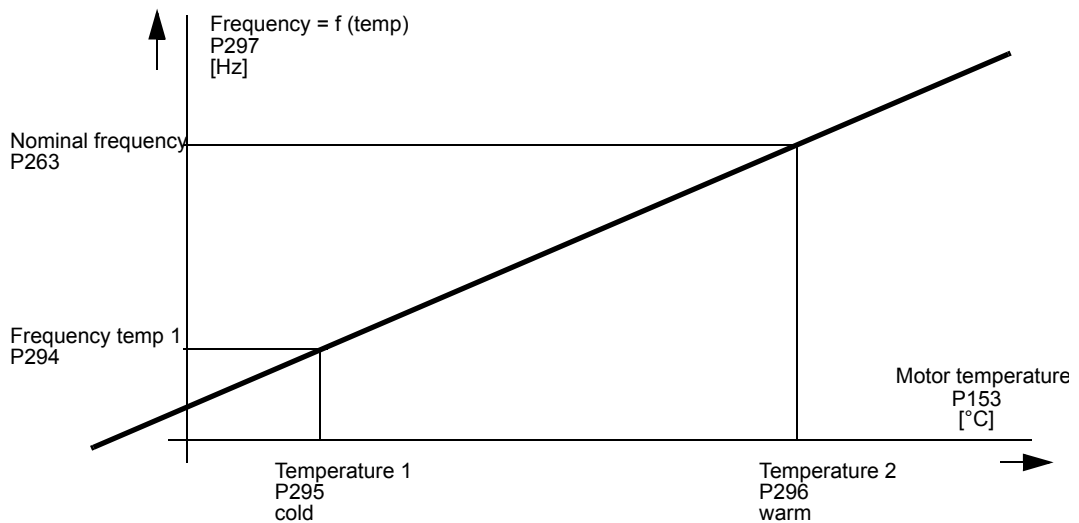

As a good approximation, you can expect for the slip while the machine – P295 MM temperature 1 – is cold, approximately 75% of the rated slip under thermic loading.

This results in the frequency that has to be set for temperature 1:

$$P294 \text{ MM frequency temp1} = \frac{P263 + \frac{P262}{60 \cdot \frac{s}{\text{min}}} \cdot P033 \cdot 0,3}{1,3}$$

Example:

P263 MM nominal frequency= 53,60 Hz
 P295 MM temperature 1 = 20 °C
 P296 MM temperature 2 = 80 °C
 P262 MM nominal speed = 1500 rpm
 P033 Mot no. of pole pairs = 2

$$P294 \text{ MM frequency temp1} = \frac{53,6 \text{ Hz} + \frac{1500\text{rpm}}{60 \cdot \frac{s}{\text{min}}} \cdot 2 \cdot 0,3}{1,3} = 52,77 \text{ Hz}$$

P291 MM MGen1 Nnominal

P292 MM MGen2 12000 rpm

This parameter sets the torque limiting at generator-operation of the asynchronous machine.

This results in identical torque in motor as well as generator terms.

It is $0 \% \leq P292 \leq P291 \leq 100 \%$

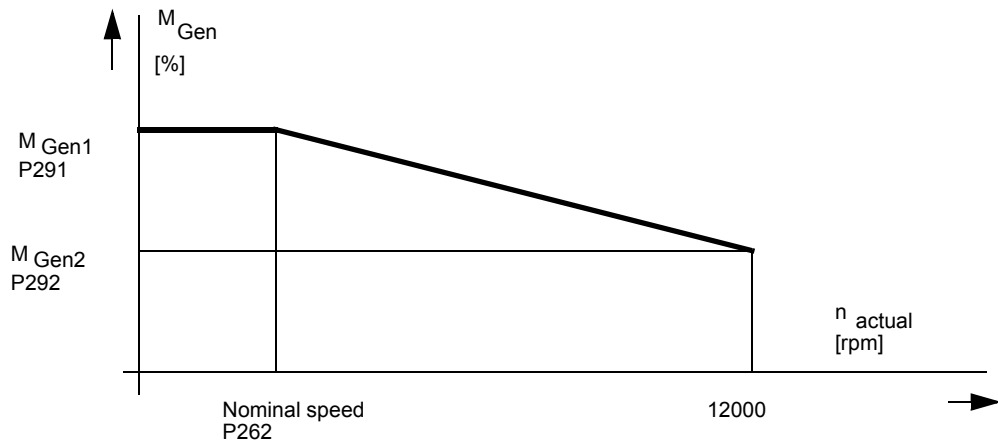

As a good approximation, you can expect around 95 % for P291 $M_{Gen1} N_{nom}$ and approximately 60 % for P292 $M_{Gen2} 12000$ rpm.

P303 MM Kp field weakening

P304 MM Tn field weakening

The motor voltage in the field weakening range is set depending on the intermediate circuit voltage in 2 operation modes:

Operation mode 1: With the set motor and intermediate circuit voltage the modulator doesn't reach the limit. The field weakening starts at n_{nom} . In the field weakening range the EMC is constant.

Operation mode 2: If the mains voltage is low, the intermediate circuit voltage available is not high enough. The field weakening starts below n_{nom} .

This parameters depend on the mechanic time constant T_m . If T_m is lower, K_p field weakening must be set higher.

Setting of the AM model and the flow controller:

- MM mode bit no. 3 = 1 (1 : AM) P269
- MM mode bit no. 2 = 1 (torque available after $3 \cdot T_R$) P269
- MM Kp field weakening = 1 ... 5 P303
- MM Tn field weakening = 5 ms P304

7.7 Motor Overload Monitoring

Function

The overload monitor protects the power unit/motor from thermal overloading. The temperature of the power unit/motor is imitated and monitored by an I²t model.

Motor model:

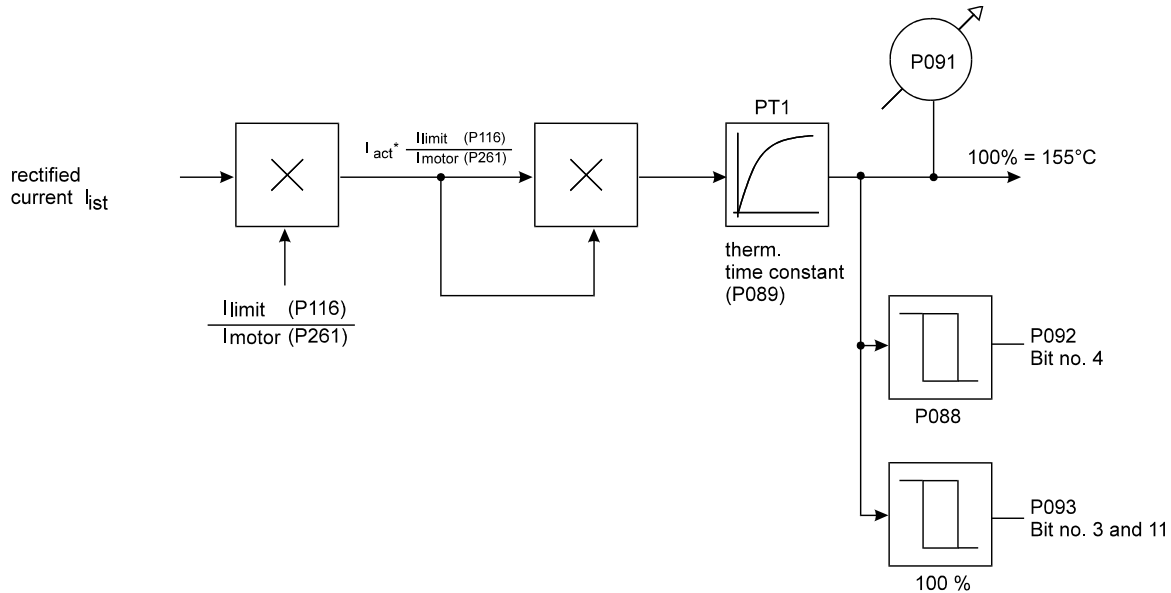

The motor temperature is measured when P089 = 0 and in state NOT READY TO START (if motor temperature sensor is available).

The PT₁ element is initialized on this motor temperature. Following calibration is valid 40°C ↔ 0 % and 155°C ↔ 100 % of P091. Therefore the error „overload monitoring“ can appear in spite of low current or in the start phase.

Parameter overview

Parameter	Name	Range min. ... max.	Unit	Display only
P093	I ² t state	0000 ... FFFF		×
P089	I ² t time constant motor	0 ... 3600	s	
P088	I ² t warning limit motor	0,00 ... 100,0	%	
P091	I ² t value motor	0,00 ... 40000,00	%	×

Example

Power unit: BUS 621

$$I_{nom} = 10 A_{eff}$$

Motor: DS 56 L - 3000; (P065)

$$I_{nom} = 5,1 A_{eff}$$

$$T_t = 10 \text{ min.} = 600 \text{ s}$$



NOTE

The motor nominal current is set in parameter MM motor nominal current (P261).

P116: Set current I_{limit} (maximum current e.g. at acceleration) e. g. $I_{limit} = 8 \text{ A}$

P088: 80 % (warning limit)

P089: 600 s

P099: Level change from 0 % to 100 % I_{nom} of power unit

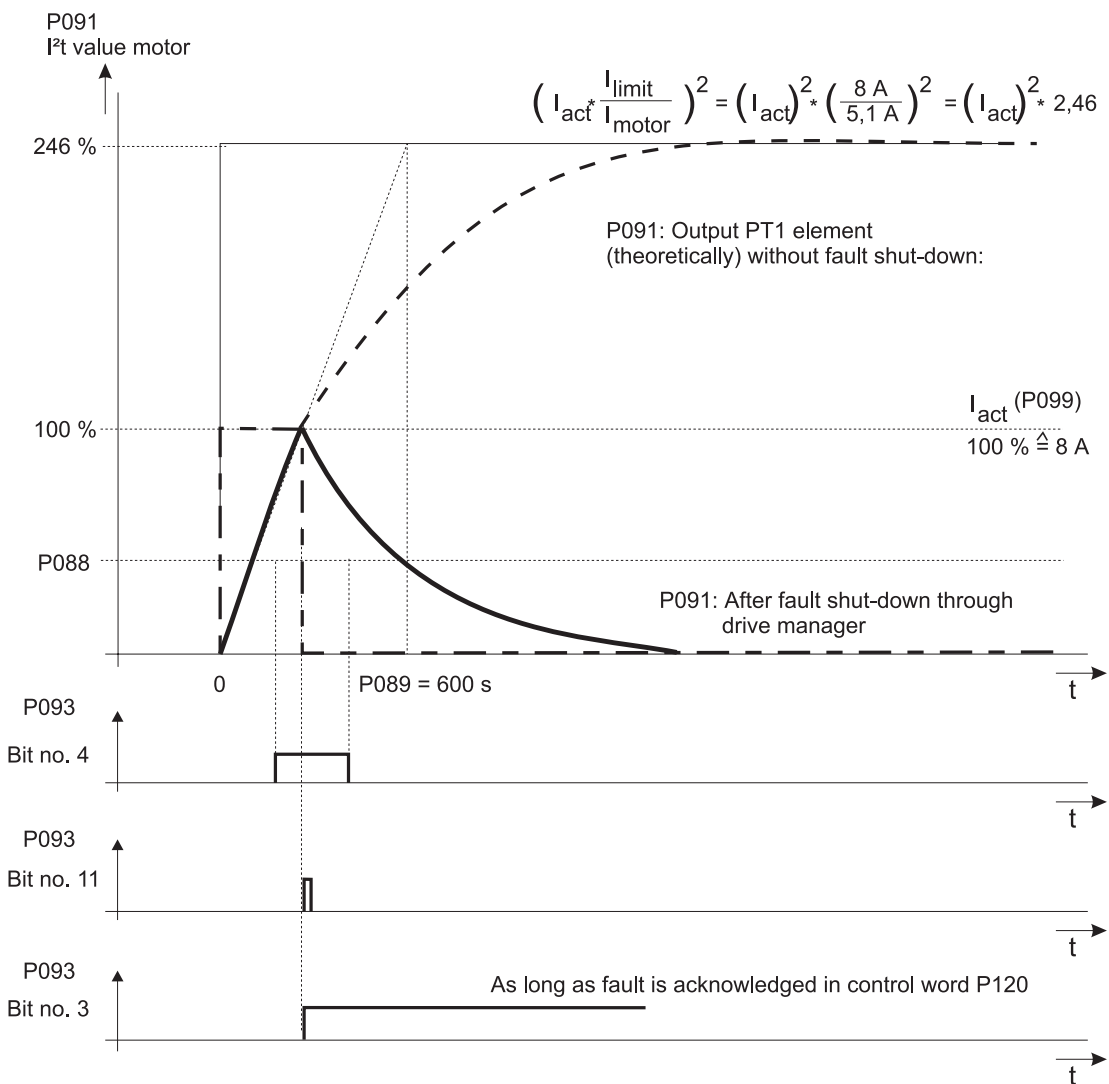

Parameters

Parameter description

P093 I2t state

The state shows the function module state.

Bit no.	Meaning
0 ... 2	000: STOP 001: RUN 010: LINE 011: STAND_BY
3	1: Error in function module, error code see M error code (P124)
4	1: Warning: I ² t value motor > limit motor (P088)
5 ... 10	reserved
11	1: I ² t value motor > 100 %
12 ... 15	reserved

P089 I2t time constant motor

The thermal time constant of the motor T_t [s] (see technical data motor) must be entered in sec..

If motor time constant = 0 the overload monitoring is turned off.

P088 I2t warning limit motor

If this value is exceeded the bit „motor overload warning“ (bit no. 4, P093) is set.

Standardization

$$100 \% \leftrightarrow 155\text{ }^{\circ}\text{C}$$

P091 I2t value motor

This parameter shows the output of the PT1 element.

Standardization

$$100 \% \leftrightarrow 155\text{ }^{\circ}\text{C}$$

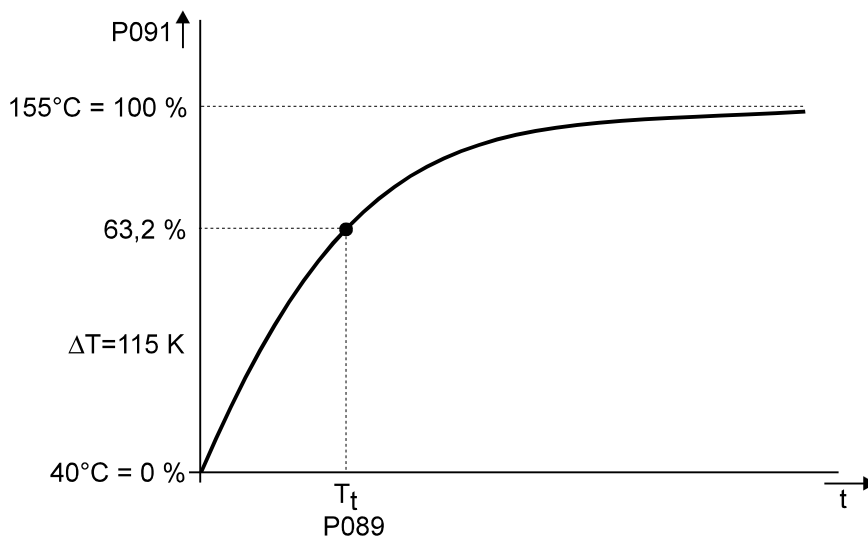

7.8 Motor Temperature Monitoring

Function

This module protects the motor from thermal overloading.

Parameter overview

Parameter	Name	Range min. ... max.	Unit	Display only
P151	MT state	0000 ... FFFF		×
P152	MT mode	0000 ... 0029		
P153	MT temperature	-80 ... 250	°C	×
P154	MT threshold 1	-80 ... 250	°C	
P155	MT threshold 2	-80 ... 250	°C	
P156	MT shutdown threshold	-80 ... 250	°C	
P157	MT hysteresis	0 ... 5	°C	

Parameter description

P151 MT state

The module state is displayed here.

Bit no.	Meaning
0 ... 2	000: STOP motor temperature monitoring is switched off 001: RUN motor temperature monitoring is active
3	1: error in function module, error code see M error code (P124)
4	1: motor temperature has exceeded threshold 1
5	1: motor temperature has exceeded threshold 2
6	1: motor temperature has exceeded shutdown threshold
7	1: shutdown switch / PTC thermistor responses
8	1: short circuit temperature sensor
9 ... 15	reserved

P152 MT mode

This parameter sets the motor temperature recording type.

Bit no.	Meaning
0 ... 2	Sensor type 000: No sensor, temperature monitoring is switched off 001: Temperature sensor KTY 84 (PTC) 010: reserved 011: reserved 100: reserved 101: reserved 110: reserved 111: reserved
3	0: If the shutdown threshold P156 is exceeded, the error bit in MT state is enabled and a shutdown follows. 1: If the shutdown threshold P156 is exceeded, the warning bit no. 6 in MT state is enabled and no shutdown follows.
4 ... 5	Input mode 00: The temperature is monitored with connector X26, pin no. 9 and 10 01: The temperature is monitored with connector X24, pin no. 14 and 15 (interface encoder 1) 10: The temperature is monitored with connector X25, pin no. 14 and 15 (interface encoder 2) 11: reserved
6	Short circuit monitoring temperature sensor 0 : If the temperature falls below the threshold value of -40°C the error bit in the MT status is set and the controller is disabled. 1 : If the temperature falls below the threshold value of -40°C only the warning bit No. 8 in the MT status is set. The controller is not disabled.
7 ... 15	reserved

P153 MT temperature

This parameter indicates the measured motor temperature if a temperature sensor is used.

P154 MT threshold 1

P155 MT threshold 2

P156 MT shutdown threshold

The temperature ascertained by the temperature sensor is compared to these parameters and the relevant bits are set in the status word.

P157 MT hysteresis

On exceeding a threshold the relevant set and it is reset only after falling below the threshold minus hysteresis.

Example:

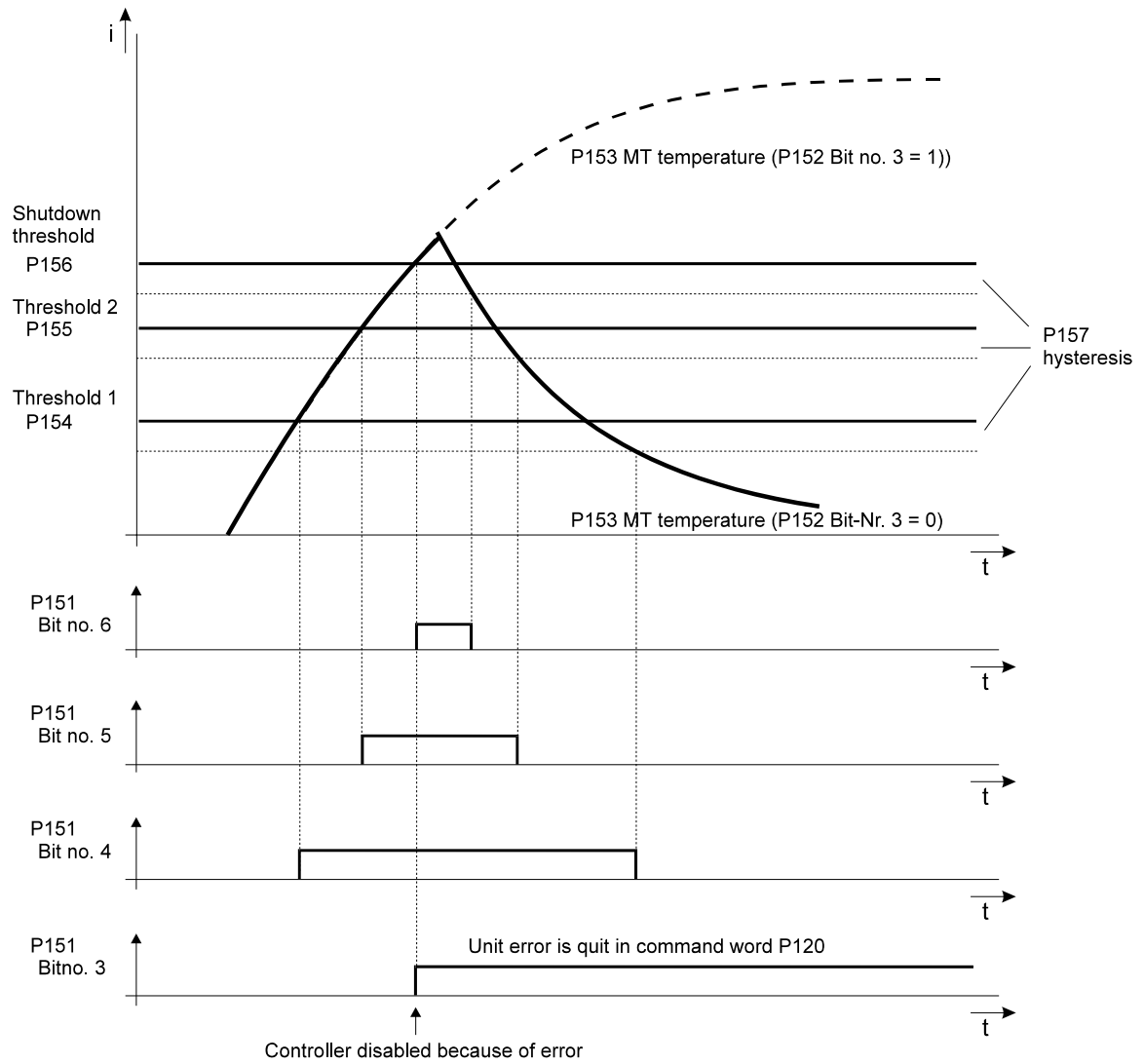

7.9 Field Angle Calculation

Function

In this function module, the electrical field angle is calculated from the number of pole pairs of the motor and the mechanical rotor angle. Apart from this, the module contains the algorithms for determining the locating position and the rotor position, which play a significant part in the operation of synchronous machines.

Parameter overview

Parameter	Name	Range min. ... max.	Unit	Display only
P036	Mot state	0000 ... FFFF		×
P031	Mot mode	0 ... 4		
P033	Mot no. of pole pairs	1 ... 120		
P034	Mot rotating field	0 ... 1		
P037	Mot delta l	1 ... 50		
P039	Mot delta Rho	1 ... 50		
P035	Mot locating angle	0.0 ... 360,0	degrees	
P030	Mot phi mechanical	0.0 ... 360,0	degrees	×
P032	Mot rho electrical	0.0 ... 360,0	degrees	×

Parameter description

P036 Mot state

This parameter shows the status of the function module.

Bit No.	Meaning
0 ... 2	0: STOP 1: RUN Normal operation 3: STAND_BY Optimization algorithms are running
3	1: Error in module; for error code, refer to M error code (P124)
4	1: Locating point found (method 0,1) 0: Locating point still unknown
5	1: Rotor position found (method 2, 3, 4) 0: Rotor position still unknown
6 ... 15	reserved



Note

Before the controller can be enabled, following parameters must be set:

- Motor model
 - Limit current
 - Encoder
 - Current controller
 - Operation mode
- Hardware enables

P031 Mot mode

Selection of the optimization method for Location Point Reference Setting mode.

With all the optimization methods, the controller sets its own current specified value using parameter P067 M specified value. This means that the system must not write to this parameter during optimization (e.g. via the communications interfaces, digital inputs, etc.).

Value	Meaning
0	Set reference to encoder's installation position (location point) (method 0)
1	Set reference to encoder's installation position (location point) (method 1)
2	Set reference to rotor position of synchronous machine (method 2)
3	Start up a clockwise-rotating synchronous machine (method 3)
4	Start up a counterclockwise-rotating synchronous machine (method 4)

To 0: Mode Set reference to encoder's installation position (location point) is intended for operation of a synchronous machine with an absolute value encoder. You **must** dismount the motor when carrying out this optimization. The current specified value increases in a linear way from 0% to 100%; after this, the system determines the current values and sets bit no. 4, Locating position found, in Mot state.

To 1: Mode Set reference to encoder's installation position (location point) is intended for operation of a synchronous machine with an absolute value encoder. You **must not necessarily** dismount the motor when carrying out this optimization. However, the motor shaft must be able to move load-free in both directions by about one or two degrees. After completing optimization, the system sets bit no. 4, Locating position found, in Mot state.

To 2: Mode Set reference to rotor position is intended for operation of a synchronous machine with an incremental encoder. This means that before commissioning a drive of this type, you must carry out this optimization function first. You **must not necessarily** dismount the motor when carrying out this optimization. However, the motor shaft must be able to move load-free in both directions by about one or two degrees. After completing optimization, the system sets bit no. 5, Rotor found, in Mot state.

To 3 and 4: These modes are intended for operation of a synchronous machine with an incremental encoder. The system keeps moving the synchronous machine with a clockwise- or counterclockwise-rotating electrical angle until the incremental encoder's zero pulse has been measured. After this, the system sets bit no. 5, Rotor found, in Mot state.

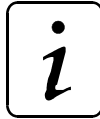

Note

These both methods are only necessary to find the zero pulse of the incremental encoder. After that the incremental encoder acts as an absolute value encoder. In order to run a synchronous machine safely the locating angle must be at least one time searched and stored.

P033 Mot no. of pole pairs

Pole pairs of the used motor.

P034 Mot rotating field

This parameter matches the control to the rotating field of the motor.

Value	Meaning
0	motor with anti-clockwise rotating field (phase V and W changed)
1	motor with clockwise rotating field

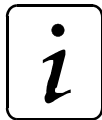

Note

After making changes to Mot rotating field, you **must** save data set 0 (the boot data set) and reboot the controller!

P037 Mot delta I

Using this parameter, you can specify the setting for the current rise per unit of time $\frac{di}{dt}$. This is only necessary for Mot Modes 1 and 2. The value 1 means that the current rise per second is 3,05 % of the limit current (P166 LT I lim).

P039 Mot delta rho

This parameter sets the angular velocity of the electrical angle $\frac{dRho}{dt}$. This is only necessary for Mot Modes 1 and 2. The value 1 means that the angular change per second is 2,75° electrical.

P035 Mot locating angle

This parameter shows the locating angle that was determined in mode Set reference to locating point.

P030 Mot phi mechanical

This parameter displays the mechanical rotor angle.

P032 Mot rho electrical

This parameter displays the calculated electrical field angle.

7.10 Encoder Manager

Function:

The module manages the classification of encoder 1 (X24) and 2 (X25) to motor control, speed controller and synchronisation control as well as incremental encoder emulation.

Parameter overview

Parameter	Name	Range min. ... max.	Unit	Display only
P225	EM state	0000 ... FFFF		×
P228	EM encoder types	000000FF		×
P226	EM mode	0000 ... 003F		
P227	EM no. of graduation marks	128 ... 32767	Ink	
P229	EM offset zero impulse	0000 ... FFFF	Inc	
P019	EM maximum speed	500 ... 12000 from SW 14.07 500 ... 24000	rpm	
P224	EM Kp	0 ... 255.9		

Parameter description

P225 EM state

Display of the internal module state

Bit no.	Meaning
0 ... 2	000: STOP 001: RUN 101: INIT Initialization, wait for the initialization of the encoder modules.
3	1: Error in function module, error code see M error code (P124)
4 ... 6	reserved
7	Absolute position of the encoder for motor control is not known
8, 9	reserved
10	N=0 - message from the encoder selected for the motor management (via GM mode bit 0)
11 ... 15	reserved



NOTE

The initialization of the incremental encoder emulation can only be done after the encoder, to which it is connected, is initialized.

If an absolute value encoder is used, the ICE emulation takes place immediately

If this encoder is an incremental encoder the initialization will be delayed (bit 7 Parameter P 226), until the zero pulse of the encoder is found. During this time P225 EM state is INIT.

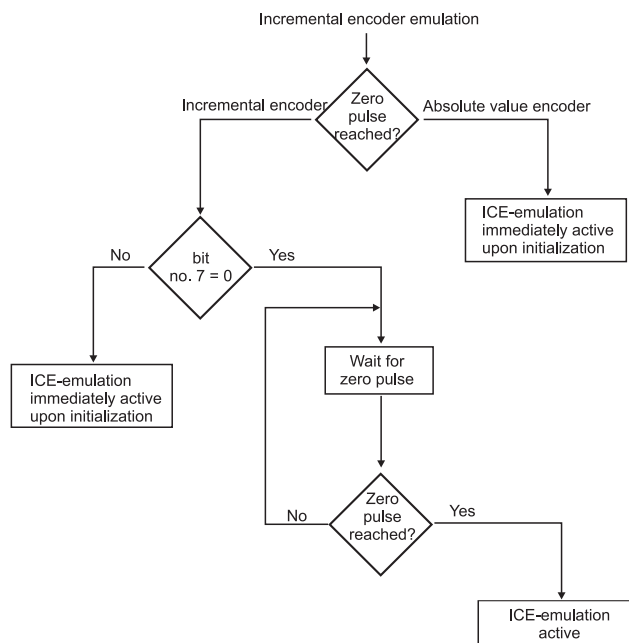

P228 EM encoder types

Shows the really quipped encoder modules (see type code).

Bit no.	Meaning
0 ... 3	Encoder type at connection 2 (X25) 0: no encoder A: resolver B: sinus incremental encoder 5 V C: absolute value encoder with asynchronous serial interface 8 V D: absolute value encoder with synchronous serial interface 5 V (from SW 14.08) E: rectangle incremental encoder 5 V
4 ... 7	Encoder type at connection 2 (X24) 0: no encoder A: resolver B: sinus incremental encoder 5 V C: absolute value encoder with asynchronous serial interface 8 V D: absolute value encoder with synchronous serial interface 5 V (from SW 14.08) E: rectangle incremental encoder 5 V
8 ... 15	reserved

P226 EM mode

Bit no.	Meaning
0	0: Rotor angle and speed is measured by encoder 1 1: Rotor angle and speed is measured by encoder 2 This bit can only be changed if the position controller's state is STOP.
1	0: Incremental encoder emulation is connected with position actual value G1/G2. 1: Incremental encoder emulation is connected with position set value.
2	0: Incremental encoder emulation is switched off 1: Incremental encoder emulation is active
3	0: Incremental encoder emulation is connected with encoder 1 1: Incremental encoder emulation is connected with encoder 2
4	Change polarity of incremental encoder emulation: 0: With a clockwise-rotating encoder (depending on bit number 3) the system outputs a clockwise-rotating signal pattern on connector X 27. 1: With a clockwise-rotating encoder (depending on bit number 3) the system outputs a counterclockwise-rotating signal pattern on connector X 27.
5	0: The no. of graduation marks is multiplied by 1 1: The no. of graduation marks is multiplied by 8
6	up to version 3.03 0: Smoothing of incremental encoder emulation is inactive 1: Smoothing of incremental encoder emulation is active from version 3.03: reserved
7	up to version 3.08: reserved from version 3.08: 0: activation of incremental encoder emulation after init of encoder 1: instant activation of incremental encoder emulation (if bit 2 = 1)
8 ... 15	reserved

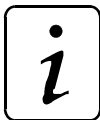

NOTE

After setting the mode parameter the data set 0 (boot data set) should be saved and the controller should be booted new.

The incremental encoder emulation can be used in combination with following encoders (see type code, too):

Incremental encoder emulation	Encoder 1 X24	Encoder 2 X25
not active bit no. 2 = 0	Abs. encoder ASI 8 V Abs. encoder SSI 5 V rectangle inc. 5 V sine inc. 5 V resolver	Abs. encoder ASI 8 V Abs. encoder SSI 5 V rectangle inc. 5 V sine inc. 5 V resolver
active bit no. 2 = 1	resolver 2 pole pairs or no encoder	Abs. encoder ASI 8 V Abs. encoder SSI 5 V rectangle inc. 5 V sine inc. 5 V resolver

The internal delay time between getting the encoder signals (encoder 1 (X24) and encoder 2 (X25) and the output through the incremental encoder emulation X27 is maximal 90 µs.
The minimum output impulse length can be calculated the following way:

$$t_{\min} \geq \frac{6562500 \cdot 4}{n_{\max} \cdot \text{pulsenumber}} [\mu\text{s}]$$

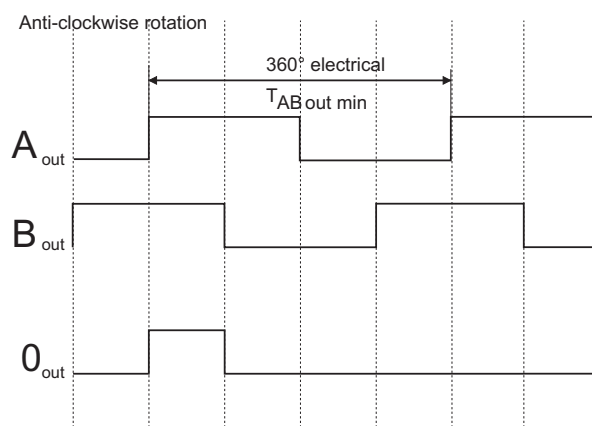
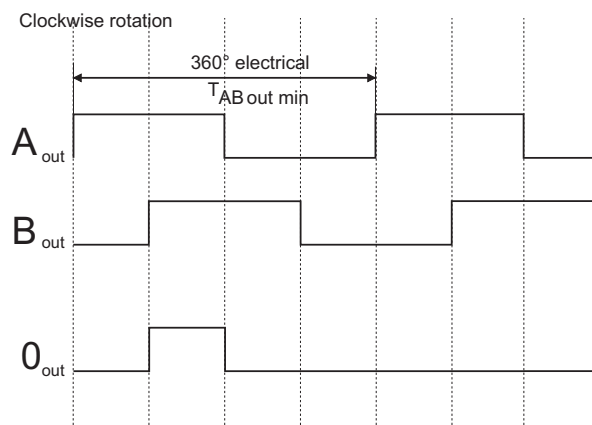

$$T_{\text{ABout min}} = (2 \cdot t_{\min})[\text{s}]$$

$$f_{\text{ABout max}} = \frac{1}{T_{\text{ABout min}}} \left[\frac{1}{\text{s}} \right]$$

P227 EM no. of graduation marks

This parameter sets the no. of graduation marks of the incremental encoder emulation. The no. of graduation marks refers to 1 revolution of encoder chosen with P226 EM mode bit no. 3. Bit no. 5 of EM mode selects the multiplicands for the number of graduation marks. The limit frequency is 1,6 MHz.



NOTE

If the incremental encoder emulation is evaluated using an external unit, e.g. an NC-control, it must be ensured that the counter input of the unit is able to process a frequency of

$$f_{\text{ABout max}} = \frac{n_{\text{max}} \cdot \text{no. of graduation marks}}{8 \cdot 6562500} \cdot 10^6$$

P229 EM offset zero impulse

This parameter sets the angle offset between the zero angle of encoder chosen with P226 and zero impulse of incremental encoder emulation.

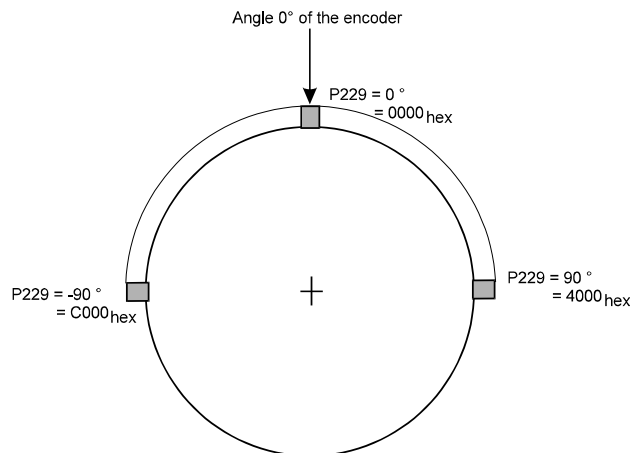

PO19 EM maximum speed

This parameter sets the maximum speed. This speed corresponds to 100 % in all other speed specifications e.g. speed set values, speed actual values and monitoring thresholds of both encoders.

e.g.: 100 % $n_{\text{set}} \leftrightarrow 2800 \text{ rpm}$, if maximum speed is set to 2800 rpm.

P224 EM Kp

This parameter sets the P gain of the feedback loop for the incremental encoder emulation. The P gain k_p must be checked. If the P gain is set too high the incremental encoder emulation oscillates.

$$k_p \leq 0,8 \cdot \text{INT}\left(\frac{131,25 \cdot 10^6}{n_{\max} \cdot \text{Strichzahl}}\right) \cdot \frac{2^{16}}{20\text{MHz}} \cdot \frac{1}{2 \cdot f_s}$$

$f_s = 4$ or 8 kHz

INT: only the integer is used for further calculation.

7.11 Touch probe cycle

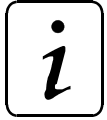

NOTE

This hard- and software is required for the touch probe cycle:

Software

softwareversion **3.08 or higher**

Encoder type

not resolver

Function

The function Touch Probe Cycle is an extension of the module Encoder Manager. By using the Touch Probe Cycle it is possible to save the current value of position into the V-controller at a definite point of time. The input for the Touch Probe Cycle is by the digital input 1 (Pin 15 at X26). Additional programming of the digital input 1 into a target parameter is allowed.

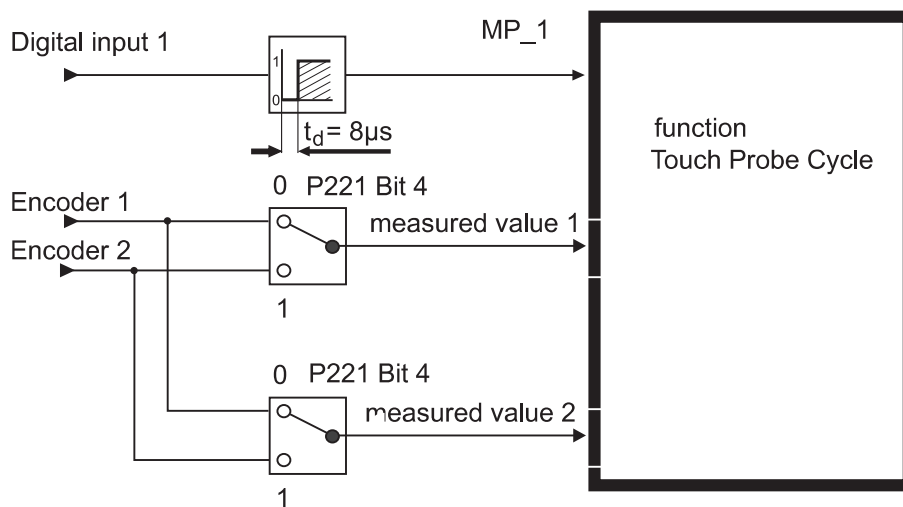

Store measured value via zero pulse

The storage of the measured value via zero pulse extends the function touch probe cycle. Here the actual position value is stored via the zero pulse of the encoder in spite of the signal of the touch probe input.

The storage of the measured value via zero pulse is activated with P221 GM measured value command bit no. 0 = 1. In addition only for this measured value storage a qualification signal can be programmed. The storage is triggered by the touch probe input MP_1 (pin no. 15 at X26) and the level is set in the measured command bit no. 11. Via the connection with the touch probe input the activation time can be reduced to the hardware time delay. The stored value is then independent of internal controller program run times.

The selected encoder (bit no. 4 GM measure value command) defines the stored position and with its zero pulse the measured value storage itself.

Run of a measured value storage via zero pulse with MP1 as qualification signal..

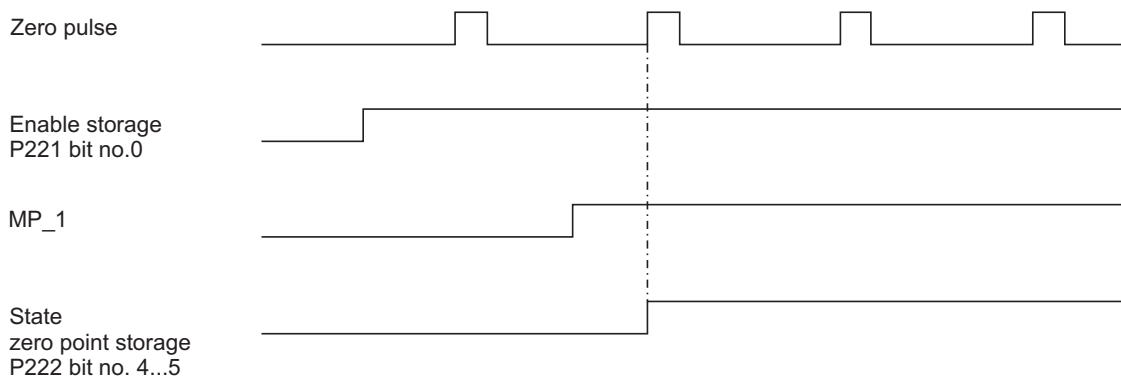

Parameter overview

Parameter	Name	Range min. ... max.	Unit	Display only
P221	EM measuring-command	0000 0F31		
P222	EM measuring-state	0000 ... FFFF		X
P223	EM measured val phi1	00000000 ... FFFFFFFF		
P233	EM measured val rev1	00000000 ... FFFFFFFF		
P234	EM measured val phi2	00000000 ... FFFFFFFF		
P235	EM measured val rev2	00000000 ... FFFFFFFF		

Parameter description

P221 EM measuring-command

Command word for the Touch Probe Cycle.

Bit no.	Meaning
0	0: Storage of measured value disabled 1: Storage of measured value enabled
1 ... 3	reserved
4	Measured value - storage of current value of position disabled 0: Encoder 1 1: Encoder 2
5 ... 8	Measured value - storage 0000: once at positive slope (into measured value 1) 0001: once at positive slope (into measured value 2) 0010: once at negative slope (into measured value 1) 0011: once at negative slope (into measured value 2) 0100: continuous at positive slope (into measured value 1) 0101: continuous at positive slope (into measured value 2) 0110: continuous at negative slope (into measured value 1) 0111: continuous at negative slope (into measured value 2) 1000: twice; first value at positive slope (into measured value 1) second value at negative slope (into measured value 2) 1001: twice; first value at negative slope (into measured value 1) second value at positive slope (into measured value 2) other: reserved
9	0: Measured value storage via touch probe input 1: Measured value storage via zero pulse
10	0: Qualification switched off 1: Qualification switched on (only when storing via zero pulse)
11	0: Qualification is triggered via signal level = 1 1: Qualification is triggered via signal level = 0
12 ... 15	reserved

Bit 0 is used for turning the Touch Probe Cycle on and off.

If "storage once" is enabled (see Bit 5 – 8) and values are already stored, then Bit 0 must be reset and set again to reactivate the Touch Probe Cycle.

In mode "storage twice" the same as mentioned above applies. One thing is essential for both modes:

first and second slope must have an offset of at least 1ms !

In mode "continuous" values are stored each time a positive or negative slope appears, but only when the value has changed. This also applies for switching from mode "once" or "twice" to mode "continuous".

Changes in Command-Bits 5 – 8 are only taken over by the controller when bit 0 indicates a positive slope (0 → 1).

P222 EM measuring-state

This parameter indicates the state of the storage of measured values.

Bit-Nr.	Bedeutung
0	0: storage of measured values disabled 1: storage of measured values enabled
1 ... 3	Reserve
4 ... 5	State of storage of measured values 1 00: disabled 01: storage not yet done 10: storage done 11: mode „continuous“ storage
6 ... 7	State of storage of measured values 2 00: disabled 01: storage not yet done 10: storage done 11: mode „continuous“ storage
8	State of input Touch Probe * 0: not actuated 1: actuated
9 ... 15	reserved

* display of state of input Touch Probe is activated after first enabling of storage of measured value. Before first enabling and after initialization of encoder this bit is set (this does not depend on the input level of touch probe inputs).

P223 EM measured value phi 1

This parameter is part of the stored current value of position. The drive stores the angle of the current value of position inside this parameter.

At the moment only the parameters High-Word is calculated. The Low-Word remains at 0000.

P234 EM measured value phi 2

This parameter is part of the stored current value of position. The drive stores the angle of the current value of position inside this parameter.

At the moment only the parameters High-Word is calculated. The Low-Word remains at 0000.

P233 EM measured val rev 1

see following explanation for P 235 EM measured val Rev 2.

P235 EM measured val rev 2

This parameter is part of the stored current value of position. The drive stores the number of revolutions of the current value of position inside this parameter.

The complete stored current value of position has 64 Bit.

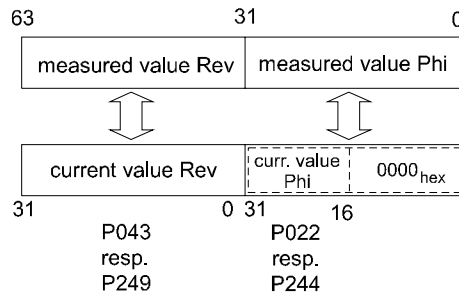

Example:

The current value of position of Encoder 2 is to be stored, first at positive then at negative slope at input of touch probe.

that is Bit 0 = 1 (storage of measured value enabled)

Bit 4 = 1 (input of encoder 2)

Bit 5 – 8 = 1000_{bin} (storage "twice" first at positive then at negative slope)

programming: P221 EM measuring command = 0111_{hex}

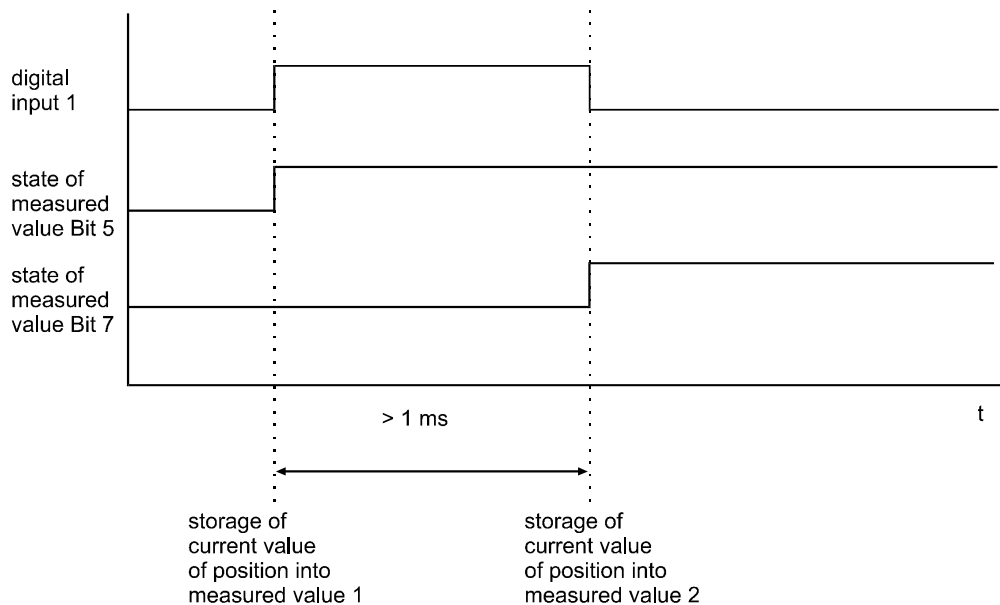

7.12 Incremental Encoder Emulation

Way of operation

The incremental encoder emulation is a part of the V-controller. Data from the V-controller connector X24/25 are processed in the V-controller and the pulse sequences A and B are generated. The zero pulse is then derived from A and B.

Protection against interference

The cables from the V-controller to the master control must be twisted pair cables.

TTL square-wave pulse sequences

Two TTL square-wave pulse sequences A and B, which are by 90° out of phase, and their inverted pulse sequences \bar{A} and \bar{B} as well as a zero pulse 0 with the inverted signal $\bar{0}$ are available as output signals.

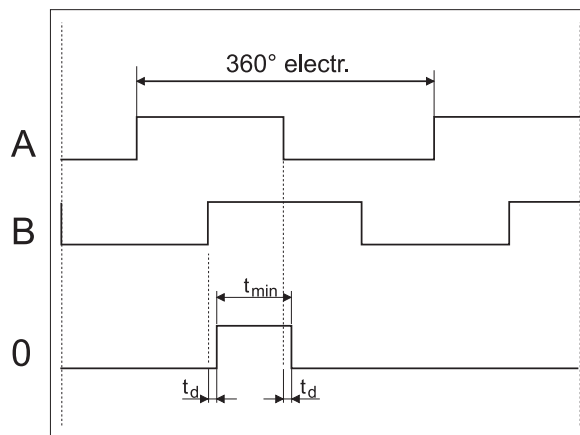

Technical Data

Connection voltage	5V ± 5% (maximum 100 mA) without load
Signal level: Output high voltage at $I_{OH} = -20\text{mA}$	2,5 V_{min}
Signal level: Output low voltage at $I_{OL} = -20\text{mA}$	0,5 V_{max}
Input frequency control	max. 1,6 MHz ¹⁾
Switching time: Rise time	< 50 ns
Switching time: Release time	< 50 ns
Delay time	$ t_d \leq 50\text{ns}$
Power input	0,525 W

1) You will find more information in the descriptions of the parameters P226, P227 and P019.

7.13 Evaluation Encoder 1 and Encoder 2

Parameter overview encoder 1

Parameter	Name	Range min. ... max.	Unit	Display only
P025	E1 state	0000 ... FFFF		×
P040	E1 mode	to SW 14.08 0000 ... 013F from SW 14.08 0000 ... 023F		
P024	E1 no. of graduation marks	1 ... 32767	Inc	
P026	E1 revolutions	1 ... 4096		
P062	E1 N smoothing actual value	0,0 ... 50,0	ms	
P023	E1 N actual value	-199,99 ... +199,99	%	×
P043	E1 rev actual value	00000000 ... FFFFFFFF		×
P022	E1 phi actual value	00000000 ... FFFFFFFF		×
P020	E1 shift factor	0 ... 16	bit	
P021	E1 position actual value	0000 ... FFFF		
P041	E1 delta Phi 16	8001 ... 7FFF		×
P042	E1 delta Phi 32	80000001 ... 7FFFFFFF		×
P044	E1 sine measured value	-1,0000 ... +1,0000		×
P045	E1 cosine measured value	-1,0000 ... +1,0000		×
P026	E1 revolutions	1 ... 4096		
P107	E1 N=0 threshold	0,01 ... 25,00	%	
P108	E1 N>Nx ON threshold	0,00 ... 150,00	%	
P109	E1 N>Nx OFF threshold	0,00 ... 150,00	%	
P046	E1 over speed	0,00 ... 199,99	%	

Parameter overview encoder 2

Parameter	Name	Range min. ... max.	Unit	Display only
P240	E2 state	0000 ... FFFF		×
P241	E2 mode	to SW 14.08 0000 ... 013F from SW 14.08 0000 ... 023F		
P242	E2 no. of graduation marks	1 ... 32767	Inc	
P232	E2 revolutions	1 ... 4096		
P238	E2 N smoothing actual value	0.0 ... 50,0	ms	
P243	E2 N actual value	-199,99 ... +199,99	%	×
P249	E2 rev actual value	00000000 ... FFFFFFFF		×
P244	E2 phi actual value	00000000 ... FFFFFFFF		×
P236	E2 shift factor	0 ... 16		
P237	E2 position actual value	0000 ... FFFF		
P247	E2 delta Phi 16	8001 ... 7FFF		×
P248	E2 delta Phi 32	80000001 ... 7FFFFFFF		×
P230	E2 sine measured value	-1,0000 ... +1,000		×
P231	E2 cosine measured value	-1,0000 ... +1,000		×
P232	E2 revolutions	1 ... 4096		
P104	E2 N=0 threshold	0,01 ... 25,00	%	
P105	E2 N>Nx ON threshold	0,00 ... 150,00	%	
P106	E2 N>Nx OFF threshold	0,00 ... 150,00	%	
P239	E2 over speed	0,00 ... 199,99	%	

Parameters

Parameter description

P025 E1 **state**

P240 E2 **state**

This parameter indicates the encoder evaluation status

Bit no.	Meaning
0 ... 2	000: STOP 001: RUN 101: INIT Initialization of the position actual value perhaps waiting for the zero pulse of an incremental encoder
3	1: Error in function module, error code see M error code (P124)
4	logic level or zero trace
5	toggle bit for zero trace: changes at every zero impulse *
6	1: $ N \text{ actual value} > \text{overspeed threshold (P046 or P239)}$ If this encoder controls the motor, the exceeding leads to a error message and disables the controller.
7	1: Absolute position of encoder is not known.
8 ... 9	reserved
10	0: $ N \text{ actual value} \neq 0$ 1: $ N \text{ actual value} = 0$ (below $N = 0$ threshold)
11	0 → 1: $ N \text{ actual value} > N_x \text{ ON (P108, P105)}$ 1 → 0: $ N \text{ actual value} > N_x \text{ OFF (P109, P106)}$
12	reserved
13	1: limit value reached; $ N \text{ actual value} > \text{maximum speed P019}$
14	to SW 14.07 reserved from SW 14.07 ¹⁾ 0: result of $\sin^2\cos^2$ monitoring okay 1: result of $\sin^2\cos^2$ monitoring exceeded permitted limits
15	to SW 14.07 reserved from SW 14.07 ²⁾ 0: field angle within limit 1: field angle error larger than limit of $\pm 45^\circ$

* with active synchronization of the OS to an external signal (P167 $\neq 0$), the display of the toggle bit at the G2 is invalid.

1) The bit is updated independent on the activation of $\sin^2\cos^2$ monitoring.

The bit is set for at least 8 ms.

2) The bit is updated independent on the activation of field angle monitoring.



NOTE

The bit no. 4 and 5 are specially destined for the adjustment of encoders. Incremental encoders with high no. of graduation marks can be fast adjusted, if this bits are connected with the free programmable LEDs.

P040 E1 mode

P241 E2 mode

This parameter sets the encoder evaluation.



NOTE

After setting the mode parameter the data set 0 (boot data set) should be saved and the controller should be new booted.

Bit no.	Meaning
0	Encoder polarity: 0: No sign reversal, turning clockwise encoder supplies positive speed actual value. 1: Sign reversal, turning clockwise encoder supplies negative speed actual value.
1	Polarity position counting: 0: Positive speed actual value effects positive position change 1: Positive speed actual value effects negative position change .
2	0: The multiplier for no. of graduation marks is 1. 1: The multiplier for no. of graduation marks is 8.
3	Initialization of the position actual values with incremental encoders 0: Initialization of position actual values without reference to the zero pulse of the encoder 1: Initialization of position actual values with reference to the zero pulse of the encoder
4 ... 7	Encoder type: 0000: no encoder 0001: resolver 0010: rectangle encoder 0011: sine encoder
8 ... 11	Communication protocol: 0000: no protocol 0001: Hiperface-Protocol for SinCos encoder from Fa. Stegmann ((SCM70, SCS70, SCM50/60, SCS50/60, SKS36 or SKM36)) 0002: EnDat-Protocol for encoder from Fa. Heidenhain (ab SW 14.08)
12	to SW 14.07 reserved from SW 14.07 sin²cos² monitoring 0: no monitoring 1: monitoring on
13	to SW 14.07 reserved from SW 14.07 Field angle monitoring 0: no monitoring 1: monitoring on
14 ... 15	reserved

Permitted setting for encoder mode, no. of graduation marks and revolutions:

Letter for encoder in type code	Mode	No. of graduation marks	Revolutions	Comment
0	0000 _{hex}	×	×	no encoder evaluation
A	0010 _{hex}	16384	1	resolver
B	0030 _{hex}	number of sine periods	1	incremental encoder sine with 5 V supply
C	0130 _{hex}	512	1 (SCS 70) 4096 (SCM 70)	sine absolute value encoder with asynchronous serial interface and 8 V supply, Hiperface-Protocol: SCS 70, SCM 70, SRS 50 and SRM 50 (software 3.09 or higher req.) by Stegmann
		1024	1 (SRS 50) 4096 (SRM 50)	
D	0230 _{hex}	encoder no. of graduation marks	encoder no. of revolutions	sine absolute value encoder with synchronous serial interface and 5 V supply, EnDat-Protocol e.g. EQN1325 by Heidenhain (from SW 14.08).
E	0020 _{hex}	no. of graduation marks	1	rectangle incremental encoder with 5 V supply

- the controller will read these values automatically via serial connection from the encoder, when SW-Version 3.05 or higher is used.

P024 E1 no. of graduation marks

P242 E2 no. of graduation marks

No. of graduation marks or number of periods of connected encoder.



NOTE

The no. of graduation marks of 2 pole resolvers must be set to 16384.

The multiplier for the no. of graduation marks is set by bit no. 5 in E1/E2 mode. The no. of graduation marks and the maximum really speed must not be greater than 1,6 MHz.

$$f = \frac{\text{No. of graduation marks} * \text{Multiplier} * \text{Speed}}{60} < 1,6\text{MHz}$$

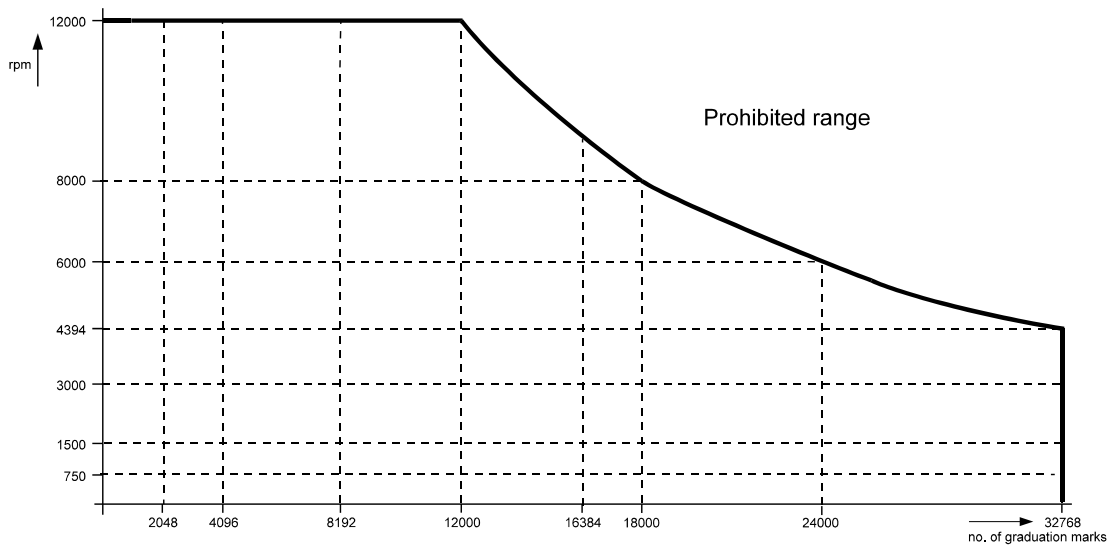

P026 E1 revolutions

P232 E2 revolutions

Number of whole revolutions that can be displayed by the encoder.

the controller will read these values automatically, when SW-Version 3.05 or higher is used

The permitted inputs are displayed in the table at E1/E2 mode.

P062 E1 N smoothing actual value

P238 E2 N smoothing actual value

This parameter sets the time constant to smooth the speed actual value for a digital PT1 element.

P023 E1 N actual value

P243 E2 N actual value

N actual value at encoder 1 or encoder 2, referring to maximum speed (P019).

100 % correspond with set maximum speed in P019.

P043 E1 Rev actual value

P249 E2 Rev actual value

Part of the position actual value: number of whole revolutions.

P022 E1 **phi actual value**

P244 E2 **phi actual value**

Part of the position actual value: the angle within one rotation, left-justified with encoder-dependent resolution.

The entire position actual value is 64-bits-long and consists of the following:

63		32	31		0
31	Rev actual value	0	31	Phi actual value	0

The system zeroes the entire position actual value after you switch on the power to the electronics. If an absolute value encoder is connected, the system reads it out and enters the information in accordance with the format shown above. The position actual value can be overwritten at any time.



NOTE

Every error that occurs in the encoder module (error code 08xx/0Axx) results in the absolute position of the encoder evaluation being lost. This means that if you use this encoder to acquire the rotor position of a synchronous machine, this position information is also lost and it is no longer possible to safely control the motor. Every time an encoder error occurs, you must therefore reinitialize the controller electronics (by turning the power off and on again).

P020 E1 shift factor

P236 E2 shift factor

P021 E1 position actual value 16

P237 E2 position actual value 16

16 bit position actual value with freely adjustable ranges for whole revolutions and angles.

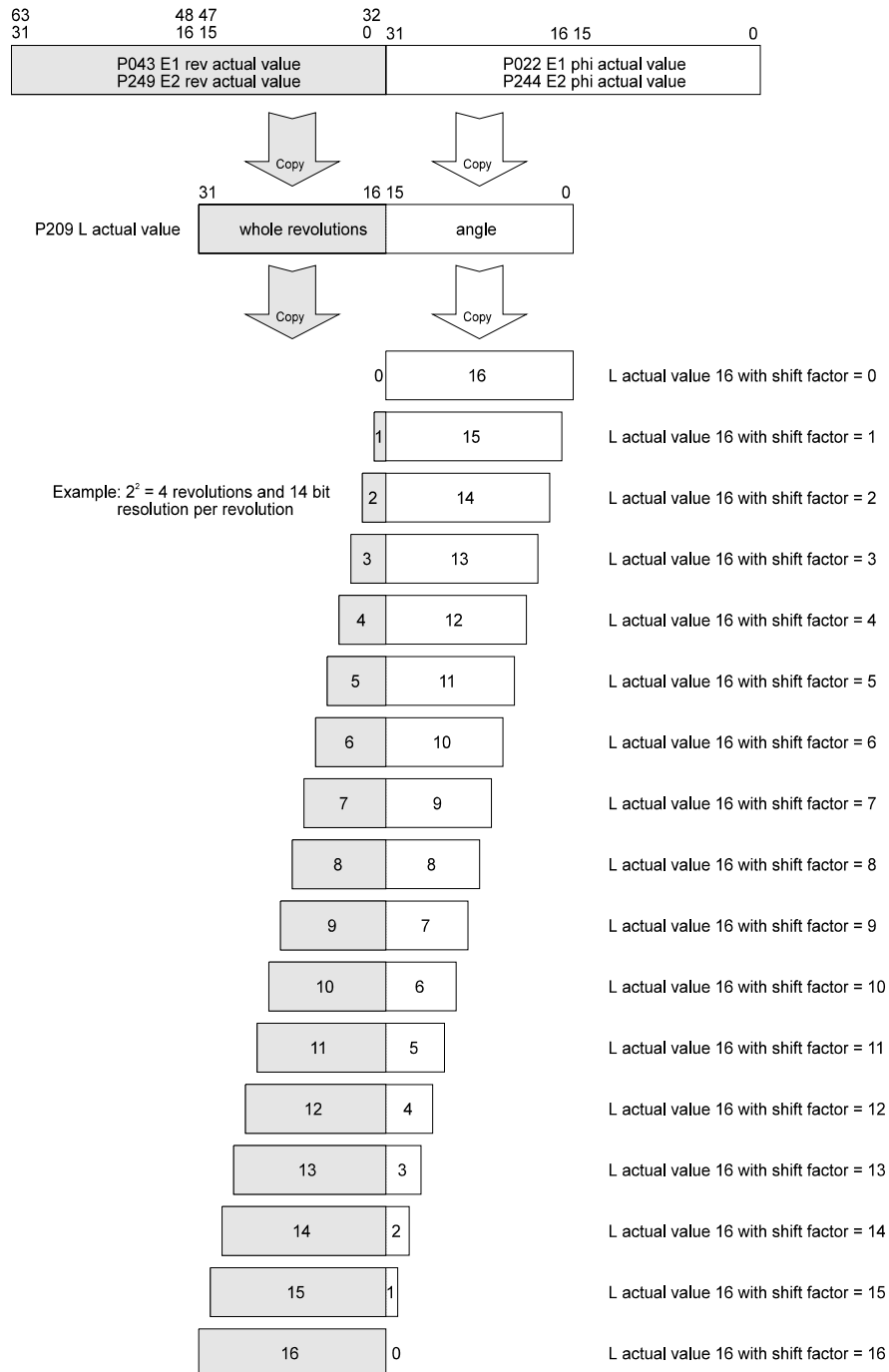

Parameters

P041 E1 **delta phi 16**

P247 E2 **delta phi 16**

P042 E1 **delta phi 32**

P248 E2 **delta phi 32**

When writing this parameter the system adds once the specified angular differences with 16- or 32-bit resolution onto the position actual value (relative angular change).

At most one set value can be operated per millisecond.

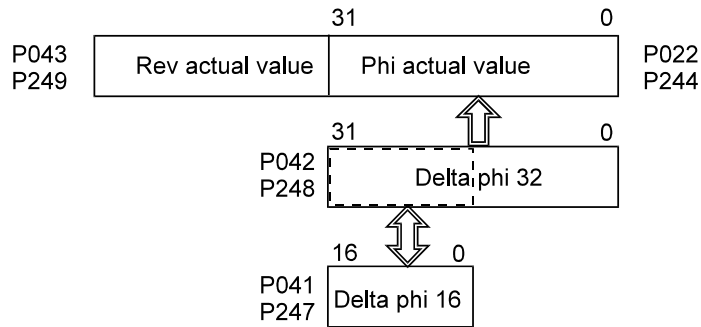

Positive and negative carries to whole revolutions (Rev actual value) are taken into account.

$$8001_{\text{hex}} = -180^\circ$$

$$0000_{\text{hex}} = 0^\circ$$

$$7FFF_{\text{hex}} = +180^\circ$$

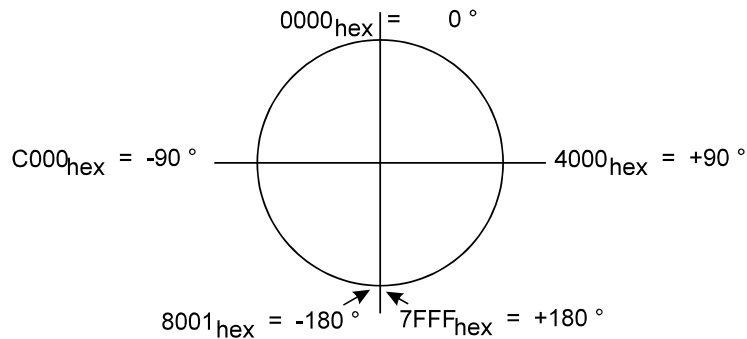

P044 E1 **sine measured value**

P045 E1 **cosine measured value**

P230 E2 **sine measured value**

P231 E2 **cosine measured value**

Measured values of connected encoder.

P107 E1 **N=0** threshold

P104 E2 **N=0** threshold

Bit no. 10 in function module state is enabled, if the absolute value of N actual value is below the threshold N=0 (P107 encoder 1 or P104 encoder 2).

The input value is related to P019 maximum speed.

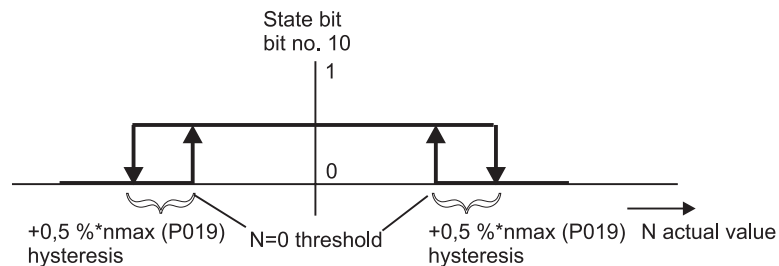

P108 E1 **N>Nx ON** threshold

P109 E1 **N>Nx OFF** threshold

P105 E2 **N>Nx ON** threshold

p106 E2 **N>Nx OFF** threshold

Freely programmable speed thresholds to set the corresponding bits in E1 or E2 state.

If $|N \text{ actual value}|$ (P051) is greater than N>Nx ON threshold, then bit no. 11 is enabled and disabled if $|N \text{ actual value}|$ falls below N>Nx OFF threshold.

The input value is related to P019 maximum speed.

P046 E1 **overspeed**

P239 E2 **overspeed**

Threshold value for overspeed monitoring.

The input value is related to P019 maximum speed.

If the set value is exceeded the bit no. 6 is enabled in E1 or E2 state. The bit is disabled if the speed drops below the threshold (no hysteresis).

7.14 Field angle monitoring and Sin²Cos²-monitoring

By using the field angle monitoring, if you have synchronous motors equipped with resolvers or SinCos encoders, you can detect pulse dropouts or "surplus" pulses at the encoder inputs. If these distortions occur repeatedly, the field angle of the field orientation may deviate increasingly. This will have the same effect as a "false" notch position. If you perform a deviation of $\pm 45^\circ$ with a field angle monitoring being active, an error is generated and the controller will be blocked.

The Sin²Cos²-monitoring acts for resolver and SinCos-encoder as an additional monitoring of wire break within the encoder line. If you have resolver or SinCos-encoders, the Sin²Cos²-monitoring calculates the amplitudes out of the sinus- and cosinus tracks by drawing the square root out of $((\sin x)^2 + (\cos x)^2)$. Under normal circumstances, the value will reach 80 %. If these calculations show the result, that exceeds the Sin²-upper limit or is less than 20 %, an error will be generated if the monitoring has been activated (see also P240).



NOTE

The field angle monitoring and the Sin²Cos²-monitoring require SW14.07 or higher.

Parameter overview

Parameter	Name	Range min. ... max.	Unit	Display only
P025	see "Evaluation Encoder 1 and Encoder 2" on page 108.			
P040	see "Evaluation Encoder 1 and Encoder 2" on page 108.			
P240	see "Evaluation Encoder 1 and Encoder 2" on page 108.			
P241	see "Evaluation Encoder 1 and Encoder 2" on page 108.			
P570	G1 sine ² x-upper limit	85 ... 110	%	
P571	G2 sine ² x-upper limit	85 ... 110	%	
P572	GM field angle monitoring threshold	0 ... 40	%	

Parameter description

P570 G1 sine² upper limit

P571 G2 sine² upper limit

With these parameters, the upper limit for the Sin²Cos²-monitoring is adjusted.

The Sin²Cos²-monitoring calculates the amplitudes out of the sinus- and cosinus tracks by drawing the square root out of $((\sin x)^2 + (\cos x)^2)$. Under normal circumstances, the value will reach 80 %. If these calculations show the result, that a value exceeds the Sin²-upper limit or a value is less than 20 %, an error will be generated if the monitoring has been activated.

Recommended values:

SinCos encoder 95%

Resolver 100%

Default value = 95 %

P572 GM field angle monitoring threshold

The calculated model field angle corresponds motor dependant to the real field angle from a certain speed. This parameter sets the speed threshold, related to parameter P019 maximum speed, from that threshold the calculation of the field angle starts. The field angle monitoring compares the field angle of synchronous motors with resolver or SinCos encoder with a calculated model value and generates an error if the deviation is larger than +/- 45°.

Recommended values:

Default value = 20 %

To calculate the model angle more precisely, the setting of parameter P299 leakage inductance is advantageous.

7.15 Current Controller

Parameter overview

Parameter	Name	Range		Unit	Display only
		min.	max.		
P079	I state	0000	FFFF		×
P080	I P gain	0,1	63,9		
P081	I integral action time	0.0	1000,0	ms	
P067	I M set value	-100,00	100,00	%	
P048	I M additional set value	-100,00	100,00	%	
P071	I I _q set value	-100,00	100,00	%	
P072	I I _q actual value	-199,99	199,99	%	×
P068	I I _q controller output	-100,00	100,00	%	×
P069	I EMC set value	-100,00	100,00	%	×
P075	I U _q set value	-100,00	100,00	%	×
P077	I I _d set value	-100,00	100,00	%	
P078	I I _d actual value	-199,99	199,99	%	×
P076	I U _d set value	-100,00	100,00	%	×
P070	I phase voltage U	-100,00	100,00	%	×
P086	I phase voltage V	-100,00	100,00	%	×
P073	I phase voltage U	-100,00	100,00	%	×
P074	I phase current V	-100,00	100,00	%	×
P083	I current offset U	-25,00	25,00	%	×
P084	I current offset V	-25,00	25,00	%	×
P099	I current actual value	0,00	100,00	%	×
P0576	I NF center frequency (from SW 14.09)	0,000	8,000	kHz	
P0577	I NF bandwidth (from SW 14.09)	0,010	2,000	kHz	

Parameter description

P079 | state

This parameter indicates the status of the internal function module.

Bit No.	Meaning
0 ... 2	000: STOP (controller inhibited) 001: RUN (controller enabled) 011: STAND_BY (direct-axis current controller inhibited, field has been set-up) 101: INIT (direct-axis current controller enabled, field is being set-up)
3	Error in module
4	0: Current control on synchronous machine 1: Current control on asynchronous machine
5	0: No field available 1: Field is available In the case of the asynchronous machine, after $3 \times P293$ (rotor time constant T_v) has expired, the direct-axis current, P078, must be at least 80% of the direct-axis current P077. After this, the system does not continuously monitor the in-phase regulator.
6 ... 15	Reserve

P080 | P gain

P081 | integral action time

This parameters set the P gain (k_p) and the integral action time (T_N) of the direct-axis current controller and the wattless current controller.

Setting of the current controller:

MM stator resistance P298 = 0 or MM leakage inductance P299 = 0

The current prediction is switched off, the controller parameter k_p and T_N can be set as usual.

If the motor parameter stator resistance and leakage inductance are known, the current controller can be set the following way:

Setting of the SM's current controller

- MM mode bit no. 3 = 0 P269
(0 : SM)
- MM stator resistance = 0 P298
MM leakage inductance = 0 P299

$$\bullet \quad T_n = T_s = \frac{I_s}{r_s} \quad \text{and} \quad k_p = \frac{I_s}{3 \cdot T_{ab}} \cdot \frac{I_{\max}(P113)}{\frac{U_{zKnom}(P087)}{\sqrt{6}}}$$

$$T_{ab} = 0,5 \cdot \frac{1}{f_s(P103)}$$

The current controller is set according the absolute value optimum.

- Set MM stator resistance r_s P298
Set MM leakage inductance I_s P299
- Double k_p

Setting of the AM's current controller

- MM mode bit no. 3 = 1 (1 : AM) P269
- MM mode bit no. 2 = 1 (torque after 3*T_R available) P269
- MM stator resistance = 0 P298
MM leakage inductance = 0 P299
- $T_n = T_s = \frac{\sigma l_s}{r_s}$ and $k_p = \frac{\sigma l_s}{3 \cdot T_{ab}} \cdot \frac{I_{max}(P113)}{\frac{U_{ZKnom}(P087)}{\sqrt{6}}}$

$$T_{ab} = 0,5 \cdot \frac{1}{f_s(P103)}$$

The current controller is set according the absolute value optimum.

The leakage inductance σl_s for AM is very important for a stable operation within the field weakening range. It can be calculated from motor data:

$$\sigma l_s = \frac{X\sigma_1 + X\sigma_2}{2 \cdot \pi \cdot f_{nom}(P263)} \cdot 1000 \text{ mH}$$

- Set MM stator resistance r_s P298
and MM leakage inductance σl_s P299
- Double k_p

If the leakage inductance is not known, it can be found out the following way:

- MM stator resistance = 0 P298
MM leakage inductance = 0 P299
- Operation mode speed control P122
- Calculate leakage inductance σl_s approximately and enter the value:

$$\sigma l_s = \frac{\frac{U_{nom}}{\sqrt{3}} \cdot 5 \%}{2 \cdot \pi \cdot f_{nom}(P263) \cdot I_d(P260)} \cdot 1000 \text{ mH} \quad P299$$

U_{nom} : nominal voltage between lines of the motor

- Vary speed set value periodically between 90 % and 100 % of nominal speed
- Change P299 MM leakage inductance slowly, until the current I_d actual value (P078) is almost constant while torque change.
If the current I_d (P078) actual value is higher during acceleration or braking, the inductance P299 must be increased. In the other case its value must be reduced.
- Set MM Ständerwiderstand. P298
- After finding out of the inductance the current controller can be set see setting of the AM's current controller.

PO67 | M set value

Set value input for current control mode (P122 = -2)

Standardization: 100 % ↔ PU I limit (P116)

P048 | M additional set value

Additional set value for all modes.

Standardization: 100 % ↔ PU I limit (P116)

The effective torque set value is the sum of M set value and M additional set value.

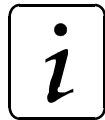
**NOTE**

The time needed to enable the rated torque value depends on the setting of the P269 MM mode bit no. 2.

P071 | I_q set value**P072 | I_q actual value**

The cross current specified/actual value (torque forming current component of the vector control) is indicated here. 100 % corresponds to the value set in the LT I limit (P116).

P068 | I_q controller output

Manipulated variable of wattless current controller.

Standardization: 100 % ↔ $\frac{U_{ZKnom}(P087)}{\sqrt{3} \cdot \sqrt{2}}$

P069 | EMC set value

Voltage set value from motor model, corresponds with machine's EMC.

Standardization: 100 % ↔ $\frac{U_{ZKnom}(P087)}{\sqrt{3} \cdot \sqrt{2}}$

P075 | U_q set value

Sum of P068 I_q controller output and P069 EMC set value.

Standardization: 100 % ↔ $\frac{U_{ZKnom}(P087)}{\sqrt{3} \cdot \sqrt{2}}$

P077 | I_d set value

P078 | I_d actual value

The direct-axis current set value / actual value is displayed here.

Standardization: 100 % ↔ PU I limit (P116)

P076 | U_d set value

Manipulated variable of direct-axis controller..

Standardization: 100 % ↔ $\frac{U_{ZKnom}(P087)}{\sqrt{3} \cdot \sqrt{2}}$

P070 | phase voltage U

P086 | phase voltage V

This parameter displays the voltage set value of phase U or V.

Standardization: 100 % ↔ $\frac{U_{ZKnom}(P087)}{\sqrt{3} \cdot \sqrt{2}}$ (rms value)

P073 | phase current U

P074 | phase current V

Standardization: 100 % ↔ PU I limit (P116)

P083 | current offset U

P084 | current offset V

To compensate the offset of the current transformer, the current transformer is set to 0 at every pulse enabling. This parameter shows the offset value.

Standardization: 100% ↔ 2^{11} (half of the measuring transducer range)

P099 | current actual value

Standardization: 100 % ↔ PU I limit (P116)

P576 | NF center frequency (from SW 14.09)

P577 | NF bandwidth (from SW 14.09)

The notch filter (band rejection filter) is used to eliminate undesired frequencies in P071 | I_q set value.

With a controller frequency of 16 kHz (at 8 kHz pulse frequency) the center frequency can be changed theoretically in the range between 0 kHz and 8 kHz.

With a controller frequency of 8 kHz (at 4 kHz pulse frequency) the center frequency can be changed theoretically in the range between 0 kHz and 4 kHz.



NOTE

The notch filter is switched off, when center frequency = 0 (standard value)

It must always be valid:

$$\frac{\text{Center frequency}}{2} \geq \text{band width}$$

The following figure displays the amplitude characteristic of the notch filter with a center frequency of 1 kHz and a bandwidth of 0,5 kHz. The amplification of the notch filter is 0 at the center frequency.

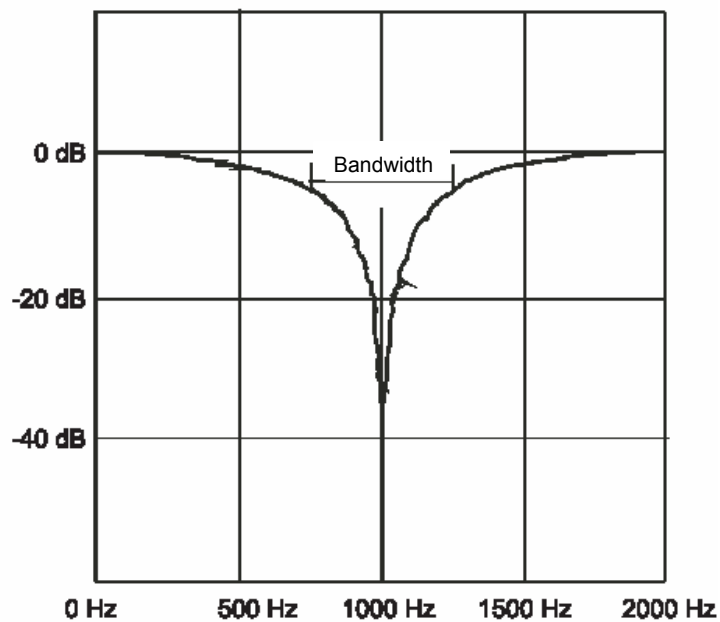

7.16 Speed Controller

Parameter overview

Parameter	Name	Range min. ... max.	Unit	Display only
P059	N state	0000 ... FFFF		×
P057	N P gain	0,1 ... 1000,0		
P058	N integral action time	0,0 ... 2000,0	ms	
P049	N J compensation	0 ... 30000		
P050	N set value	-100,00 ... 100,00	%	
P047	N additional set value	-100,00 ... 100,00	%	
P051	N actual value	-199,99 ... 199,99	%	×
P052	N controller output	-100,00 ... 100,00	%	
P038	N M limiter mode	0 ... 1		
P053	N M limiter bipolar	0,00 ... 100,00	%	
P054	N M limiter Mot/TD1	0,00 ... 100,00	%	
P055	N M limiter Gen/TD2	0,00 ... 100,00	%	
P060	N deviation	-199,99 ... 199,99	%	×
P061	N limiter deviation	0,00 ... 199,99	%	
P056	N block time	0,0 ... 360,0	s	

Parameter description

P059 N state

This parameter shows the speed controller's state.

Bit no.	Meaning
0 ... 2	000: STOP, N controller disabled 001: RUN, N controller enabled 011: STAND_BY, N disabled, block monitoring enabled
3	1: Error in module. Error code see P124
4	1: Drive is blocked (block monitoring time P056 active)
5 ... 9	reserved
10	0: motor-operated mode 1: generator-operated mode
11	0: torque direction 1 active 1: torque direction 2 active
12	1: set value reached ($ \text{Deviation P060} < \text{limiter deviation (P061)}$)
13	1: limiter set value reached (current limiter)
14 ... 15	reserved

P057 N P gain

P gain (K_p) of speed controller.

P058 N integral action time

Integral action time (T_N) of speed controller.

P049 N J compensation

Moment of inertia compensation.

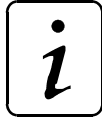

NOTE

A J-compensation is not possible with an analog speed selection

P047 N additional set value

P050 N set value

Set value inputs for speed controller (see also "Overview V-Controller" on page 64)

Standardization: 100 % ↔ GM maximum speed (P019)

P051 N actual value

Speed actual value of encoder 1 or encoder 2 (depends on P226 EM mode bit no. 1).

Standardization: 100 % ↔ EM maximum speed (P019)

P052 N controller output

This parameter shows the set value of speed controller.

Standardization: 100 % ↔ PU I limiter (P116)

P038 N M limiter mode

This parameter switches between torque limiter motor-operated/generator-operated and torque direction TD1/TD2.

Value	Meaning
0	torque limiter Mot/Gen
1	torque limiter TD1/TD2

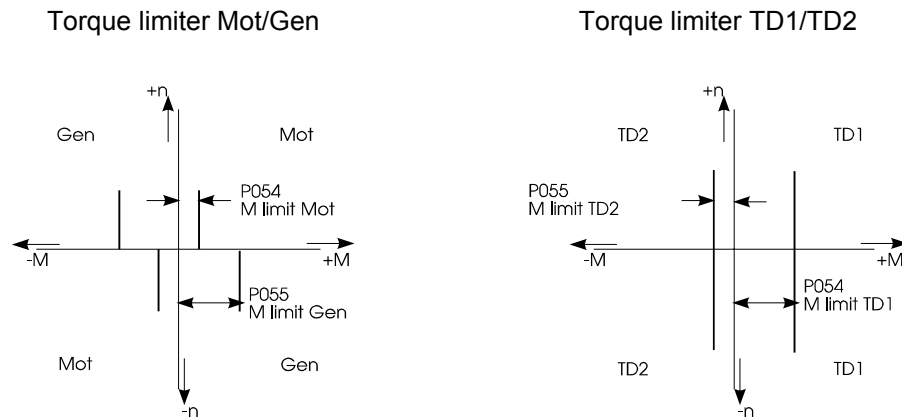

P053 N M limiter bipolar

P054 N M limiter Mot/TD1

P055 N M limiter Gen/TD2

The control value is symmetrically limited with the bipolar limiter. From the bipolar, Mot/TD2 and Gen/TD2 limiter, the respective smaller value is valid. If the I²t power unit monitoring operates, the torque limiter are internally restricted to 100 %. During the limitation bit no. 15 in N state is set.

Standardization: 100 % ↔ PU I limit (P116)

P060 N deviation

This parameter displays the actual speed controller deviation.

Standardization: 100 % ↔ EM maximum speed (P019)

P061 N limiter deviation

If the value falls below the maximum deviation set by this parameter, the function module transmits the message set value reached (bit no. 12 in N state P059 is set).

Standardization: 100 % ↔ EM maximum speed (P019)

P056 N block time

This parameter sets the time of the block monitoring.

The block monitoring is active, if the speed controller is on the current limit (N state, bit no. 13 = 1) and simultaneously the N = 0 message (EM state, bit no. 10 = 1) is active. During this state is active, the bit no. 4 in N state is set.

After the block monitoring time is over, the controller is disabled with error message 0702_{hex}. If block time = 0,0 s the block monitoring is not active.

7.17 Torque Monitoring

Function

This function module compares the current actual value with different limits.

Correction factor (from SW 14.07)

This corrects the display values P066 TM M loading and P092 TM Mact/Mnom e.g. for extrusion machines. There the torque actual value is a control variable and is required with a higher accuracy.

Correction formula: $M_{corr} = k1 * M - k2 * n + k3$

M_{corr} = corrected display value of P066 TM M loading and P092 TM Mact/Mnom

M = original torque actual value

n = speed (speed actual value)

k1 = correction factor 1 (P562)

k2 = speed-dependent correction factor 2 (P563)

k3 = offset correction factor 3 (P564)



NOTE

If the correction factors are set to its default values, the parameter values P066 TM M loading and P092 TM Mact/Mnom are equal to the software versions before 14.07.

Parameter overview

Parameter	Name	Range min. ... max.	Unit	Display only
P098	TM state	0000 ... FFFF		×
P065	TM mode	0000 ... 0003		
P096	TM M > Mx1	0,00 ... 100,00	%	
P097	TM time 1	0,000 ... 60,000	s	
P094	TM M > Mx2	0,00 ... 100,00	%	
P095	TM time 2	0,000 ... 60,000	s	
P066	TM M loading	to SW 14.07 -100,00 ... 100,00 from SW 14.08 -199,99 ... 199,99	%	×
P092	TM Mact / Mn	to SW 14.07 -100,00 ... 100,00 from SW 14.08 -199,99 ... 199,99	%	×
P562	TM corr. factor 1	0.0001 ... 3,2767	-	
P563	TM corr. factor 2	0.0000 ... 3,2767	-	
P564	TM corr. factor 3	-10.00 ... +10.00	%	

Parameters

Parameter description

P098 TM state

This parameter shows the function module's state.

Bit no.	Meaning
0 ... 2	001: RUN, monitoring active
3	reserved
4	M loading (P066) > threshold 1 (P096)
5	time 1 is expired
6	M loading (P066) > threshold 2 (P096)
7	time 2 is expired
8 ... 15	reserved

P065 TM mode

This parameter sets the display of the parameters P066 M loading and P092 Mact/Mn.

Bit no.	Meaning
0	1 : absolute value display active
1	1 : sign change active
2 ... 15	reserved

P096 TM $M > M1$

P097 TM time 1

P094 TM $M > M2$

P095 TM time 2

This parameters define the function of the torque monitoring. The thresholds are related to the absolute value of the torque capacity.

The hysteresis is each time 3 % of set threshold.

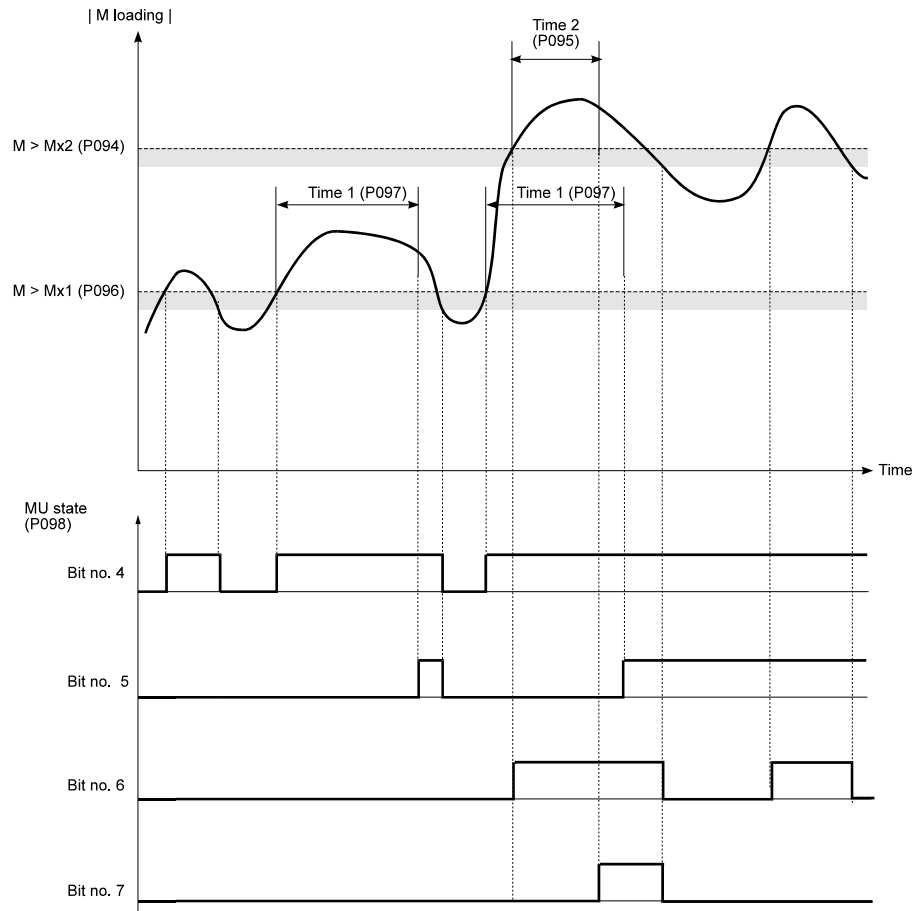

P066 TM M loading

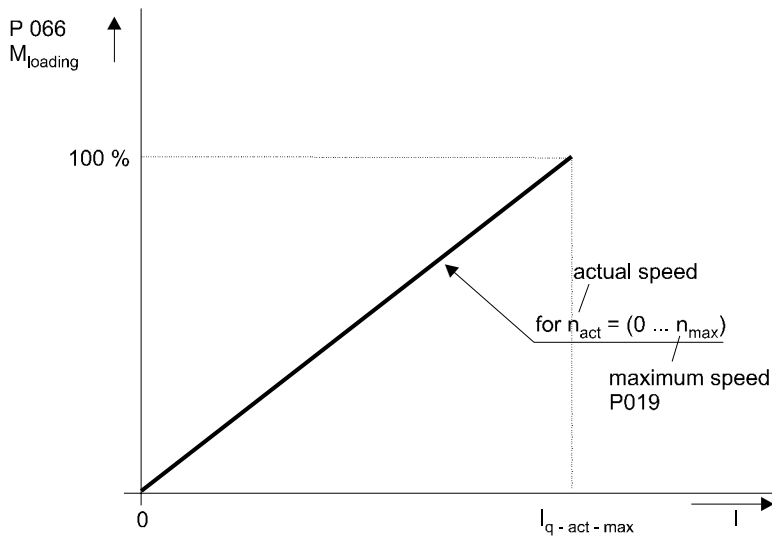

P092 TM M_{act} / M_n

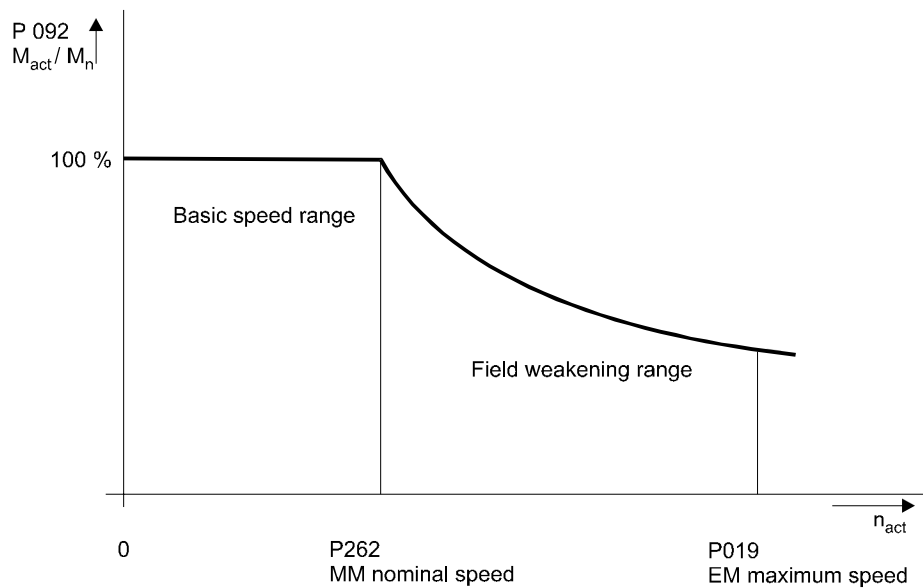

P562 TM corr. factor 1

Corresponds with k_1 (4 decimal places).

P563 TM corr. factor 2

Corresponds with k_2 (4 decimal places).

P564 TM corr. factor 3

Corresponds with k_3 (2 decimal places).

7.18 Position Controller

Function

The position controller module is a P-Controller for position control of the unit. The module contains multi-turn evaluation of the motor position encoder, the set value interpolator, speed precontrol as well as control variable limiting and the dynamic and static deviation.



NOTE

The efficiency of the position control is directly dependent upon the efficiency of the speed control.

Parameter overview

Parameter	Name	Range min. ... max.	Unit	Display only
P200	P state	0000 ... FFFF		×
P201	P mode	0000 ... 0007		
P202	P Kv factor	0 ... 32000	1/s	
P207	P N precontrol	0,00 ... 125,00	%	
P213	P N precontrol smoothing	0,0 ... 50,0	ms	
P220	P N precontrol output	-100,00 ... 100,00	%	
P211	P controller output	-100,00 ... 100,00	%	×
P208	P set value	00000000 ... FFFFFFFF	Inc	
P209	P actual value	00000000 ... FFFFFFFF	Inc	
P210	P deviation	80000001 ... 7FFFFFFF	Inc	×
P205	P rev set value	00000000 ... FFFFFFFF		
P206	P phi set value	00000000 ... FFFFFFFF		
P218	P rev actual value	00000000 ... FFFFFFFF		
P219	P phi actual value	00000000 ... FFFFFFFF		
P204	P N limit bipolar	0,00 ... 100,00	%	
P212	P deviation limit static	00000000 ... 7FFFFFFF	Inc	
P203	P deviation limit dynamic	00000000 ... 7FFFFFFF	Inc	
P214	P deviation time	0,000 ... 65,000	s	
P216	P gear factor	0,1 ... 1000,0		
P217	P deviation phi	80000001 ... 7FFFFFFF	Inc	×

Parameter description

P200 P state

This parameter shows the actual position controller's mode.

Bit no.	Meaning
0 ... 2	000 : STOP Position controller disabled 001 : RUN Position controller enabled
3	1 : Error in position controller, error code see P124
4	1 : Dynamic deviation limiter exceeded
5	1 : Static deviation limiter exceeded
6	1 : Timeout dynamic deviation limiter
7	1 : Timeout static deviation limiter
8 ... 11	reserved
12	1 : Set value reached (bit nos. 4 and 5 are not set)
13	1 : Position controller on limit
14 ... 15	reserved

P201 P mode

This parameter sets the position controller's operational mode.

Bit no.	Meaning
0	1 : Enabling error dynamic deviation
1	1 : Enabling error static deviation
2	1 : Position measurement on load 0 : Position measurement on motor The bit can only be changed, if the position controller's state is STOP
3 ... 15	reserved

See P deviation limiter dynamic (P203) and P deviation limiter static (P212).

The change of position actual value monitoring (bit no. 2) is only possible if controller is disabled. For further notes see function module encoder 1 and encoder 2 as well as encoder manager.

P202 P Kv factor

The position controller is implemented as P controller. The k_V factor is the gain of the position controller. If $k_V = 0$ the position controller is inactive, because each controller deviation is multiplied by the k_V factor.

P207 P N precontrol**P213 P N precontrol smoothing**

The speed precontrol is implemented as DT1 element. Each change of position set value are differentiated with respect to time, multiplied by parameter N precontrol and then smoothed with the time constant in P213. If N precontrol = 0 % the speed precontrol has no effect in the speed set value (P050).

If N precontrol = 100 % and position set value change is constant per time unit, the speed precontrol supplies the exact needed speed set value. The position controller supplies in this case only the correcting set value to follow the angle.

P220 P N precontrol output

Output value of N precontrol..

Standardization: 100 % ↔ Maximum speed P019

P211 P controller output

Output value of position controller.

Standardization: 100 % ↔ Maximum speed P019

The speed set value P050 is put together from controller output P211 and the speed precontrol P220.

It is limited to the value in P204. As long as the set value is limited, the bit no. 13 in state P200 is set.

P208 P set value

Set value input of the position controller. The position set value is initialized to the position actual value of the chosen encoder system at first pulse enabling. At further pulse enabling the position actual value (P209) is set. If a drive profile is set via L set value, the maximum position change permitted is limited.

At P103 frequency = 4 kHz $|L \text{ set value}_{\text{new}} - L \text{ set value}_{\text{old}}|$ is max. $7\text{FFFF}_{\text{hex}}$.

At P103 frequency = 8 kHz $|L \text{ set value}_{\text{new}} - L \text{ set value}_{\text{old}}|$ is max. $\text{FFFFFF}_{\text{hex}}$.

P209 P actual value

This parameter displays the position actual value.

Past the first pulse enabling of the controller the position set value is initializes on the resolver or incremental encoder angle after that independent from the actual M desired operation mode (P122) and independent from the status of the state machine (P121) the actual value is permanent actualized.

It is possible to write to the position actual value in every operation mode.

Calibration of position set and actual value:

One motor revolution corresponds with internal **65536** increments. The low word represents the motor angle the high word counts the whole revolutions.

P210 P deviation

The difference between position set value (P208) and actual value (P209) is termed deviation. Reasons for large deviations could be: blocked motor, not achievable set speed or wrong inputs of controller parameters (e.g. speed controller).

The calibration corresponds to the position set/actual value standardization.

P205 P rev set value

P206 P phi set value

64 bit position set value. 32 bit for whole revolutions (P205) and 32 bit for angle (P206). This parameters cannot be used for setting a drive profile.

P218 P rev actual value

P219 P phi actual value

Copy of 64 bit position actual value from encoder 1 respectively encoder 2 (select P Mode P201 bit no. 2)

P204 P N limiter bipolar

This parameter limits symmetrically the position control set value (speed set value) . As long as the set value limitation is active, the bit no. 13 in state (P200) is set.

Deviation monitoring

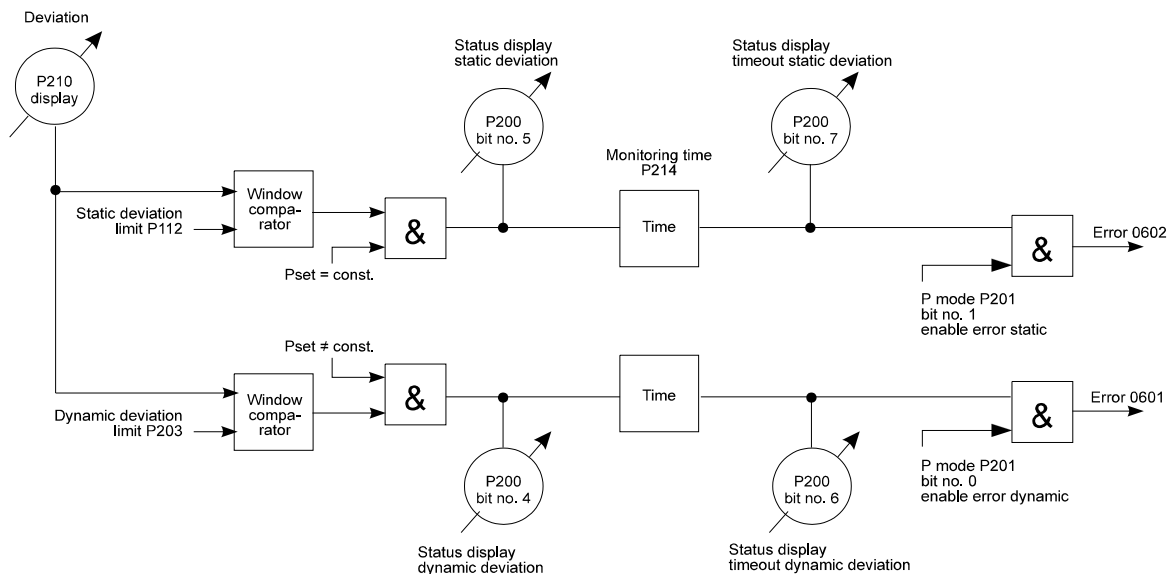

P212 P deviation limiter static

The static deviation limiter is active, if the position controller no position set value received or the position set value doesn't change (see diagram P203).

The static deviation limiter symmetrically limits the set position value.

If the actual deviation is greater than the entered dynamic deviation limiter, bit no. 5 is set in P state (P200).

After the monitoring time (P time, P214) the bit no. 7 is additionally set and the error code 0602_{hex} (see P124 M error code) is generated. The drive changes to the state inhibit start if in parameter P mode (P201) the error dynamic deviation is enabled (Bit no. 1 = 1).

P203 P deviation limiter dynamic

The dynamic deviation limiter symmetrically limits the set position value. If the actual deviation greater than the entered dynamic deviation limiter, bit no. 4 is set in P state (P200). After the monitoring time (P time, P214) the bit no. 6 is additionally set and the error code 0601_{hex} (see P124 M error code) is generated. The drive changes to the state inhibit start if in parameter P mode (P201) the error dynamic deviation is enabled (bit no. 0 = 1).

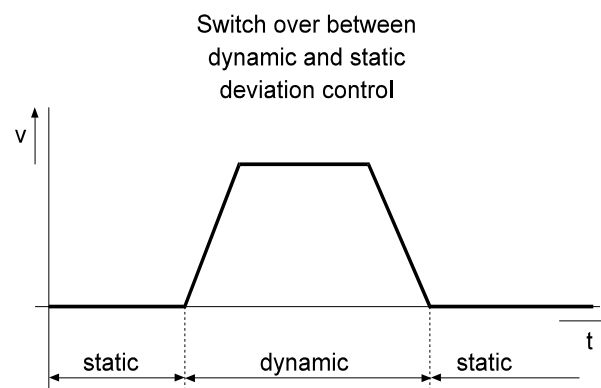

P214 P time

This parameter sets the time window of the deviation monitoring. The delay time is only active, if bit no. 6 and 7 in P state is set.

P216 P gear factor

After the position controller a gear has been implemented.

Application example with gear factor:

P216 P gear factor	$\omega 1:\omega 2$
P226 EM mode	Bit no. 0 = 0: Angle and speed are given by encoder 1.
P040 E1 mode	Set according encoder 1 at the motor.
P241 E2 mode	Set according encoder 2 at the load.
P210 P mode	Bit no. 2 = 1: Position measurement at the load

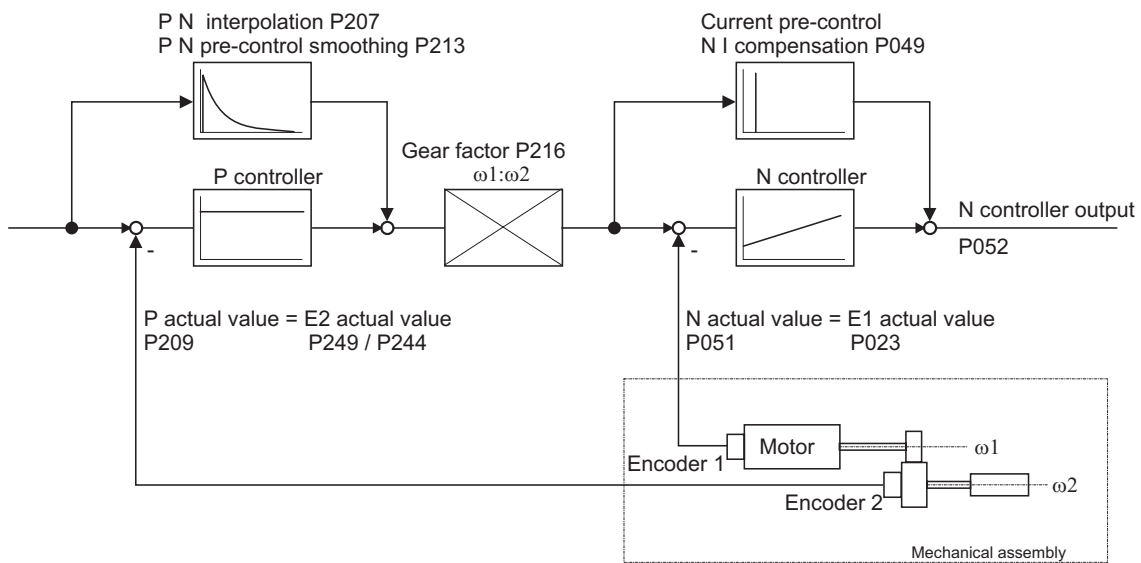

P217 P deviation Phi

This parameter increases the resolution of the angle position of parameter P210 P deviation. The maximum deviation displayed on this parameter is \pm half a revolution.

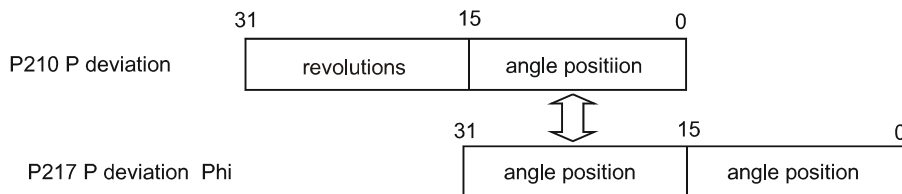

NOTE

Requires SW 13.12 or higher resp. SW 14.07 or higher.

Position data formats overview

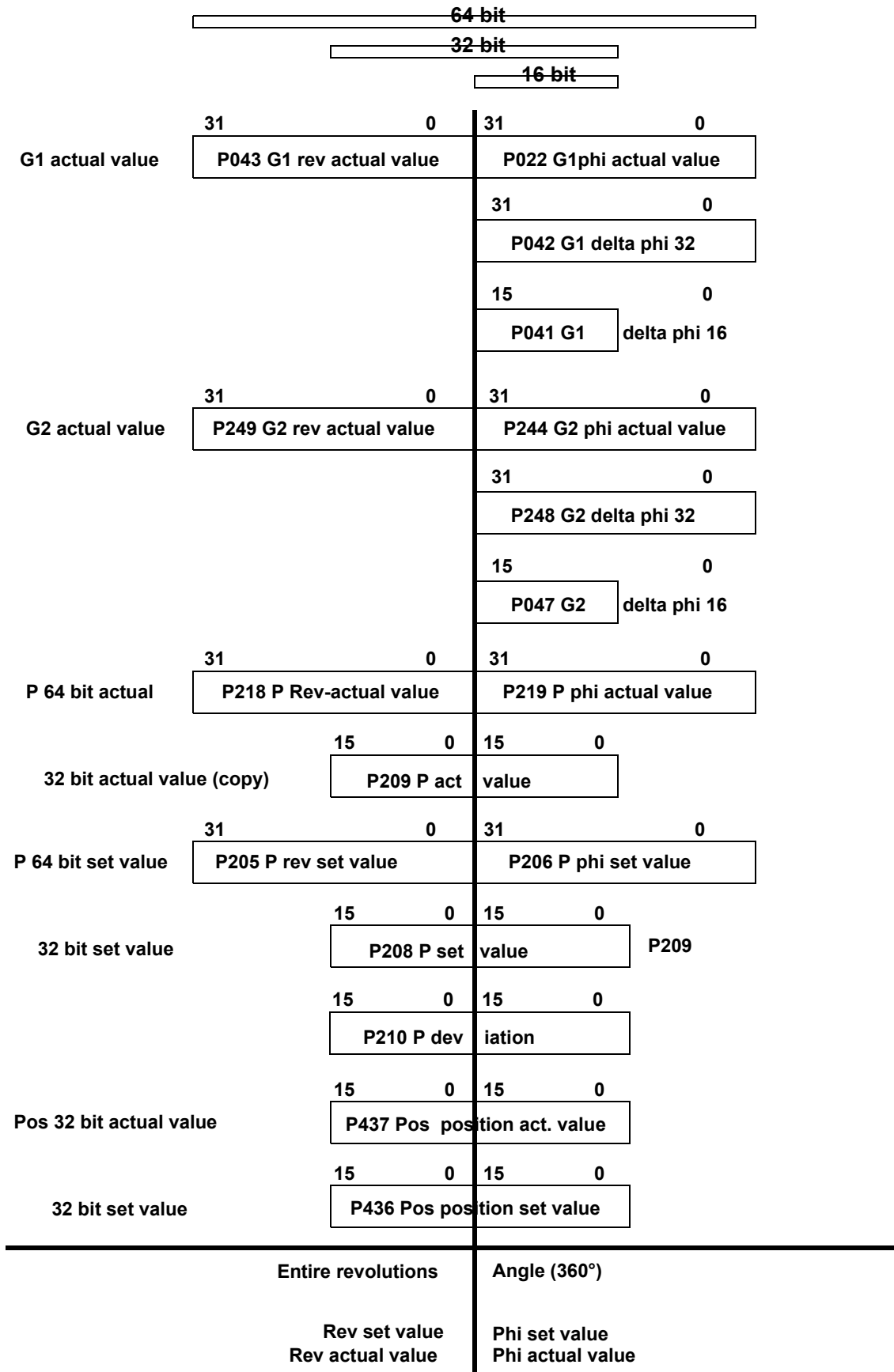

7.19 Drive Manager

Function

The drive manager administrates the essential system resources of the drive. These include among others complete unit control in various modes, switching between the different modes, the management of all communication interfaces, error treatment etc.

Parameter overview

Parameter	Name	Range min. ... max.	Unit	Display only
P120	M control word	0000 ... FFFF		
P121	M state word	0000 ... FFFF		×
P122	M desired operation mode	-6 ... 6		
P123	M actual operation mode	-6 ... 6		×
P124	M error code	0000 ... FFFF		×
P125	M error index	0 ... 31		×
P136	M mode	0000 ... 0007		
P126	M communication source	0000 ... 000F		
P127	M communication monitoring	0000 ... 000F		
P128	M monitoring time	0 ... 60 000	ms	
P129	M monitoring code	-2 ... 3		
P130	M HALT code	0 ... 3		
P131	M RAPID HALT code	0 ... 3		
P132	M INHIBIT no. code	0 ... 3		
P133	M SHUTDOWN code	0 ... 3		
P134	M state bit no. 14	0000 ... FFFF		×
P135	M state bit no. 15	0000 ... FFFF		×
P137	M state 1	0000 ... FFFF		×
P188	M error reaction time	0,00 ... 650,0	s	
P189	M error reaction code	0 ... 3		

- Introduction to the representation of unit control

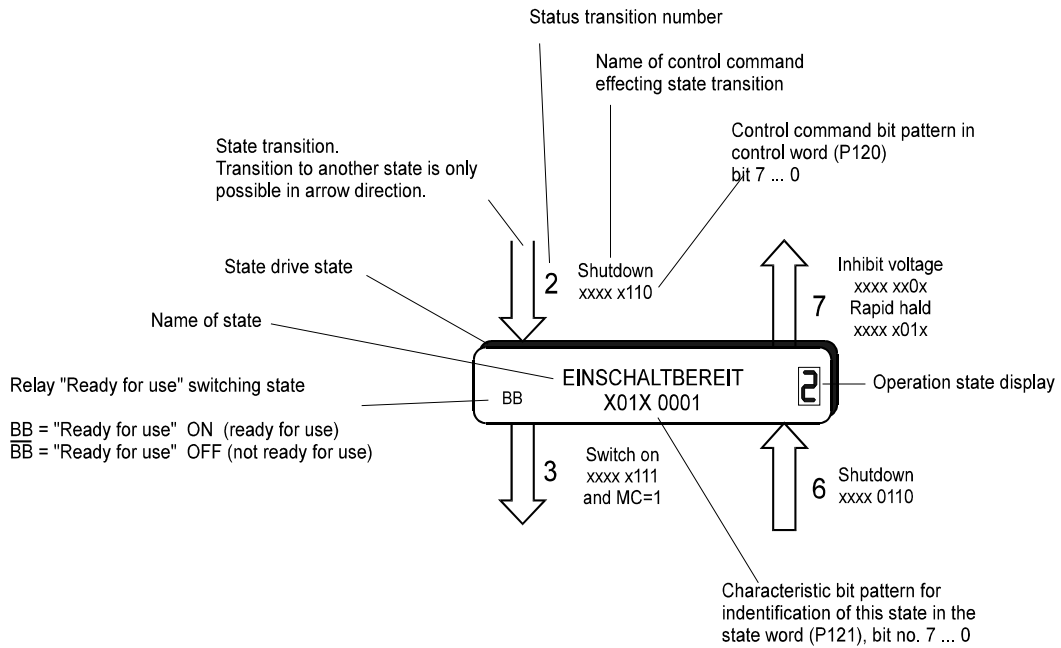

The binary bits 7 ... 0 of the static drive state (P121) are figured XXXX XXXX. The state transition bit pattern of the control word (P120) is figured xxx xxx (bit no. 7 ... 0).

The bits designated with X or x have no effect on the unit state.

- Unit control state machine

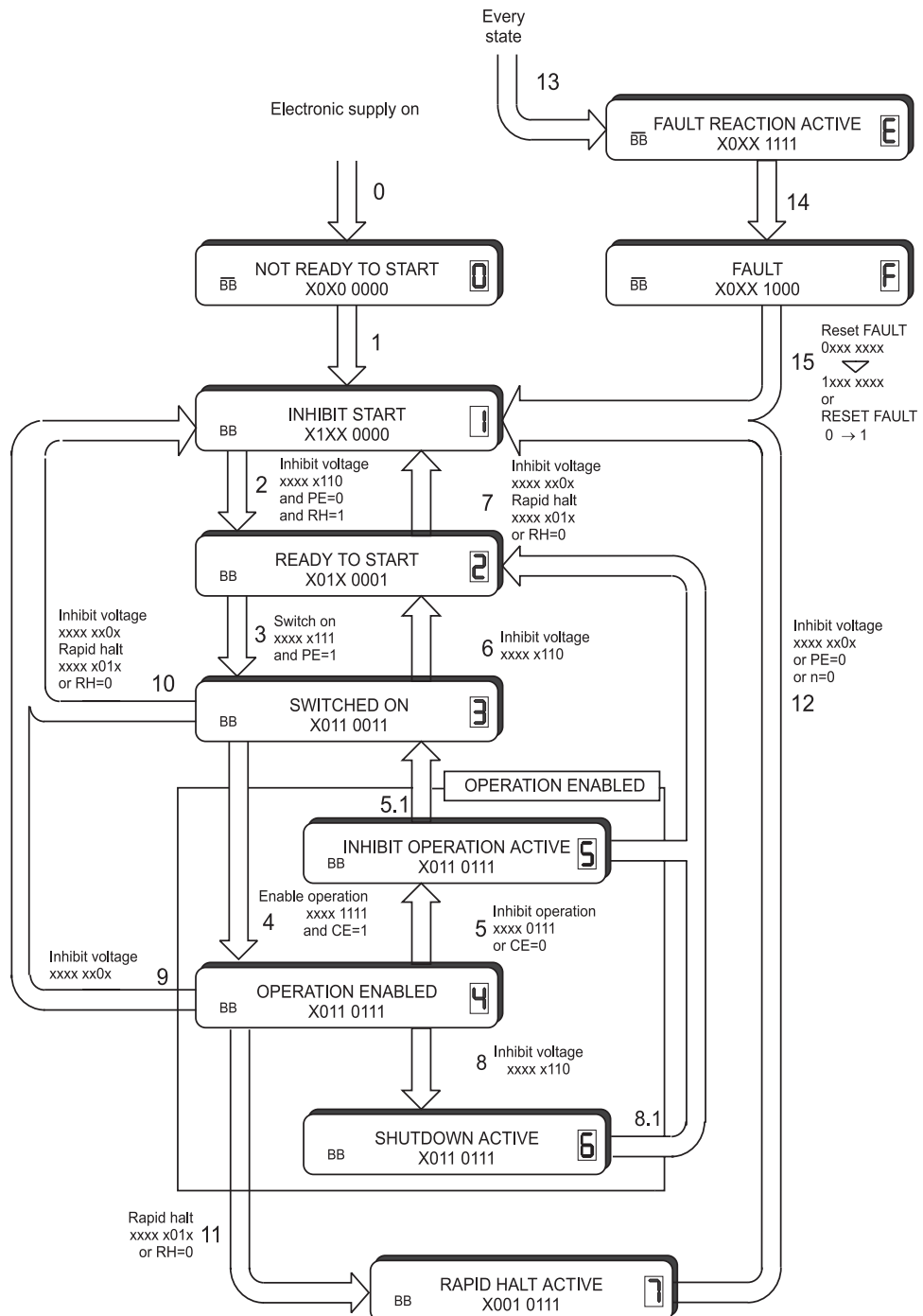

PE = 1: Pulse enabling (X26:14 = High)
 PE = 0: Pulse enabling (X26:14 = Low)

RH = 1: Rapid halt inactive (X26:19 = High)
 RH = 0: Rapid halt active (X26:19 = Low)

CE = 1: CONTROLLER ENABLING high
 CE = 0: CONTROLLER ENABLING low

- **Unit control states**

0 NOT READY TO START

- electronics supplied with voltage
- self-test running
- initialisation running
- drive function inhibited
- relay „ready for use“ is off (drive not ready for use)

1 INHIBIT START

- software/hardware initialisation completed
- parameter assignment completed
- drive function inhibited
- switch-on inhibited
- relay „ready for use“ is on (drive ready for use)

2 READY TO START

- application parameters can be redefined
- drive function inhibited
- switch-on enabled
- relay „ready for use“ is on (drive ready for use)

3 SWITCHED ON

- application parameters can be redefined
- drive function inhibited
- power unit ready for use
- relay „ready for use“ is on (drive ready for use)

4 ENABLE OPERATION

- application parameters can be redefined
- drive function enabled
- relay „ready for use“ is on (drive ready for use)

5 INHIBIT OPERATION ACTIVE

- application parameters can be redefined
- drive function enabled
- command „Inhibit operation“ is active (can be set in M shutdown code P132)
- relay „ready for use“ is on (drive ready for use)

6 SHUTDOWN ACTIVE

- application parameters can be redefined
- drive function enabled
- command „Shutdown“ is active (can be set in M shutdown code P132)
- relay „ready for use“ is on (drive ready for use)

7 RAPID HALT ACTIVE

- application parameters can be redefined
- rapid halt function is carried out (parameter assignment via M rapid halt code, P131)
- drive function enabled
- relay „ready for use“ is on (drive ready for use)

E FAULT REACTION ACTIVE

- application parameters can be redefined
- an fault-dependant action is carried out
- drive function may be enabled

F FAULT

- application parameters can be redefined
- drive function inhibited
- relay „ready for use“ is off (drive not ready for use)

- **Unit control state transitions**

<p>0 State machine input event: action:</p>	<p>or or</p>	<p>→ NOT READY TO START 0 - hardware reset - software reset - switch on operating voltage - switch off relay „ready for use“ - start self-test</p>
<p>1 NOT READY TO START event: action:</p>	<p>0</p>	<p>→ INHIBIT START 1 - error-free completion of initialisation and self-test - activate communication and process data monitoring - switch on relay „ready for use“</p>
<p>2 INHIBIT START event: condition: action:</p>	<p>1</p>	<p>→ READY TO START 2 - command „shutdown“ - rapid halt input X26:19 = high - pulse enabling X26:14 = low - none</p>
<p>3 READY TO START event: condition: action:</p>	<p>2</p>	<p>→ SWITCHED ON 3 - command „switch on“ - rapid halt input X26:14 = high - switch on power unit, if not on yet - monitoring „ready for use“ signal of power supply</p>
<p>4 SWITCHED ON event: condition: action:</p>	<p>3</p>	<p>→ OPERATION ENABLED 4 - command „enable function“ - CONTROLLER ENABLING input = high - enable drive function</p>
<p>5 OPERATION ENABLED event: action:</p>	<p>4 or</p>	<p>→ SWITCHED ON 3 - command „inhibit operation“ - CONTROLLER ENABLING input = low - inhibit drive function</p>
<p>6 SWITCHED ON event: action:</p>	<p>3</p>	<p>→ READY TO START 2 - command „shutdown“ - pulse enabling input X26:14 = low - the power unit can be switched off - monitoring „ready for use“ signal of power supply is switched off</p>
<p>7 READY TO START event: action:</p>	<p>2 or or</p>	<p>→ INHIBIT START 1 - command „rapid halt“ - command „inhibit voltage“ - rapid halt input X26:19=low - none</p>

<p>8 OPERATION ENABLED event: action:</p>	<p>4</p>	<p>→ READY TO START 2 - command „shutdown“ - inhibit drive function (parameter assignment via M shutdown code P133) - the power unit can be switched off - monitoring „ready for use“ signal of power supply is switched off</p>
<p>9 OPERATION ENABLED event: action:</p>	<p>4</p>	<p>→ INHIBIT START 1 - command „inhibit voltage“ - shutdown drive function - the power unit can be switched off - monitoring „ready for use“ signal of power supply is switched off</p>
<p>10 SWITCHED ON event: action:</p>	<p>3 or or</p>	<p>→ INHIBIT START 1 - command „inhibit voltage“ - command „rapid halt“ - rapid halt input X26:19=low - power unit can be switched off</p>
<p>11 OPERATION ENABLED event: action:</p>	<p>4 or</p>	<p>→ RAPID HALT ACTIVE 7 - command „rapid halt“ - rapid halt input X26:19=low - trigger rapid halt function (parameter assignment via P133)</p>
<p>12 RAPID HALT ACTIVE event: action:</p>	<p>7 or or</p>	<p>→ INHIBIT START 1 - command „inhibit voltage“ - rapid halt completed (n=0) - pulse enabling input X26:14 = low - inhibit drive function - power unit can be switched off - monitoring „ready for use“ signal of power supply is switched off</p>
<p>13 all state types event: action:</p>		<p>→ FAULT REACTION ACTIVE E - drive fault detected - „ready for use“ relay is switched off - trigger error-dependant fault reaction</p>
<p>14 FAULT REACTION ACTIVE event: action:</p>	<p>E</p>	<p>→ FAULT F - fault reaction completed - inhibit drive function - monitoring „ready for use“ signal of power supply is switched off - power unit can be switched off</p>
<p>15 FAULT event: condition: action:</p>	<p>F or</p>	<p>→ INHIBIT START 1 - command „reset fault“ - RESET ERROR input = low → high - error no longer present - fault reset is carried out - switch on „ready for use“ relay</p>

The status only changes if all the actions have been carried out. The sequence of actions corresponds to the sequence of processing during status change. After carrying out all the actions the next status is reached, and new commands are accepted.

- **„Ready for use“ relay**

The state of the relay „ready for use“ changes on the following control transitions:

Transition	Action „ready for use“ relay	Comment
0	switch off	start of drive initialisation
1	switch on	end of drive initialisation
13	switch off	error occurred
15	switch on	all errors are acknowledged, drive without faults

Each state of the drive manager corresponds with a defined state of the „ready for use“ relay.

State	„Ready for use“ relay
NOT READY TO START	OFF
INHIBIT START	ON
READY TO START	ON
SWITCHED ON	ON
OPERATION ENABLED	ON
RAPID HALT ACTIVE	ON
FAULT REACTION ACTIVE	OFF
FAULT	OFF

- **Monitoring „ready for use“ signal of power supply**

The monitoring state is changed only at following states.

Transition	Action	Comment
3	switch on	The time to load the intermediate circuit is considered internally
6 8 9 10 12, 13	switch off	

Each state of the drive manager corresponds with a defined state of the intermediate circuit monitoring.

State	„Ready for use“ relay
NOT READY TO START	OFF
INHIBIT START	OFF
READY TO START	OFF
SWITCHED ON	ON
OPERATION ENABLED	ON
RAPID HALT ACTIVE	ON
FAULT REACTION ACTIVE	OFF
FAULT	OFF

P120 M control word

This parameter corresponds to DRIVECOM object 6040_{hex} and is the input word of the control unit state machine.

Bit no.	Name	Comment
0	switch on	unit control state machine
1	inhibit voltage	unit control state machine
2	rapid halt	unit control state machine
3	enable operation	unit control state machine
4, 5, 6	mode-dependant	see table „total overview of control words“
7	reset fault	unit control state machine
8, 9, 10	reserved	must always be set = 0
11, 12, 13, 14	mode-dependant	see table „total overview of control words“
15	write protection	

The drive managers control word is write protected if the write protection bit (bit no. 15) is set in the control word. After the processing of the write protected control word the drive manager resets the write protection bit to 0.



NOTE

The controller can reach the state „operation enabled“ immediately after the switch on of the electronic power supply, if the control word (see function module drive manager) is manipulated by digital inputs (see function module digital inputs) and the hardware enable is active. During the programming of digital inputs this option must be considered and protective measures have to be ensured on machine-side.

The write protection must be used if the control word is manipulated by digital inputs and a communication source writes simultaneously on the control word.

The unit control commands are defined in the control word via the following bit combinations:

Command	Bit no. 15 write protection	Bit no. 7 reset fault	Bit no. 3 operation enabled	Bit no. 2 * rapid halt	Bit no. 1 * inhibit voltage	Bit no. 0 switch on	Transitions
Shutdown	X	X	X	1	1	0	2,6,8
Switch on	X	X	X	1	1	1	3
Inhibit voltage	X	X	X	X	0	X	7,9,10,12
Rapid halt	1	X	X	0	1	X	7,10,11
Inhibit operation	X	X	0	1	1	1	5
Enable operation	X	X	1	1	1	1	4
Reset fault	X	0 → 1	X	X	X	X	15
Enable operation straight	1	X	1	1	1	1	2

The bits designated with X have no effect on the unit control state.

* low active

Control word: total overview for all modes

Bit no.	Locating position -1	Current control -2	Speed control -3 ¹⁾	Speed specification 1 2 ¹⁾	Position control -4	Manual mode 5	Synchronisation control -5	Reference run mode 6	Target position specification 1	Spindle positioning -6
0	SWITCH ON (state machine)									
1	INHIBIT VOLTAGE (state machine) *									
2	RAPID HALT (state machine) *									
3	ENABLE OPERATION (state machine)									
4	×	×	RFG inhibit	RFG- * inhibit	×	×	×	starting reference run	new set value	×
5	×	×	RFG stop	RFG * stop	×	×	×	×	×	×
6	×	×	RFG-zero	RFG * zero	×	×	×	×	×	×
7	reset fault (state machine)									
8	×	×	×	×	×	×	×	×	×	×
9	×	×	×	×	×	×	×	×	×	×
10	×	×	×	×	×	×	×	×	×	×
11	×	×	×	×	×	inching forward	×	×	start of positioning	×
12	×	×	×	×	×	inching backwards	×	×	×	×
13	×	×	×	×	×	×	×	×	×	×
14	×	×	×	×	×	×	×	×	×	×
15	write protection									

The bits designated with × have no effect on the unit control state.

 * low active

- 1) The bits 4, 5, and 6 have the following priorities in operating modes -3 and 2:
Bit no. 4 before bit no. 5 before bit no. 6

P121 M state word

This parameter corresponds to DRIVECOM object 6041_{hex} and is the output word of the unit control state machine.

Bit no.	Name	Comment
0	READY TO START	state machine
1	SWITCHED ON	state machine
2	OPERATION ENABLED	state machine
3	FAULT	state machine
4	INHIBIT VOLTAGE	bit no. 4 = 0: The „inhibit voltage“ requirement is present (command or main contactor contact)
5	RAPID HALT	state machine
6	INHIBIT START	state machine
7, 8	reserved	reserved
9	remote	bit no. 9 = 1: Parameter can be assigned via the selected communication source
10	set value reached	bit no. 10 = 1: Depending on the active mode it is indicated whether the present set value is reached.
11	reserved	reserved
12, 13	mode dependant	see table „total overview for all modes“
14, 15	state bits	see P134, P135

The unit state is represented by the following bit combinations in the state word:

	Bit in state word						
	State of the unit control	Bit no. 6 INHIBIT START	Bit no.5 * RAPID HALT	Bit no. 3 FAULT	Bit no. 2 OPERA- TION ENA- BLED	Bit no. 1 SWIT- CHED ON	Bit no. 0 READY TO START
0	NOT READY TO START	0	×	0	0	0	0
1	INHIBIT START	1	×	0	0	0	0
2	READY TO START	0	1	0	0	0	1
3	SWITCHED ON	0	1	0	0	1	1
4/5/6	OPERATION ENABLED	0	1	0	1	1	1
F	FAULT	0	×	1	0	0	0
E	FAULT REACTION ACTIVE	0	×	1	1	1	1
7	RAPID HALT ACTIVE	0	0	0	1	1	1

The bits designated with × have no effect on the unit control state.

 * low active

State word: total overview for all modes

Bit no.	Locating position -1	Current control -2	Speed control -3	Speed specification 1 2	Position control -4	Manual mode 5	Synchronisation control -5	Reference run mode 6	Target position specification 1	Spindle positioning -6
0	READY TO START (state machine)									
1	SWITCHED ON (state machine)									
2	ENABLE OPERATION (state machine)									
3	FAULT (state machine)									
4	VOLTAGE INHIBITED (state machine) *									
5	RAPID HALT (state machine) *									
6	INHIBIT START (state machine)									
7	×	×	×	×	×	×	×	×	×	×
8	×	×	×	×	×	×	×	×	×	×
9	remote									
10	set value reached									
	×	×	speed set value	speed set value	position set value	×	position set value	reference speed	position reached	in position
11	×	×	×	×	×	×	×	×	×	×
12	×	×	×	×	×	×	×	reference run finished	set value acknowledgement	×
13	×	×	×	×	×	×	×	reference run error	×	×
14	state bit see P134, M state bit 14									
15	state bit see P135, M state bit 15									

The bits designed with × are reserved and have to be set 0.

 * low active

Bit no. 10: „set value reached“ is actualised only in state OPERATION ENABLED.

P122 M desired operation mode

This parameter corresponds to DRIVECOM object 6060_{hex} and sets the mode for the drive.

Selection code	Mode	Comment
-6	Spindle positioning	standard, see additional description technology function positioning
-5	Synchronisation control	standard
-4	Position control	standard
-3	Speed control	standard
-2	Current control	standard
-1	Locating position reference point setting	standard
1	Target position specification	standard, see additional description technology function positioning
2	Speed specification 1	standard
5	Manual mode	standard, see additional description technology function positioning
6	Reference run mode	standard, see additional description technology function positioning

The operation modes can be changed with controller disabled (off-line), but partly with enabled controller (on-line). See table M actual mode (P123), too.

P123 M actual operation mode

This parameter corresponds to DRIVECOM object 6061_{hex} and indicates the currently active drive mode (see also set mode table). For switching from the current mode to the desired actual mode the following schematic diagram applies:

Mode switching

Mode switching	-5	-4	-3	-2	from -1	2	6	5	1	-6
to	Synchronisation control	Position control	Speed control	Current control	Locating position	Speed specification 1	Reference run mode	Man. mode	Target position spec.	Spindle positioning
Synchronisation control	X	2	2	2	1	2	2	2	2	2
Position control	2	X	2	2	1	2	2	2	2	2
Speed control	2	2	X	2	1	2	2	2	2	2
Current control	2	2	2	X	1	2	2	2	2	2
Locating position	1	1	1	2	X	1	1	1	1	1
Speed specif. 1	2	2	2	2	1	X	2	2	2	2
Reference run	2	2	2	2	1	2	X	2	2	2
Manual mode	2	2	2	2	1	2	2	X	2	2
Target position specification	2	2	2	2	1	2	2	2	X	2
Spindle positioning	2	2	2	2	1	2	2	2	2	X

When 1

mode switching is only possible off-line in the INHIBIT START, READY TO START and SWITCHED ON state types.

When 2

mode switching is possible off-line in the INHIBIT START, READY TO START and SWITCHED ON state type as well as on-line in the OPERATION ENABLED state.

P124 M error code

In case of a fault, the corresponding error code can be found here. This error is acknowledged if the bit „reset fault“ in the control word (P120) is set from 0 to 1 or the input „error reset“ is enabled (see P136 M mode).

If several errors are present, the next error is displayed immediately after acknowledgement. Error codes see chapter maintenance, error messages.

P125 M error index

This parameter indicates the number of errors which are present. On acknowledgement of each error the displayed value is decreased. The parameter contains the number 0 after acknowledging all errors.

P136 M mode

This parameter chooses the different options to acknowledge an error message (see connection of function inputs in chapter installation).

Bit no.	Meaning
0	0: errors are acknowledged individually with bit no. 7 0 → 1 1: errors are acknowledged in one go with bit no. 7 0 → 1
1	0: acknowledge errors only with control word P120 possible (e.g. with digital input 3 X26:18 DELETE ERROR) 1: acknowledge errors only with pulse enabling input X26:14 possible
2	0: pulse enabling and controller enabling are interpreted as single signals (pulse enabling X26:14, CONTROLLER ENABLING with digital input 4 X26:17) 1: pulse enabling and CONTROLLER ENABLING are interpreted as one combined signal (X26:14)
3 ... 15	reserved

P137 M state 1

Bit no.	Meaning
0 ... 3	Shows the state number displayed in the 7 segment display
4, 5	00: drive displays no error 01: error has occurred, error reaction is set in P189 11: fatal error has occurred, immediate pulse
6 ... 15	reserved

P126 M communication source

The access rights of the various sources of communication are managed via this parameter. Sources of communication are all program modules which exchange data with a master control via a communication protocol. As several of these program modules can be implemented in the drive, but not all modules can have simultaneous access to all parameters (particularly the drive manager's status word P120), write-access must be managed correspondingly.

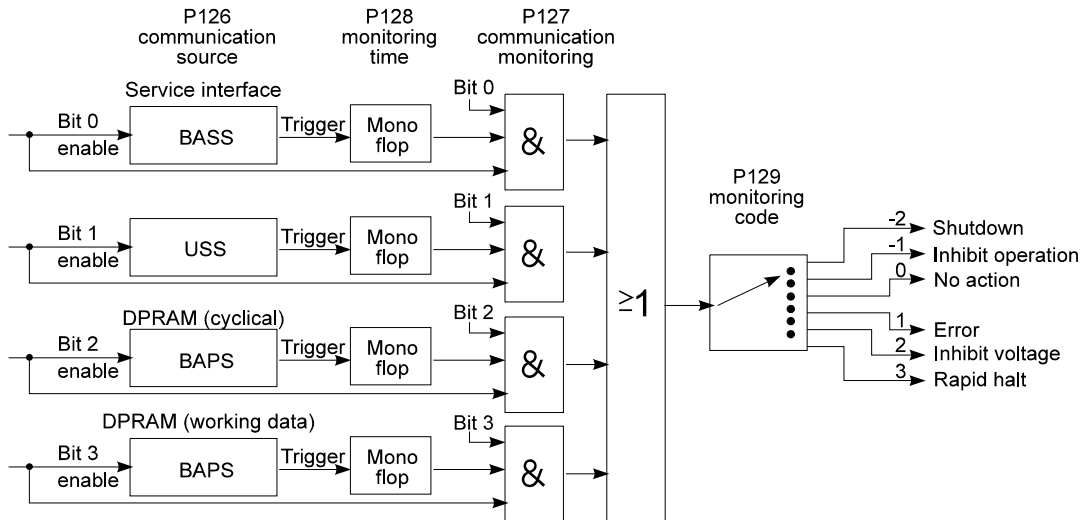

Depending on the parameter „communication source“ the drive manager activates and deactivates the various communication modules. Each communication module has a state parameter where the current state (RUN/STOP) is displayed.

A communication module is only allowed to write-access drive parameters when in the RUN status. In the STOP status no write-access is allowed. Reading the drive parameters is possible in any state.

The parameters M communication source (P126) and DSM command (P190) can be changed always with service interface and dual port RAM interface (BASS protocol, operation program).

According to the unit configuration, the following sources of communication are possible:

Bit no.	Meaning
0	1: BASS protocol via RS 232 enabled
1	1: USS protocol via RS 485 enabled
2	1: dual port RAM (cyclic data) enabled
3	1: dual port RAM (working data) enabled
4 ... 15	reserved

If the parameter „communication source“ is set to 0, the drive can only be controlled via pulse enabling (PE), rapid halt (RH) and CONTROLLER ENABLING. As no master control is available, the drive manager itself can set the corresponding control commands.

P127 M communication monitoring

Monitoring of the sources of communication can be activated via this parameter.

Bit no.	Meaning
0	1: BASS protocol via RS 232 is monitored
1	1: USS protocol via RS 485 is monitored
2	1: dual port RAM (cyclic data) is monitored
3	1: dual port RAM (working data) is monitored
4 ... 15	reserved

P128 M monitoring time

This parameter sets the time constant of communication monitoring. It is valid for all sources of communication.

If no information from the current communication source is received within the period set in the parameter „monitoring time“, e.g. as a result of an open circuit on an interface cable or defective communication card, the action selected in the parameter „monitoring selection code“ is carried out. Monitoring time can be up to one minute with the representation unit being 1 ms. If the time 0 ms is entered, monitoring is switched off.

If the controller is operated without communication (P126 = 0), monitoring time must be set to 0 ms.

P129 M monitoring code

This parameter corresponds to DRIVECOM object 6004_{hex} and determines the drive reaction in the event of the communication monitoring time being exceeded. It is not important which communication source caused the timeout.

Selection mode	Function
-2	command SHUTDOWN is updated
-1	command INHIBIT OPERATION is updated
0	no action
1	transition to fault state
2	command INHIBIT VOLTAGE is updated
3	command RAPID HALT is updated

P130 M HALT code

This parameter corresponds to DRIVECOM object 605D_{hex} and determines the drive reaction in the unit control state machine in the OPERATION_ENABLED status. The HALT function is only implemented in the speed control and speed specification 1 modes.

Depending on control bit no. 4 „inhibit RFG“ the HALT function selected by the HALT code is carried out.

Code	Function
0	inhibit drive function
1	shutdown procedure at ramp-down ramp of ramp function generator
2	shutdown procedure at RAPID HALT ramp (set at P009)
3	shutdown procedure at current limit

P131 M RAPID HALT code

This parameter corresponds to DRIVECOM object 605A_{hex} and determines the drive reaction in the unit control state machine in the RAPID HALT ACTIVE state.

Code	Function
0	inhibit drive function
1	shutdown procedure at ramp-down ramp of ramp function generator
2	shutdown procedure at RAPID HALT ramp (set at P009)
3	shutdown procedure at current limit

P132 M INHIBIT code

This parameter corresponds to DRIVECOM object 605C_{hex} and determines the drive reaction in the unit control state machine during transition 5.

Code	Function
0	inhibit drive function
1	shutdown procedure at ramp-down ramp of ramp function generator
2	shutdown procedure at RAPID HALT ramp (set at P009)
3	shutdown procedure at current limit

P133 M SHUTDOWN code

This parameter corresponds to DRIVECOM object 605B_{hex} and determines the drive reaction in the unit control state machine during transition 8.

Code	Function
0	inhibit drive function
1	shutdown procedure at ramp-down ramp of ramp function generator
2	shutdown procedure at RAPID HALT ramp (set at P009)
3	shutdown procedure at current limit

P134 M state bit no. 14

P135 M state bit no. 15

These parameters guide the bit no. 14 and 15 in state word (P120). From arbitrary 16 bit parameters a single bit can be copied to the state word.

Bit no.	Meaning
0... 10	1 .. 2047: no. of parameter, binary code 0 state bit is not updated
11	reserved
12 ... 15	0 ... 15: bit no., binary code

Examples:

1. The N=0 signal from encoder 1 (P025, bit no. 10) should be connected with state bit no. 14: P134 must be set to A019_{hex}.
2. Exceeding the dynamic deviation (P200, bit no. 4) should be connected with state bit no. 15: P135 must be set to 40C8_{hex}.

P188 M error reaction time

If an error occurs, the error reaction time is started. The set error reaction in P189 must be finished within this time, otherwise the drive will be inhibited immediately (inhibit pulses).

P189 M error reaction code

This parameter sets the drive's reaction to a defined error in state ERROR REACTION ACTIVE (see chapter maintenance, error messages).

If a fatal error occurs, the setting of P189 will be ignored and the drive function is inhibited immediately (inhibit pulses).

Code	Function
0	inhibit drive function
1	shutdown procedure at ramp-down ramp of ramp function generator
2	shutdown procedure at RAPID HALT ramp (set at P009)
3	shutdown procedure at current limit

7.20 Data Set Management

Function

Data sets can be loaded from EPROM, changed and saved. 4 data sets can be managed at every time.

- **After switching on (booting)**

Directly after switching on the operating voltage supply the DSM (data set management) automatically loads the boot data set (data set 0) into the drive's user memory.

After successful execution of this command the DSM stops in

state 0003: STAND_BY (P191)
message 0000: no error (P192).

If no boot data set has been created yet, the DSM is in

state 000B: STAND_BY with error (P191)
message 0002: data set not available (P192).

In addition to the drive managers state changes to „F“ fault and parameter M error code (P124) displays the error code 0902.

- **Creating and updating a boot data set**

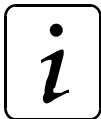

NOTE

Prior to any new action the DSM (data set management) must first be reset by the command 0: Reset (P190)

This measure sets all DSM parameters to value 0. This also refers to data set name (P193) and data set version (P194), which in this state represent the boot data set.

It must now be set via the command 5: write data set into EEPROM (P190) how the boot data set is to be created for the first time in EEPROM or how an existing boot data set is to be updated. ¹⁾

Only in the case of message 0000: no error (P192) and DSM state 0003: STAND_BY is the data set been written correctly.

¹⁾ The counter „DS program cycle“ (P197) is increased by 1.

- **Creating and updating other data sets**

The procedure is identical to that of creating and updating a boot data set except that the parameter data set name (P193) can now be selected from numbers 1 to 2.

Data sets can be transmitted to the working memory with command 6: read data set from EEPROM (P190).

Only in the case of DSM message 0000: no error (P192) and DSM state 0003: STAND_BY has the data set been written correctly.

- **Source load of the parameters**

If a source load is carried out the standard values of the parameter list are set and therefore a defined state is reached.

The procedure of the source load is mentioned below:

1. P190 = 0 command reset data set management
2. P190 = 7 command delete data set
3. Wait until P191 = 0003
4. Switch off power supply of controller
5. Switch on power supply of controller
6. Now is displayed: P191 = 000B stand-by with error
P192 = 0002 data set not available
P124 = 0902

The controller's state is fault

7. P190 = 0 command reset data set management
8. P190 = 5 command store data set
9. Wait until P191 = 000B

- **Store the write protected data set**

1. P190 = 0 command reset data set management
2. P190 = 8 command input password
3. P190 = password 1
4. P190 = 0 command reset data set management
5. P193 = 3 DS no. write-protected data set
6. P190 = 5 command store data set

- **Change article no. of data set**

1. P190 = 0 command reset data set management
2. P190 = 8 command input password
3. P190 = password 2
4. P190 = 0 command reset data set management
5. P193 = 0, 1, 2, (3)* data set no.
6. P194 = new article no. hexadecimal number
7. P190 = 5 command store data set

* only possible, if password 1 was already given

Overview of the commands

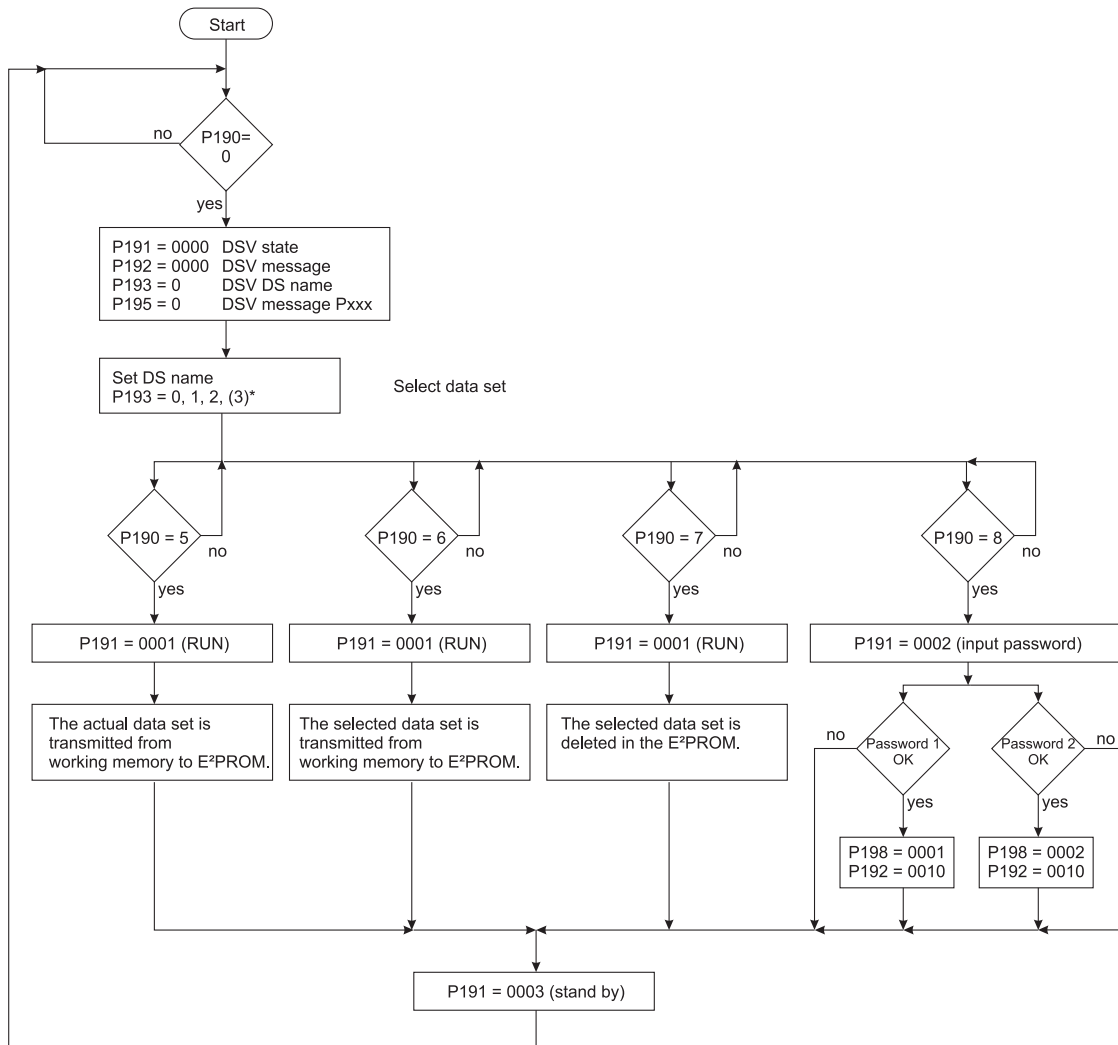

Parameter overview

Parameter	name	Range min. ... max.	Unit	Display only
P190	DSM command	0 ... 8	0	
P191	DSM state	0000 ... FFFF		×
P192	DSM message	0000 ... FFFF		×
P195	DSM message Pxxx	0 ... 700		×
P193	DSM DS name	0 ... 3		
P194	DSM DS article no.	0000 0000 ... FFFF FFFF		×
P197	DSM DS program cycles	0 ... 65536		×
P196	DSM load data set	0 ... 3		
P198	DSV key	0000 ... 0003		×

Parameter description

P190 DSM command

This command instructs the data set management to load, save or delete an existing data set.



NOTE

This parameter is independent of the parameter M communication source (P126) always changeable.

Command	Meaning
0	reset of data set management The parameter P191 till P195 are set automatically to 0.
5	save data set from user memory to EEPROM
6	load data set from EEPROM to user memory
7	delete EEPROM data set
8	input password

P191 DSM state

Bit no.	Meaning
0 ... 2	000 : STOP Data set management is ready for a command or for changing data sets. 001 : RUN Data set management is processing a command. 011 : STAND_BY Data set management has finished a command.
3	1 : An error has occurred in the data set management. Error code see P124, M error code and P192, DSM message
4 ... 15	reserved

P192 DSM message

If a message occurs during the implementation of a command, it is displayed in this parameter.

Bit no.	Meaning
0	1: undefined command
1	1: data set not available
2	1: wrong check sum
3	1: parameter not changeable
4	reserved
5	1: memory full
6	1: error in configuration list
7	1: undefined parameter format

P195 DSM message Pxxx

If a message has occurred (P192 ≠ 0), this parameter shows the parameter no. involved.

P193 DSM DS name

A maximum of 4 data sets can be managed in each memory area. They are selected via the parameter „data set name“.

Value	Memory range EEPROM (non-volatile)
0	data set 0 (boot data set)
1	data set 1
2	data set 2
3	data set 3 (write-protected data set)

P194 DSM DS article no.

Article no. of a data set ex factory.

P197 DSM DS program cycles

Number of write actions on this data set.

P196 DSM load data set

The data set with the corresponding number (0...2) can be loaded from the EEPROM into the working memory via this parameter.

The following procedure should be adhered to:

- Firstly, ensure that the status of the data set management (P191) is either set to 0 (STOP) or to 0003 (STAND_BY).
- Next enter the number of the required data set in the parameter, P196 (DSM load data set).
- All further steps follow independently:
 - The number of the required data set is displayed in parameter P193.
 - The command 6 „load data set from EEPROM into user memory“ is visible in the parameter P191 (DSM command).
 - The data set is loaded.
- The procedure is completed once the DSM status displays again state 0003 (STAND_BY).
(Incidentally entered numbers should be ignored.)

Change data set via P196

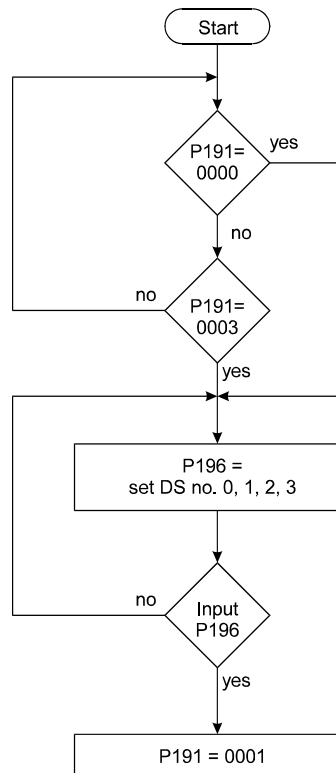

The time in which this procedure is carried out will differ according to the loading of the microprocessor.

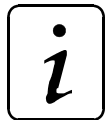

NOTE

This parameter can be used to change data sets via digital inputs. A change over must not be executed if controller is enabled!

P198 DSM key

Bit no.	Meaning
0	0: Data set 3 is write-protected 1: Data set 3 is write-enabled (only after input of password 1)
1	0: The article no. of all data sets is write-protected 1: The article no. of all data sets is write-enabled (only after input of password 2)
2 ... 15	reserved

7.21 Operation System

Parameter overview

Parameter	Name	Range min. ... max.	Unit	Display only
P138	Language	0 ... 4		
P166	OS state	0000 ... FFFF		
P162	OS message	0 ... 9999		×
P161	OS sampling time	124,8 ... 4000,0	μs	×
P167	OS sync. slot	0 ... 8000	μs	
P168	OS sync. offset	0 ... 8000	μs	
P159	OS sync. tolerance	0,2 ... 80,0	μs	
P174	OS user software	0 ... 99		×
P163	OS BUS6-VC SW release	0,00 ... 99,99		×
P160	OS selection	0 ... 1000		
P169	OS value	0 ... 65535		

Parameter description

P138 Language

Here you can set the language for parameter text.

Value	Language
1	German
2	English
3	reserved
4	reserved

P166 OS state

This parameter displays the state of the function module operation systems.

Bit no.	Meaning
0 ... 3	1: operation system runs
4	1: controller is synchronized to sync. signal
5	1: correction of synchronisation active within longer controller sampling time
6	1: correction of synchronisation active within shorter controller sampling time
7	sync. signal is available
8 ... 11	reserved
12	1: main program cycle time exceeds maximum value
13	1: task calculation time has exceeded maximum value
14	1: sync. IR calculation time has exceeded maximum value
15	reserved

P162 OS message

This parameter shows the number of operation system errors.

P161 OS sampling time

The system clock shows the run interval of the shortest operation system time slot.

P167 OS sync. slot

Value	Meaning
0	operation system synchronisation is not active
500 μ s	controller synchronisation in 0.5 ms clock time*
1000 μ s	controller synchronisation in 1 ms clock time*
2000 μ s	controller synchronisation in 2 ms clock time*
4000 μ s	controller synchronisation in 4 ms clock time*
8000 μ s	controller synchronisation in 8 ms clock time*

* The zero pulse evaluation via encoder input 2 is not possible.

P168 OS sync. offset

The synchronisation time point can be moved within the chosen synchronization clock.

P159 OS sync. tolerance

Within the set tolerance range the sync. signal is allowed to differ from nominal value for a short time.

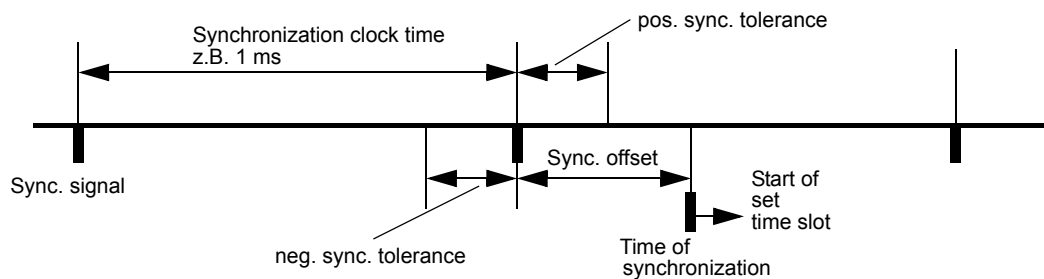

P174 OS user SW

Value	Meaning
0	production run software
>0	user fitted software

P163 OS BUS6-VC SW release

This parameter displays the software release of the controller.

Parameters

P160 OS selection

P169 OS value

With this parameter different measured values can be read from operation system.

Selection P160	Value P169	Unit
4	Maximum value of main program cycle time (The maximum value memory can be reset through writing on)	[1 ms]
40	Actual measured values of main program cycle time	[1 ms]
41	Maximum value of main program cycle time (from SW 14.09)	[250 µs]
42	Actual measured value of main program cycle time (from SW 14.09)	[250 µs]
5	16 bit counter for main program cycles	[1]

7.22 Ramp Function Generator

Function:

The ramp function generator (RFG) manages the 4 set value inputs, which can alternatively be switched to the output. The ramp-up and ramp-down times can be set separately for each input.

(If set to STOP by means of P013, only the ramp-down time can be adjusted)

All inputs and the output of the ramp function generator are relative parameters ($\pm 100\%$) and standardized to maximum speed (P019).

The ramp steepness for the acceleration and braking procedures are determined by the ramp-up and ramp-down times. The times thus refer to 100% set value alteration.

With exception of the fourth set speed value, which is programmed to zero, every input can take speed values between -100% and $+100\%$. 100% corresponds with maximum speed (P019).

The ramp function generator is only active in mode speed control (P122 = -3) and speed precontrol 1 (P122 = 1), as well at the different braking procedures initiated by the drive manager (transitions 5, 8 and 11).

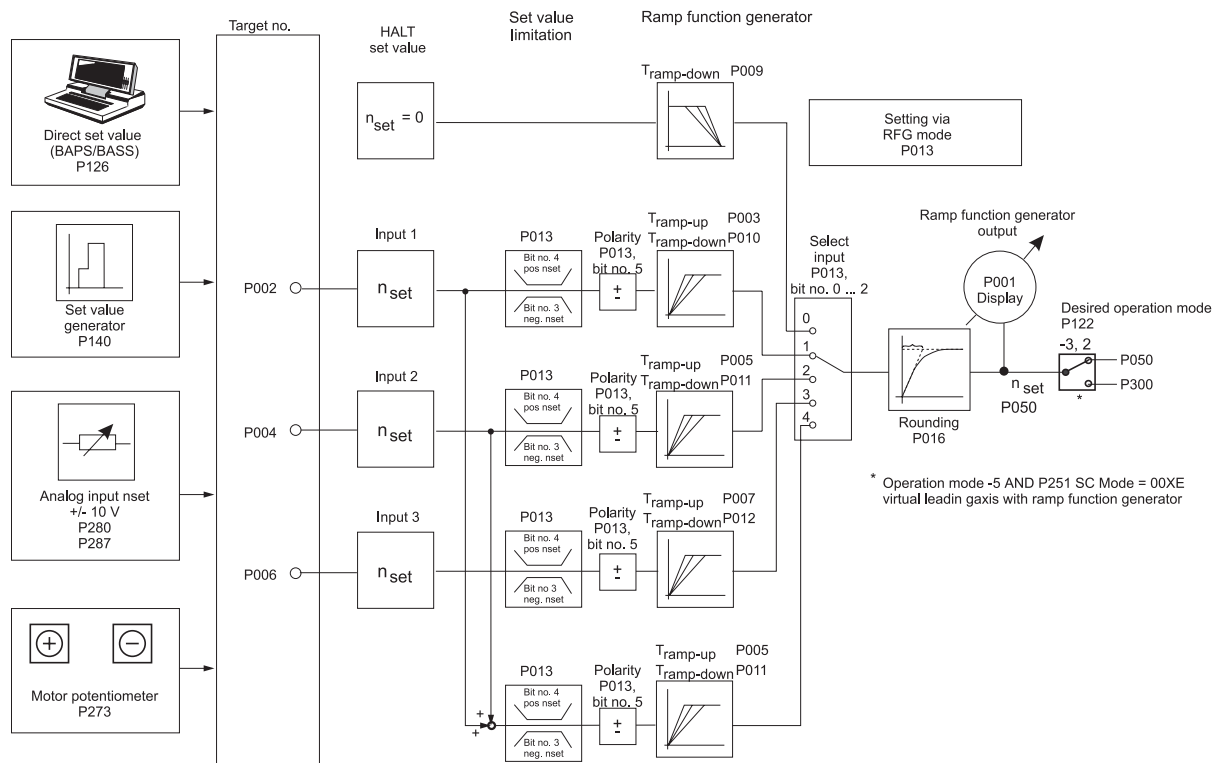

Parameters

Parameter overview:

Parameter	Name	Range min. ... max.	Unit	Display only
P014	RFG state	0000 ... FFFF		×
P013	RFG mode	0000 ... 007F		
P002	RFG input 1	-100,00 ... 100,00	%	
P004	RFG input 2	-100,00 ... 100,00	%	
P006	RFG input 3	-100,00 ... 100,00	%	
P003	RFG ramp-up time 1	0,00 ... 650,00	s	
P010	RFG ramp-down time 1	0,00 ... 650,00	s	
P005	RFG ramp-up time 2	0,00 ... 650,00	s	
P011	RFG ramp-down time 2	0,00 ... 650,00	s	
P007	RFG ramp-up time 3	0,00 ... 650,00	s	
P012	RFG ramp-down time 3	0,00 ... 650,00	s	
P009	RFG time halt	0.000 ... 60,000	s	
P016	RFG rounding	0 ... 60000	ms	
P001	RFG output	-100,00 ... 100,00	%	×

Parameter description

P014 RFG state

Displays the function module's state.

Bit no.	Meaning
0 ... 2	000: STOP 001: RUN
3	1: error in function module, error code see M error code (P124)
4	1: RFG output is set internally to 0 (RFG_LOCKED)
5	1: RFG was stopped on the ramp (RFG_STOP)
6	1: RFG input is set internally to set value 0 (RFG_ZERO)
7	1: rapid-halt ramp is active (RFG_RHALT)
8	1: ramp-up procedure is active
9	1: ramp-down procedure is active
10 ... 11	reserved
12	1: RFG output = RFG input (set value reached)
13 ... 15	reserved

P013 RFG mode

The input selection chooses one out of four inputs of the ramp function generator and activates the set value limitation.

Bit no.	Meaning
0 ... 2	000: halt *) 001: input 1 010: input 2 011: input 3 100: sum of input 1 and input 2
3	1: negative set values are disabled
4	1: positive set values are disabled
5	1: change polarity of actual set value
6	1: halt is activated, the motor brakes to speed 0 with set ramp. The controller is active after n = 0. **)
7	from SW 09.10 0: P009 HLG time halt is related to 100 % set value changing 1: P009 HLG time halt is related to the actual set value ⇒ N=0 ***)
8 ... 15	reserved

*) P016 RFG rounding active while halt ramp. P047 N additional set value active furthermore.

**) P016 RFG rounding active while halt ramp. P047 N additional set value is set to 0 %.

***) from SW 14.10

Restriction when bit 7 = 1:

With very small set speed and long halt time a value < 1 is calculated for the internal speed change.

For the deceleration the internal minimum value of 1 is used then.

$$\text{Limit: } \frac{\text{halt time [s]}}{\text{actual set value}} \leq 5368$$

P002 RFG input 1**P004 RFG input 2****P006 RFG input 3**

All 3 inputs are balanced and can be written via the serial interface, position controller and the set value generator as well as the analog set value input.

P003 RFG ramp-up time 1**P005 RFG ramp-up time 2****P007 RFG ramp-up time 3**

The acceleration assigned to the inputs can be set via the ramp-up times. The time selected here correspond to a set value alteration of 100 %.

Parameters

PO10 RFG **ramp-down time 1**

PO11 RFG **ramp-down time 2**

PO12 RFG **ramp-down time 3**

PO09 RFG **time halt**

The deceleration assigned to the inputs can be set via the ramp-down times. The time selected here correspond to a set value alteration of 100 %.

PO16 RFG **rounding**

A first-order time delay element is implemented in order to round off ramp corners. The time constants of the PT_1 device can be set by this parameter.

PO01 RFG **output**

This parameter displays the actual output value.

7.23 Set Value Generator



NOTE

Only parameters of 2 byte length are used in this module.

Function

The module creates a plateau set value for each of the 4 time zones. Both the plateau amplitude and the output time interval per zone can be allocated parameters. The amplitudes are relative and are standardised by means of the min./max. receiver values. On termination of the last time zone the first time zone starts again. Each time the controller is enabled the set value generator is newly started in zone 1. When leaving the state „operation enabled“ (P121), the set value generator is stopped.

Thus e.g. the following speed set value graph can be created:

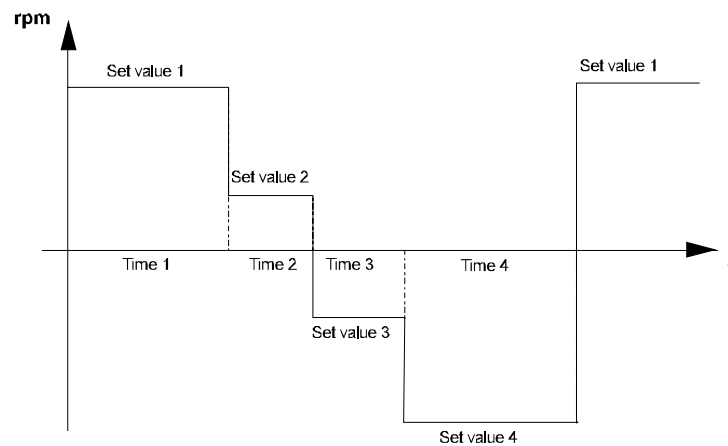

Parameter overview

Parameter	Name	Range min. ... max.	Unit	Display only
P150	SVG state	0000 ... FFFF		×
P140	SVG target Pxxx	0 ... 700		
P141	SVG output	- 100,00 ... + 100,00	%	×
P142	SVG set value 1	- 100,00 ... + 100,00	%	
P143	SVG set value 2	- 100,00 ... + 100,00	%	
P144	SVG set value 3	- 100,00 ... + 100,00	%	
P145	SVG set value 4	- 100,00 ... + 100,00	%	
P146	SVG time 1	0,001 ... 60,000	s	
P147	SVG time 2	0,001 ... 60,000	s	
P148	SVG time 3	0,001 ... 60,000	s	
P149	SVG time 4	0,001 ... 60,000	s	

Parameter description

P150 SVG **state**

This parameter displays the internal function module state.

Bit no.	Meaning
0 ... 2	000: STOP 001: RUN
3 ... 15	reserved

P140 SVG **target Pxxx**

To this parameter no. the output value is written (e.g. parameter P002, input 1 ramp function generator).

P141 SVG **output value**

The actual set value is displayed here.

P142 SVG **set value 1**

P143 SVG **set value 2**

P144 SVG **set value 3**

P145 SVG **set value 4**

Parameter values between -100 % and +100 % can be assigned to these 4-amplitude-parameters. The amplitudes are connected to the output value according to the time assigned to them.

P146 SVG **time 1**

P147 SVG **time 2**

P148 SVG **time 3**

P149 SVG **time 4**

Values between 8 ms and 60 s can be assigned to these time parameters. The corresponding amplitudes are switched to the output value during these time intervals.

7.24 Motor Potentiometer

Function

The motor potentiometer allows the alteration of all signed parameter values with data length 2 bytes. Therefore it is necessary to program two digital inputs on the parameter EA motor potentiometer + (P271) and EA motor potentiometer - (P272). The cycle time of the function module is 32 ms.

Parameter overview

Parameter	Name	Range min. ... max.	Unit	Display only
P270	EA mode	0 ... 2		
P271	EA motor potentiometer +	0 ... 1		
P272	EA motor potentiometer -	0 ... 1		
P273	EA motor potentiometer Pxxx	0 ... 700		
P274	EA motor potentiometer dynamics	0 ... 2		
P275	EA motor potentiometer increment	0,01 ... 20,00	%	
P276	EA motor potentiometer value	- 199,99 ... + 199,99	%	×
P567	EA state	0000 ... FFFF		×
P568	EA ramp-up final value	- 100,00 ... + 100,00	%	
P569	EA ramp-down final value	- 100,00 ... + 100,00	%	

Parameter description

P270 EA mode

Value	Meaning
0	no function
1	motor potentiometer function active motor potentiometer value is synchronized on value of motor potentiometer Pxxx
2	motor potentiometer function active motor potentiometer value and motor potentiometer Pxxx are set to 0 when switched on

P271 EA motor potentiometer +

Value	Meaning
0	inching + off
1	inching + on („motor potentiometer output value“ is increased)

P272 EA motor potentiometer -

Value	Meaning
0	inching - off
1	inching - on („motor potentiometer output value“ is decreased)

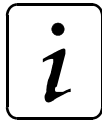

NOTE

The motor potentiometer output value is not changed, if EA motor potentiometer + and EA motor potentiometer - equal 1.
No target parameter number check is carried out.

P273 EA motor potentiometer Pxxx

The inching function target Pxxx serves to specify the receiver address (= target parameter) of the output value, e.g. input ramp function generator.

P274 EA motor potentiometer dynamics

The setting dynamics for key operation can be set here.

Value	Meaning
0	Step-by-step increment, on every LO/HI transition the output value is changed by the value „increment“ with the correct polarity
1	Linear increment, during the HI signal the output value is changed by the value „increment“ at every cycle
2	Square-law increment, during the HI signal the output value is changed with the right polarity at every cycle with square-law „increment“

P275 EA motor potentiometer increment

The value by which the output value is altered on key operation can be set via this parameter.

The motor potentiometer increment is internal standardized the following way:

$$\text{increment}_{\text{int}} = \frac{\text{increment(P275)[\%]}}{100\%} \cdot \text{MAX}_{\text{value}}$$

$\text{MAX}_{\text{value}}$ = maximum amount of the range limits of the target parameter
For $\text{MAX}_{\text{value}}$ the internal standardization is used.
(see Parameter List on page 241.)

e.g. increment = 0,4 % (P275)
motor potentiometer Pxxx = 6 (P273) $\text{MAX}_{\text{value}} = 16383$

$$\text{increment}_{\text{int}} = \frac{0,4}{100} \cdot 16383 = 66 \text{ (round)}$$

$$\text{that means effective increment} = \frac{66 \cdot 100\%}{16383} \approx 0,403\%$$

P276 EA motor potentiometer value

This parameter describes the inching function module output.

P567 EA state

Displays the internal state of the function module.

Bit-Nr.	Bedeutung
0 ... 2	000: STOP (motor potentiometer switched off) 001: RUN (motor potentiometer switched on)
3	reserved
4	1: ramp-up final value reached with inching +
5	1: ramp-down final value reached with inching -
6	1: key inching + pressed
7	1: key inching - pressed
8	1: inching + active (ramp-up)*
9	1: inching - active (ramp-down)*
10	1: limit of the target parameter reached
11 ... 15	reserved

*: Bit 8 and 9 are deleted as soon as the limiters are reached.

**NOTE**

From SW 14.07.

P568 EA ramp-up final value

This maximum value is not exceeded by the motor potentiometer even the "inching +" key is pressed.

The value must be higher than the lower limit set in P569 EA ramp-down final value. If this condition is not fulfilled the input value is rejected.

**NOTE**

From SW 14.07.

If this final value is changed and the current output value (P267) is then outside the limiters, the drive moves towards the limited direction and the output value is set to the new final value when the inching key is pressed the first time.

P569 EA ramp-down final value

Even the "inching -" key is pressed, this value is the minimum value that can be reached.

The value must be lower than the upper limit set in P568 EA ramp-up final value. If this condition is not fulfilled the input value is rejected.



NOTE

From SW 14.07.

If this final value is changed and the current output value (P267) is then outside the limiters, the drive moves towards the limited direction and the output value is set to the new final value when the inching key is pressed the first time.

7.25 Analog Inputs

Function

The function module in combination with the 2 analog inputs enable the programming of 2 byte length parameters. **Cycle time of analog inputs: 1 ms**

Six parameters are assigned to each input:

- *AI input channel:* input channel entry
- *AI smoothing:* smoothing time constant [ms].
- *AI scaling:* scaling factor entry
- *AI offset:* offset entry
- *AI threshold value:* sensitivity of inputs
- *AI target Pxxx:* target parameter number entry
- *AI value:* current output value



NOTE

The sequence of the parameter setting is irrelevant. Switching is carried out as soon as the target parameter number has been set.

The target parameter number must be reset to zero in order to deactivate an input. However, the target parameter still contains the last output value. If AI target Pxxx is deactivated or newly set, the parameter „AI x offset“ is additionally set to zero.

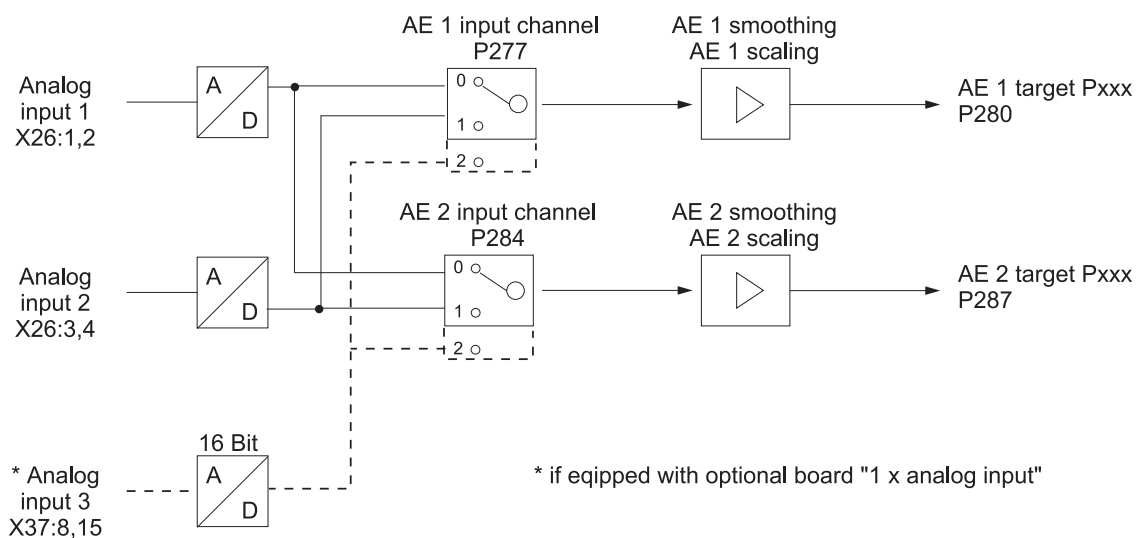

Parameter overview

Parameter	Name	Range min. ... max.	Unit	Display only
P302	AI state	0000 ... FFFF		×
P277	AI 1 input channel	0 ... 1		
P278	AI 1 smoothing	1 ... 30 from SW 14.10 0 ... 30	ms	
P279	AI 1 scaling	-2,00 ... 2,00		
P280	AI 1 target Pxxx	0 ... 700		
P281	AI 1 offset	-100,00 ... +100,00	%	
P282	AI 1 threshold value	0,00 ... 100,00	%	
P283	AI 1 value	-100,00 ... +100,00	%	×
P284	AI 2 input channel	0 ... 1		
P285	AI 2 smoothing	1 ... 30 from SW 14.10 0 ... 30	ms	
P286	AI 2 scaling	-2,00 ... 2,00		
P287	AI 2 target Pxxx	0 ... 700		
P288	AI 2 offset	-100,00 ... +100,00	%	
P289	AI 2 threshold value	0,00 ... 100,00	%	
P290	AI 2 value	-100,00 ... +100,00	%	×

Parameter description

P302 AI state

This parameter indicates the status of the analog inputs module.

Bit No.	Meaning
0	0: Evaluation of analog input 1 disabled 1: Evaluation of analog input 1 enabled
1	0: Evaluation of analog input 2 disabled 1: Evaluation of analog input 2 enabled
2 ... 7	Reserve
8 ... 15	Identifier of the option board 00: No option board connected 04: Option board with analog input channel with 16 bit resolution (adjustable via analog input x input channel = 2) All other values: reserved

P277 AI 1 input channel

P284 AI 2 input channel

Entry of the analog input for respective channel.

The two hardware implemented analog inputs 1 and 2 can be connected with each input channels. It is further possible to connect an analog input with different input channels.



NOTE

AI x input channel = 2 must be set only, if an option board with identifier 04 is present.

P278 AI 1 smoothing

P285 AI 2 smoothing

In order to smooth interference on the analog input signal a smoothing time constant can be entered in ms. Smoothing is switched off if the respective parameter is set to its minimum value.

P279 AI 1 scaling

P286 AI 2 scaling

These parameters enable scaling of the analog input variable.

The output values (see parameters P283, P290, P297, P304) of unsigned parameters are 0 till +100% and of signed parameters are -100 till +100%. Which analog input voltage this maximum values achieved depends on the scaling factor.

P280 AI 1 target Pxxx

P287 AI 2 target Pxxx

The receiver address for the output value can be set via this parameter.



NOTE

No target parameter number check is carried out.

P281 AI 1 offset

P288 AI 2 offset

These parameters can compensate for a possibly existing input voltage offset.

Parameters

P282 AI 1 threshold value

P289 AI 2 threshold value

The sensitivity of the inputs can be set via the threshold values.

P283 AI 1 value

P290 AI 2 value

The AI value displays the respective current output value taking scaling and offset compensation into consideration.

Basics of equation:

Maximum target parameter value:

MAX_value

Analog input voltage:

$U_{in} \{ -10 \dots +10 \text{ V} \};$

$U_{inmax} = +10\text{V};$

Equation:

- Unsigned parameters:

$$AI_value[\%] = \frac{U_{in}[V] + 10V}{2 \cdot U_{inmax}[V]} * Scaling * 100 \% + Offset$$

if $AI_value > 100 \%$ → $AI_value = 100 \%$

- Signed parameters:

$$AI_value[\%] = \frac{U_{in}[V]}{U_{inmax}[V]} * Scaling * 100 \% + Offset$$

if $AI_value > 100 \%$ → $AI_value = 100 \%$

if $AI_value < -100 \%$ → $AI_value = -100 \%$

Both for signed and unsigned parameters

$|AI_value[\%]| < \text{threshold value}[\%]$ then $AI_value = 0 \%$

Written to the target parameter:

$$\text{Value target} = \frac{AI_value[\%]}{100\%} \cdot \overline{MAXvalue}$$

Examples:

Input voltage ↔ AI-value [%] * MAX_value
→ target parameter value

scaling = 1; offset = 0%; threshold value = 0%;

Unsigned target parameter:

10 V ↔ 100 % * MAX_value
5 V ↔ 75 % * MAX_value
0 V ↔ 50 % * MAX_value
- 5 V ↔ 25 % * MAX_value
- 10 V ↔ 0 % * MAX_value

Signed target parameter:

10 V ↔ 100 % * MAX_value
5 V ↔ 50 % * MAX_value
0 V ↔ 0 % * MAX_value
- 5 V ↔ -50 % * MAX_value
- 10 V ↔ -100 % * MAX_value

scaling = 2; offset = -100%; threshold value = 0%;

Unsigned target parameter:

10 V (100 % * MAX_value
5 V (50 % * MAX_value
0 V (0 % * MAX_value
- 5 V (0 % * MAX_value (limitation !)
- 10 V (0 % * MAX_value (limitation !)

Signed target parameter:

10 V (100 % * MAX_value
5 V (0 % * MAX_value
0 V (-100 % * MAX_value
- 5 V (-100 % * MAX_value (limitation !)
- 10 V (-100 % * MAX_value (limitation !)

scaling = 1; offset = 0; threshold value = 10.1%;

Unsigned target parameter:

10 V (100 % * MAX_value
5 V (75 % * MAX_value
0 V (50 % * MAX_value
-5 V (25 % * MAX_value
- 9 V (0 % * MAX_value (threshold !)
- 10 V (0 % * MAX_value

Signed target parameter:

10 V (100 % * MAX_value
5 V (50 % * MAX_value
1 V (0 % * MAX_value (threshold !)
- 1 V (0 % * MAX_value (threshold !)
- 5 V (-50 % * MAX_value
- 10 V (-100 % * MAX_value

Examples of characteristic curves:

Unsigned target parameter

Offset = 0 %; scaling = 1

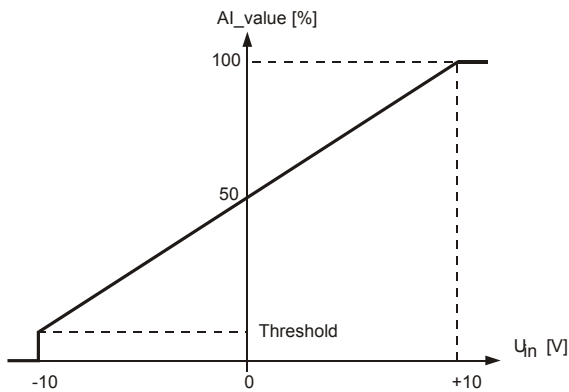

Signed target parameter

Offset = 0 %; scaling = 1

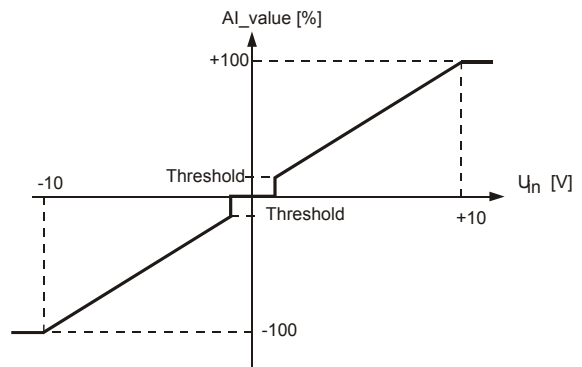

7.26 Analog Outputs

Function

The module „analog outputs“ transmits freely selectable (and scalable) parameter values to an analog output via a 12-bit digital-to-analog converter. It is possible transmitting 32-bit parameter either the low word to one channel or to channel 1 the low word and to channel 2 the high word of the 32 bit parameter. At a voltage range of ± 10 V the output current should not exceed 1 mA.



NOTE

The following sequence must be observed for writing the parameters:

1. AA x source-Pxxx
2. AA x offset
3. AA x scaling

Parameter overview

Parameter	Name	Range		Unit	Display only
		min.	... max.		
P338	AO state	0	... FFFF	-	×
P337	AO test value	-10,000	... +10,000	V	
P330	AO 1 source Pxxx	0	... 700		
P331	AO 1 offset	-100000	... +100000	Dig	
P332	AO 1 scaling	-25000	... +25000	Dig/V	
P334	AO 2 source Pxxx	0	... 700		
P335	AO 2 offset	-100000	... +100000	Dig	
P336	AO 2 scaling	-25000	... +25000	Dig/V	

Parameter description**P338 AO state**

Display of internal function module state.

Bit no.	Meaning
0	0: STOP, analog output 1 switched off 1: RUN, analog output 1 is active
1 ... 3	reserved
4	analog output 1 at negative threshold (-10V) (X26:7)
5	analog output 1 at positive threshold (+10V) (X26:7)
8	0: STOP, analog output 2 switched off 1: RUN, analog output 2 is active
9...11	reserved
12	analog output 2 at negative threshold (-10V) (X26:8)
13	analog output 2 at positive threshold (+10V) (X26:8)
14 ... 15	reserved

P337 AO test value

The analog output (DA converter) can be tested via this parameter.

e.g. AO 1 source Pxxx P330 = 337
 AO test value P337 = +10 → analog output 1 = + 10 V
 AO 1 scaling P332 = -2000 → analog output 1 = - 5 V
 AO offset channel 1 P331 = 14000 → analog output 1 = + 2 V

P330 AO 1 source Pxxx**P334 AO 2 source Pxxx**

The output parameter numbers are entered here.

The respective channel is switched off, if this parameter is equal 0.

If a 32 bit parameter is programmed on one channel, the low word of this parameter is transmitted. To transmit the high word, both channels (P330 and P334) must be programmed to the same parameter. As a result channel 1 transmits the low word and channel 2 the high word of the 32 bit parameter. Is channel 1 programmed to another parameter then channel 2 transmits the low word. That means that the high word of a parameter can't be transmitted separately without the low word. Channel 1 transmits always the low word and channel 2 transmits always the high word.

P331 AO 1 offset**P335 AO 2 offset**

The offset of the analog outputs is set here.

P332 AO 1 scaling**P336 AO 2 scaling**

A scaling factor can also be selected for optimum parameter output. The respective channel is switched off, if this parameter is equal 0.

7.27 LED Display

Function

The module enables programming of the four available freely programmable LEDs of the LED display H22.

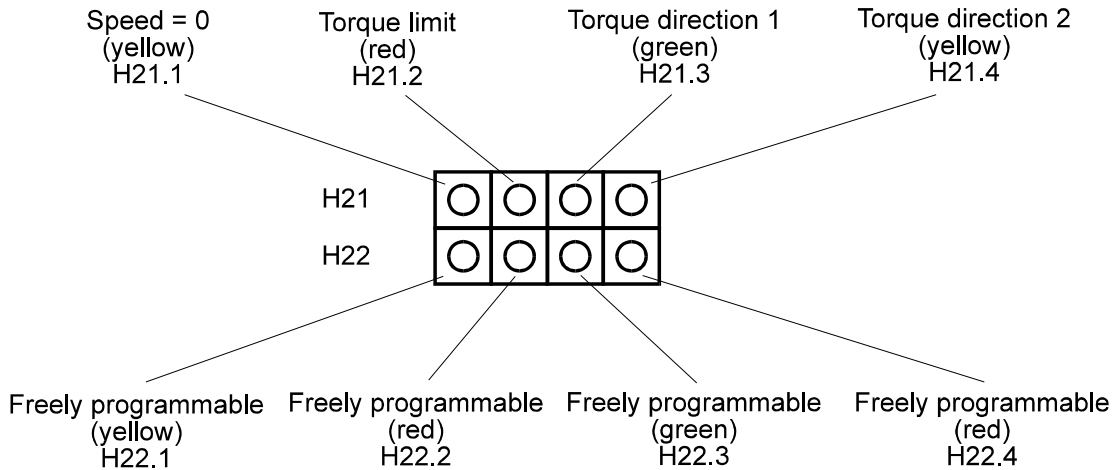

- *LED x source Pxxx:* Input of source parameter number.
- *LED x bit selection:* Selection of source parameter bits to which bit pattern must correspond.
- *LED x bit pattern:* If this bit pattern and the selected parameter bit pattern correspond to each other, the output is switched to high.

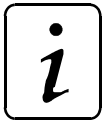

NOTE

The following sequence must be observed for writing the parameters:

1. LED x source-Pxxx
2. LED x bit selection
3. LED x bit pattern

Note:

The sequence of the parameter setting is irrelevant. Switching takes place only after all three parameters have been set.

In order to deactivate an LED output, either the LED source Pxxx or the LED bit selection must be set to zero. The last switch state, however, remains stored in the output. The output can be programmed again by setting the relevant parameter again.

Example of programming procedure:

1. Enter source parameter number in *LED x source Pxxx* of your choice.
→ Has no effect on the LED output yet.
2. Enter *LED x bit pattern* of the above mentioned parameter.
→ Has no effect on the LED output yet.
3. Enter *bit selection*:
→ All bits which have not been selected are set to 0 in the LED bit pattern, the bits selected from the source parameter are compared to the LED bit pattern.
If one of the two patterns corresponds to the source parameter pattern, the output is set to HIGH.

Example:

1. First set *LED 1 source Pxxx* to 13,
LED 1 bit pattern to 0001,
and *LED 1 bit selection* to 0003.
→ if bit no. 1 and bit no. 2 of parameter 13 result in „1“, the LED 1 is switched to high.
2. Then set *LED 2 source Pxxx* to 13,
LED 2 bit pattern to 0003,
and *LED 2 bit selection* to 0003.
→ If bit no. 1 and bit no. 2 of parameter 13 result in „3“, the LED 2 is switched on.

Parameter overview

Parameter	Name	Range min. ... max.	Unit	Display only
P362	LED state	0000 ... FFFF		×
P350	LED 1 source Pxxx	0 ... 700		
P351	LED 1 bit selection	0000 ... FFFF		
P352	LED 1 bit pattern	0000 ... FFFF		
P353	LED 2 source Pxxx	0 ... 700		
P354	LED 2 bit selection	0000 ... FFFF		
P355	LED 2 bit pattern	0000 ... FFFF		
P356	LED 3 source Pxxx	0 ... 700		
P357	LED 3 bit selection	0000 ... FFFF		
P358	LED 3 bit pattern	0000 ... FFFF		
P359	LED 4 source Pxxx	0 ... 700		
P360	LED 4 bit selection	0000 ... FFFF		
P361	LED 4 bit pattern	0000 ... FFFF		

Parameters

Parameter description

P362 LED state

This parameter display the state of the function module. .

Bit no.	Meaning
0	1: LED 1 completely programmed
1	1: LED 2 completely programmed
2	1: LED 3 completely programmed
3	1: LED 4 completely programmed
4 ... 7	reserved
8	actual state of LED H22.1
9	actual state of LED H22.2
10	actual state of LED H22.3
11	actual state of LED H22.4
12 ... 15	reserved

P350 LED 1 source Pxxx

P353 LED 2 source Pxxx

P356 LED 3 source Pxxx

P359 LED 4 source Pxxx

The parameter number of the source parameter for LED display is entered.

P351 LED 1 bit selection

P354 LED 2 bit selection

P357 LED 3 bit selection

P360 LED 4 bit selection

The bits to be compared are selected in the source parameter.

P352 LED 1 bit pattern

P355 LED 2 bit pattern

P358 LED 3 bit pattern

P361 LED 4 bit pattern

Bit pattern which is compared to the source parameter pit pattern.

7.28 Digital Inputs

The module and the four available digital inputs enable 16 bit parameter programming.

Four parameters are assigned to each input:

- *DI x target Pxxx*: Input of target parameter number
- *DI x bit selection*: Selection of the target parameter bits which are to be altered.
- *DI x LOW pattern*: Bit pattern which is written into the target parameter if switch is OFF.
- *DI x HIGH pattern*: Bit pattern which is written into the target parameter if switch is ON.

The inputs only evaluate the transitions

Hence it is possible to manipulate the same parameter via several inputs.

Example: Two inputs act on the same parameter bit

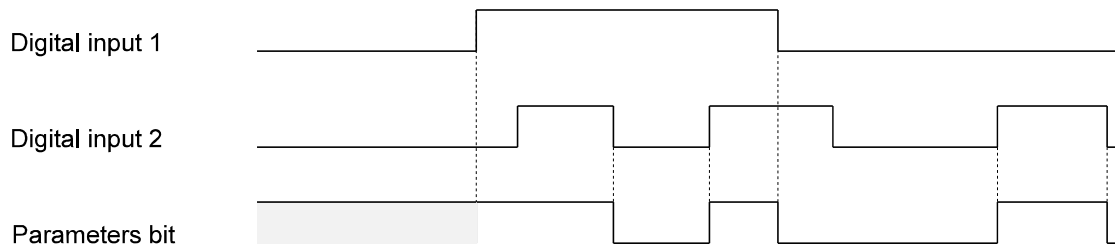

The 4 inputs are sampled every 4 ms at an interval of approx. 20 μ s. In the event of simultaneous status change of two signals the signal with the higher priority is taken over (digital input 1 has the lowest priority, digital input 4 the highest).

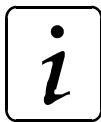

NOTE

The activation of a digital input results in setting all parameters of the selected input.

Following order must be observed:

1. DO x target Pxxx
2. DO x bit selection
3. DO x LOW pattern
4. DO x HIGH pattern

In order to deactivate an input the DI target Pxxx must be set to 0.

Example of programming procedure:

1. Enter target parameter number in *DI x target Pxxx* of desired input.
⇒ Has no effect on the target parameter yet.
2. Enter *DI x bit selection*:
⇒ all bits which have not been selected are set to 0 in the LOW and HIGH patterns; the selected bits are set to 0 in the target parameter and are replaced by the corresponding bit pattern (according to switch position).

Parameters

3. Enter *DI x LOW-* and *HIGH pattern* of the above mentioned input.

⇒ Has no effect on the target parameter yet.

Examples:

1. Input 1 should set parameter P013 to 0 (switch is LOW) and to 1 (switch is HIGH).

Set

DI 1 target Pxxx (P370) to 13,
DI 1 bit selection (P371) to FFFF
DI 1 LOW pattern (P372) to 0000,
DI 1 HIGH pattern (P373) to 0001,

2. Through programming of a further input the values 2 and 3 should adjusted in parameter P013. Following sequence is necessary:

Set

DI 1 target Pxxx (P370) to 13,
DI 1 bit selection (P371) to FFFD
DI 1 LOW pattern (P372) to 0000,
DI 1 HIGH pattern (P373) to 0001,
DI 2 target Pxxx (P374) to 13,
DI 2 bit selection (P375) to FFFE,
DI 2 LOW pattern (P376) to 0000,
DI 2 HIGH pattern (P377) to 0002.

→ The digital input 1 effects bit no. 0 and. 2 till 15; the digital input 2 effects bit no. 1 till 15.

Bit no.	15	14	13	12	11	10	9	8	7	6	5	4	3	2	1	0
Example for start value P013	1	1	1	1	0	0	0	0	1	1	1	1	0	1	0	1
input 1 → HIGH	0	0	0	0	0	0	0	0	0	0	0	0	0	0	0	1
input 2 → HIGH	0	0	0	0	0	0	0	0	0	0	0	0	0	0	1	1
input 1 → LOW	0	0	0	0	0	0	0	0	0	0	0	0	0	0	1	0
input 2 → LOW	0	0	0	0	0	0	0	0	0	0	0	0	0	0	0	0

3. The digital input 3 should effect bit no. 4 and 11 of parameter P120.

Set

DI 3 target Pxxx (P378) to 120,
DI 3 bit selection (P379) to 0810,
DI 3 LOW pattern (P380) to 0800,
DI 3 HIGH pattern (P381) to 0010,

Bit no.	15	14	13	12	11	10	9	8	7	6	5	4	3	2	1	0
Start value P120	0	0	0	0	0	0	0	0	0	0	0	0	1	1	1	1
input 2 → HIGH	0	0	0	0	0	0	0	0	0	0	0	1	1	1	1	1
input 2 → LOW	0	0	0	0	1	0	0	0	0	0	0	0	1	1	1	1

Parameter overview

parameter	Name	Range min. ... max.	Unit	Display only
P382	DI state	0000 ... FFFF		×
P370	DI 1 target Pxxx	0 ... 700		
P371	DI 1 bit selection	0000 ... FFFF		
P372	DI 1 LOW pattern	0000 ... FFFF		
P373	DI 1 HIGH pattern	0000 ... FFFF		
P374	DI 2 target Pxxx	0 ... 700		
P375	DI 2 bit selection	0000 ... FFFF		
P376	DI 2 LOW pattern	0000 ... FFFF		
P377	DI 2 HIGH pattern	0000 ... FFFF		
P378	DI 3 target Pxxx	0 ... 700		
P379	DI 3 bit selection	0000 ... FFFF		
P380	DI 3 LOW pattern	0000 ... FFFF		
P381	DI 3 HIGH pattern	0000 ... FFFF		
P342	DI 4 target Pxxx	0 ... 700		
P343	DI 4 bit selection	0000 ... FFFF		
P344	DI 4 LOW pattern	0000 ... FFFF		
P345	DI 4 HIGH pattern	0000 ... FFFF		

Parameter description

P382 DI state

This parameter indicates the state of input programming.

Bit no.	Meaning
0	1: input 1 completely programmed
1	1: input 2 completely programmed
2	1: input 3 completely programmed
3	1: input 4 completely programmed
4 ... 7	reserved
8	actual state input 1 (X26:15)
9	actual state input 2 (X26:16)
10	actual state input 3 (X26:17)
11	actual state input 4 (X26:18)
12 ... 13	reserved
14	actual state rapid halt input (X26:19)
15	actual state pulse / controller enabling (X26:14)

Parameters

P370 DI 1 target Pxxx

P374 DI 2 target Pxxx

P378 DI 3 target Pxxx

P342 DI 4 target Pxxx

This parameter indicates the parameter number of the target parameter for input 1 till 4.

P371 DI 1 bit selection

P375 DI 2 bit selection

P379 DI 3 bit selection

P343 DI 4 bit selection

The bits to be altered are selected in the target parameter.

P372 DI 1 LOW pattern

P376 DI 2 LOW pattern

P380 DI 3 LOW pattern

P344 DI 4 LOW pattern

Bit pattern which is written into the selected target parameter bits when digital input is LOW.

P373 DI 1 HIGH pattern

P377 DI 2 HIGH pattern

P381 DI 3 HIGH pattern

P345 DI 4 HIGH pattern

Bit pattern which is written into the selected target parameter bits when digital input is HIGH.

7.29 Digital Outputs

Function

The module enables programming of the three available digital outputs. Three parameters are assigned to each output:

- DI output ID no.: Input of source parameter number (only 2-byte parameters admissible)
- DI bit selection: Selection of source parameter bits to which bit pattern must correspond.
- DI bit pattern: If this bit pattern and the selected parameter bit pattern correspond to each other, the output is switched to HIGH.



NOTE

The following sequence must be observed for writing the parameters:

1. DA x source-Pxxx
2. DA x bit selection
3. DA x bit pattern

Note:

The sequence of the parameter setting is irrelevant. Switching takes place only after all three parameters have been set.

In order to deactivate an output either DI source Pxxx or DI bit selection must be set to 0. The last switch state, however, remains stored in the output. The output can be programmed again by setting the relevant parameter again.

Example of programming procedure:

1. Enter source parameter number in *DO x source Pxxx* of your choice.
 - Has no effect on the output yet.
2. Enter *DO x bit pattern* of the above mentioned parameter.
 - Has no effect on the output yet.
3. Enter *bit selection*:
 - All bits which have not been selected are set to 0 in the DO bit pattern, the bits selected from the source parameter are compared to the DO bit pattern. If one of the two patterns corresponds to the source parameter pattern, the output is set to HIGH.

Parameters

Example:

1. First set *DO 1 source Pxxx* to 13,
DO 1 bit pattern to 0001,
and *DO 1 bit selection* to 0003.

→ if bit no. 1 and bit no. 2 of parameter P013 result in „1“, the output 1 is switched to high.

2. Then set *DO 2 source Pxxx* to 13,
DO 2 bit pattern to 0003,
and *DO 2 bit selection* to 0003.

→ If bit no. 1 and bit no. 2 of parameter 13 result in „3“, the output 2 is set to high.

Parameter overview

Parameter	Name	Range min. ... max.	Unit	Display only
P383	DO 1 source Pxxx	0 ... 700		
P384	DO 1 bit selection	0000 ... FFFF		
P385	DO 1 bit pattern	0000 ... FFFF		
P386	DO 2 source Pxxx	0 ... 700		
P387	DO 2 bit selection	0000 ... FFFF		
P388	DO 2 bit pattern	0000 ... FFFF		
P389	DO 3 source Pxxx	0 ... 700		
P390	DO 3 bit selection	0000 ... FFFF		
P391	DO 3 bit pattern	0000 ... FFFF		
P392	DO state	0000 ... FFFF		×

Parameter description

P383 DO 1 source Pxxx

P386 DO 2 source Pxxx

P389 DO 3 source Pxxx

This parameter indicates the parameter number of the source parameter for outputs 1, 2 or 3.

P384 DO 1 bit selection

P387 DO 2 bit selection

P390 DO 3 bit selection

The bits to be compared are selected in the source parameter.

P385 DO 1 bit pattern

P388 DO 2 bit pattern

P391 DO 3 bit pattern

Bit pattern which is compared to the source parameter bit pattern.

P392 DO state

This parameter shows the state of the function module..

Bit no.	Meaning
0	1: output 1 completely programmed
1	1: output 2 completely programmed
2	1: output 3 completely programmed
3 ... 7	reserved
8	actual state output 1 (X26:21)
9	actual state output 2 (X26:22)
10	actual state output 3 (X26:23)
11 ... 15	reserved

7.30 External Digital Input

This function module in combination with the additional board MFM-01 enables the manipulation of 16 bit parameters (programming see Digital Inputs).

Parameter overview

Parameter	Name	Range min. ... max.	Unit	Display only
P500	XDI state	0000 ... FFFF		×
P501	XDI 1 target Pxxx	0 ... 700		
P502	XDI 1 bit selection	0000 ... FFFF		
P503	XDI 1 LOW pattern	0000 ... FFFF		
P504	XDI 1 HIGH pattern	0000 ... FFFF		
P505	XDI 2 target Pxxx	0 ... 700		
P506	XDI 2 bit selection	0000 ... FFFF		
P507	XDI 2 LOW pattern	0000 ... FFFF		
P508	XDI 2 HIGH pattern	0000 ... FFFF		
P509	XDI 3 target Pxxx	0 ... 700		
P510	XDI 3 bit selection	0000 ... FFFF		
P511	XDI 3 LOW pattern	0000 ... FFFF		
P512	XDI 3 HIGH pattern	0000 ... FFFF		
P513	XDI 4 target Pxxx	0 ... 700		
P514	XDI 4 bit selection	0000 ... FFFF		
P515	XDI 4 LOW pattern	0000 ... FFFF		
P516	XDI 4 HIGH pattern	0000 ... FFFF		
P517	XDI 5 target Pxxx	0 ... 700		
P518	XDI 5 bit selection	0000 ... FFFF		
P519	XDI 5 LOW pattern	0000 ... FFFF		
P520	XDI 5 HIGH pattern	0000 ... FFFF		
P521	XDI 6 target Pxxx	0 ... 700		
P522	XDI 6 bit selection	0000 ... FFFF		
P523	XDI 6 LOW pattern	0000 ... FFFF		
P524	XDI 6 HIGH pattern	0000 ... FFFF		
P525	XDI 7 target Pxxx	0 ... 700		
P526	XDI 7 bit selection	0000 ... FFFF		
P527	XDI 7 LOW pattern	0000 ... FFFF		
P528	XDI 7 HIGH pattern	0000 ... FFFF		
P529	XDI 8 target Pxxx	0 ... 700		
P530	XDI 8 bit selection	0000 ... FFFF		
P531	XDI 8 LOW pattern	0000 ... FFFF		
P532	XDI 8 HIGH pattern	0000 ... FFFF		

**NOTE**

The controller can reach the state „operation enabled“ immediately after the switch on of the electronic power supply, if the control word (see function module drive manager) is manipulated by digital input (see function module digital input) and the hardware enable is active.

During the programming of digital input this option must be considered and protective measures have to be ensured on machine-side.

Parameter description**P500 XDI state**

This parameter indicates the state of input programming.

Bit no.	Meaning
0	1: input 1 completely programmed
1	1: input 2 completely programmed
2	1: input 3 completely programmed
3	1: input 4 completely programmed
4	1: input 5 completely programmed
5	1: input 6 completely programmed
6	1: input 7 completely programmed
7	1: input 8 completely programmed
8	actual state input 1
9	actual state input 2
10	actual state input 3
11	actual state input 4
12	actual state input 5
13	actual state input 6
14	actual state input 7
15	actual state input 8

P501 XDI 1 target Pxxx

P505 XDI 2 target Pxxx

P509 XDI 3 target Pxxx

P513 XDI 4 target Pxxx

P517 XDI 5 target Pxxx

P521 XDI 6 target Pxxx

P525 XDI 7 target Pxxx

P529 XDI 8 target Pxxx

This parameter indicates the parameter number of the target parameter for input 1 till 8.

Parameters

P502 XDI 1 bit selection

P506 XDI 2 bit selection

P510 XDI 3 bit selection

P514 XDI 4 bit selection

P518 XDI 5 bit selection

P522 XDI 6 bit selection

P526 XDI 7 bit selection

P530 XDI 8 bit selection

The bits to be altered are selected in the target parameter.

P503 XDI 1 LOW pattern

P507 XDI 2 LOW pattern

P511 XDI 3 LOW pattern

P515 XDI 4 LOW pattern

P519 XDI 5 LOW pattern

P523 XDI 6 LOW pattern

P527 XDI 7 LOW pattern

P531 XDI 8 LOW pattern

Bit pattern which is written into the selected target parameter bits when digital input is LOW.

P504 XDI 1 HIGH pattern

P508 XDI 2 HIGH pattern

P512 XDI 3 HIGH pattern

P516 XDI 4 HIGH pattern

P520 XDI 5 HIGH pattern

P524 XDI 6 HIGH pattern

P528 XDI 7 HIGH pattern

P532 XDI 8 HIGH pattern

Bit pattern which is written into the selected target parameter bits when digital input is HIGH.

7.31 External Digital Outputs

This function module in combination with the additional board MFM-01 enables the output of 16 bit parameters (programming see Digital Outputs).

Parameter overview

Parameter	Name	Range min. ... max.	Unit	Display only
P533	XDO state	0000 ... FFFF		×
P534	XDO mode	000 ... 00FF		
P535	XDO 1 source Pxxx	0 ... 700		
P536	XDO 1 bit selection	0000 ... FFFF		
P537	XDO 1 bit pattern	0000 ... FFFF		
P538	XDO 2 source Pxxx	0 ... 700		
P539	XDO 2 bit selection	0000 ... FFFF		
P540	XDO 2 bit pattern	0000 ... FFFF		
P541	XDO 3 source Pxxx	0 ... 700		
P542	XDO 3 bit selection	0000 ... FFFF		
P543	XDO 3 bit pattern	0000 ... FFFF		
P544	XDO 4 source Pxxx	0 ... 700		
P545	XDO 4 bit selection	0000 ... FFFF		
P546	XDO 4 bit pattern	0000 ... FFFF		
P547	XDO 5 source Pxxx	0 ... 700		
P548	XDO 5 bit selection	0000 ... FFFF		
P549	XDO 5 bit pattern	0000 ... FFFF		
P550	XDO 6 source Pxxx	0 ... 700		
P551	XDO 6 bit selection	0000 ... FFFF		
P552	XDO 6 bit pattern	0000 ... FFFF		
P553	XDO 7 source Pxxx	0 ... 700		
P554	XDO 7 bit selection	0000 ... FFFF		
P555	XDO 7 bit pattern	0000 ... FFFF		
P556	XDO 8 source Pxxx	0 ... 700		
P557	XDO 8 bit selection	0000 ... FFFF		
P558	XDO 8 bit pattern	0000 ... FFFF		

Parameters

Parameter description

P533 XDO state

This parameter displays the state of output programming and outputs.

Bit no.	Meaning
0	1: output 1 completely programmed
1	1: output 2 completely programmed
2	1: output 3 completely programmed
3	1: output 4 completely programmed
4	1: output 5 completely programmed
5	1: output 6 completely programmed
6	1: output 7 completely programmed
7	1: output 8 completely programmed
8	actual state of output 1
9	actual state of output 2
10	actual state of output 3
11	actual state of output 4
12	actual state of output 5
13	actual state of output 6
14	actual state of output 7
15	actual state of output 8

P535 XDO 1 source Pxxx

P538 XDO 2 source Pxxx

P541 XDO 3 source Pxxx

P544 XDO 4 source Pxxx

P547 XDO 5 source Pxxx

P550 XDO 6 source Pxxx

P553 XDO 7 source Pxxx

P556 XDO 8 source Pxxx

This parameter indicates the parameter number of the source parameter for outputs 1 till 8.

P536 XDO 1 bit selection

P539 XDO 2 bit selection

P542 XDO 3 bit selection

P545 XDO 4 bit selection

P548 XDO 5 bit selection

P551 XDO 6 bit selection

P554 XDO 7 bit selection

P557 XDO 8 bit selection

The bits to be compared are selected in the source parameter.

P537 XDO 1 bit pattern

P540 XDO 2 bit pattern

P543 XDO 3 bit pattern

P546 XDO 4 bit pattern

P549 XDO 5 bit pattern

P552 XDO 6 bit pattern

P555 XDO 7 bit pattern

P558 XDO 8 bit pattern

Bit pattern which is compared to the source parameter bit pattern.

7.32 Function module "freely configurable statusword GP State"

This function module is available with software version 3.05 or higher.

Function

The function module copies individual bit information from up to 16 parameters into a common status word.

Parameter Overview

Parameter	Name	Range		Unit	Display only
		min.	... max.		
P450	GP Status	0000	... FFFF		×
P451	GP Info 1	0000	... FFFF		
:	:				
P466	GP Info 16	0000	... FFFF		
P467	GP Latch	0000	... FFFF		

Description of the parameters:

P450 GP Status

Bit No.	Meaning
0 ... 15	The function of the bits is defined in P451 to P466.

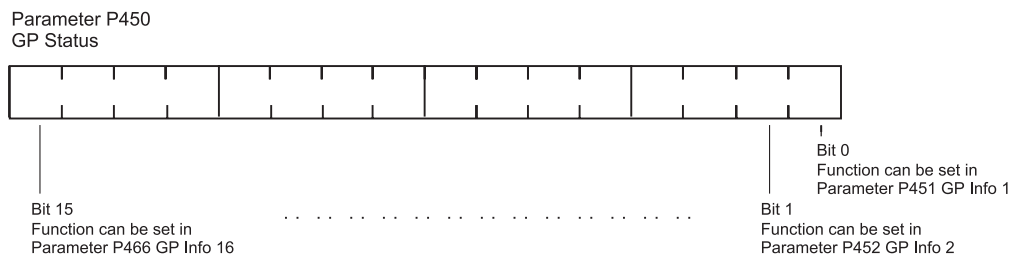

P451 GP Info 1

to

P466 GP Info 16

Bit No.	Meaning
0 ... 10	Parameter no. of the source parameter
11	Polarity bit 0 = positive logic (at a value of "1", the selected bit generates a "1" in GP Status) 0 = negative logic (at a value of "0", the selected bit generates a "1" in GP Status)
12 ... 15	Selected bit no. in the source parameter

Parameter P451 ... P466

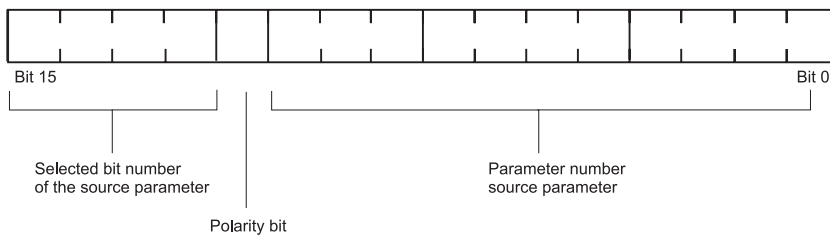

Example

Bit no. 1 from the status word of the drive manager (P121) and bit no. 8 from the status of the digital inputs (P382) shall be copied to the GP Status (P450) bit no. 0 and 1. The bit of the digital input status shall be set in GP Status, if input 1 is LOW.

Parameter P451

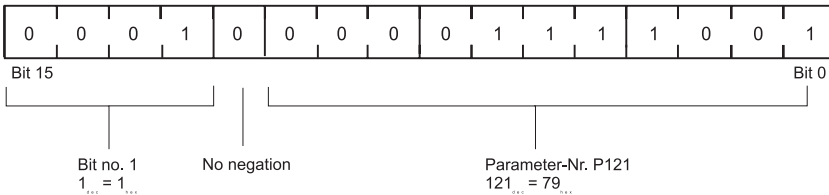

Parameter P452

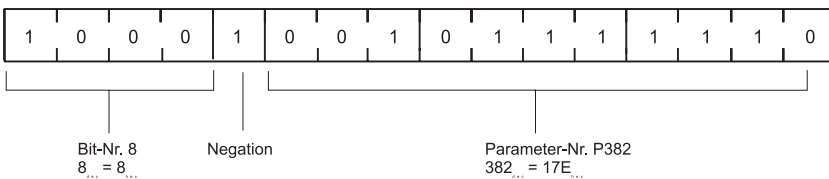

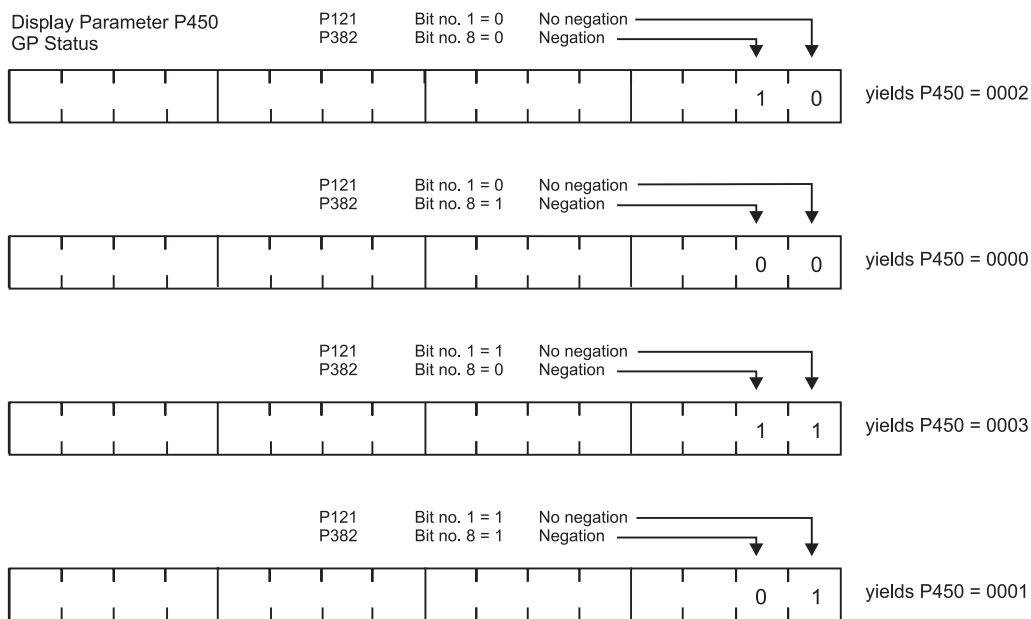

P467 GP Latch

ORing of P450 GP Status.

Bit No.	Meaning
0 ... 15	A set bit of this parameter indicates that this bit has already been set in GP Status. ("ORing"). The set bit can be reset by writing to P467 GP Latch.

7.33 Service Interface

Function

The service interface allows communication with the PC operating program. The BASS protocol is operated via the RS 232 interface X23.

The address of each drive is set in binary code at the controller front via DIP switch. Bit no. 0 thus corresponds to switch 1, bit no. 1 to switch 2 etc.

The RS 232 interface is constructed potential-free, the operating mode is full-duplex.

Data format: 8 data bits, 1 stop bit, no parity

Transmission speed: 9600 baud

Transmission format: ASCII

Communication PC ⇒ drive

BOF	ADDRESS	CONTROL	PARAMETER NO.	DATA	CHECKS.	EOF
-----	---------	---------	---------------	------	---------	-----

Example 1: Set P002 to 75 %

#	0	0	0	0	3	E	0	0	0	2	1	D	4	C	E	8	0D	0A
	Write operating data (one element, first transmission)							P002					1D4C = 7500 = 75 %					

Example 2: Read P051

#	0	0	0	0	3	C	0	0	3	3	F	D	0D	0A
	Read operating data (one element, first transmission)							P051						

Parameters

BOF # (23_{hex})
Address of the drive 0_{dec} to 255_{dec} (00_{hex} to FF_{hex})
Control

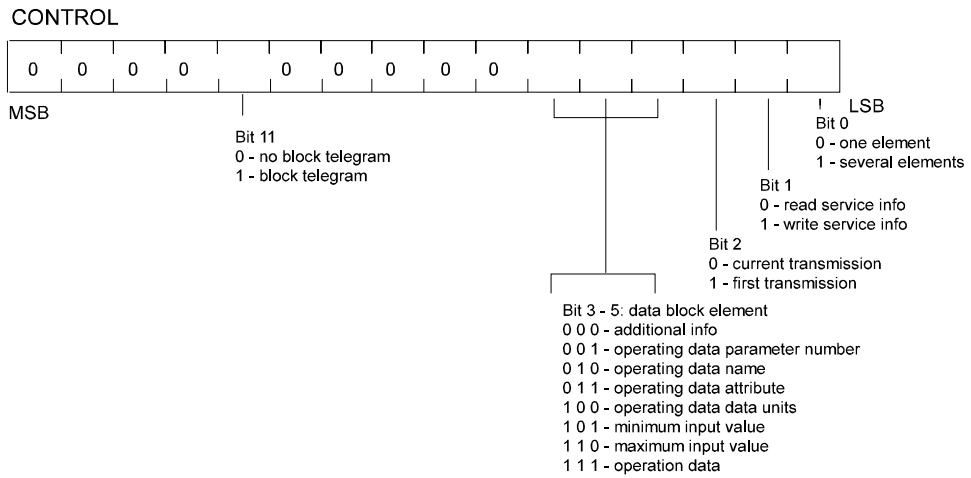

Parameter number Hexadecimal value of the parameter number as an ASCII character

Data Element, error type

- Number are given as hexadecimal numbers and are transmitted as ASCII characters
- The half-byte with the highest value is transmitted first
- Really text begins with two words following one after another which contains the length of the text:

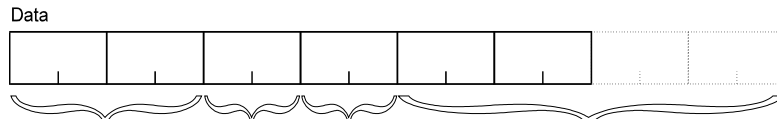
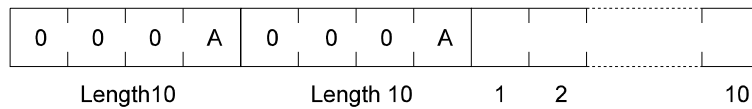

32 bit ASCII
no. of transmitted
block

16 bit HEX
number of
all trans-
mitted
blocks

16 bit HEX
size of the
transmitted
block

HEX
data

This number
is displayed on
the 14 lower bits
of P173.

This value
is trans-
mitted to
the DPRAM
address
09E h
(number of
all blocks).

This value
is trans-
mitted to
the DPRAM
address
09C h
(actual size
of block).

This data is transmitted to
the DPRAM and written
from address 0A0 h.

Checksum Sum of the hexadecimal values of all ASCII characters without BOF and EOF. Any overflow is also added (234_{hex} → 36_{hex})

EOF <CR> <LF> (0D_{hex}, 0A_{hex})

Communication drive ⇒ PC

Before the drive answered the echo telegram is sended from drive to PC!

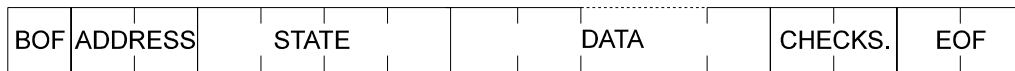

Example 1: Set P002 to 75 %

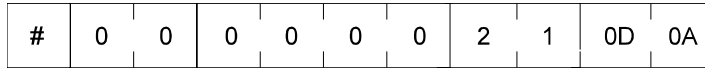

No error

Example 2: Read P051

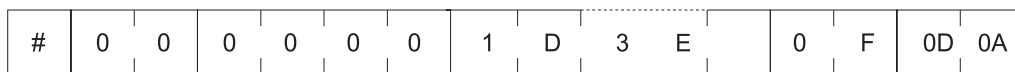

No error

1D3E =
7486 = 74,86 % N actual value

BOF

(23_{hex})

Address of the drive

0_{dec} to 255_{dec} (00_{hex} to FF_{hex})

State

STATUS

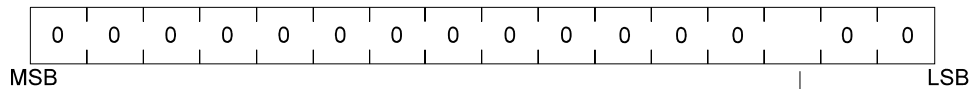

Bit 2
0 - kein Fehler
1 - Fehler im Service-Kanal

Parameter number

Hexadecimal value of the parameter number as an ASCII character

Data

Element, data state, error type

Really text begins with two words following one after another which contains the length of the text:

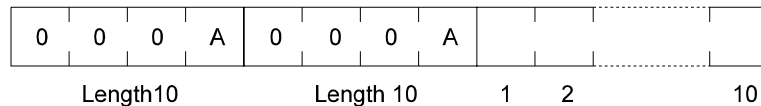

Checksum

Sum of the hexadecimal values of all ASCII characters without BOF and EOF. Any overflow is also added (234_{hex}→36_{hex})

EOF

<CR> <LF> (0D_{hex}, 0A_{hex})

Parameters

Error table

Error number	Meaning
0	No fault
1	Element is not available
2	Datum is too short
3	Datum is too long
4	Datum is not alterable
5	Parameter is write protected
6	Datum is smaller than minimum value
7	Datum is greater than maximum value
8	Datum is invalid
9	Obtaining of parameter is invalid

Parameter overview

Parameter	Name	Range min. ... max.	Unit	Display only
P170	SI state	0000 ... FFFF		×
P171	SI baud rate	50 ... 19200	Baud	×
P172	SI mode	0000 ... 0003		
P173	SI array state	0000 ... FFFF		×

Parameter description

P170 SI state

Write-access to the drive parameters is managed via parameter M communication source (P126) in the drive manager. The drive parameter can only be altered via the service interface when bit no. 0 of this parameter is set to 1. If the bit is set to 0 write-access is inhibited and only read-access to the parameter values granted.

See also M communication source (P126)

Bit no.	Meaning
0 ... 3	status of function module 0001: RUN (all parameters can be read and write) 0000: STOP (all parameters can be read only)
4 ... 11	drive address 0 ... 255 (representation of the DIP switch)
12 ... 15	reserved

P171 SI baud rate

The service baud rate can only be displayed and is set to a fixed value of 9600 baud.

P172 SI mode

Bit no.	Meaning
0	1: Standard setting All set and actual values are standardized in % 0: All set and actual values are transferred in internal standardization
1	1: Standard setting 0: Service mode
2 ... 15	reserved

P173 SI array state

Bit no.	Meaning
0 ... 3	Number of actual transferred block
4	Data in RAM puffer valid
5	Block is just written to RAM puffer

7.34 Link to USS® Protocol



NOTE

The USS® protocol is a registered trade mark of Siemens AG.

Function

The link to USS® protocol allows the user to carry out communication between master and slave with a fixed message length.

Data transmission and data save description

(Layer 1 and 2 in the ISO/OSI layer model)

The following arrangement applies to data transmission and data save:

1. The operating mode is strictly half-duplex.
2. It is a bus-capable master-slave protocol, where the non-system computer is the master. The drives are always the slaves.
3. Message length is fixed and cannot be altered on-line.
4. All messages must be transmitted completely, i.e. with no gaps in them. No acknowledgement or repeat messages are needed due to the cyclic message exchange.
5. The transmission framework for the individual characters is defined as follows:
1 start bit, 8 data bits, 1 parity bit (even parity), 1 stop bit.
The start character of each message (master and slave messages) is the ASCII character STX = 02hex in conjunction with a preceding transmission pause of 33 bits. All other characters in the message are not code-dependent.
A Hamming distance of $d = 4$ is attained via various data saving methods. This means that at least 4 bit errors per message must occur at defined places in the message before a faulty message is no longer recognised as such.

Message structure

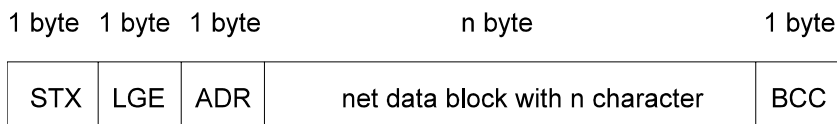

STX: Start of Text (02hex)

LGE: Message length 2 - 254 bytes (without STX and LGE, but with ADR and BCC)

ADR: Slave address 0 - 31; 32: broadcast message, = 64: mirror message

BCC: Block Check Character (EXOR linking of all characters)

Transmission procedure

The start character STX (02hex) is not itself enough to mark the start of a message, as this bit combination can also appear in the middle of the message e.g. in the net data block. Thus a transmission pause of 33 bits is stipulated for the master and slave messages. A valid start to a message is only marked when a received STX is preceded by a transmission pause. As a result of the semi-duplex operation (i.e. only transmission or reception at any one time), this start pause is guaranteed when in error-free operation.

The definition of the start pause requires that the pause time never comes between two characters within a message. For this reason, all messages are to be transmitted without gaps.

The drives only respond when they have received a complete and error-free message, sent to their address.

If a slave does not send a reply to a master message, this can result from the following:

- Slave is not yet switched on
- Slave has received a faulty message
- Communication cable is open-circuit or faulty
- Parameter M communication source (P126) bit no. 2 is not set to 1 (USS[®] protocol)

Normally, the slave sends a reply message for each master message after processing it briefly. Where there are more slaves in use, the procedure is shown in the following diagram:

2-wire and 4-wire modes (half duplex)

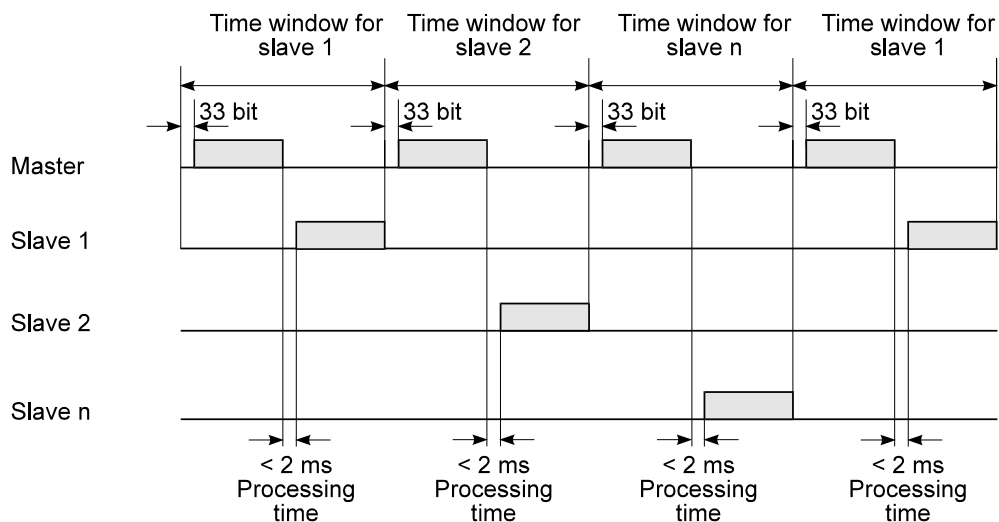

Structure of the net data block

The net data block is divided into two ranges:

- PIV (Parameter Identification Value) range
 - PD (Process Data) range
- Parameter exchange between the two communication partners, i.e. reading and writing of parameter values and reading of the parameter description is carried out via the PIV range.
 - The PD range contains necessary signals for automation:
 - control word and specified values from master to slave
 - status word and actual values from slave to master

Parameters

Both ranges comprise the net data block. This structure applies to the job message (Master → Slave) as well as the reply message (Slave → Master))

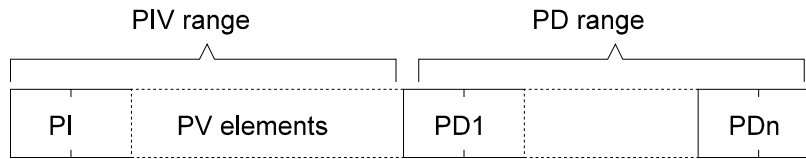

- PI: The parameter identifier (PI) serves to identify and issue jobs and replies for parameter processing, and always has word length (= 16 bits)
- PV element: Parameter value, if necessary with additional or other user data. If only PD data is to be transmitted in the net data block, the number of PV elements can be 0.
- PD1-PDn: Process data (control/status word and specified/actual values)
The necessary specified and actual values are transmitted in this range. The length of this range must be agreed between the drive and the control. If only PIV data is to be transmitted in the net data block, the number of PD elements can be 0.
Depending on the transmission direction, either the control word or the status word is to be transmitted in the PD1. The specified/actual values are transmitted in the following process data PD2 to PDn.

Bus addresses

The bus addresses are set, binary-coded, at the front of the controller with the help of DIP switch. DIP no. 1 thus corresponds to bit no. 0 of the bus address, DIP no. 2 to bit no. 1 etc.

Mirror message

The bus master can request a mirror message from the slave. The master transmits a message to the appropriate slave which only differs from a normal message in that bit no. 7 is set in the address byte ADR.

The slave transmits this message immediately after reception as a reply message to the master. The mirror message allows the transmission function between master and slave to be tested. This is useful e.g. for step-by-step commissioning or fault-finding in the bus system.

Broadcast message

A broadcast message is a master message transmitted simultaneously to all slaves, which only differs from a normal message in that bit no. 32 is set in the address byte ADR (bit no. 5 = 1).

Broadcast messages are not answered by the slaves. However, in this case the master does not expect a reply message.

Net data processing takes place as follows:

- Specified values in the PD range are not accepted
- Jobs in the PIV range are not processed
- The control word in PD1 is linked to its screen in PV1, so that only those bits in the drive control word are updated which are set to „1“ in the screen. The bits set to „0“ are not updated, their old status is retained.

Broadcast mode is only possible when the PIV number is set to > 3 and the PD number to > 1. In addition, the job identifier must be set to 0 „no job“.

If PIV number set equal 0 the control word are accepted without screen.

Structure of the PIV range

The structure of the PIV range is always the same in the sequence of its elements and only differs in its standard form by the number of its parameter values (PV).

The PIV range can be set to a specific length (3 or 4 words long) via parameter USS® PIV number (P183).

If no PIV range is to be available in the net data block, the PIV number must be set to 0, then parameters can be assigned via this interface.

- PIV range with set message length

Standard form with parameter values as word size
(PIV number = 3)

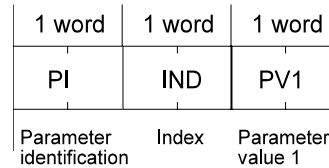

Standard form with parameter values as double word size
(PIV number = 4)

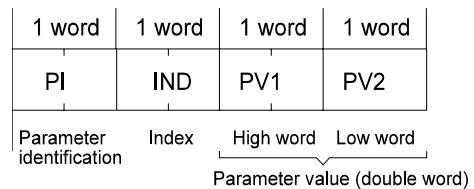

-applies to both job and reply messages.

- Description of the individual PIV elements

- Parameter identification (PI)

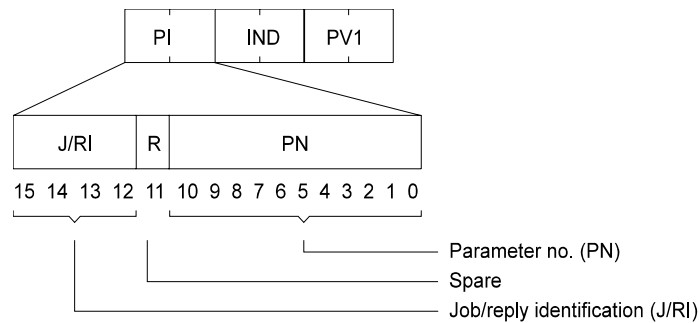

- Job and reply identification

The jobs which are sent from the master to the slave are coded in the job identification. The slave processes the job and formulates the relevant reply, which is coded (J/RI) and sent to the master. The J/RI specifies that jobs or replies are clearly defined via the PI (J/RI + PN) and, in the case of certain jobs/replies, additionally via the index word.

Parameters

Job identification (master → slave)

Bit no. 15 14 13 12				Function	Description
0	0	0	0	no job	no job for the PIV interface
0	0	0	1	request PV	requests a PV
0	0	1	0	change PV (word)	writes a PV word (16 bit)
0	0	1	1	change PV (double word)	writes a PV double word (32 bit)
0	1	0	0	request PDE element	reads an element from the parameter description (PDE); the element to be read can be found in IND.

Reply identification (slave → master)

Bit no. 15 14 13 12				Function	Description
0	0	0	0	no reply	no reply
0	0	0	1	transmit PV (word)	transmits a PV word (16 bit)
0	0	1	0	transmit PV (double word)	transmits a PV word (32 bit)
0	0	1	1	transmit PDE element	transmits an element from the parameter description (PDE); the element to be transmitted can be found in IND.
0	1	1	1	job cannot be processed	error identification in PV, see error identification list

Connection between a job and its reply

Job identification				Reply identification											
Identification				Function				Identifica- tion				Function			
0	0	0	0	no job				0	0	0	0	no reply			
0	0	0	1	request PV				0	0	0	1	transmits PV (word)			
								0	0	1	0	transmits PV (double word)			
0	0	1	0	change PV (word)				0	0	1	0	transmits PV (word)			
0	0	1	1	change PV (double word)				0	0	1	1	transmits PV (double word)			
0	1	0	0	request PDE element				0	0	1	1	transmits PDE element			

PDE elements

Value	Meaning
1	parameter attribute
2	parameter info
5	parameter minimum value
6	parameter maximum value

Parameter attribute

Bit	Meaning
0 - 1	length
2 - 3	type
4 - 5	number
6 - 7	element type
8 - 11	format
12 - 15	decimal places

Length: Data length of an element in bytes

00	1 byte
01	2 bytes
10	4 bytes
11	8 bytes

Type: Data type of an element

00	SIGNED	complete number with polarity sign
01	UNSIGNED	complete number without polarity sign
10	FLOAT	floating point number

Number: Element number

00	FIXED	one element
01	VARIABLE	variable number of elements

Element type:

00	DATA
01	COMMAND

Format: Display format

0000	BIN	binary
0001	DEC	decimal
0010	HEX	hexadecimal
0100	NORM	floating point without exponent
0101	FIX	floating point with fixed exponent
0110	SCI	floating point, scientific
0111	ENG	floating point, engineering
1000	ASCII	ASCII character

Decimal places:

0000	0	no decimal places
....		
1111	15	15 decimal places

Info

Info is 32 bits long, but only the lower value 16 bits are used. The 16 higher value bits are reserved for future applications.

Bit	Meaning
0 ... 2	write-protection
3	save mode
4 - 15	not assigned

Write-protection:

000	UNPROTECTED	not protected
001	PROTECTED	write-protection level 1

Save mode:

0	NONSTORE
1	STORE

Error identification list

If jobs cannot be processed, the receiver transmits the reply identification „job cannot be processed“ and transfers the corresponding error identification in parameter value (PV):

Identification	Description
0	Invalid PN
1	Parameter cannot be altered
2	MIN/MAX limitation
3	Faulty IND
4	No array
5	Wrong data type
6	No setting allowed
7	Description element cannot be altered
:	:
100	Reserved
101	Undefined error
102	Service not implemented
103	Parameter format too big for PIV range
104	PDE element not available

Job/reply processing

Job/reply processing describes the temporal and functional sequence of data transmission for the PIV interface between the master and the slaves.

- The transmitter may only give one job to one slave and must then wait for the corresponding reply identification. As long as it is waiting for the reply identification it must repeat the job.
- The job/reply must be transmitted completely in one message.
- Every alteration of the job means a new job, to which the corresponding reply must be made. Job identification „no job“ receives the reply identification „no job“.
- If no information from the PIV interface is required in cyclic mode, the job „no reply“ must be set.
- If there are large time differences between the cyclic message sequence and reply preparation in the unit, the reply to „old job“ is sent during the transition phase between „old job“ and „new job“ until the new job is received and its corresponding reply given.
- In the case of replies which contain parameter values, the slave always replies, on repetition of the message, with the current value.
- On initial establishment of communication between master and slave, during the transition phase the slave can only reply with the identification „no reply“.
- If the transmitter does not receive a reply identification which belongs to its job from the receiver, a corresponding reaction must be triggered in the transmitter.
- The receiver does not expect confirmation from the transmitter that its reply has been received.
- Recognition of an existing job by the master:
The transmitter recognises the correct reply message by evaluating the reply identification, the parameter number, if necessary via the value in IND and the parameter value.
- Recognition of a new job by the slave:
Every job given by the transmitter after reception of a valid reply to an old job is recognised as a new job.
- If the master transmits a broadcast message, the slaves do not send a reply message to the master.

Index (IND)

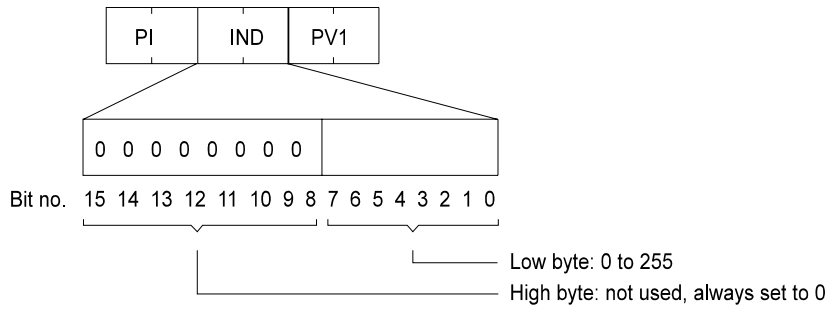

The index is used for writing and reading parameter descriptions.

In all other cases the index is carried as a „zero word“ in the message, i.e. all bits are set to 0.

Parameter value (PV)

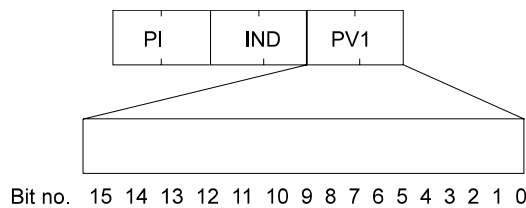

PV allocation is dependent on the existing job, or the corresponding reply.

PIV length for word sizes is always 3 words (PI, IND and PV)

PIV length for double word sizes is always 4 words (PI, IND and PV1 and PV2)

Structure of the PD range

The structure of the PD range is always the same in the sequence of its elements (= words) and only differs from its standard form by the length of the transmitted specified/actual values.

It covers a maximum of 3 words and a minimum of 0 words, i.e. no PD range in the net data block

Standard construction with specified/actual values as word size (PD number = 2):

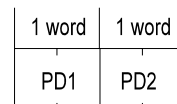

Control word Set value
State word Actual value

Standard structure with specified/actual values as double word size (PD number = 3):

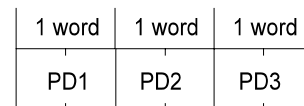

Control word High Low
state word word word

Set value
Actual value

Parameters

- Description of the individual PD elements

Control word and status word

The meaning of the bits in the control and status words is described in the drive manager under the parameters M control word (P120) and M status word (P121).

Specified/actual values

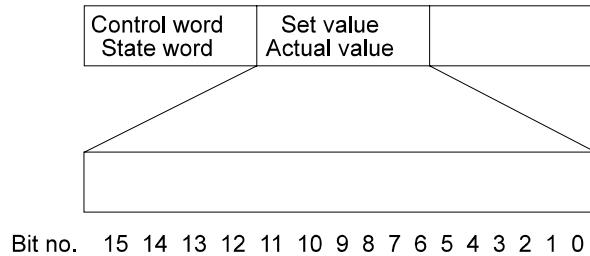

Transmission of specified and actual values in hex figures, where standardisation takes place according to the parameter.

Commissioning the bus system (fixed message length)

The following applies to commissioning communication with the USS[®] protocol with set message length:

- For communication between master and slave:
Job and reply messages have the same length, i.e. regarding their PIV range and their PD range.
- This length must be set to a fixed value before initial commissioning of the bus system and may not be altered during use.
- Fixed message length means fixed size of the net data block.
- The size setting of the net data block is via the 2 parameters USS[®] PIV number (ID no. 183) and USS[®] PD number (ID no. 184).
- If the master sets a job whose reply would exceed the set size of the PIV range, this job is answered with the reply identification „job cannot be processed“, e.g. the job „PV request double word“ cannot be processed with PV number = 3.
- Before setting the net data block size, specify which jobs are to be set by the master. The size of the PIV range is to be based on this. That is, if processing of double words is planned, the PIV range should always be set to 4 words, even if the processing of single words is likely to be more common.

Example messages:

- Example 1: PIV number = 3, PD number = 2
Assignment of word parameters or transmission of specified/actual word values is possible.

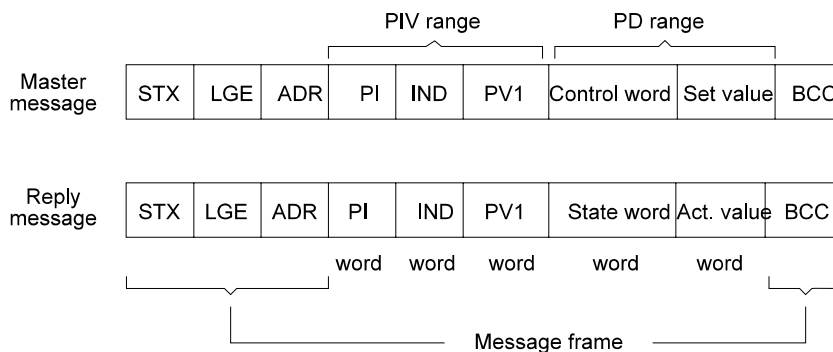

- Example 2: PIV number = 0, PD number = 3
Transmission of specified/actual word and double word values is possible. Parameter assignment via PIV range is not possible.

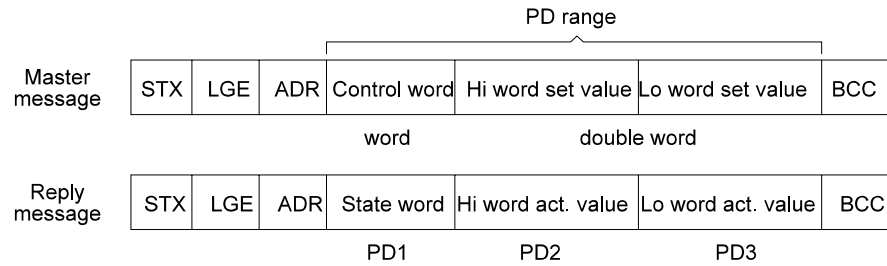

- Example 3: PIV number = 4, PD number = 0
Assignment of word and double word parameters is possible. Specified value entry and drive control is not possible.

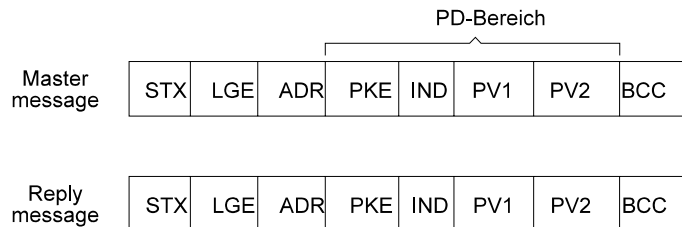

Parameter overview

Parameter	Name	Range min. ... max.	Unit	Display only
P180	USS [®] state	0000 ... FFFF		×
P181	USS [®] mode	0000 ... 0007		
P182	USS [®] baud rate	150 ... 19200	Baud	
P183	USS [®] PIV number	0 ... 4	Words	
P184	USS [®] PD number	0 ... 3	Words	
P185	USS [®] set value Pxxx	0 ... 700		×
P186	USS [®] actual value Pxxx	0 ... 700		×

Parameter description

P180 USS[®] state

Displays the internal status of the module.

The module function is set via parameter M communication source (P126) of the drive manager. For further details, see the relevant chapter..

Bit no.	Meaning
0 - 3	0000: state STOP. Incoming messages are not answered 0001: state RUN. Message evaluation is active.
4	1: no message received at own address for longer than 1 s
5	1: no message traffic on the bus for longer than 5 s
6	reserved
7	1: faulty module initialisation
8	1: format error on actual value transfer (see P186)
9	1: format error on set value transfer (see P185)
10	1: error on reading actual value
11	1: error on writing set value
12 - 15	reserved

P181 USS[®] mode

This parameter sets the USS[®] protocol mode.

Bit no.	Meaning
0	1: set/actual value standardization active, set and actual values are transmitted in % 0: set/actual value standardization inactive, set and actual values are transmitted in internal standardization (see internal standardization)
1	1: broadcast coding active 0: broadcast coding inactive
2	1: answer delay active 0: answer delay inactive
3 - 15	reserved

Specified and actual value standardisation is selected with bit no. 0.

Apart from specified and actual position values, all specified and actual value parameters are represented as relative sizes. With deactivated specified/actual value standardisation these parameters are represented in original standardisation in the message ($\pm 100.00\%$, ± 2048 etc.), with active standardisation they are referred to 4000h.

Broadcast coding is activated by bit no. 1.

In normal circumstances all of the maximum 32 bus participants are addressed when the broadcast-message is activated. By means of the Broadcast coding one can select for which drive this Broadcast message is set; only those specific drives react to the control word contained in the Broadcast message. The masking of this control word (with the masking of this control word (with the mask transmitted in the PV1 (PIV-range)) remains effective.

Following requirements must be satisfied for the use of Broadcast coding:

- USS[®] PIV number (P183) must be set → 3
- USS[®] PD number (P184) must be set → 3
- USS[®] mode (P181) bit no. 1 must be set = 1.

The significance of the Broadcast coding is indicated by the following example:
 Assuming: PD number = 3, PIV number = 3

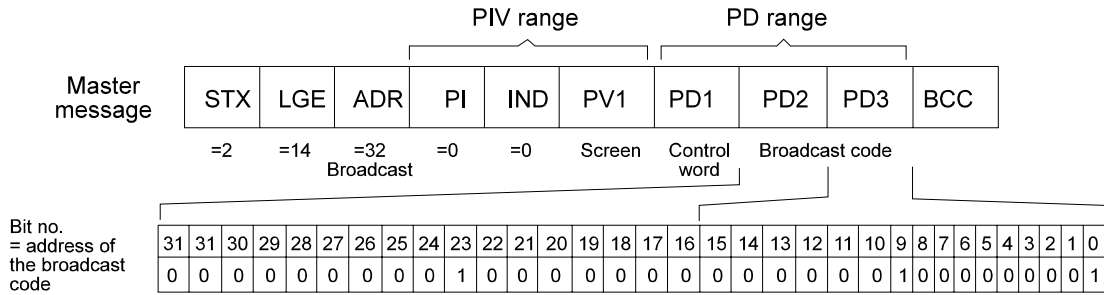

The Broadcast code is set in PD2 (high-word) and PD3 (low-word) and signifies, in this example, that the control word in PD1, masked with the value in PV1, must be accepted and executed by the bus participants with the address 0, 9 and 23. All other bus participants must disregard this information.

The answer delay is selected via bit no. 2

According to the specification of the USS[®] protocol the drive will transmit, after the reception of the master message, its answer message with a maximum delay of 2 ms. Within this short time span a thorough processing of the information contained in the master message will not always be possible (e.g. in PD range). Consequently a prepared answer message (with an incomplete content) is sent back to the master. The correct return answer is only then transmitted to the master in the next message-cycle (see arrow)

A nesting of the replies from one message cycle occurs.

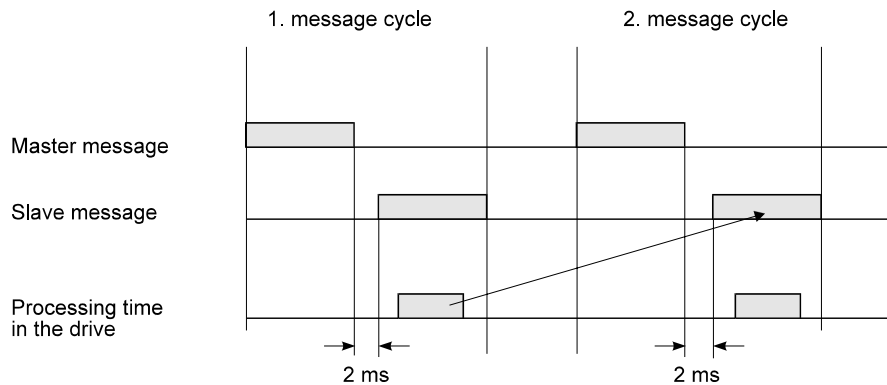

In activating the answer-delay (P181, bit no. 2 = 1) the information contained within processed, after the reception of the master message (and straight after the answer message has been transmitted back to the master (see arrow). A message-cycle is thus saved, however, uncertainty occurs as to exactly when the answer message is transmitted. If the answer-delay is activated then the message timing will no longer correspond to the specification.

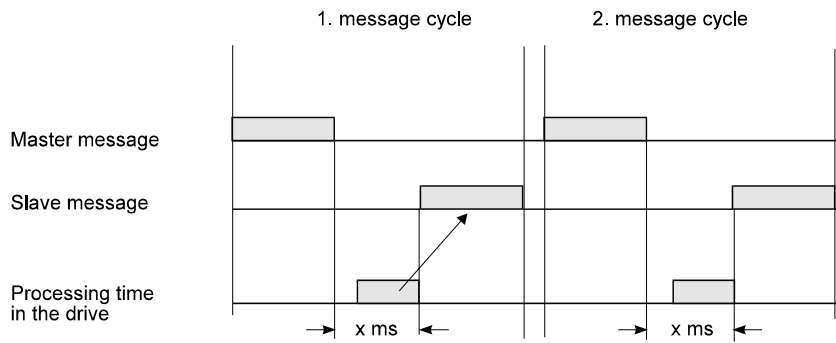

P182 USS® baud rate

This parameter sets the baud rate for the RS485 interface.

P183 USS® PIV number

This parameter sets the number of PIV elements available in the PIV range of the net data block. The specification always refers to PIV elements of word length.

Value	Meaning
0	0 words (no parameter assignment possible)
3	constantly 3 words (word parameter)
4	constantly 4 words (double word parameters)

P184 USS® PD number

The amount of process data contained in the user data block can be influenced by this parameters. The entry is always PD elements with word length.

Value	Meaning
0	no process data
1	control word / status word is transmitted in PD1
2	control word / status word and 16 bit set/actual values
3	control word / status word and 32 bit set/actual values

P185 USS[®] set value Pxxx

This parameter allows the selection of that drive parameter which is to be written with the set value from the master message (PD2, PD3). The following stipulation applies to the data exchange:

PD number	Actual value parameter format	Comments
0	16 / 32 bit	set value channel switched off
1	16 / 32 bit	set value channel switched off
2	16 bit	set value transmitted in PD2
2	32 bit	data transmission not possible, bit no. 9 is set in USS [®] state
3	16 bit	set value transmitted in PD3
3	32 bit	HI word of the set value transmitted in PD2 LO word of the set value transmitted in PD3

P186 USS[®] actual value Pxxx

This parameter allows the selection of that drive parameter whose value is to be transmitted as the actual value in the reply message (PD2, PD3). The following stipulation applies to the data exchange.

PD number	Actual value parameter format	Comments
0	16 / 32 bit	actual value channel switched off
1	16 / 32 bit	actual value channel switched off
2	16 bit	actual value transmitted in PD2
2	32 bit	data transmission not possible, bit no. 8 is set in USS [®] state
3	16 bit	actual value transmitted in PD3
3	32 bit	HI word of the actual value transmitted in PD2 LO word of the actual value transmitted in PD3

7.35 BAPS Communication

Function

The module controls the communication of the controller with the various option cards via dual port RAM. Data exchange between the controller and the DP-RAM takes place according to the BAPS (Baumüller drives parallel interface) specification.

Parameter overview:

Parameter	Name	Range min. ... max.	Unit	Display only
P175	BAPS WD state	0000 ... FFFF		×
P176	BAPS C master command	0000 ... FFFF		×
P177	BAPS C slave acknowledgement	0000 ... FFFF		×
P178	BAPS C state	0000 ... FFFF		×

Parameter description

P175 BAPS WD state

This parameter shows the state of working data communication

Value	Meaning
0	no communication
1	communication in operation

P176 BAPS C master command

Command word of master.

Value	Meaning
00	no meaning
01	cyclic data exchange
02	write configuration initialise communication
03	up to software 3.09: reserved software 3.09 or higher: write configuration re-initialise communication
04 ... FE	reserved
FF	no meaning

P177 BAPS C slave acknowledgement

Acknowledgement by slave.

Value	Meaning
00	no meaning
01	set values read, actual value written
02	configuration / initialisation carried out correctly
03	up to software 3.09: reserved software 3.09 or higher: re-initialisation startet
04 ... 7F	reserved
80	illegal instruction received
81	no configuration / initialisation carried out
82	actual value cannot be read (configuration)
83	set value cannot be written (configuration)
84 ... 85	
86	up to software 3.09: reserved software 3.09 or higher: actual value re-initialisation faulty
87	up to software 3.09: reserved software 3.09 or higher: set value re-initialisation faulty
88 ... FE	reserved
FF	no meaning

P178 BAPS C state

State of cyclic communication.

Bit no.	Meaning
0 ... 3	0: communication inhibited 1: communication enabled
4	1: communication initialised
8	1: timeout

7.36 Additional Parameter

Function

These parameters are only used by the optional boards to store the data in the V-controller EEPROM.

Parameter overview

Parameter	Name	Range min. ... max.	Unit	Display only
P478	ZK 0	0000 ... 8000	-	
	.	.		
	.	.		
	.	.		
P499	ZK 31	0000 ... 8000	-	

7.37 Objekt list

The object list supports the communication between intelligent add-on boards and different controller types (e.g. E-controller, V-controller, BKF 7000,)

PO17 OL Index

Input value for accessing the object list

PO18 OL Value

Output value of the object list

Object list

Obj. no.	Designation	BUS6V
0	Controller identifier	Value = 0
1	M control word	P120
2	M status word	P121
3	Communication monitoring time	P128
4	Rated RPM speed	P019
5	Specified value 1	P002
6	Actual value	P051
7	ZK 0	P468
8	Specified value 2	P004
9	Specified value 3	P006
10	Specified value selection	P013
11	M operating mode target	P122
12	Pos current record no.	P401
13	RFG output	P001
14	RFG ramp-up time 1	P003
15	RFG ramp-up time 2	P005
16	RFG ramp-up time 3	P007
17	RFG ramp-down time 1	P010
18	RFG ramp-down time 2	P011
19	RFG ramp-down time 3	P012
20	RFG ramp-down time quick stop	P009
21	M operating mode actual	P123
22	M STOP code	P130
23	M QUICK STOP Code	P131
24	M INHIBIT Code	P132
25	M SHUTDOWN code	P133
26	Program version	P163
27	Position specified value	P208
28	Position actual value	P209
29	Pos reference speed	P412

Obj. no.	Designation	BUS6V
30	Pos reference acceleration	P413
31	Pos reference travel mode	P414
32	Pos target position 1	P415
33	Pos target position 2	P422
34	Pos pos.-window	P429
35	Pos pos. window time	P430
36	Error code	P124
37	Error index	P125
38	Communication source	P126
39	DRM command	P190
40	DRM status	P191
41	DRM message	P192
42	DRM record name	P193
43	Specified value at the speed controller	P050
44	Sync slot	P167
45	Kv factor position controller	P202
46	Pos reference point	P432

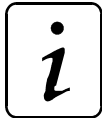

NOTE

Non-existing values must be set to 0.

8 MAINTENANCE



WARNING

The equipment carries a dangerously high voltage and has dangerous rotating parts (fans). Ignoring the safety and warning information may result in death, severe personal injury or damage to property.

You may only carry out maintenance when the unit is deenergized.

Do not begin work on the power stage and the intermediate circuit until you have made sure that the unit is not carrying potential or a voltage (remanent charge).

When dismantling safety devices during commissioning, repair and maintenance work, you must ensure that the machine is taken out of commission exactly as specified. You must remount and check safety equipment immediately after completing commissioning, repair and maintenance work.

After carrying out any work involving intervention in the machine – regardless of whether this involves the motor, the actual value acquisition or the power converter – the owner must carry out acceptance testing and document it chronologically in the machine log. Failure to do this may result in the owner being faced with consequences relating to liability legislation.

Do not start work on the power unit, intermediate circuit until you have made sure that the unit is not carrying potential or a voltage (remanent charge).

8.1 Maintenance Information

The units supplied are maintenance-free.

Prohibition of unauthorized modifications

For safety reasons, unauthorized additions or modifications to the drive are not allowed.

8.2 Error Messages

In the event of an error, parameter M error code (P124) indicates the appropriate error code. This error is acknowledged when bit Reset disturbance in M control word (P120) is set from 0 to 1. If there is more than one error, the system shows the next one immediately after acknowledgement.

- **Drive Manager Function Module (Error ID 00xx)**

Error ID	Error Text	Meaning	Error reaction	Remedy
0001 _{hex}	BASS protocol timeout	The communications source set in P124 has not responded for longer than the timeout set in P128.	Error reaction can be set in P189	Check communications (cables, daughterboard, etc.)
0002 _{hex}	USS protocol timeout			
0003 _{hex}	Dual-Port RAM time-out (cyclical data)			
0004 _{hex}	Dual-Port RAM time-out (working data)			
0005 _{hex}	System boot procedure	An error was determined while reading the boot data set from the EEPROM. You can get more information about the type of error by referring to parameter DSM Message (P192). This disturbance usually occurs if you replaced the controller firmware with firmware that is incompatible.	Inhibit pulses immediately	You should carefully check the data set in the controller's RAM and then program it in the EEPROM as the boot data set.
0006 _{hex}	Time-out error response	In case of an error (nonfatal error), the drive could not be braked down to n=0 within the time specified in P188.	Immediate pulse inhibit	Clarify the cause of the too long braking time. If necessary, increase P188 M fault response time.
0010 _{hex}	Error switch (program error)	Only meaningful for software developers	Inhibit pulses immediately	

- **Power Supply Function Module (Error ID 01xx)**

Error ID	Error Text	Meaning	Error reaction	Remedy
0110 _{hex}	Disturbance in power supply unit	No ready for use signal from supply unit.	Inhibit pulses immediately	Check the power supply. Reset the error memory in the power supply unit (refer to the power supply unit's operating instructions)

- **Power Unit Function Module (Error ID 02xx)**

see also Function Module Processor Error Recognition (Error ID 0Cxx) on page 235

Error ID	Error Text	Meaning	Error reaction	Remedy
0201 _{hex}	Overvoltage Uzk	The bus voltage, U_{ZK} , has exceeded a value of $800\text{ V} \pm 1\%$	Inhibit pulses immediately	Check the ballast resistor. If no ballast resistor is available see P269.
0202 _{hex}	Overcurrent	At least one of the power unit's three phase currents has overwritten the value of $1,3 \times I_{\max}$ ($\hat{=} 1,3 \times P113$)	Inhibit pulses immediately	Check the current controller's setting
0203 _{hex}	Error current	An error current was determined in the power unit that exceeded a specific amount. (For more detailed information, refer to the power unit description.)	Inhibit pulses immediately	Check the motor cables for a ground fault
0204 _{hex}	Disturbance in auxiliary voltage supply	There is no power supply for transistor control in the power unit.	Inhibit pulses immediately	Check control of the safety relay
0205 _{hex}	Overtemperature of power unit	The temperature of the power unit has risen above 85° C .	Error reaction can be set in P189	The disturbance cannot be acknowledged until the power unit temperature shown in P118 has fallen below 85° C .
0206 _{hex}	Disturbance in safety relay	The safety relay in the power unit is OFF even though it should be ON. This means that the auxiliary voltage supply for transistor control is deactivated.	Inhibit pulses immediately	Check control of the safety relay. Check in addition the setting of bit 2 in P090 PU mode.
0207 _{hex} 0208 _{hex} 0209 _{hex} 020A _{hex} 020B _{hex} 020C _{hex} 020D _{hex}	Transistor error (group message) Phase U top Phase U bottom Phase V top Phase V bottom Phase W top Phase W bottom	U_{CE} monitoring of one or more power transistors has tripped due, for example, to a short circuit or ground fault or because of defects in the transistor.	Inhibit pulses immediately	Check the motor cables for a short circuit or ground fault. Allow the power unit to cool down. If the disturbance keeps occurring, replace the power unit.
020E _{hex}	Power unit ID unknown	The control unit does not know the read identifier	Inhibit pulses immediately	Read off the power unit version from the rating plate and compare it with the list in P117. The error cannot be acknowledged.
020F _{hex}	Wrong power unit type	The stored power unit type does not match the one the system read, e.g. because no data set has been stored yet or you plugged the control unit into another power unit.	Inhibit pulses immediately	Check the parameterization and, if necessary, change it. Save the data set and acknowledge the error.
0210 _{hex}	Disturbance in power unit	The ready for use signal from the power unit is missing even though there are no other power unit disturbance messages.	Inhibit pulses immediately	Refer to the power units operating instructions.
Continued on next page				

0D01 _{hex}	Short circuit temperature sensor	The power unit temperature is below the temperature threshold of -40°C. Normally, this disturbance occurs if there is a short circuit in the temperature detection during operation.	Error response can be set in P189. Error activation via P090	Temperature detection defective, the disturbance cannot be eliminated.
---------------------	----------------------------------	--	---	--

• **Encoder Manager Function Module (Error ID 03xx)**

Error ID	Error Text	Meaning	Error reaction	Remedy
0301 _{hex}	Overspeed of encoder 1	Evaluation has determined a speed actual value (P023) that is greater than the overspeed value (P046)	Inhibit pulses immediately	Check the encoder cable. Check the speed controller settings.
0302 _{hex}	Overspeed of encoder 2	Encoder has determined a speed actual value (P243) that is greater than the overspeed value (P239)	Inhibit pulses immediately	Check the encoder cable. Check the speed controller settings.
0303 _{hex}	Absolute position encoder 1 unknown (rotor position)	The error occurs in conjunction with operation of synchronous control on these encoders in the following cases: 1. At initialization of the encoder, it was not possible to read the absolute position from the encoder (e.g. due to the encoder adaptor module, lack of communication).	Inhibit pulses immediately	
0304 _{hex}	Absolute position encoder 2 unknown (rotor position)	2. The encoder has no absolute position information (e.g. incremental encoders with sinus or square wave signals).		

• **Overload Monitoring Function Module (Error ID 04xx)**

Error ID	Error Text	Meaning	Error reaction	Remedy
0401 _{hex}	I ² t monitoring of motor	Calculated I (P091) is greater than 100%	Error reaction can be set in P189	Leave the drive in the inhibited status until the I ² t actual value (P091) drops below 100%.

- **Motor Temperature Function Module (Error ID 05xx)**

Error ID	Error Text	Meaning	Error reaction	Remedy
0501 _{hex}	Overtemperature of motor	P152 = 1 (sensor) The motor temperature has exceeded the shutdown threshold (P156). This disturbance may also occur, if the motor temperature detection is interrupted during operation.	Error response can be set in P090.	Allow the motor to cool down until the motor temperature has dropped below the limit value. Check the encoder cable and the temperature sensor (see motor temperature connector X28)
0502 _{hex}	Short circuit temperature sensor	P152 = 1 (sensor) The motor temperature is below the temperature threshold of -40°C. Normally, this disturbance occurs if there is a short circuit in the temperature detection during operation.	Error response can be set in P189.	Check the encoder cable and the temperature sensor (see motor temperature connector X28)

- **Position Controller Function Module (Error ID 06xx)**

Error ID	Error Text	Meaning	Error reaction	Remedy
0601 _{hex}	Deviation, dynamic	In motion, e.g. positioning, synchronous operation, the deviation (P210) has become greater than the dynamic deviation error limit (P203).	Error reaction can be set in P189	Check the settings of the dynamic deviation limit and, if necessary, correct them. Reset the error enable for the dynamic deviation in mode parameter P201, bit number 0.
0602 _{hex}	Deviation, static	At standstill (e.g. target position reached, n=0), the deviation (P210) has become greater than the static deviation error limit (P212).	Error reaction can be set in P189	Check the settings of the static deviation limit and, if necessary, correct them. Reset the error enable for the dynamic deviation in mode parameter P201, bit number 1.

- **Speed Controller Function Module (Error ID 07xx)**

Error ID	Error Text	Meaning	Error reaction	Remedy
0702 _{hex}	Blocking monitoring	During the blocking time set in P056, the drive was stationary with maximum torque of N = 0.	Error reaction can be set in P189	Check the drive machine for blocking

- Encoder 1 Function Module (Error ID 08xx)

Error ID	Error Text	Meaning	Error reaction	Remedy
0801 _{hex} *)	Invalid module code	The adapter module's code is not known	Inhibit pulses immediately	The adapter module is either not fitted or not supported in this version of the firmware
0802 _{hex} *)	Wrong adapter module	The encoder adapter in the unit is not suitable for the desired encoder type and communications protocol settings.	Inhibit pulses immediately	Change the settings in the encoder mode or use another adapter
0803 _{hex} *)	No communication with the encoder	Reading the absolute position from the encoder did not function.	Inhibit pulses immediately	Check the encoder cable, on the motor and unit sides.
0804 _{hex} **)	Wire break encoder 1	The encoder signals are useless for evaluation.	Inhibit pulses immediately	Check the encoder cable, on the motor and unit sides.
0805 _{hex}	Wrong address in the reply message		Immediate pulse inhibit	If this error occurs more than 3 times in a row despite all the EMC interference suppression measures taken, the encoder must be replaced.
0806 _{hex}	Encoder reports error	The encoder has detected an internal error during the self-test.	Immediate pulse inhibit	
0807 _{hex}	Wrong command in the reply message		Immediate pulse inhibit	
0808 _{hex}	Wrong checksum in the reply message		Immediate pulse inhibit	
0809 _{hex}	Error position correction		Immediate pulse inhibit	Check the encoder cable on the motor side and the device side.
080A _{hex}	Unknown encoder code	The encoder cannot be clearly identified due to an unknown encoder code.	Immediate pulse inhibit	
080B _{hex}	Communication timeout error	Encoder does not send a reply message within 50 ms.	Immediate pulse inhibit	
080C _{hex}	Error in SinCos tracks of the encoder	Failure in the signal level of the encoder's sinus and cosinus tracks.	Immediate pulse inhibit	Check the encoder cable on the motor side and the device side.
080D _{hex}	Field angle error	Calculated model field angle and measured field angle differ more than the tolerance of +/- 45°	Immediate pulse inhibit	Check the encoder cable on the motor side and the device side.

*) Errors cannot be acknowledged.

**) After acknowledgement, the encoder is reinitialized; in this connection, the reference to a reference point can be lost.

- **Data Set Management Function Module (Error ID 09xx)**

Error ID	Error Text	Meaning	Error reaction	Remedy
0901 _{hex}	EEPROM copy error	A data difference was determined at copying of the EEPROM during initialization of data set management	Error reaction can be set in P189	This error cannot be acknowledged and you can only eliminate it by switching the electronics supply off and on again. If the error occurs repeatedly, this indicates that there is a defect in the controller hardware.
0902 _{hex}	Missing boot data set	There is no boot data set (DS no. 0) in the EEPROM	Error reaction can be set in P189	You must create the boot data set in RAM and then save it to the EEPROM.
0903 _{hex}	Checksum error in boot data set	At checking of the boot data set, the system calculated a different checksum than the one that was expected, i.e. a boot data set is present but it is invalid due to data corruption.	Error reaction can be set in P189	You must create the boot data set in RAM and then save it to the EEPROM.

- **Encoder 2 Function Module (Error ID 0Axx)**

Error ID	Error Text	Meaning	Error reaction	Remedy
0A01 _{hex})	Invalid module code	The adapter module's code is not known	Inhibit pulses immediately	The adapter module is either not fitted or not supported in this version of the firmware
0A02 _{hex})	Wrong adapter module	The encoder adapter in the unit is not suitable for the desired encoder type and communications protocol settings.	Inhibit pulses immediately	Change the settings in the encoder mode or use another adapter
0A03 _{hex})	No communication with the encoder	Reading the absolute position from the encoder did not function.	Inhibit pulses immediately	Check the encoder cable, on the motor and unit sides.
0A04 _{hex})	Wire break encoder 2	The encoder signals are useless for evaluation.	Inhibit pulses immediately	Check the encoder cable, on the motor and unit sides.
0A05 _{hex}	Wrong address in the reply message		Immediate pulse inhibit	If this error occurs more than 3 times in a row despite all the EMC interference suppression measures taken, the encoder must be replaced.
0A06 _{hex}	Encoder reports error	The encoder has detected an internal error during the self-test.	Immediate pulse inhibit	
0A07 _{hex}	Wrong command in the reply message		Immediate pulse inhibit	
0A08 _{hex}	Wrong checksum in the reply message		Immediate pulse inhibit	
Continued on next page				

0A09 _{hex}	Error Position correction		Immediate pulse inhibit	Check the encoder cable on the motor side and the device side.
0A0A _{hex}	Unknown encoder code	The encoder cannot be clearly identified due to an unknown encoder code.	Immediate pulse inhibit	
0A0B _{hex}	Communication time-out error	Encoder does not send a reply message within 50 ms.	Immediate pulse inhibit	
0A0C _{hex}	Error in SinCos tracks of the encoder	Failure in the signal level of the encoder's sinus and cosinus tracks.	Immediate pulse inhibit	Check the encoder cable on the motor side and the device side.
0A0D _{hex}	Field angle error	Calculated model field angle and measured field angle differ more than the tolerance of +/- 45°	Immediate pulse inhibit	Check the encoder cable on the motor side and the device side.

*) Errors cannot be acknowledged.

**) After acknowledgement, the encoder is reinitialized; in this connection, the reference to a reference point can be lost.

• Operating System Function Module (Error ID 0Bxx)

Error ID	Error Text	Meaning	Error reaction	Remedy
0B01 _{hex}	Main program computing time exceeded		Error reaction can be set in P189	P160 selection = 0, P169 value = 0, Store the data set again and acknowledge the error. If necessary deactivate functions not needed for instance digital and analog I/O's by parameterization
0B02 _{hex}	Task computing time exceeded		Error reaction can be set in P189	
0B03 _{hex}	Sync. IR computing time exceeded		Error reaction can be set in P189	
0B04 _{hex} *	DSP computing time exceeded		Inhibit pulses immediately	

*) Errors cannot be acknowledged.

- **Function Module Processor Error Recognition (Error ID 0Cxx)**

Error ID	Error Text	Meaning	Error reaction	Remedy
0B05 _{hex}	Error in linking the program modules		Immediate pulse inhibit	Test the RAM
0B06 _{hex}	Error in the time segment system configuration			
0C01 _{hex}	illegal external bus access	Further information see memory 0xFA00 up to 0xFA0F.	Inhibit pulses immediately	re-boot controller
0C02 _{hex}	illegal instruction access			
0C03 _{hex}	illegal word operand access			
0C04 _{hex}	protection fault			
0C05 _{hex}	undefined opcode			
0C06 _{hex}	stack underflow			
0C07 _{hex}	stack overflow			
0C08 _{hex}	external non maskable interrupt			
0C09 _{hex}	watchdog time-out			

- **Function Module Power Unit continued (Error ID 0Dxx)**

Error identification	Error text	Meaning	Error response	Disturbance elimination
0D01 _{hex}	Short circuit of the temperature sensor (power unit)		Error response can be set in P189. Error activation via P090	

8.3 Disposal

For the most part, the equipment consists of the following components and materials:

Component	Material
Various spacers, housing of current converter and unit fan, etc.	Plastic
PCBs on which all the open- and closed-loop electronics are mounted	Base material: Epoxy-resin fiberglass woven material, copper-coated on both sides and plated-through, various electronic components such as condensers, resistors, relays, semi-conductors, etc.

For technical reasons, electronic components might need to contain dangerous materials, so you should not open them.

If the components are used correctly, there is no danger to human beings or to the environment.

In case of fire, dangerous compounds may result or hazardous materials may be released.

You must dispose of or recycle equipment or components according to national regulations as well as any applicable local or regional ordinances.

9 APPENDIX

9.1 Manufacturer Declaration

HERSTELLERERKLÄRUNG IN SINNE DER EG-MASCHINENRICHTLINIE 89/392/EWG, ANHANG IIB

Manufacturer Declaration in Accordance with the EC-Machine Guidelines 89/392/EEC, Appendix II B

Hiermit erklären wir, dass es sich bei dieser Lieferung um die nachfolgend bezeichnete Maschinenkomponente handelt und dass ihre Inbetriebnahme solange untersagt ist, bis festgestellt wurde, dass die Maschine, in die diese Komponente eingebaut ist, den Bestimmungen der EG-Maschinenrichtlinie 89/392/EWG, Anhang II B entspricht.

We herewith declare that this delivery includes the following specified machine component and that its putting into operation is prohibited until the declaration is made that the machine, in which this component is built in, complies with the regulations of the EC-machine guideline 89/392/EWG, appendix II B.

Bezeichnung der Maschinenkomponente:
Specification of the machine component:

Typenbezeichnung:
Type:

V-Regler (BUS 6 VC)

BUS 6 V - - - - - - - - - -

Nürnberg, 15.12.2004

Hersteller-Unterschrift:
Signature of the Manufacturer:

Andreas Baumüller
Geschäftsführer
Head Division

i.A. Dr. Heidrich
Entwicklungsleiter
Head of development

Seite 1 von 1 / page 1 of 1

9.2 General Conditions of Sale and Delivery

1. Obligation and Conclusion of Contract

- a) Deliveries of goods and provision of services shall be effected exclusively based on these trading conditions. They are an essential component of the contracts for delivery and shall be considered as having been accepted by the placing of an order. In the case of constant business relations, they also apply for the future contracts.
- b) Agreements diverging from the contract and verbal collateral agreements shall only be binding if they have been confirmed in writing by Baumüller Nürnberg GmbH (hereinafter referred to as Baumüller). Diverging trading conditions on the behalf of the purchaser shall be without obligation, even where these have not been expressly objected to. These General Conditions of Sale and Delivery shall be considered as having been accepted by the purchaser at the latest when the delivery is accepted.
- c) In as far as deliveries of goods are subject to separate external obligations in accordance with the Law Concerning Foreign Trade and Payments with respect to the Federal Office for Economics, the purchaser has to observe the relevant conditions at his/her own responsibility.

2. Price and Offers

Offers are subject to confirmation, not binding and apply subject to material supply possibilities. Supplements and amendments require written confirmation. Prices are ex works and are subject to confirmation. Invoicing takes place in accordance with the prices valid on the date of delivery.

3. Extent of Delivery and Delivery Time

- a) Specified delivery periods/dates are without obligation, in as far as nothing else to the contrary has been expressly agreed upon in writing. Delivery periods do not commence until the purchaser has fulfilled all duties of co-operation, in particular regarding details of performance. In the event that the agreed deposits for orders are delayed, then the delivery time shall be extended accordingly.
- b) The purchaser is entitled, in particular in the event of a delay in delivery of longer than 3 months, to set an appropriate period of grace and after its expiry, to withdraw from the order. Claims to compensation due to non-fulfilment or delay shall be excluded, in as far as Baumüller is not responsible for intent or gross negligence.
- c) Baumüller is entitled at any time to effect partial deliveries and partial services, as well as to invoice these accordingly.

4. Delivery Problems

- a) Delays/preventions in the delivery of goods or the provision of services due to force majeure entitle Baumüller to delay the production and delivery by the duration of the obstruction plus an appropriate period of time or to withdraw in part or in whole from the order.
- b) Industrial disputes or other circumstances which substantially impede or render impossible the delivery, such as, in particular, disturbances in the operating processes, problems in procuring materials, official directives also apply as force majeure, irrespective of whether they arise with regard to Baumüller or suppliers.
- c) In these cases, Items 4 a), b), the purchaser shall have no claim to compensation due to non-fulfilment or delay of the delivery.

5. Packaging

Items for sale and delivery items are packaged and transport insurance policies are taken out according to the

instructions of and at a cost to the purchaser. Upon demand, the packaging material has to be returned without delay, free of freight charges and expenses.

6. Dispatch and Passing of Risk

Deliveries shall be made ex works. The dispatch shall be effected at a cost to and at the risk of the recipient of the service/the purchaser. The risk passes to the recipient of the delivery/purchaser as soon as the delivery items leave the works. This shall apply at the latest, from the transfer of the delivery items to the person carrying out the transport, forwarding agent or carrier.

7. Warranty

- a) The period of warranty amounts to 12 months from the day of dispatch.

In the event that a delivery item is defective, Baumüller shall deliver an additional replacement or make a subsequent improvement at its own choice. Multiple subsequent improvements are permissible. Other warranty claims on the behalf of the purchaser, in particular also due to direct or indirect consequential damage are excluded. The precondition for any warranty is the normal contractual use of the delivery items. In the event of the utilisation of warranty services, the motor, the replacement part or the device has to be sent in free of freight charges, packaging costs or customs duties after prior co-ordination with Baumüller. Baumüller is exempted from any warranty if the party ordering returns the goods complained about without prior co-ordination or contrary to agreement. Warranty claims expire one month after rejection of a defect on which notice is given, in as far as the purchaser remains silent in this respect.

8. Notification of Defects

- a) The purchaser shall examine the subject matter of the contract and delivery items immediately and give notice of any defects without delay, however, no later than 7 days after receipt of the delivery. In case of non-obvious defects notice has to be given in writing without delay after their discovery, however, no later than 6 months from the point of delivery. In the event that the purchaser does not give notice of any defects in writing within this period of time, then the subject matter of the contract shall be considered as having been approved.
- b) The purchaser shall allow Baumüller a suitable inspection of defects of which notice is given and shall place all necessary/requested technical information, in particular, inspection records and test reports at Baumüller's disposal. In the event that the purchaser fails to do so, then the delivery items shall be considered as not having been complained about and as being approved. In the event that the purchaser alters the delivery items, then he/she shall lose his/her warranty claims.
- c) In the event of an established material defect or performance defect, Baumüller can eliminate the defect or supply a replacement. The purchaser can demand rescission or a reduction after the expiry of an appropriately set period of grace. Further claims on the behalf of the purchaser, in particular to the reimbursement of dismantling costs or installation costs are excluded. The same applies to damages which do not affect the delivery item itself.
- d) Natural wear and tear and damage which arises after the transferral of risk, in particular also due to incorrect or negligent handling, excessive demands or other unsuitable use not in conformity with the contract are excluded from

the warranty. The same applies in particular for defects which are attributable to atmospheric discharges, over-voltages and chemical influences.

- e) If no case of warranty is in existence or in the event that this subsequently turns out to be the case, the purchaser shall remunerate the utilisation or the use of an item or of a right, as well as services provided and expenses to an appropriate amount. Baumüller is entitled to a right of control as referred to in §§ 315 ff. BGB [German Civil Code].
- 9. Liability**
Contractual or legal claims on the behalf of the purchaser against Baumüller are limited to intent and gross negligence. This does not apply in as far as claims from the ProdHaftG [Product Liability Act] have been enforced. Baumüller shall only be held liable to the amount of the damage foreseeable in accordance with the purpose of the contract. Material damage which exceeds the value of a delivery/service is not foreseeable in this sense. The liability is limited in terms of amount to the remuneration contractually owed.
- 10. Payments**
- a) Invoices are payable at the time agreed in the contract, at the latest within 30 days after the invoice date, in cash and without deductions. The purchaser can only offset with claims which are final and absolute or undisputed. The same applies to the exercising of rights of retention.
- b) In the event of a delay in payment on the behalf of the purchaser, interest to the rate of 4 % above the respective minimum lending rate of the German Federal Bank, however at least 10 % has to be paid, without separate proof being required.
- c) Failure to comply with the terms of payment or circumstances which endanger the credit worthiness of the purchaser result in all claims immediately becoming due. In these cases, deliveries shall only be made against payment in advance.
- d) Cash payments, bank transfers or cheque and bill payments shall not be considered as payment/fulfilment of the obligation before the amount due for payment has been irrevocably received by Baumüller or credited to Baumüller's account.
- e) Payments have to be made directly to Baumüller. The field staff are not entitled to accept payments or to issue extensions or waivers without separate written authority.
- 11. Reservation of Ownership**
- a) The ownership of delivery items remains reserved up to the fulfilment of all existing claims against the purchaser from the business relation. Any bundling with other items shall be effected by the purchaser for Baumüller. Then, the entire product shall be considered as reserved goods.
- b) The purchaser is entitled to sell the reserved goods in orderly business transactions. All claims to which the purchaser is entitled from this sale or other legal grounds shall be assigned by him/her in advance to Baumüller. Baumüller shall accept the assignment. In the event that the reserved goods are bundled or sold with other items standing in the possession of third parties, then the assignment shall only apply to the amount of the invoice value of the reserved goods. The purchaser is authorised to collect these assigned claims. Upon request, he/she has to make notice of the assignment to the debtor.
- c) The purchaser shall inform Baumüller without delay of impending and enforced access on the behalf of third parties to the reserved goods or to the assigned claims. The purchaser shall bear the costs incurred by this.
- d) The authorisation on the behalf of the purchaser to dispose of the reserved goods and to collect assigned claims expires in the event that the terms of payment are not complied with, in particular, also in the case of bill and cheque protests. In this case, Baumüller is entitled to take possession of the reserved goods. The purchaser bears the costs incurred by this. The taking back of goods shall only represent a withdrawal from the contract when this is expressly stated.
- e) In the event that the value of the securities granted exceeds the secured claims in terms of amount by more than 20 %, then Baumüller shall renounce the securities exceeding this value.
- 12. Drawings and Documentation**
Baumüller is entitled to the exclusive property right and copyright to cost estimates, drawings and all other documentation. These documents may not be made accessible to third parties without prior written consent. In the event that a contract is not concluded, not implemented or otherwise ended, then all documents have to be returned immediately and unsolicited. There shall be no right to retention to these documents.
- 13. Copyright (in particular Software / Licence)**
- a) Baumüller is exclusively entitled to all rights to the software/edited versions, in particular property rights and copyrights to the relinquished software, in particular for the controlling of machines, systems and installations.
- b) Baumüller grants the purchaser/buyer the non-exclusive, non-transferable right to use the relinquished software in the framework of the contractual purpose at the contractually intended location/on the places in existence at the time of purchase (single licence). The software shall only be used on the associated purchased contractual item. Any use extending beyond this is prohibited. In the event of a use extending beyond this, Baumüller shall have the rights referred to in Items 13 c), 13 d).
- c) It is prohibited to make copies of the relinquished software, whether in whole or in part, in as far as the making of copies of the machine-readable material in the framework of the required data backup or as copies for internal company use has not separately been agreed upon with prior written consent from Baumüller. Processing of the relinquished software, in particular by means of alteration, translation or by bundling with other programs shall only be permitted after prior written consent from Baumüller. Protection notices from Baumüller on/in the software may not be removed and also have to be adopted onto copies and edited versions. Copies produced contrary to this condition shall come under the possession and copyright of Baumüller. Baumüller can prohibit the use of such copies and elect to demand the immediate surrender or complete destruction with proof of this destruction.
- d) The buyer is not permitted to extend the licence in terms of location/work places/machines/machine types or to grant rights of utilisation or grant sub-licences. The extension of the licence shall be permitted by Baumüller exclusively against a separate remuneration which has to be agreed upon in writing.
- 14. Applicable Law**
The law of the Federal Republic of Germany is authoritative for all rights and obligations from and in connection with this contract. The regulations of the UN Sales Convention (CISG) are excluded.
- 15. Place of Performance and Place of Jurisdiction**
The place of performance for delivery and payment is the seat of Baumüller. The place of jurisdiction for all dispu-

putes from and in connection with this contract, in particular also for cheque and bill liabilities is the seat of Baumüller.

16. Miscellaneous

In the event that individual or several conditions of these Conditions of Sale and Delivery should be or become ineffective in part or in whole, then the validity of the remaining conditions shall remain unaffected by this. The parties shall complement/replace the ineffective or incomplete condition with an appropriate regulation which most extensively corresponds to the economic purpose of the contractually desired regulation. The same applies for the case of the presence of a gap in the regulations.

For the case that acceptance and installation are also agreed upon, then the following conditions, Items 17 and 18 shall also apply:

17. Acceptance

- a) The inspection of the delivery items ready for acceptance shall take place in the Baumüller works. The purchaser shall bear the costs of this inspection. In the event that the purchaser fails to perform the inspection, then the delivery items shall be considered as having been delivered in conformity with the contract when they leave the works.
- b) The purchaser is obliged to take delivery of goods and services from Baumüller without delay. Immaterial defects do not entitle the purchaser to refuse the acceptance.
- c) In the event that the purchaser does not declare within 7 days after notification of the readiness for acceptance on the behalf of Baumüller or after receipt of the contractual service in writing and with exact, examinable specification of reasons that he/she refuses the acceptance, then the acceptance shall be considered as having been declared and the orderly performance of the contract as having been ascertained.
- d) The agreed service shall be considered as having been accepted when the item delivered has been put into operation by the purchaser himself/herself or upon his/her instructions by third parties beyond the functional test re-

quired to carry out the acceptance. This also applies in the event that the purchaser refuses the functional test/the acceptance without sufficient cause.

- e) Experts to be designated by both parties shall take part in the acceptance inspection. The result of the functional test shall be entered in a record to be signed by the purchaser in consideration of the technical specifications.

18. Erection and Installation

Erection and installation shall only be effected in the case of express agreement at the following further conditions:

- a) The purchaser makes required workers and material available at his/her own expense.
- b) Before the commencement of installation works the purchaser shall make available unsolicited all required specifications, in particular concerning the location of power lines which have been laid such that they are hidden and similar installations, as well as the required static specifications.
- c) Before the commencement of the erection/installation, the delivery items required for the commencement of works have to be on site and all preliminary works progressed to the extent that the erection/installation can immediately begin and be completely carried out without interruption.
- d) In the event that the erection, installation or putting into operation is delayed due to circumstances for which Baumüller is not responsible, then the purchaser shall bear the costs for idle time and journeys required on the behalf of the installation personnel.
- e) The installation personnel working time has to be certified weekly by the purchaser. The purchaser shall present to the installation personnel a written certification regarding the ending of the erection/installation without delay.
- f) Baumüller shall not be held liable for the installation personnel works, in as far as the works are not connected to the delivery and the erection or installation.
- g) Trial runs on systems not supplied by Baumüller shall not be carried out by the installation personnel.

9.3 Parameter List



NOTE

The description of the parameters for synchronous operation and positioning can be found in the technology module positioning and synchronous operation documentation, 5.96187

	Parameter	Default	Internal scaling	Page
-	P001 RFG output	-	$\pm 100,00\% = \pm 16383$ dec	170
X	P002 RFG input 1	0,00 %	$\pm 100,00\% = \pm 16383$ dec	169
X	P003 RFG ramp-up time 1	0,00 s	1,00 s = 100 dec	169
X	P004 RFG input 2	0,00 %	$\pm 100,00\% = \pm 16383$ dec	169
X	P005 RFG ramp-up time 2	0,00 s	1,00 s = 100 dec	169
X	P006 RFG input 3	0,00 %	$\pm 100,00\% = \pm 16383$ dec	169
X	P007 RFG ramp-up time 3	0,00 s	1,00 s = 100 dec	169
X	P009 RFG time halt	0,00 s	1,00 s = 100 dec	170
X	P010 RFG ramp-down time 1	0,00 s	1,00 s = 100 dec	170
X	P011 RFG ramp-down time 2	0,00 s	1,00 s = 100 dec	170
X	P012 RFG ramp-down time 3	0,00 s	1,00 s = 100 dec	170
X	P013 RFG mode	0001	1:1	169
-	P014 RFG state	-	1:1	168
X	P016 RFG rounding	0 s	1000 ms = 1000 dec	170
-	P017 OL Index	0	1:1	225
-	P018 OL Value	-	1:1	225
X	P019 EM maximum speed	3000 rpm	1:1	100
X	P020 E1 shift factor	0	1:1	115
-	P021 E1 position actual value 16	-	1:1	115
-	P022 E1 phi actual value	-	1:1	114
-	P023 E1 N actual value	-	$\pm 100,00\% = \pm 16384$ dec	113
X	P024 E1 no. of graduation marks	512 Inc	1:1	112
-	P025 E1 state	-	1:1	110
-	P026 E1 revolutions	1	1:1	113
-	P030 Mot phi mechanical	-	$360,0^\circ = 3600$ dec	95
X	P031 Mot mode	0-	1:1	93
-	P032 Mot rho electrical	-	$360,0^\circ = 3600$ dec	95
X	P033 Mot no. of pole pairs	3	1:1	94
X	P034 Mot rotating field	1	1:1	94
X	P035 Mot locating angle	$240,0^\circ$	$360,0^\circ = 3600$ dec	94
-	P036 Mot state	-	1:1	92
X	P037 Mot delta l	5	1:1	94
X	P038 N M limiter mode	0	1:1	127
X	P039 Mot delta rho	5	1:1	94
X	P040 E1 mode	0000	1:1	111
-	P041 E1 delta phi 16	0000 Inc	1:1	116

X: Parameter is saved in the data record

	Parameter	Default	Internal scaling	Page
-	P042 E1 delta phi 32	0000 0000	1:1	116
-	P043 E1 Rev actual value	-	1:1	113
-	P044 E1 sine measured value	-	±1,000 = ±32752 dec	116
-	P045 E1 cosine measured value	-	±1,000 = ±32752 dec	116
X	P046 E1 overspeed	115,00 %	+100,00 % = +16384 dec	117
X	P047 N additional set value	0,00 %	±100,00 % = ±16384 dec	127
X	P048 I M additional set value	0,00 %	±100,00 % = ±16384 dec	123
X	P049 N J compensation	0	1:1	127
-	P050 N set value	-	±100,00 % = ±16384 dec	127
-	P051 N actual value	-	±100,00 % = ±16384 dec	127
-	P052 N controller output	-	±100,00 % = ±16384 dec	127
X	P053 N M limiter bipolar	100,00 %	±100,00 % = ±16384 dec	128
X	P054 N M limiter Mot/TD1	100,00 %	100,00 % = 16384 dec	128
X	P055 N M limiter Gen/TD2	100,00 %	100,00 % = 16384 dec	128
X	P056 N block time	60,0 s	60,0 s = 600 dec	128
X	P057 N P gain	10,0	10,0 = 100 dec	126
X	P058 N integral action time	25,0 ms	25,0 ms = 250 dec	127
-	P059 N state	-	1:1	126
-	P060 N deviation	-	±100,00 % = ±16384 dec	128
X	P061 N limiter deviation	99,99 %	100,00 % = 16384 dec	128
X	P062 E1 N smoothing actual value	1,0 ms	10,0 ms = 100 dec	113
-	P065 TM mode	0	1:1	130
-	P066 TM M loading	-	±100,00 % = ±16384 dec	132
X	P067 I M set value	0,00 %	±100,00 % = ±16384 dec	122
-	P068 I Iq controller output	-	±100,00 % = ±16384 dec	123
-	P069 I EMC set value	-	±100,00 % = ±16384 dec	123
-	P070 I phase voltage U	-	±100,00 % = ±16384 dec	124
-	P071 I Id set value	-	±100,00 % = ±16384 dec	123
-	P072 I Id actual value	-	±100,00 % = ±16384 dec	123
-	P073 I phase current U	-	±100,00 % = ±10922 dec	124
-	P074 I phase current V	-	±100,00 % = ±10922 dec	124
-	P075 I Uq-Sollwert	-	±100,00 % = ±16384 dec	123
-	P076 I Ud set value	-	±100,00 % = ±16384 dec	124
-	P077 I Id set value	-	±100,00 % = ±16384 dec	124
-	P078 I Id actual value	-	±100,00 % = ±16384 dec	124
-	P079 I state	-	1:1	121
X	P080 I P gain	1,0	10,0 = 100 dec	121
X	P081 I integral action time	2,5 ms	1000,0 ms = 10000 dec	121
-	P083 I current offset U	-	±25,00 % = ±8188 dec	124
-	P084 I current offset V	-	±25,00 % = ±8188 dec	124
-	P086 I phase voltage V	-	±100,00 % = ±16384 dec	124
X	P087 PS Uzk nominal	540 V	1:1	67
X	P088 I2t warning limit motor	100,00 %	100,00 = 10000 dec	88
X	P089 I2t time constant motor	0	60 s = 60 dec	88
X	P090 PU mode	0000	1:1	70
-	P091 I2t value motor	-	100,00 % = 10000 dec	88

X: Parameter is saved in the data record

	Parameter	Default	Internal scaling	Page
-	P092 TM Mact / Mn	-	±100,00 % = ±16384 dec	132
-	P093 I2t state	-	1:1	88
X	P094 TM M > M2	90,00 %	100,00 % = 16384 dec	131
X	P095 TM time 2	0,000 s	1,000 s = 1000 dec	131
X	P096 TM M > M1	90,00 %	100,00 % = 16384 dec	131
X	P097 TM time 1	0,000 s	1,000 s = 1000 dec	131
-	P098 TM state	-	1:1	130
-	P099 I current actual value	-	±100,00 % = ±16384 dec	124
-	P100 PWM phase U	-	±100,00 % = ±16384 dec	78
-	P101 PWM phase V	-	±100,00 % = ±16384 dec	78
-	P102 PWM phase W	-	±100,00 % = ±16384 dec	78
X	P103 PWM frequency	8,0 kHz	8,0 kHz = 80 dec	79
X	P104 E2 N=0 threshold	1,00 %	100,00 % = +16384 dec	117
X	P105 E2 N>Nx ON threshold	100,00 %	100,00 % = +16384 dec	117
X	P106 E2 N>Nx OFF threshold	95,00 %	100,00 % = + 16384 dec	117
X	P107 E1 N=0 threshold	1,00 %	100,00 % = +16384 dec	117
X	P108 E1 N>Nx ON threshold	100,00 %	100,00 % = +16384	117
X	P109 E1 N>Nx OFF threshold	96,00 %	100,00 = +16384 dec	117
-	P110 PS state	-	1:1	67
-	P111 PS voltage Uzk	-	560V = 560 dec	67
X	P112 PS voltage failure time	3,000 s	3,000 s = 3000 dec	68
-	P113 PU I max	-	100,0 A = 1000 dez	72
-	P114 PU I nominal	-	100,0 A = 1000 dec	72
-	P115 PU state	-	1:1	69
X	P116 PU I limit	2,5 A	100,0 A = 1000 dec	73
-	P117 PU type	-	1:1	71
-	P118 PU temperature	-	80° C = 80 dec	73
X	P119 PU overload time	-	10,00 S = 1000 dec	72
-	P120 M control word	-	1:1	148
-	P121 M state word	-	1:1	150
X	P122 M desired operation mode	-3	1:1	152
-	P123 M actual operation mode	-	1:1	152
-	P124 M error code	-	1:1	153
-	P125 M error index	-	1:1	153
X	P126 M communication source	0000	1:1	154
X	P127 M communication monitoring	0000	1:1	155
X	P128 M monitoring time	0 ms	1000 ms = 1000 dec	155
X	P129 M monitoring code	0	1:1	155
X	P130 M HALT code	1	1:1	155
X	P131 M RAPID HALT code	2	1:1	156
X	P132 M INHIBIT code	3	1:1	156
X	P133 M SHUTDOWN code	3	1:1	156
X	P134 M state bit no. 14	0000	1:1	156
X	P135 M state bit no. 15	0000	1:1	156
X	P136 M mode	0001	1:1	153
-	P137 M state 1	-	1:1	153
X: Parameter is saved in the data record				

	Parameter	Default	Internal scaling	Page
-	P138 Language	1	1:1	164
-	P139 PU lxt value	-	±100,00 % = ±16384 dec	75
X	P140 SVG target Pxxx	0	1:1	172
-	P141 SVG output value	-	±100,00 % = ±10000 dec	172
X	P142 SVG set value 1	100,00 %	±100,00 % = ±10000 dec	172
X	P143 SVG set value 2	0,00 %	±100,00 % = ±10000 dec	172
X	P144 SVG set value 3	-100,00 %	±100,00 % = ±10000 dec	172
X	P145 SVG set value 4	0,00 %	±100,00 % = ±10000 dec	172
X	P146 SVG time 1	1,000 s	1,000 s = 1000 dec	172
X	P147 SVG time 2	1,000 s	1,000 s = 1000 dec	172
X	P148 SVG time 3	1,000 s	1,000 s = 1000 dec	172
X	P149 SVG time 4	1,000 s	1,000 s = 1000 dec	172
-	P150 SVG state	-	1:1	172
-	P151 MT state	-	1:1	89
X	P152 MT mode	0000	1:1	90
-	P153 MT temperature	-	100° C = 100 dec	90
X	P154 MT threshold 1	125° C	100° C = 100 dec	90
X	P155 MT threshold 2	125° C	100° C = 100 dec	90
X	P156 MT shutdown threshold	150° C	100° C = 100 dec	90
X	P157 MT hysteresis	5° C	100° C = 100 dec	90
X	P159 OS sync. tolerance	0,2 µs	50,0 µs = 500 dec	165
-	P160 OS selection	-	1:1	166
-	P161 OS sampling time	-	250,0 µs = 2500 dec	165
-	P162 OS message	-	1:1	165
-	P163 OS BUS6-VC SW release	-	e.g. 3.08 = 308 dec	165
X	P166 OS state	-	1:1	164
X	P167 OS sync. slot	0 µs	1000 µs = 1000 dec	165
X	P168 OS sync. offset	1 µs	1000 µs = 1000 dec	165
-	P169 OS value	-	1:1	166
-	P170 SI state	-	1:1	206
-	P171 SI baud rate	9600 Baud	1:1	207
X	P172 SI mode	0003	1:1	207
-	P173 SI array state	-	1:1	207
-	P174 OS user SW	-	1:1	165
-	P175 BAPS WD state	-	1:1	222
-	P176 BAPS C master command	-	1:1	222
-	P177 BAPS C slave acknowledgement	-	1:1	223
-	P178 BAPS C state	-	1:1	223
-	P180 USS® state	-	1:1	218
X	P181 USS® mode	0000	1:1	218
X	P182 USS® baud rate	9600 Baud	9600 Baud = 9600 dec	220
X	P183 USS® PIV number	3 words	1:1	220
X	P184 USS® PD number	2 words	1:1	220
X	P185 USS® set value Pxxx	0	1:1	221
X	P186 USS® actual value Pxxx	0	1:1	221
X	P188 M error reaction time	0,00 s	1,00 s = 100 dec	157

X: Parameter is saved in the data record

	Parameter	Default	Internal scaling	Page
X	P189 M error reaction code	0	1:1	157
-	P190 DSM command	-	1:1	161
-	P191 DSM state	-	1:1	161
-	P192 DSM message	-	1:1	161
-	P193 DSM DS name	-	1:1	162
-	P194 DSM DS article no.	-	1:1	162
-	P195 DSM message Pxxx	-	1:1	162
-	P196 DSM load data set	-	1:1	162
-	P197 DSM DS program cycles	-	1:1	162
-	P198 DSM key	-	1:1	163
X	P199 PWM mode switch	100 %	1:1	79
-	P200 P state	-	1:1	134
X	P201 P mode	0000	1:1	134
X	P202 P Kv factor	10 1/s	1:1	134
X	P203 P deviation limiter dynamic	0000 0800 Inc	1:1	137
X	P204 P N limiter bipolar	100,00 %	100,00 % = 16384 dec	136
-	P205 P rev set value	-	1:1	136
-	P206 P phi set value	-	1:1	136
X	P207 P N precontrol	100,00 %	100,00 % = 16384 dec	135
-	P208 P set value	-	1:1	135
-	P209 P actual value	-	1:1	135
-	P210 P deviation	-	1:1	136
-	P211 P controller output	-	±100,00 % = ±16384 dec	135
X	P212 P deviation limiter static	0000 0100 Inc	1:1	136
X	P213 P N precontrol smoothing	1,0 ms	50,0 ms = 500 dec	135
X	P214 P time	1,000 s	1,000 s = 1000 dec	137
X	P216 L Getriebe Faktor	1,0	1,0 = 10 dez	138
-	P217 P deviation Phi	-	1:1	138
-	P218 P rev actual value	-	1:1	136
-	P219 P phi actual value	-	1:1	136
X	P220 P N precontrol output	-	±100,00 % = ±16384 dec	135
-	P221 EM measuring-command	0	1:1	104
-	P222 EM measuring-state	0	1:1	105
-	P223 EM measured val phi 1	0000 0000 Inc	1:1	105
-	P224 EM Kp	10,0	10,0 = 100 dec	101
-	P225 EM state	-	1:1	96
X	P226 EM mode	0001	1:1	98
X	P227 EM no. of graduation marks	1024	1:1	100
-	P228 EM encoder types	-	1:1	97
X	P229 EM offset zero impulse	0000 Inc	1:1	100
-	P230 E2 sine measured value	-	±1,0000 = ±32752 dec	116
-	P231 E2 cosine measured value	-	±1,0000 = ±32752 dec	116
-	P232 E2 revolutions	1	1:1	113
-	P233 EM measured val rev 1	0000 0000 Inc	1:1	106
-	P234 EM measured val phi 2	0000 0000 Inc	1:1	105
-	P235 EM measured val rev 2	0000 0000 Inc	1:1	106
X: Parameter is saved in the data record				

	Parameter	Default	Internal scaling	Page
-	P236 E2 shift factor	0	1:1	115
-	P237 E2 position actual value 16	-	1:1	115
X	P238 E2 N smoothing actual value	1,0 ms	10,0 ms = 100 dec	113
X	P239 E2 overspeed	115,00 %	±100,00 % = ±16384 dec	117
-	P240 E2 state	-	1:1	110
X	P241 E2 mode	0000	1:1	111
X	P242 E2 no. of graduation marks	512 Inc	1:1	112
-	P243 E2 N actual value	-	±100,00 % = ±16384 dec	113
-	P244 E2 phi actual value	-	1:1	114
-	P247 E2 delta phi 16	0000 Inc	1:1	116
-	P248 E2 delta phi 32	0000 0000	1:1	116
-	P249 E2 Rev actual value	-	1:1	113
X	P260 MM magnetizing current Id	0,0 A	10,0 A = 100 dec	81
X	P261 MM motor nominal current	2,5 A	10,0 A = 100 dec	81
X	P262 MM nominal speed	1500 rpm	1:1	83
X	P263 MM nominal frequency	52,6 Hz	50,0 Hz = 500 dec	83
X	P264 MM Kp flow controller	1,0	15,0 = 150 dec	81
X	P265 MM Tn flow controller	30,0 ms	1000,0 ms = 10000 dec	81
-	P266 MM flux set value	-	+100,00 % = +16384 dec	83
-	P267 MM flux actual value	-	+100,00 % = +16384 dec	83
X	P268 MM Ke factor	0V/1000	1:1	82
X	P269 MM mode	0	1:1	82
X	P270 EA mode	0	1:1	173
X	P271 EA motor potentiometer +	0	1:1	173
X	P272 EA motor potentiometer -	0	1:1	173
X	P272 EA Motorpoti -	0	1:1	175
X	P273 EA motor potentiometer Pxxx	0	1:1	174
X	P274 EA motor potentiometer dynamics	1	1:1	174
X	P275 EA motor potentiometer increment	1,00 %	±100,00 % = ±10000 dec	174
-	P276 EA motor potentiometer value	-	±100,00 % = ±16384 dec	174
X	P277 AI 1 input channel	0	1:1	179
X	P278 AI 1 smoothing	1 ms	1:1	179
X	P279 AI 1 scaling	1,00	±2,00 % = ±200 dec	179
X	P280 AI 1 target Pxxx	0	1:1	179
X	P281 AI 1 offset	0,00 %	±100,00 % = ±10000 dec	179
X	P282 AI 1 threshold value	0,00 %	+100,00 % = +10000 dec	180
-	P283 AI 1 value	-	±100,00 % = ±10000 dec	180
X	P284 AI 2 input channel	1	1:1	179
X	P285 AI 2 smoothing	1 ms	1:1	179
X	P286 AI 2 scaling	1,00	±2,00 % = ±200 dec	179
X	P287 AI 2 target Pxxx	0	1:1	179
X	P288 AI 2 offset	0,00 %	±100,00 % = ±10000 dec	179
X	P289 AI 2 threshold value	0,00 %	±100,00 % = ±10000 dec	180
-	P290 AI 2 value	-	±100,00 % = ±10000 dec	180
X	P291 MM MGen1 Nnominal	95 %	1:1	85
X	P292 MM MGen2 12000 rpm 12000 U/min	30 %	1:1	85

X: Parameter is saved in the data record

	Parameter	Default	Internal scaling	Page
-	P293 MM Tr actual value	-	1000 ms = 1000 dec	83
X	P294 MM frequency temperature 1	10,0 Hz	10,0 Hz = 100 dec	84
X	P295 MM nominal frequency at temperature 1	20° C	20° C = 20 dec	84
X	P296 MM nominal frequency at temperature 2	80° C	80° C = 80 dec	84
-	P297 MM frequency = f (temp)	-	50,00 Hz = 5000 dec	84
X	P298 MM stator resistance	0 Ohm	1:1	83
X	P299 MM leakage inductance	0 mH	1:1	83
X	P302 AI state	-	1:1	178
X	P303 MM Kp field weakening	1,0	15,0 = 150 dez	85
X	P304 MM Tn field weakening	30,0 ms	1000,0 ms = 10000 dez	85
X	P330 AO 1 source Pxxx	0	1:1	183
X	P331 AO 1 offset	0 Dig	1:1	183
X	P332 AO 1 scaling	1 Dig/V	1:1	183
X	P334 AO 2 source Pxxx	0	1:1	183
X	P335 AO 2 offset	0	1:1	183
X	P336 AO 2 scaling	1 Dig/V	1:1	183
X	P337 AO test value	0,000 V	1:1	183
-	P338 AO state	-	1:1	183
X	P342 DI 4 target Pxxx	120	1:1	190
X	P343 DI 4 bit selection	0008	1:1	190
X	P344 DI 4 LOW pattern	0000	1:1	190
X	P345 DI 4 HIGH pattern	0008	1:1	190
X	P350 LED 1 source Pxxx	0	1:1	186
X	P351 LED 1 bit selection	0	1:1	186
X	P352 LED 1 bit pattern	0	1:1	186
X	P353 LED 2 source Pxxx	0	1:1	186
X	P354 LED 2 bit selection	0	1:1	186
X	P355 LED 2 bit pattern	0	1:1	186
X	P356 LED 3 source Pxxx	0	1:1	186
X	P357 LED 3 bit selection	0	1:1	186
X	P358 LED 3 bit pattern	0	1:1	186
X	P359 LED 4 source Pxxx	0	1:1	186
X	P360 LED 4 bit selection	0	1:1	186
X	P361 LED 4 bit pattern	0	1:1	186
-	P362 LED state	-	1:1	186
X	P370 DI 1 target Pxxx	0	1:1	190
X	P371 DI 1 bit selection	0	1:1	190
X	P372 DI 1 LOW pattern	0	1:1	190
X	P373 DI 1 HIGH pattern	0	1:1	190
X	P374 DI 2 target Pxxx	0	1:1	190
X	P375 DI 2 bit selection	0	1:1	190
X	P376 DI 2 LOW pattern	0	1:1	190
X	P377 DI 2 HIGH pattern	0	1:1	190
X	P378 DI 3 target Pxxx	120	1:1	190
X	P379 DI 3 bit selection	0800	1:1	190
X	P380 DI 3 LOW pattern	0000	1:1	190

X: Parameter is saved in the data record

	Parameter	Default	Internal scaling	Page
X	P381 DI 3 HIGH pattern	0080	1:1	190
-	P382 DI state	-	1:1	189
X	P383 DO 1 source Pxxx	0	1:1	192
X	P384 DO 1 bit selection	0	1:1	192
X	P385 DO 1 bit pattern	0	1:1	193
X	P386 DO 2 source Pxxx	0	1:1	192
X	P387 DO 2 bit selection	0	1:1	192
X	P388 DO 2 bit pattern	0	1:1	193
X	P389 DO 3 source Pxxx	0	1:1	192
X	P390 DO 3 bit selection	0	1:1	192
X	P391 DO 3 bit pattern	0	1:1	193
X	P392 DO state	-	1:1	193
-	P450 GP status	-	1:1	200
X	P451 GP Info 1	0	1:1	201
X	P452 GP Info 2	0	1:1	201
X	P452 GP Info 2	0	1:1	201
X	P453 GP Info 3	0	1:1	201
X	P453 GP Info 3	0	1:1	201
X	P454 GP Info 4	0	1:1	201
X	P455 GP Info 5	0	1:1	201
X	P456 GP Info 6	0	1:1	201
X	P457 GP Info 7	0	1:1	201
X	P458 GP Info 8	0	1:1	201
X	P459 GP Info 9	0	1:1	201
X	P460 GP Info 10	0	1:1	201
X	P461 GP Info 11	0	1:1	201
X	P462 GP Info 12	0	1:1	201
X	P463 GP Info 13	0	1:1	201
X	P464 GP Info 14	0	1:1	201
X	P465 GP Info 15	0	1:1	201
X	P466 GP Info 16	0	1:1	201
-	P467 GP Latch	0	1:1	202
-	P467 GP Latch	0	1:1	202
-	P500 XDI state	-	1:1	195
X	P501 XDI 1 target Pxxx	0	1:1	195
X	P502 XDI 1 bit selection	0	1:1	196
X	P503 XDI 1 LOW pattern	0	1:1	196
X	P504 XDI 1 HIGH pattern	0	1:1	196
X	P505 XDI 2 target Pxxx	0	1:1	195
X	P506 XDI 2 bit selection	0	1:1	196
X	P507 XDI 2 LOW pattern	0	1:1	196
X	P508 XDI 2 HIGH pattern	0	1:1	196
X	P509 XDI 3 target Pxxx	0	1:1	195
X	P510 XDI 3 bit selection	0	1:1	196
X	P511 XDI 3 LOW pattern	0	1:1	196
X	P512 XDI 3 HIGH pattern	0	1:1	196
X: Parameter is saved in the data record				

	Parameter	Default	Internal scaling	Page
X	P513 XDI 4 target Pxxx	0	1:1	195
X	P514 XDI 4 bit selection	0	1:1	196
X	P515 XDI 4 LOW pattern	0	1:1	196
X	P516 XDI 4 HIGH pattern	0	1:1	196
X	P517 XDI 5 target Pxxx	0	1:1	195
X	P518 XDI 5 bit selection	0	1:1	196
X	P519 XDI 5 LOW pattern	0	1:1	196
X	P520 XDI 5 HIGH pattern	0	1:1	196
X	P521 XDI 6 target Pxxx	0	1:1	195
X	P522 XDI 6 bit selection	0	1:1	196
X	P523 XDI 6 LOW pattern	0	1:1	196
X	P524 XDI 6 HIGH pattern	0	1:1	196
X	P525 XDI 7 target Pxxx	0	1:1	195
-	P526 XDI 7 bit selection	0	1:1	196
X	P527 XDI 7 LOW pattern	0	1:1	196
X	P528 XDI 7 HIGH pattern	0	1:1	196
X	P529 XDI 8 target Pxxx	0	1:1	195
X	P530 XDI 8 bit selection	0	1:1	196
X	P531 XDI 8 LOW pattern	0	1:1	196
X	P532 XDI 8 HIGH pattern	0	1:1	196
-	P533 XDO state	-	1:1	198
X	P535 XDO 1 source Pxxx	0	1:1	198
X	P536 XDO 1 bit selection	0	1:1	198
X	P537 XDO 1 bit pattern	0	1:1	199
X	P538 XDO 2 source Pxxx	0	1:1	198
X	P539 XDO 2 bit selection	0	1:1	198
X	P540 XDO 2 bit pattern	0	1:1	199
X	P541 XDO 3 source Pxxx	0	1:1	198
X	P542 XDO 3 bit selection	0	1:1	198
X	P543 XDO 3 bit pattern	0	1:1	199
X	P544 XDO 4 source Pxxx	0	1:1	198
X	P545 XDO 4 bit selection	0	1:1	198
X	P546 XDO 4 bit pattern	0	1:1	199
X	P547 XDO 5 source Pxxx	0	1:1	198
X	P548 XDO 5 bit selection	0	1:1	198
X	P549 XDO 5 bit pattern	0	1:1	199
X	P550 XDO 6 source Pxxx	0	1:1	198
X	P551 XDO 6 bit selection	0	1:1	198
X	P552 XDO 6 bit pattern	0	1:1	199
X	P553 XDO 7 source Pxxx	0	1:1	198
X	P554 XDO 7 bit selection	0	1:1	198
X	P555 XDO 7 bit pattern	0	1:1	199
X	P556 XDO 8 source Pxxx	0	1:1	198
X	P557 XDO 8 bit selection	0	1:1	198
X	P558 XDO 8 bit pattern	0	1:1	199
X	P562 TM correction factor 1	1,0000	1:1	132
X: Parameter is saved in the data record				

	Parameter	Default	Internal scaling	Page
X	P563 TM correction factor 2	1,0000	1:1	132
X	P564 TM correction factor 2	0,00 %	+100,00 % = +16384 dez	132
-	P567 EA state	-	1:1	175
X	P568 EA ramp-up final value	100,00 %	±100,00 % = ±16384 dez	175
X	P569 EA ramp-down final value	100,00 %	±100,00 % = ±16384 dez	176
X	P570 G1 sine ² upper limit	95%	±100,00 % = ±16384 dez	119
X	P571 G2 sine ² upper limit	95%	±100,00 % = ±16384 dez	119
X	P572 GM field angle monitoring threshold	20%	±100,00 % = ±16384 dez	119
-	P576 I NF center frequency	0,000 kHz	1,000 kHz = 1000 dez	124
-	P576 I NF Sperrfrequenz	0,000 kHz	1,000 kHz = 1000 dez	124
-	P577 I NF bandwidth	0,100 kHz	1,000 kHz = 1000 dez	124
X: Parameter is saved in the data record				

9.4 Index

A

Accessories	35
Accuracy	11
Additional Parameter	224
Analog Inputs	177
Analog Outputs	182
Analog/Digital Interface	30
Appendix	237
Assembly	17
Assembly Note	18
Asynchronous Serial Interface	27

B

BAPS Communication	222
Boot data record	56

C

Closed-Loop Control	12
Commands to Start the Drive	58
Commands to Stop the Drive	60
Commissioning	37
Connection Cable	31
Connection Cable RS485	34
Connection voltage	107
Connector Pin Assignment	25
Control Word	148
Current Controller	120
Current Measurement and Monitoring	66
Current measurement and monitoring	66

D

Danger Information	19
Data Set Management	158
Deviation monitoring	136
Digital Inputs	187
Digital Outputs	191
Dimensions	17
Display	21
Disposal	236
Drive Manager	140

E

Electrical Data	11
Encoder Evaluation	63
Encoder Manager	96
Encoder type	97
Evaluation Encoder	108
External Digital input	194
External Digital Outputs	197

F

Field Angle Calculation	92
Function diagrams	63

G

General Conditions of Sale and Delivery	238
---	-----

I

Incremental Encoder Emulation	26
Initial Commissioning	40
Inputs	10
Installation	19
Interfaces	11

L

LED Display	184
LED Display Element	22
Locating Position Reference Point Setting	57

M

Maintenance	227
Maintenance information	227
Manufacturer Declaration	237
Motor Model	80
Motor Overload Monitoring	86
Motor Potentiometer	173
Motor Temperature	29
Motor Temperature Monitoring	89

N

Number of Pole Pairs	92
----------------------	----

O

Operation Software	10
Operation system	164
Optional Boards	10
Outputs	10
Overload Monitoring of Power Unit	75
Overview V-Controller	64

P

P302	178
PC Connection	32
Position Controller	133
Power consumption	11
Power Supply	67
Power Unit	69
Pulse Width Modulation	78

R

Ramp Function Generator	167
Rectangle Incremental Encoder	28
Resolver	27
RS232 Interface	25
RS485 Interface	25

S

Sampling Rate	11
Serial Connection Cable	32
Service Interface	203
Set Value Generator	171
Seven-segment Display	21
Sine Encoder	29
Sine Incremental Encoder 5V	28
Speed Controller	126
State Word	150

T

Technical Data	9
Terminal Diagram	23
Terminal Ring Circuit	33
Torque Monitoring	129
Transportation	15
Transportation damage	15
Type Code	12

U

Unit Control State Machine	142
Unit Control State Transition	145
Unpacking	15

USS® Protocol 208

V

Version 12
Voltage range 11

be in motion

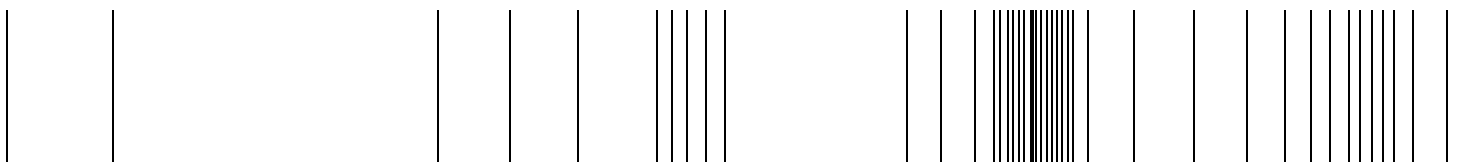

Baumüller Nürnberg GmbH Ostendstraße 80-90 90482 Nürnberg T: +49(0)911-5432-0 F: +49(0)911-5432-130 www.baumueller.de

All information given in this manual is customer information, subject to change without notice. We reserve the right to further develop and actualize our products continuously using our permanent revision service. Please notice, that specifications/data/information are current values according to the printing date. These statements are not legally binding according to the measurement, computation and calculations. Before you make any information given in this manual to the basis of your own calculations and/or applications, please make sure that you have the latest edition of the information in hand. No liability can be accepted concerning the correctness of the information.