

FEATURES

- Optimised for combustible gases and vapours
- Thermal conductivity versions available
- Certified flameproof component
- Integral pellistors
- Low power
- Standard miniature body size
- Poison resistant - silicones and hydrogen sulfide
- Shock resistant
- ATEX certified Ex II 2G Ex d IIC Gb ($T_a = -40$ to $+55$ °C)
- ATEX certified Ex I M2 Ex d I Mb ($T_a = -40$ to $+55$ °C)
- IECEx certified Ex d IIC Gb ($T_a = -40$ to $+55$ °C)
- IECEx certified Ex d I Mb ($T_a = -40$ to $+55$ °C)
- CSA certified - File 107498
- UL recognised - File E186043

DESCRIPTION

The VQ500 Series is a complete range of miniature, fully certified, flameproof sensor heads containing a high quality, low power pellistor pair optimised for the detection of combustible gases or % volume gases in thermal conductivity mode. They have an outline identical to modern miniature electrochemical cells and are ideally suited for use in portable instruments.

Within the VQ500 Series there are specific sensors that are able to detect most combustible gases/vapours and ammonia at LEL levels. The thermal conductivity version will detect most % volume gases that have thermal conductivities different from that of air.

GENERAL PARAMETERS

All tests are carried out at ambient temperature, humidity and pressure at a flow rate of 0.5 l/min within manufacturer's test equipment.

Linearity:

combustible sensors	linear up to 3% vol. methane/balance air
thermal conductivity	consult manufacturer
Operation, storage and shipping in packaging (pots):		
temperature	-40 to +55 °C
humidity	0 to 80% RH non-condensing
Response time at T_{50} (see note)	<10 seconds
Drift:		
long-term signal drift	<5% LEL/month
long-term zero drift	<5% LEL/month



NOTES

1. Response and drift measured with 1% methane in the manufacturer's test equipment.
2. The response to flammable vapours, especially heavy aromatic compounds, may be different to the theoretical figures (k factors) listed in Pellistor Application Note 3. These k factors are for guidance only and ideally the sensors should be calibrated to the actual vapour concentration required.

DESIGN CONSIDERATIONS

- a) The polarity of the supply voltage may be reversed without causing damage. The only effect is to reverse the polarity of the output signal.
- b) The sensitivity is measured in the standard manufacturer's test jig with no filter or other material between the gas and the sinter.
- c) The calibration of the sensor should be checked if it has been exposed, whilst operating, to gas concentrations greater than the Lower Explosive Limit. Exceeding this limit may permanently damage the sensor.
- d) It is recommended that the sensors are run in a Wheatstone bridge circuit (see Fig. 1).
- e) It is not recommended to direct the gas flow onto the sinter.
- f) It is recommended that the sensors are operated in constant voltage mode, although it is possible to run the sensors in constant current mode.

For further information or application support, contact SGX Sensortech.

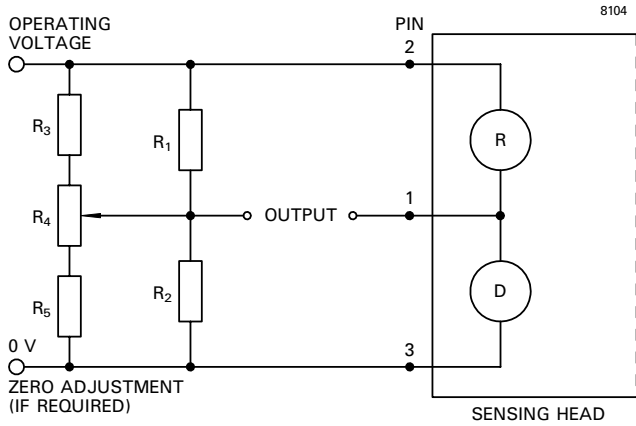

$$R_1 = R_2 = 500 - 2000 \Omega,$$

$$R_3 = R_5 \approx 10R_1, R_4 \approx 20R_1$$

Fig. 1 Recommended bridge circuit

WARRANTY PERIOD

12 months from date of despatch. Extended warranties are available on request.

CERTIFICATIONS

The VQ500 Series is certified as a flameproof component to EN60079-0:2006 (including amendments A1 and A2) and EN60079-1:2007 by SIRA Certification Services (SCS), England. The certificate number is SIRA 01ATEX1073U. Instructions specific to hazardous area installations are detailed below.

The Canadian Standards Association has issued a component certification for the VQ500 Series for use as part of an intrinsically safe portable combustible gas detector or housed in a remote sensor housing. It has satisfied the requirements of CSA standard C22.2 No. 30-M 1986 and UL standard 1203 as a flame arrester for Class 1, Groups A, B, C and D.

Underwriters Laboratories Inc. recognise the VQ500 Series as components in intrinsically safe single- or multi-gas detectors for use in Class 1, Division 1, Groups A, B, C and D hazardous locations. It has satisfied the requirements of UL913, fifth edition.

INSTRUCTIONS

Instructions specific to hazardous area installations (reference European ATEX Directive 94/9/EC, Annex II, 1.0.6).

The following instructions apply to equipment covered by certificate number SIRA 01ATEX1073U.

1. The VQ500 Series Gas Sensing Head is component-approved only and may not be used as a stand-alone item in a hazardous area without further protection.
2. The component is only certified for operation in ambient temperatures between -40 and $+55$ °C and should not be used outside this range.
3. The VQ500 Series Gas Sensing Head shall be used in conjunction with apparatus providing an intrinsically safe supply having a maximum output power (P_O) not greater than 2.5 W.
4. For the purpose of temperature classification of the apparatus in which the VQ500 Series Gas Sensing Head is used, the maximum temperature rise on any external surface does not exceed 64 °C.
5. The VQ500 Series Gas Sensing Head has not been assessed as a safety device (EHSR 1.5).
6. There are no user-serviceable parts in the component.
7. The end-user/installer should be aware that the certification of the VQ500 Series Gas Sensing Head relies on the following materials used in its construction, which are suitable for most common applications:

Enclosure	Stainless Steel
Sinter	Stainless Steel
Bushing	Epoxy resin
8. The certification markings for the VQ500 Series Gas Sensing Head are:

Ex II 2G Ex d IIC Gb and Ex IM 2 Ex d I Mb