

Up to PL e of EN ISO 13849-1 PNOZ s7.2



Contact expansion module for increasing the number of available contacts

Approvals

	PNOZ s7.2
	◆
	◆
	◆

Unit features

- ▶ Positive-guided relay outputs:
 - 4 safety contacts (N/O), instantaneous
 - 1 auxiliary contact (N/C), instantaneous
- ▶ Safe separation of safety contacts 13-14, 23-24, 33-34 from all other circuits
- ▶ Connection options for expansion modules
- ▶ LED for:
 - Input status, channel 1
 - Input status, channel 2
 - Switch status of the safety contacts
- ▶ Plug-in connection terminals (either spring-loaded terminals or screw terminals)

Unit description

The unit meets the requirements of EN 60947-5-1, EN 60204-1 and VDE 0113-1. The contact expander module is used to increase the number of instantaneous safety contacts available on a base unit. The category that can be achieved in accordance with EN 954-1 and EN ISO 13849-1 depends on the category of the base

unit. The contact expander module may not exceed this.

Safety features

The unit meets the following safety requirements:

- ▶ The contact expansion module expands an existing circuit. As the output relays are monitored via the base unit's feedback loop, the safety functions on the existing circuit are transferred to the contact expansion module.
- ▶ The safety function remains effective in the case of a component failure.
- ▶ Earth fault in the feedback loop: Detected, depending on the base unit that is used.
- ▶ Earth fault in the input circuit: The output relays de-energise and the safety contacts open.

Block diagram

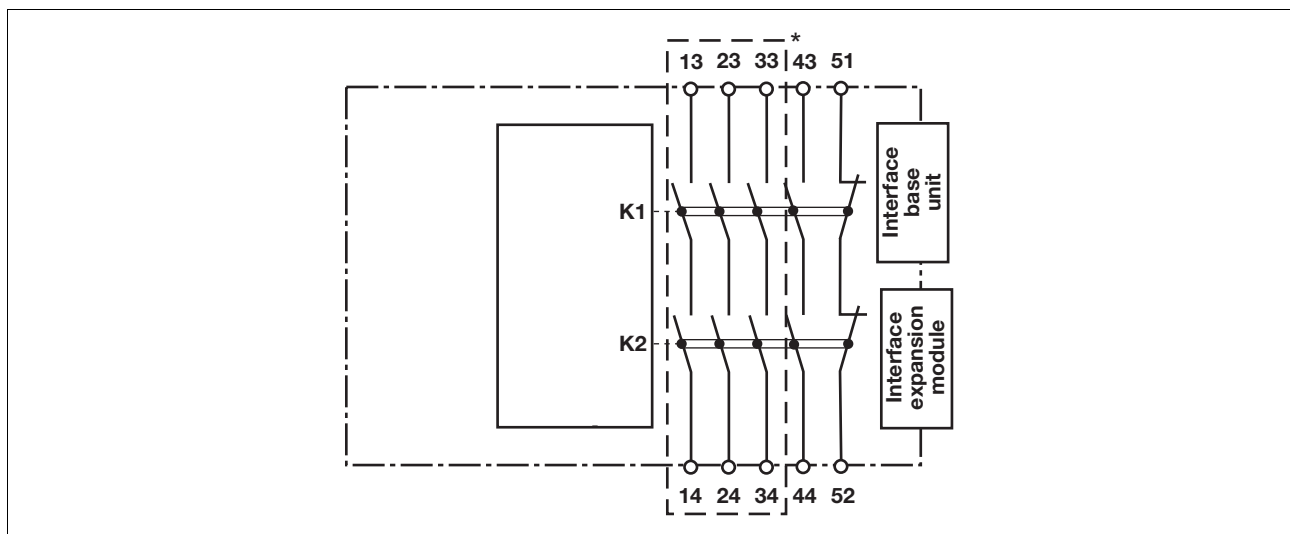

*Safe separation in accordance with EN 60947-1, 6 kV

Up to PL e of EN ISO 13849-1 PNOZ s7.2

Function description

with PNOZsigma s7.1:

- ▶ Dual-channel operation and supply voltage via PNOZsigma connector

with PNOZsigma expander modules:

- ▶ Dual-channel operation and supply voltage via PNOZsigma connector

Timing diagram

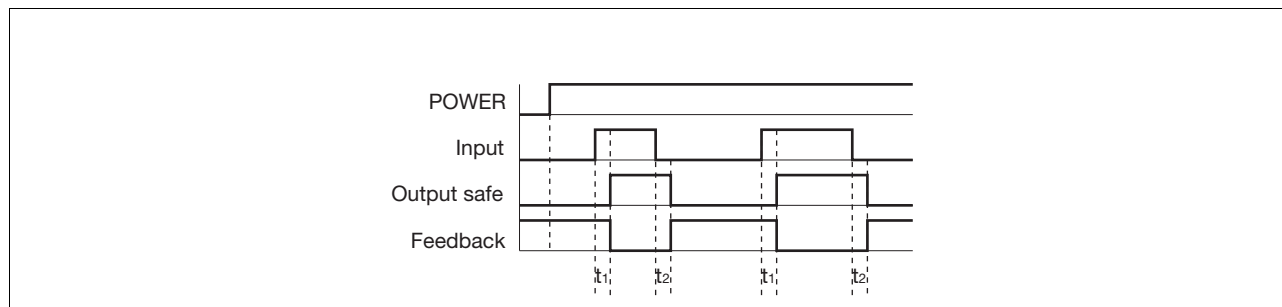

Key

- ▶ Power: Supply voltage
- ▶ Input: Input circuits
- ▶ Output safe: Safety contacts 13-14, 23-24, 33-34, 43-44
- ▶ Feedback: Feedback loop 51-52
- ▶ t_1 : Switch-on delay
- ▶ t_2 : Delay-on de-energisation

Wiring

Please note:

- ▶ Information given in the "Technical details" must be followed.
- ▶ Outputs 13-14, 23-24, 33-34, 43-44 are safety contacts, output 51-52 is an auxiliary contact (e.g. for display).
- ▶ To prevent contact welding, a fuse should be connected before the output contacts (see technical details).
- ▶ Use copper wire that can withstand 60/75 °C.
- ▶ Sufficient fuse protection must be provided on all output contacts with capacitive and inductive loads.