

**EQUIVALENT CIRCUIT BLOCK DIAGRAMS/WIRING DIAGRAM**

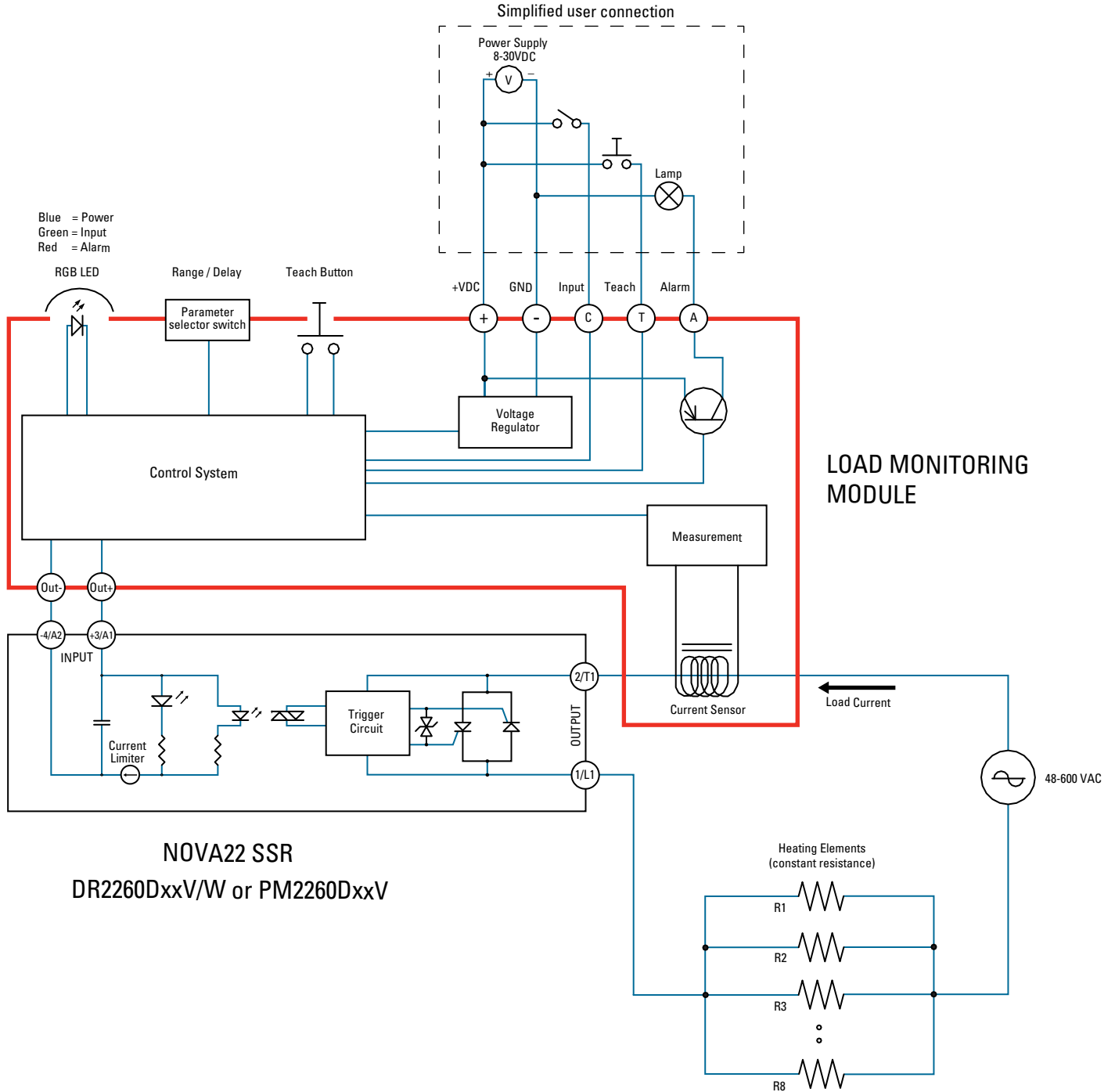

**INSTALLATION INSTRUCTIONS**

- Remove the ID marker and input connector from the NOVA22 relay.
- Wire input and output as shown in the Wiring Diagram. Before wiring terminal 2/T1 pass the wire through the module hole. For recommended wire sizes and terminal torques see TABLE 1.
- Mount the module onto the relay as shown in steps 1 and 2.
- Proceed to configure the module:
  - ◆ Select the maximum load current (20 Amps or 50 Amps) and the alarm delay (0.1, 1 or 5 secs) using the parameter selector switch. NOTE: Parameter selector switch is updated at startup or if no input signal is present.
  - ◆ Turn on all power supplies.
  - ◆ Press TEACH-IN button (or apply external TEACH-IN input) for 3 seconds to store the nominal load current value. LED will blink Blue 3 times when TEACH process is complete.
  - ◆ Module will start monitoring the system once TEACH-IN button has been released. Refer to TABLE 1 and Status Charts for detailed operation and status.
- For module removal follow steps 3 and 4.

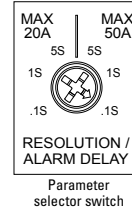

**Module Mounting**

**STEP 1:**  
Align the module to the bottom of SSR

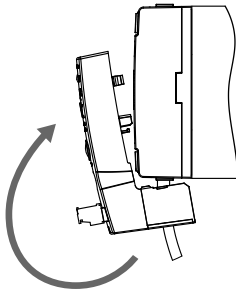

**STEP 2:**  
Push to put into place as shown

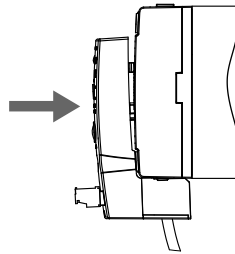

**Module Removal**

**STEP 3:**  
Loosen screw of terminal 2/T1

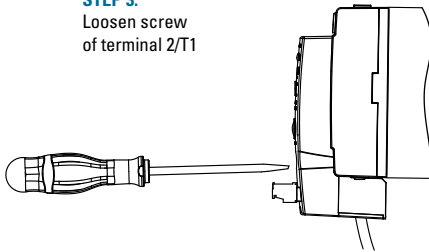

**STEP 4:**  
Hold module and pull to remove

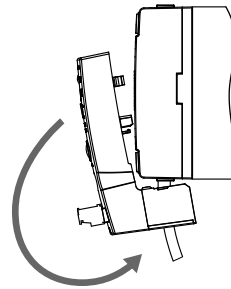

**TABLE 1. Recommended Torque and Wire Sizes**

Terminal	Max. Screw Torque [in-lb (Nm)]	Wire Size (Solid / Stranded)	Wire Pull-Out Strength (lb)[N]
Output	18-20 (2.0-2.2)	20 AWG (0.75 mm <sup>2</sup> ) [minimum]	25 [111]
		10 AWG (6 mm <sup>2</sup> )	70 [310]
		8 AWG (10 mm <sup>2</sup> ) [maximum]	70 [310]
Input	1.6 (0.19)	28 AWG (0.09 mm <sup>2</sup> ) [minimum]	2.2 [9.8]
		14 AWG (2.5 mm <sup>2</sup> ) [maximum]	22 [98]