

RXZE2FA

mounting adaptor with fixing lugs for panel - for relays
RXM and RPM



Main

Accessory / separate part category	Mounting accessories
Accessory / separate part designation	Mounting adaptor with fixing lugs for panel
Device short name	RXZ
Sale per indivisible quantity	10

Complementary

Accessory / separate part destination	Zelio Relay RPM Zelio Relay RXM
Product compatibility	Plug-in relay RXM (2 C/O) Plug-in relay RXM (4 C/O) Plug-in relay RXM (3 C/O) Plug-in relay RPM (2 C/O)
Shape of pin	Flat
Product weight	0.002 kg

Environment

Contractual warranty

Warranty period	18 months
-----------------	-----------

Dimensions

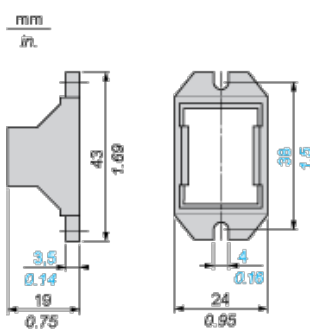

Mounting Adapter for Panel

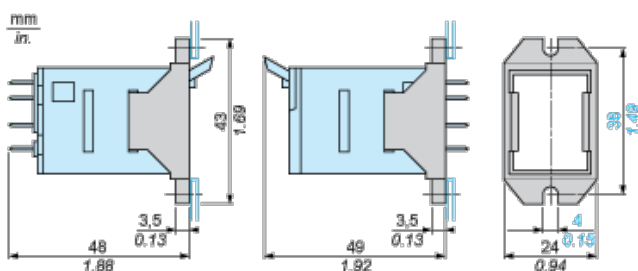

The information provided in this documentation contains general descriptions and/or technical characteristics of the performance of the products contained herein. This documentation is not intended as a substitute for and is not to be used for determining suitability or reliability of these products for specific user applications. It is the duty of any such user or integrator to perform the appropriate and complete risk analysis, evaluation and testing of the products with respect to the relevant specific application or use thereof. Neither Schneider Electric Industries SAS nor any of its affiliates or subsidiaries shall be responsible or liable for misuse of the information contained herein.