

## SAFEMASTER Emergency Stop Module BG 5925

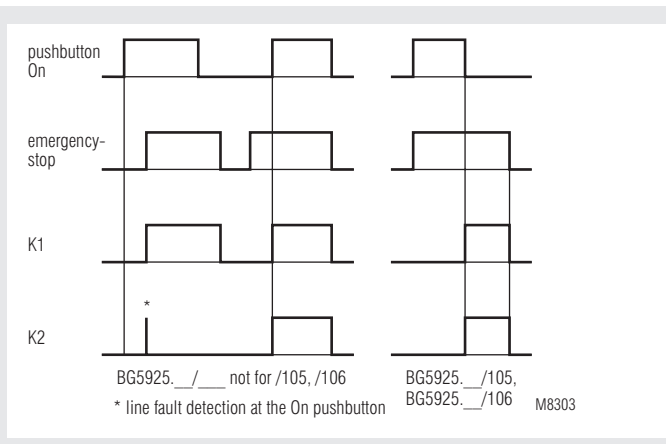

- According to
  - Performance Level (PL) e and category 4 to EN ISO 13849-1: 2008
  - SIL Claimed Level (SIL CL) 3 to IEC/EN 62061
  - Safety Integrity Level (SIL) 3 to IEC/EN 61508
- Output: max. 3 NO contacts, see contacts
- Single and 2-channel operation
- Line fault detection on On-button
- Manual restart or automatic restart, switch S2
- With or without cross fault monitoring in the E-stop loop, switch S1
- LED indicator for channel 1 and 2 and Power
- Removable terminal strips
- Wire connection: also 2 x 1.5 mm<sup>2</sup> stranded ferruled (isolated), DIN 46 228-1/-2/-3/-4 or 2 x 2.5 mm<sup>2</sup> stranded ferruled DIN 46 228-1/-2/-3
- Width 22.5 mm

### Function Diagram



### Approvals and Marking



\* see variants

### Applications

- Protection of people and machines
- Emergency stop circuits on machines
  - Monitoring of safety gates

### Indicators

- LED Power: on when supply connected  
LED K1/K2: on when relay K1/K2 energized

### Block Diagram

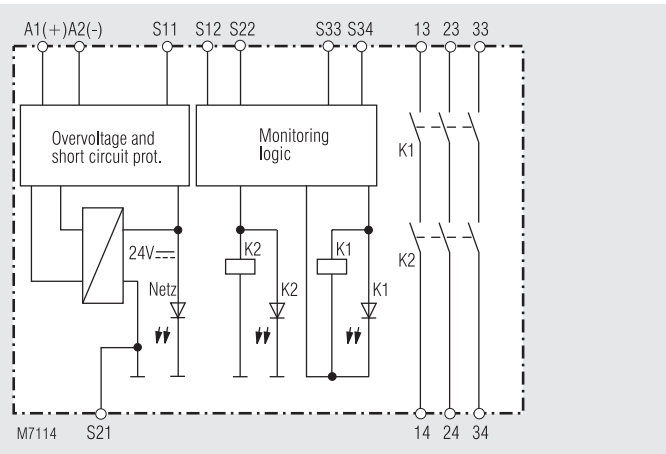

### Circuit Diagrams

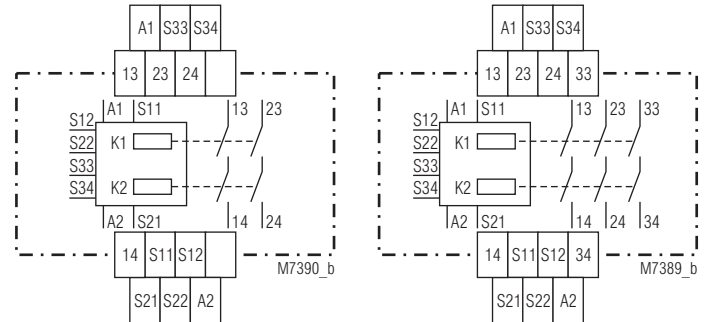

BG 5925.02

BG 5925.03

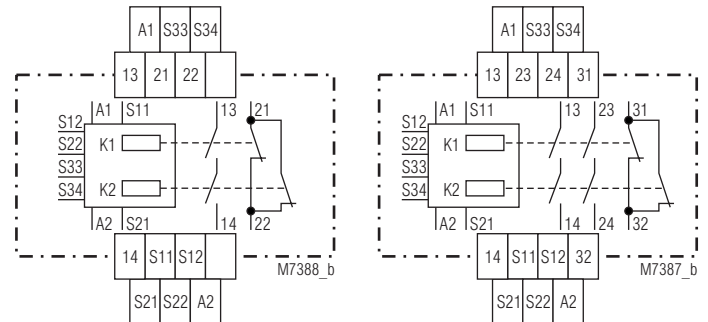

BG 5925.16

BG 5925.22

### Connection Terminals

Terminal designation	Signal designation
A1+	+ / L
A2	- / N
S12, S22, S33, S34	Inputs
S11, S21	Outputs
13, 14, 23, 24, 33, 34	Forcibly guided NO contacts for release circuit
21, 22, 31, 32	Forcibly guided indicator output

## Unit programming

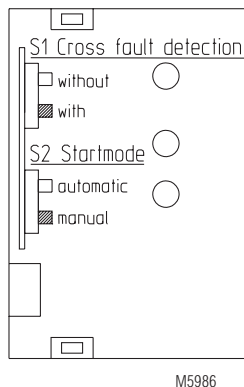
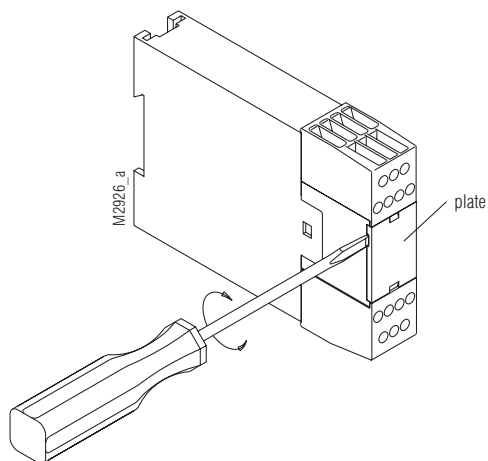

	S1	S2	Function
	available in uniti		
BG 5925	yes	yes	
BG 5925._./101	yes	yes	
BG 5925._./102	no	no	automatic + without
BG 5925._./103	no	no	manual + with
BG 5925._./104	no	no	automatic + with
BG 5925._./105	no	yes	without
BG 5925._./106	no	yes	with

Disconnect unit before setting of S1  
Drawing shows setting at the state of delivery

### Notes

Line fault detection on On-button:

The line fault detection is only active when S12 and S22 are switched simultaneously. If the On-button is closed before S12, S22 is connected to voltage (also when line fault across On-Button), the output contacts will not close. A line fault across the On-button which occurred after activation of the relay, will be detected with the next activation and the output contacts will not close. If a line fault occurs after the voltage has been connected to S12, S22, the unit will be activated because this line fault is similar to the normal On-function. The gold plated contacts of the BG 5925 mean that this module is also suitable for switching small loads of 1 mVA - 7 VA, 1 mW - 7 W in the range 0.1 - 60 V, 1 - 300 mA. The contacts also permit the maximum switching current. However since the gold plating will be burnt off at this current level, the device is no longer suitable for switching small loads after this (not for variant BG 5925.22/102).

The terminal S21 permits the operation of the device in IT-systems with insulation monitoring, serves as a reference point for testing the control voltage and is used to connect the E-stop loop when cross fault monitoring is selected.

Connecting the terminal S21 to the protective ground bridges the internal short-circuit protection of Line A2 (-). The short-circuit protection of line A1 (+) remains active.

To alter the functions automatic start - manual start and with or without cross fault monitoring, the switches S1 and S2 are used. These are located behind the front cover (see unit programming).

The setting with or without cross fault monitoring on E-stop buttons is made with S1. S2 is used to change between automatic and manual restart. On automatic start also the terminals S33 - S34 have to be linked. For connection please see application examples.

### ATTENTION - AUTOMATIC START!



According to IEC/EN 60 204-1 part 9.2.5.4.2 and 10.8.3 it is not allowed to restart automatically after emergency stop. Therefore the machine control has to disable the automatic start after emergency stop.

### Technical Data

#### Input circuit

<b>Nominal Voltage <math>U_N</math>:</b>	DC 24 V, AC/DC 24 V AC 230 V with variant /105 and /106
<b>Voltage range</b>	DC AC/DC
at 10% residual ripple:	0.9 ... 1.1 $U_N$ 0.95 ... 1.1 $U_N$
at 48% Residual ripple:	0.8 ... 1.1 $U_N$ 0.8 ... 1.1 $U_N$
AC:	— 0.85 ... 1.1 $U_N$
<b>Nominal consumption:</b>	DC approx. 2 W
<b>Min. Off-time:</b>	250 ms
<b>Control voltage on S11:</b>	DC 23 V at $U_N$
<b>Control current over S12, S22:</b>	40 mA at $U_N$
<b>Min. voltage between terminals S12, S22 and S21:</b>	DC 21 V when relay activated and $U_N$ on A1 - A2
<b>Short-circuit protection:</b>	Internal PTC
<b>Overvoltage protection:</b>	Internal VDR

#### Output

<b>Contacts</b>	2 NO contacts
BG 5925.02:	3 NO contact
BG 5925.03:	1 NO, 1 NC contact
BG 5925.16:	2 NO, 1 NC contact
BG 5925.22:	The NO contacts are safety contacts. <b>ATTENTION! The NC contacts 21-22 or 31-32 can only be used for monitoring.</b>

#### Operate delay typ. at $U_N$ :

Manual start:	40 ms
automatic start:	250 ms
BG 5925._./101:	100 ms

#### Release delay typ. at $U_N$ :

Disconnecting the supply:	50 ms
Disconnecting S12, S22:	15 ms

#### Contact type:

<b>Nominal output voltage:</b>	forcibly guided AC 250 V DC: see limit curve for arc-free operation
<b>Switching of low loads:</b> (contact 5 $\mu$ Au) (contact AgNi)	$\geq 100$ mV $\geq 1$ mA $\geq 10$ mA / DC 24 V
<b>Thermal current <math>I_{th}</math>:</b> on 1 contact path:	max. 5 A see current limit curve

#### Switching capacity

to AC 15:		
NO contacts:	3 A / AC 230 V	IEC/EN 60 947-5-1
NC contacts:	2 A / AC 230 V	IEC/EN 60 947-5-1
to DC 13:		
NO contacts:	1 A / DC 24 V	IEC/EN 60 947-5-1
NC contacts:	1 A / DC 24 V	IEC/EN 60 947-5-1

#### Electrical contact life

to AC 15 at 2 A, AC 230 V:	$10^5$ switching cycles IEC/EN 60 947-5-1
to DC 13 at 1 A, DC 24 V:	$> 1.5 \times 10^5$ switching cycles

#### Permissible operating frequency:

max. 1 200 operating cycles / h

#### Short circuit strength

max. fuse rating:	6 A general-purpose IEC/EN 60 947-5-1
line circuit breaker:	C 8 A

#### Mechanical life:

$10 \times 10^6$  switching cycles