

Performance Characteristics cont.

PL-001L-N - Field of View (Unit: m)

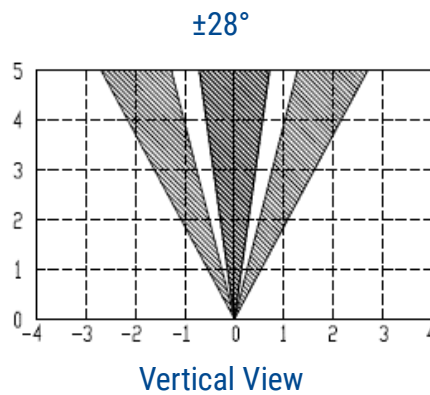

PL-001L-N - Projection View

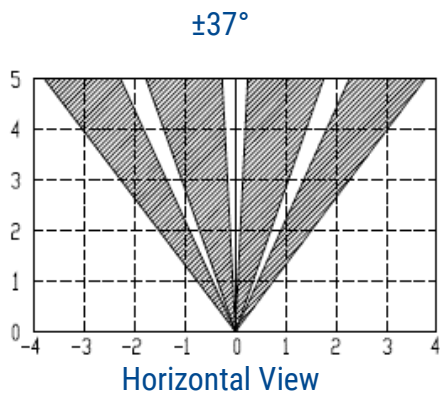
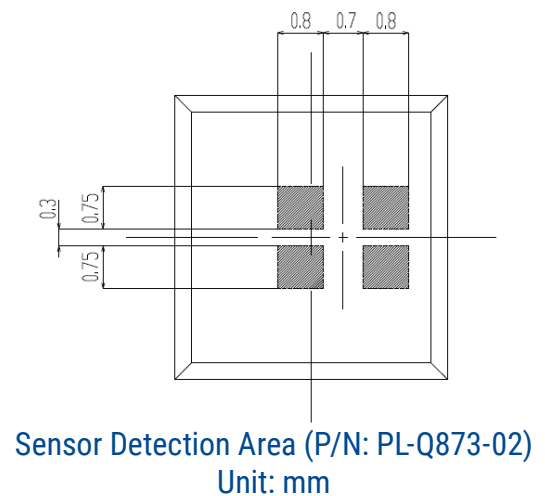
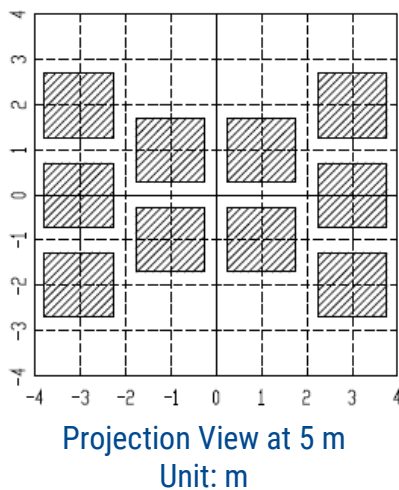

Detecting Performance with Different Materials

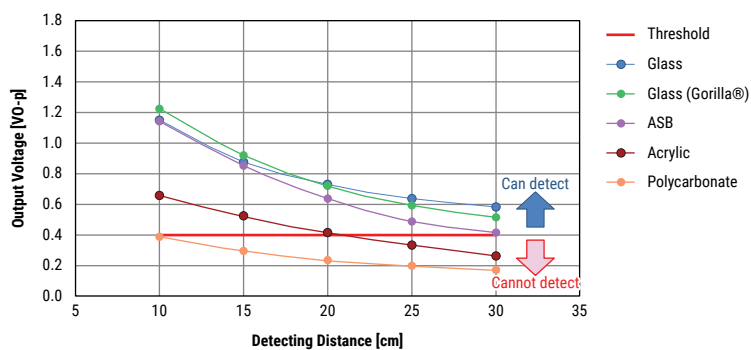

Measuring conditions: Transfer velocity - 1 m/s
 Heat source size - 170×70 mm (relative to hand)
 Temperature difference - $\Delta 10^\circ\text{C}$
 Each material thickness - 1 mm (clear color)

Dimensions in mm

Sensor - Dimensions in mm

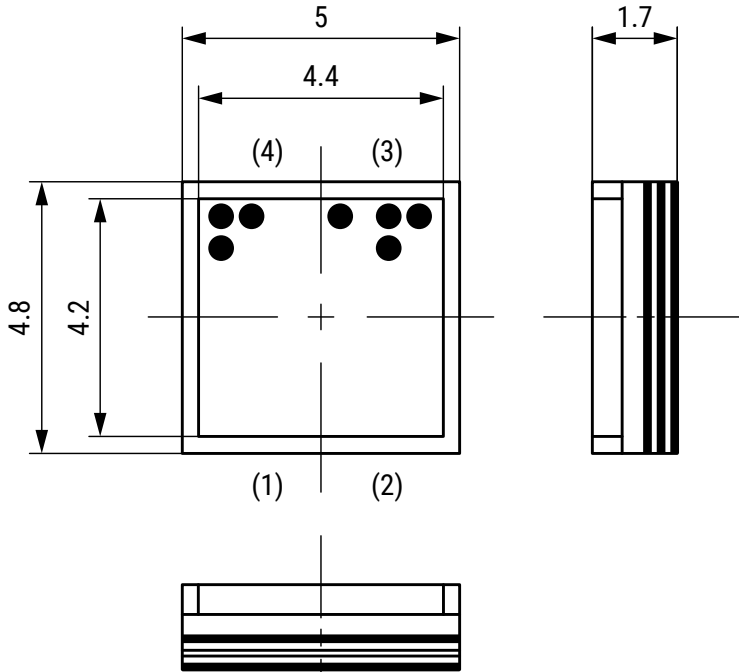

Sensor - Land Pattern in mm

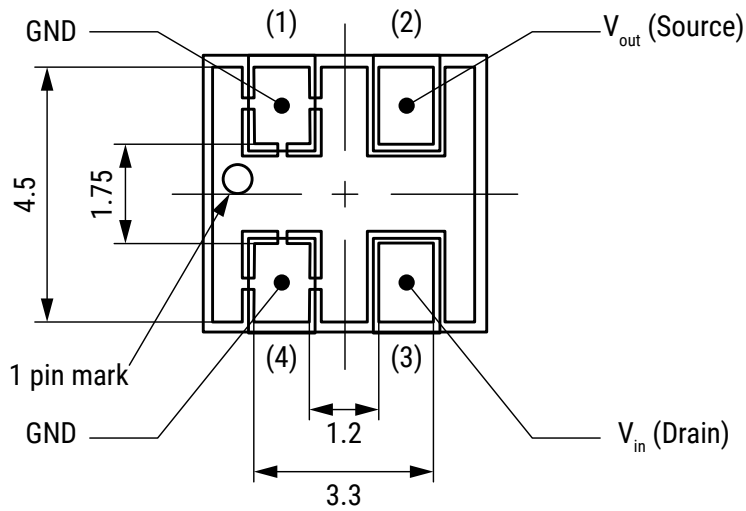
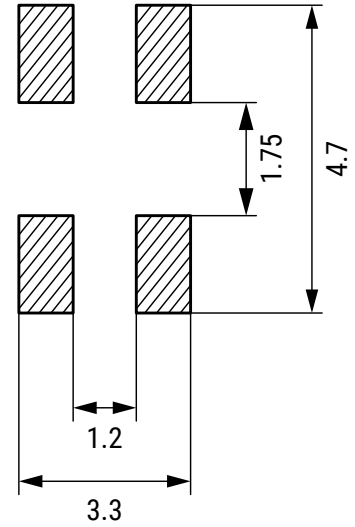

Sensor - Pin Assignment

Pin Number	Pin Name
1	GND
2	V_{out} (Source)
3	V_{in} (Drain)
4	GND