

MP Motion Sensor (AMN2, 3, 4)

2. Absolute maximum ratings (Measuring condition: ambient temperature = 25°C 77°F) (Common to All types)

Items	Absolute maximum ratings
Power supply voltage	-0.3 to 7 V DC
Usable ambient temperature	-20 to 60°C -4 to +140°F (No freezing and condensing at low temperature.)
Storage temperature	-20 to 70°C -4 to +158°F

3. Electrical characteristics (Common to All types)

1) Digital output

Items	Symbol	Electrical characteristics *() is low current consumption type	Measured conditions *() is low current consumption type
Rated operating voltage	Minimum	Vdd	3.0 V DC (2.2 V DC)
	Maximum		6.0 V DC (3.0 V DC)
Rated consumption current (Standby) Note)	Typical	Iw	170 μA (46 μA)
	Maximum		300 μA (60 μA)
Output current (when detecting)	Maximum	Iout	100 μA
Output voltage (when detecting)	Minimum	Vout	Vdd -0.5
Circuit stability time	Typical	Twu	7 s
	Maximum		30 s

Note: The current which is consumed during detection consists of the standby consumed current plus the output current.

2) Analog output

Items	Symbol	Specified value	Measured conditions
Operating voltage	Minimum	Vdd	4.5 V DC
	Maximum		5.5 V DC
Consumption current	Typical	Iw	170 μA
	Maximum		300 μA
Output current	Maximum	Iout	50 μA
Output voltage range	Minimum	Vout	0 V
	Maximum		Vdd
Output offset average voltage	Minimum	Voff	2.3 V
	Typical		2.5 V
	Maximum		2.7 V
Steady-state noise	Typical	Vn	155 m Vp-p
	Maximum		300 m Vp-p
Detection sensitivity	Minimum	Vh or Vl	0.45 V
Circuit stability time	Maximum	Twu	45 s

Note: To set to the same detection performance as the digital output type, set the output voltage to the offset voltage (2.5V) ±0.45V (i.e. 2.95V or more and 2.05V or less).

TIMING CHART

1. Digital output

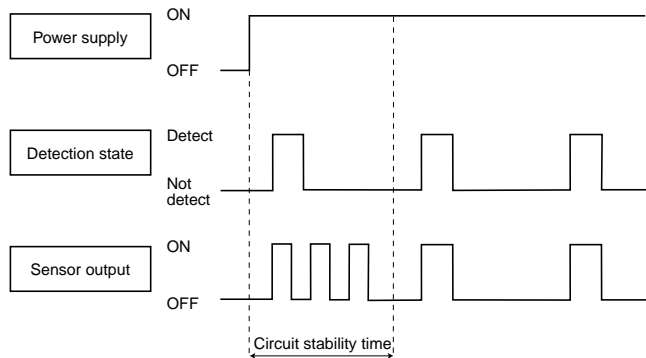

Note: Circuit stability time: 30s max.

While the circuitry is stabilizing after the power is turned on, the sensor output is not fixed in the "on" state or "off" state. This is true regardless of whether or not the sensor has detected anything.

2. Analog output

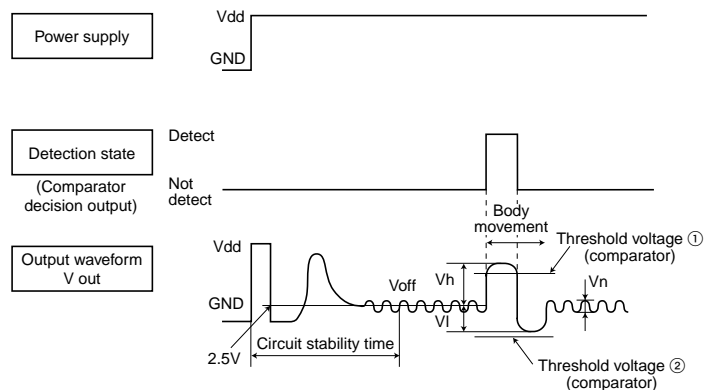

Note: Circuit stability time: 45s max.

While the circuitry is stabilizing after the power is turned on, the sensor output is not fixed in the "on" state or "off" state. This is true regardless of whether or not the sensor has detected anything.

MP Motion Sensor (AMN2, 3, 4)

DETECTION PERFORMANCE

1. Standard detection type

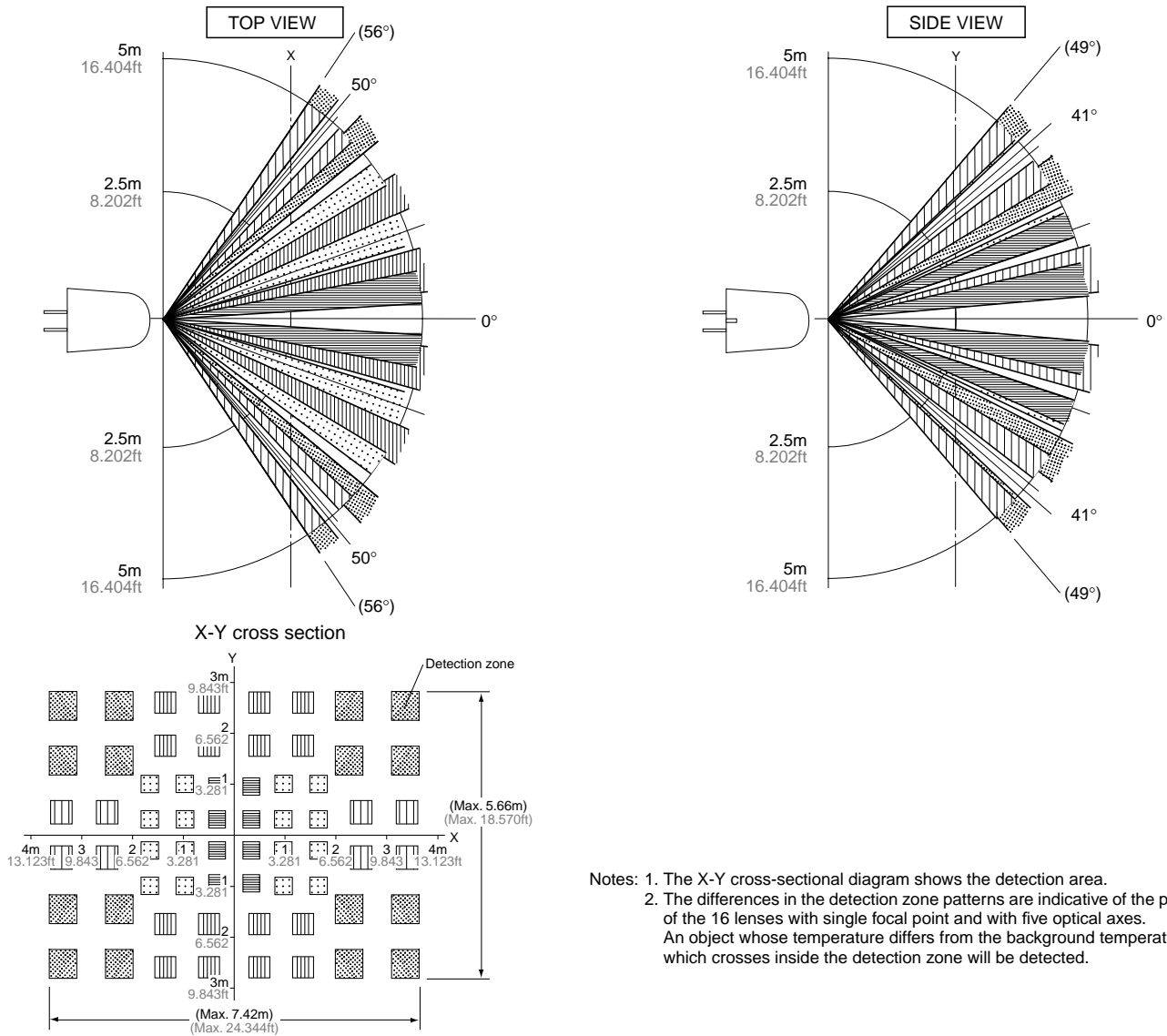

2. Slight motion detection type

