

1. CP430, CP470, CP474, CP770 and CP774

1.1 Order data

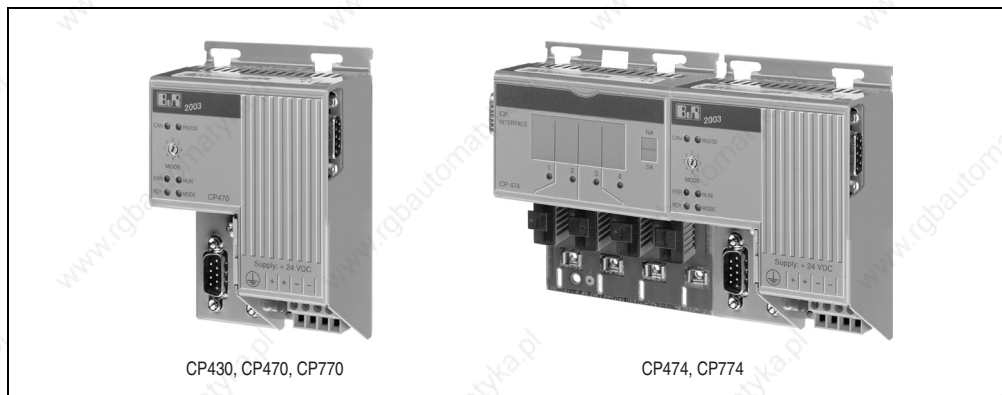

Model number	Short description
7CP430.60-1	2003 CPU, 100 KB SRAM, 256 KB FlashPROM, 24 VDC, 7 W supply, 1 RS232 interface, 1 CAN interface, CAN: electrically isolated, network capable, max. 64 digital / 32 analog I/O points
7CP470.60-2	2003 CPU, 350 KB SRAM, 512 KB FlashPROM, 24 VDC, 14 W supply, 1 RS232 interface, 1 CAN interface, CAN: electrically isolated, network capable, max. 128 digital / 64 analog I/O points
7CP474.60-2	2003 CPU, 750 KB SRAM, 512 KB FlashPROM, 24 VDC, 12.6 W supply, 1 RS232 interface, 1 CAN interface, CAN: electrically isolated, network capable, 4 slots for screw-in modules, max. 208 digital / 80 analog I/O points
7CP770.60-1	2003 CPU, 100 KB SRAM, 256 KB FlashPROM, 100-240 VDC, 14 W supply, 1 RS232 interface, 1 CAN interface, CAN: electrically isolated, network capable, max. 128 digital / 64 analog I/O points
7CP774.60-1	2003 CPU, 100 KB SRAM, 512 KB FlashPROM, 100-240 VDC, 12.6 W supply, 1 RS232 interface, 1 CAN interface, CAN: electrically isolated, network capable, 4 slots for screw-in modules, max. 208 digital / 80 analog I/O points
Optional accessories	
4A0006.00-000	Lithium battery, 3 V / 950 mAh, button cell Note: Backup battery included in delivery
0AC201.9	Lithium batteries, 5 pcs., 3 V / 950 mAh, button cell
0G0001.00-090	Cable PC <-> PLC/PW, RS232, online cable
7AC911.9	Bus connector, CAN
0AC912.9	Bus adapter, CAN, 1 CAN interface
0AC913.92	Bus adapter, CAN, 2 CAN interfaces, including 30 cm attachment cable (DSUB connector)
0MC111.9-1	PC card, 2 MB FlashPROM
0MC112.9-1	PC card, 4 MB FlashPROM
0MC211.9	PC card, 2 MB SRAM

Table 1: Order data

1.2 Technical data

Name	CP430	CP470 / CP770	CP474 / CP774
Short description			
System module	CPU		
Interfaces	1x RS232, 1x CAN bus		
Processor			
Fastest task class cycle time	1 ms		
Typical instruction cycle time	1.6 μ s	1.6 μ s	0.8 μ s
Standard memory User RAM System PROM User PROM	100 KB SRAM 256 KB FlashPROM 256 KB FlashPROM	350/100 KB SRAM 512/256 KB FlashPROM 512/256 KB FlashPROM	750/100 KB SRAM 512 KB FlashPROM 512 KB FlashPROM
Data buffering Backup battery Buffer current Typical Maximum	Lithium battery 3 V / 950 mAh 1.6 μ A 60 μ A	Lithium battery 3 V / 950 mAh 1.6 μ A 60 μ A	Lithium battery 3 V / 950 mAh 2.2 μ A 110 μ A
Hardware watchdog	Yes		
Voltage monitoring	Internal supply monitored for overvoltage and undervoltage		
Peripherals			
Real-time clock Resolution	Nonvolatile memory 1 s		
Status indicators	LEDs		
I/O bus interface	9-pin DSUB socket		
Slots for screw-in modules Suitable for IF modules	No	No	4 1 - 3
Interfaces			
Interface IF1 Type Electrical isolation Design Max. distance Max. transfer rate	RS232 No 9-pin DSUB plug 15 m / 19200 bit/s 57.6 kBit/s		
Interface IF2 Type Electrical isolation Design Max. distance Maximum transfer rate	CAN Yes 9-pin DSUB plug 1000 m 500 kBit/s		
General information			
Operation on module slot	1	1	1 + 2
Logical module slots	Max. 4	Max. 8	Max. 12
analog module slots	Max. 2	Max. 4	Max. 4
Possible module addresses for analog modules	1 - 4	1 - 8	1 - 8

Table 2: Technical data

CPUs • CP430, CP470, CP474, CP770 and CP774

Name	CP430	CP470 / CP770	CP474 / CP774
Visual Components capability	No		
ACOPOS capability	No	No	Yes
Certification	CE, C-UL-US, GOST-R		
Mechanical characteristics			
Dimensions	System 2003 single-width		System 2003 double-width
Protection type	IP20		
Operating temperature	0°C to +60°C		
Horizontal installation	0°C to +50°C		
Vertical installation	0°C to +50°C		
Storage temperature	-25°C to +60°C		
Relative humidity	5 to 95%, non-condensing		
Comment	Backup battery included in delivery		
Power supply			
	CP430	CP470/CP474	CP770/CP774
Input voltage			
Minimum	18 VDC	18 VDC	85 VAC
Rated	24 VDC	24 VDC	100 - 240 VAC
Maximum	30 VDC	30 VDC	264 VAC
Input voltage frequency	-	-	47 - 63 Hz
Power consumption	Max. 9.5 W	Max. 20 W	Max. 20 W
Output power for I/O ports	7 W ¹⁾	14/12.6 W ¹⁾	14/12.6 W ¹⁾

Table 2: Technical data (cont.)

1) Integrated power supply on pin 4 of the RS232 interface for simple PANELWARE controllers, e.g. P126.

1.3 Status indicators

LED	Meaning
CAN	Data transfer to or from CAN controller
RS232	Indicates if data is being transmitted or received
ERR	Lit when in Service mode
RUN	Lit in RUN and in Service mode
RDY	Lit when in Service mode
MODE	Lit when programming FlashPROM
1, 2, 3, 4	These LEDs show the operating state of the respective screw-in module.
Not lit	Screw-in module defective or not inserted
Blinking slowly	Communication error with screw-in module Exception: On the IF361 and IF371 modules, a slow-blinking LED means that frame driver communication is running correctly.
Blinking quickly	Screw-in module is new or has been exchanged with another module type
Lit	Screw-in module is ready for operation

Table 3: Status indicators

1.4 Power supply

The CPUs are either supplied with 24 VDC or with 100 to 240 VAC. The pin assignments are printed on the module.



CP430, CP470, CP474	CP770, CP774
<p>Both "+" and "-" pins are connected to each other internally</p> 	<p>Both "N" and "L" pins are connected to each other internally</p> 

Table 4: Power supply

1.5 Interfaces

The CPU has two interfaces:



Figure 1: Interfaces

1.6 CAN bus

The electrically isolated standard fieldbus interface is used for the following tasks:

- Communication with other control systems
- System decentralization and remote I/O expansion using System 2003 components and a CAN bus controller

We recommend using the 7AC911.9 T-connector for coupling to a CAN network. A terminal resistor is integrated into the T-connector for the bus termination, which can be switched on or off.

CAN interface		
Pin	Assignment	
1	NC	 <p>9-pin DSUB plug</p>
2	CAN_L	
3	CAN_GND	
4	NC	
5	NC	
6	Reserved	
7	CAN_H	
8	NC	
9	NC	

Table 5: Pin assignments for CAN interface

1.7 RS232 interface

This interface, which is not electrically isolated, is primarily intended for programming the CPU. The RS232 interface can also be used as a general interface (e.g. P126 visualization, printer, bar code reader, etc.).

RS232 interface		
Pin	Assignment	Name
1	NC	Reserved
2	RXD	Receive signal
3	TXD	Transmit signal
4	+5 VDC / max. 500 mA	Panel supply
5	GND	Ground
6	NC	Reserved
7	RTS	Request To Send
8	CTS	Clear To Send
9	GND	Ground

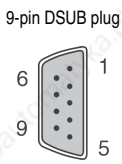
Table 6: Pin assignments for RS232 interface

1.8 Mode switch



Figure 2: Mode switch

The operating mode is set with the Mode switch. The switch setting can be evaluated by the application program at any time. The operating system only interprets the switch position when switched on.

Switch position	Operating mode	Description
\$0	Boot	In this switch position, the operating system can be installed via the RS232 interface configured as online interface. User Flash is only deleted after the update begins.
\$1 - \$8	Run	RUN mode, the application is running. These switch settings are freely available for use in an application (e.g. CAN node number).
\$9 - \$E	Reserved	Reserved for B&R expansions – these settings are not allowed to be used!
\$F	Diagnostics	The CPU boots in diagnostics mode. Program sections in User RAM and User FlashPROM are not initialized. After diagnostics mode, the CPU always boots with a cold restart .

Table 7: Operating modes

1.9 Programming the System Flash

1.9.1 General information

CPUs are delivered with a runtime system. The node number switch is set to switch position \$0 when delivered i.e. bootstrap loader mode is set.

A corresponding switch position must be set (\$1 to \$8) in order to boot the PLC in RUN mode. A runtime system update is only possible in RUN mode.

1.9.2 Runtime system update

The runtime system can be updated using the programming system. When updating the runtime system (online runtime system update), the following procedure must be carried out:

- 1) An online runtime system update is only possible if the processor is in RUN mode. To do this, the set node number must be in the range from \$1 to \$8.
- 2) Switch on the power.
- 3) The runtime system update is performed via the existing online connection. An online runtime update is possible using the serial RS232 onboard interface.
- 4) Start B&R Automation Studio.

- 5) Start the update procedure by calling the **Services** command from the **Project** menu. Select **Transfer Operating System...** from the menu shown. Now follow the instructions from B&R Automation Studio.
- 6) A dialog box is displayed for configuring the runtime system version. The runtime system version is already pre-selected by the user's project settings. Using the drop-down menu, the runtime system versions stored in the project can be selected. Clicking on the **Browse** button allows the selected runtime system version to be loaded from the hard drive or from the CD.

Pressing **Next >** opens a pop-up window, which allows the user to select whether the modules should also be downloaded with SYSTEM ROM as the target memory during the following runtime system update. Otherwise, modules can also be downloaded later together with an application download.

After pressing **Next >**, a dialog box appears where the user can set the CAN transfer rate, CAN ID and the CAN node number (the CAN node number set here is only relevant if an interface module does not have a CAN node number switch). The CAN node number must be between decimal 01 and 99. It's made up of the switch position 1 - 8 and a decimal offset entry. Assigning a unique node number is especially important with online communication over a CAN network (INA2000 protocol).

- 7) The update procedure is started by pressing **Next >**. The update progress is shown in a message box.

Information:

User flash is cleared.

- 8) When the update procedure is complete, the online connection is automatically reestablished.
- 9) The PLC is now ready for use.

A runtime system update is not only possible using an online connection, but also using a CAN network or a serial network (INA2000 protocol), depending on the system configuration.

1.10 CP interface

The CPUs CP474 and CP774 are equipped with four slots for screw-in modules. The required screw-in modules are inserted into the CP interface and screwed firmly into place.

TPU mode is possible on all 4 slots.

The screw-in interface modules can be operated in slots 1, 2 and 3.

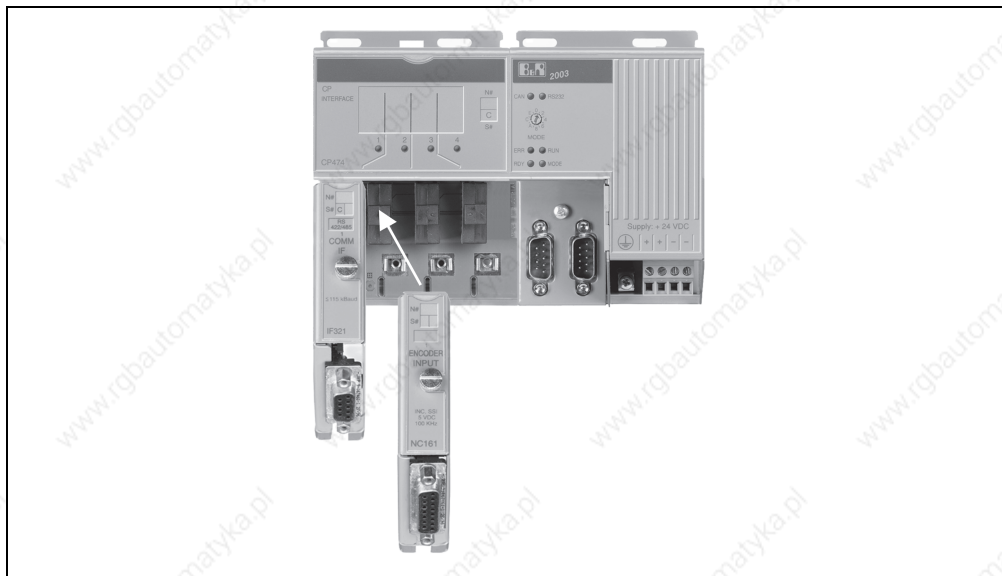

Figure 3: CP interface

1.10.1 Overview

The following screw-in modules can be used on the CP interface.

Module	Type	Description
7AI261.7	Analog IN	1 input used to evaluate a full-bridge strain gauge
7AI294.7	Analog IN	4 inputs for potentiometer displacement gauge
7AI351.70	Analog IN	1x ± 10 V or 1x 0 - 20 mA (1x ± 20 mA also possible) potentiometer operation
7AI354.70	Analog IN	4x ± 10 V
7AI774.70	Analog IN	4x 0 - 20 mA (4x ± 20 mA also possible)
7AO352.70	Analog OUT	2x ± 10 V / 0 - 20 mA
7AT324.70	Analog IN	4x temperature sensor (PT100, PT1000, KTY10 or KTY84)
7AT352.70	Analog IN	2x PT100 3-line
7AT664.70	Analog IN	4x thermocouple
7DI135.70	Digital IN	4x 24 VDC, 50 kHz
7DI138.70	Digital IN	10x 24 VDC, 20 kHz
7DI140.70	Digital IN	10x 24 VDC, 50 kHz
7DO135.70	Digital OUT	4x 12 - 24 VDC, 0.1 A, 100 kHz
7DO138.70	Digital OUT	8x 24 VDC, 0.5 A
7DO139.70	Digital OUT	8x 12 - 24 VDC, 0.5 A
7DO164.70	Digital OUT	4x 48 - 125 VAC, 50 mA, zero voltage input
7IF311.7	Interface	1x RS232
7IF321.7	Interface	1x RS485/RS422
7IF361.70-1	Interface	1x Profibus DP slave
7IF371.70-1	Interface	1x CAN
7NC161.7	Encoder module	1x 100 kHz, 5 / 24 VDC

Table 8: Screw-in modules

1.10.2 Commands

The following commands can be used on the CP Interface:

- Reading the screw-in module type
- Switching off automatic mode
- Switching on automatic mode

1.11 Legend strips

A legend sheet can be slid into the front of the CPUs CP474 and CP774 from above. These sheets can be used for labeling the screw in modules.

1.12 Data / real-time buffering

The battery voltage is checked cyclically. The cyclic load test of the battery does not considerably shorten the battery life, instead it gives an early warning of weakened buffer capacity.

The status information, "Battery OK" is available from the B&R TRAP function "SYS_battery".

1.13 System variable SYS2003

1.13.1 General information

The system variable SYS2003 is a structure containing the elements "io_scan" and "io_refresh". It must be declared in a task as PLC global.

Element	Variable type	Description
io_scan	UINT	Duration of the last I/O cycle in μ s
io_refresh	SINT	0 ... I/O data is more than one cycle old 1 ... I/O data is current

Table 9: System variable SYS2003

Information:

If digital IO data points are used in the HSTC (high speed task class), the system variable SYS2003 will also be placed in the HSTC. Values in lower task classes will therefore not be consistent.

If no digital I/O data points are placed in the HSTC, the SYS2003 variable will use the 10 ms operating system clock.

1.14 Changing the battery

1.14.1 Battery data

Model number 4A0006.00-000 0AC201.9	1 pcs. 5 pcs.
Short description	Lithium battery, 3 V / 950 mAh, button cell
Storage temperature	-20 to +60°C
Storage time	Max. 3 years at 30°C
Relative humidity	0 to 95% (non-condensing)

Table 10: Battery data

1.14.2 Buffer duration

Buffer current	CP470 / CP770	CP474 / CP774
Typical	1.6 μ A	2.2 μ A
Maximum	60 μ A	110 μ A

Table 11: Buffer duration

Information:

B&R recommends changing the batteries after five years of operation.

1.14.3 Procedure

The product design allows the battery to be changed with the PLC switched either on or off. In some countries, safety regulations do not allow batteries to be changed while the module is switched on.

Information:

Data stored in RAM will be lost if the battery is changed with the PLC switched off.

- 1) Touch the mounting rail or ground connection (not the power supply!) in order to discharge any electrostatic charge from your body.
- 2) Remove the cover from the lithium battery holder using a screwdriver.

- 3) Remove the battery from the holder by pulling the removal strip (do not use uninsulated tools -> risk of short circuiting). The battery should not be held by its edges. **Insulated** tweezers may also be used for removing the battery.

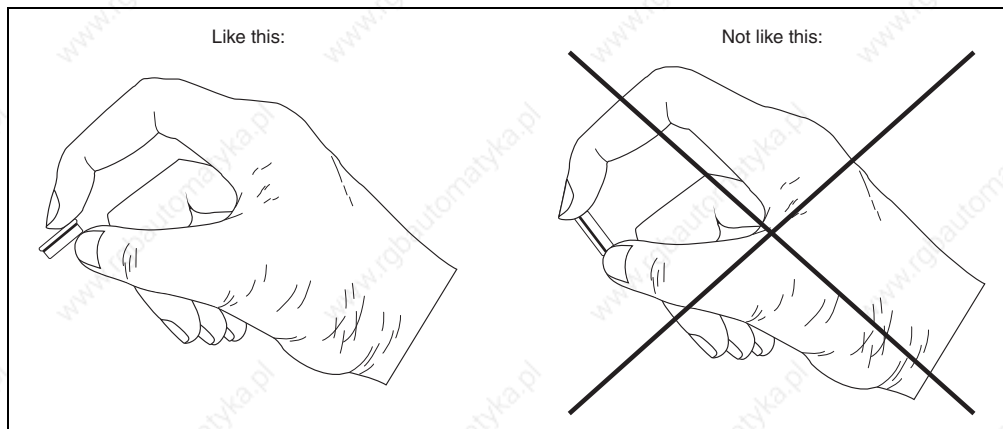

Figure 4: Handling the battery

- 4) Insert the new battery with correct polarity. The removal strip should be protruding from the battery holder and the "+" side of the battery should be facing downward. In order to be able to remove the battery again in future, the removal strip must protrude from the **upper side of the battery**.

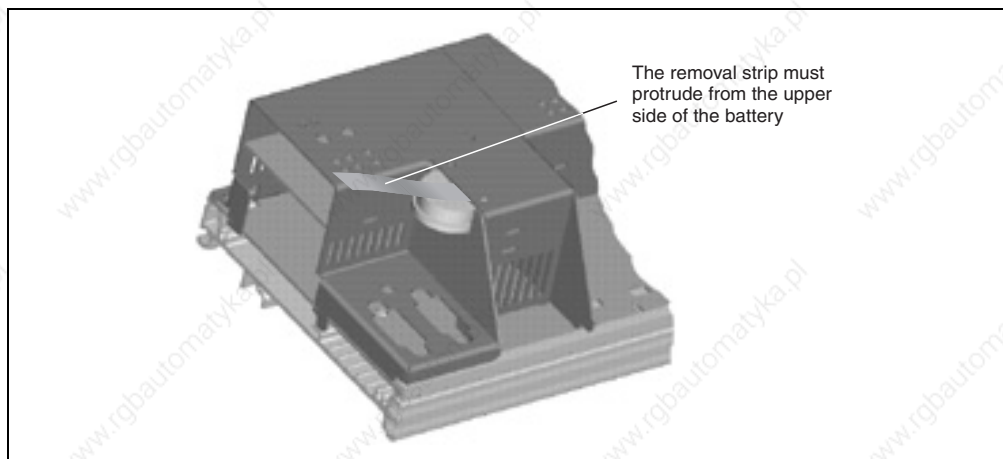

Figure 5: Removal strips

- 5) Now wrap the end of the removal strip over the top of the battery and insert it underneath the battery so that it does not protrude from the battery holder.

- 6) Replace cover. Ensure that the slot in the edge of the cover faces the front of the module (1). Insert the upper edge of the cover in the battery holder opening (2). Press the lower end of the cover home firmly (3).

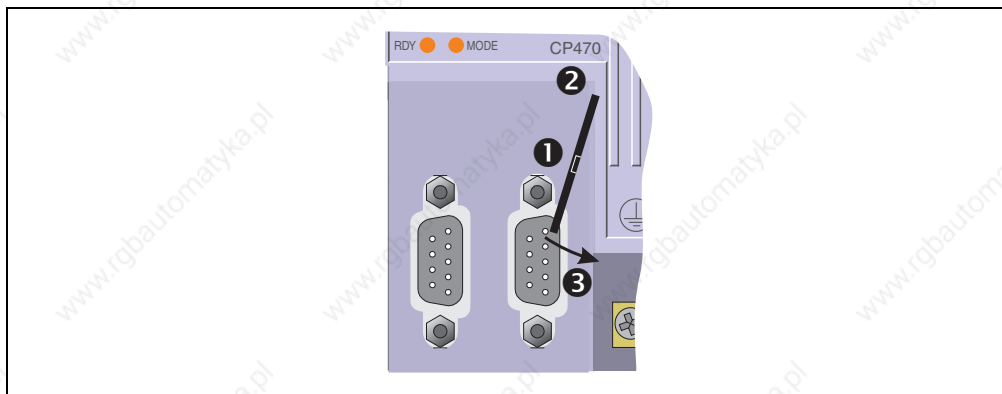

Figure 6: Replace cover

Information:

Lithium batteries are considered hazardous waste. Used batteries should be disposed of accordingly.