

LV0104CS

Block Diagram

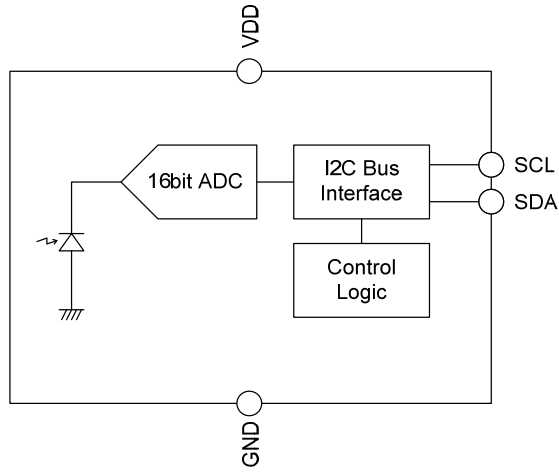

Application circuits

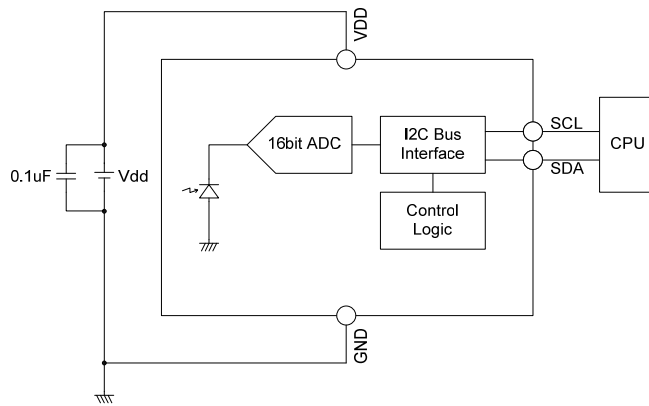

LV0104CS

Spectrum Sensitivity Characteristic

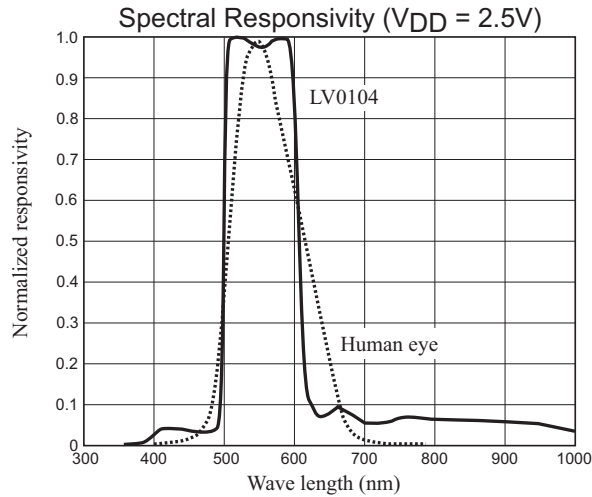

I²C Interface

The control command is received from the operation of the device by the I²C bus (Two-wire serial interface). The obtained data is output to the operation by the I²C bus.

I²C Bus Timing Diagram

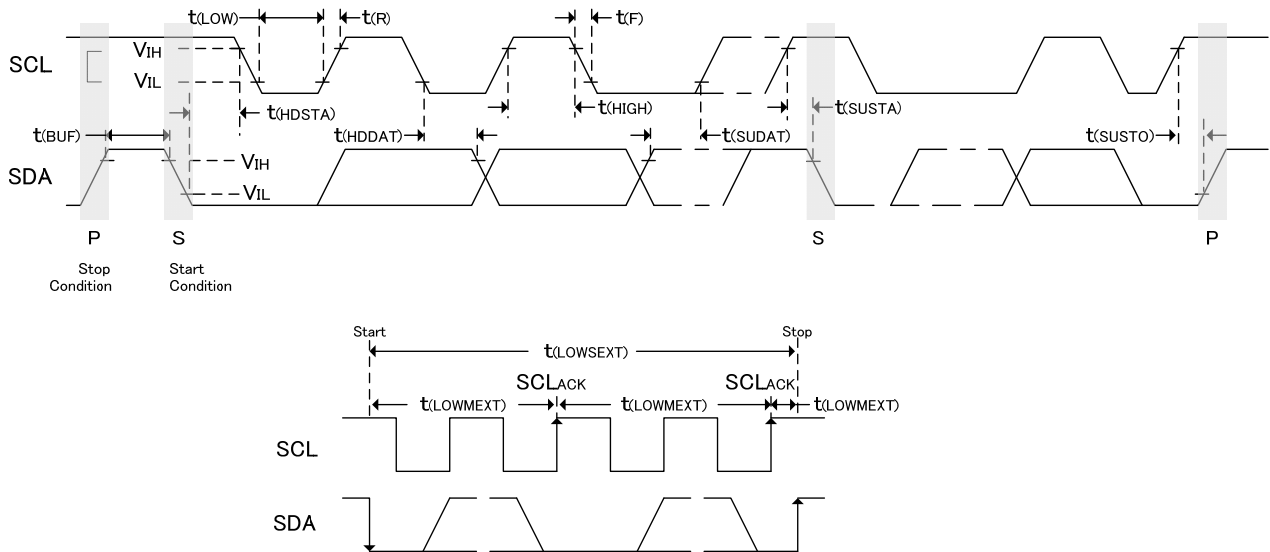

Serial Interface Timing

Parameter	Symbol	Standard Mode		Fast Mode		Unit
		min	max	min	max	
Clock frequency	f(SCL)	10	100	10	400	kHz
Bus free time between start and stop condition	t(BUF)	4.7		1.3		μs
Hold time after (repeated) start condition. After this period, the first	t(HDSTA)	4.0		0.6		μs
Repeated start condition setup time	t(SUSTA)	4.7		0.6		μs
Stop condition setup time	t(SUSTO)	4.0		0.6		μs
Data hold time	t(HDDAT)	300		90		ns
Data setup time	t(SUDAT)	250		100		ns
I ² C clock (SCL) low period	t(LOW)	4.7		1.3		μs
I ² C clock (SCL) high period	t(HIGH)	4.0		0.6		μs
Clock / data fall time	t(F)		300		300	ns
Clock / data rise time	t(R)		1000		300	ns

*Specified by design and characterization ; not production tested.