

**Absolute Maximum Ratings** ( $T_A = +25^\circ\text{C}$ )

Supply Voltage Between VDD and GND	3.6V
REXT	(-0.5V + GND) to (0.5V + VDD)
VOUT	(-0.5V + GND) to (0.5V + VDD)
VOUT Short-Circuit Current	<10mA
ESD Rating	
Human Body Model (Tested per JESD22-A114E)	2kV

**Thermal Information**

Thermal Resistance (Typical)	$\theta_{JA}$ ( $^\circ\text{C}/\text{W}$ )	$\theta_{JC}$ ( $^\circ\text{C}/\text{W}$ )
6 Ld ODFN (Notes 4, 5)	88	7.94
Maximum Die Temperature	+90 $^\circ\text{C}$	
Storage Temperature	-40 $^\circ\text{C}$ to +100 $^\circ\text{C}$	
Operating Temperature	-40 $^\circ\text{C}$ to +85 $^\circ\text{C}$	
Pb-Free Reflow Profile	see <a href="#">TB487</a>	

**CAUTION:** Do not operate at or near the maximum ratings listed for extended periods of time. Exposure to such conditions may adversely impact product reliability and result in failures not covered by warranty.

**NOTES:**

- $\theta_{JA}$  is measured in free air with the component mounted on a high-effective thermal conductivity test board with “direct attach” features. See Tech Brief [TB379](#).
- For  $\theta_{JC}$ , the “case temp” location is the center of the exposed metal pad on the package underside.

**Electrical Specifications** Unless otherwise noted, all parameter limits are established across the recommended operating conditions:  $V_{DD} = 3\text{V}$ ,  $T_A = -40^\circ\text{C}$  to  $+85^\circ\text{C}$ ,  $R_{EXT} = 100\text{k}\Omega$ , no load at  $V_{OUT}$  and green LED light. (Typical values are at  $T_A = +25^\circ\text{C}$ ). **Boldface limits apply across the operating temperature range, -40 $^\circ\text{C}$  to +85 $^\circ\text{C}$ .**

PARAMETER	SYMBOL	TEST CONDITIONS	MIN (Note 6)	TYP	MAX (Note 6)	UNIT
Range of Input Light Intensity for Square Root Relationship to be Held	E			0.01 - 100		lux
Operating Supply Voltage	$V_{DD}$		<b>1.8</b>		<b>3</b>	V
Supply Current	$I_{DD}$	E = 0 lux, -40 $^\circ\text{C}$ to +60 $^\circ\text{C}$		0.7	2	$\mu\text{A}$
		E = 100 lux		23	<b>35</b>	$\mu\text{A}$
Light-to-Voltage Accuracy	$V_{OUT}$	E = 10 lux		0.65		V
		E = 50 lux		1.35		V
		E = 100 lux	<b>1.40</b>	1.85	<b>2.30</b>	V
Voltage Output in the Absence of Light	$V_{DARK}$	E = 0 lux, -40 $^\circ\text{C}$ to +60 $^\circ\text{C}$		0.95	20	mV
Output Voltage Variation Over Three Light Sources: Fluorescent, Incandescent and Halogen	$\Delta V_{OUT}$			10		%
Power Supply Rejection Ratio	PSRR	E = 100 lux		0.12		mV/V
Maximum Output Compliance Voltage at 95% of Nominal Output	$V_{O-CMPL}$			$V_{DD} - 0.7\text{V}$		V
Maximum Output Voltage Swing	$V_{O-MAX}$				<b><math>V_{DD}</math></b>	V
Rise Time	$t_R$	E = 0 lux to 100 lux		95		$\mu\text{s}$
Fall Time	$t_F$	E = 100 lux to 0 lux		155		$\mu\text{s}$
Delay Time for Rising Edge	$t_D$	E = 0 lux to 100 lux		350		$\mu\text{s}$
Delay Time for Falling Edge	$t_S$	E = 100 lux to 0 lux		250		$\mu\text{s}$
Short-Circuit Current of Op Amp	$I_{SC}$			$\pm 12$		mA
Slew Rate of Op Amp	$S_R$			13		V/ms
Offset Voltage of Op Amp	$V_{OS}$			$\pm 0.9$		mV

**NOTE:**

- Parameters with MIN and/or MAX limits are 100% tested at  $+25^\circ\text{C}$ , unless otherwise specified. Temperature limits established by characterization and are not production tested.

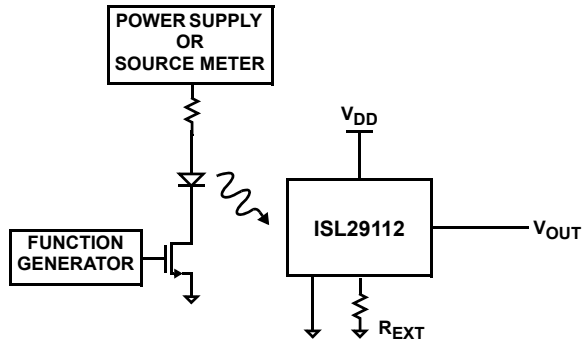

FIGURE 2. TEST CIRCUIT FOR RISE/FALL TIME MEASUREMENT

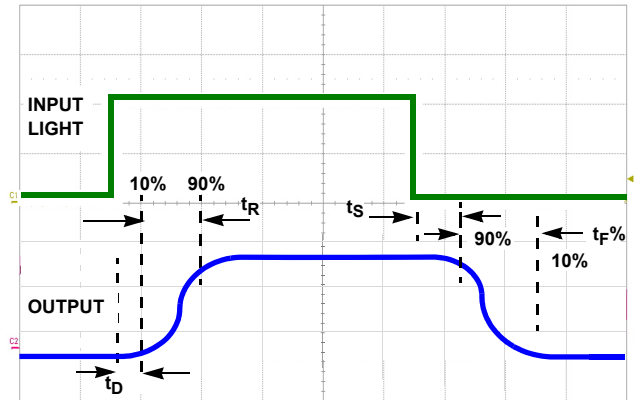

FIGURE 3. TIMING DIAGRAM

### Typical Performance Curves

unless otherwise specified.

$V_{DD} = 3V$ ,  $T_A = +25^\circ C$ ,  $R_{EXT} = 100k\Omega$ , no load at  $V_{OUT}$ , green LED light,

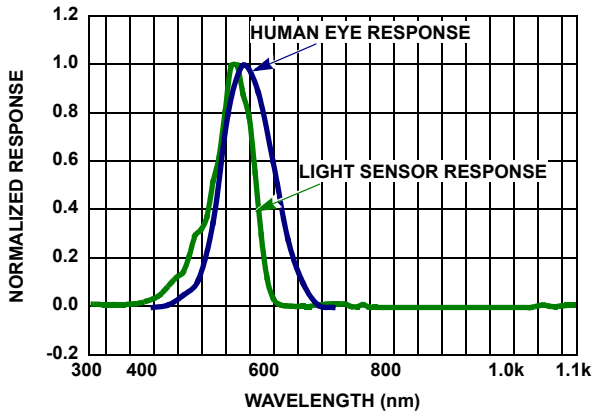

FIGURE 4. SPECTRAL RESPONSE

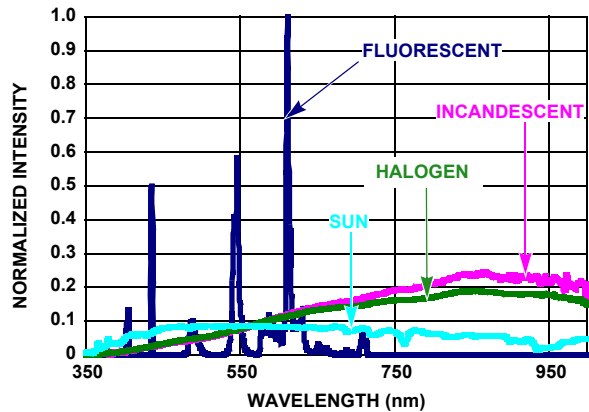

FIGURE 5. SPECTRUM OF FOUR LIGHT SOURCES NORMALIZED BY LUMINOUS INTENSITY (lux)

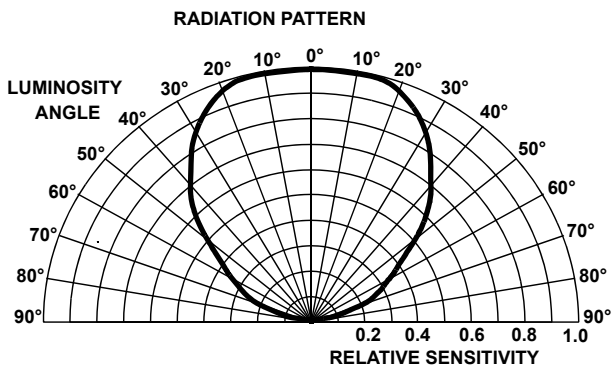

FIGURE 6. RADIATION PATTERN

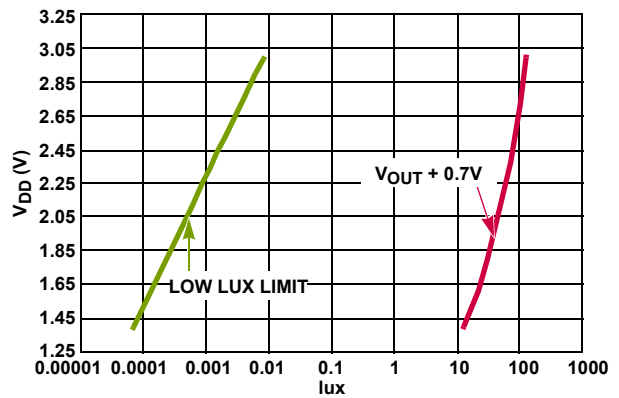

FIGURE 7.  $V_{DD}$  OPERATING RANGE (WHITE LED)