

Airflow Sensors

Microbridge Mass Airflow/Amplified

AWM3000 Series

AWM3000 SERIES ORDER GUIDE (Performance Characteristics @ 10.01 ±0.01 VDC, 25°C)

Catalog Listings	AWM3100V	AWM3150V	AWM3200V	AWM3300V
Flow Range (Full Scale)	+200 sccm	+30 sccm		+1000 sccm
Pressure Range (See Application Note 1)			+2.0" H ₂ O (5 mBar)	
Output Voltage @ Trim Point	5 VDC @ 200 sccm	3.4 VDC @ 25 sccm	5 VDC @ 2" H ₂ O	5 VDC @ 1000 sccm
Null Voltage	1.00 ±0.05 VDC	1.00 ±0.10 VDC	1.00 ±0.08 VDC	1.00 ±0.10 VDC
Null Voltage Shift, Typ. +25° to -25°C, 25° to +85°C	±25 mV	±100 mV	±25 mV	±25 mV
Output Voltage Shift, Max. +25° to -25°C +25° to +85°C	-4% Reading +4% Reading	±5% Reading ±5% Reading	+24% Reading (Note 3) -24% Reading	-5% Reading +5% Reading
Repeatability & Hysteresis, Max.	±0.50% Reading	±1% Reading	±0.50% Reading	±1% Reading
	Min.	Typ.	Max.	
Excitation VDC (Note 2)	8.0	10±0.01	15	
Power Consumption (mW)	—	50	60	
Response Time (msec) (Note 1)	—	1.0	3.0	
Common Mode Pressure (psi)	—	—	25	
Temperature Range	Operating: -25° to +85°C (-13° to +185°F); Storage: -40° to +90°C (-40° to +194°F)			
Termination	2,54 mm (.100") centers, 0,635 mm (0.025") square			
Weight (grams)	10.8			
Shock Rating	100 g peak (5 drops, 6 axes)			

Notes:

1. Initial warm-up time for signal conditioned circuitry is 1 minute max.
2. Output Voltage is ratiometric to supply voltage.
3. Temperature shifts when sensing differential pressure correlates to the density change of the gas over temperature. (See Application Note 1.)
4. Maximum allowable rate of flow change to prevent damage: 5 SLPM/1 sec.

MOUNTING DIMENSIONS (for reference only)

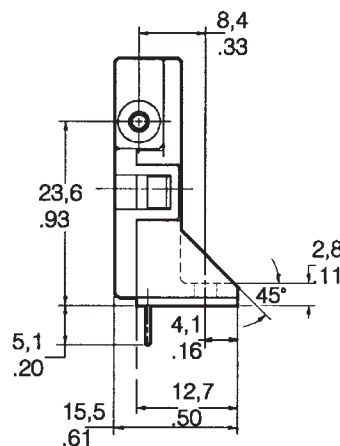
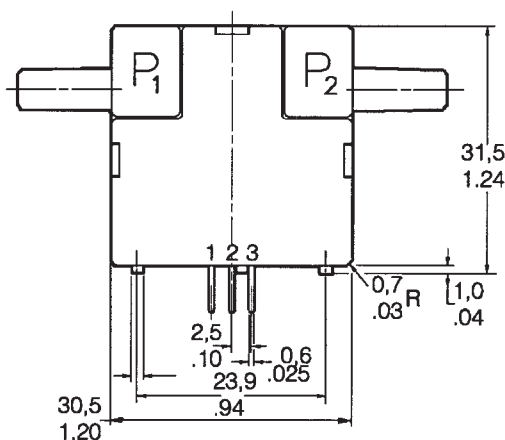
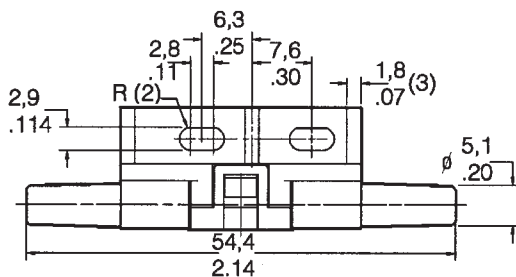

Note: Positive flow direction is defined as proceeding from Port 1 (P1) to Port 2 (P2) and results in positive output. Do not exert a force greater than 4.54kg (10 lbs.) in any direction.

Airflow Sensors

Microbridge Mass Airflow/Amplified

AWM3000 Series

OUTPUT FLOW VS INTERCHANGEABILITY (Note 1)

Performance Characteristics @ 10.0 ±0.01 VDC, 25 C

AWM3100V				AWM3150V				AWM3200V (Note 2)				AWM3300V			
Press. mBar	Flow sccm	Nom. VDC	Tol. ± VDC	Press. mBar	Flow sccm	Nom. VDC	Tol. ± VDC	Flow sccm	Press. " H ₂ O	Nom. VDC	Tol. ± VDC	Press. mBar	Flow sccm	Nom. VDC	Tol. ± VDC
0.49	200	5.00	0.15	2.50	30	3.75	0.70	60.0	2.00	5.00	0.15	3.40	1000	5.00	0.15
0.42	175	4.80	0.16	1.70	20	2.90	0.45	53.0	1.75	4.59	0.15	2.90	900	4.90	0.16
0.35	150	4.50	0.17	0.84	10	1.95	0.20	46.0	1.50	4.16	0.16	2.40	800	4.80	0.17
0.28	125	4.17	0.18	0.42	5	1.50	0.10	38.0	1.25	3.70	0.20	2.00	700	4.66	0.18
0.21	100	3.75	0.19	0.34	4	1.40	0.08	30.0	1.00	3.25	0.22	1.60	600	4.42	0.19
0.14	75	3.27	0.19	0.26	3	1.30	0.08	23.0	0.75	2.65	0.22	1.20	500	4.18	0.20
0.09	50	2.67	0.17	0.17	2	1.20	0.07	16.0	0.50	2.15	0.19	0.80	400	3.82	0.21
0.04	20	1.90	0.13	0.08	1	1.10	0.06	8.0	0.25	1.55	0.11	0.54	300	3.41	0.19
0.00	0	1.00	0.05	0.00	0	1.00	0.05	0.0	0.00	1.00	0.08	0.31	200	2.96	0.17
												0.12	100	2.30	0.14
												0.00	0	1.00	0.10

Notes:

- Numbers in **BOLD** type indicate calibration type, mass flow or differential pressure. Tolerance values apply to calibration type only.
- Differential pressure calibrated devices are not recommended for flow measurement. Use flow calibrated devices for flow measurement.

OUTPUT CURVES

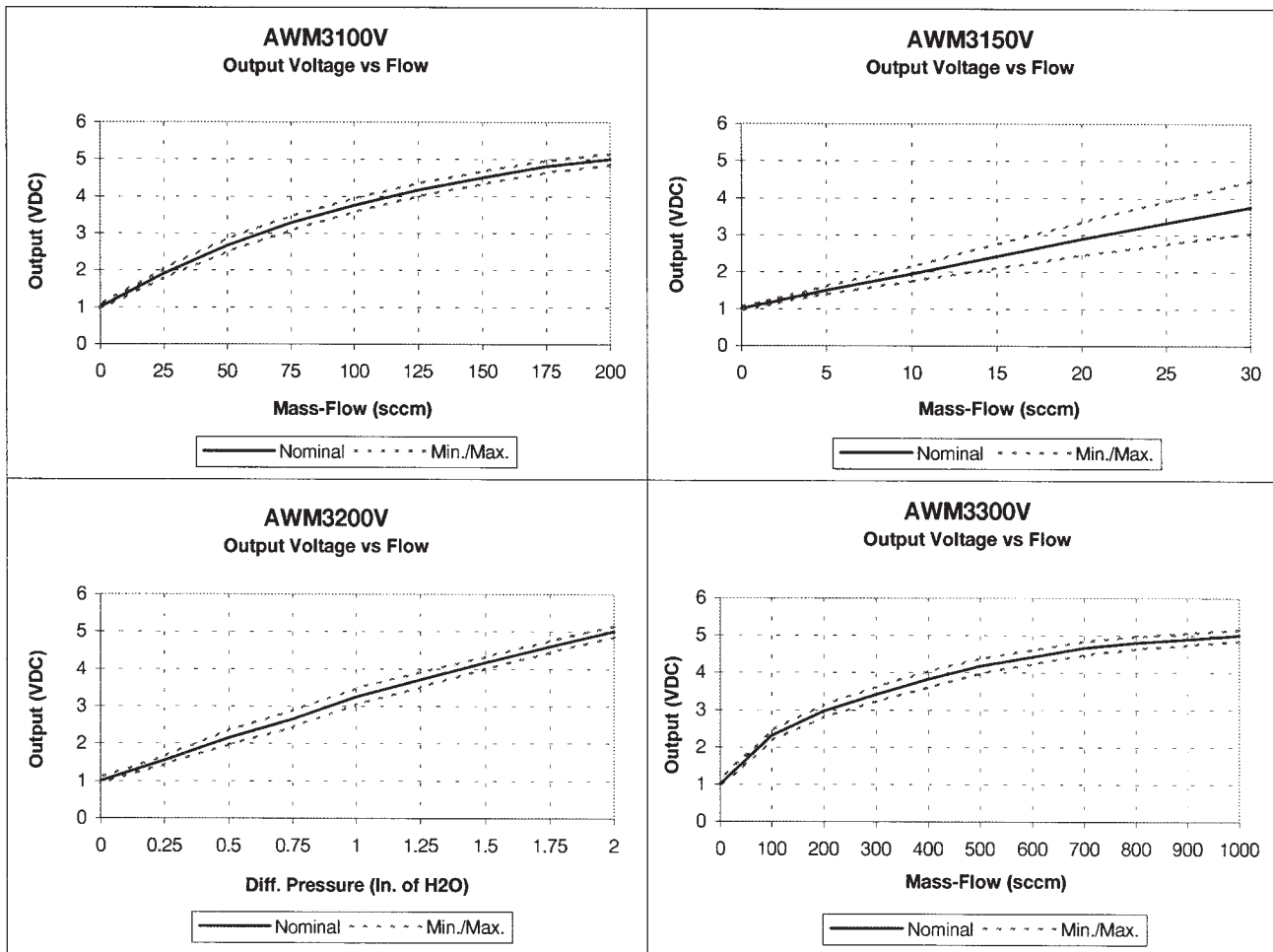

Airflow