



---

**Single-Axis Amplifier  
for Positioning Applications  
with Resolver Evaluation**



The text and the translation of the manual has been worked out very carefully. However, SIEB & MEYER Elektronik GmbH can accept neither obligation nor legal responsibility for incorrect specifications and their consequences, possibly still described in the manual.

Subject to technical alterations!  
©SIEB & MEYER Elektronik GmbH, Lüneburg  
026-servo-bed-26.39-1achs-reso-pos/v2-sm-de-gr/ca



|          |  | page      |
|----------|--|-----------|
| <b>1</b> | <b>Single-Axis Amplifiers</b> .....  | <b>1</b>  |
| 1.1      | General Information .....  | 1         |
| <b>2</b> | <b>Groups of Performances</b> .....  | <b>2</b>  |
| <b>3</b> | <b>Dimensions of Single-Axis Amplifiers</b> .....  | <b>3</b>  |
| 3.1      | Side View .....  | 3         |
| 3.2      | Front View .....   | 4         |
| <b>4</b> | <b>Safety Instruction and Application Advice</b> .....   | <b>5</b>  |
| 4.1      | General Information .....  | 5         |
| 4.2      | Appropriate Use .....  | 5         |
| 4.3      | Transport and Storage .....  | 6         |
| 4.4      | Installation .....   | 6         |
| 4.5      | Electrical Connection .....  | 7         |
| 4.6      | Operation .....  | 7         |
| 4.7      | Maintenance .....  | 8         |
| 4.8      | Guarantee .....  | 8         |
| <b>5</b> | <b>Installation Guidance to Meet Compliance With Electromagnetic Compa-</b><br><b>patibility (EMC)</b> ..... | <b>9</b>  |
| 5.1      | General Information .....  | 9         |
| 5.1.1    | Point 1 .....  | 9         |
| 5.1.2    | Point 2 .....  | 9         |
| 5.1.3    | Point 3 .....  | 9         |
| 5.1.4    | Point 4 .....  | 10        |
| 5.1.5    | Point 5 .....  | 10        |
| 5.1.6    | Point 6 .....  | 10        |
| 5.1.7    | Point 7 .....  | 11        |
| 5.1.8    | Point 8 .....  | 12        |
| 5.1.9    | Point 9 .....  | 14        |
| 5.1.10   | Point 10 .....   | 15        |
| 5.1.11   | Point 11 .....   | 16        |
| 5.2      | Conclusion .....   | 17        |
| 5.3      | Annotation .....   | 18        |
| 5.4      | Literature .....   | 18        |
| 5.5      | Connections Between Machines and Power Modules Meet Compliance with<br>EMC .....                             | 19        |
| 5.6      | Used Standards .....   | 21        |
| <b>6</b> | <b>Mechanical Mounting</b> .....   | <b>22</b> |
| 6.1      | Module Replacement .....   | 23        |
| <b>7</b> | <b>Wiring</b> .....  | <b>24</b> |
| 7.1      | General Information .....  | 24        |
| 7.2      | Motor Cables .....   | 24        |
| 7.3      | Cables for Rotary Encoders .....   | 24        |
| 7.4      | Wiring of the <i>RPM Ref. Value</i> .....  | 25        |
| 7.5      | Wiring of the Angle Pulses .....   | 26        |
| 7.6      | Mains Conditions .....   | 26        |
| 7.7      | Wiring Example .....   | 27        |



---

|          | page   |
|----------|--|
| <b>8</b> | <b>Single-Axis Amplifier for Positioning Applications</b> ..... 28 |
| 8.1      | Front Panel of the Single-Axis Amplifier 26.39.2/.31 ..... 28      |
| <b>9</b> | <b>Pin Assignment of the Amplifier 26.39.2/.31</b> ..... 29        |
| 9.1      | Terminal Strip ..... 29  |
| 9.1.1    | Mains Input for the Main Supply ..... 30                           |
| 9.1.2    | Mains Input for the Logic Voltage ..... 30                         |
| 9.1.3    | Wiring Main Supply with Logic Voltage Supply ..... 31              |
| 9.2      | Submin D Plugs and Connectors ..... 32                             |
| 9.2.1    | St1 - Resolver ..... 32  |
| 9.2.2    | St2 - Analog Signals ..... 32                                      |
| 9.2.3    | St3 - 24 V Signals ..... 33  |
| 9.2.4    | St4 - Angle Pulses ..... 33  |



# 1 Single-Axis Amplifiers

## 1.1 General Information

If a servo drive system is required for only one motor, the use of a 19" rack is not recommended. In order to permit an arrangement saving as much space as possible, a single-axis amplifier has been developed. This device contains both, power module and servo module. Both components are integrated in a compact housing (see 'Dimensions' page 3 and 4).

The power connections are made via a 13-pole terminal strip. The logic connections are fed via submin D plugs and connectors to the amplifier.

In order to achieve a versatile and optimal use of the device, a spectrum of performances from 3 A to 25 A rated current and 60 A peak current is available ('Groups of performances', see page 2).

The integrated servo amplifier is composed of the same components as the multi-axis amplifiers. Detailed information, as for example for the adjustment instruction etc., can be found in the detailed description of the multi-axis amplifiers 26.39.



## 2 Groups of Performances

| type  | ACE                                    |               |               |                |                |                |
|---|--|---------------|---------------|----------------|----------------|----------------|
|   | 3/3                                    | 6/12          | 8/24          | 12/30          | 14/45          | 14/60          |
| intermediate circuit voltage  | 48 VDC, 100 VDC and 310 VDC $\pm 15\%$ |               |               |                |                |                |
| rated currents at 40°C<br>values in brackets at 20 l/sec air<br>flow rate | all rated currents are crest values    |               |               |                |                |                |
|   | 3 A<br>(3A)                            | 6 A<br>(10 A) | 8 A<br>(15 A) | 12 A<br>(20 A) | 14 A<br>(25 A) | 14 A<br>(25 A) |
| peak current, max. 5 sec  | 3 A                                    | 12 A          | 24 A          | 30 A           | 45 A           | 60 A           |
| RPM ref. value  | 0 V to $\pm 10$ V                      |               |               |                |                |                |
| temperature range   | 0°C to 60°C*                           |               |               |                |                |                |
| reduction of capacity for T > 40°C  | - 1,5 % per°C                          |               |               |                |                |                |
| width   | 20 TE                                  |               |               |                |                |                |
| height  | 7 HE                                   |               |               |                |                |                |
| depth   | 330 mm                                 |               |               |                |                |                |

1 TE = 5.08 mm  
1 HE = 44.00 mm



*The specifications refer to an ambient temperature of 40° C. For higher ambient temperatures a cooling fan should be provided. A cooling air flow of at least 20 l/sec. is necessary for all modules. If cooling fans shall not be used, the above mentioned rated currents must be reduced. For the reduction applies: - 1.5 % per °C for T >40° C.*



### 3 Dimensions of Single-Axis Amplifiers

#### 3.1 Side View

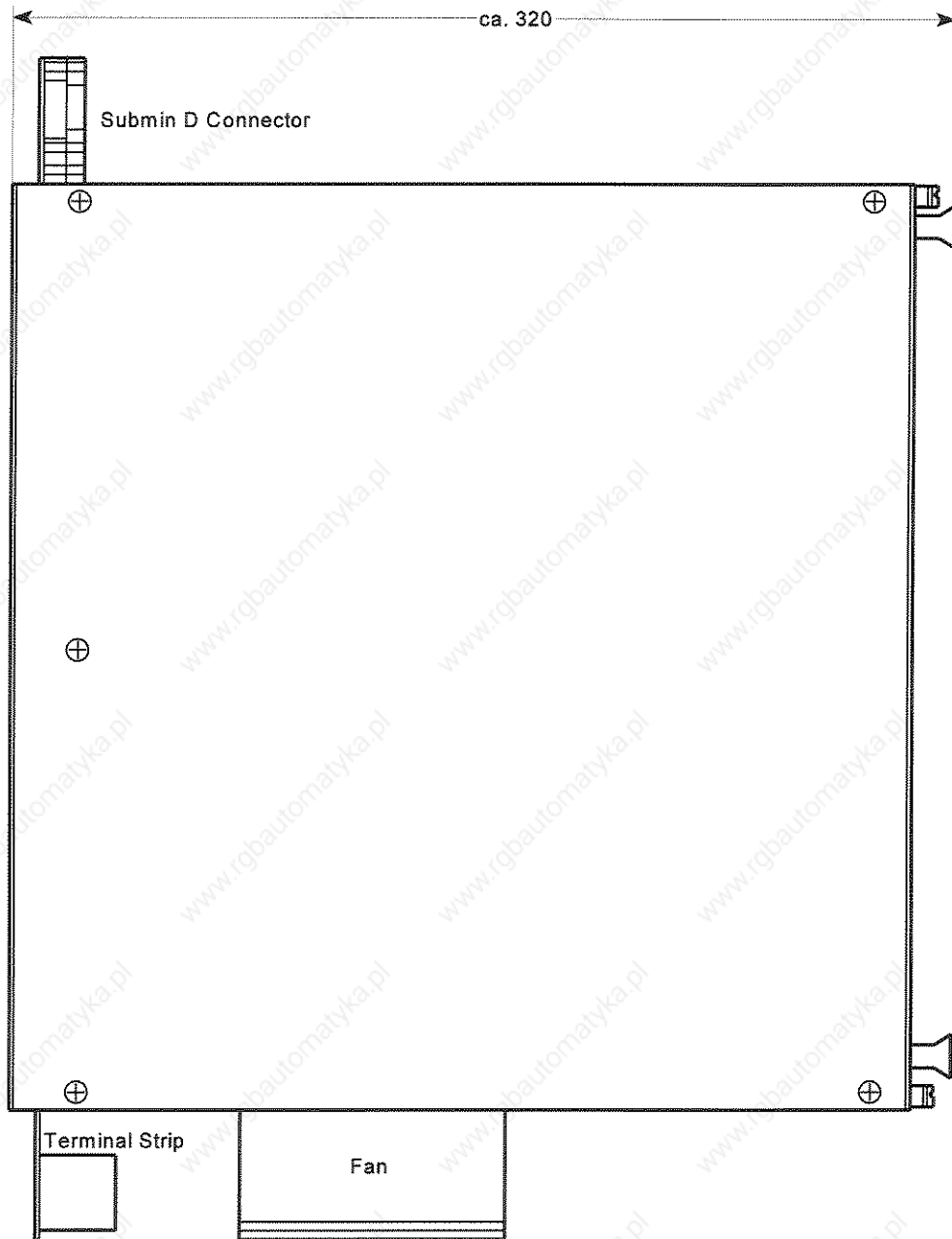



## 3.2 Front View

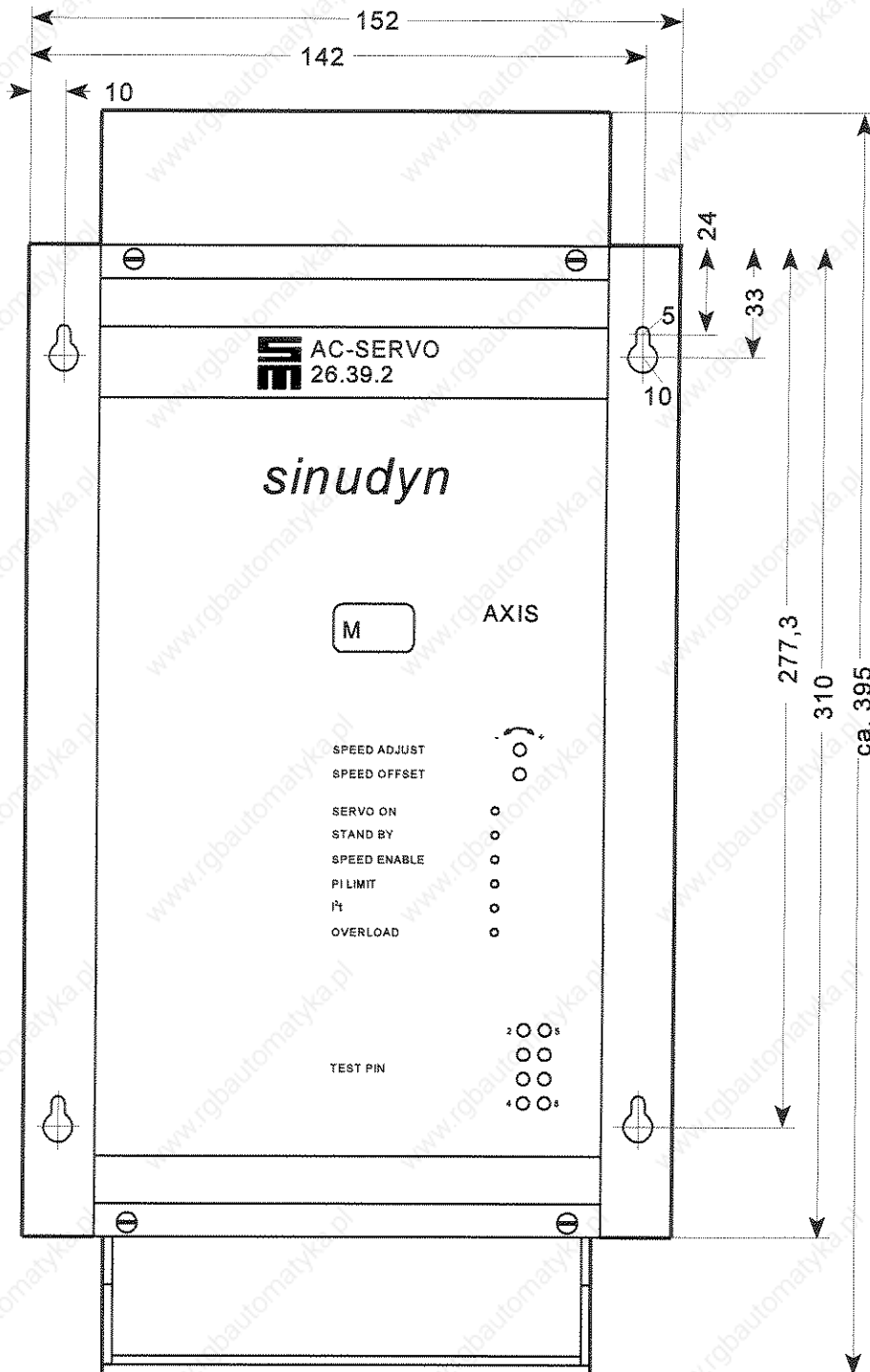



## 4 Safety Instruction and Application Advice

**According to:** Low-Voltage Guideline 73/231/EEC  
Machine Guideline 89/392/EEC  
Electromagnetic Compatibility 89/336/EEC

### 4.1 General Information

In principle, the complete installation, the setting to work and the maintenance should only be carried out from trained staff.

**Definition:** Trained staff, according to this fundamental safety instruction, are persons, familiar with the installation, mounting, setting to work and operation of the product and, are qualified appropriately for the work (DIN VDE 0100 and DIN VDE 0110 and also the legal national rules for prevention of accidents).

According to their protection system, the servo amplifiers can have

- ▶ energized and
  - ▶ hot surfaces
- during the operation.

Subjects can be damaged and persons be injured,

- ▶ when covers are removed illegally
- ▶ during an improper use,
- ▶ when either the installation or operation is incorrect.

Any modifications at and within the unit may only be carried out after **prior consultation at SIEB & MEYER**.

### 4.2 Appropriate Use

Since the servo amplifiers are electronic equipment, used for the operation of motors and provided for the installation into machines, the safety considerations of the **machine guidelines (89/392/EEC)** must be paid attention of.

**Before** setting to work, make sure that the machine will not expose danger (e. g. runaway moves) and the instructions of the machine guidelines are fulfilled. **The conformity according to the EN 60204-1 must have been checked.**

The manufacturer of the plant or the machine has to meet the requirements of the legislation regarding the **electromagnetic compatibility (EMC)**.

This series of servo amplifiers has been designed that they meet the requirements of the standard. They can be operated in **industrial areas**, provided the attached EMC information has been taken into consideration and a **SIEB & MEYER mains filter of series 011.00.3x** for a 3-phase operation in different designs or **011.00.10** to **011.00.13** for a one-phase operation. As a standard motor filters, for example, are installed in this series.

SIEB & MEYER takes care in its own EMC laboratory over their products to meet the respective standards, when they are installed properly.

The servo amplifier meets the **requirement of the low-voltage guideline (73/231/EEC)**. The coordinated standards of the series **DIN EN 60 204** in combination with **DIN EN 60 439 - 1** and **DIN EN 60 947** are used for the servo amplifiers.

The technical data and the connection specifications can be found in the manual.

### 4.3 Transport and Storage

Make sure, that the amplifier is correctly used. The following points must be especially taken into consideration:

- ▶ Mechanical damage due to the transport or handling
- ▶ Dirt and humidity
- ▶ Contact with electronic components (electrostatic discharge)
- ▶ Modification of isolating distances
- ▶ Dry and well-ventilated storage area.
- ▶ No storage in the open.
- ▶ Storage temperature between -25°C and +55°C (shortly +70°C).

### 4.4 Installation

- ▶ The servo amplifier can be loaded to its maximum up to a height of 1,000 m M.S.L.
- ▶ For an operation in areas higher than 1,000 m M.S.L. the capacity must be reduced by 15 % per 1,000 m.
- ▶ The ambient air must not contain aggressive, electrically conductive or easily inflammable substances and should contain least dust.
- ▶ The admissible relative humidity is approx. 95 % (no bedewing).
- ▶ The admissible ambient temperature during the operation is between 5° C and 40°C. At temperatures > 40° C the capacity must be reduced by -1,5 % per °C.
- ▶ Pay attention that the fans installed in the amplifier have sufficient space to take in and exhaust the cooling air.
- ▶ Do not touch electronic components. The servo amplifier contains electrostatically endangered components that may easily be damaged by improper handling.

## 4.5 Electrical Connection

The valid rules for prevention of accidents (e. g. VBG 4) should be paid attention of, when working at current-carrying servo amplifiers.

The electrical installation has to be carried out according to the relevant instructions (e. g. line cross section, fuse protection and connections of ground conductors).

Recommendation for the installation according to the EMC, like for example the shield, grounding and line installation, can be found in this chapter of the servo amplifier manual. The manufacturer of the plant or machine has to meet the requirements of the legislation regarding the EMC.

- ▶ All work at and within the amplifier must only be carried out, when it is turned off.
- ▶ The mains line should only be connected, when the work is completed.
- ▶ Before turning on the amplifier the first time, make sure that the connected machine will not have runaway moves.
- ▶ After turning off the amplifier hazardous voltages may still exist for up to **3 minutes** due to capacities in the power supply.
- ▶ Capacitive loads must not be connected to the output phases of the servo amplifier.
- ▶ Prevent cable loops. Therefore, the servo amplifiers must **only** be grounded at the provided PE connection for the mains supply line and the 19" racks **only** at the provided ground screw.

In general, the operation can be made with residual current operated devices. Nevertheless, like all clocked units of the power electronics, also servo amplifiers can lead leakage currents via the ground system. Depending on the sensitivity of the residual current operated device and the installation type, the operation along with the device may arise problems. The following points should be taken into consideration:

- ▶ Use shortest motor leads possible.
- ▶ Do not connect additional consumers to the same residual current operated device.
- ▶ Use a residual current operated device with high response threshold.

## 4.6 Operation

Plants, into which the servo amplifiers are mounted, possibly must be equipped with additional protective devices according to the valid safety instructions (e. g. law about technical material, rules for prevention of accidents, etc.).

All doors and covers must be closed during the operation.

## 4.7 Maintenance

The amplifier, especially the fan, must be checked regularly for cleanness and function depending on the ambient pollution.

## 4.8 Guarantee

The guarantee is only granted when the points 4.1 to 4.7 are taken into consideration!

**The safety instructions must be kept!**

## 5 Installation Guidance to Meet Compliance With Electromagnetic Compatibility (EMC)

### 5.1 General Information

When integrating SIEB & MEYER units into larger installations, the following points should be considered to ensure compliance with the electromagnetic compatibility (EMC).

#### 5.1.1 Point 1

Ideally all metal enclosures should be seamless for maximum shielding integrity against radio frequency (RFI) and electromagnetic interference (EMI). All metallic surfaces should interconnect with the best conductivity to each other and to ground. With modular construction, adjoining metalwork should be assembled with plane surfaces wherever possible.

**Never rely on butted, painted or lacquered surfaces!**

Where necessary, use contact or scrape washers. Cabinet doors must be connected to the cubical frame with **short** multiple ground straps (top, center, bottom).

#### 5.1.2 Point 2

Low level signal lines<sup>1</sup> and power cables must be segregated to prevent cross coupling. A separation distance of at least 200 mm is recommended.

#### 5.1.3 Point 3

Signal lines<sup>1</sup> should be routed to connect with a unit from one side only and grouped flat, not bunched or crossed.

---

<sup>1</sup> Signal line definitions:

- digital signal, e. g. data transmission or feedback information signal lines
- analog signal, e. g. +10 V reference lines

## 5.1.4 Point 4

Unshielded balanced current circuits such as feed and return lines, should be wired as twisted pairs.

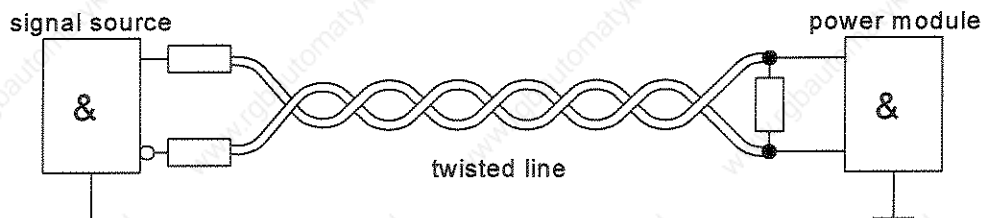

## 5.1.5 Point 5

Contactors and relays must be installed with both coil and contact suppression. The appropriate fitting of surge arrestors, resistor capacitor filters, varistors and diodes should be made to attenuate RF and EM interference.

Contacts should be fitted with parallel suppressors to limit interference generated when switching reactive loads.

Fit recovery diodes as close as possible across d.c. relay coils to limit radiation and protect circuitry from self-induced high energy transients.

## 5.1.6 Point 6

The shields of digital signal lines must be continuous and grounded<sup>2</sup>. Terminate the shield at source and receiver, using the **largest surface area and best conductive path** possible.

Submin D connectors with conductive shells must be used. The cable shield must be fully exposed to the strain relief grip.

Connecting short "pig tails" to cable shielding is outside EMC directives. This practice reduces shielding properties by approx. 70 %. Follow the guidance illustrated on the next page.

<sup>2</sup> All metallic surfaces should interconnect with the best conductivity to each other and to ground. Consideration must be given to central ground distribution and connections to cabinet housing, side panels, motor frames, trunking and all sub-assemblies.

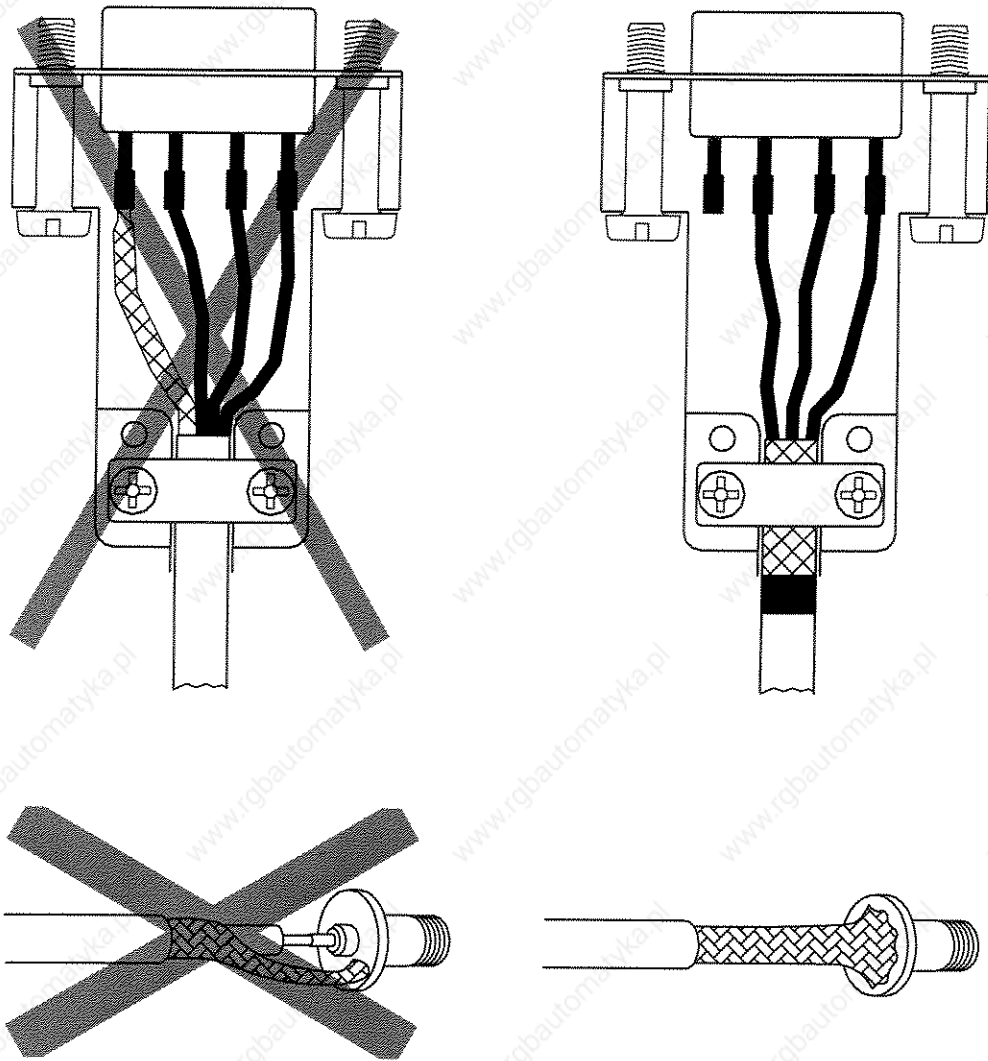

### Information about the shield fixing

If shielding properties or continuity through connectors is poor, a compensating line of at least 10 mm<sup>2</sup> must be added. Such a compensation line (braided ground strap is preferred) must be secured to the signal cable throughout its path.

## 5.1.7 Point 7

The shields of analog signal lines should only be grounded at one end only (**with largest surface and best conductivity!**). This prevents low-pass capacitance to source interference, the most common being induced by 50 Hz mains. Connect the shield at the S&M unit, where there is provision for this.

## 5.1.8 Point 8

If the fitting of specifically designed mains filter is essential, it must be mounted as close as possible to our unit and flat on the nearest ground plane (cabinet or structural metalwork). The ground connection should be substantial (at least 10 mm<sup>2</sup> cross section) and as short as possible (less than 50 mm). A copper ground strap is best suited or, the filter must be firmly bolted to the ground plane.

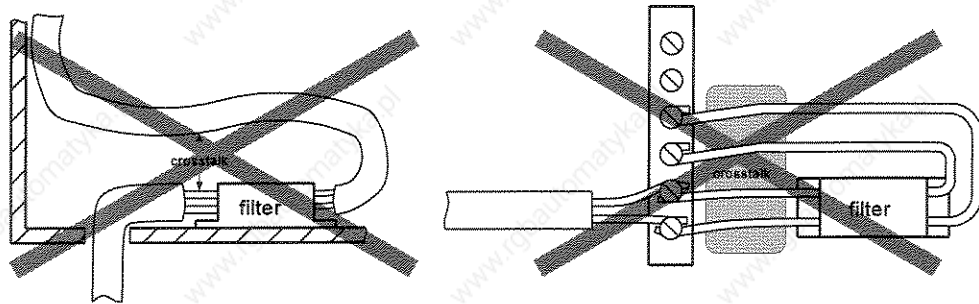

incorrect filter mounting

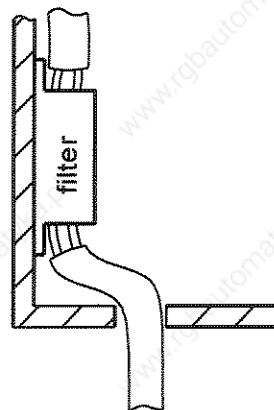

correct filter mounting

Input and output wiring must be segregated or cross coupling could nullify the filter effectiveness.

If a cabinet contains only one significant interfering component, for example one servo amplifier among several low level control units, it is recommended to fit a filter directly at this source. The differential-mode current is now only present beyond its source, (the amplifier) and the common-mode interferences are blocked. This mitigates all internal radiation, ensuring the adjacent control units are subjected to minimal interference.



The figure below shows an example of a S&M filter, directly screwed on the side panel of the servo amplifier. A direct low-impedance connection between side panel of the servo amplifier and filter ground plane is now made by a bolt in the filter design. The green-yellow PE wire is redundant and should be omitted to prevent a further common-mode path.

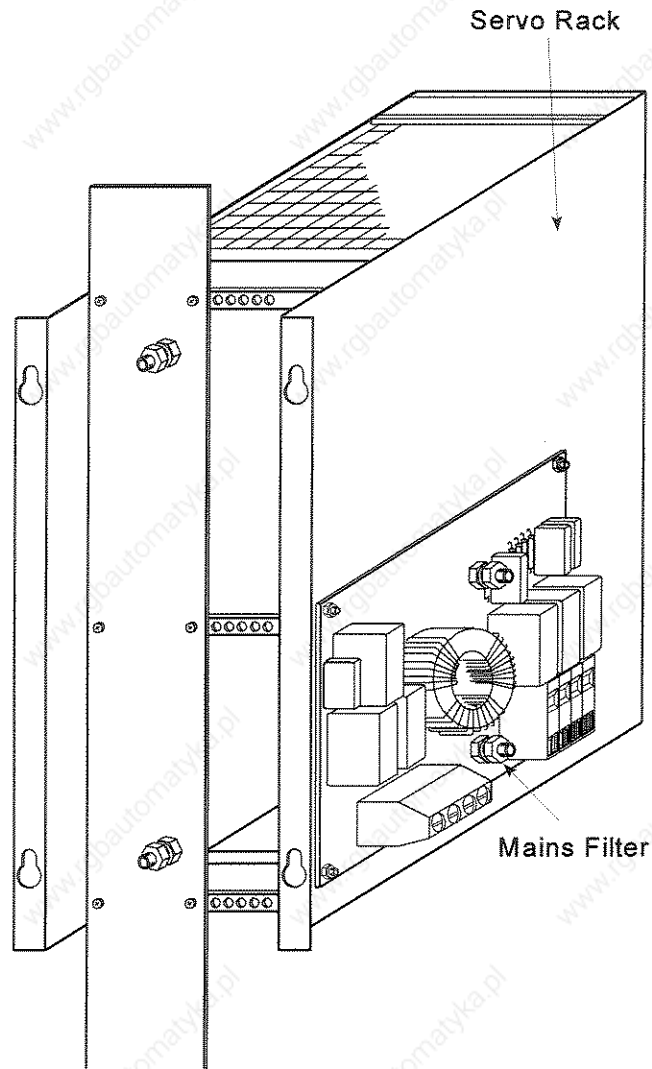

## 5.1.9 Point 9

To ensure compliance with Point 2, do not wire haphazardly. Use disciplined routing, with cables regularly secured close to the cabinet ground plane or the unit in question.

Unused cable "spares" must be grounded. The best practice is to ground both ends as this enhances the properties of the cable shield.

The ground lines connecting chassis and cabinet must be at least 10 mm wide and as short as possible. Avoid unnecessary loops to minimize radiation propagation effects.

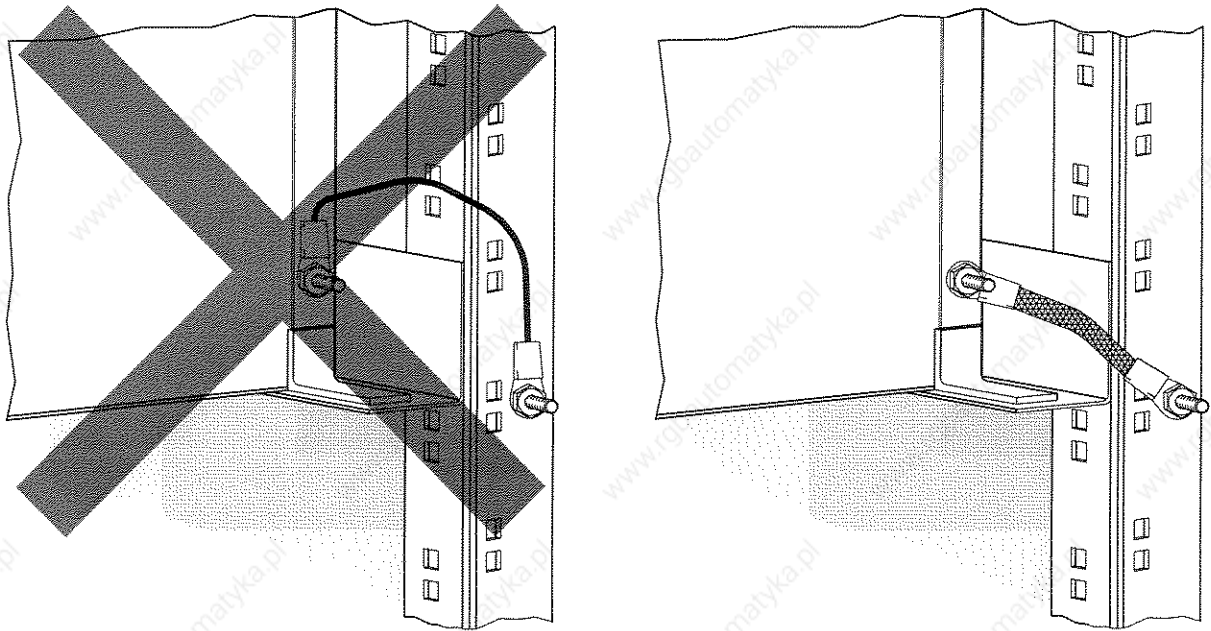

### Annotation to Points 8 and 9

**GREEN-YELLOW safety PE ground wires are unlikely to fully comply to EMC requirements. To obtain the high frequency properties required EMC ground conductors must be as short and wide as possible.**

## 5.1.10 Point 10

Avoid unnecessarily long wires to keep RFI and EMI radiation coupling low.

Consideration must be given to all wiring in the vicinity of grounded enclosures and back planes, etc.

Wiring technique for asymmetric signals on a PCB.

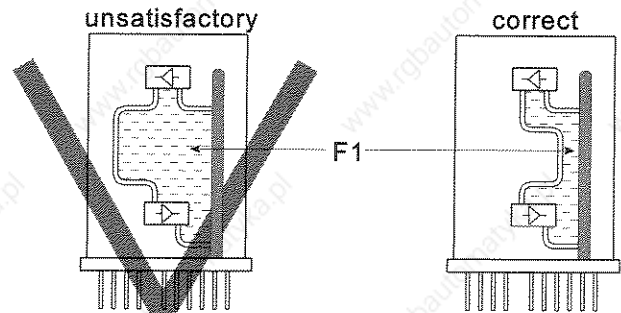

Wiring technique for symmetric signals in the unit.

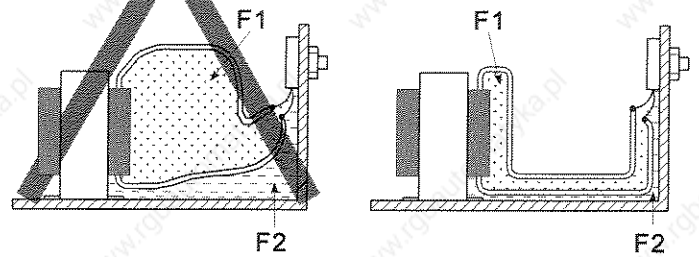

**Reduction of the current loop "F" field area lowers interference (both as source and sink)**

Exercising this point will ensure the equipment's transmitted radiation is reduced and its tolerance to extraneous interference is enhanced.



## 5.1.11 Point 11

When feeding a cable into the cabinet, the shield should be connected directly at the cabinet transition. Use the largest shield surface area possible and avoid laying off using "pig tails".

The best way to ensure shielding integrity is to fit a propriety shield bar, which will offer the best connections to a collective ground point.

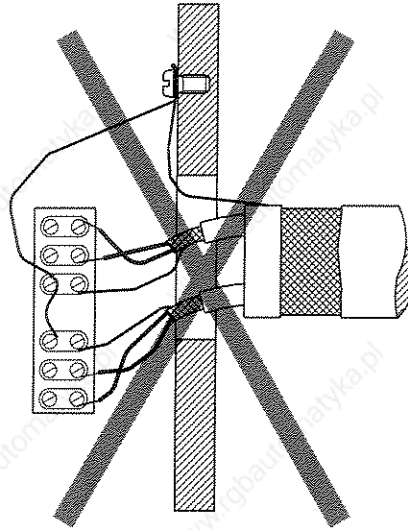

connect with best conductivity and with largest surface to both cabinet sides!

shield connection, e. g. Bettermann mounting clip

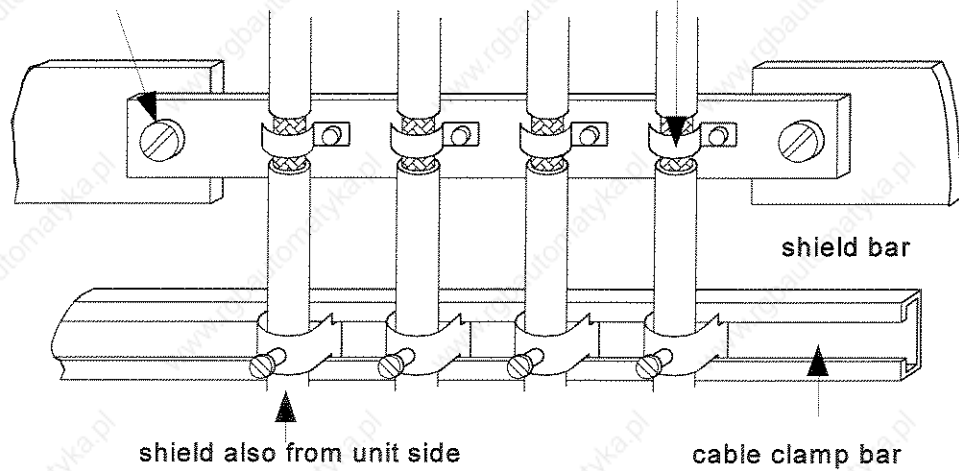

**Shield at cabinet transition**

## 5.2 Conclusion

Finally some rules are explained using a S&M cabinet as an example. The cabinet element numbered correlate to the relevant points in the guidance.

In the example shown a chrome-plated bearer mounted lower right in the cabinet serves as the central ground. From this star point grounds such as (1) mains filter, shield bar and chassis ground planes, are connected using the largest surface area possible.

(2) shows that cables must be installed with full consideration to their purpose. The voltage supply lines are best installed from bottom to top, secured on the center of the right cabinet panel. Motor and control lines are secured and channeled along separate paths from the shield bar to the servo amplifiers by cable bars. Flat cable forms connecting the bottom plate to the CNC controller, are installed together on the center of the left cabinet panel (2 + 3).

Mains filters should be mounted as close as possible to the major

interfering unit, or nearest the central ground point and mains cable cabinet transition (8). Pay particular attention to ensure that the filter ground line is installed with the lowest of impedance possible. In the example shown (8) the filter ground plane has a large surface area contacting the chromium-plated central ground point (1).

Use short and wide braiding straps for further grounds, like those with chassis and door (9).

At the cabinet transition or unit lead-in, each shielded cable should be connected with its shield to a shield bar (11). This offers the best condition to the central ground point.

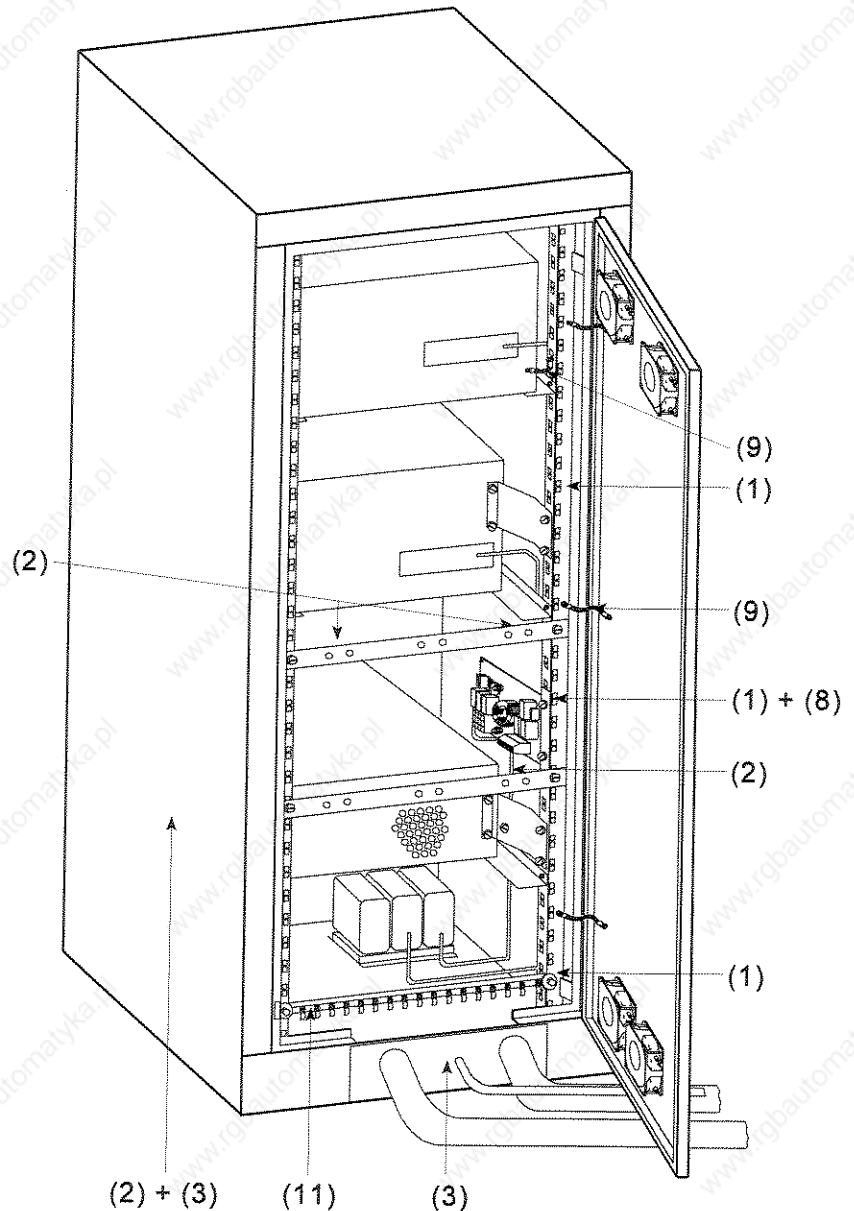



## 5.3 Annotation

These recommendations should help an installer realize EMC compliance. However, the points raised are intended for guidance and not as the definitive criteria of EMC directives. SIEB & MEYER trust this installation guide is of assistance, but cannot accept liability for any omission or problems incurred meeting the EMC directives. This is because it is not possible for us to consider all the application and operational issues that are dependent on external wiring and the aggregate performance of other apparatus.

## 5.4 Literature

Elektromagnetische Verträglichkeit. Grundlagen, Analysen, Maßnahmen. Hrsg. Gonschorek, K. H./Singer, H. (Hrsg.) Stuttgart 1992 [B. G. Teubner Verlag, ISBN 3-519-06144-9]

Habinger, Ernst, Elektromagnetische Verträglichkeit. Grundzüge ihrer Sicherstellung in der Geräte- und Anlagentechnik. Heidelberg 1992 [Hüthig Buch Verlag, ISBN 3-7785-2092-X]

Durcansky, Georg, EMV-gerechtes Gerätedesign. Gestaltung störungsarmer Elektronik. Poing 1995, 4. Auflage [Franzis Verlag, ISBN 3-7723-5386-X]

Schwab, Adolf J., Elektromagnetische Verträglichkeit. Heidelberg 1994, 3. Auflage [Springer Verlag, ISBN 3-540-57658-4]

Geräte- und Anlagentechnik. Jeromin, G./ Schmidt, V. (Hrsg.) DEMVT Deutsche Gesellschaft für EMV-Technologie e. V., Chiemseestr. 21, 83022 Rosenheim

EMV elektronischer Geräte. Garn, H. (Hrsg.) DEMVT Deutsche Gesellschaft für EMV-Technologie e. V., Chiemseestr. 21, 83022 Rosenheim

## 5.5 Connections Between Machines and Power Modules Meet Compliance with EMC

Modern electronic control units, defined as PDS (power drive system) in EMC directives invariably use "switched mode" techniques to regulate AC and DC currents. Fundamentally any high frequency switching of currents may disturb other electronic equipment. However, many PDSs are working correctly without filters in the industrial environment without disturbing other apparatus. All filters reduce efficiency and, if used excessively, can only increase the size and expense of a PDS unit. Careful consideration is required to set limits to levels of emissions without incurring severe design penalties.

In our judgement the design of our control unit is the most appropriate. Within our units we block the major high-frequency currents with rejection filters to a degree that is economical viable. All PDS external wiring must minimize radiation by employing cable shields. Special attention must be made to the following, however.

### Example of an insufficient connection

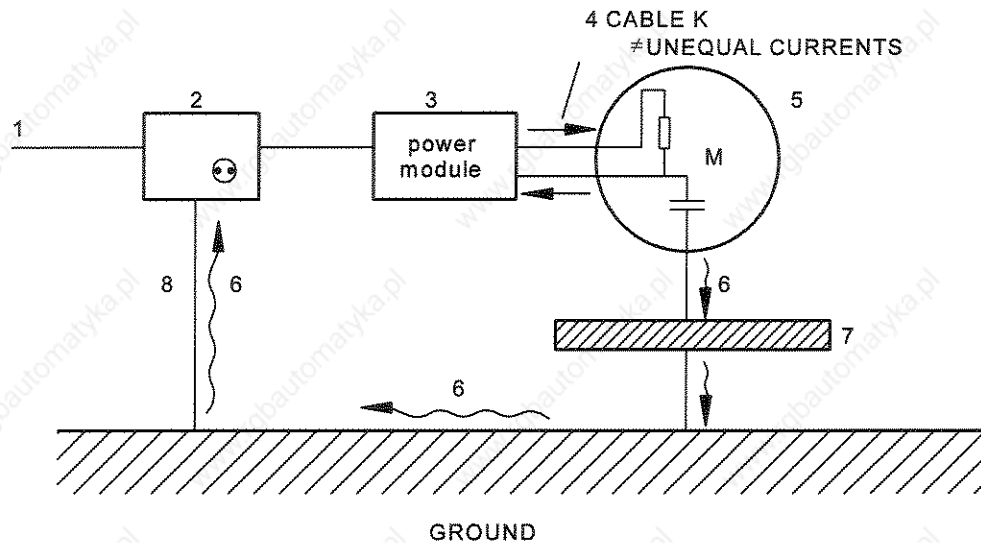

- 1 Mains connection
- 2 Artificial mains (standardizing impedance network)
- 3 Power module
- 4 Cable K (with unequal currents)
- 5 Motor
- 6 Undesired capacitive compensating current  $IK$
- 7 Machine base
- 8 Ground conductor (PE)

Theoretically, the sum of all the currents in cable K is equal to zero and no high-frequency radiation should result. However, this symmetry is lost by capacitively coupled current  $IK$ , which can create difficulties. Paths through fragmented surfaces may result in radiation and a path via the artificial mains network can reach the PDS and cause undesired effects.

The following will help:

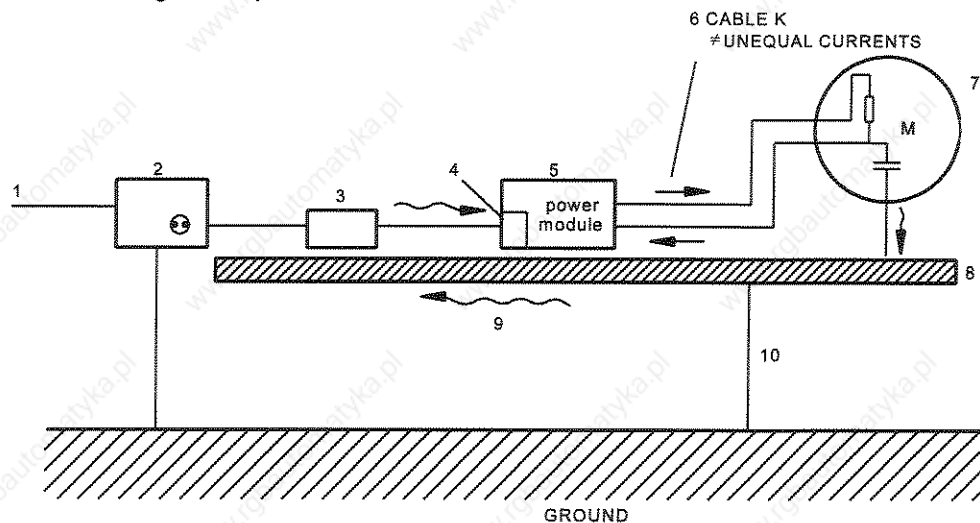

- 1 Mains connection
- 2 Artificial mains (standardizing impedance network)
- 3 SIEB & MEYER Surge Voltage Protection Device
- 4 Mains filter
- 5 Power module
- 6 Cable K (with unequal currents)
- 7 Motor
- 8 Machine base
- 9 Compensating current *LK*
- 10 Ground conductor (PE)

Additional information:

- ▶ The ground connection between machine and control unit must be as short as possible. Flat braided cable is best.
- ▶ The ground connection between filter and cabinet housing must be extremely short (50 mm is too long!).
- ▶ All shields must be connected using the largest continuous surface area.
- ▶ Classes of connection cables should be led to the machine as bunched for maximum mutual field support and only split there.
- ▶ The surge arrestor must be mounted within the confines of the machine.
- ▶ If a transformer is used, it should be connected between surge arrestor and filter (i. e., mains connection - arrestor - transformer - filter - control unit).
- ▶ The yellow-green safety ground wires offer full protection to VDE requirements. However, such connections offer poor impedance paths to high frequency. Full consideration must be given where good HF ground connections are desired, i. e., they must be short and connected through the largest surface area possible.
- ▶ When in doubt, please consult us. A sketch of your requirements can be most helpful in this matter.

If these rules are strictly used, the machines and the control unit will meet the limiting values of the standard DIN/EN 61800-3: 1996-7. To verify the compatibility we check our PDS units in a test configuration simulating machine and wiring. The simulation consists of a sheet metal plate with the ground capacity and impedance loadings to simulate the equivalence of an average size machine. An acknowledged testing laboratory has verified it is representative and suitable for our periodic compliance measurements.



## 5.6 Used Standards

We have used the EMC Product Standard PDS (Power Drive Systems) DIN/EN 61800-3 of July 1996, which takes into consideration the contents of the following generic standards:

### Immunity

- ▶ EN 50 082-2 Generic Standard Immunity, Industrial Estates
- ▶ EN 60 801-2 Immunity Against Unloading of Static Electricity (ESD)
- ▶ EN 60 801-3 Immunity Against Electromagnetic Fields
- ▶ EN 60 801-4 Immunity Against Fast Transient Disturbances (BURST)
- ▶ EN 60 801-5 Immunity Against Surge Voltages (SURGE)

### Interfering Radiation

- ▶ EN 50 081-2 Generic Standard Interfering Radiation
- ▶ DIN/VDE 0877, Part 1, Measuring of Radio Interferences / Terminal Voltages
- ▶ DIN/VDE 0877, Part 2, Measuring of Radio Interferences / Radio Interference Intensity
  - The use of mains filters is indispensable to obtain the conformity according to the DIN/VDE 0877, Part 1 (Measuring of Radio Interferences). Our SM Mains Filters of Series 011.xx.xx have especially been designed for this purpose.
  - An overvoltage protection unit must be superposed to fulfil the conditions of intensity 4 or higher (not required) of EN 60 801-5 (Immunity Against Surge Voltages). The SM Protecting Device Against Surge Voltage of Series 011.00.5 provides reliable protection.

#### Note

**Separate limit values of the EMC Product Standard and of the Generic Standards may deviate!**

## 6 Mechanical Mounting

The modules of the compact system are integrated in a shortened chassis for wall-mounting. They can also easily be replaced by unscrewing the stop screws.

- ▶ After inserting the modules, it is indispensable to firmly fasten the stop screws. Otherwise, a secure contact of the plug-in connectors will not be given. An insecure contact to the back plane can damage the plug-in connectors!
- ▶ The modules must only be replaced, when the lines are **dead!**

### Important Information

- ▶ Above and below the chassis at least a space of 10 cm must be provided to ensure sufficient cooling.
- ▶ The modules have a very compact design. We recommend using extraneous fans for the servo modules to prolong the life expectancy and keep the efficiency of 100 % at an ambient temperature of up to 60 °C.
- ▶ The life expectancy of an electrolytic capacitor integrated in the amplifier, for example, is defined as below:
 

|   |          |               |
|---|----------|---------------|
| > | 40 °C =  | 100,000 hours |
| = | 85 °C =  | 4,000 hours   |
| = | 105 °C = | 1,000 hours   |

Thus, a reduction of  $\Delta\theta = 10^\circ\text{C}$  doubles the life of the electrolytic capacitor.

## 6.1 Module Replacement

The servo module has no control elements. The operation is made

- ▶ via external control elements or
- ▶ by higher-ranking intrasystem controllers.

### Attention!

**When using the servo modules in manipulators and machines, uncontrolled moves of the drive motors may be caused due to internal or external interference or inappropriate operation and wiring. Therefore, observing all safety instructions is indispensable in order to preclude any injuries and damages to machines.**

A complete rack can easily be replaced due to the strictly modular design of the SIEB & MEYER modular servo systems.

### Instruction

**Only replace any racks, when they are deenergized.**

All component sockets are on the right-hand board (logic card), viewing from the front panel.

In order to ensure that in the new installed module the same logic components are operative, just take the component carriers from the dismantled module and put them into the module to be installed. In addition, check the jumper assignments.

In case of any failure of a module, the service can normally be limited in replacing the faulty modules. Please note that the rack of the new module can be installed **only when deenergized**.

## 7 Wiring

### 7.1 General Information

The conductor cross sections should be selected carefully, so that the max. admissible current is not exceeded at the max. ambient temperature (the max. ambient temperature of the servo module is 60°C). The admissible values for the separate cross sections are defined in the VDE guidelines VDE-0100 T523.

The conductor cross section is directly connected with the max. admissible current.

| Conductor Cross Section<br>[mm <sup>2</sup> ] | Admissible Current<br>[A <sub>eff</sub> ] |
|---|---|
| 0,75  | 12  |
| 1,00  | 15  |
| 1,50  | 18  |
| 2,50  | 26  |
| 4,00  | 34  |
| 6,00  | 44  |
| 10,00   | 61  |
| 16,00   | 82  |
| 25,00   | 108                                       |
| 35,00   | 135                                       |
| 50,00   | 168                                       |

max. ambient temperature 30°C

### 7.2 Motor Cables

Use shielded conductors for the motor to keep the interferences low as possible (conductor cross section according to the table).

### 7.3 Cables for Rotary Encoders

Use shielded conductors for the wiring of the different rotary encoders. For motors with an integrated resolver the cable must additionally be twisted.

- ▶ Motors with resolver  
LICYC 3 × 2 × 0,14 or 4 × 2 × 0,14 for motors with integrated thermal contact.  
Shielded, pairwise twisted conductors. Twist mode: sine/sine, cosine/cosine, rotor/rotor and, possibly thermal contact/thermal contact.  
For delicate applications we recommend to additionally shield the separate pairs.

## 7.4 Wiring of the *RPM Ref. Value*

The *RPM ref. value* is led to the PI speed regulators via a differential amplifier. This type of evaluation has been chosen due to obtained accuracy of the ref. value, which is a main criterion for the optimal function of the RPM regulator. In this way the differential amplifier counteracts interference voltages that, for example, can be caused from grounding problems between position controller and servo module.

### Wiring of the *RPM Ref. Value* (controller has one output)

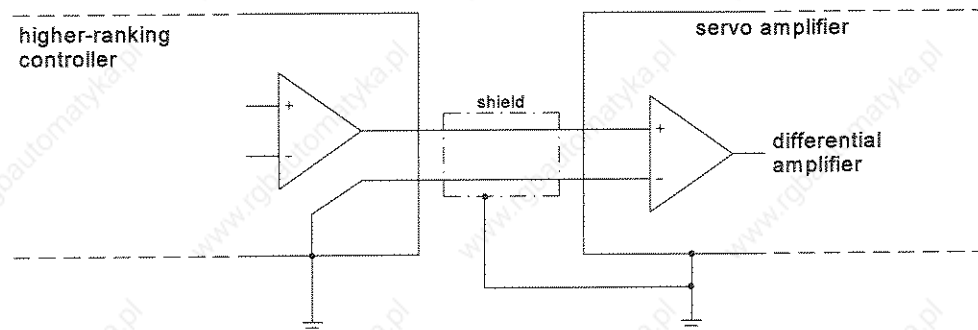

The example shows that the ref. value must be led to the differential amplifier of the servo module via two conductors. The negative ref. value input must be grounded in the higher-ranking position controller. LICYC 1 × 0.14.

### Wiring of both *RPM Ref. Values* (controller has two outputs)

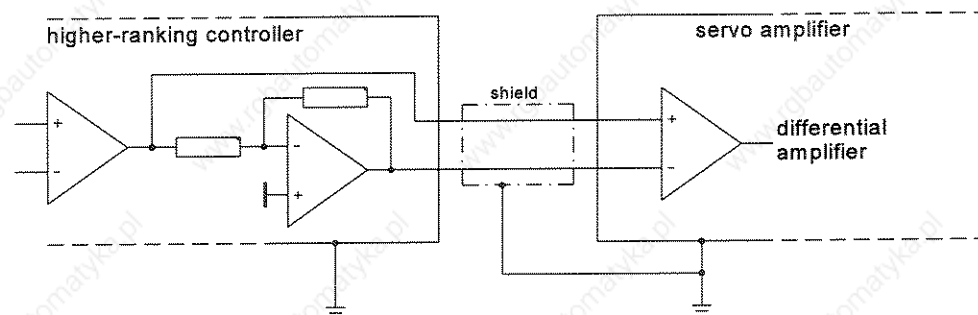

The example shows that both ref. values must be led from the higher-ranking controller to the differential amplifier of the servo module. LICYC 2 × 0.14.



## 7.5 Wiring of the Angle Pulses

Use shielded conductors for the wiring of the angle pulses, like for example LICYC 6 × 0.14.

For delicate applications we recommend using pairwise twisted conductors, possibly with an additional shield of the separate pairs. Twist mode:  $U_{a1}/\overline{U_{a1}}$ ;  $U_{a2}/\overline{U_{a2}}$ ;  $U_{a0}/\overline{U_{a0}}$ .

## 7.6 Mains Conditions

Before setting to work, check whether the following mains conditions prevail:

- ▶ Mains voltage 3 × 220 VAC ±15 % or  
Mains voltage 1 × 220 VAC ±15 %
- ▶ Does a power mains ground conductor exist?
- ▶ Is the mains frequency 50/60 Hz?

If these conditions are fulfilled, a transformer will not be required. In case of other voltages (e.g. 380 V mains voltage) the use of an autotransformer is sufficient, since the electronics supplies of the modules are isolated.

### NOTE

If mains overvoltages are to be expected, the input terminals of the power module (line-side) must be equipped with varistors (see also chapter "Accessories", section 'Overvoltage protection').

The terminal -UB of the intermediate circuit is only to be grounded when using an isolating transformer, since otherwise a motor ground connection cannot be detected.

### 7.7 Wiring Example

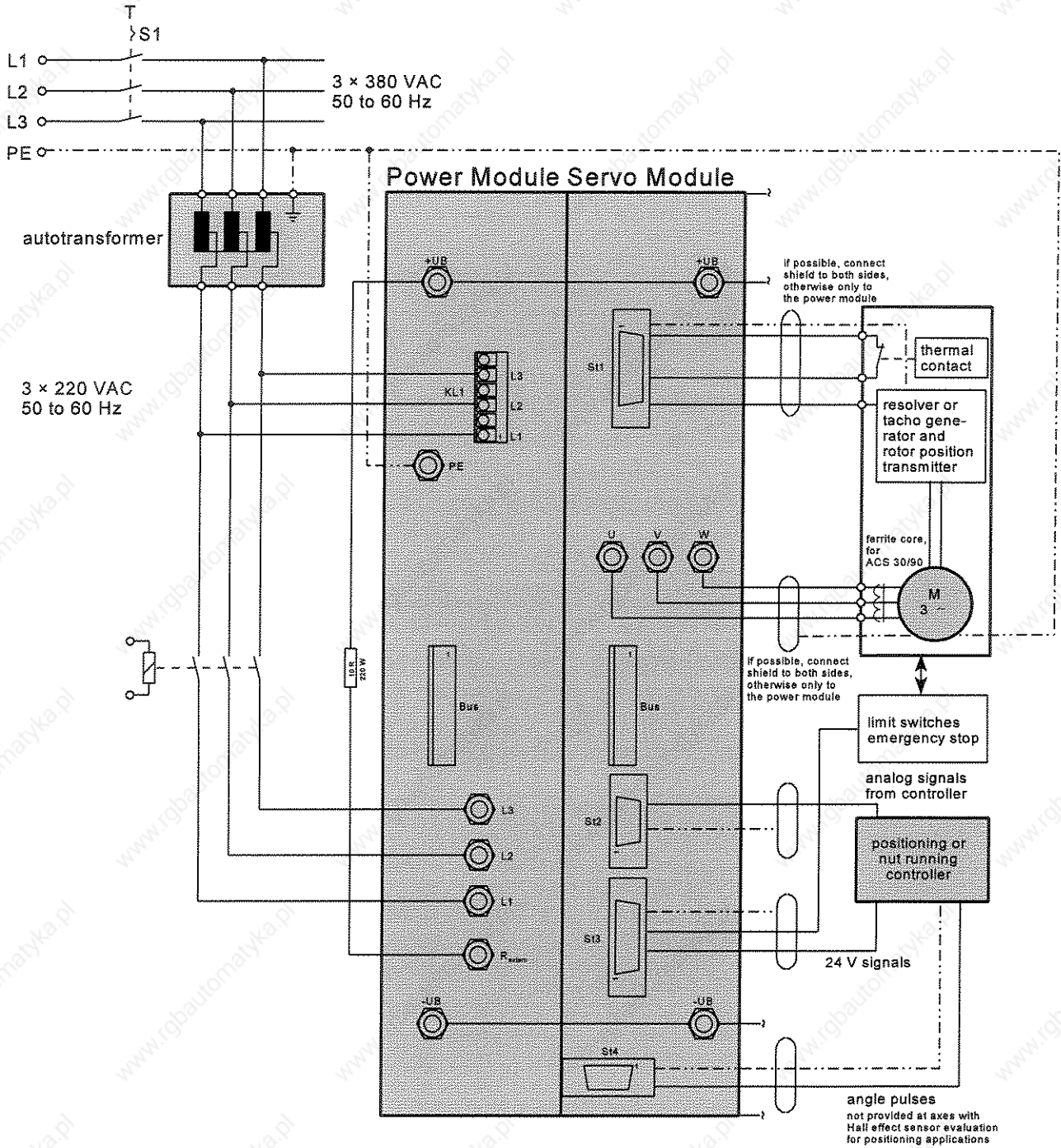

The example shows the wiring of a multi-axis servo amplifier. The wiring of the single-axis servo amplifier is identical, only the position of the connectors is different.



## 8 Single-Axis Amplifier for Positioning Applications

### 8.1 Front Panel of the Single-Axis Amplifier 26.39.2/31

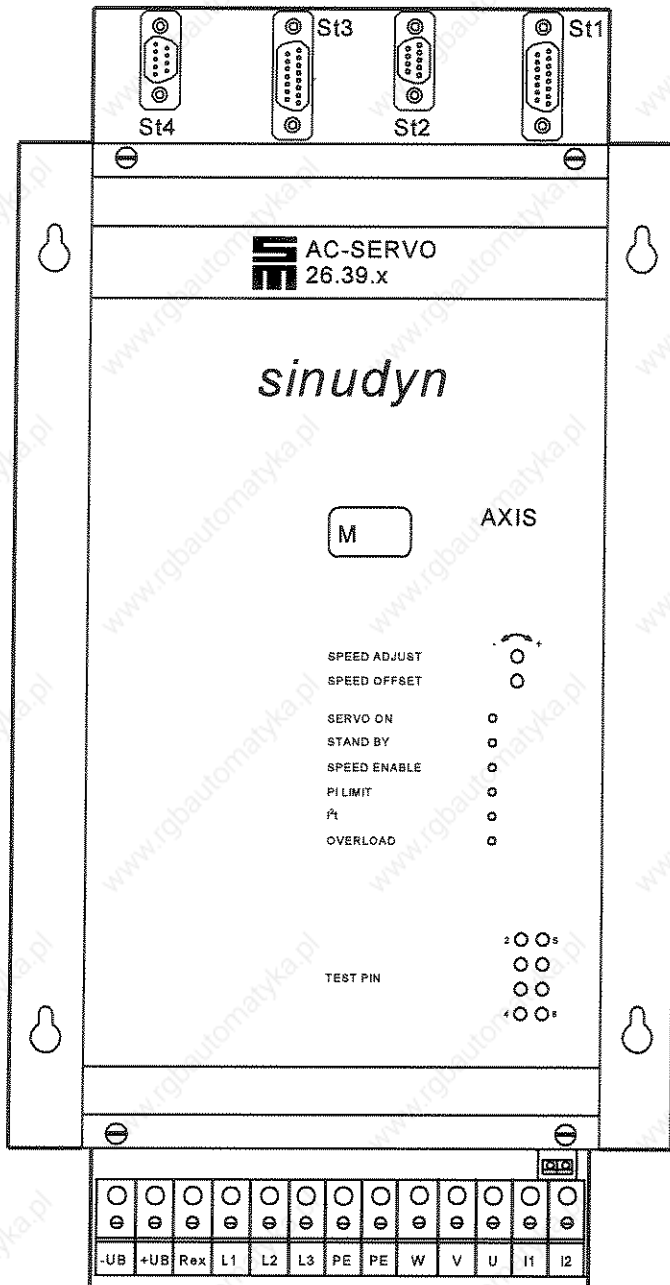

- St4 - angle pulses
- St3 - 24 V signals
- St2 - analog signals
- St1 - resolver

**Type designation** of single-axis amplifiers  
 x = 26.39.2 with logic card 26.39.046.1  
 = 26.39.31 with logic card 26.39.060.1

**M designation:** see chapter "General Information", section 'M Designation'.

**SPEED ADJUST:** Trimmer for precision adjustment of the actual RPM. The actual RPM has been preset in the factory and should only be modified in exceptional cases.

**SPEED OFFSET:** Trimmer for the drift compensation of the RPM regulator. See chapter "The Logic Cards", section 'Front Panel Potentiometers'.

**Test Pins:** Compare chapter "Operational Statuses of the System", section 'Test Pins at the Servo Module'.

Fan connection

13-pole terminal strip





## 9 Pin Assignment of the Amplifier 26.39.2/31

### 9.1 Terminal Strip

13-pole, max. 4 mm<sup>2</sup> conductor cross section

| Pin | Designation           | Explanation  |
|-----|-----------------------|--|
| 1   | -UB                   | intermediate circuit voltage<br>48 VDC, 100 VDC or 310 VDC $\pm 15\%$  |
| 2   | +UB                   |  |
| 3   | R <sub>external</sub> | external ballast resistor, 10 $\Omega$ /220 W. The resistor is wired between R <sub>external</sub> and +UB.  |
| 4   | L1                    | mains voltage<br>3 $\times$ 35 V, 3 $\times$ 72 V or 3 $\times$ 220 V $\pm 15\%$ , 50/60 Hz<br>or in case of a power consumption of < 2 kW<br>1 $\times$ 35 V, 1 $\times$ 72 V or 1 $\times$ 220 V $\pm 15\%$ , 50/60 Hz |
| 5   | L2                    |  |
| 6   | L3                    |  |
| 7   | PE                    | ground conductors  |
| 8   | PE                    |  |
| 9   | W                     | motor phases   |
| 10  | U                     |  |
| 11  | V                     |  |
| 12  | I1                    | mains voltage for the logic voltage and for the fans, 35 V, 72 V or 220 V $\pm 15\%$ (must always be connected!).  |
| 13  | I2                    |  <i>Make sure, that the same phases are connected to pins 4 and 12 resp. 5 and 13. See next page.</i>                                 |

## 9.1.1 Mains Input for the Main Supply

The main supply must always be made via the inputs at pins 4, 5 and 6.

| Pin assignment for the main supply |                   |                      |
|------------------------------------|-------------------|----------------------|
| pin                                | 3-phase operation | 1-phase operation    |
| 4                                  | phase L1          | phase L1             |
| 5                                  | phase L2          | neutral conductor Mp |
| 6                                  | phase L3          | free                 |

The mains power supply is made via the Pins 4, 5 and 6. The ground conductor (PE) is put on pin 7 or 8 resp.

 *If the rated capacity of the system is smaller or equal  $P = 2$  kW, also single-phase can be supplied.*

If necessary, an autotransformer can be used, since the voltage supply for the inputs of the internal controller is separated galvanically from the mains.

## 9.1.2 Mains Input for the Logic Voltage

Via pins 12 and 13 the logic voltages of 24 V,  $\pm 14$  V and 5 V are supplied independently of the intermediate circuit voltage. Thus, the intrasystem logic is ready for operation already before the turnon of the main supply, so that all signals and messages are available for the user right from the start.

| Pin assignment for the logic voltage supply |                   |                      |
|---|-------------------|----------------------|
| pin   | 3-phase operation | 1-phase operation    |
| 12  | phase I1          | phase I1             |
| 13  | phase I2          | neutral conductor Mp |

### Note

The input phases of pins 12 and 13 and the connection phases of the main supply, pins 4 and 5, must be identical.



## 9.1.3 Wiring Main Supply with Logic Voltage Supply

| Pin Assignment 3-Phase Operation |            |   |               |     |
|----------------------------------|------------|---|---------------|-----|
| Main Supply                      |            |   | Logic Voltage |     |
| Pin                              | Assignment |   | Assignment    | Pin |
| 4                                | phase L1   | ↔ | phase I1      | 12  |
| 5                                | phase L2   | ↔ | phase I2      | 13  |
| 6                                | phase L3   | ↔ | ---           | --- |

| Pin Assignment 1-Phase Operation |                      |   |                      |     |
|----------------------------------|----------------------|---|----------------------|-----|
| Main Supply                      |                      |   | Logic Voltage        |     |
| Pin                              | Assignment           |   | Assignment           | Pin |
| 4                                | phase L1             | ↔ | phase I1             | 12  |
| 5                                | neutral conductor Mp | ↔ | neutral conductor Mp | 13  |
| 6                                | free                 | ↔ | ---                  | --- |

After assigning Pins 12 and 13, the main supply at Pins 4, 5 and 6 must only be turned on, when the motor shall rotate.

### Note

The mains input at pins 12 and 13 must always be connected. The angle pulses and error messages remain active in case of an EMERGENCY STOP situation. When the main power supply is turned off, make sure that all three mains phases are also turned off! For this reason use a main contactor with positively driven contacts.



## 9.2 Submin D Plugs and Connectors

### 9.2.1 St1 - Resolver

on the board: 15-pole Submin D female connector  
 counter plug: 15-pole Submin D male connector

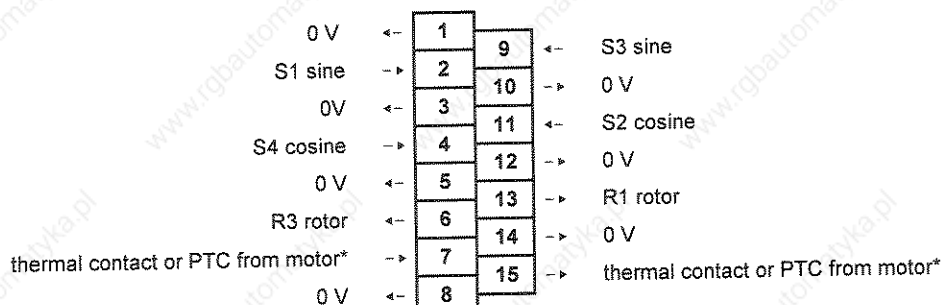

\* If no thermal contact is connected, a strap must be put between Pins 15 and 7.

Use screened conductors, 3 × pairwise twisted. Twist mode: sine/sine, cosine/cosine, rotor/rotor; designation of the conductor, e. g. LIYCY 3 × 2 × 0,14.

Put shield on 0 V potential.

Evaluation of the thermal contact in chapter "The Logic Cards", section 'Jumper Assignments'.

### 9.2.2 St2 - Analog Signals

on the board: 9-pole Submin D male connector  
 counter plug: 9-pole Submin D female connector

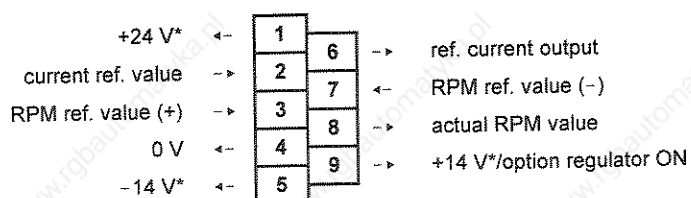

\* for test purposes only!



## 9.2.3 St3 - 24 V Signals

on the board: 15-pole Submin D male connector  
counter plug: 15-pole Submin D female connector

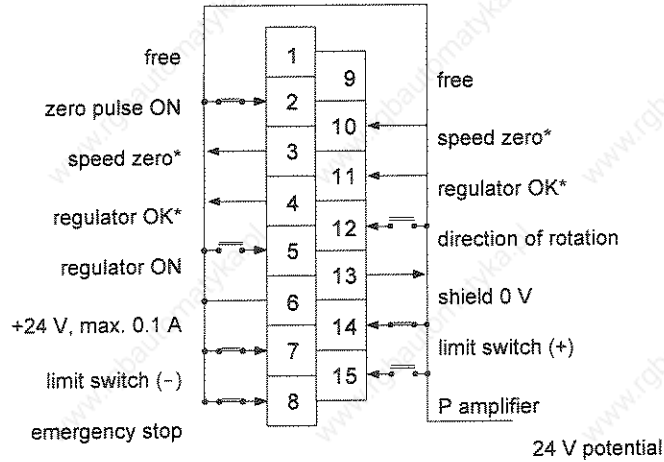

\* volt-free contacts

All **inputs** work with a voltage of +14 V to +24 V.

## 9.2.4 St4 - Angle Pulses

on the board: 9-pole Submin D female connector  
counter plug: 9-pole Submin D male connector

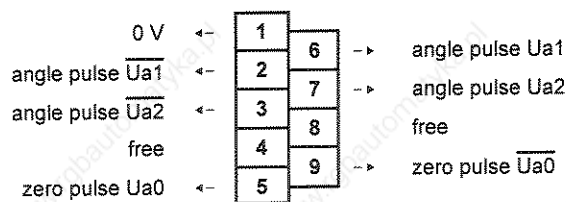





---

# The Logic Cards

|   | page |
|---|------|
| <b>1 General Information</b> .....                                  | 1    |
| 1.1 Equipment of the Component Sockets .....                        | 1    |
| <b>2 Servo Module for Positioning Applications</b> .....            | 3    |
| 2.1 Layout Plan Logic Card 26.39.046.1 .....                        | 3    |
| 2.2 Layout Plan Logic Card 26.39.060.2 .....                        | 5    |
| <b>3 Sockets of Logic Cards</b> .....                               | 7    |
| 3.1 Socket S1 - Current Control .....                               | 7    |
| 3.2 Socket S3 - Resolver .....                                      | 7    |
| 3.3 Socket S5 - EPROM .....   | 8    |
| 3.3.1 Resonance Filter .....  | 9    |
| 3.4 Sockets S6 and S7 - System Motor Specifications .....           | 10   |
| 3.4.1 Tacho Adjustment .....  | 10   |
| 3.4.2 RPM Regulator Adjustment .....                                | 11   |
| <b>4 Jumpers of Logic Cards</b> .....                               | 13   |
| 4.0.1 Jumpers 1 and 2 - Phase Shifting .....                        | 13   |
| 4.1 Jumpers 3 to 6 - Number of Zero Pulses .....                    | 14   |
| 4.2 Jumpers 7 to 20 - Number of Angle Pulses .....                  | 15   |
| 4.3 Jumpers 21 and 22 - RPM .....                                   | 16   |
| 4.4 Jumpers 23 and 24 - Angle Pulse Count Mode .....                | 16   |
| 4.5 Jumpers 25 and 28 - Thermal Protection Function .....           | 17   |
| 4.6 Jumpers 29 and 30 - Malfunction .....                           | 18   |
| 4.6.1 Evaluation of the Thermal Contact .....                       | 19   |
| 4.7 Jumpers 31 and 32 - Current Ref. Value Preset .....             | 19   |
| 4.8 Jumpers 33 and 34 - Tacho Filter Characteristics .....          | 19   |
| 4.9 Jumpers 35 and 36 - Activation of the Position Controller ..... | 20   |
| <b>5 Rotary switch</b> .....  | 21   |
| <b>6 Hook Switches for Zero Pulse Shifting</b> .....                | 22   |
| <b>7 Front Panel Potentiometers</b> .....                           | 23   |
| 7.1 SPEED ADJUST .....  | 23   |
| 7.2 SPEED OFFSET .....  | 23   |







# 1 General Information

## 1.1 Equipment of the Component Sockets

The allocation of the drive specific control parameters is made by the corresponding equipment of the component sockets. These are arranged easily accessible on the plug-in type logic card.

All component sockets are arranged on the right-hand board (logic card).

The servo modules are supplied and adjusted according to the data known to SIEB & MEYER. The equipment values can be seen in the User Specific Data Sheet.

By specifying the M designation remarked a ready adjusted replacement unit can be supplied at any moment within a short time.

The component sockets are equipped with different resistors and capacitors. The designation of these components depends in the numbering mode on the socket and pin assignments and is CSxy or RSxy; x = Socket number, y = Pin number.

**Before changing any parameters, please contact factory for information.**





## 2 Servo Module for Positioning Applications

### 2.1 Layout Plan Logic Card 26.39.046.1

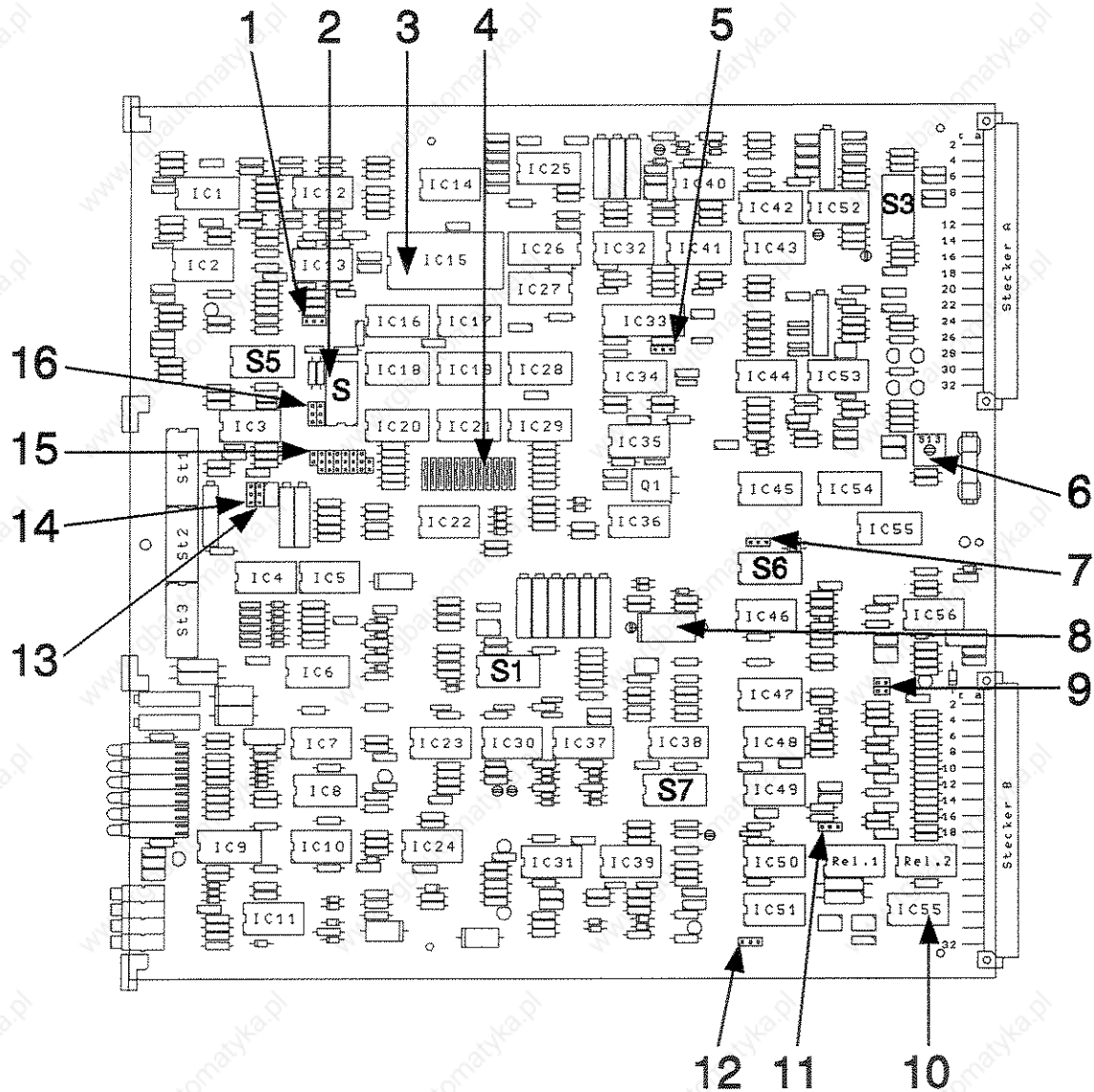

- 1 Jumpers 1 and 2 – phase shifting
- 2 Socket for zero pulse setting device
- 3 EPROM
- 4 Hook straps for zero pulse adjustment
- 5 Jumpers 23 and 24 – angle pulse count mode
- 6 Rotary switch
- 7 Jumpers 25 to 28 – thermal protective function
- 8  $I^2t$  electrolytic capacitor
- 9 Jumpers 35 and 36 – activation of the position controller
- 10 Output IC for angle pulses
- 11 Jumpers 31 and 32 – current ref. value preset
- 12 Jumpers 29 and 30 – malfunction behaviour
- 13 Jumpers 21 and 22 – RPM
- 14 Jumpers 33 and 34 – tachometer filter characteristics
- 15 Jumpers 7 to 20 – number of angle pulses
- 16 Jumpers 3 to 6 – number of zero pulses

# Positioning Applications/Resolver Evaluation

---





## 2.2 Layout Plan Logic Card 26.39.060.2

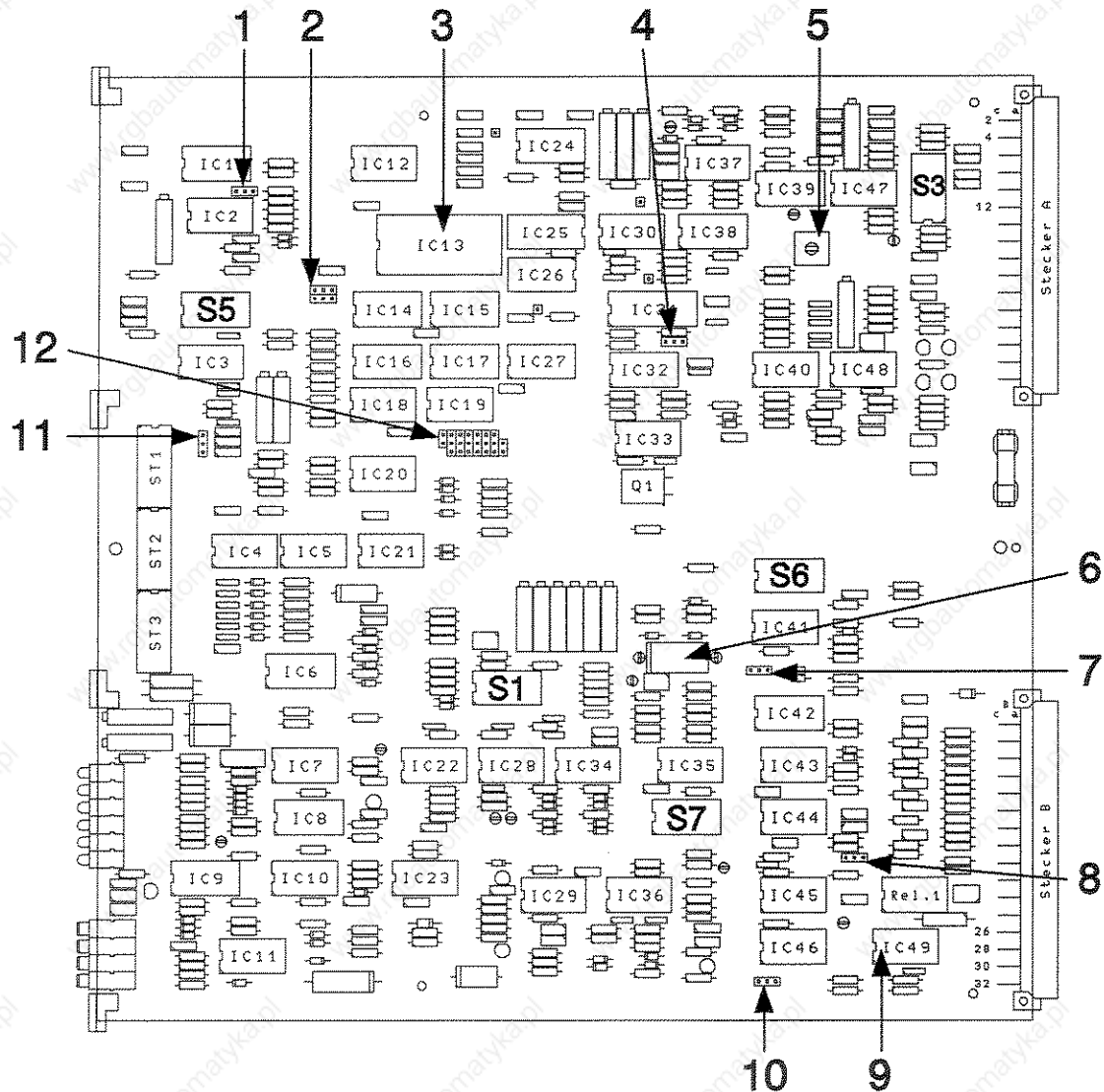

- 1 Jumpers 1 and 2 – phase shifting
- 2 Jumpers 3 to 6 – number of zero pulses
- 3 EPROM
- 4 Jumpers 23 and 24 – angle pulse count mode
- 5 Rotary switch
- 6  $I^2t$  electrolytic capacitor
- 7 Jumpers 25 and 28 – thermal protective function
- 8 Jumpers 31 and 32 – current ref. value preset
- 9 Output IC for angle pulses
- 10 Jumpers 29 and 30 – malfunction behaviour
- 11 Jumpers 33 and 34 – tachometer filter characteristics
- 12 Jumpers 7 to 20 – number of angle pulses





## 3 Sockets of Logic Cards

### 3.1 Socket S1 - Current Control

The components of socket S1 are assigned to the current control range. The different capacitors and resistor parameters affect the following PI data of the current regulator:

| pin    | component | function                      |
|--------|-----------|-------------------------------|
| 1 - 16 | ---       | free                          |
| 2 - 15 | ---       | free                          |
| 3 - 14 | CS 13     | current regulator I component |
| 4 - 13 | RS 14     | current regulator P component |
| 5 - 12 | RS 15     | current regulator P component |
| 6 - 11 | CS 16     | current regulator I component |
| 7 - 10 | ---       | free                          |
| 8 - 9  | ---       | free                          |

### 3.2 Socket S3 - Resolver

The components of socket S3 depend on the connected resolver. Since the optimal resolver choice is always motor specific, in case of replacing a resolver, ask for information for the adjustment from the factory.

The different resistor parameters affect the following system values:

| pin    | component | function       |
|--------|-----------|----------------|
| 1 - 16 | RS 31     | phase shifting |
| 2 - 15 | RS 32     | phase shifting |
| 3 - 14 | RS 33     | resolver input |
| 4 - 13 | RS 34     | resolver input |
| 5 - 12 | RS 35     | resolver input |
| 6 - 11 | RS 36     | resolver input |
| 7 - 10 | RS 37     | resolver input |
| 8 - 9  | RS 38     | resolver input |



## Positioning Applications/Resolver Evaluation

---

### 3.3 Socket S5 - EPROM

The components of socket S5 serve for adapting the EPROM and the resonance filter.

| pin    | component | function   |
|--------|-----------|--|
| 1 - 16 | RS 51     | resonance filter   |
| 2 - 15 | RS 52     | resonance filter   |
| 3 - 14 | RS 53     | VCO max. RPM   |
| 4 - 13 | RS 54     | VCO linearity  |
| 5 - 12 | RS 55     | logic card 26.39.046.1 - free<br>logic card 26.39.060.2 - phase shifting |
| 6 - 11 | RS 56     | gain resolver evaluation   |
| 7 - 10 | RS 57     | gain resolver evaluation   |
| 8 - 9  | RS 58     | compensation   |

 Resistors RS 56, RS 57 and RS 58 are factory adjusted and must not be changed.





## 3.3.1 Resonance Filter

An elastic coupling which might cause oscillation is at the drive shaft, can be suppressed by means of a resonance filter. To do so, the oscillation caused is to be determined at the actual RPM value, and for the frequency the following value results (measured at TP 5):

$$f = \frac{1}{T}$$

T = period of oscillation

The resonance filter is to be adjusted by means of the calculated resistors (see chapter "Assistance in Adjusting", section 'Calculation for socket S5').

### Important

A reoptimization of the RPM regulator must be made.

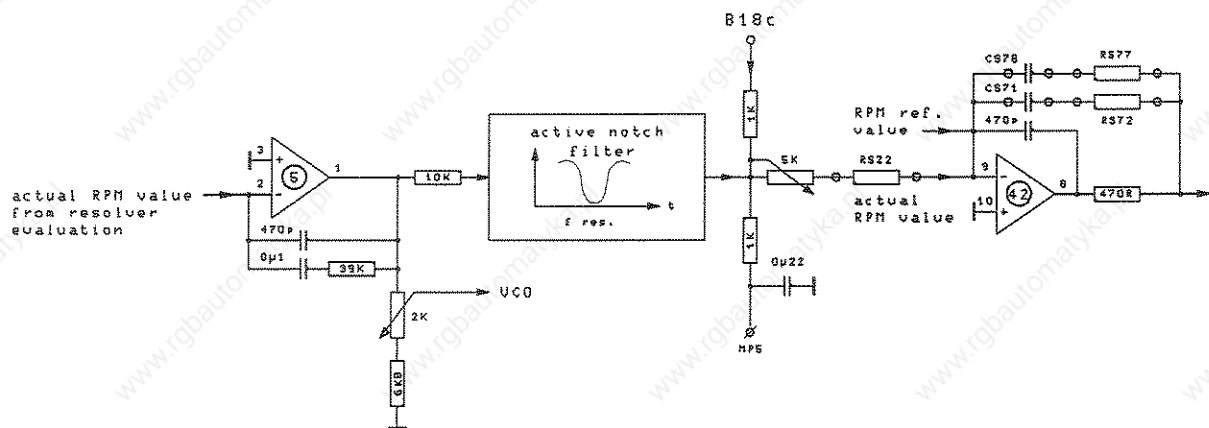

The resonance filter in control loop



### 3.4 Sockets S6 and S7 - System Motor Specifications

The components of sockets S6 and S7 are assigned to the system motor specification. The different capacitor and resistor parameters affect the following system values:

| socket S6 |           |   |
|-----------|-----------|---|
| pin       | component | function                                |
| 1 - 16    | RS 61     | peak current limitation                 |
| 2 - 15    | RS 62     | cooling temperature of the output stage |
| 3 - 14    | RS 63     | adjustment thermal contact              |
| 4 - 13    | RS 64     | $I^2t$ rated current                    |
| 5 - 12    | RS 65     | not equipped                            |
| 6 - 11    | RS 66     | not equipped                            |
| 7 - 10    | RS 67     | adjustment thermal contact              |
| 8 - 9     | RS 68     | $I^2t$ peak current                     |

| socket S7 |           |                           |
|-----------|-----------|---------------------------|
| pin       | component | function                  |
| 1 - 16    | CS 71     | RFI suppression           |
| 2 - 15    | RS 72     | RFI suppression           |
| 3 - 14    | RS 73     | tacho coarse resistor     |
| 4 - 13    | RS 74     | resistive D component     |
| 5 - 12    | RS 75     | RPM zero adjustment       |
| 6 - 11    | CS 76     | capacitive D component    |
| 7 - 10    | RS 77     | P component RPM regulator |
| 8 - 9     | CS 78     | I component RPM regulator |

Unless a M number for the drive has been assigned, the PI RPM regulator has a standard wiring according to the motor. The optimal adaptation can only be made at the complete drive. See "Determination of the PI RPM regulator circuitry", page 11.

#### 3.4.1 Tacho Adjustment

Three different RPM groups are available rated according to the revolutions, each up to 4,000 RPM, 8,000 RPM and 16,000 RPM. The max. motor RPM activated by feeding in the max. ref. value (see User Specific Data Sheet) is defined by RS 73. Precision adjustment can be made with the potentiometer *SPEED ADJUST* on the front panel.



## 3.4.2 RPM Regulator Adjustment

The following C and R components affect the PI regulator:

### CS 71 and RS 72

RFI suppression: This filter serves for smoothing the tacho signal and should not be changed.

### CS 78 and RS 77

Control module for the PI amplifier.

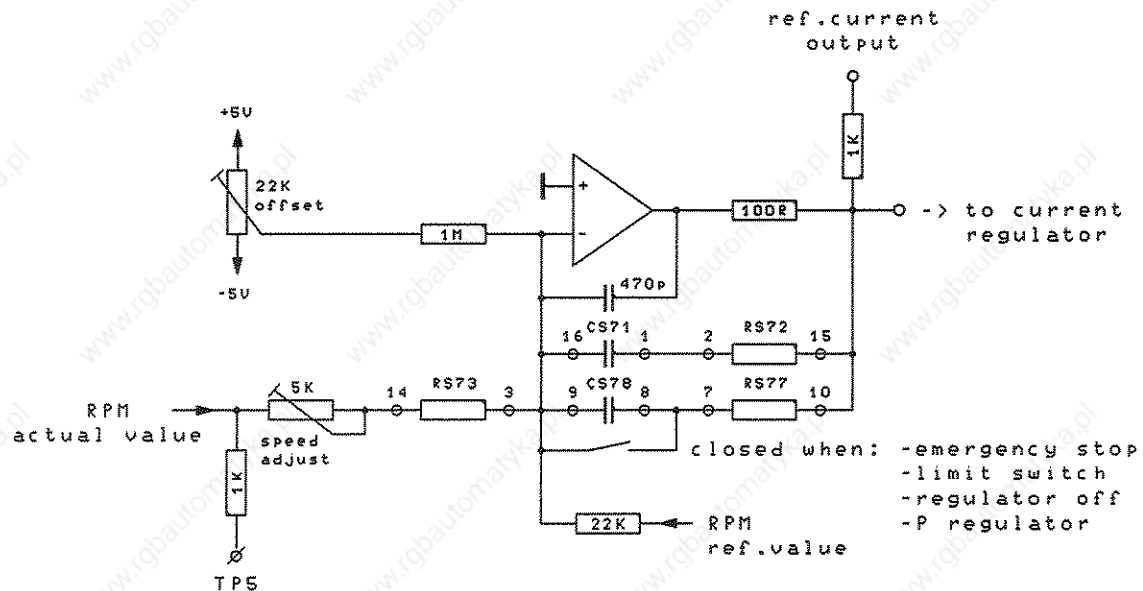

## Determination of the PI RPM regulator circuitry

The schematic diagram of the PI amplifier shows the components relevant for the optimization. The specific parameters as delivered can be found in the User Specific Data Sheet.

For optimization only some general rules can be given, since for instance the required time components depend on the characteristics of the machine axis and on the ref. value output by the internal controller.

A **higher P component** causes a harder reaction of the axis on ref. value changes; the oscillation tendency increases.

A **higher I component** damps the oscillation tendencies and causes a softer positioning of the machine axis in the intended position. The tendency toward mechanical overshooting, however, increases.

CS 78 produces the I component and RS 77 the P component of the PI regulator.

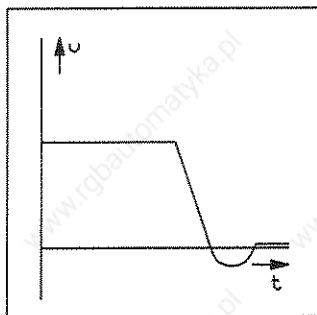

### PI setting ideal

If the step response of the system shows under-shooting and then a fast approximation to ref. value preset, the regulator circuit is ideal.

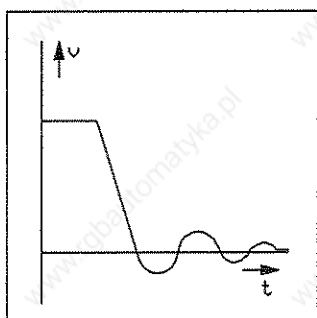

### PI setting too high

If a jump function is given to the system, the step response (measured at TP5) shows oscillation characteristics.

Remedy: reduce P component RS 77 or increase I component CS 78.

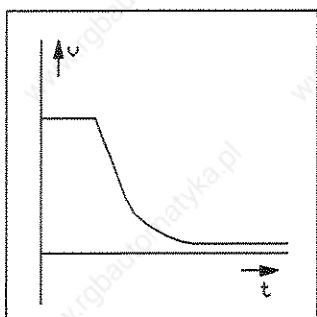

### PI setting too small

If the step response (measured at TP5) of the system has a very slow reaction (long time after reaching the RPM ref. value), the selected PI circuit is too small.

Remedy: increase P component or reduce I component.

Test jack TP5 on the front panel is a jack for the actual RPM value of the axis to be optimized.

## INSTRUCTION

If no optimal positioning characteristics is attained, check the drive rating and the load coupling.



## 4 Jumpers of Logic Cards

The jumper assignments required by the user can be found in the User Specific Data Sheet.



### Instruction

If no further specification is made, standard setting will be made in factory.

### 4.0.1 Jumpers 1 and 2 - Phase Shifting

These jumpers enable to attain a better utilization of the motor in the range of the max. RPM.

**Standard setting: phase shifting OFF**

| jumper position  | phase shifting |
|--|----------------|
| jumper 1  | ON             |
| jumper 2  | OFF            |

#### Logic card 26.39.046.1

The phase shifting is max. 30° and depends on current and RPM. The phase is shifted automatically.

#### Logic card 26.39.060

The phase shifting is max. 30°. The phase is defined via resistor RS 55 on socket S5.



# Positioning Applications/Resolver Evaluation

## 4.1 Jumpers 3 to 6 - Number of Zero Pulses

The number of zero pulses per motor revolution is factory set according to the required RPM and the built-in EPROM.

**Standard setting: 1 zero pulse per motor revolution**

|                        | jumper position                  |                                 |                                 |
|------------------------|----------------------------------|---------------------------------|---------------------------------|
| logic card 26.39.046.1 |                                  |                                 |                                 |
| logic card 26.39.060.2 |                                  |                                 |                                 |
| <i>RPM group</i>       | zero pulses per motor revolution |                                 |                                 |
| <i>up to 4000 RPM</i>  | 1 zero pulse per revolution      | 1 zero pulse per 1/2 revolution | 1 zero pulse per 1/4 revolution |
| <i>up to 8000 RPM</i>  | 1 zero pulse per 2 revolutions   | 1 zero pulse per revolution     | 1 zero pulse per 1/2 revolution |
| <i>up to 16000 RPM</i> | 1 zero pulse per 4 revolutions   | 1 zero pulse per 2 revolutions  | 1 zero pulse per revolutions    |



## 4.2 Jumpers 7 to 20 - Number of Angle Pulses

At the angle pulse outputs the incremental pulses required for the positioning cycles are provided.

Below the possible plug-in combinations are shown.

**Standard setting:**

- 1,024 pulses/motor revolution up to 4,000 RPM 5 V TTL level
- 512 pulses/motor revolution up to 8,000 RPM 5 V TTL level
- 256 pulses/motor revolution up to 16,000 RPM 5 V TTL level

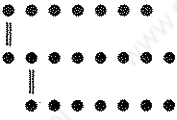
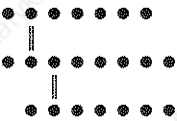
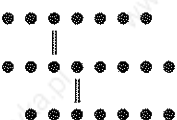
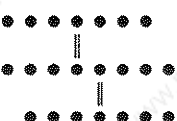
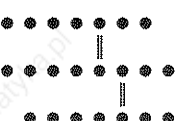
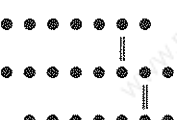
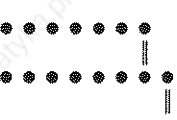
| jumper  | RPM groups        |                 |                  |
|---|-------------------|-----------------|------------------|
|   | up to 4,000 RPM   | up to 8,000 RPM | up to 16,000 RPM |
| J7<br><br>J14    | 1,024 pulses/rev. | 512 pulses/rev. | 256 pulses/rev.  |
| J8<br><br>J15   | 512 pulses/rev.   | 256 pulses/rev. | 128 pulses/rev.  |
| J9<br><br>J16  | 256 pulses/rev.   | 128 pulses/rev. | 64 pulses/rev.   |
| J10<br><br>J17 | 128 pulses/rev.   | 64 pulses/rev.  | 32 pulses/rev.   |
| J11<br><br>J18 | 64 pulses/rev.    | 32 pulses/rev.  | 16 pulses/rev.   |
| J12<br><br>J19 | 32 pulses/rev.    | 16 pulses/rev.  | 8 pulses/rev.    |
| J13<br><br>J20 | 16 pulses/rev.    | 8 pulses/rev.   | 4 pulses/rev.    |

The output of the angle pulses can be made in two ways:

- ▶ 5 V TTL level or
- ▶ as open collector with 30 V level.

Adaptation is made by means of the output IC's (see pages 3 and 5).



### 4.3 Jumpers 21 and 22 - RPM

#### → only logic card 26.39.046.1

Jumper 21 plugged in:

max. motor RPM at max. RPM ref. value presetting of  $\pm 10$  V.

Jumper 22 plugged in:

reduction by 25 % of the max. motor RPM at the same RPM ref. value presetting



#### Example

RPM ref. value presetting of  $\pm 10$  V, max. RPM 4,000 RPM.

Jumper 21 plugged in = motor rotates with 4,000 RPM

Jumper 22 plugged in = motor rotates with 3,000 RPM

**Standard setting: max. RPM**

|           | jumper position   | signification    |
|-----------|---|------------------|
| jumper 21 |  | max. RPM         |
| jumper 22 |  | 75 % of max. RPM |

### 4.4 Jumpers 23 and 24 - Angle Pulse Count Mode



Jumper 23 = Binary count mode: maximal 1024 pulses per motor revolution

Jumper 24 = Decimal count mode: Prerequisites

- counter IC's must be swapped and
- a different EPROM must be built in.

When these modifications have been made, 250 angle pulses per motor revolution are output.

**Standard setting: binary**

|           | jumper position   | angle pulse count mode |
|-----------|---|------------------------|
| jumper 23 |  | binary                 |
| jumper 24 |  | decimal                |



## 4.5 Jumpers 25 and 28 - Thermal Protection Function



Jumper 25 plugged in:

Protection function via I<sup>2</sup>t servo and PTC or thermal contact

Jumper 28 plugged in:

Protection function via I<sup>2</sup>t servo and NTC

**Standard setting: motor-dependent**

|           | jumper position   | protection function                               |
|-----------|---|---|
| jumper 25 |    | I <sup>2</sup> t servo and PTC or thermal contact |
| jumper 28 |  | I <sup>2</sup> t servo and NTC                    |

The function response can be freely defined by the user and is defined in the resistors RS 63 and RS 67.

| temperature | NTC   |       |
|-------------|-------|-------|
|             | RS 63 | RS 67 |
| ≈ 80°C      | 4 K 7 | 10 K  |
| ≈ 100°C     | 3 K 3 | 5 K 6 |
| ≈ 120°C     | 10 K  | 5 K 6 |
| ≈ 150°C     | 15 K  | 5 K 6 |

For a PTC resistor of the type YD3C515 or P426-M335 the resistance values are RS 63 = 3 K 3 and RS 67 = 1 K 5. With these values the regulator is deactivated at a temperature of 150°C.

 *Temperatures are motor winding temperatures.*



## 4.6 Jumpers 29 and 30 - Malfunction

The reaction of the drive on an error is defined with these jumpers. You can choose, whether in case of a malfunction

- ▶ the higher-ranking controller (e. g. process computer) or
- ▶ the servo module internally (as jump function)

sets the *RPM ref. value* to "zero".

**Standard wiring: internally via servo module**

| jumper position   | malfunction                             |
|---|---|
| jumper 29  | externally by higher-ranking controller |
| jumper 30  | internally by servo module              |

| Result if jumper plugged in:  |  |
|---|--|
| jumper 29*  | jumper 30**  |
| <i>RPM ref. value "zero" by higher-ranking controller</i>                               | <i>RPM ref. value "zero" by servo module</i>   |
| error occurs<br>(except OVERLOAD and overvoltage)                                       | error occurs<br>(except OVERLOAD and overvoltage)  |
| error message to the higher-ranking controller  | error message to the higher-ranking controller   internal ref. value zero input in the servo module as jump function |
| Higher-ranking controller has 1 second to bring the drive to a standstill under control | drive decelerates immediately with max. current  |
| ref. value zero input from the computer to the servo module                             | regulator is deactivated (1 second after the error has occurred)   |
| drive decelerates   |  |
| regulator is deactivated (1 second after the error has occurred)                        |  |

\* The controller can intervene within 1 second and decelerate the drive under control to the *RPM ref. value "zero"*.

\*\* Here the controller decelerates immediately and with max. current to the *RPM ref. value "zero"*, and the error message is sent to the controller.

### Instruction

**This does not apply to the error messages OVERLOAD and overvoltage. In these cases the drive is decelerated immediately.**



## 4.6.1 Evaluation of the Thermal Contact

Via the *thermal contacts* (see chapter "Wiring of Servo Modules", sections 'Pin assignments') the evaluation of the overvoltage signal from the motor is made. If the function responds, the regulator is deactivated, and the LED  $I^2t$  is on. According to the position of jumper 29 resp. 30 (see User Specific Data Sheet) the *RPM ref. value* is set to 'zero' in the servo module and with it the drive is decelerated immediately, or the higher-ranking controller has 1 sec to bring the drive to a standstill under control.

## 4.7 Jumpers 31 and 32 - Current Ref. Value Preset

Jumper 31 plugged in:

External presetting of the *Current ref. value*. The range covers  $0\text{ V} \cong 0\text{ A}$  to  $10\text{ V} \cong \text{max. admissible output current}$ .

Jumper 32 plugged in:

The max. admissible output current is always provided for the motor.

**Standard setting: internal *current ref. value* input**

|           | jumper position | current ref. value input |
|-----------|-----------------|--------------------------|
| jumper 31 |                 | external                 |
| jumper 32 |                 | internal                 |

## 4.8 Jumpers 33 and 34 - Tacho Filter Characteristics

**Standard setting: jumper 33 plugged in**

|           | jumper position        |                        | filter characteristics |
|-----------|------------------------|------------------------|------------------------|
|           | logic card 26.39.046.1 | logic card 26.39.060.2 |                        |
| jumper 33 |                        |                        |                        |
| jumper 34 |                        |                        |                        |

The tacho filter has low pass characteristics, which can be affected with jumpers 33 and 34. For more detailed information please contact manufacturer.



### 4.9 Jumpers 35 and 36 - Activation of the Position Controller

#### → only logic card 26.39.046.1

Jumper 35 plugged in:

If the drive is on a limit switch or the EMERGENCY STOP function has been activated, a position controller is activated internally in order to hold the drive drift-free in position. The drive is at standstill with the max. admissible torque.

Jumper 36 plugged in (position controller deactivated):

If the drive is on a limit switch or the EMERGENCY STOP function has been activated, the regulator is connected to the P amplifier. The drive is at standstill with reduced torque.

**Standard setting: jumper 36 plugged in**

| jumper position |  | position controller |
|-----------------|--|---------------------|
| jumper 35       |  | activated           |
| jumper 36       |  |                     |
| jumper 35       |  | not activated       |
| jumper 36       |  |                     |



## 5 Rotary switch

With the rotary switch the current commutation is set. Each position on the rotary switch is defined.

| position of switch | phase current path |
|--------------------|--------------------|
| 0                  | trapezoidal        |
| 1                  | sinusoidal         |
| 2                  | trapezoidal        |
| 3                  | sinusoidal         |
| 4                  | trapezoidal        |
| •                  | •                  |
| •                  | •                  |
| •                  | •                  |
| F                  | sinusoidal         |



## 6 Hook Switches for Zero Pulse Shifting

→ only logic card 26.39.046.1

By means of the hook switches the zero pulse can be adjusted to  $2^{12} = 4096$  positions. The adjustment is made by hooking in the corresponding hook switches on the logic card.

For higher-ranking controllers which identify the zero pulse only in case when a defined correlation between angle pulses and zero pulse exists, the table below applies:

| angle pulses per motor revolution | angle pulses  | zero pulse   | hook switches   |
|-----------------------------------|---|--|---|
| 1024                              | $U_1 = \text{high}; U_2 = \text{high};$<br>$\overline{U}_1 = \text{high}; \overline{U}_2 = \text{high};$<br>$U_1 = \text{high}; \overline{U}_2 = \text{high};$<br>$\overline{U}_1 = \text{high}; \overline{U}_2 = \text{high};$ | $U_0 = \text{high}$<br>$\overline{U}_0 = \text{high}$<br>$U_0 = \text{high}$<br>$\overline{U}_0 = \text{high}$ | 1 and 2 open<br>1 and 2 closed<br>1 closed, 2 open<br>1 open, 2 closed<br>3 to 12 variable                      |
| 512                               | $U_1 = \text{high}; U_2 = \text{high};$<br>$\overline{U}_1 = \text{high}; \overline{U}_2 = \text{high};$<br>$U_1 = \text{high}; \overline{U}_2 = \text{high};$<br>$\overline{U}_1 = \text{high}; \overline{U}_2 = \text{high};$ | $U_0 = \text{high}$<br>$\overline{U}_0 = \text{high}$<br>$U_0 = \text{high}$<br>$\overline{U}_0 = \text{high}$ | 2 and 3 open<br>2 and 3 closed<br>2 closed, 3 open<br>2 open, 3 closed<br>1 always open, 4 to 12 variable       |
| 256                               | $U_1 = \text{high}; U_2 = \text{high};$<br>$\overline{U}_1 = \text{high}; \overline{U}_2 = \text{high};$<br>$U_1 = \text{high}; \overline{U}_2 = \text{high};$<br>$\overline{U}_1 = \text{high}; \overline{U}_2 = \text{high};$ | $U_0 = \text{high}$<br>$\overline{U}_0 = \text{high}$<br>$U_0 = \text{high}$<br>$\overline{U}_0 = \text{high}$ | 3 and 4 open<br>3 and 4 closed<br>3 closed, 4 open<br>3 open, 4 closed<br>1 and 2 always open, 5 to 12 variable |
| etc.                              | etc.  | etc.   | etc.  |



## 7 Front Panel Potentiometers

### 7.1 SPEED ADJUST

Trimmer for precision adjustment of the actual RPM. The actual RPM is adjusted user-specific in factory and should only be modified in exceptional cases.

### 7.2 SPEED OFFSET

Trimmer for the drift compensation of the RPM regulator. A correct offset adjustment ensures an almost drift-free standstill of the machine axis.

For adjusting reset the ref. value of the controller to ZERO and compensate a possible drifting with the potentiometer *SPEED OFFSET* at the front panel.

#### **INSTRUCTION**

Without an active position control loop it is in general not possible to prevent drift of the motor entirely.

