

# SERIE 808

## **SERIE AX 808**

### **AC Servo Drives**

Data Sheets Issue 1/2005

Sheet 1 Table of Contents  
Sheet 2 Safety Notes 1-3  
Sheet 5 Main Komponenten  
Sheet 6 Controlsignals /1  
Sheet 7 Controlsignals /2  
Sheet 8 ENABLE Signals  
Sheet 9 Status-Signals  
Sheet 10 Fault Messages /1  
Sheet 11 Fault Messages /2

Sheet 12 Speedregulatorprint   
Sheet 13 Layout RP   
Sheet 14 Subassemblies Layout  
Sheet 15 Amplifier Dimensions /1  
Sheet 16 Amplifier Dimensions /2  
Sheet 17 AC- Motor Cable  
Sheet 18 Encoder Cable  
Sheet 19 AC- Feedback Cable  
Sheet 20 Mains Transformer Data

**HELDT & ROSSI**  
SERVO - ELECTRONIC

### General Notes

Automation engineering can only be performed safe and technically successful by qualified personnel with appropriate experience in the field of measuring and control technology. For safe installation, setup, normal operation and maintenance it is required to observe and reliably enact the warnings and safety notes contained in the equipment documentation and attached to the equipment.

Only professional personnel or if necessary, trained persons as defined in DIN 31000/VDE 0100 (Section 3.6 "User") are capable of interpreting correctly the safety notes and warnings issued generally in the documentation and attached to devices, and act appropriately in a concrete individual situation.

For obvious reasons documentation cannot neither take into account every detail of all variation of the described devices nor every conceivable case of project work, operation or maintenance.

H&R will answer to all safety-related and application-specific questions, and will take notice of your suggestions for the improvement of devices and the documentation.

Documentation is not any part of a "facts of the case". The obligations of H&R are exclusively a result of the general business and delivery terms of the HELDT & ROSSI Servoelektronik GmbH.

### Qualified Personnel

Qualified personnel is synonymous with

- persons that are familiar with project work and with the safety concepts of electrical engineering and automation technology
- persons that are trained for the work with and in the operation of automation technology, and who understand the documentation contents related to the operation
- persons assigned with commissioning and servicing, who have the according education/experience, and are thus qualified to set power circuits and devices/systems into operation, to ground and to mark them according to the safety standards.

### Risk information

The thorough consideration of the key terms described further down is inalienable for the physical safety of application and maintenance personnel, and to prevent damage to the described product and/or to devices attached to it.



#### **Danger**

means that physical or fatal injury will be inflicted or damage to property may occur if corresponding precautions are not taken.



#### **Warning**

means that death, physical injury or damage to property can occur if corresponding precautions are not taken.

#### **>Caution<**

means that physical injury or damage to property can occur if corresponding precautions are not taken.

#### **-Attention-**

means that attention is drawn to safety relevant facts according to the definition of "Note" or "Caution".

#### **Note**

is an essential, selective help information for the product or the corresponding part of a documentation.

### Intended Purpose Use

Every H&R device/system must only be used for the intended purpose that it was designed for and that is specified in the technical documentation. Connections to external devices and components must be coordinated with H&R during the project phase for safety reasons and to maintain the warranty. H&R products are designed, manufactured, tested and documented according to the relevant safety standards. When the regulations and safety-related notes issued for the intended use and maintenance are observed the products will not present under normal conditions a hazard to health or of damage to property. Further requirements for perfect and safe operation of a device are: Appropriate transport, storage, installation and assembly as well as careful operation and maintenance.

### Installation and Initial Operation

Every automation device is part of a larger system or installation. The following notes serve to support the safe integration of a device into its environment.

#### **Warning**

By removing the housing respectively protective cover, or by opening the system cabinet parts of these devices /systems could be touched that may conduct dangerous voltages. Only qualified personnel are eligible to manually access these devices /systems.

This personnel must be experienced in all hazards and maintenance procedures in accordance with the relevant device documentation.

In addition it is expected to have a field-oriented problem and safety awareness.

#### **Note**

Even if by design a maximum of functional safety is obtained it is imperative to follow the instructions contained in the documentation because wrong measures can defeat the purpose of arrangements for preventing dangerous faults, or can even create additional hazards.

#### **Warning**

The current safety and accident prevention regulations must be observed in the respective application case. Devices designed for installation in a housing or electrical cabinet must only be operated when they are installed. Devices with perforated housing (Ventilation) must be installed after all wiring work has been finished, otherwise it must be protected adequately against intrusion by foreign objects.

Installations with local connection (stationary devices/systems) that are not equipped with a safe power disconnect switch and/or fuse must be fitted with a safe power disconnect switch or fuse; the installation must be grounded. A freely accessible grounded power outlet must be located in close vicinity to devices/systems that have a fixed, non-detachable connection line and are without a safe power disconnect switch.

Before starting line power supplied devices they must be checked if their voltage range setting matches with the local line voltage.

Line voltage fluctuation must stay within the specified tolerance limits of the connected device. Failure to observe this may result in faulty operation and dangerous conditions of the electrical modules.

Procedures must be arranged for a controlled restart of a program that is interrupted by a voltage brownout or blackout. Such an event must not lead to a hazardous condition at any time. If necessary an Emergency-Stop must be triggered.

Emergency-Stop facilities according to EN 60204-1/IEC 204-1 (VDE 0113) must remain serviceable under all operating modes of the automation installation. The reset of an Emergency-Stop facility must not lead to uncontrolled restart. 24 V power supplies must have safe electrically isolation.

### >Attention<

The installation of connecting and signal lines must be as to prevent as much as possible inductive and capacitive interference and must not cause disturbance of automation functions or reduction of the control characteristics. Instructions given by H&R for the type of cable to be used for certain production areas are constituent part of the specification for the device/system. Operating elements and sensors must be installed as to sufficiently prevent unintentional operation.

Appropriate hardware and software measures must be planned that will prevent undefined conditions in the automation system in case of interrupted signal leads on I/O interfaces.

### Active and Passive Faults of an Automation System

Both, active and passive faults can be hazardous in electronic automation systems: in a drive control it is generally the active fault that is dangerous because it leads to an unauthorized motion of the machine. A passive fault could prevent a signal function from issuing a warning message about a hazardous operating condition. Categorizing possible faults into hazardous and non-hazardous types is of utmost importance for any risk assessment.

### Warning

Additional arrangements e.g. independent limit switches, mechanical stop bolts, safe retardation areas etc. must be added, or facilities must be created that will respectively force a safe operation of automation systems that will inflict injury or cause great damage to property if dangerous faults occur.

### Service and Maintenance Procedures

Required measurements or tests on an active device must only be made at the test points clearly marked by H&R. The measuring instruments must be of state of the art technology regarding electric isolation, burden on the test point and general handling safety. A suitable electric tool must be used.

### Warning

Unauthorized accessing and inexperienced repairs may lead to serious or fatal injury as well as considerable damage to property. Repair to a H&R automation system must only be performed through service providers that are authorized by H&R. Only spare parts must be used that meet all specifications of the parts list issued by H&R for that device. A blown power fuse is a reaction only to a defect in the H&R device, but not to an overload. Replacing the fuse without prior rectification of the fault leads to considerable consequential damage and forfeits all warranty claims.

- Before opening the device always disconnect power by unplugging the power connector or by switching off the disconnecting switch.
- Fuses must be replaced with the same type as specified in the technical data of the device.
- Do not dispose of batteries in fire and do not solder to the cell housing, explosion hazard! (maximum temperature is 100 °C). Batteries containing Lithium or Mercury must not be opened and must not be recharged, use same type replacement only!
- Batteries or accumulators must be disposed of like special waste.

**H&R documentation is reviewed periodically to keep it updated. It can be modified at any time without prior notice. All H&R literature contains information protected by copyright. Reproduction of any type or translation into other languages without prior written approval of H&R is prohibited.**

# SERIE 808

## AC SERVOSYSTEMS

Main Components, Data

Z.Nr.: T 808 AE 005 Vers.:

Servomotor Type	P <sub>N</sub> Watt	n <sub>N</sub> RPM	M <sub>N</sub> Nm	Servoamplifier		I <sub>A eff</sub> stat / dyn	Transformer Standard
				Type			
MX 808 L 412	150	2000	0,7	AX 808	250 - 150	1,2 / 3,5	HT 331
MX 808 L 413	220	3000	0,7	AX 808	500 - 150	2,2 / 6,5	HT 331
MX 808 L 422	280	2000	1,3	AX 808	500 - 150	2,2 / 6,5	HT 331
MX 808 L 423	410	3000	1,3	AX 808	750 - 150	3,7 / 10,5	HT 331
MX 808 L 512	220	2000	1,1	AX 808	500 - 150	2,2 / 6,5	HT 331
MX 808 L 513	270	3000	0,9	AX 808	500 - 150	2,2 / 6,5	HT 331
MX 808 L 522	360	2000	1,8	AX 808	750 - 150	3,7 / 10,5	HT 331
MX 808 L 523	450	3000	1,5	AX 808	1250 - 150	5,9 / 17,5	HT 351
MX 808 L 532	480	2000	2,4	AX 808	1250 - 150	5,9 / 17,5	HT 351
MX 808 L 533	630	3000	2,1	AX 808	1250 - 150	5,9 / 17,5	HT 351
MX 808 L 612	440	2000	2,1	AX 808	750 - 150	3,7 / 10,5	HT 331
MX 808 L 613	660	3000	2,1	AX 808	750 - 150 / 1250 - 150		
MX 808 L 622	790	2000	3,8	AX 808	1250 - 150	5,9 / 17,5	HT 351
MX 808 L 623	1070	3000	3,4	AX 808	1750 - 150	9,1 / 27,5	HT 440
MX 808 L 632	1150	2000	5,5	AX 808	1750 - 150	9,1 / 27,5	HT 440
MX 808 L 633	1500	3000	4,8	AX 808	2500 - 150	12,6 / 38,5	HT 464
MX 808 L 812	1100	2000	5,1	AX 808	1750 - 150	9,1 / 27,5	HT 440
MX 808 L 813	1500	3000	4,9	AX 808	2500 - 150	12,6 / 38,5	HT 464
MX 808 L 822	2030	2000	9,7	AX 808	2500 - 150	12,6 / 38,5	HT 464
MX 808 L 823	2980	3000	9,5	AX 808	3500 - 150	17,0 / 42,0	HT 560
MX 808 L 832	2570	2000	12,3	AX 808	2500 - 150 / 3500 - 150		
MX 808 L 833	3770	3000	12,0	AX 808	3500 - 210	17,0 / 42,0	HT 560
MX 808 L 842	3450	2000	16,5	AX 808	3500 - 210	17,0 / 42,0	HT 560
MX 808 L 843	4550	3000	14,5	AX 808	5000 - 210	21,0 / 42,0	HT 652
MX 808 L 1032	3770	2000	18,0	AX 808	3500 - 210	17,0 / 42,0	HT 560
MX 808 L 1033	4650	3000	15,0	AX 808	5000 - 210	21,0 / 42,0	HT 652
MX 808 L 1042	4500	2000	22,5	AX 808	5000 - 210	21,0 / 42,0	HT 652

All motors available with integrated DC-Holding-Break and Incremental Encoder .  
Besides the above named Standard-Motors the following custom-built versions are available:

Type LA... with compressed air-cooling  
Type LW... with water -, oil cooling  
Type L...X... A-side Special-Design  
(flange, bearings, shaft-end)

Multi-Axis Installations may be supplied by a common Transformer. The H&R- Multi-Axis Transformers have floating Secondary Windings to prevent any Interference.

If Axes must be activated individually : Switch Sec.-Voltage for each Amplifier. In this case inrush-current limitation is necessary (capacitive Load).  
Ask H&R for support.

**HELDT & ROSSI**  
SERVO . ELECTRONIC

<b>XC1</b>	/1	O	4V/1000Umin-1	<b>Speed-Monitor</b>
	/2	O	-2V/+10V	<b>Motortemp.-Monitor</b> Range -20°C to +100°C =-2,0V to +10,0V
	/3	O		Shield Input-Cable
	/4	I	±10V	<b>SW+ Diff. Input</b>
	/5	I		<b>SW-</b> Values depend on Customers P.C.B.
	/6	I/O		Values depend on
	/7	I/O		Customers P.C.B.
	/8	O		
	/9	O		
	/10	I	H=24V L=0V, open RE=30k	<b>SV Zero Speed Command</b> Low = controlled Standstill independent of Input Signal
<b>XC2</b>	/1	I	H=24V L=0V, open RE=30k	<b>RN Lock negative</b> Low=ccw Motor-Rotation locked
	/2	I	H=24V L=0V, open RE=30k	<b>RP Lock positive</b> Low=cw Motor-Rotation locked
	/3	I	H=24V L=0V, open RE=30k	<b>EF Endposition Release</b> To return from an Endposition After Return: set Low
	/4	I	H=24V L=0V, open RE=30k	<b>RS General Lock</b> Low=Ampli. locked, Motor idling
	/5	O	±10V = Mmax	<b>Torque-Monitor</b>
	/6	I	0 to +10V RE>2k	<b>Current-Programm Input</b> Dyn. Current
	/7	I	0 to +3,3V RE>2k	<b>Current-Programm Input</b> Stat. Current
	/8	O		
	/9	O	+15V; IA max=100mA	<b>Auxiliary Voltage</b>
	/10	O	-15V; IA max=100mA	<b>Auxiliary Voltage</b>

**XC3** / 1      Ground  
 / 2  r1  
 / 3 

/ 4  r3  
 / 5  r2  
 / 6 

/ 7  r4  
 / 8 

/ 9    I      +24V

/10    O

**XC4 Earth**

**XC5/** 1IH= +15-24V  
 RE= 15k

/ 2.../10

**XC6** / 1.../10

**XB** / 1    O  
 / 2    O      +24V; IA max=1,5A

**XG**

**XM** / 1    O      Output-Values  
 / 2    O      depend on Device  
 / 3    O

**XS** / 1    I      Input-Values  
 / 2    I      depend on Device  
 / 3    I

**Relay r1** reports:  
 stat. Current Limit reached or overtemp. warning  
 Select with Br 3.  
 Standard: Current Limit

**Relay r3** reports:  
 Speed <0,5% of nominal speed (Contact opens)

**Relay r2** reports:  
 Speed-Reg. Fault > ca.3%. (Contact opens)

**Relay r4** reports:**Ready**  
 (Contact opens in case of malfunction)  
 Contact capacity r1, r2, r3, r4:  
 I<sub>max</sub>=1A, U<sub>max</sub>=110V, P<sub>max</sub>=30VA  
 Livetime at 24V, 0.1A load: 3 x10<sup>7</sup> operations  
 Input ext. +24V Supply for DC-Brake  
 and DISABLE storage.

**Ground** ext. +24V supply

**Electronic Ground**  
 For satisfactory operation connect according  
 H&R Wiring-Specification

**DC-Brake** Command  
 High = Brake open

see "Control Signals AX808"

**H&R Feedback System** Connector

**DC-Brake**, Ground  
**DC-Brake**, activated over XC5/1.  
 Shortproof. Brake Action shown by LED below XB1/2.  
 Brake Control remains intact after Ampli. turnoff  
 by means of the ext. fed +24V DC (XC3/9-10)

**Earth Connection of Case and Motorcable Shield**

**AC-Servomotor**  
 Phase-Position to be observed!

**Sec. Winding** (from Mains-Transformer)  
 Phase Position any

ENABLE-Signals have an effect on Powerstage and Speedregulator located on Customers Print RP... Signal status ( XC 1/ 10 und XC 2/ 1-4: SV, EF, RN, RP, RS ) is shown by green LED´s on the front of the amplifier.

### 1.1 Result in Power Stage:

			a	b	c	d
XC2 / 1	Lock negative	RN	X	H	L	H
XC2 / 2	Lock positive	RP	X	H	H	L
XC2 / 3	General Lock	RS	L	H	H	H

- a Powerstage locked (Motor currentless)
- b Working Condition**, both directions of rotation possible
- c Negative rotation locked, pos. rotation possible when pos. limit switch is activated
- d Positive rotation locked, neg. rotation possible when neg. limit switch is activated

### 1.2 Result in Speedregulator Print:

(The ENABLE-Signals controls two FET-Switches on RP.: S1:Set Value Path, S2:Speedreg. PI/P-Switch)

			a	b	c	d	e	f
XC1 /10	Zero speed command	SV	X	X	H	L	X	X
XC2 / 1	Lock negative	RN	X	X	H	H	X	L
XC2 / 2	Lock positive	RP	X	X	H	H	L	X
XC2 / 3	Endposition release	EF	X	H	L	L	L	L
XC2 / 4	General lock	RS	L	H	H	H	H	H

- a Powerstage, Set value path locked (S1 open), Speedregulator in P- Condition (S2 closed)
- b Set value path activated (S1 closed), Speedregulator in PI- Condition (S2 open)
- c Working condition:** Set value path activated, Speedregulator in PI- Condition (S2 open)
- d Set value path locked (S1 open), Speedregulator in PI- Condition (S2 open): regulated Stand Still
- e / f as point a

### Standard-Configuration of ENABLE-Signals:

- XC2 / 1 Travel Limit Switch for negative movement
- XC2 / 2 Travel Limit Switch for positive movement
- XC1 /10 Standstill command
- XC2 / 3 Endposition release (combined with manual release)
- XC2 / 4 General lock

### Standard-Startup-Routine:

RS, SV, EF are low.  
Switch on Supply of Amplifier, Set value should be set to zero.  
SV set high: Set value path activated. RS set high: Amplifier is activated

### Endposition release:

If the direction dependent Locks (correctly allocated to the travel limit switches) are activated when driving into an endposition: the motor brakes automatically to standstill with max. torque .  
When limit switches are incorrectli allocated: the motor is idling.

### Moving out of an Endposition:

Set Value set to zero. EF set high.  
Move out of Endposition with Set Value of correct polarity (wrong polarity is ignored).  
When limit switch signalizes "free", set EF low.



Condition-/Status-Signals should be inserted into the supervisory equipment of the machine/plant. With these signals the driveproblems can be detected much faster than it is possible with the CNC above.

Example: the Signal "Speedregulator fault" detects regulation-problems earlier then the CNC-message "Lag error".

#### Working Condition Messages:

Static currentlimit reached	(Istat)	Istat, Idyn and Temperature warning (D7)
Dynamic currentlimit reached	(Idyn)	shown by yellow LEDs
Motor Standstill	(Speed < 0.5% nNom.)	
Speedregulator fault	Deviation > ca. 3%	
High Powerstage-Temperature	>70° C (Temp.warn.)	

#### "Currentlimit reached ":

Typical reasons for this message:

- At initial startup of a machine:  
The stipulated acceleration/deceleration times are too short,  
Machine runs rough.  
No torque buildup possible, i.e. motor not, or wrong, connected,  
Fault within the currentregulator circuit of the device.
- In Produktion:  
Working forces too high, driving in mechanical endposition,  
Deterioration of mechanical maschine data  
Acceleration/deceleration-times too short  
Break in motor-circuit

#### " Motor Standstill ":

Typical evaluation possibilities:

Security-locks on machine parts and tools

Variation of certain Parameters at low speed: i.e. dynamic parameters, torque limitation.

#### " Speedregulator fault":

Typical evaluation-possibilities:

Realtime-signal at growing Lag-error, uncontrolled movements , drive into current-limitation.

#### " High Powerstage Temperature":

This signal gives a powerstage-temperature prewarning (leading to shutdown of the device when the limit is reached).

Typical reasons:

Bad ventilation, pollution of fans and filters, fault of heatexchanger.

Controlled termination of the working process can be established.

#### "Ready "

"Ready" signalizes a functioning device and is signalized by relaiscontacts XC 3/ 7- 8 and Signal-Output on XC 5/ 9.

Indication with green LED (D0).

This Signal must be inserted into Emergency-Off cicuits.

**All important values of the device are permanently checked.**

A fault-message leads to an immediate lock of the powerstage (device currentless).

Signals appear on outputs XC5/2-7 and are visible by red LED's (D1-D6).

**Operating Mode of Disable-LED's:**

LED continuously on: Fault present.

LED blinking: Shorttime-Fault, Fault no longer present.

(At normal operation, see chapter 5: Storage of DISABLE-Messages.)

**Supervision:**

**Trigger:**

**LED:**

Mains undervoltage	- 20 % referred to UNominal	D2
Mains Overvoltage	+20 % referred to UNominal	D1+D2
Earthconnection	Fault current > 1A	D4
Feedback-System	Malfunction and cable interruption	D3
Brake energy	too high for built in ballastresistor.	D1
Internal Supply	+/- 10%	D5
Powerstage Temperature	>80 °C	D4+D6
Motor Temperature	>100 °C	D6

**RESET-Options:**

There are three options of reactivating a DISABLE-locked device.

The Reset-Mode is defined by Jumpers on the Controlboard in front of the device.

Jumpers must be set only in currentless condition.

**Mode 1:** Jumper set in position J5 (Factory default):

Device becomes reactivated by Shutdown and following switch on .

**Mode 2:** Jumper set in position J4 :

Reset like Mode 1, but also by an external Reset-Impuls on XC 5/ 10.

Complicated Startup-procedures may be avoided with "external Reset".

**Mode 3:** Jumper set in position J3: (Auto-Reset)

Device is locked only when a fault is present and returns to normal operation after fault ends.

Auto-Reset is suitable under circumstances where shorttime-faults may be tolerated:

Belt conveyors, Spindle drives...

**Important Note:**

In all H&R-Devices (wire) fuses are used only as emergency-fuses.

They blow only under severe device-malfunction, not under "Overload".

Fuses must be replaced after repair by the same type only.

**Careless fuse replacement deletes warranty and may cause heavy damages.**

Working condition- and Fault-Messages (see chapter 2-4) appear coded at XC 5/ 2-9.

Fault-Messages have higher priority than Condition-messages, this means that they appear at XC 5 only under undisturbed circumstances.

### Decoding of Working Condition-Messages:

	XC5/ 2	3	4	5	6	7	8	9
Static current limit reached	X	L	L	X	X	X	X	H
Dynamic current limit reached	X	X	L	L	X	X	X	H
Motor Standstill	L	X	X	X	L	X	X	H
Speedregulator fault	X	X	X	X	L	L	X	H
High Powerstage Temperature	X	X	X	X	X	X	L	H

### Decoding of Fault Messages::

Modus: 1, 2      3

	XC5/ 2	3	4	5	6	7	9	9
Mains undervoltage	H	L	H	H	H	H	L	X
Mains Overvoltage	L	L	H	H	H	H	L	X
Earth connection	H	H	H	L	H	H	L	X
Feedback-System	H	H	L	H	H	H	L	X
Brake energy	L	H	H	H	H	H	L	X
Internal Supply	H	H	H	H	L	H	L	X
Powerstage Temperature	H	H	H	L	H	L	L	X
Motor Temperature	H	H	H	H	H	L	L	X

After switching on the device and regular function High signals appear on all XC 5 outputs.

This initial condition should always be checked before releasing General Lock.

Hint: After switch off "Mains Undervoltage" appears.

### Storage of DISABLE Messages:

When applying 24V DC on XC3/ 9,10 the DISABLE-Messages may be monitored after device shutdown. The actual Messages and indicators remain stored until switching on again or Reset on XC5/10.

Scanning the outputs after shorttime-faults requires some special routine, as the outputs of a locked device are static outputs.

### Scanning-Routine:

#### Reset Mode 1:

Reset-Impuls on XC5/10. If it is possible to delete the fault-message, it was a shorttime-fault.

Otherwise the fault or a further fault is present.

#### Reset Mode 2:

Reset-Impuls on XC5/10. After successful acknowledgement of the faultmessage(s) the device works normally a working condition messages can be read out.

Hint: Because the device is working immediately after successful acknowledgement, General Lock should be activated before Reset to prevent uncontrolled movement of the drive.

#### Reset Mode 3:

When Low on XC5/9 this means static fault. Acknowledgement is useless (Autoreset would have done it). All signals must be decoded to discriminate between fault signals and condition signals.

By result "fault" and "high" on XC5/9: Shorttime-fault.

The last fault is always indicated.

# SERIE 808

## Speed-Regul.print RP100-8

Layout / Parts List

Z.Nr.: Lvzyk / e 30 Vers.: B

**Attention! Plug / unplug currentless only**

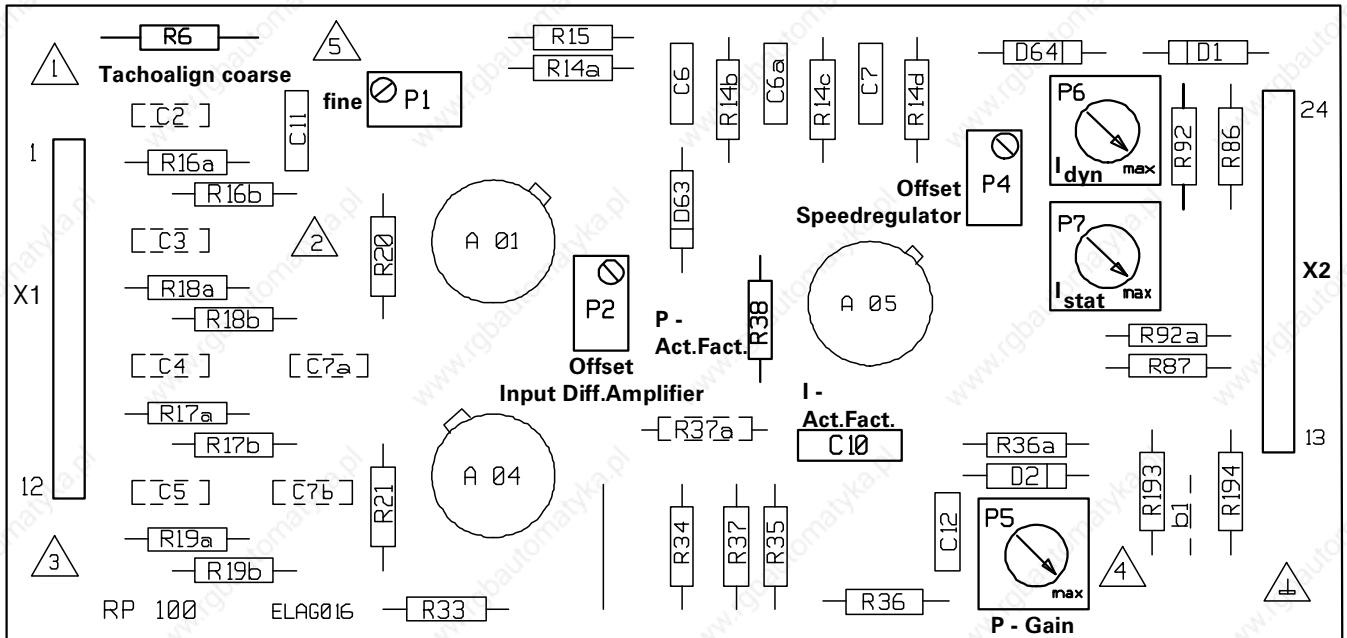

A 01	$\mu$ A 741 sel.	R 6	Bridge	R 92	2K21
A 04	DG 200 BA	R 14a	10k	R 92a	68R1
A 05	$\mu$ A 741 sel	R 14b	10k	R 193	953R
D 1	1N4148	R 14c	10k	R 194	1k1
D 2	1N4148	R 14d	9k09		
D 63	1N4148	R 15	18k2		
D 64	1N4148	R 16a	4k99		
C 2	no	R 16b	4k99		
C 3	no	R 17a	4k99		
C 4	no	R 17b	4k99		
C 5	no	R 18a	4k99		
C 6	33 nF	R 18b	4k99		
C 6a	33 nF	R 19a	4k99		
C 7	no	R 20	10k		
C 7a	no	R 21	10k		
C 7b	no	R 33	2k21		
C 10	100nF	R 34	39k2		
C 11	47nF	R 35	27k4		
C 12	47nF	R 36	100R		
P 1	10k	R 36a	100R		
P 2	10k	R 37	1k		
P 4	10k	R 37a	no		
P 5	10k	R 38	82k5		
P 6	1k	R 86	681R		
P 7	1k	R 87	332R		

### Notes

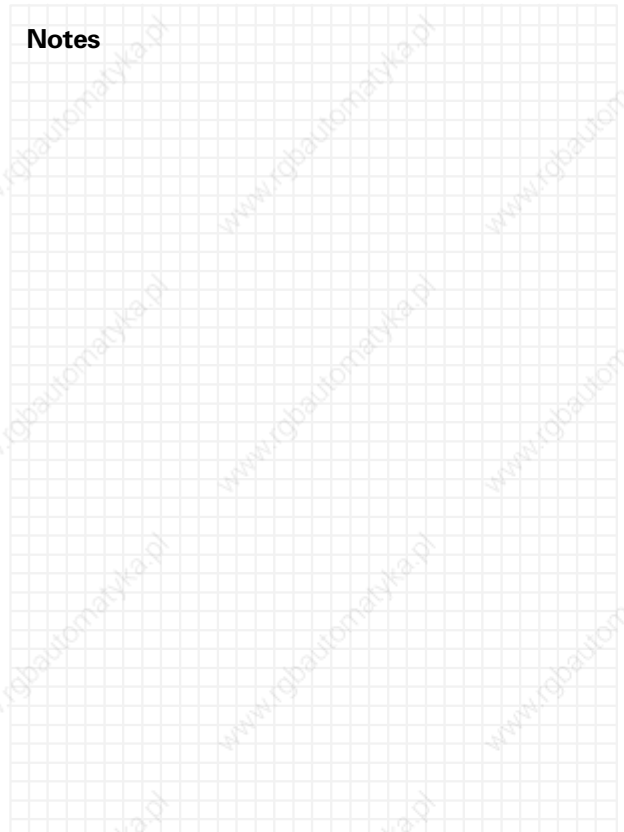

**HELDT & ROSSI**  
SERVO - ELECTRONIC



# SERIE 808

## Layout Sub - Assemblies

Z.Nr.: L 808 A/DE 02 Vers.:

9  
8  
7  
6  
5  
4  
3  
2  
1  
0

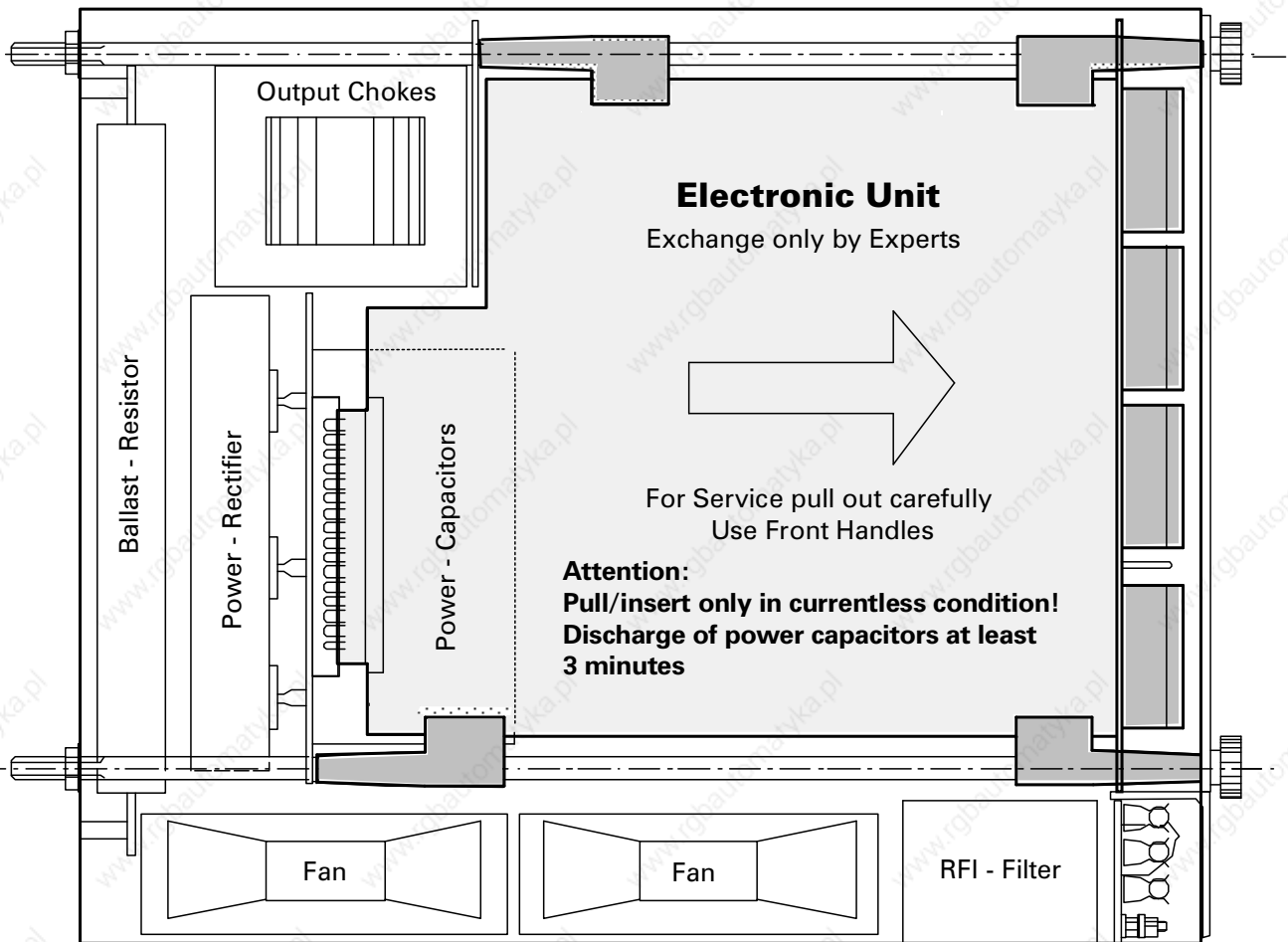

A B C D

**HELDT & ROSSI**  
SERVO - ELECTRONIC

# SERIE 808

## Mech. Dimensions AX 808

Size 1 ( 250 - 3500 W )

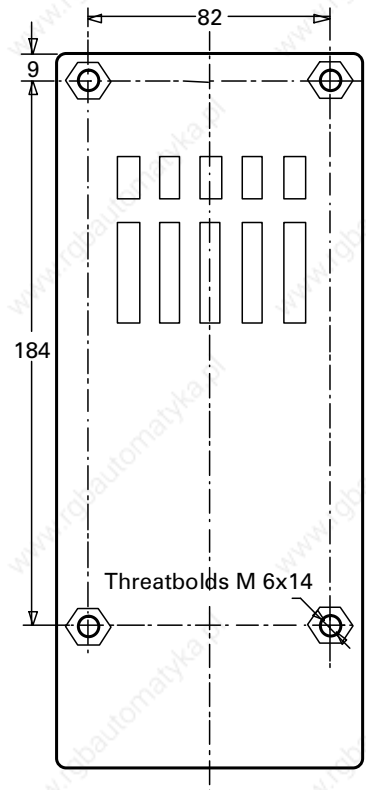
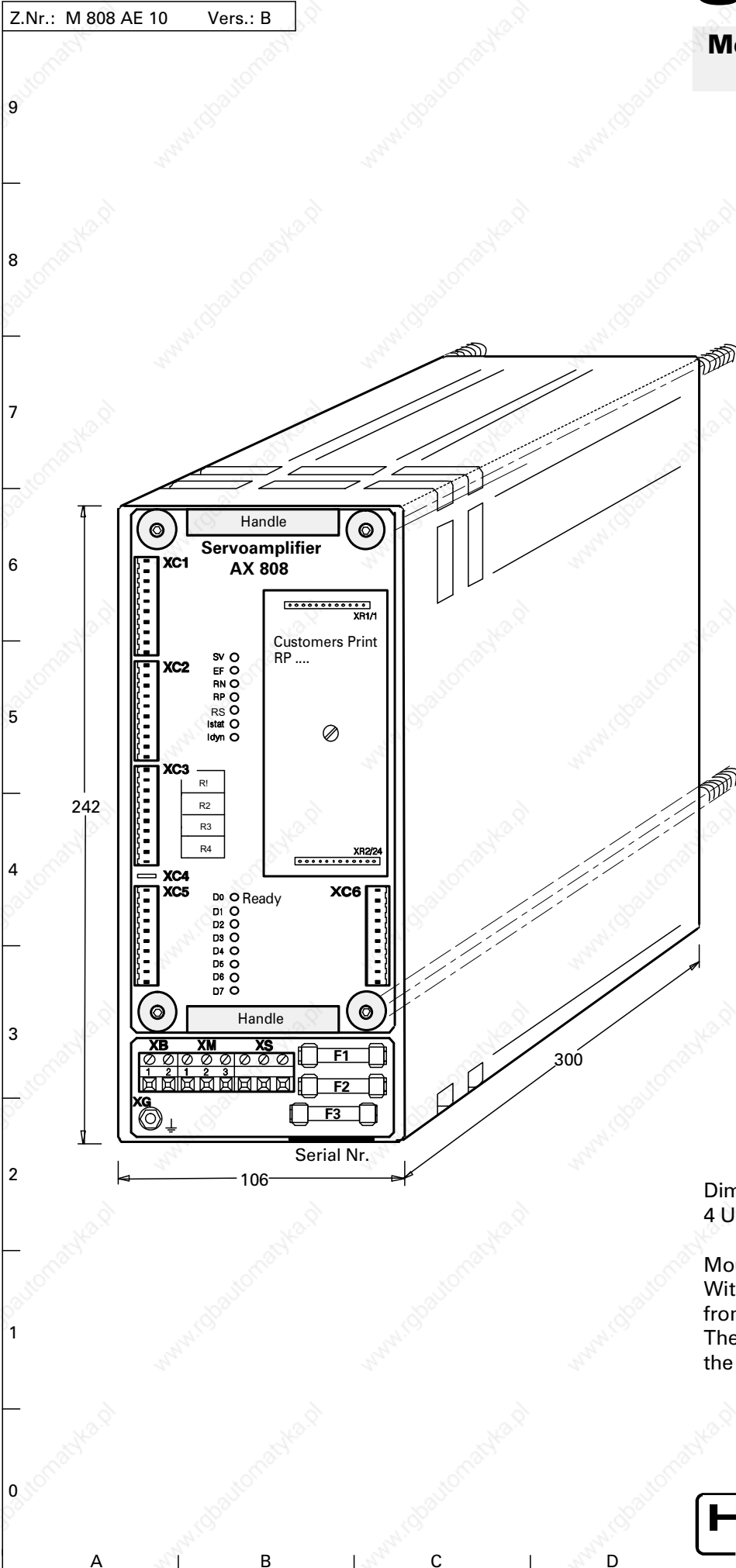

Dimensions suitable for 19" Systems.  
4 Units can be mounted in 19" with.

Mounting of device:  
With rotatable mounting bolts and  
frontside hexagonal holes.  
Thereby the unit can be fastened to  
the carrier from the front.

**HELDT & ROSSI**  
SERVO - ELECTRONIC

# SERIE 808

## Mech. Dimensions AX 808

Size 2 ( 5000W and Custom )

Z.Nr.: M 808 AE 11    Vers.: B

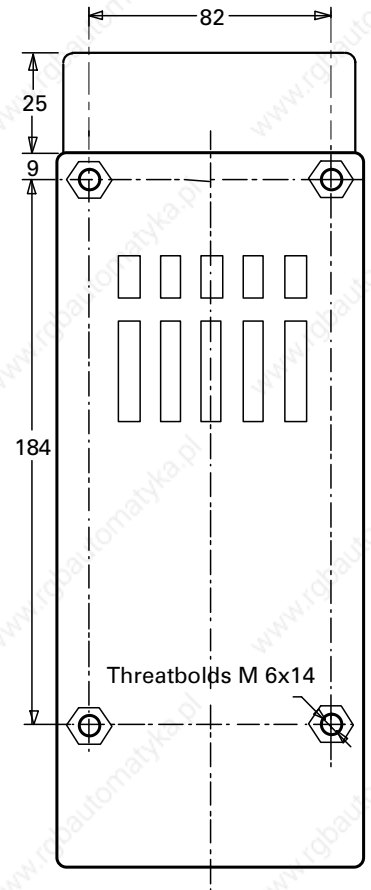
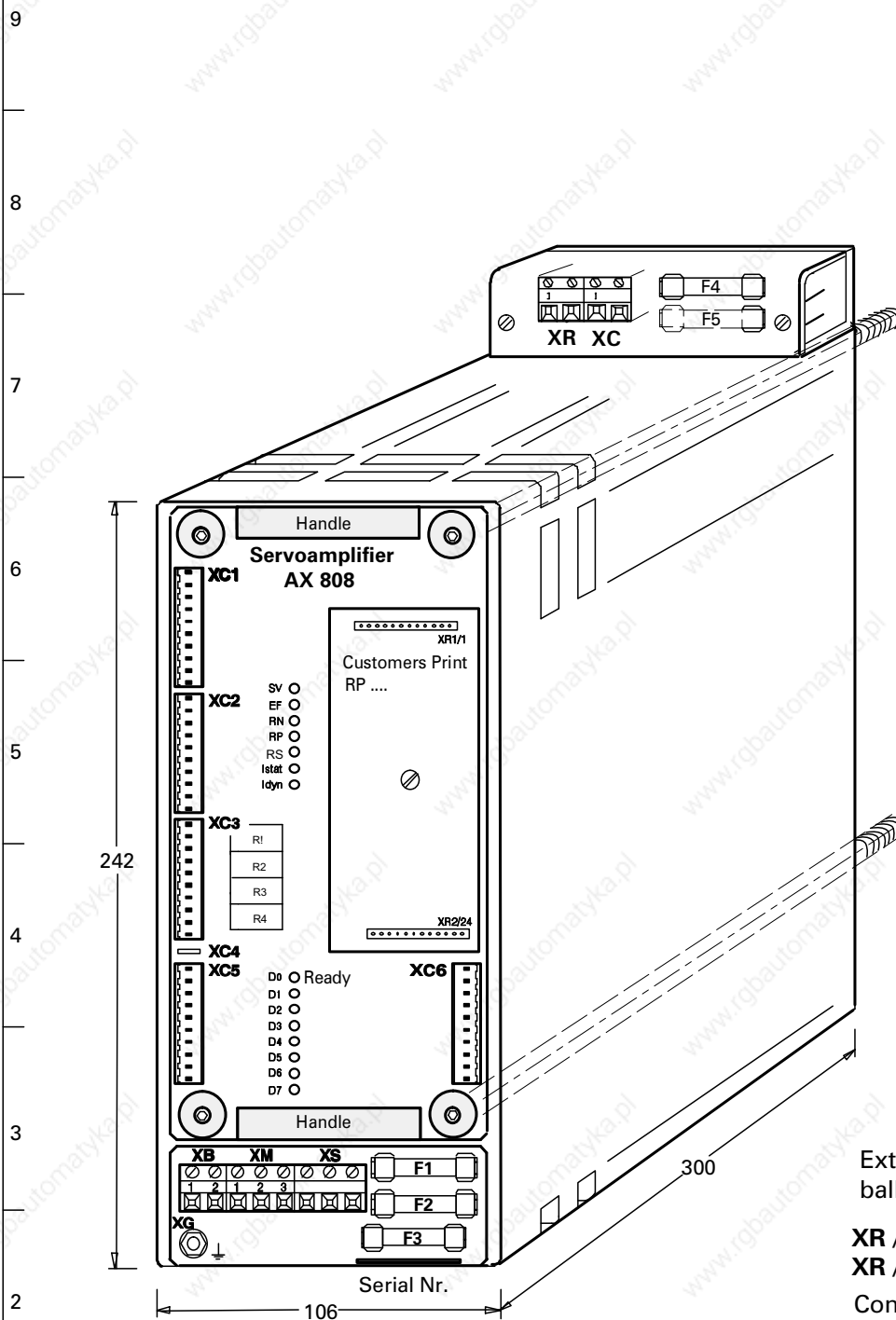

Dimensions suitable for 19" Systems.  
4 Units can be mounted in 19" with.

Mounting of device:  
With rotatable mounting bolts and  
frontside hexagonal holes.  
Thereby the unit can be fastened to  
the carrier from the front.

External access to power capacitors  
ballast resistor:

**XR / 1**  
**XR / 2** Ballast Resistor

Connection of additional ballast-  
resistors at high braking energy

**XC / 1** Power Capacitor minus  
**XC / 2** Power Capacitor plus

Connection of additional power-  
capacitors or H&R energy storage  
(Shorttime mains interruption bridge)

**HELDT & ROSSI**  
SERVO . ELECTRONIC





# SERIE 808

## Motor Connectors

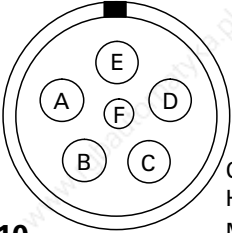
Series MX 808 L . . .

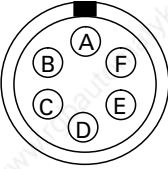
Motor	Motor side	Signal	H&R - Cabel Multishield Type A	Amplifier side
 <p><b>Type L8..,L10..</b></p>	<b>XMO</b> / A	MPh 1	wire Nr. 1	<b>XM / 1</b>
	/ B	MPh 2	wire Nr. 2	<b>XM / 2</b>
	/ C	MPh 3	wire Nr. 3	<b>XM / 3</b>
	/ D	Shield / earth jel/grn		<b>XG</b>
	/ E	Brake	+ red	<b>XB / 2</b>
	/ F	Brake	- blue	<b>XB / 1</b>

 <p><b>Type L5..,L6...</b></p>	<b>XMO</b> / A	MPh 1	wire Nr. 1	<b>XM / 1</b>
	/ B	MPh 2	wire Nr. 2	<b>XM / 2</b>
	/ C	MPh 3	wire Nr. 3	<b>XM / 3</b>
	/ D	Shield / earth jel/grn		<b>XG</b>
	/ E	Brake	+ red	<b>XB / 2</b>
	/ F	Brake	- blue	<b>XB / 1</b>

 <p><b>Type L4....</b></p>	<b>XMO</b> / 1,2,3	MPh 1	wire Nr. 1	<b>XM / 1</b>
	/ 4,5,6,	MPh 2	wire Nr. 2	<b>XM / 2</b>
	/ 7,8,9,	MPh 3	wire Nr. 3	<b>XM / 3</b>
	/ 10	Shield / earth jel/grn		<b>XG</b>
	/ 11	Brake	+ red	<b>XB / 2</b>
	/ 12	Brake	- blue	<b>XB / 1</b>

### H&R - AC - Feedbacksystem

 <p>Cabel Connector H&amp;R Nr.:EEKS 812 Motor Flange Recept. H&amp;R Nr.:EEKS 802</p>	<b>XTP</b> / 1	TPh 1+	bwn	<b>XC / 10</b>
	/ 2	TPh 1 -	wht	/ 9
	/ 3	TPh 2+	grn	/ 8
	/ 4	TPh 2	jel	/ 7
	/ 5	TPh 3+	gry	/ 6
	/ 6	TPh 3	pnk	/ 5
	/ 7	Masse TF	blu	/ 4
	/ 8	TF	red	/ 3
	/ 9	Masse MT	blk	/ 2
	/ 10	MT	vio	/ 1
	/ 11	Inner shields	see drawing	
	/ 12	Outer shield	S808 T 002	

### Integrated Incremental Encoder (up to 5000 l / Rev.)

 <p>Cabel Connector H&amp;R Nr.:EEKS 811 Motor Flange Recept. H&amp;R Nr.:EEKS 801</p>	<b>XID</b> / 1	$\overline{Ua2}$	jel	-----
	/ 2	+5V Sensor	grn	-----
	/ 3	Ua0	gry	-----
	/ 4	$\overline{Ua0}$	pnk	-----
	/ 5	Ua1	blu	-----
	/ 6	$\overline{Ua1}$	red	-----
	/ 7	n.c.	inner shields	<b>Masse</b> -----
	/ 8	Ua2	bwn	-----
	/ 9 / Housing		outer shield	<b>Earth</b> -----
	/ 10	0V (UN)	wht	-----
	/ 11	0V Sensor	blk	-----
	/ 12	+5V (UP)	vio	-----

## Encoder Cabel

Wiring motor side

The use of the HELDT & ROSSI Multishield Cable is necessary to guarantee the high precision and dynamic of the HELDT & ROSSI AC Drives even under complicated installation conditions.

This cable can be obtained as piece goods or customized.

Technical Data HELDT & ROSSI - MULTISHIELD Encoder Cabel:











Stranded wire acc. to VDE 0259 KI.5  
 PVC-outer jacket RAL 7001  
 oil/gas persistent acc. to VDE 0250/0472  
 Shield density appr. 85%

Diameter 11,5 mm

Color Code H&R  
 after july '94 DIN 47100

Temperature range:  
 mobile  
 -5 bis +80°C  
 fixed  
 -20 bis +80°C

### H&R Color code

XID /	1	$\overline{Ua 2}$	wht	
	2	+5V sens	grn	
	3	Ua 0	jell	
	4	$\overline{Ua 0}$	wht	
	5	Ua 1	gry	
	6	$\overline{Ua 1}$	wht	
	7	n.c.	inner shields	
	8	Ua 2	bwn	
	9 /Housing		outer shield	
	10	0V (UN)	wht	
	11	0V sens	wht	
	12	+5V (UP)	pnk	

Above cable will be replaced  
 by cable with Color code  
 acc. DIN 47100:

XID /	1	$\overline{Ua 2}$	jel
	2	+5V sens	grn
	3	Ua 0	gry
	4	$\overline{Ua 0}$	pnk
	5	Ua 1	blu
	6	$\overline{Ua 1}$	red
	7	n.c.	inner shields
	8	Ua 2	bwn
	9 /Housing		outer shields
	10	0V (UN)	wht
	11	0V sens	blk
	12	+5V (UP)	vio

CONINVERS-Connector  
 Typ RC-12S2N121C16  
 H&R Art.Nr. EEKS 811

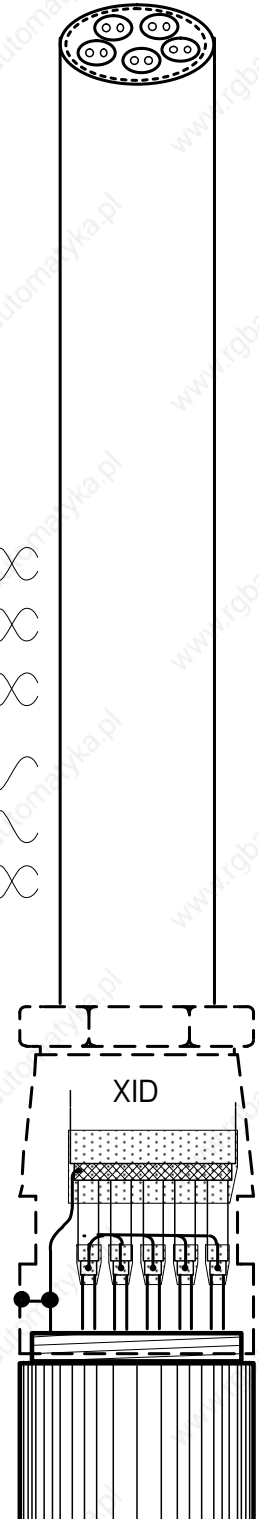

## AC Feedback cabel

Wiring

The use of the HELDT & ROSSI Multishield Cable is necessary to guarantee the high precision and dynamic of the HELDT & ROSSI AC Drives even under complicated installation conditions.

This cable can be obtained as piece goods or customized.

Technical Data of HELDT & ROSSI - MULTISHIELD - Motorcabel :

Stranded wire acc. to VDE 0259 KI.5  
 PVC-outer jacket RAL 7001  
 oil/gas persistent acc. to VDE 0250/0472  
 Shield density appr. 85%

Diameter 12mm  
 Color code DIN 47100

Temperature range:

mobile  
 -5 bis +80°C  
 fixed  
 -20 bis +80°C

C: 11.93

### Amplifier side

- XC6** / 10 brown  
 9 white  
 8 green  
 7 yellow  
 6 gray  
 5 pink  
 4 blue  
 3 red  
 2 black  
 1 violet

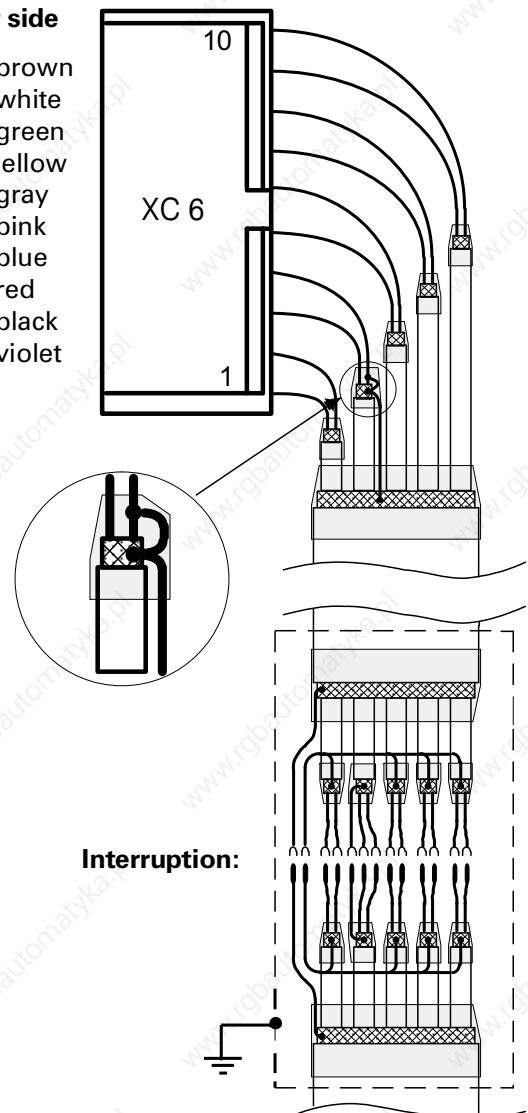

### Motor side

- XTP** / 1 brown  
 2 white  
 3 green  
 4 yellow  
 5 gray  
 6 pink  
 7 blue  
 8 red  
 9 black  
 10 violet  
 11 inner shields  
 12 outer shield

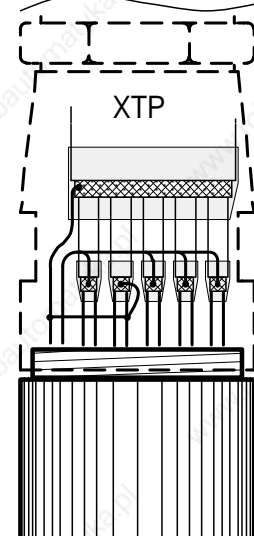

# SERIE 808

## Standard Transformers

SERIE 808

Z.Nr.: M 808 TE 01

Vers.:

H&R Mains Transformers (acc. VDE 0550 / 0551)

H&R Transformers are provided to supply  
H&R Servoamplifiers exclusively.

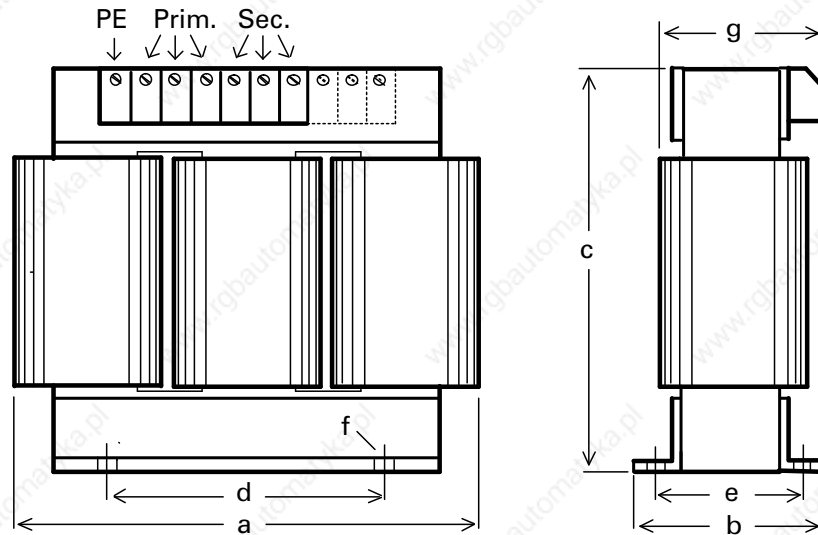

Dimensions in mm, a,b,e +/- 2mm

TYP	Primary-Fuses (at 380/400 V)	VA	a	b	c	d	e	f	g	kg	Amplifier Type
HT 331	3x 2 A slow	600	180	70	155	120	53	8	82	6,5	250 / 750
HT 351	3x 4 A slow	1000	180	90	155	120	73	8	102	10,0	1250
HT 440	3x 5 A slow	1500	225	85	195	152	62	11	93	13,5	1750
HT 464	3x 7 A slow	2000	225	110	195	152	87	11	118	18,5	2500
HT 560	3x 10 A slow	3000	260	115	230	176	89	11	120	26,0	3500
HT 652	3x 15 A slow	4000	300	110	260	200	82	11	115	32,0	5000
HT 763	3x 18 A slow	6000	360	145	310	240	103	11	130	51,0	7500
HT 778	3x 20 A slow	8000	360	160	310	240	118	11	145	63,0	multiple
HT 793	3x 25 A slow	10000	360	175	310	240	132	11	160	76,0	multiple

To supply several amplifiers:  
Multiaxes-Transformers are available.

**HELDT & ROSSI**  
SERVO - ELECTRONIC