

## Am27C010

### 1 Megabit (128 K x 8-Bit) CMOS EPROM

#### DISTINCTIVE CHARACTERISTICS

- **Fast access time**
  - Speed options as fast as 45 ns
- **Low power consumption**
  - 20  $\mu$ A typical CMOS standby current
- **JEDEC-approved pinout**
- **Single +5 V power supply**
- **$\pm 10\%$  power supply tolerance standard**
- **100% Flashrite™ programming**
  - Typical programming time of 16 seconds
- **Latch-up protected to 100 mA from  $-1$  V to  $V_{CC} + 1$  V**
- **High noise immunity**
- **Versatile features for simple interfacing**
  - Both CMOS and TTL input/output compatibility
  - Two line control functions
- **Standard 32-pin DIP, PDIP, and PLCC packages**

#### GENERAL DESCRIPTION

The Am27C010 is a 1 Megabit, ultraviolet erasable programmable read-only memory. It is organized as 128K words by 8 bits per word, operates from a single +5 V supply, has a static standby mode, and features fast single address location programming. Products are available in windowed ceramic DIP packages, as well as plastic one time programmable (OTP) PDIP and PLCC packages.

Data can be typically accessed in less than 45 ns, allowing high-performance microprocessors to operate without any WAIT states. The device offers separate Output Enable (OE#) and Chip Enable (CE#) controls,

thus eliminating bus contention in a multiple bus micro-processor system.

AMD's CMOS process technology provides high speed, low power, and high noise immunity. Typical power consumption is only 100 mW in active mode, and 100  $\mu$ W in standby mode.

All signals are TTL levels, including programming signals. Bit locations may be programmed singly, in blocks, or at random. The device supports AMD's Flashrite programming algorithm (100  $\mu$ s pulses), resulting in a typical programming time of 16 seconds.

#### BLOCK DIAGRAM

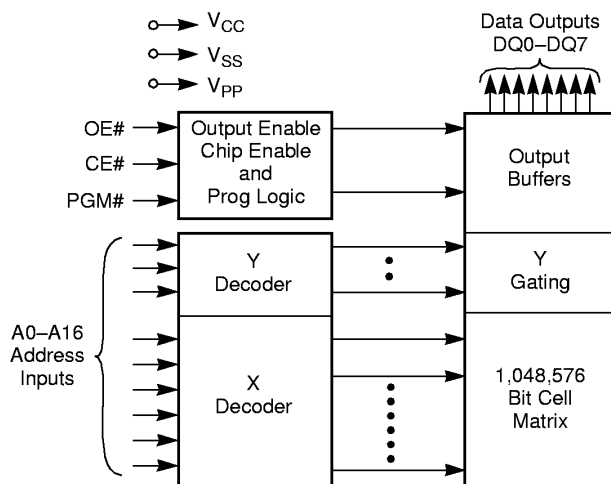

**\* For complete Rochester ordering guide, please refer to page 2 \***

Rochester Electronics guarantees performance of its semiconductor products to the original OEM specifications. "Typical" values are for reference purposes only. Certain minimum or maximum ratings may be based on product characterization, design, simulation, or sample testing. Rochester Electronics reserves the right to make changes without further notice to any specification herein.

# AM27C010

## Rochester Ordering Guide

Rochester Part Number	AMD Part Number	Package	Temperature
AM27C010-45DC	AM27C010-45DC	CDIP-32	0° to +70°C
AM27C010-45DC5	AM27C010-45DC5	CDIP-32	0° to +70°C
AM27C010-45DC5B	AM27C010-45DC5B	CDIP-32	0° to +70°C
AM27C010-45DCB	AM27C010-45DCB	CDIP-32	0° to +70°C
AM27C010-45DI	AM27C010-45DI	CDIP-32	-40° to +85°C
AM27C010-45DI5	AM27C010-45DI5	CDIP-32	-40° to +85°C
AM27C010-45DI5B	AM27C010-45DI5B	CDIP-32	-40° to +85°C
AM27C010-45DIB	AM27C010-45DIB	CDIP-32	-40° to +85°C
AM27C010-45EC	AM27C010-45EC	TSSOP-32, Plastic	0° to +70°C
AM27C010-45EC5	AM27C010-45EC5	TSSOP-32, Plastic	0° to +70°C
AM27C010-45EI	AM27C010-45EI	TSSOP-32, Plastic	-40° to +85°C
AM27C010-45EI5	AM27C010-45EI5	TSSOP-32, Plastic	-40° to +85°C
AM27C010-45JC	AM27C010-45JC	LDCC-32, Plastic	0° to +70°C
AM27C010-45JC5	AM27C010-45JC5	LDCC-32, Plastic	0° to +70°C
AM27C010-45JI	AM27C010-45JI	LDCC-32, Plastic	-40° to +85°C
AM27C010-45JI5	AM27C010-45JI5	LDCC-32, Plastic	-40° to +85°C
AM27C010-45PC	AM27C010-45PC	PDIP-32	0° to +70°C
AM27C010-45PC5	AM27C010-45PC5	PDIP-32	0° to +70°C
AM27C010-45PI	AM27C010-45PI	PDIP-32	-40° to +85°C
AM27C010-45PI5	AM27C010-45PI5	PDIP-32	-40° to +85°C
AM27C010-55DC	AM27C010-55DC	CDIP-32	0° to +70°C
AM27C010-55DCB	AM27C010-55DCB	CDIP-32	0° to +70°C
AM27C010-55DI	AM27C010-55DI	CDIP-32	-40° to +85°C
AM27C010-55DIB	AM27C010-55DIB	CDIP-32	-40° to +85°C
AM27C010-55EC	AM27C010-55EC	TSSOP-32, Plastic	0° to +70°C
AM27C010-55EI	AM27C010-55EI	TSSOP-32, Plastic	-40° to +85°C
AM27C010-55JC	AM27C010-55JC	LDCC-32, Plastic	0° to +70°C
AM27C010-55JI	AM27C010-55JI	LDCC-32, Plastic	-40° to +85°C
AM27C010-55PC	AM27C010-55PC	PDIP-32	0° to +70°C
AM27C010-55PI	AM27C010-55PI	PDIP-32	-40° to +85°C
AM27C010-70DC	AM27C010-70DC	CDIP-32	0° to +70°C
AM27C010-70DCB	AM27C010-70DCB	CDIP-32	0° to +70°C
AM27C010-70DI	AM27C010-70DI	CDIP-32	-40° to +85°C
AM27C010-70DIB	AM27C010-70DIB	CDIP-32	-40° to +85°C
AM27C010-70EC	AM27C010-70EC	TSSOP-32, Plastic	0° to +70°C
AM27C010-70EI	AM27C010-70EI	TSSOP-32, Plastic	-40° to +85°C
AM27C010-70JC	AM27C010-70JC	LDCC-32, Plastic	0° to +70°C
AM27C010-70JI	AM27C010-70JI	LDCC-32, Plastic	-40° to +85°C
AM27C010-70LC	AM27C010-70LC	LLCC-32, Ceramic	0° to +70°C
AM27C010-70LCB	AM27C010-70LCB	LLCC-32, Ceramic	0° to +70°C
AM27C010-70LI	AM27C010-70LI	LLCC-32, Ceramic	-40° to +85°C
AM27C010-70LIB	AM27C010-70LIB	LLCC-32, Ceramic	-40° to +85°C
AM27C010-70PC	AM27C010-70PC	PDIP-32	0° to +70°C
AM27C010-70PI	AM27C010-70PI	PDIP-32	-40° to +85°C
AM27C010-90DC	AM27C010-90DC	CDIP-32	0° to +70°C

# AM27C010

## Rochester Ordering Guide (continued)

Rochester Part Number	AMD Part Number	Package	Temperature
AM27C010-90DCB	AM27C010-90DCB	CDIP-32	0° to +70°C
AM27C010-90DI	AM27C010-90DI	CDIP-32	-40° to +85°C
AM27C010-90DIB	AM27C010-90DIB	CDIP-32	-40° to +85°C
AM27C010-90EC	AM27C010-90EC	TSSOP-32, Plastic	0° to +70°C
AM27C010-90EI	AM27C010-90EI	TSSOP-32, Plastic	-40° to +85°C
AM27C010-90JC	AM27C010-90JC	LDCC-32, Plastic	0° to +70°C
AM27C010-90JI	AM27C010-90JI	LDCC-32, Plastic	-40° to +85°C
AM27C010-90LC	AM27C010-90LC	LLCC-32, Ceramic	0° to +70°C
AM27C010-90LCB	AM27C010-90LCB	LLCC-32, Ceramic	0° to +70°C
AM27C010-90LI	AM27C010-90LI	LLCC-32, Ceramic	-40° to +85°C
AM27C010-90LIB	AM27C010-90LIB	LLCC-32, Ceramic	-40° to +85°C
AM27C010-90PC	AM27C010-90PC	PDIP-32	0° to +70°C
AM27C010-90PI	AM27C010-90PI	PDIP-32	-40° to +85°C
AM27C010-120DC	AM27C010-120DC	CDIP-32	0° to +70°C
AM27C010-120DCB	AM27C010-120DCB	CDIP-32	0° to +70°C
AM27C010-120DI	AM27C010-120DI	CDIP-32	-40° to +85°C
AM27C010-120DIB	AM27C010-120DIB	CDIP-32	-40° to +85°C
AM27C010-120DE	AM27C010-120DE	CDIP-32	-55° to +125°C
AM27C010-120DEB	AM27C010-120DEB	CDIP-32	-55° to +125°C
AM27C010-120EC	AM27C010-120EC	TSSOP-32, Plastic	0° to +70°C
AM27C010-120EI	AM27C010-120EI	TSSOP-32, Plastic	-40° to +85°C
AM27C010-120JC	AM27C010-120JC	LDCC-32, Plastic	0° to +70°C
AM27C010-120JI	AM27C010-120JI	LDCC-32, Plastic	-40° to +85°C
AM27C010-120LC	AM27C010-120LC	LLCC-32, Ceramic	0° to +70°C
AM27C010-120LCB	AM27C010-120LCB	LLCC-32, Ceramic	0° to +70°C
AM27C010-120LE	AM27C010-120LE	LLCC-32, Ceramic	-55° to +125°C
AM27C010-120LEB	AM27C010-120LEB	LLCC-32, Ceramic	-55° to +125°C
AM27C010-120LI	AM27C010-120LI	LLCC-32, Ceramic	-40° to +85°C
AM27C010-120LIB	AM27C010-120LIB	LLCC-32, Ceramic	-40° to +85°C
AM27C010-120PC	AM27C010-120PC	PDIP-32	0° to +70°C
AM27C010-120PI	AM27C010-120PI	PDIP-32	-40° to +85°C
AM27C010-150DC	AM27C010-150DC	CDIP-32	0° to +70°C
AM27C010-150DCB	AM27C010-150DCB	CDIP-32	0° to +70°C
AM27C010-150DI	AM27C010-150DI	CDIP-32	-40° to +85°C
AM27C010-150DIB	AM27C010-150DIB	CDIP-32	-40° to +85°C
AM27C010-150DE	AM27C010-150DE	CDIP-32	-55° to +125°C
AM27C010-150DEB	AM27C010-150DEB	CDIP-32	-55° to +125°C
AM27C010-150EC	AM27C010-150EC	TSSOP-32, Plastic	0° to +70°C
AM27C010-150EI	AM27C010-150EI	TSSOP-32, Plastic	-40° to +85°C
AM27C010-150JC	AM27C010-150JC	LDCC-32, Plastic	0° to +70°C
AM27C010-150JI	AM27C010-150JI	LDCC-32, Plastic	-40° to +85°C
AM27C010-150LC	AM27C010-150LC	LLCC-32, Ceramic	0° to +70°C
AM27C010-150LCB	AM27C010-150LCB	LLCC-32, Ceramic	0° to +70°C
AM27C010-150LE	AM27C010-150LE	LLCC-32, Ceramic	-55° to +125°C
AM27C010-150LEB	AM27C010-150LEB	LLCC-32, Ceramic	-55° to +125°C

# AM27C010

## Rochester Ordering Guide (continued)

Rochester Part Number	AMD Part Number	Package	Temperature
AM27C010-150LI	AM27C010-150LI	LLCC-32, Ceramic	-40° to +85°C
AM27C010-150LIB	AM27C010-150LIB	LLCC-32, Ceramic	-40° to +85°C
AM27C010-150PC	AM27C010-150PC	PDIP-32	0° to +70°C
AM27C010-150PI	AM27C010-150PI	PDIP-32	-40° to +85°C
AM27C010-200DC	AM27C010-200DC	CDIP-32	0° to +70°C
AM27C010-200DCB	AM27C010-200DCB	CDIP-32	0° to +70°C
AM27C010-200DI	AM27C010-200DI	CDIP-32	-40° to +85°C
AM27C010-200DIB	AM27C010-200DIB	CDIP-32	-40° to +85°C
AM27C010-200DE	AM27C010-200DE	CDIP-32	-55° to +125°C
AM27C010-200DEB	AM27C010-200DEB	CDIP-32	-55° to +125°C
AM27C010-200EC	AM27C010-200EC	TSSOP-32, Plastic	0° to +70°C
AM27C010-200EI	AM27C010-200EI	TSSOP-32, Plastic	-40° to +85°C
AM27C010-200JC	AM27C010-200JC	LDCC-32, Plastic	0° to +70°C
AM27C010-200JI	AM27C010-200JI	LDCC-32, Plastic	-40° to +85°C
AM27C010-200LC	AM27C010-200LC	LLCC-32, Ceramic	0° to +70°C
AM27C010-200LCB	AM27C010-200LCB	LLCC-32, Ceramic	0° to +70°C
AM27C010-200LE	AM27C010-200LE	LLCC-32, Ceramic	-55° to +125°C
AM27C010-200LEB	AM27C010-200LEB	LLCC-32, Ceramic	-55° to +125°C
AM27C010-200LI	AM27C010-200LI	LLCC-32, Ceramic	-40° to +85°C
AM27C010-200LIB	AM27C010-200LIB	LLCC-32, Ceramic	-40° to +85°C
AM27C010-200PC	AM27C010-200PC	PDIP-32	0° to +70°C
AM27C010-200PI	AM27C010-200PI	PDIP-32	-40° to +85°C
AM27C010-255DC	AM27C010-255DC	CDIP-32	0° to +70°C
AM27C010-255DCB	AM27C010-255DCB	CDIP-32	0° to +70°C
AM27C010-255DI	AM27C010-255DI	CDIP-32	-40° to +85°C
AM27C010-255DIB	AM27C010-255DIB	CDIP-32	-40° to +85°C
AM27C010-255DE	AM27C010-255DE	CDIP-32	-55° to +125°C
AM27C010-255DEB	AM27C010-255DEB	CDIP-32	-55° to +125°C
AM27C010-255EC	AM27C010-255EC	TSSOP-32, Plastic	0° to +70°C
AM27C010-255EI	AM27C010-255EI	TSSOP-32, Plastic	-40° to +85°C
AM27C010-255JC	AM27C010-255JC	LDCC-32, Plastic	0° to +70°C
AM27C010-255JI	AM27C010-255JI	LDCC-32, Plastic	-40° to +85°C
AM27C010-255LC	AM27C010-255LC	LLCC-32, Ceramic	0° to +70°C
AM27C010-255LCB	AM27C010-255LCB	LLCC-32, Ceramic	0° to +70°C
AM27C010-255LE	AM27C010-255LE	LLCC-32, Ceramic	-55° to +125°C
AM27C010-255LEB	AM27C010-255LEB	LLCC-32, Ceramic	-55° to +125°C
AM27C010-255LI	AM27C010-255LI	LLCC-32, Ceramic	-40° to +85°C
AM27C010-255LIB	AM27C010-255LIB	LLCC-32, Ceramic	-40° to +85°C
AM27C010-255PC	AM27C010-255PC	PDIP-32	0° to +70°C
AM27C010-255PI	AM27C010-255PI	PDIP-32	-40° to +85°C

# AM27C010

## PRODUCT SELECTOR GUIDE

Family Part Number		Am27C010							
Speed Options	V <sub>CC</sub> = 5.0 V ± 5%	-45							-255
	V <sub>CC</sub> = 5.0 V ± 10%	-45	-55	-70	-90	-120	-150	-200	
Max Access Time (ns)		45	55	70	90	120	150	200	250
CE# (E#) Access (ns)		45	55	70	90	120	150	200	250
OE# (G#) Access (ns)		25	35	35	40	50	65	75	75

## CONNECTION DIAGRAMS

### Top View

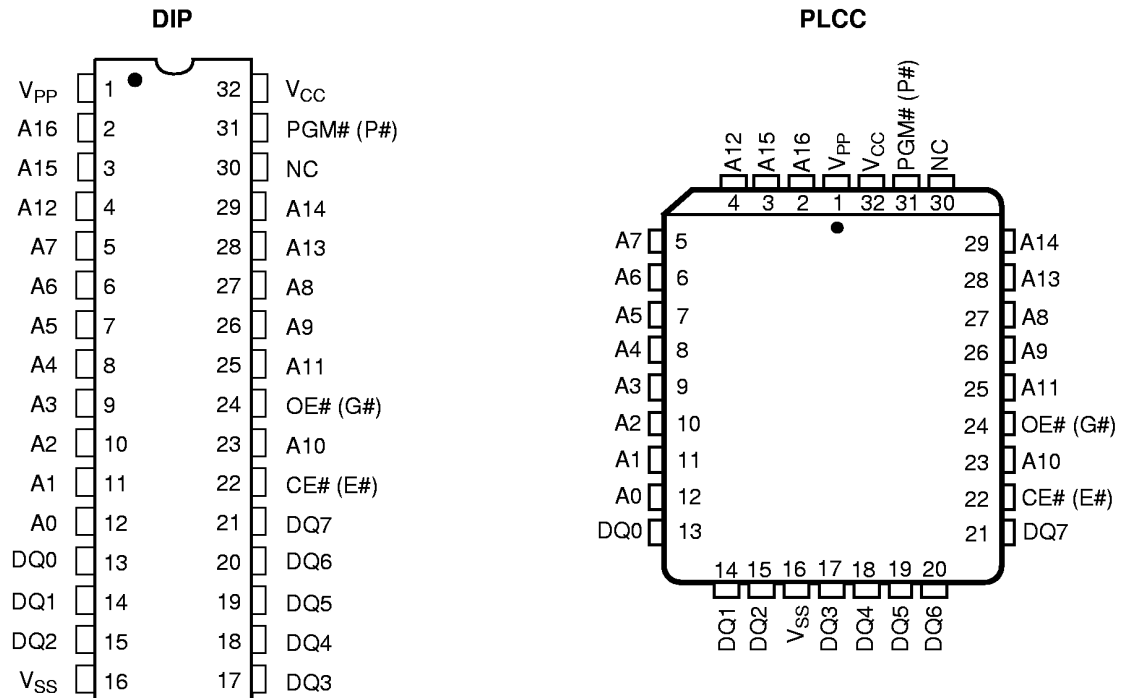

### Notes:

1. JEDEC nomenclature is in parenthesis.
2. The 32-pin DIP to 32-pin PLCC configuration varies from the JEDEC 28-pin DIP to 32-pin PLCC configuration.

## PIN DESIGNATIONS

A0–A16	=	Address Inputs
CE# (E#)	=	Chip Enable Input
DQ0–DQ7	=	Data Input/Outputs
OE# (G#)	=	Output Enable Input
PGM# (P#)	=	Program Enable Input
V <sub>CC</sub>	=	V <sub>CC</sub> Supply Voltage
V <sub>PP</sub>	=	Program Voltage Input
V <sub>SS</sub>	=	Ground

## LOGIC SYMBOL

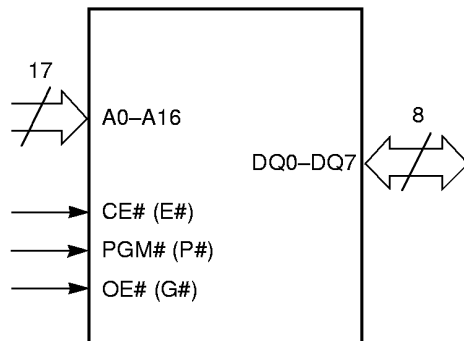

## ABSOLUTE MAXIMUM RATINGS

Storage Temperature	
OTP Products . . . . .	-65°C to +125°C
All Other Products . . . . .	-65°C to +150°C
Ambient Temperature with Power Applied . . . . .	-55°C to +125°C
Voltage with Respect to $V_{SS}$	
All pins except A9, $V_{PP}$ , $V_{CC}$ . . . . .	-0.6 V to $V_{CC} + 0.6$ V
A9 and $V_{PP}$ (Note 2) . . . . .	-0.6 V to 13.5 V
$V_{CC}$ (Note 1) . . . . .	-0.6 V to 7.0 V

### Notes:

1. Minimum DC voltage on input or I/O pins -0.5 V. During voltage transitions, the input may overshoot  $V_{SS}$  to -2.0 V for periods of up to 20 ns. Maximum DC voltage on input and I/O pins is  $V_{CC} + 5$  V. During voltage transitions, input and I/O pins may overshoot to  $V_{CC} + 2.0$  V for periods up to 20 ns.
2. Minimum DC input voltage on A9 is -0.5 V. During voltage transitions, A9 and  $V_{PP}$  may overshoot  $V_{SS}$  to -2.0 V for periods of up to 20 ns. A9 and  $V_{PP}$  must not exceed +13.5 V at any time.

Stresses above those listed under "Absolute Maximum Ratings" may cause permanent damage to the device. This is a stress rating only; functional operation of the device at these or any other conditions above those indicated in the operational sections of this specification is not implied. Exposure of the device to absolute maximum ratings for extended periods may affect device reliability.

## OPERATING RANGES

### Commercial (C) Devices

Ambient Temperature ( $T_A$ ) . . . . . 0°C to +70°C

### Industrial (I) Devices

Ambient Temperature ( $T_A$ ) . . . . . -40°C to +85°C

### Extended (E) Devices

Ambient Temperature ( $T_A$ ) . . . . . -55°C to +125°C

### Supply Read Voltages

$V_{CC}$  for  $\pm 5\%$  devices . . . . . +4.75 V to +5.25 V

$V_{CC}$  for  $\pm 10\%$  devices . . . . . +4.50 V to +5.50 V

Operating ranges define those limits between which the functionality of the device is guaranteed.

# AM27C010

## DC CHARACTERISTICS over operating range (unless otherwise specified)

Parameter Symbol	Parameter Description	Test Conditions	Min	Max	Unit
$V_{OH}$	Output HIGH Voltage	$I_{OH} = -400 \mu A$	2.4		V
$V_{OL}$	Output LOW Voltage	$I_{OL} = 2.1 \text{ mA}$		0.45	V
$V_{IH}$	Input HIGH Voltage		2.0	$V_{CC} + 0.5$	V
$V_{IL}$	Input LOW Voltage		-0.5	+0.8	V
$I_{LI}$	Input Load Current	$V_{IN} = 0 \text{ V to } V_{CC}$		1.0	
$I_{LO}$	Output Leakage Current	$V_{OUT} = 0 \text{ V to } V_{CC}$		5.0	$\mu A$
$I_{CC1}$	$V_{CC}$ Active Current (Note 2)	$CE\# = V_{IL}$ , $f = 10 \text{ MHz}$ , $I_{OUT} = 0 \text{ mA}$	C/I Devices	30	mA
			E Devices	60	
$I_{CC2}$	$V_{CC}$ TTL Standby Current	$CE\# = V_{IH}$		1.0	mA
$I_{CC3}$	$V_{CC}$ CMOS Standby Current	$CE\# = V_{CC} \pm 0.3 \text{ V}$		100	$\mu A$
$I_{PP1}$	$V_{PP}$ Supply Current (Read)	$CE\# = OE\# = V_{IL}$ , $V_{PP} = V_{CC}$		100	$\mu A$

**Caution:** The device must not be removed from (or inserted into) a socket when  $V_{CC}$  or  $V_{PP}$  is applied.

**Notes:**

- $V_{CC}$  must be applied simultaneously or before  $V_{PP}$  and removed simultaneously or after  $V_{PP}$ .
- $I_{CC1}$  is tested with  $OE\# = V_{IH}$  to simulate open outputs.
- Minimum DC Input Voltage is  $-0.5 \text{ V}$ . During transitions, the inputs may overshoot to  $-2.0 \text{ V}$  for periods less than  $20 \text{ ns}$ . Maximum DC Voltage on output pins is  $V_{CC} + 0.5 \text{ V}$ , which may overshoot to  $V_{CC} + 2.0 \text{ V}$  for periods less than  $20 \text{ ns}$ .

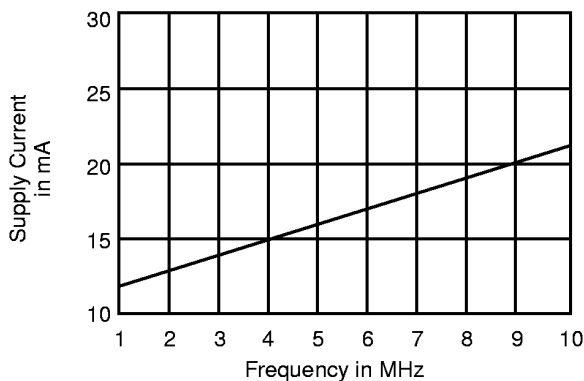

**Figure 1. Typical Supply Current vs. Frequency**  
 $V_{CC} = 5.5 \text{ V}$ ,  $T = 25^\circ\text{C}$

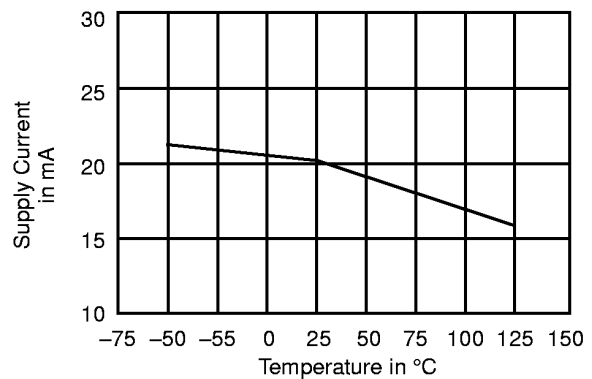

**Figure 2. Typical Supply Current vs. Temperature**  
 $V_{CC} = 5.5 \text{ V}$ ,  $f = 10 \text{ MHz}$

# AM27C010

## TEST CONDITIONS

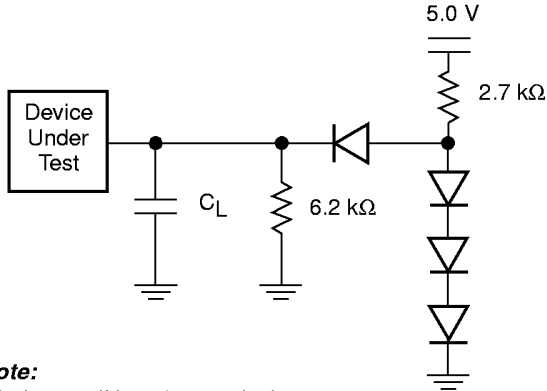

**Note:**  
Diodes are IN3064 or equivalents.

**Figure 3. Test Setup**

**Table 1. Test Specifications**

Test Condition	-45, -55	All others	Unit
Output Load	1 TTL gate		
Output Load Capacitance, $C_L$ (including jig capacitance)	30	100	pF
Input Rise and Fall Times	≤ 20		ns
Input Pulse Levels	0.0–3.0	0.45–2.4	V
Input timing measurement reference levels	1.5	0.8, 2.0	V
Output timing measurement reference levels	1.5	0.8, 2.0	V

## SWITCHING TEST WAVEFORM

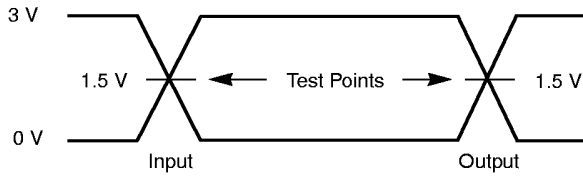

**Note:** For  $C_L = 30$  pF.

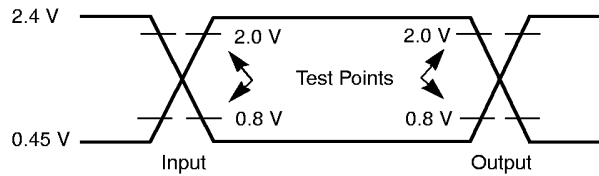

**Note:** For  $C_L = 100$  pF.

## KEY TO SWITCHING WAVEFORMS

WAVEFORM	INPUTS	OUTPUTS
		Steady
		Changing from H to L
		Changing from L to H
	Don't Care, Any Change Permitted	Changing, State Unknown
	Does Not Apply	Center Line is High Impedance State (High Z)



# AM27C010

## AC CHARACTERISTICS

Parameter Symbols		Description	Test Setup	Am27C010									Unit
JEDEC	Standard			-45	-55	-70	-90	-120	-150	-200	-255		
$t_{AVQV}$	$t_{ACC}$	Address to Output Delay	CE#, OE# = $V_{IL}$	Max	45	55	70	90	120	150	200	250	ns
$t_{ELQV}$	$t_{CE}$	Chip Enable to Output Delay	OE# = $V_{IL}$	Max	45	55	70	90	120	150	200	250	ns
$t_{GLQV}$	$t_{OE}$	Output Enable to Output Delay	CE# = $V_{IL}$	Max	25	35	35	40	50	65	75	75	ns
$t_{EHQZ}$ $t_{GHQZ}$	$t_{DF}$ (Note 2)	Chip Enable High or Output Enable High to Output High Z, Whichever Occurs First		Max	25	25	25	25	35	35	40	40	ns
$t_{AXQX}$	$t_{OH}$	Output Hold Time from Addresses, CE# or OE#, Whichever Occurs First		Min	0	0	0	0	0	0	0	0	ns

**Caution:** Do not remove the device from (or insert it into) a socket or board that has  $V_{PP}$  or  $V_{CC}$  applied.

**Notes:**

- $V_{CC}$  must be applied simultaneously or before  $V_{PP}$  and removed simultaneously or after  $V_{PP}$
- This parameter is sampled and not 100% tested.
- Switching characteristics are over operating range, unless otherwise specified.
- See Figure 3 and Table 1 for test specifications.

## SWITCHING WAVEFORMS

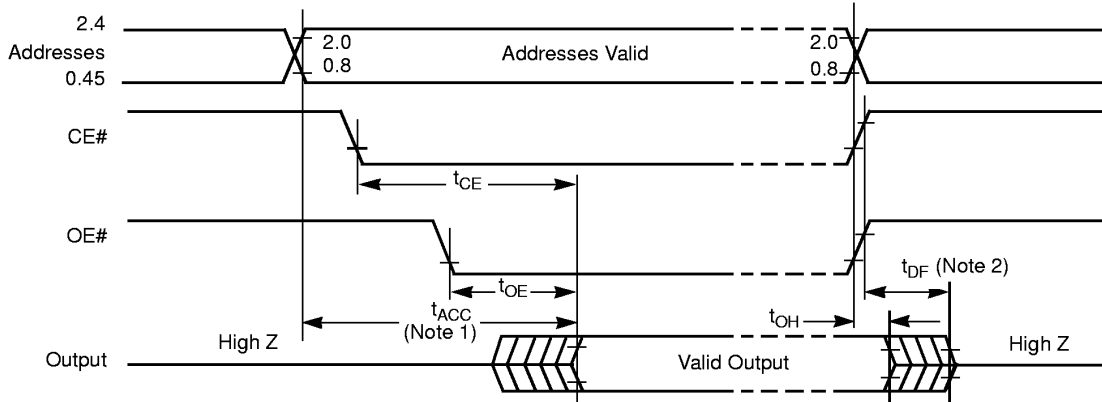

**Notes:**

- OE# may be delayed up to  $t_{ACC} - t_{OE}$  after the falling edge of the addresses without impact on  $t_{ACC}$
- $t_{DF}$  is specified from OE# or CE#, whichever occurs first.

## PACKAGE CAPACITANCE

Parameter Symbol	Parameter Description	Test Conditions	CDV032		PL 032		PD 028		Unit
			Typ	Max	Typ	Max	Typ	Max	
$C_{IN}$	Input Capacitance	$V_{IN} = 0$	9	12	8	12	8	12	pF
$C_{OUT}$	Output Capacitance	$V_{OUT} = 0$	13	15	11	14	11	14	pF

**Notes:**

- This parameter is only sampled and not 100% tested.
- $T_A = +25^\circ C$ ,  $f = 1$  MHz.

Rochester Electronics guarantees performance of its semiconductor products to the original OEM specifications. "Typical" values are for reference purposes only. Certain minimum or maximum ratings may be based on product characterization, design, simulation, or sample testing. Rochester Electronics reserves the right to make changes without further notice to any specification herein.