

ПРОМЫШЛЕННЫЙ МОНИТОР SCM 1570-R

Overview

Applications

- PC with VGA, SVGA, XGA;

Accessories

Included in delivery:

- AC power cable
- Video cable (fixed to monitor)



Features

- 38 cm (15") multisync color monitor
- Horizontal frequency 30 to 69 kHz
- Recommended resolution 800 x 600 at 75/85 Hz, max. 1024 x 768 at 75/80 Hz
- Industrial design in 19" format with 7 HU (standard height units)
- Degree of protection IP 54 (front)
- OSD (On Screen Display)

Информация для заказа

6GF6130-6MC	SCM 1570-R; FARBMONITOR 15", RACK-EINBAU 19" / 7 HE; 30-69HZ, 50-120 HZ, 80 MHZ; CROMACLEAR, OPTIMALE AUFLÖSUNG 800X600/100 HZ; ON SCREEN DISPLAY, POWER-MANAGEMENT, MPR II; TCO 92; IP 54 FRONTSEITIG, 1 ST
-------------	--

Технически характеристики

Параметр	Значение
Connection data Mains voltage Mains frequency Power consumption Isolation between electronics ground and protective earth (PE) Signal connection Plug and Play	90 to 260 VAC 50 / 60 Hz Max. 80 W No Video cable 15-pin/3-row Sub-D DDC 1, DDC 2B
CRT Diagonal Dot pitch Convergence error, center Convergence error, edge Degaussing	38 cm (15") 0.25 mm CROMACLEAR < 0.3 mm < 0.4 mm Automatic and manual
Synchronization Horizontal frequency Vertical frequency Sync signals	30 to 69 kHz 50 to 120 Hz Analog RGB, H/V separate, TTL positive/negative
Display Frequency response Useful screen area Resolution Standards	110 MHz 260 mm x 195 mm Max. 1024 x 768 at 75/85 Hz, optimum: 800 x 600 at 75/85 Hz VGA, SVGA
Controls Front Other	Power on/off Service key +/- Setting key +/- <u>Functions via OSD:</u> Brightness, contrast, geometry, color temperature, several languages, degaussing, moving of OSD, recall
Tests and certificates Temperature - Operation - Transport and storage Degree of protection to EN 60529 Safety, EMC Standards	0 to 50 °C with 30 % to 80 % humidity - 20 to + 60 °C with 10 % to 90 % humidity IP 54 (front) EN 60950, EN 50081-2, EN 50082-2 CE, LGA/GS, MPR II, UL (in preparation)
Mechanical design Housing, color Dimensions (W x H x D) in mm Weight, approx.	Aluminium, front "laght basic" 483 x 310 x 390 (19", 7 HU) 22 kg

SCM 1570-R, rack-mounted monitor, dimensions

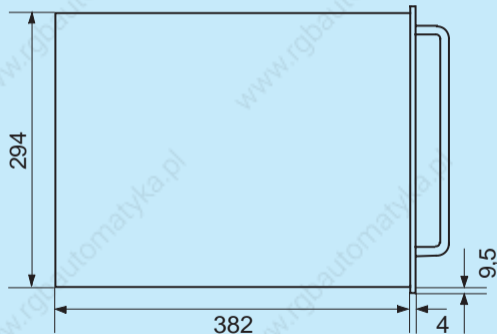
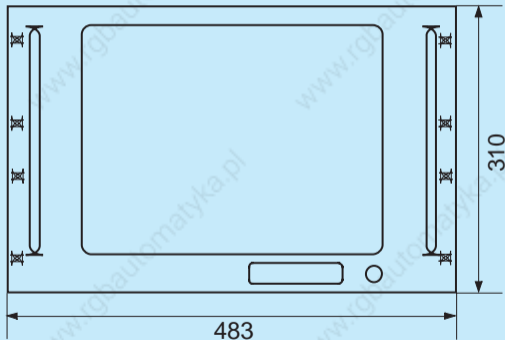

ПРОМЫШЛЕННЫЙ МОНИТОР SCM 1795-R

Overview

Applications

- PC with VGA, SVGA, XGA graphics

Accessories

Supplied with the monitor:

- AC power cable
- Video cable (5 x BNC, Sub-D)

To be ordered separately (on request):

- Touch screen
- Degree of protection IP 65 (upgrading package)



Features

- 43 cm (17") multisync color monitor
- 30 to 95 kHz
- Opt. resolution (VESA) 1024 x 768 pixels / 100 Hz
- Max. resolution 1600 x 1200, non-interlaced
- 0.26 mm shadow mask, black matrix
- OSD (On Screen Display)
- Low radiation emission to MPR II
- Industry-compatible design in 19" format with 8 HU
- Degree of protection IP 54

Информация для заказа

6GF6120-3MC	SCM 1795-R, FARBMONITOR 17" RACK-EINBAU 19"/8HE, 30-95KHZ, 50-150HZ, 135 MHZ, 1280X1024, FUNKTIONEN UEBER OSD, POWERMANAGEMENT, MPR II, MPR II, TCO 92, IP54 FRONTSEIT. M. TOUCH KAPAZITIV ODER RESISTI BITTE IM BESTELLTEXT ANGEBEN, 1 ST	WITH TOUCH-SCREEN
6GF6120-5MC	SCM 1795-R9/IP65, FARBMONITOR 17", RACK-EINBAU 19"/9HE, MIT KONTRASTSCHEIBE, MIT EINBAU-DICHTUNG, 30-95 KHZ, 50-150 HZ, 135 MHZ, 1280X1024, FUNKTIONEN UEBER OSD, POWERMANAGEMENT, MRP II, TCO 92, IP 65 FRONTSEITIG, 1 ST	IP 65
6GF6120-6MC	SCM 1795-R FARMONITOR 17" RACK-EINBAU 19"/8HE 30-95KHZ 50-150 HZ,135 MHZ1280 X1024, FUNKTION UEBER OSD, POWERMANAGEMENT MPRII, TCO, IP 54 FRONTSEITIG, 1 ST	IP 54

Технические характеристики

Параметр	Значение
Connection data Mains voltage Mains frequency Power consumption, nominal value Isolation between electronics ground and PE Signal connection Loop-through outputs	AC 110 to 240 V 50 / 60 Hz 120 W No 5 x BNC, 15-pin/3-row Sub-D socket No
CRT Diagonal Dot pitch Anti-glare method Persistence Convergence error, center Convergence error, edge Degaussing Max. resolution	43 cm (17"), black matrix 0.26 mm Non-glare, anti-static coating Short < 0.3 mm < 0.4 mm Automatic and manual 1600 x 1200 (non-interlaced)
Synchronization Horizontal frequency Vertical frequency Sync signals	30 to 95 kHz 50 to 150 Hz Analog R, G, B, H/V separate, H/V composite, SYNC on green
Display Standards Max. video bandwidth	VGA, SVGA, XGA, 1024 x 768, 1280 x 1024, 1600 x 1200 135 MHz
Controls Front Other	Power on/off (LED operating mode, standby) menu +/- setting key +/- Enter <u>Functions shown on LCD:</u> Brightness, contrast, H-size, H-position, V-size, V-position, color temperature, pin-cushion, parallelogram, trapezoid, picture rotation, display of resolution, H and V frequencies, movable OSD, recall, degauss, moire
Tests and certificates Temperature - Operation - Transport and storage Degree of protection to EN 60 529 Standards	0 to 50 °C at 30 % to 80 % humidity - 20 to + 60 °C at 10 % to 90 % humidity IP 54 (front) CE, LGA/GS, MPR II, FCC class A, (UL and cUL in preparation)
Mechanical design Housing, color Dimensions (W x H x D) in mm Weight, approx.	Aluminium, front "light basic" 483 x 355 x 464 (19", 8 HU) 22 kg

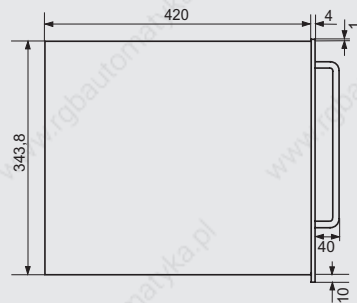
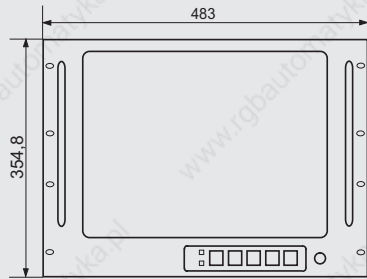

Dimensions SCM 1795-R

ПРОМЫШЛЕННЫЙ МОНИТОР SCM 1995-R

Overview

Applications

- PC with VGA, SVGA, XGA graphics

Accessories

Supplied with the monitor:

- AC power cable
- Video cable

To be ordered separately (on request):

- Touch screen



Features

- 49 cm (19") multisync color monitor
- Horizontal frequency 30 to 95 kHz
- Opt. resolution (VESA) 1024 x 768 pixels / 100 Hz
- Max. resolution 1600 x 1200, non-interlaced
- 0.25 mm shadow mask, black matrix
- OSD (On Screen Display)
- Low radiation emission to MPR II
- Industry-compatible design in 19" format with 9 HU
- Degree of protection IP 65

Информация для заказа

6GF6110-3MC	SCM 1995-R,FARBMONITOR 19"/9HE 30-95KHZ, 50-150HZ, 135 MHZ, 1600X1200, OSD, POWERMA., MRP II, IP65(FRONT) M. TOUCH KAPAZITIV ODER RESITIV, BITTE IM BESTELLTEXT ANGEBEN, 1 ST	WITH TOUCHSCREEN
6GF6110-6MC	SCM 1995-R FARBMONITOR 19" RACK-EINBAU 19"/9HE, 30-95KHZ 50-150HZ, 135 MHZ, 1600X1200 FUNKTIONEN UEBER OSD, POWERMANAGEMENT, MPRII, IP65 FRONTSEITIG, 1 ST	

Технические характеристики

Параметр	Значение
Connection data Mains voltage Mains frequency Power consumption, nominal value Isolation between electronics ground and PE Signal connection Loop-through outputs	AC 110 to 240 V 50 / 60 Hz 130 W No 5 x BNC, 15-pin/3-row Sub-D socket No
CRT Diagonal Dot pitch Anti-glare method Persistence Convergence error, center Convergence error, edge Degaussing Max. resolution	49 cm (19"), black matrix 0.25 mm Non-glare, anti-static coating Short < 0.3 mm < 0.4 mm Automatic and manual 1600 x 1200 (non-interlaced)
Synchronization Horizontal frequency Vertical frequency Sync signals	30 to 95 kHz 50 to 150 Hz Analog R, G, B, H/V separate, H/V composite, SYNC on green
Display Standards Max. video bandwidth	VGA, SVGA, XGA, 1024 x 768, 1280 x 1024, 1600 x 1200 135 MHz
Controls Front Other	Power on/off (LED operating mode, standby) menu +/- setting key +/- Enter <u>Functions shown on LCD:</u> Brightness, contrast, H-size, H-position, V-size, V-position, color temperature, pin-cushion, parallelogram, trapezoid, picture rotation, display of resolution, H and V frequencies, movable OSD, recall, degauss, moire
Tests and certificates Temperature - Operation - Transport and storage Degree of protection to EN 60 529 Standards	0 to 50 °C at 30 % to 80 % humidity - 20 to + 60 °C at 10 % to 90 % humidity IP 65 (front) CE, LGA/GS, MPR II, FCC class A, (UL and cUL in preparation)
Mechanical design Housing, color Dimensions (W x H x D) in mm Weight, approx.	Aluminium, front "light basic" 483 x 399 x 512 (19", 9 HU) 32 kg

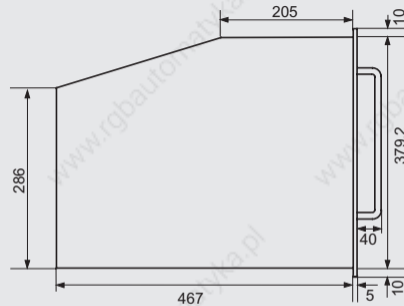
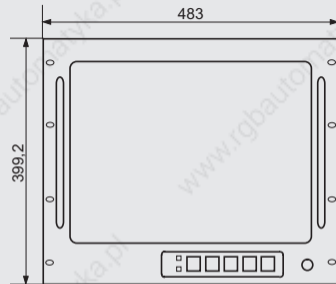

Dimensions SCM 1995-R

Siemens KT 61

ПРОМЫШЛЕННЫЙ НАСТОЛЬНЫЙ МОНИТОР SCM 2196-I

Applications

The digital, high-resolution color monitor SCM 2196-I is distinguished by its versatile application possibilities when used together with computers, e.g. in archiving systems, for daylight applications and in medical technology. High-contrast, sharp pictures through ARAS multiple anti-glare coating and stable color reproduction (automatic cut-off) are important features of the monitor.



The SCM 2196 color monitor is provided with a dispenser cathode which increases the lifetime of the picture tube and reduces the costs of the video workstation. The contrast is automatically adjusted to suit room brightness; this saves energy and achieves an optimum and restful display. The ergonomic, compact design of the monitor with ventilation slots on the sides prevents the penetration of dust and liquids from above.

Accessories

Supplied With the monitor:

- AC power cable
- Video cable
- Tilt and swivel stand
- Instruction manual

Features

- Multistandard operation (up to 19 standards can be stored)
- 54 cm (21") CRT with a resolution > 100 dpi
- Horizontal frequencies from 30 to 96 kHz, vertical frequencies from 50 to 120 Hz
- Resolution up to 1600 x 1200 pixels (VGA, SVGA, XGA, *inter alia*)
- Degree of protection IP 30, ventilation slits only on sides and at bottom
- Electrical isolation between video ground and protective earth
- 24-hour automatic degaussing for continuous operation
- Cut-off control for constant color quality on aging of CRT
- Ambient light sensor for automatic contrast control
- Connection of triax cables (double-screened)
- Power down management (VESA-DPSM)
- Adjustable with balance (6500 K, 7500 K, 9300 K, user)

Технические характеристики

Параметр	Значение
Connection data Mains voltage Mains frequency Power consumption Signal connection	AC 94 to 264 V 47 to 63.6 Hz Approx. 150 W, power factor correction to IEC 1000 5 x BNC
CRT Type Dot pitch Type of phosphor Surface Convergence error	54 cm (21") flat & square, PIL, INVAR mask , black matrix, longer service life as result of dispenser cathode 0.28 mm (0.22 mm horizontal) P22; persistence: short to medium Multicoating for anti-glare screen, antistatic panel to prevent static charging < 0.4 mm
Synchronization Horizontal frequency Vertical frequency Video timings Sync signals	30 to 96 kHz 50 to 120 Hz Max. 19 can be stored (self-recognizing) RGB with separate H and V SYNC, RGBC with CSYNC on H SYNC line RGB with SYNC on green
Display Focussing High-voltage Frequency response Display area (W x H) Luminance with 100% white screen Luminance with area 10 cm x 10 cm Color temperature Color stability Contrast control Resolution Standards	Static and dynamic 27.5 kV, stabilized, with protective circuit 120 MHz (BNC) 380 mm x 285 mm Max. 80 cd/m ² Max. 120 cd/m ² 9300 K/7500 K/6500 K and user-specific Automatic cut-off control External light sensor Max. 1600 x 1200 / 75 Hz 1280 x 1024 / 85 Hz VGA, ErgoVGA, SVGA, 8514/A, MAC II, XGA, etc.
Controls Front (membrane keyboard) Rear	Keys for power on/off, brightness +/-, contrast +/- and adjustment 75 Ω selectable (R, G, B, H)
Tests and certificates Safety	UL 1950, CSA C22.2 No. 950 VDE 0805/EN 60950/IEC 950, CE

Параметр	Значение
Protection class	1
Degree of protection	IP 30, ventilation slots on sides and bottom only (industrial)
Electromagnetic radiation	MPR II, VDE 0878 limit class B FCC class A, IEC 601
Temperature range	10 °C to 35 °C
Mechanical design	
Housing, color	Plastic, ergo gray
Material	Recyclable, CFC-free design
Dimensions (W x H x D) in mm	499 x 480 x 520
Weight, approx.	30.5 kg

Информация для заказа

6GF6100-1BA	SCM 2196-I; FARBMONITOR 21"; 30-96 KHZ; 120 MHZ; 1600X1200; LANGLEBENDE BILDROEHRE; 24 STD. DEGAUSS; POTENTIALTRENNUNG; IP30, OBERSEITE GESCHLOSSEN; POWERMANAGEMENT; CUT-OFF; MPR II, 1 ST	
6GF6100-3BA	SCM 2196-TOUCH, FARBMONITOR 21" TESCHNISCHE DATEN WIE SCM 2196, MIT FEST AUFGEKLEBTER TOUCHSCHE KAPAZITIVES VERFAHREN, 1 ST	WITH TOUCH-SCREEN