

Standard Industrial types **RI 58-D / RI 58TD**

Incremental

Hollow shaft



Clamping shaft



Blind shaft

- Direct mounting without coupling
- Flexible hollow shaft design up to diameter 14 mm
- Through hollow shaft or as end shaft (blind shaft)
- Easy installation by means of clamping shaft or blind shaft
- Short overall length of 33 mm
- Fixing of flange by means of a stator coupling or set screw
- Various shaft versions
- Applications: actuators, motors
- Operating temperature up to 100 °C (RI 58TD)



NUMBER OF PULSES RI 58-D

1 / 2 / 3 / 4 / 5 / 10 / 20 / 25 / 30 / 35 / 40 / 45 / 50 / 60 / 64 / 70 / 72 / 80 / **100** / 125 / 128 / 144 / 150 / 180 / 200 / **250** / 256 / 300 / 314 / 350 / 360 / 375 / 400 / 460 / 480 / **500** / 512 / 600 / 625 / 720 / 900 / **1000** / **1024** / **1250** / 1500 / 1600 / 1800 / 2000 / 2048 / **2500** / 3000 / 3480 / **3600** / 4000 / **4096** / **5000**

Other number of pulses on request
Preferably available versions are printed in bold type.

NUMBER OF PULSES RI 58TD

4 / 5 / 10 / 20 / 25 / 30 / 35 / 40 / 45 / 50 / 60 / 64 / 70 / 72 / 80 / **100** / 125 / 128 / 144 / 150 / 180 / 200 / **250** / 256 / 300 / 314 / 350 / 360 / 375 / 400 / 460 / 480 / **500** / 512 / 600 / 625 / 720 / 900 / **1000** / **1024** / **1250** / 1500 / 1600 / 1800 / 2000 / 2048 / **2500**

Other number of pulses on request
Preferably available versions are printed in bold type.

TECHNICAL DATA
mechanical

Housing diameter	58 mm
Shaft diameter ¹	10 mm / 12 mm (Through hollow shaft) 10 mm / 12 mm / 14 mm (Hubshaft)
Flange (Mounting of housing)	Synchro flange
Mounting of shaft	RI 58-D: Front clamping ring, Center bolt RI 58TD: Front clamping ring, Rear clamping ring, Center bolt
Protection class shaft input (EN 60529)	IP64
Protection class housing (EN 60529)	Through hollow shaft - D: IP64 Hubshaft - E,F: IP65

TECHNICAL DATA
mechanical (continued)

TECHNICAL DATA
electrical

Standard Industrial types **RI 58-D / RI 58TD**

Incremental

Hollow shaft

Shaft tolerance	Ø 10 mm, tolerance g8 (-0.005 ... -0.027 mm), Ø 12/ 14 mm, tolerance g8 (-0.006 ... -0.033 mm)
Max. speed	Hub shaft - E,F: max. 6000 rpm Through hollow shaft - D: max. 4000 rpm
Starting torque typ.	≤ 1 Ncm (Hub shaft - E,F) ≤ 2 Ncm (Through hollow shaft - D)
Moment of inertia	approx. 35 gcm ² (Hub shaft with clamping ring front - F) approx. 20 gcm ² (Hub shaft, mountig with set screw - E) approx. 60 gcm ² (Through hollow shaft with clamping ring front - D)
Vibration resistance (DIN EN 60068-2-6)	10 g = 100 m/s ² (10 ... 2000 Hz)
Shock resistance (DIN EN 60068-2-27)	100 g = 1000 m/s ² (6 ms)
Operating temperature	RI 58-D: -10 °C ... +70 °C RI 58TD: -25 °C ... +100 °C
Storage temperature	-25 °C ... +85 °C
Material housing	Aluminum
Weight	approx. 170 g with hubshaft (E,F), approx. 190 g with trough hollow shaft (D)
Connection ²	Cable, axial or radial M23 connector (Conin), radial

¹ Other shaft diameters on request

² Standard cable length: 1.5 m cable, other cable length on request (only RI 58TD)

General design	as per DIN VDE 0160, protection class III, contamination level 2, overvoltage class II
Supply voltage ¹	RS422 + Sense (T): DC 5 V ±10 % RS422 + Alarm (R): ± 10% DC 5 V or DC 10 - 30 V Push-pull (K), Push-pull antivalent (I): DC 10-30 V
Current w/o load typ.	40 mA (DC 5 V), 60 mA (DC 10 V), 30 mA (DC 24 V)
Max. pulse frequency	RS422: 300 kHz Push-pull: 200 kHz
Standard output versions ²	RS422 + Alarm (R): A, B, N, \bar{A} , \bar{B} , \bar{N} , \bar{Alarm} RS422 + Sense (T): A, B, N, \bar{A} , \bar{B} , \bar{N} , Sense Push-pull (K): A, B, N, \bar{Alarm} Push-pull complementary (I): A, B, N, \bar{A} , \bar{B} , \bar{N} , \bar{Alarm}
Pulse width error	± max. 25° electrical
Number of pulses	1 ... 5000
Alarm output	NPN-O.C., max. 5 mA
Pulse shape	Square wave
Pulse duty factor	1:1

¹ With push-pull (K): pole protection

² Output description and technical data see chapter "Technical basics"

Incremental Hollow shaft

MOUNTING NECESSITIES

In order to be able to compensate an axial and radial misalignment of the shaft, the encoder flange must not be fixed rigidly. Fix the flanges by means of a stator coupling (e.g. hubshaft with tether) as torque support (see "Accessories") or by means of a cylindrical pin:

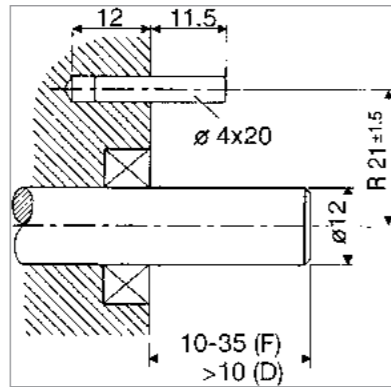

Dimensions in mm also apply for shaft-Ø 10 or 14
Mounting = D, F (Clamping ring)
Preparation of the machine flange ¹

(all mounting versions):

In the machine flange a straight pin must be installed (diameter 4x16 resp. 4x20, DIN 6325).
This pin is required as a torque support.

1 Or as an option: stator coupling as torque support

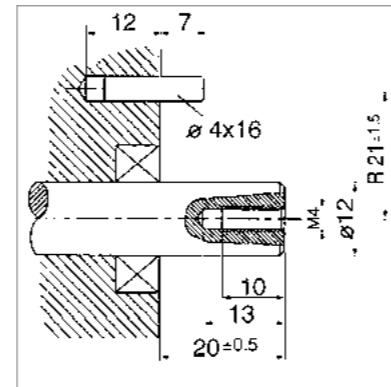

Dimensions in mm also apply for shaft-Ø 10 or 14
Mounting = E (mounting with center screw)
Preparation of the drive shaft

(only in mounting = E):

The drive shaft must be provided with a threaded bore M 4 x 10:
This bore accepts the fastening screw of the shaft encoder.

**ELECTRICAL CONNECTIONS
Cable PVC**

Cable PVC Colour	Output circuit			
	RS422 + Sense (T)	RS422 + Alarm (R)	push-pull (K)	push-pull complementary (I)
white	Channel A	Channel A	Channel A	Channel A
white/brown	Channel \bar{A}	Channel \bar{A}		Channel \bar{A}
green	Channel B	Channel B	Channel B	Channel B
green/brown	Channel \bar{B}	Channel \bar{B}		Channel \bar{B}
yellow	Channel N	Channel N	Channel N	Channel N
yellow/brown	Channel \bar{N}	Channel \bar{N}		Channel \bar{N}
yellow/black	Sense GND	$\bar{A}larm$	$\bar{A}larm$	$\bar{A}larm$
yellow/red	Sense V _{cc}	Sense V _{cc}		Sense V _{cc}
red	DC 5 V	DC 5 / 10 - 30 V	DC 10 - 30 V	DC 10 - 30 V
black	GND	GND	GND	GND
Cable screen ¹	Cable screen ¹	Cable screen ¹	Cable screen ¹	Cable screen ¹

¹ connected with encoder housing

**ELECTRICAL CONNECTIONS
Cable TPE**

**ELECTRICAL CONNECTIONS
M23 connector (Conin), 12 pole**

Incremental Hollow shaft

Cable TPE Colour	Output circuit			
	RS422 + Sense (T)	RS422 + Alarm (R)	push-pull (K)	push-pull complementary (I)
brown	Channel A	Channel A	Channel A	Channel A
green	Channel \bar{A}	Channel \bar{A}		Channel \bar{A}
grey	Channel B	Channel B	Channel B	Channel B
pink	Channel \bar{B}	Channel \bar{B}		Channel \bar{B}
red	Channel N	Channel N	Channel N	Channel N
black	Channel \bar{N}	Channel \bar{N}		Channel \bar{N}
violet (white) ¹	Sense GND	$\bar{A}larm$	$\bar{A}larm$	$\bar{A}larm$
blue	Sense V _{cc}	Sense V _{cc}		Sense V _{cc}
brown/green	DC 5 V	DC 5 / 10 - 30 V	DC 10 - 30 V	DC 10 - 30 V
white/green	GND	GND	GND	GND
Cable screen ²	Cable screen ²	Cable screen ²	Cable screen ²	Cable screen ²

¹ white with RS422 + Sense (T)

² connected with encoder housing

Pin	RS422 + Sense (T)	RS422 + Alarm (R)	push-pull (K)	push-pull complementary (I)
1	Channel \bar{B}	Channel \bar{B}	N.C.	Channel \bar{B}
2	Sense V _{cc}	Sense V _{cc}	N.C.	Sense V _{cc}
3	Channel N	Channel N	Channel N	Channel N
4	Channel \bar{N}	Channel \bar{N}	N.C.	Channel \bar{N}
5	Channel A	Channel A	Channel A	Channel A
6	Channel \bar{A}	Channel \bar{A}	N.C.	Channel \bar{A}
7	N.C.	$\bar{A}larm$	$\bar{A}larm$	$\bar{A}larm$
8	Channel B	Channel B	Channel B	Channel B
9	N.C. ¹	N.C. ¹	N.C. ¹	N.C. ¹
10	GND	GND	GND	GND
11	Sense GND	N.C.	N.C.	N.C.
12	DC 5 V	DC 5/10 - 30 V	DC 10 - 30 V	DC 10 - 30 V

¹ screen for cable with CONIN connector

Standard Industrial types RI 58-D / RI 58TD
Incremental Hollow shaft

DIMENSIONED DRAWINGS

Mounting F: Hubshaft with clamping ring front

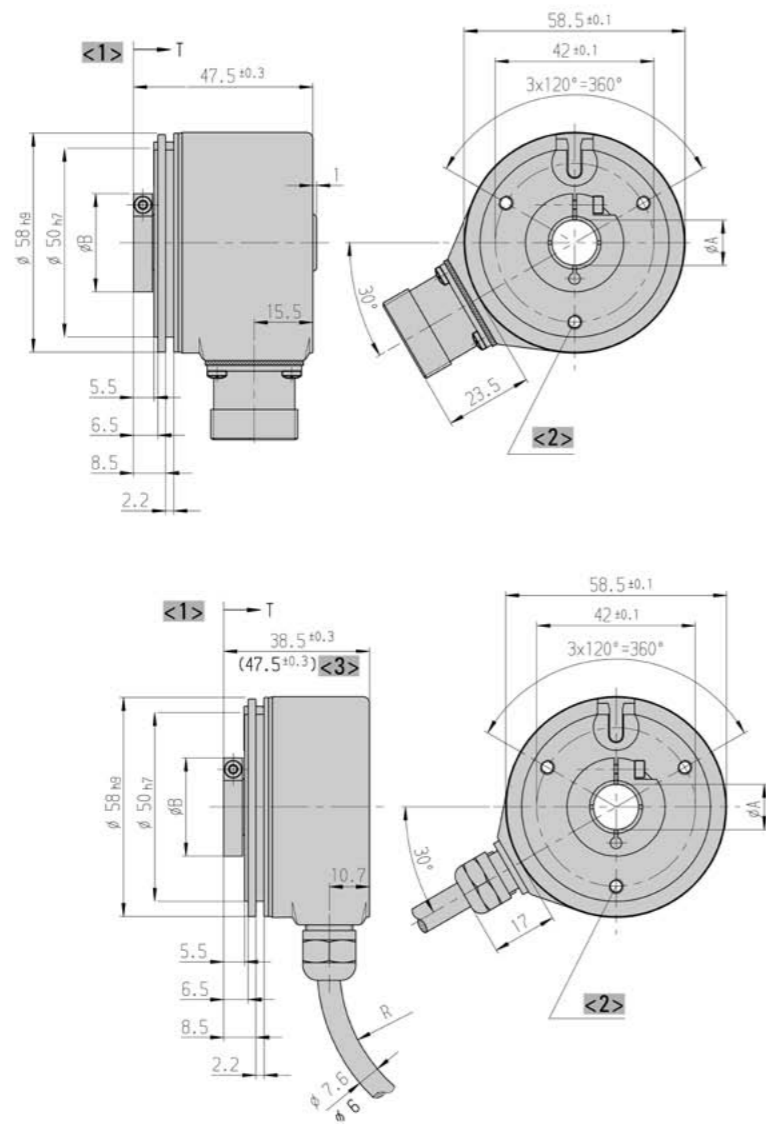

Dim.	Hollow shaft Ø			Unit
A	10 ^{H7}	12 ^{H7}	14 ^{H7}	mm
A*	10 ^{g8}	12 ^{g8}	14 ^{g8}	mm
B	26	28	30	mm
T	33.5	33.5	22.5	mm

A* = diameter of connection shaft

<1> View turned 60°
 <2> mounting thread M4x5
 <3> value in brackets with version DC 10 - 30 V, RS422
 Cable bending radius R for flexible installation ≥ 100 mm
 Cable bending radius R for fixed installation ≥ 40 mm

Dimensions in mm

Standard Industrial types RI 58-D / RI 58TD
Incremental Hollow shaft

DIMENSIONED DRAWINGS (continued)

Mounting D: Through hollow shaft with clamping ring front

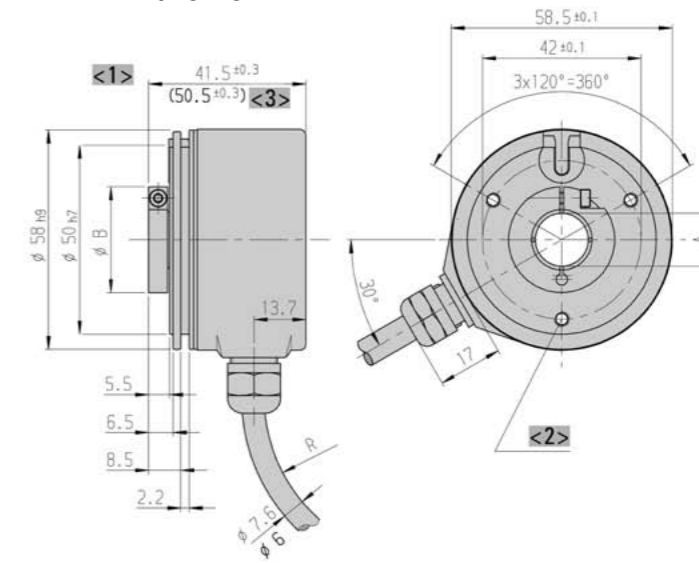

Dim.	Hollow shaft Ø		Unit
A	10 ^{H7}	12 ^{H7}	mm
A*	10 ^{g8}	12 ^{g8}	mm
B	26	28	mm

A* = diameter of connection shaft

<1> View turned 60°
 <2> mounting thread M4x5
 <3> value in brackets with version DC 10 - 30 V, RS422
 Cable bending radius R for flexible installation ≥ 100 mm
 Cable bending radius R for fixed installation ≥ 40 mm

Dimensions in mm

Mounting H optional: Through hollow shaft with clamping ring rear on request

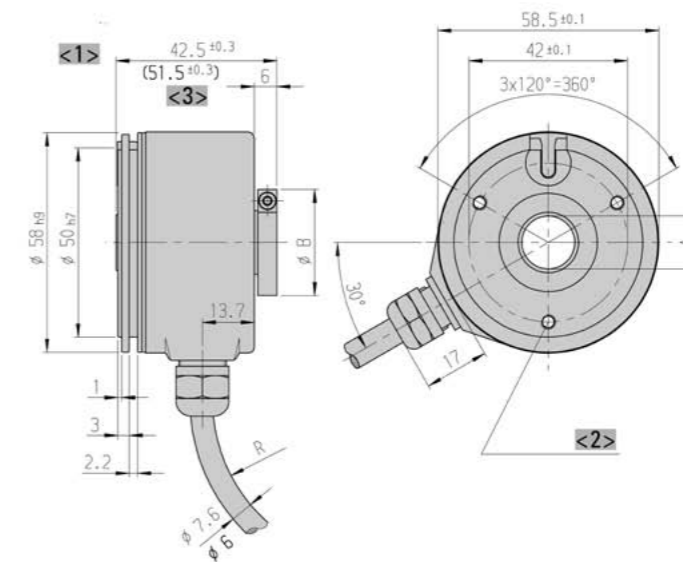

Dim.	Hollow shaft Ø		Unit
A	10 ^{H7}	12 ^{H7}	mm
A*	10 ^{g8}	12 ^{g8}	mm
B	26	28	mm

A* = diameter of connection shaft

<1> View turned 60°
 <2> mounting thread M4x5
 <3> value in brackets with version DC 10 - 30 V, RS422
 Cable bending radius R for flexible installation ≥ 100 mm
 Cable bending radius R for fixed installation ≥ 40 mm

Dimensions in mm

Standard Industrial types RI 58-D / RI 58TD
Incremental Hollow shaft

DIMENSIONED DRAWINGS (continued)

Mounting E: Hubshaft, mounting with center screw

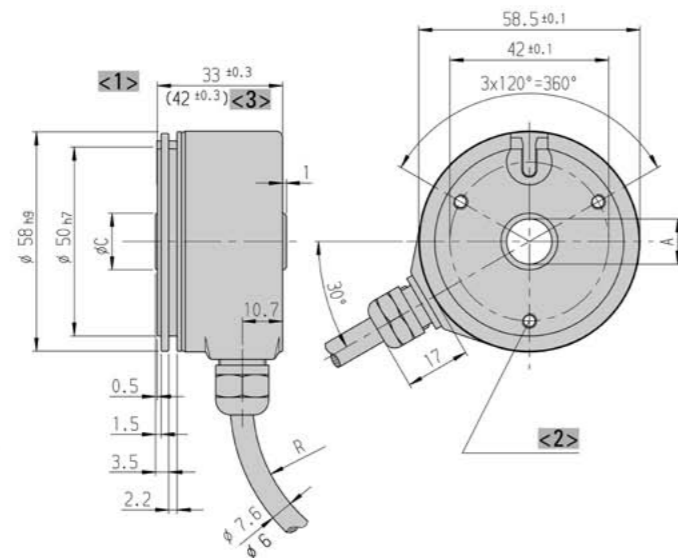
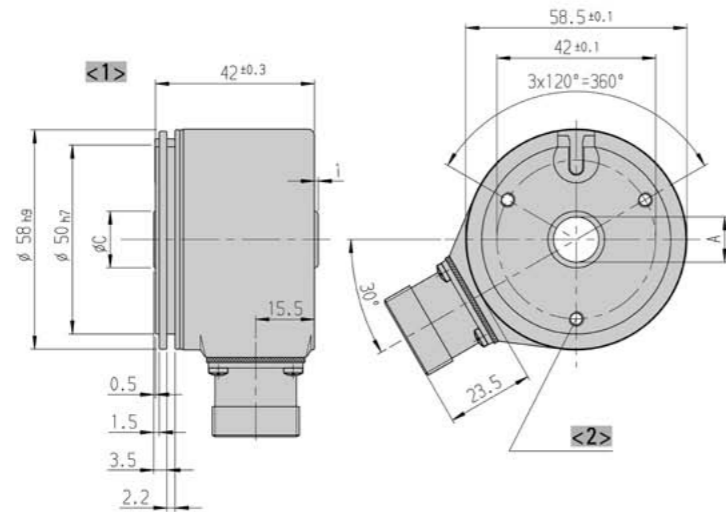

Dim.	Hollow shaft Ø			Unit
A	10 ^{H7}	12 ^{H7}	14 ^{H7}	mm
A*	10 ^{g8}	12 ^{g8}	14 ^{g8}	mm
C	15	15	17	mm
T	18±0.5	18±0.5	18±0.5	mm

A* = diameter of connection shaft
 T = length of custom shaft in encoder

<1> View turned 60°
 <2> mounting thread M4x5
 <3> value in brackets with version DC 10 - 30 V, RS422
 Cable bending radius R for flexible installation ≥ 100 mm
 Cable bending radius R for fixed installation ≥ 40 mm

Dimensions in mm

Standard Industrial types RI 58-D / RI 58TD
Incremental Hollow shaft

ORDERING INFORMATION

Type	Number of pulses	Supply voltage	Flange, Protection, Shaft ³	Output	Connection
<input type="checkbox"/>	<input type="checkbox"/>	<input type="checkbox"/>	<input type="checkbox"/>	<input type="checkbox"/>	<input type="checkbox"/>
RI58-D RI58TD	1 ... 5000	A DC 5 V¹ E DC 10 - 30 V²	D.32 Through hollow shaft with clamping ring front, IP64, 10 mm D.37 Through hollow shaft with clamping ring front, IP64, 12 mm E.42 Hubshaft, mounting with set screw, IP64, 10 mm E.47 Hubshaft, mounting with set screw, IP64, 12 mm E.49 Hubshaft, mounting with set screw, IP64, 14 mm F.42 Hubshaft, mounting with clamping ring front, IP64, 10 mm F.47 Hubshaft, mounting with clamping ring front, IP64, 12 mm F.49 Hubshaft, mounting with clamping ring front, IP64, 14 mm	R RS422 +Alarm T RS422 +Sense K Push-pull I Push-pull complementary	B PVC cable, radial F TPE cable, radial D M23 connector (Conin), 12 pole, radial, cw H M23 connector (Conin), 12 pole, radial, ccw

¹ DC 5 V: only with output "T", "R" available

² DC 10 - 30 V: only with output "K", "I", "R" available

³ Mounting (flange) code "D" only with connection code "B", "F" (cable)

ORDERING INFORMATION
 Selection of cable length

Versions with cable outlet (connection A, B, E or F) are available with various lengths of cable. To order your desired cable length, please add the respective code to the end of your ordering code. For variants with connector on cable end please add cable length code in between. Further cable lengths on request.

Code	Cable length
without code	1.5 m
-D0	3 m
-F0	5 m
-K0	10 m
-P0	15 m
-U0	20 m
-V0	25 m

Example:
 Cable 3 m length: ... B - D0
 Cable mit 3 m length and M23 connector, cw: ... B - D0 - I

ACCESSORIES

see chapter "Accessories"