



MEASUREMENT AND CONTROL

JUMO DICON S Universal Compact Controller for industrial and process control

Housing to DIN 43 700 for flush panel mounting

Bezel 96 x 96 mm



B 70.3530 (D 97.550)

2.90/V 00074175

Operating Instructions

M. K. JUCHHEIM GMBH & CO · 36035 Fulda · GERMANY
Phone (06 61) 60 03-0 · Telefax (06 61) 60 03-6 07 · Telex 4 9 701 juf d

CONTENTS

Contents

	Page
1 DESCRIPTION	1
1.1 Type designation	2
1.2 Indications and controls	4
2 TECHNICAL DATA	5
3 INSTALLATION	9
3.1 Location and climatic conditions	9
3.2 Fitting in position	9
3.3 Dimensions	9
4 ELECTRICAL CONNECTION	10
4.1 Connection diagram	10
4.2 Important notes on installation	12
5 OPERATION	13
5.1 Planes and blockages	13
5.2 Display	14
5.3 Displaying process and setpoint and changing the setpoint	14
5.4 Manual operation	15
6 PARAMETER PLANE	16
6.1 Displaying and changing parameters	16
6.2 Parameter Table	17
7 CONFIGURATION PLANE	18
7.1 Displaying configuration data	18
7.2 Changing configuration data	19
7.3 Configuration Table	20
8 ACTION ON FAULTS	27
8.1 Error messages	27
8.2 Action on supply failure	27
8.3 Action on failure or short-circuit of sensor	27
9 INTERNAL ADJUSTMENTS	28
10 ADDITIONAL FUNCTIONS	31
10.1 Meaning of the external contacts	31
10.2 Correction of process indication by user	32
10.3 Calibration of resistance transmitter for valve stroke retransmission (modulating controller)	32
10.4 Calibration of inputs 1 and 2 with current input 0/4 – 20 mA	32
10.5 Controller with ramp function	33
10.6 Function of logic inputs	36
10.7 Humidity controller	36
10.8 Ratio control	36
10.9 Compensation of external disturbance	36
11 OPTIMISATION	37

IMPORTANT NOTE

All necessary settings and, where appropriate, alterations are described in these Operating Instructions. If, however, any difficulties should arise during start-up you must not carry out any manipulation on the instrument which is not permitted. – You could endanger your rights under the instrument warranty. Please contact the nearest office or the main factory.

1 DESCRIPTION

The DICON S is a microprocessor controller which can be freely configured and therefore used universally. The unit has a 96 x 96 mm bezel and a depth of only 121.5 mm due to the use of the latest developments in electronics such as SMD technology.

The DICON S has a 4-digit numerical display and in addition a 4-character alphanumerical display which can be used either for comments on the displayed value or for indicating a second value. The unit can be operated as single or double setpoint controller, as modulating controller or as proportional controller. Three relay outputs are available as control or alarm contacts depending on the control mode selected.

The memory holds the linearisation for all standard sensors; a self-calibrating input circuit ensures an accuracy better than 0.1% with resistance thermometers, for example. Psychrometric humidity measurement is independent of reference temperature. All parameters of the DICON S can be configured, i.e. all controller data such as type and number of inputs, controller architecture, feedback action and interface details can be entered from the keys.

DICON S can be integrated into a data system through a V.24 (RS232C) or RS422/485 interface. DICON S is of modular construction and therefore particularly convenient to operate and service. The plug-in controller chassis readily permits servicing and retrofitting of options.

Surface-mounted devices (SMD) result in a high packing density in the DICON S together with extended functions and enhanced reliability.

The features of the DICON S

- Simple and user-friendly operation through clear functional separation:
 - OPERATE
 - PARAMETERS
 - CONFIGURE
- Blockable planes to protect against unintentional alteration
- Bright self-luminous displays:
 - 4-digit numerical LED display
 - 4-character alphanumerical LED displaydisplays can be freely configured
- Operation through membrane keys
- Can be configured as switching single-setpoint or double-setpoint controller, modulating controller or proportional controller
- Integral control station for bump-free auto/manual changeover
- 4 analogue inputs for: thermocouple, resistance thermometer, resistance transmitter, humidity sensor and current/voltage signals .
- Current transducers 0(4)–20 mA can be connected to resistance thermometer and thermocouple inputs via an external shunt (to special order)
- Analogue inputs can be used for ratio control, psychrometric humidity control, compensation of external disturbance, valve stroke retransmission, external setpoint selection, temperature difference control, indication of a second process variable, heater current indication/monitoring
- Two logic inputs, controlled by external floating contacts
- Free selection of setpoint limits
- Isolated voltage supply for 2-wire transducers
- V.24 (RS232C) or RS422/485 interface with full isolation
- Self-optimisation; on-off and proportional controller
- Ramp function
- Two analogue outputs with full isolation
- Three logic outputs
- Output signal for probe failure, can be configured

1 DESCRIPTION

1.1 Type designation

The type label is affixed to the housing. The type designation contains all the data on the controller function, the inputs and the Extra Codes. The mains supply must agree with the supply voltage on the label.

SR-96 / 5 - 053, 0, 0, 12 - 111 - 51

Compact controller
bezel 96 x 96 mm

Function: proportional controller

Input 1: current
4-20 mA

Input 2: not used

Input 3: not used

Input 4: external setpoint signal
4-20 mA

Logic outputs:
3 relay outputs for Xk1, 2 and 3

Interface: V.24 (RS232C)

JUMO MESSE UND REGELTECHNIK	
Type	SR-96/5-053,0,0,12-111-51
ME 1:	4...20mA
ME 2:	-----
ME 3:	-----
ME 4:	ext. "w" 4...20mA
A1:	"V" 0...20mA 5/6
A2:	660V/3A 20/31
A3:	660V/3A 30/31
A4:	660V/3A 40/41
U	220 V 2U V
T	50 40/60 Hz 15 VA
F.Nr.	89030029
SOFTWARE: 024.04.01	

Controller function

Description

Code

Single-setpoint controller with max. contact (relay de-energised for process above setpoint), action PD, PID or PD/PID¹⁾ and 2 limit comparators. Feedback action and limit comparators can be configured _____ 1

Single-setpoint controller with min. contact (relay de-energised for process below setpoint), action PD, PID or PD/PID¹⁾ and 2 limit comparators. Feedback action and limit comparators can be configured _____ 2

Double-setpoint controller with PD, PID or PD/PID action¹⁾ and 1 limit comparator. Feedback action and limit comparator can be configured _____ 3

Modulating controller with PI or PID action¹⁾ and 1 limit comparator. Feedback action and limit comparator can be configured _____ 4

Controller function

Description

Code

Proportional controller with P, PI, PD or PID action¹⁾ and 3 limit comparators. Output signal, characteristic and limit comparators can be configured _____ 5

¹⁾ The factory settings are shown in the parameter table on page 17

1 DESCRIPTION

Inputs	
Input 1 (Process signal)	Code
Resistance thermometers in 3-wire circuit	
Pt 100 _____	001
Pt 500 _____	002
Resistance thermometers in 4-wire circuit	
Pt 100 _____	011
Pt 500 _____	012
Resistance transmitters _____	021
Thermocouples	
Cu-Con T _____	039
Fe-Con J _____	040
Cu-Con U _____	041
Fe-Con L _____	042
NiCr-Ni K _____	043
Pt10Rh-Pt S _____	044
Pt13Rh-Pt R _____	045
Pt30Rh-Pt6Rh B _____	046
MoRe5 - MoRe41 _____	047
Linearised transducers	
0 - 1 mA _____	051
0 - 20 mA _____	052
4 - 20 mA _____	053
Linearised transducers	
0 - 50 mV _____	061
0 - 1 V _____	062
0 - 10 V _____	063
Non-linearised transducers	
0 - 1 mA (range _____) * 1 . . **	
0 - 20 mA (range _____) * 2 . . **	
4 - 20 mA (range _____) * 3 . . **	
Special range (range _____) * 900	
Non-linearised transducers	
0 - 50 mV (range _____) * 4 . . **	
0 - 1 V (range _____) * 5 . . **	
0 - 10 V (range _____) * 6 . . **	
Special range (range _____) * 900	
* specify in full ** the dots must be replaced by the last two digits of the thermocouple code, e.g.: Code 241 means input 0-20 mA and linearisation to Cu-Con.	
Input 2	Code
not in use _____	0
Temperature difference input _____ (sensors as input 1)	1
Indication of second process variable (sensor as input 1)	2
Reference temperature _____ (Pt 100 sensor in 3-wire or 4-wire circuit)	3
Heater current indication _____ (a.c. current 0 - 20 mA, 50 Hz)	4
Ratio input 0/4 - 20 mA _____	5
Humidity input (psychrometric) _____	6

Inputs	
Input 3	Code
not in use _____	0
Valve stroke retransmission resistance transmitter _____	1
Input 4	Code
Function of input:	
not in use _____	00
External setpoint selection _____	1.
External setpoint selection with \pm correction from the front _____	2.
External disturbance compensation _____	3.
input signal:	
0 - 20 mA _____	.1
4 - 20 mA _____	.2
0 - 10 V _____	.3

Logic outputs

Logic outputs	Code	Xk1	Xk2	Xk3
Relay 3 A _____	1	<input type="checkbox"/>	<input type="checkbox"/>	<input type="checkbox"/>
0/5 V or 0/20 mA _____	2	<input type="checkbox"/>	<input type="checkbox"/>	<input type="checkbox"/>
Semiconductor relay 1 A _____	3	<input type="checkbox"/>	<input type="checkbox"/>	<input type="checkbox"/>

Extra Codes

Analogue output 1	Code
(on-off controller)	
Function of output:	
Process x _____	1.
Setpoint w _____	2.
Deviation xw _____	3.
2nd process variable _____	4.
output signal:	
0 - 20 mA _____	.1
4 - 20 mA _____	.2
0 - 10 V _____	.3
- 20 to + 20 mA _____	.4
- 10 to + 10 V _____	.5

Analogue output 2	Code
Codes as for analogue output 1; not available in conjunction with Code 51/52	

Interface	Code
V.24 (RS232C) _____	51
RS422/485 _____	52

Self-optimisation	Code
(not on modulating controller) _____	53

Ramp function	Code
with external stop _____	54

Current input 0(4) - 20 mA	Code
via external shunt _____	60

1 DESCRIPTION

1.2 Indications and controls

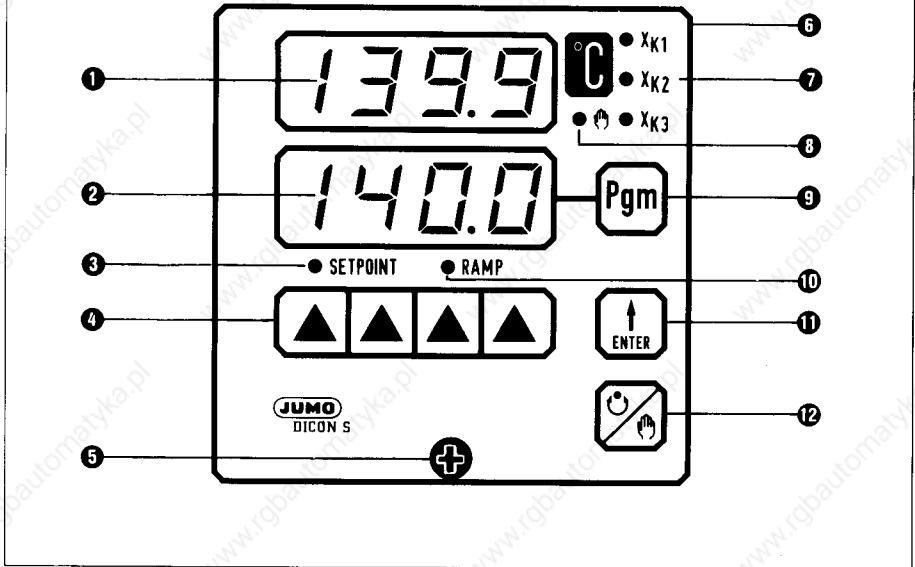

- 1 Numerical display**
4-digit LED display for actual value or other process variables
- 2 Alphanumeric display**
4-character text display for comments on numerical display or for indicating further process variables (can be configured by the keys)
- 3 LED for setpoint W**
(alight when the upper or lower display indicates the setpoint)
- 4 Increment keys**
with the 4 keys any position in the display can be changed immediately
- 5 Fixing screw for the controller chassis**
- 6 DIN housing for flush panel mounting**
bezel 96 x 96 mm
- 7 LEDs**
for on/off outputs
- 8 LED**
for manual operation
- 9 Programming key**
for parameter selection
- 10 LED ramp function**
- 11 Enter key**
for entering the inputs
- 12 Auto/manual key**

2 TECHNICAL DATA

Controller for use with resistance thermometers

Input

Pt 100, Pt 500 in 3-wire or 4-wire circuit

Range (°C or °F)

– 199.9 to + 850.0 °C

Line adjustment

not required with 3-wire or 4-wire circuit. When using an existing resistance thermometer in 2-wire circuit it is necessary to provide line adjustment. This can be done either in the configuration plane or by means of an external line adjustment resistor.

$$R_{\text{adjustment}} = R_{\text{line}}$$

Controller for use with thermocouples

Input

Cu-Con U, Fe-Con L, NiCr-Ni K, Pt10Rh-Pt S, Pt13Rh-Pt R, Pt30Rh-Pt6Rh B, MoRe5-MoRe41 according to IEC or ISA

Ranges (°C or °F)

Cu-Con U
– 200 + 600 °C

Fe-Con L
– 200 + 900 °C

Cu-Con T
– 200 + 400 °C

Fe-Con J
– 200 + 900 °C

NiCr-Ni K
– 200 + 1400 °C

Pt10Rh-Pt S
0 + 1800 °C

Pt13Rh-Pt R
0 + 1800 °C

Pt30Rh-Pt6Rh B
0 + 1820 °C

MoRe5-MoRe41
0 + 1990 °C

Isolation up to 5 V

Temperature compensation

internal; external available (can be configured)

Controller for use with linearised transducers with current or voltage signal

Input

0 – 1 mA

$R_i = 50 \Omega$

0(4) – 20 mA

$R_i = 2.5 \Omega$

0 – 50 mV

$R_i = 100 \text{ k}\Omega \text{ min.}$

0 – 1 V

$R_i = 50 \text{ k}\Omega$

0 – 10 V

$R_i = 500 \text{ k}\Omega$

Control and display range

freely configurable

Controller for use with non-linearised transducers with current or voltage signal

Input

as for linearised transducers with current or voltage signal

Ranges

signal/value relationship can be configured

Controller for use with resistance transmitters

Input

range: 0–30 Ω min., 0–10 k Ω max., adjusted with keys in the configuration plane, see Section 10.3

Ranges

determined in the configuration plane

Outputs

3 on/off and up to 2 fully isolated analogue outputs are available.

1. Relay outputs with floating contact
Rating: 660 W 3 A at 220 V 50 Hz, resistive load
Contact life: approx. 10^6 operations at rated load
2. Logic output
0/5 V or 0/20 mA, $R_i = 240 \Omega$
3. Semiconductor output
1 A at 220 V 50 Hz, p.f. 0.7 min.
4. Analogue output
as selected

burden
0 – 20 mA 500 Ω max.
4 – 20 mA 500 Ω max.
– 20/0/ + 20 mA 500 Ω max.
0 – 10 V 500 Ω min.
– 10/0/ + 10 V 500 Ω min.

Resolution of D/A converter

13 bit

Accuracy of output signal

0.25 % or better

General controller data

Controller type

can be used as single-setpoint or double-setpoint controller, modulating or proportional controller, with integral control station for bump-free auto-manual changeover

2 TECHNICAL DATA

A/D converter

resolution 14 bit

Controller accuracy

ambient
temperature error

when used with resistance thermometers and resistance transmitters:

0.05 % or better | 0.01% max. per 10 °C

when used with thermocouples within working range:

0.25 % or better | 0.05 % max. per 10 °C

when used with linearised transducers with current or voltage signal:

0.05 % or better | 0.05 % max. per 10 °C

These values include the linearisation tolerances.

Signal circuit monitor

(interruption or short-circuit of sensor)

1. Controller output

The output changes to a pre-defined value or the controller switches to manual operation.

2. Alarm relay

The alarm relay (I1k9 or I1k10) changes to a pre-defined status.

3. The limit comparators become inactive.

Data back-up

by lithium battery, Varta Type CR1/3N SLF, battery life 5 years min.; nominal voltage 3 V

Supply

normally 220 V, +10 %/–15 %, 40–60 Hz, can be re-soldered to

110 V, +10 %/–15 %, 40–60 Hz,

(see Section 9): other voltages to special order

Loading

15 VA approx.

Supply for 2-wire transmitter

20 V 40 mA, fully isolated

Electrical connection

through faston connectors to DIN 46 244/A, 4.8 x 0.8 mm

Permitted ambient temperature range

0 to +50 °C

Permitted storage temperature range

–40 to +70 °C

Climatic conditions

application Class KWF to DIN 40 040, relative humidity not exceeding 75 % annual mean, no condensation

Housing

aluminium extrusions, black anodised, with plug-in chassis (connected to ground)

Protection

to DIN 40 050

front IP 54

rear IP 20

Operating position

unrestricted

Interfaces

V.24 (RS232C) or RS422/485

(fully isolated). Data format, baud rate and device addresses (for 422/485) can be configured.

Operating mode: communication mode

2 TECHNICAL DATA

Limit comparator

The controller is provided with up to 3 limit comparators. The desired limit comparator function, the setpoint and the switching differential are adjustable in the configuration plane.

Functions Ik1–Ik8

1 Limit comparator Ik1

Relay is energised when the process is within the set window, de-energised when the process is outside the window.

2 Ik2 as Ik1

but relay action reversed

3 Ik3, low alarm only

Relay is de-energised when process is below alarm setting.

4 Ik4 as Ik3

but relay action reversed

5 Ik5, high alarm only

Relay is de-energised when process is above alarm setting.

6 Ik6 as Ik5

but relay action reversed

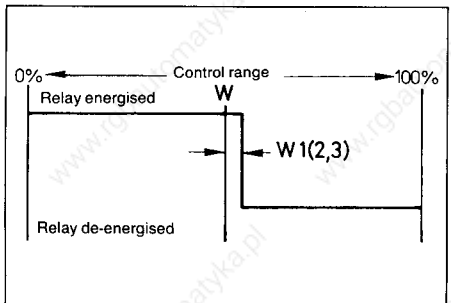
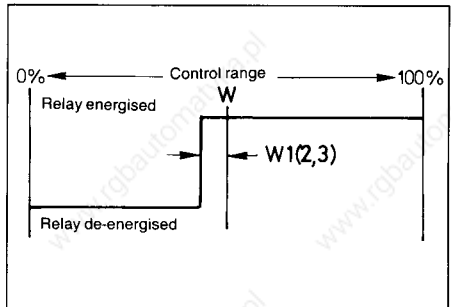
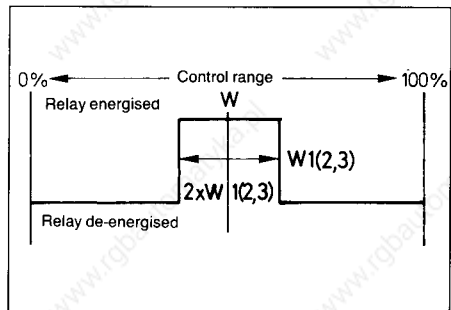

2 TECHNICAL DATA

7 Ik7, adjustable over full control span

Relay is energised when process is above alarm setting

8 Ik8 as Ik7

but relay action reversed

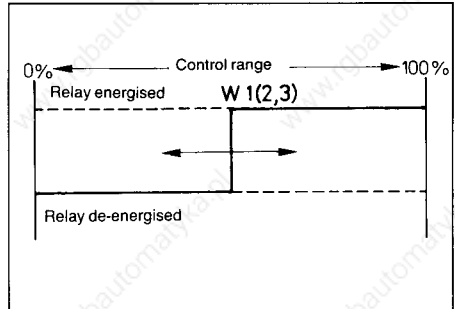

Alarm functions (relay Xk3)

9 Ik9, adjustable over full control span

Relay is energised when heater current falls below setting, also on failure or short-circuit of sensor.

10 Ik10 as Ik9

but relay action reversed

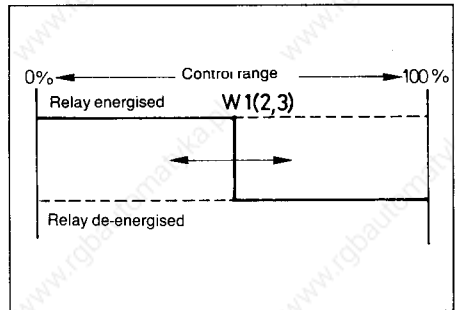

3 INSTALLATION

3.1 Location and climatic conditions

The instrument location should as far as possible be free from vibrations. Stray electromagnetic fields, e.g. from motors, transformers etc., should be avoided. The ambient temperature at the instrument location should be between 0 and 50 °C at a relative humidity not exceeding 75%. Corrosive conditions or fumes reduce the life of the instrument.

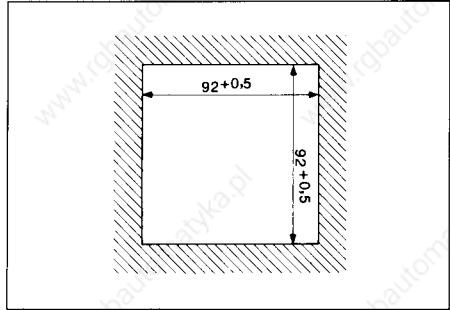

3.2 Fitting in position

Insert the controller from the front into the panel cut-out. From the back of the panel insert the two mounting brackets into the cut-outs in the sides of the housing. The flat bracket faces must lie against the housing. The brackets are then placed against the rear of the panel and tightened up evenly with a screwdriver.

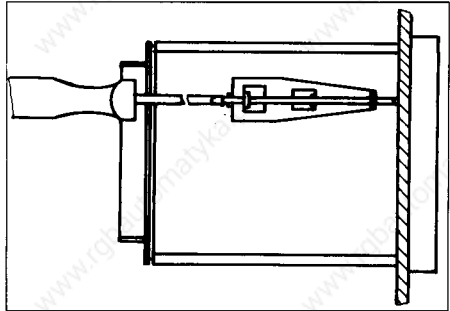

3.3 Dimensions

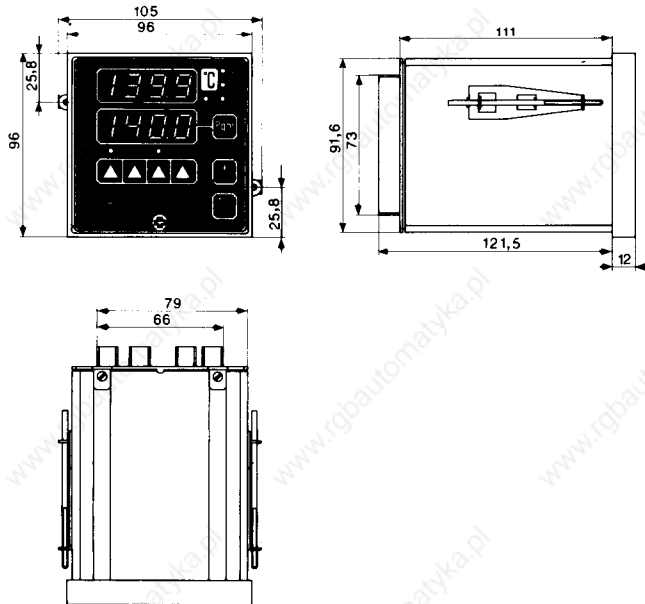

4 ELECTRICAL CONNECTION

The electrical connections are made in accordance with the connection diagram below. The choice of cable and the installation of the supply line must meet the requirements of VDE 0100 "Regulations on the Installation of Power Circuits with nominal voltages below 1000 V" or the appropriate local regulations.

Right-hand illustration:
Rear view with faston connectors

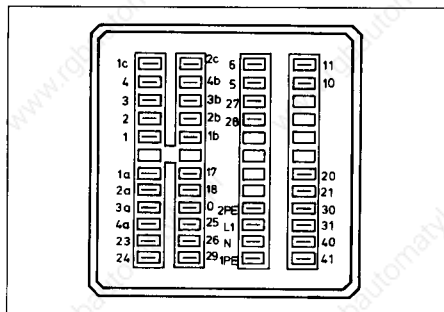

4.1 Connection diagram

Connection for		Terminals				
Analogue output 1		5 + 6 -				
Analogue output 2		27 + 28 -				
			Relay output	Semiconductor relay output	Logic control output i20/u5	
Relay or semiconductor relay or logic outputs	1 Xk1	20 (P) pole 21 (S) closing		20 21	20 + 21 -	
	2 Xk2	30 (P) pole 31 (S) closing		30 31	30 + 31 -	
	3 Xk3	40 (P) pole 41 (S) closing		40 41	40 + 41 -	
Supply for 2-wire transmitter		11 + 10 -	20 V 40 mA			
Supply see label		L1 line N neutral 1 PE ground 2 PE connection for screen				
Serial interface RS232C (V.24)	RxD	23		Received data		
	TxD	25		Transmitted data		
	CTS	24		Clear to send		
	RTS	26		Request to send		
	GND	29		Signal ground		
Serial interface RS422	A (+) B (-)	23 24		Received data (receiving pair)		
	A (+) B (-)	25 26		Transmitted data (transmitting pair)		
	GND	29		Signal ground		
Serial interface RS485	A (+) B (-)	25 26		Transmitted/Received data (transmitting/receiving pair)		
	GND	29		Signal ground		

* contact protection circuit 56 Ω, 22 nF

4 ELECTRICAL CONNECTION

Inputs

The DICON S has 4 analogue inputs and a total of 5 standard models determined by the hardware, each of which is represented by a **single line**.

For functions of the signal inputs see rating label and description on page 3.

Process 1	Input 2	Input 3	Input 4	Model
resistance thermometer/ thermocouple/ current/voltage ¹⁾	resistance thermometer/ thermocouple/ current/voltage ¹⁾	resistance transmitter	current/voltage	1
current/voltage	current/voltage	resistance transmitter	current/voltage	2
resistance thermometer/ thermocouple/ current/voltage ¹⁾	current 0–20 mA a.c.	resistance transmitter	current/voltage	3
current/voltage	current 0–20 mA a.c.	resistance transmitter	current/voltage	4
resistance transmitter	not used	resistance transmitter	current/voltage	5
to customer specification				



¹⁾ 0/4–20 mA, via external shunt (Code 60)

Input	Terminals					
Thermocouple	t	Input		– +		
		1 4	2 4a			3
Resistance thermometer in 3-wire circuit	w	1 2 3	1a 2a 3a			
Resistance thermometer in 4-wire circuit	w...vl	1 2 3 4	1a 2a 3a 4a			
Current 0/4–20 mA	e	1 2	1a 2a	– with external shunt, Code 60 +		
Current/voltage	e	1 2	1a 2a	1c 2c	– +	
Resistance transmitter with 3-wire connection	w...wfg	1 2 3	1a 2a 3a	1b 2b 3b	S = Slider E = end A = start	
External contact 1		17 0	+ GND			
External contact 2		18 0	+ GND			

4 ELECTRICAL CONNECTION

4.2 Important notes on installation

- All sensor and signal lines should where possible be run separately from the control and supply cables.
- Where several electronic units are installed it is preferable for each to have a separate supply cable including ground.
- Screened cables should be used; they should only be grounded at one end at the controller (terminal 2PE or ground terminals of housing on the back panel).
- Where possible provide physical separation between electronic units and contactors.
- If there are inductive loads close to the unit, such as contactors, solenoid valves etc., it is advisable to reduce interference by fitting an RC module to the contactor coil.
- No control circuit (relay, contactor) should be connected to the supply terminals of the instrument.
- Please observe the appropriate safety regulations for overtemperature monitoring.
- When using several inputs the probes or transducers must be connected together at a single point. On the DICON S the inputs for current, voltage and thermocouple are decoupled from each other (5 V max.) between the terminals 1, 1a, 1b, 1c. The resistance and resistance transmitter inputs are connected together and to the other inputs. When connecting up several sensors the following example should be noted:

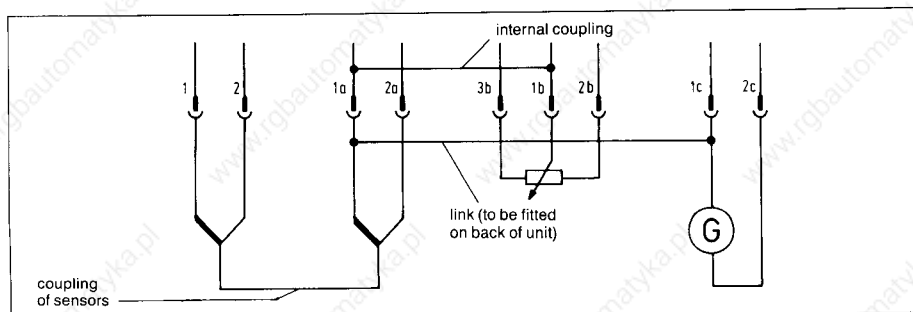

5 OPERATION

5.1 Planes and blockages

For clearer identification of the large number of possible programming inputs the controller data are arranged in three distinct planes: operating plane, parameter plane and configuration plane.

Operating plane/standard display

The two displays show setpoint and actual value. The setpoint can be changed. It is also possible to change over to manual operation. With appropriate configuration (see Section 7.3) it is possible to produce other displays, such as heater current, stroke, second process variable, reference temperature.

Parameter plane

In this plane the controller can be matched to the process. The individual parameters are displayed sequentially as value and symbol. Only those parameters are indicated which correspond to the particular controller model (see Section 6).

Configuration plane

This plane serves to adapt the controller to the particular application. The control is out of action. It is seldom necessary to change the factory settings, e.g. when the control application or the input circuit is altered (see Section 7).

In addition it offers a choice whether the controller on switching on operates with the factory settings in the configuration plane or whether the data entered by the user are used (see Section 9).

The three planes can be blocked with internal switches (see Section 9).

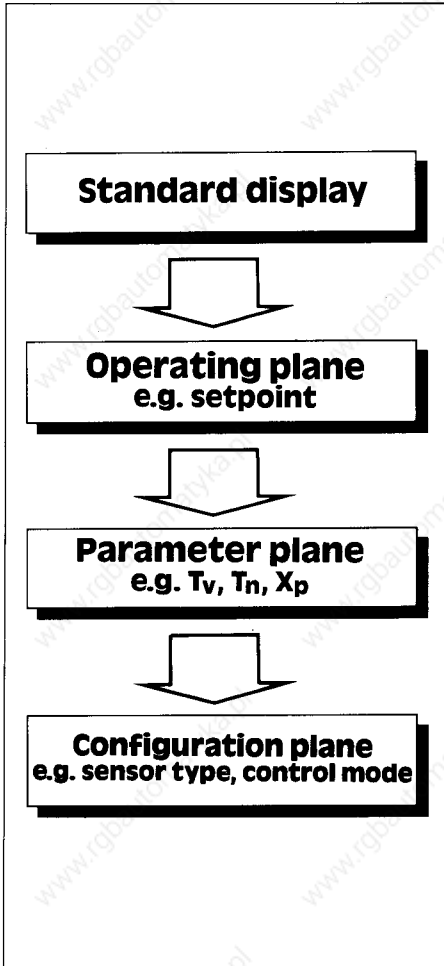

Plane	Blockage	Controller data
Operating plane	Access possible	Adjustment by user
Parameter plane	Access possible	Set at the factory; user adjustment possible
Configuration plane	Blocked at the factory	Set at the factory; user adjustment possible

5 OPERATION

5.2 Displays

The process variable is shown on the upper display and the setpoint on the lower display. For different displays see ordering details or configuration data (see Section 7.3). These parameters are called up with the "Pgm" key.

5.3 Displaying process and setpoint and changing setpoint

In the standard arrangement the process is shown in the upper display and the setpoint in the bottom display. After pressing the "Pgm" key the top display shows the setpoint and the bottom display the parameter name W. Change the setpoint with the 4 increment keys: After an increment key has been operated the parameter name W flashes. Enter the changed setpoint with the "ENTER" key. Further parameters can be displayed by pressing the "Pgm" key or the controller returns to the standard display¹⁾.

If there is no input for 30 seconds the controller returns automatically to the standard display (time-out).

Changing the time-out see Section 7 (Code C183).

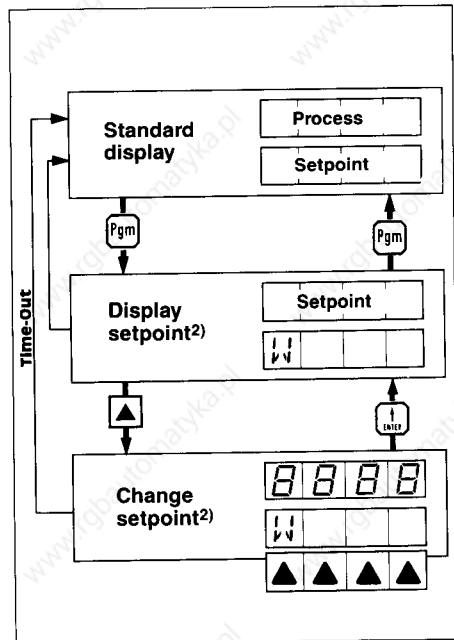

¹⁾ Further parameters are contained in the sub-directory UV08 of the configuration table (Section 7.3); these can be entered into the operating plane.

²⁾ 1 or 3 additional setpoints can be entered in the configuration plane Code C151.

5 OPERATION

5.4 Manual operation

The controller is supplied with the manual operation blocked. This operating mode becomes accessible with the internal switch S 301.3 (see Section 9).

Note:

Manual operation is not possible with Xp1 or Xp2 = 0.

Modulating controller

The control loop is opened by operating the "auto/manual" key. The two displays show the process and the actual stroke. The stroke is changed with the left and right increment keys within the range 0–100%. The actuator opens or closes continuously while the key remains depressed. After operating the "auto/manual" key the controller returns to the standard display and is again on automatic operation.

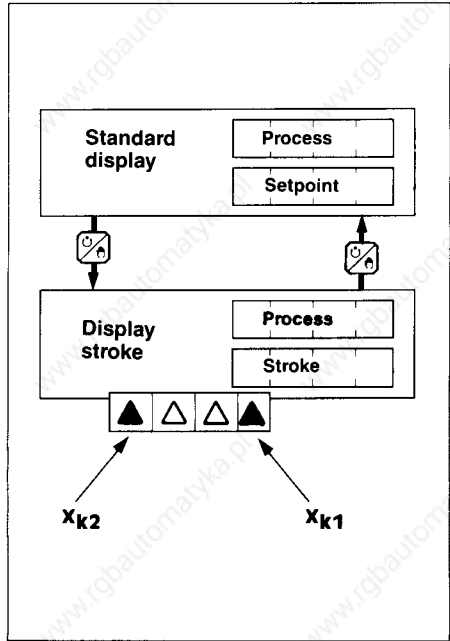

Single-setpoint, double-setpoint and proportional controller

The control loop is opened by operating the "auto-manual" key. The two displays show the process and the actual stroke. After "Pgm" the stroke is shown in the top display, the bottom display shows the parameter name Yh. The stroke can be changed with the increment keys within the range 0–100% (–100/0/+100% on the double-setpoint controller). After operating the "auto/manual" key the controller returns to the standard display and is again on automatic operation.

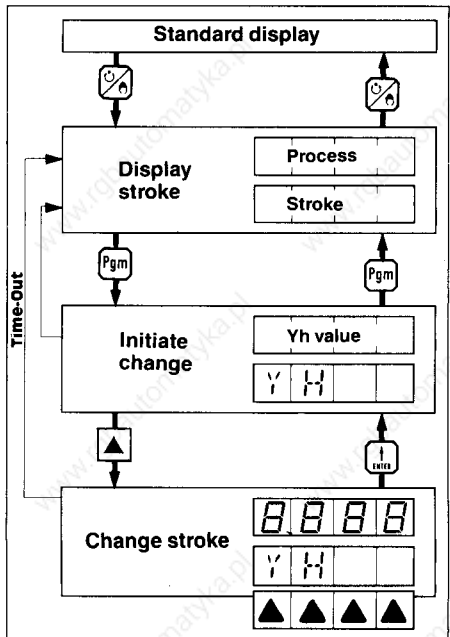

6 PARAMETER PLANE

Access to the parameter plane is obtained by pressing the key (*) for 5 seconds. The key is located at the bottom on the left-hand side of the controller front panel (not visible).

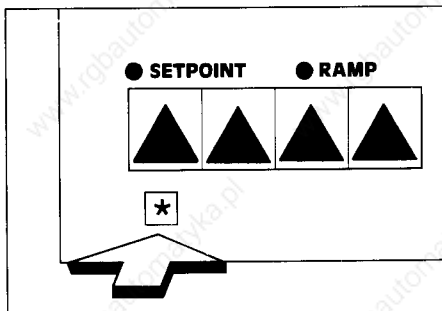

6.1 Displaying and changing parameters

The parameters are called up in sequence with the "Pgm" key. The parameters of the individual controller versions are listed in the Table alongside.

After the last parameter the controller automatically returns to the standard display. When one of the increment keys is pressed for changing the parameter, the parameter name (e.g. T_v , T_n) flashes in the bottom display. After the changed value has been entered with "ENTER", further parameters are displayed with "Pgm".

In case of inappropriate inputs the top display shows the minimum or maximum value permitted.

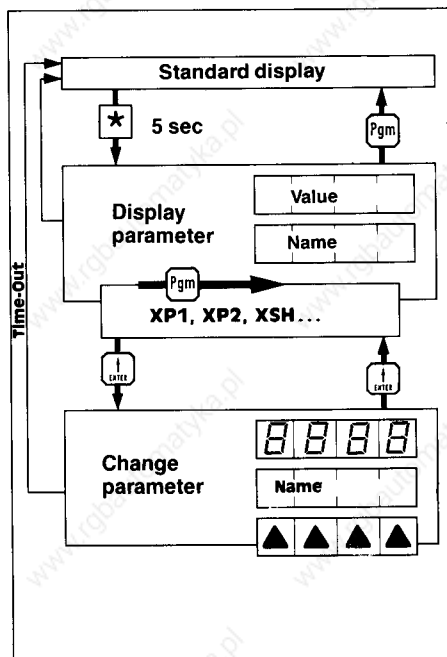

6 PARAMETER PLANE

6.2 Parameter table

Single-setpoint controller with two limit comparators

Symbol	Parameter	none ¹⁾	Feedback action			Adjustment range	Factory setting
			PD	PID	PD/PID		
XP	Proportional band	—	■	■	■	Xp = 0 – 9999 digit	0 digit
XD	Differential	■	—	—	—	Xd = 1 – 9999 digit	1.0 digit
TV	Derivative time	—	■	—*	■	Tv = 1 – 999 sec	80 sec
TN	Reset time	—	—	—	■	Tn = 1 – 9999 sec	350 sec
CY	Cycle time	—	■	■	■	Cy = 0.1 – 99.9 sec	20.0 sec
Y1	Max. valve stroke	—	■	■	■	Y1 = 0 – 100 %	100 %
RAMP ²⁾	Ramp slope	■	■	■	■	RAMP = $\frac{0.0 - 999.9 \text{ digit}}{\text{min(h)}}$	0.0 digit min(h) ³⁾

Double-setpoint controller with one limit comparator

Symbol	Parameter	none ¹⁾	Feedback action			Adjustment range	Factory setting
			PD	PID	PD/PID		
XP1	Proportional band (heating contact)	—	■	■	■	Xp1 = 0 – 9999 digit	0 digit
XP2	Proportional band (cooling contact)	—	■	■	■	Xp2 = 0 – 9999 digit	0 digit
XSH	Contact spacing	■	■	■	■	XSh = 0 – 999.9 digit	0 digit
XD1	Differential (heating contact)	■	—	—	—	Xd1 = 0 – 999.9 digit	1.0 digit
XD2	Differential (cooling contact)	■	—	—	—	Xd2 = 0 – 999.9 digit	1.0 digit
TV	Derivative time	—	■	—*	■	Tv = 1 – 999 sec	80 sec
TN	Reset time	—	—	—	■	Tn = 1 – 9999 sec	350 sec
CY1	Cycle time	—	■	■	■	Cy1 = 0.1 – 100.0 sec	20.0 sec
CY2	Cycle time	—	■	■	■	Cy2 = 0.1 – 100.0 sec	20.0 sec
Y1	Max. valve stroke	—	■	■	■	Y1 = 0 – 100 %	100 %
Y2	Min. valve stroke	—	■	■	■	Y2 = 0 to – 100 %	– 100 %
RAMP ²⁾	Ramp slope	■	■	■	■	RAMP = $\frac{0.0 - 999.9 \text{ digit}}{\text{min(h)}}$	0.0 digit min(h) ³⁾

Modulating controller with one limit comparator

Symbol	Parameter	none ¹⁾	Feedback action			Adjustment range	Factory setting
			PI	PID	—		
XP1	Proportional band	—	■	■	—	Xp1 = 0 – 9999 digit	0 digit
XSH	Contact spacing	■	■	■	—	XSh = 0 – 999.9 digit	0 digit
XD1	Differential	■	—	—	—	Xd1 = 1 – 999.9 digit	1.0 digit
TN	Reset time	—	■	■*	—	Tn = 1 – 9999 sec	350 sec
RAMP ²⁾	Ramp slope	■	■	■	—	RAMP = $\frac{0.0 - 999.9 \text{ digit}}{\text{min(h)}}$	0.0 digit min(h) ³⁾

Proportional controller with three limit comparators

Symbol	Parameter	P	Feedback action			Adjustment range	Factory setting
			PI	PD	PID		
XP1	Proportional band	■	—	■	■	Xp1 = 0 – 9999 digit	100 digit
TV	Derivative time	—	■	■	■	Tv = 1 – 999 sec	80 sec
TN	Reset time	—	■	—	■	Tn = 1 – 9999 sec	350 sec
Y1	Max. valve stroke	■	—	■	■	Y1 = 0 – 100 %	100 %
Y2	Operating point	■	—	■	—	Y2 = 0 – 100 %	50 %
RAMP ²⁾	Ramp slope	■	■	■	■	RAMP = $\frac{0.0 - 999.9 \text{ digit}}{\text{min(h)}}$	0.0 digit min(h) ³⁾

■ adjustable

□ factory setting

* Tv = Tn/4.5

¹⁾Xp = 0 means feedback stopped

²⁾option

³⁾0.0 means "ramp function stopped", min/h can be configured in UV05, Code C151

7 CONFIGURATION PLANE

7.1 Displaying configuration data

The configuration plane can only be accessed from the parameter plane.

The configuration data are divided into nine sub-directories UV01–09.

The step „Turn pages of sub-directory“ permits rapid location of the configuration code.

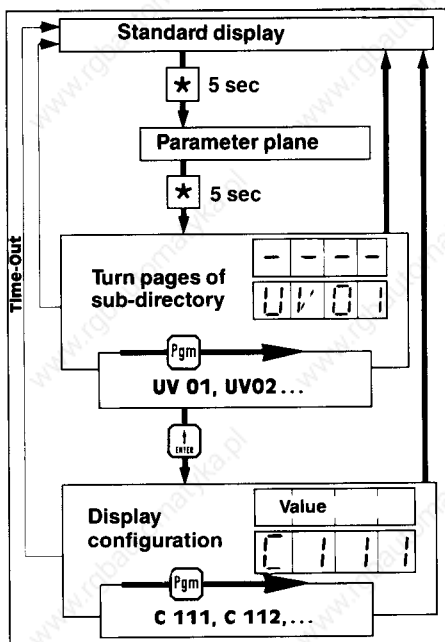

Example:

Which value is shown in the alphanumeric display; Code 181?

Turn pages up to sub-directory UV08, after pressing “ENTER” the display is as shown alongside. As seen from the configuration table, the number 1 in the top display represents the setpoint display.

After pressing “Pgm” all the codes of the sub-directory UV08 appear in sequence; this is followed by the pages of the subsequent sub-directory being turned over.

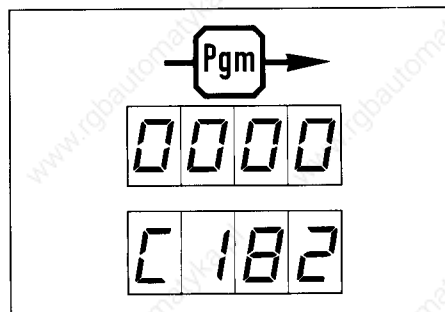
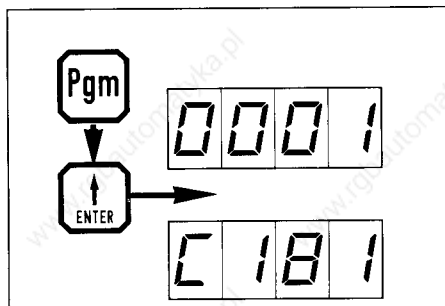

7 CONFIGURATION PLANE

7.2 Changing configuration data

Access to the configuration plane is only possible after the plane has been unblocked and the data transfer of the factory-set parameters has been switched off (see Section 9).

Many changes in configuration data also require adjustment of other parameters. If, for example, the control action is changed from double-setpoint controller to single-setpoint controller, feedback action, proportional band etc. must also be set again. If a parameter has been omitted this would result in an undesirable or faulty control action.

The controller is therefore provided with operator guidance which only permits return to the operating plane or standard display after all the necessary changes have been made completely and logically.

Following an incorrect input the top display flashes and requests correction of the input.

Every unintentional change of a configuration parameter can result in a change to other parameters.

The status as supplied from the factory can always be restored by reading in the factory-set parameters.

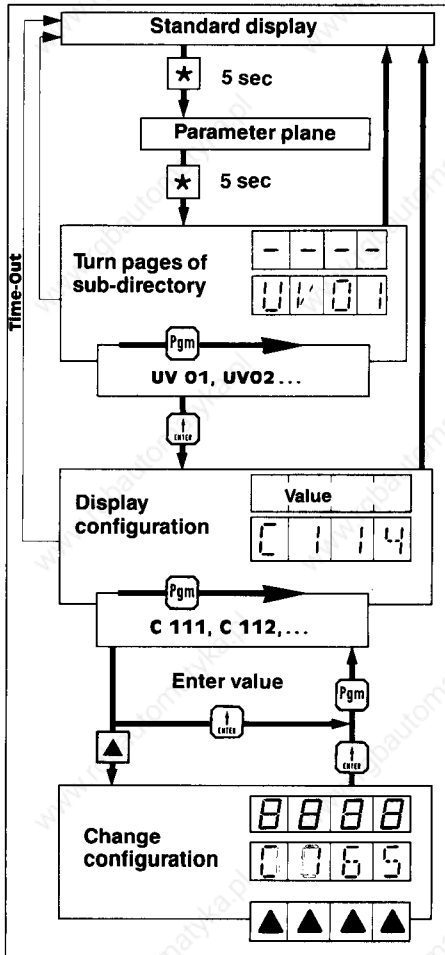

Call-up configuration parameter, change it if required and confirm the input with "ENTER".



After pressing "Pgm" the next parameter to be changed is displayed. Flashing of both displays indicates that operator guidance is activated.

The value shown in the top display is either entered with "ENTER" or a new value is input.

When all the necessary parameters have been changed or acknowledged the controller returns to the standard display.

7 CONFIGURATION PLANE

7.3 Configuration Table

UV01	Inputs		Input			
			1	2	3	4
C 111	Function Example: Channel 1: process Channel 2: 2nd process variable Channel 3, 4: off  Function depends on the input board fitted	no function _____	0	0	0	0
		process _____	1	1		
		reference temperature with				
		temperature difference measurement _____	2	2		
		display of a second process variable _____	3	3		
		stroke retransmission _____	4		4	
		external setpoint _____	5			5
		external reference temperature (Pt 100) _____	6	6		
		heater current indication _____	7	7		
		reference temperature for humidity _____	8	8		
		reference value for ratio _____	9	9		
external disturbance _____	A			A		
C 112	Transducer Example: Channel 1: Pt 100 Channel 2: Pt 100 Channel 3, 4: off 	channel off _____	0	0	0	0
		resistance thermometer				
		Pt 100 (500) ¹⁾ _____	1	1	1	
		thermocouple (internal or external reference				
		temperature) _____	2	2	2	
		thermocouple (fixed				
		external reference temperature) _____	3	3	3	
		resistance transmitter				
with 3-wire connection _____	4	4	4	4		
current 0 – 20 mA or						
voltage 0 – 10 V ¹⁾ _____	5	5	5	5		
current 4 – 20 mA _____	6	6	6	6		
heater current indication _____	7	7				
	¹⁾ if provided in hardware					

On inputs 1 and 2:						
C 113	Linearisation	linear	- 1999 to +9999 digit _____	0		0
		Pt 100(500) ¹⁾	- 199.9 + 850.0 °C _____	1		1
		Fe-Con L	- 200 + 900 °C _____	2		2
		NiCr-Ni K	- 200 + 1400 °C _____	3		3
		Pt10Rh-Pt S	0 + 1800 °C _____	4		4
		Pt13Rh-Pt R	0 + 1800 °C _____	5		5
		Pt30Rh-Pt6Rh B	0 + 1820 °C _____	6		6
		Cu-Con U	- 200 + 600 °C _____	7		7
		MoRe5-MoRe41	0 + 1990 °C _____	8		8
		Cu-Con T	- 200 + 400 °C _____	9		9
		Fe-Con J	- 200 + 900 °C _____	10		0
	¹⁾ if provided in hardware					
C 114	Selection °C/°F	temperature °C _____	0	0	0	0
		temperature °F _____	0	0	0	1
C 115	Decimal place	no decimal place _____	0	0	0	0
		one decimal place _____	0	0	0	1
		two decimal places ¹⁾ _____	0	0	0	2
		three decimal places ¹⁾ _____	0	0	0	3
	¹⁾ only possible with C113 = 0					

7 CONFIGURATION PLANE

UV02 Scale with resistance transmitter and current input			▲	▲	▲	▲
C 121	External reference temperature (see C 112)	range 0 + 100 °C standard setting: 50 °C	x	x	x	x
C 122	Minimum setpoint	range to DIN IEC	x	x	x	x
C 123	Maximum setpoint	range to DIN IEC	x	x	x	x
C 124¹⁾	Start of range process	0.0	x	x	x	x
C 125¹⁾	End of range process	100.0	x	x	x	x
C 126¹⁾	Start of range input 2	0.0	x	x	x	x
C 127¹⁾	End of range input 2	100.0	x	x	x	x
C 128¹⁾	Start of range input 3	0.0	x	x	x	x
C 129¹⁾	End of range input 3	100.0	x	x	x	x
C 12A¹⁾	Start of range input 4	0.0	x	x	x	x
C 12B¹⁾	End of range input 4	100.0	x	x	x	x

¹⁾ only with current, voltage and resistance transmitter inputs
Standard setting: start of range 0 digit, end of range 100 digit. Other ranges can be selected.

UV03 Process value correction and adjustment of start and end of resistance transmitter for stroke retransmission or current or voltage input (C 131 – C 134) with Code 60			▲	▲	▲	▲
C 131	Special user correction to Section 10.2 (factory-set to 0)	X0 input 1	x	x	x	x
C 132		X1 input 1	x	x	x	x
C 133		X0 input 2	x	x	x	x
C 134		X1 input 2	x	x	x	x
C 135		X0 input 3	x	x	x	x
C 136		X1 input 3	x	x	x	x
C 137		X0 input 4	x	x	x	x
C 138		X1 input 4	x	x	x	x

x = input within range

7 CONFIGURATION PLANE

Measured values for programmed indication			▲	▲	▲	▲
C 139	Not programmable, values are only displayed (see Section 10.2)	X0' input 1 0	x	x	x	x
C 13A		X1' input 1 100	x	x	x	x
C 13B		X0' input 2 0	x	x	x	x
C 13C		X1' input 2 100	x	x	x	x
C 13D		X0' input 3 0	x	x	x	x
C 13E		X1' input 3 100	x	x	x	x
C 13F		X0' input 4 0	x	x	x	x
C 13G		X1' input 4 100	x	x	x	x

7 CONFIGURATION PLANE

UV04 Analogue outputs		▲	▲	▲	▲	
C 141	Function output 1	no function _____	0	0	0	0
		process x _____	0	0	0	1
		setpoint w _____	0	0	0	2
		control deviation xw _____	0	0	0	3
		second process variable _____	0	0	0	4
		controller output Y _____	0	0	0	5
C 142 ¹⁾	Calibration output 1	value at 0% output signal (signal start) _____ standard setting: 0%	x	x	x	x
		value at 100% output signal (signal end) _____ standard setting: 100%	x	x	x	x
C 144	Signal output 1 ²⁾	0 – 20 mA ²⁾ _____	0	0	0	0
		4 – 20 mA ²⁾ _____	0	0	0	1
C 145	Function output 2	no function _____	0	0	0	0
		process x _____	0	0	0	1
		setpoint w _____	0	0	0	2
		control deviation xw _____	0	0	0	3
		second process variable _____	0	0	0	4
		controller output Y _____	0	0	0	5
C 146	Calibration output 2	value at 0% output signal (signal start) _____ standard setting: 0%	x	x	x	x
		value at 100% output signal (signal end) _____ standard setting: 100%	x	x	x	x
C 147						
C 148	Signal output 2 ²⁾	0 – 20 mA _____	0	0	0	0
		4 – 20 mA _____	1	0	0	1

¹⁾ not on proportional controller

²⁾ only if provided in hardware, see Section 9

UV05 Controller setting						
C 151	Controller and ramp function	controller _____	0	0		0
		controller with changeover from internal setpoint to external setpoint selection _____	0	0		1
		controller with external setpoint selection and correction _____	0	0		2
		controller with 1 extra internal setpoint _____	0	0		3
		controller with 3 additional internal setpoints _____	0	0		4
		no ramp function _____	0	0	0	
C 152	Controller type	ramp function _____	0	0	1	
		with gradient min _____	0	0		2
		with gradient h _____	0	0		
		proportional controller with falling characteristic ³⁾ _____	0	0	0	0
proportional controller with rising characteristic ³⁾ _____	0	0	0	1		
single-setpoint controller with max. contact (relay de-energised for process above setpoint) _____	0	0	0	2		
single-setpoint controller with min. contact (relay de-energised for process below setpoint) _____	0	0	0	3		
double-setpoint controller _____	0	0	0	4		
modulating controller _____	0	0	0	5		
³⁾ first select controller output Y (C 141 or C 145)						
C 153	Stroke period (on modulating controller)	range: 15 – 600 sec standard setting: 60 sec _____	x	x	x	x
C 154	Feedback action ²⁾	P _____	0	0	0	0
		PI _____	0	0	0	1
		PD _____	0	0	0	2
		PID _____	0	0	0	3
		PD/PID _____	0	0	0	4
²⁾ The feedback action is only effective for proportional band Xp ≠ 0						

x = input within range

7 CONFIGURATION PLANE

UV06 Limit comparators			▲	▲	▲	▲
C 161	Limit comparator relay 1 ¹⁾	no function _____	0	0	0	0
		function lk1 _____	0	0	0	1
		function lk2 _____	0	0	0	2
		function lk3 _____	0	0	0	3
		function lk4 _____	0	0	0	4
		function lk5 _____	0	0	0	5
		function lk6 _____	0	0	0	6
		function lk7 _____	0	0	0	7
		function lk8 _____	0	0	0	8
C 162	Switching differential relay 1	range: 1 – 9999 digit standard setting: 1 digit _____	x	x	x	x
C 163	Value relay 1	range: ± 9999 digit _____	x	x	x	x
C 164	Limit comparator relay 2 ¹⁾	no function _____	0	0	0	0
		function lk1 _____	0	0	0	1
		function lk2 _____	0	0	0	2
		function lk3 _____	0	0	0	3
		function lk4 _____	0	0	0	4
		function lk5 _____	0	0	0	5
		function lk6 _____	0	0	0	6
		function lk7 _____	0	0	0	7
		function lk8 _____	0	0	0	8
C 165	Switching differential relay 2	range: 1 – 9999 digit standard setting: 1 digit _____	x	x	x	x
C 166	Value relay 2	range: ± 9999 digit _____	x	x	x	x
C 167	Limit comparator relay 3 ¹⁾	no function _____	0	0	0	0
		function lk1 _____	0	0	0	1
		function lk2 _____	0	0	0	2
		function lk3 _____	0	0	0	3
		function lk4 _____	0	0	0	4
		function lk5 _____	0	0	0	5
		function lk6 _____	0	0	0	6
		function lk7 _____	0	0	0	7
		function lk8 _____	0	0	0	8
		function lk9 _____	0	0	0	9
		function lk10 _____	0	0	0	A
C 168	Switching differential relay 3	range: 1 – 9999 digit standard setting: 1 digit _____	x	x	x	x
C 169	Value relay 3	range: ± 9999 digit _____	x	x	x	x

¹⁾ The relays are available as control contacts or limit comparators depending on the controller type.

x = input within range

7 CONFIGURATION PLANE

UV07 Interface			▲	▲	▲	▲	
C 171	Instrument address	range: 0 – 31 _____	x	x	x	x	
C 172	Data format	parity bit	no parity _____				0
			parity odd _____				1
			parity even _____				2
		1 stop bit _____				1	
		2 stop bits _____				2	
		7 data bits _____		7			
		8 data bits _____		8			
		baud rate	9600 _____	0			
			4800 _____	1			
			2400 _____	2			
			1200 _____	3			
			600 _____	4			
			300 _____	5			
			150 _____	6			
C 173	Special functions	terminal mode	OFF _____	0	0		0
			ON _____	0	0		1
		end character	CR _____	0	0	0	
			CR/LF _____	0	0	1	

UV08 Display			▲	▲	▲	▲
C 181	Alphanumerical display on standard display	no display _____	0	0		0
		setpoint _____	0	0		1
		controller output signal Y _____	0	0		2
		master value _____	0	0		3
		heater current indication 0 – 100 % _____	0	0		4
		second process variable _____	0	0		5
		parameter name _____	0	0		6
		deviation indication (trend) _____	0	0		7
		parameter name and deviation indication _____	0	0		8
			Numerical display	process _____	0	0
		deviation indication _____	0	0	1	
		slave value with td, ps, c ¹⁾ _____	0	0	2	
C 182	Parameters in the operating plane	external disturbance _____	0			1
		controller output signal Y _____	0		1	
		second process variable _____	0	1		
C 183	Hold time (time-out)	range: 0 – 225 sec _____	x	x	x	x
		standard setting: 30 sec				

¹⁾ td = temperature difference input, ps = psychrometric humidity input, c = ratio input

x = input within the value range

7 CONFIGURATION PLANE

UV09 Special functions			▲	▲	▲	▲
C 191	Controller output signal on overrange or underrange ¹⁾	0 to 100 % or – 100 to + 100 % _____ With an input of 101 the controller signal current before the error continues to be output	x	x	x	x
	On modulating controller	100 output relay Xk1 energised 0 output relay Xk2 energised 101 output relays Xk1 and Xk2 de-energised				
C 192	Time constant of relay 1 ²⁾	range: 0 – 60 sec _____ standard setting: 0 sec			x	x
C 193	Time constant of relay 2 ²⁾	range: 0 – 60 sec _____ standard setting: 0 sec			x	x
C 194	Functions of external contacts ³⁾	no function _____	0	0	K1 ⁴⁾	K2 ⁴⁾
		starting self-optimisation _____	0	0	0	0
		changeover auto/manual _____	0	0	1	1
		manual mode blocked _____	0	0	2	2
		keys blocked _____	0	0	3	3
		external stop of ramp function _____	0	0	4	4

¹⁾ On single-setpoint and double-setpoint controller and proportional controller

²⁾ Min. switch-on time, e.g. for burner control

³⁾ If controller function 1 or 3 is configured in C 151, changeover takes place through external contact 1. If C 151 is configured as controller function 4, change-over takes place through contacts 1 or 2.

⁴⁾ Both contacts with the same function not permitted!

x = input within the value range.

8 ACTION ON FAULTS

8.1 Error messages

Er 10:

The voltage of the built-in lithium battery is insufficient to protect the data in case of supply failure.

Remedy:

The error message can be cancelled with any key. Arrange for the battery to be changed within 4 weeks.

Er 11:

Despite a fault in the processor sequence the "watchdog" (internal monitoring circuit) was not activated.

Remedy:

Cancel the error message by switching the supply off and on again. Return the controller for checking as soon as possible.

Er 20:

The data in the working memory are partially erased.

Remedy:

Read-in the factory-set data from the EPROM, i.e. switch off supply voltage; set internal switches S 301.5 to position \uparrow and S 301.6 to position \downarrow and switch supply on again. The error message may appear again for about $\frac{1}{2}$ sec after switching on.

The controller reads in the data set at the factory.

Er 21:

After a RAM fault and after replacing the EPROM the controller is initialised automatically. This error message then follows.

Remedy:

The error message can be cancelled by pressing any key.

Er 30:

Incorrect process correction through input X0 = X1 or X1 = 0.

Remedy:

The error message can be cancelled by pressing any key.

The parameters X0 and X1 are automatically set to the standard setting, i.e. the incorrect input is ignored. If necessary repeat the process correction.

Er 40:

The process exceeds the display capacity.

Remedy:

Reduce the number of places after the decimal point or operate an increment key.

8.2 Action on supply failure

After supply failure the controller returns to the standard display. An exception is the configuration plane: after supply failure during a configuration procedure the controller returns to the last step performed.

The data are backed up by a lithium battery for more than 5 years.

8.3 Action on failure or short-circuit of sensor

See Technical Data, Section 2, or Configuration Table UV09, C191!

9 INTERNAL ADJUSTMENTS

Analogue output

The output signal is set on DIL switches. The changeover between 0–20 mA and 4–20 mA is made through the software and is described in Section 7.3 (Code C 144). The controller is supplied fully adjusted. If a different output signal is selected on the switches S1001.1–S1001.4 or S1201.1–S1201.4 a slight re-adjustment of the output signal with the potentiometers R1030 and R1230 or R1230 and R1231 is recommended.

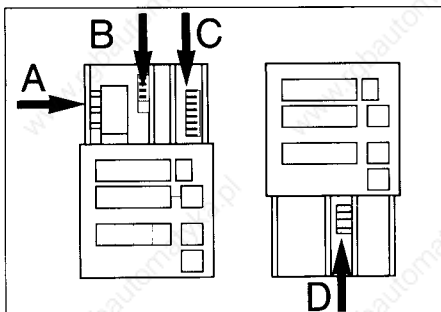

Analogue output 1

Output signal	S1201.1	S1201.2	S1201.3	S1201.4
0... 10 V	o	x	x	o
-10... +10 V	x	x	x	o
0(4)... 20 mA	o	o	o	x
-20... +20 mA	x	o	o	x

x = closed o = open

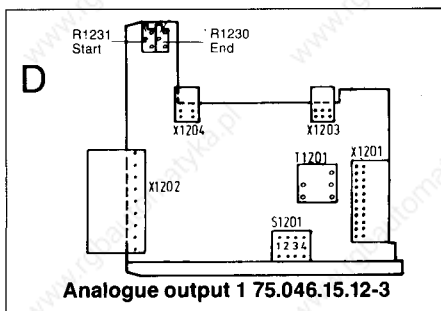

Analogue output 2

Code 30	S1001.1	S1001.2	S1001.3	S1001.4
0... 10 V	o	x	x	o
-10... +10 V	x	x	x	o
0(4)... 20 mA	o	o	o	x
-20... +20 mA	x	o	o	x

x = closed o = open

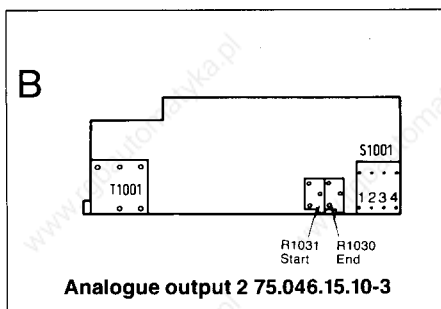

Voltage supply

Voltage	Solder links			
220 V	■	■	■	■
110 V	■	■	■	■

■: standard setting

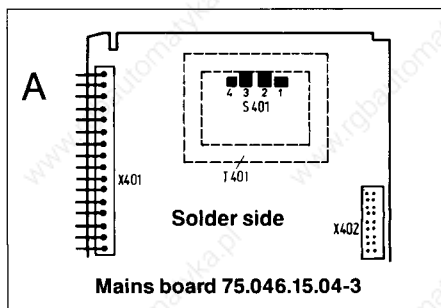

9 INTERNAL ADJUSTMENTS

Switch 7 is provided for service purposes only and is set to the top position at the factory. 

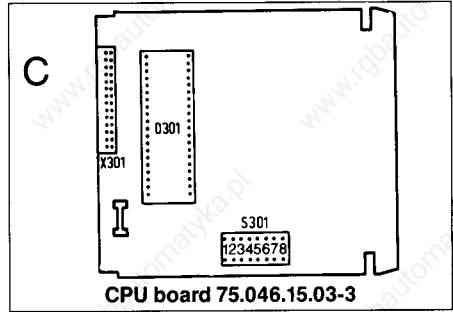









Plane blockage

All planes are blocked; no access to the parameter and configuration planes. Process variables of the configuration plane can be called up but cannot be changed.

No access to these planes.



No access to this plane.

All planes can be accessed.

Planes blocked	S 301	
	1	2
Operating plane (only call-up permitted) Parameter plane Configuration plane		
Parameter plane Configuration plane		
Configuration plane		
No blockage		

Self-optimisation

On fast control processes, better optimisation may be achieved by changing over switch S301.8.

Self-optimisation	S 301.	
	8	
slow process. Tg > 2 min		
fast process Tg < 2 min		

: factory setting

9 INTERNAL ADJUSTMENTS

Data acceptance

Configuration data and parameter data are read from the EPROM into the working memory (RAM) when S301.5 is ↑ and S301.6 is ↓.

This means the parameters of these two planes can be called up but cannot be changed.

In position S301.5 ↑ and S301.6 ↑ (factory setting) only the parameter data can be changed.

In position S301.5 ↓ the data transfer is switched off and the controller can be freely re-programmed.

With switch position S301.5 ↑ and S301.6 ↓ it is always possible to return to the base setting or setting as supplied from the factory.

Factory-set data	S301.5	S301.6
yes	↑	
no	↓	
Acceptance in		
Configuration plane		↑
Configuration and parameter plane		↓

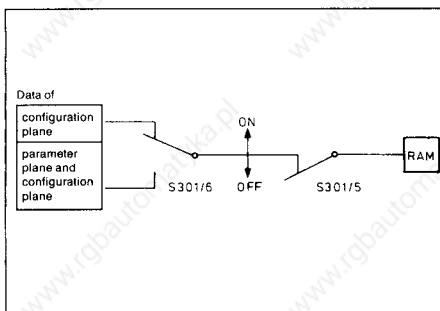

Manual operation

Manual operation is blocked at the factory. Switch S301.3 must be changed over when using the control station.

Manual operation	S301.3	
blocked	↑	
free	↓	

Input filter

Digital filter for smoothing the input signal; time constant 1 sec.

Input filter	S301.4	
on	↑	
off	↓	

▒ : standard setting

10 ADDITIONAL FUNCTIONS

10.1 Meaning of the external contacts

Selection of additional internal setpoints

Up to 4 internal setpoints can be used which can be selected by external floating contacts (configuration C151).

The additional setpoints are set in the operating plane (see Section 5.3); the current setpoint W is displayed on operating the Pgm key.

A total of 5 setpoints are thus displayed in the operating plane, of which W is always identical with one of the additional 4 setpoints.

Depending on the switch position (K1, K2) the current setpoint W is equal to W1, W2, W3 or W4.

Example:

If setpoint W is programmed in switch position K2 = 1, W equals W3.

	K1	K2
Setpoint 1:	0	0
Setpoint 2:	1	0
Setpoint 3:	0	1
Setpoint 4:	1	1

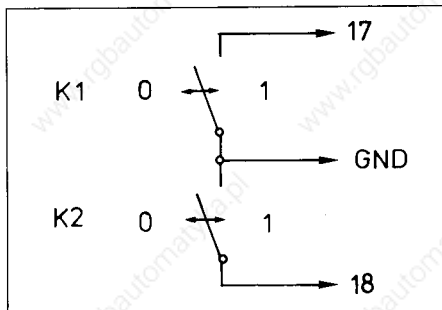

External setpoint selection

The external setpoint is set as proportional current 0(4)–20 mA or voltage 0–10 V (configuration C112). The changeover from internal to external setpoint is made with an external floating contact.

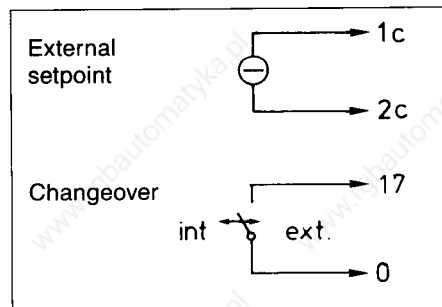

External setpoint selection with setpoint correction from the front (C151)

The actual external setpoint can be corrected with the keys.

Example: display 170.3, desired display 175.3

The setpoint displayed is overwritten with the desired setpoint using the increment keys. All external setpoints are then corrected automatically, in the example by +5 °C.

For further functions of the external contacts see Section 10.6!

10 ADDITIONAL FUNCTIONS

10.2 Correction of process indication to customer specification

A process indication differing from the desired or actual value can be corrected with the keys. This is useful, for example, in order to match the indication of several instruments or to compensate for the resistance of the sensor cable. Two values are input, the intermediate values are interpolated or extrapolated by the controller.

Example:

When the process value is 15 the process indication should be 40.

When the process value is 90 the process indication should be 60.

Programming:

With a process value of 15, 40 is programmed in parameter X0 (C131).

With a process value of 90, 60 is programmed in parameter X1 (C132).

Display of X0' (C139) = 15

Display of X1' (C13A) = 90

The corrections should be performed near the start of range and the end of range so that X0' and X1' are sufficiently far apart.

To restore the base setting X0 must equal X1. First X1 and then X0 is programmed to the same value. The error message Er 30 appears and can be cancelled with any key. At the same time X0 and X0' are set to 0 and X1 and X1' to 100.

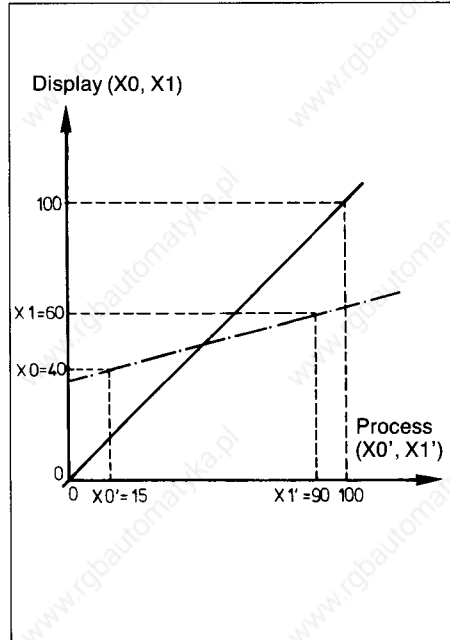

10.3 Calibration of resistance transmitter for valve stroke retransmission (on modulating controller)

The start and end can be calibrated in sub-directory UV03, Code C135 and C136. Resistance transmitters between 0 – 30 Ω min. and 0 – 10 k Ω max. can be connected to the controller.

Calibration of start value:

set transmitter to start position, select Code C135, enter 0 % and press "ENTER".

Calibration of end value:

set transmitter to end position, select Code C136, enter 100 % and press "ENTER".

10.4 Calibration of inputs 1 and 2 with current input 0/4 – 20 mA via external shunt Code 60

Any inaccuracies in the external shunt can be corrected in sub-directory UV03.

Calibration of start value:

apply 0 or 4 mA at the signal input using a current source and enter the indication desired, e.g. 0 %, in Code C131 or C133.

Calibration of final value:

apply 20 mA at the signal input using a current source and enter the indication desired, e.g. 100 %, in Code C132 or C134.

10 ADDITIONAL FUNCTIONS

10.5 Controller with ramp function

It is possible to realise a rising or falling ramp function followed by a soak phase.

WR = ramp setpoint (current setpoint)

W = final value of ramp

RAMP = slope of ramp

On reaching the end of the ramp WR equals W.

The setpoint W is the final value of the ramp which is to be reached at the programmed slope RAMP. The standard display shows the current setpoint.

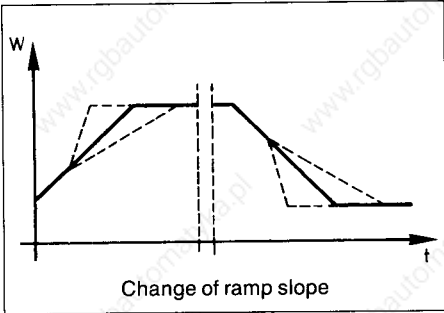

Significance of the setpoint for the limit comparators

The settings of the limit comparators Ik1 to Ik6 during the ramp function normally refer to the ramp setpoint.

Significance of the setpoint for the analogue output:

The setpoint output can be selected in the configuration plane in UV04 analogue output with Code C131; this output then represents the value of the ramp setpoint setting.

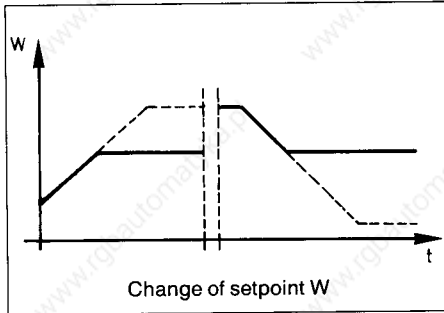

Settings

Parameter	Plane
Ramp function	Configuration plane Code C151
W	Operator plane
RAMP	Parameter plane

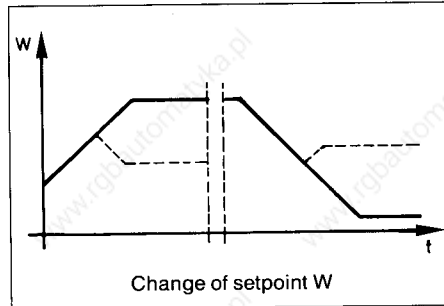

Action after configuration

On starting the configuration the ramp function is interrupted; the outputs become inactive; the actual value changes. When configuration has been completed the controller accepts the actual value measured at that time as the setpoint and continues the ramp function.

10 ADDITIONAL FUNCTIONS

Action on supply failure, sensor short-circuit and failure

If the supply fails the ramp function is interrupted; the outputs become inactive; the process value changes. When the supply is restored the controller accepts the process value measured at that time as the ramp setpoint and continues the ramp function with the parameters selected.

Action during manual operation

During manual operation the automatic control is discontinued. The process value is continuously accepted as the ramp setpoint. On changing to automatic operation the ramp function continues with the parameters selected.

External stop

In the configuration parameter C194 it is possible to configure an external input as external stop. Closing the external contact holds the ramp function, opening the external contact continues the ramp function. When an external stop is recognised, the alphanumerical display configured as setpoint in the standard display flashes for the duration of the external stop.

There is no provision for a stop through a key function; this can however be achieved in practice by programming $RAMP = 0$ from the keys or the serial interface.

(In this case the setpoint in the standard display does not flash.)

10 ADDITIONAL FUNCTIONS

Setting the ramp slope

The parameter plane is reached by pressing the key (*) for 5 sec. This key is located at the bottom left on the controller front panel below the left increment key (not visible). Using the Pgm key select the parameter RAMP (final parameter). The parameters of the various controller models are listed in the parameter table Section 6.2. When one of the increment keys is operated to change the parameter, the parameter name RAMP flashes in the lower display.

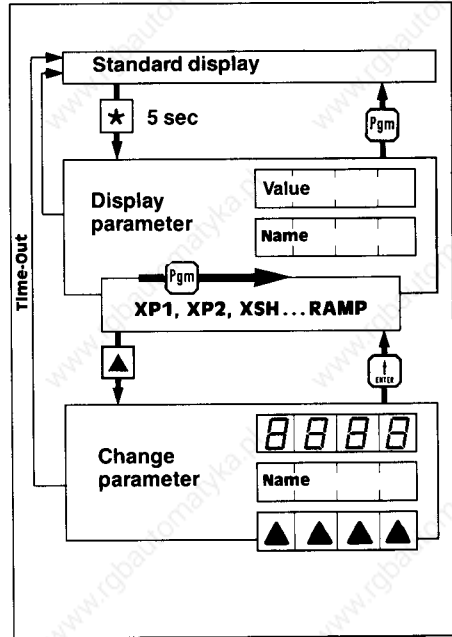

Setting the setpoint (final value) of the ramp

In the standard display the upper display shows the actual value and the lower display the setpoint. On pressing the Pgm key the upper display shows the setpoint, the lower display the parameter name W. The setpoint can be changed with the 4 increment keys. After an increment key has been operated the parameter name W is flashing. The value is entered with the ENTER key.

The controller starts up and begins the ramp function

If there has been no input for 30 sec the controller automatically returns to the standard display (Time-out)

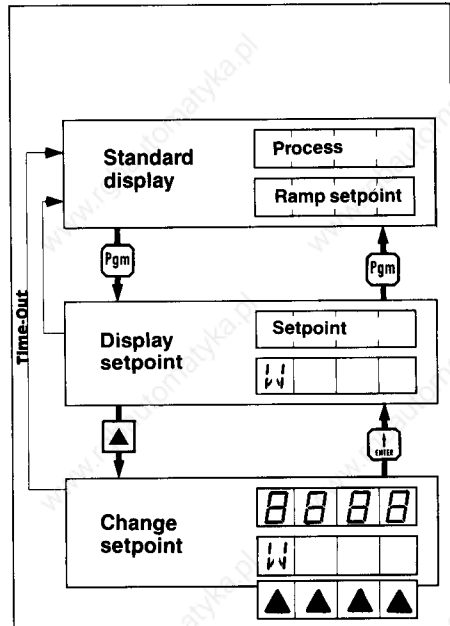

10.6 Function of logic inputs

The following functions can be realised through floating contacts (terminals 0, 17, 18). The desired functions can be configured in UV09, Code 194.

There is a choice of using either contact 1 (0/17) or contact 2 (0/18) for the function.

It is not permissible to use both contacts for the same function.

- (1) Start of self-optimisation
- (2) Changeover auto/manual
- (3) Manual mode blocked
- (4) Keys blocked
- (5) External stop on ramp function

With function 2 it is necessary for the switch S301.3 to be in the ON position (bottom position) (see Section 9).

10.7 Humidity controller

Function: the relative humidity is measured according to the psychrometric principle. The measurement is not dependent on the reference temperature.

Input 1 (Pt100/500) – wet temperature

Input 2 (Pt100/500) – dry temperature

The humidity controller only operates when the dry temperature is within the range 0 °C to 100 °C and when the relative humidity calculated from the corresponding wet temperature is between 0 % and 100 % rH.

Display: the numerical display indicates the relative humidity in %.

The master temperature (dry temperature) or some other variable can be indicated on the alphanumeric display.

Controller type: all controller types can be configured.

10.8 Ratio input

When used as ratio controller the instrument operates with two current inputs 0(4)–20 mA, with the ratio adjustable within the range 0.01–9.99. Either the process value of input 1 (slave) or the ratio can be displayed in the standard setting (see configuration plane UV08 display).

Process variables, setpoints and limit values of the limit comparators are indicated with two decimal places.

10.9 Compensation of external disturbance

The controller is capable of dealing with external disturbances. The signal 0/4–20 mA or 0–10 V is fed into the controller through input 4. The disturbance acts on the valve stroke of the controller which is increased or decreased by a defined amount in the presence of a disturbance signal. The effect of the disturbance can be set in configuration plane UV02 Code C12A and C12B within the range –100 % to +100 %, for example.

Example:

Disturbance signal 0–20 mA = 0 %–50 %, i.e. if the disturbance signal is 10 mA the instantaneous output signal is increased by 25 %.

On the modulating controller the change refers to the actuator in conjunction with the actuator stroke time.

Example:

Actuator stroke time 100 sec, disturbance signal 0–20 mA = 0–100 %, i.e. with a disturbance signal of 10 mA relay Xk1 is switched on for 50 sec, the actuator is opened further.

11 OPTIMISATION

Optimum adjustment means:

1. Good start-up action, i.e. start-up curve as steep as possible without overshoot.
2. Good disturbance and control correction, i.e. to ensure rapid control action without oscillation in case of an external disturbance or if the setpoint is changed.

When precise process characteristics are available the control parameters for a defined operating point can be determined precisely by an involved mathematical procedure. In practice, however, precise characteristics are rarely available, and practical adjustment criteria have therefore been developed which have proved satisfactory.

Even here the assumed conditions (e.g. sudden changes of the disturbance or setpoint at the loop input) are in most cases only approximately correct so that the results obtained can only be considered as a rough indication.

In practice it is useful to record a curve of the process variable under operating conditions in order to ascertain the optimum setting by stepwise changes of one parameter at a time. A basic setting for controllers with PID action, based on parameter values measured, can be obtained by the procedure described below.

11 OPTIMISATION

Oscillation method according to "ZIEGLER" and "NICHOLS"

This method applies to processes which may be rendered unstable for brief periods (T_g/T_u at least 3). The controller is operated initially with the following settings: on switching controllers PD action with minimum T_v and C_Y ; on proportional controllers P action; X_{p1} on maximum. The proportional band X_p is then reduced slowly (by increasing the controller gain) to determine the stability limit at which the process performs undamped oscillations of constant amplitude. This test gives

- the critical proportional band X_{pk}
- the critical oscillation period T_k

The optimum settings are then:

$$X_p = 1.7 X_{pk} \quad T_n = 0.5 T_k$$

$$T_v = \frac{T_n}{4.5}$$

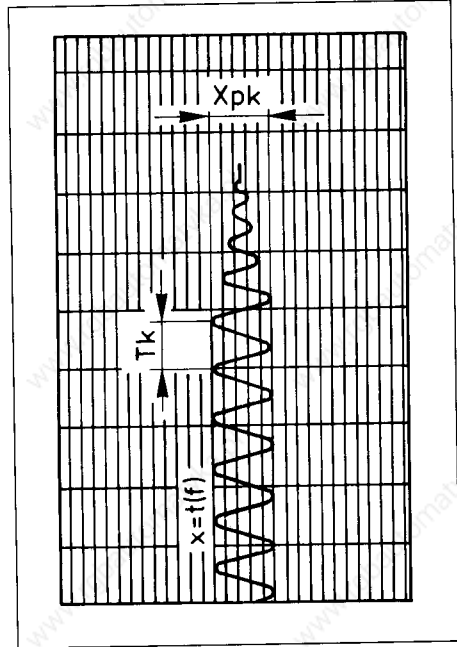

Adjustment according to the process characteristics

Not all control loops can be rendered unstable for brief periods. This method is therefore based on the process loop data. The transfer function (response to a sudden setting or disturbance change) is used to evaluate the following characteristic values:

K_s = process transfer coefficient

$$K_s = \frac{\Delta x}{\Delta y} = \frac{\text{output change}}{\text{input change}}$$

T_u = delay time and

T_g = response time

The controllability of the process loop can be estimated from the ratio T_u/T_g .

For T_u/T_g less than 0.1	satisfactory control
0.1–0.3	just controllable
more than 0.3	difficult to control

11 OPTIMISATION

The transfer function should be recorded near the operating point (setpoint). The input to the process is changed suddenly at time t_0 by an amount Δy within the total adjustment range Y_h (for example 10 % of Y_h). The result is a transfer function with values for Δx , T_u and T_g .

Optimisation according to CHIEN, HRONES and RESWICK

Aperiodic control action of minimum duration, optimised for control

$$X_p = 1.7 \frac{T_u}{T_g} \cdot K_s \cdot Y_h s$$

$$T_n = T_g$$

$$T_v = 0.5 T_u$$

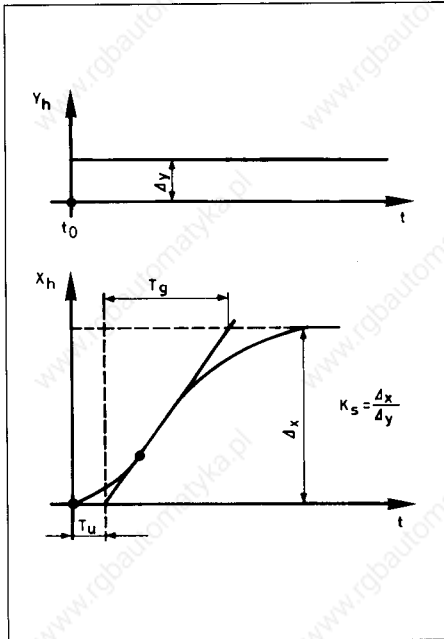

11 OPTIMISATION

If the power supplied cannot be changed in steps the transfer function is recorded with a 100 % change in power. As the process does not always permit this due to technical reasons there is another possibility for determining the control parameters. It evaluates the maximum rate of rise of the transfer function.

$$V_{max} = \frac{\Delta y}{\Delta t}$$

$$X_p = 0.83 V_{max} \cdot T_u$$

This gives the following values for PID controllers based on the example above:

$$\Delta t = 3 \text{ min}$$

$$\Delta x = 90 \text{ }^\circ\text{C} \quad V_{max} = \frac{\Delta x}{\Delta t} = \frac{90 \text{ }^\circ\text{C}}{3 \text{ min}} = 30 \frac{\text{ }^\circ\text{C}}{\text{min}}$$

$$X_p = 0.83 \cdot 30 \frac{\text{ }^\circ\text{C}}{\text{min}} \cdot 2 \text{ min}$$

$$X_p = 49.8 \text{ }^\circ\text{C}$$

$$T_n = 2 T_u = 2 \text{ min}$$

$$T_v = \frac{T_n}{4.5} = 27 \text{ sec}$$

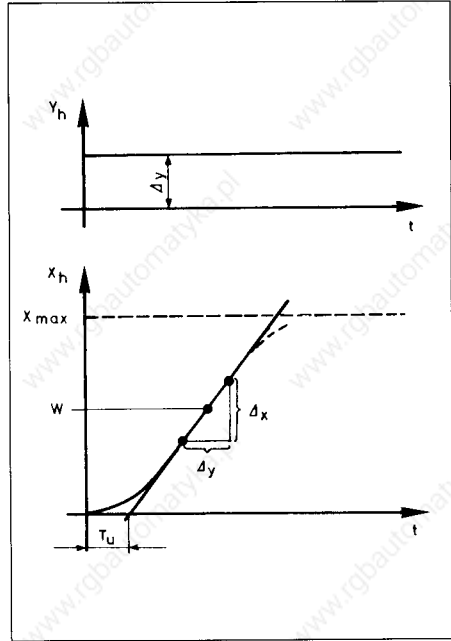

Empirical rules for parameter setting

Control action	Setting
P	$X_p = V_{max} \cdot T_u(^\circ\text{C})$
PI	$X_p = 1.2 \cdot V_{max} \cdot T_u(^\circ\text{C})$ $T_n = 3.3 T_u$
PD	$X_p = 0.83 \cdot V_{max} \cdot T_u(^\circ\text{C})$ $T_v = 0.25 \cdot T_u(\text{min})$
PID	$X_p = 0.83 \cdot V_{max} \cdot T_u(^\circ\text{C})$ $T_n = 2 \cdot T_u(\text{min})$ $T_v = T_n/4.5(\text{min})$
PD/PID	$X_p = 0.4 \cdot V_{max} \cdot T_u(^\circ\text{C})$ $T_n = 2 \cdot T_u(\text{min})$ $T_v = 0.4 \cdot T_u(\text{min})$

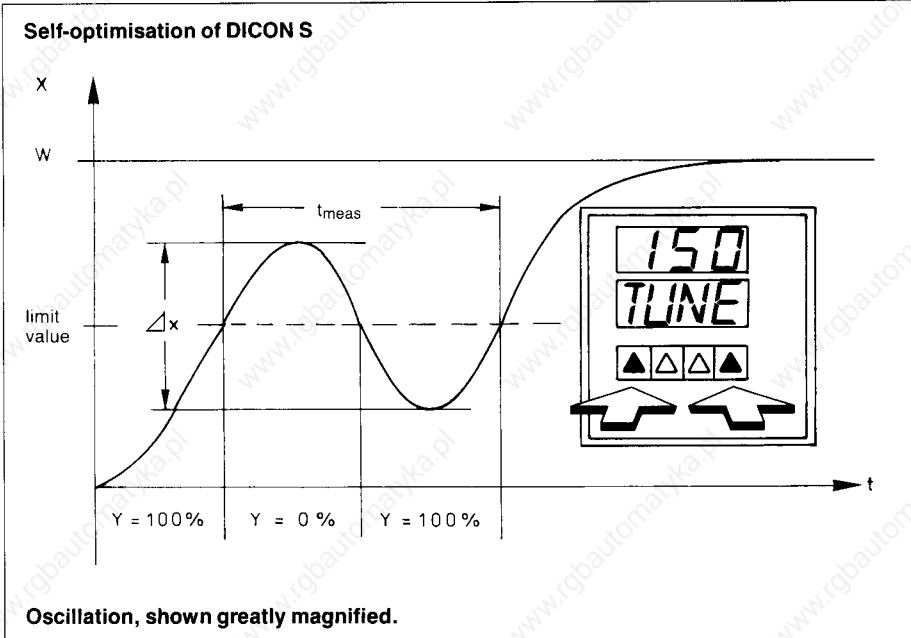

The controller can also be supplied with self-optimisation facility (Extra Code). This applies to single and double setpoint controllers as well as to proportional controllers. The optimisation procedure is based on the "Ziegler" and "Nichols" adjustment rules. The controller is optimised for setpoint response. The setpoint response of a control loop refers to the change in the process variable for a sudden change in the setpoint.

A condition for activating self-optimisation is a difference between process and setpoint of at least 10% of the control span; this is necessary in order to achieve useful results.

The optimisation process is started by simultaneously pressing the right and left increment keys. During optimisation the word "TUNE" is flashing in the alphanumerical display. The controller output signal is set to maximum ($Y = 100\%$) or minimum ($Y = 0\%$) depending on whether the setpoint is above or below the process variable. When half the difference (limit value) between process and setpoint has been reached the output signal Y is reversed.

After the overshoot or undershoot the process passes again through the limit value. The output signal Y is reversed once more followed by another undershoot or overshoot. The measuring process is terminated after the limit value has been reached again.

The calculated control parameters are automatically transferred to the parameter plane of the controller and the control process begins.

From the difference between the maximum and the minimum of the amplitude (Δx) and the duration of the period (t_{meas}) the controller calculates:

$$XP1, XP2 = XP1, Tn, Tv = Tn/4$$

$$CY = Tn/10, CY2 = CY1$$

The parameters determined by optimisation can always be called up and modified.

After the start of self-optimisation the controller is automatically set to PID action!

The optimisation procedure can be aborted at any time with the two centre-increment keys.

11 OPTIMISATION

Checking the optimisation for PID action

The optimum adjustment of the controller to the process can be checked by recording a start-up with closed process loop.

The diagrams below indicate possible incorrect adjustments and the correction required.

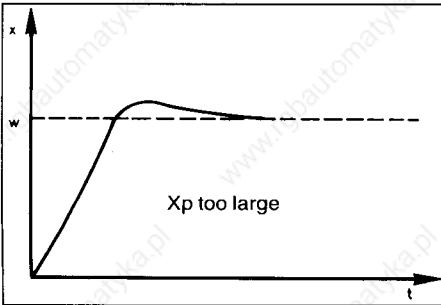
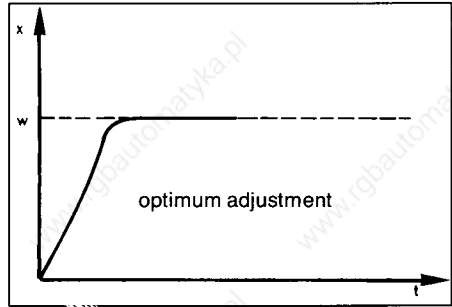
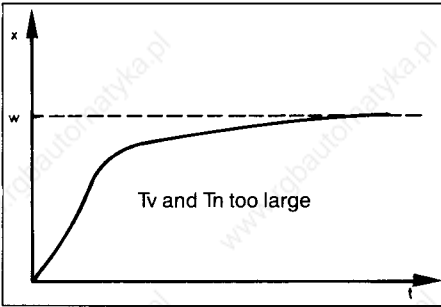
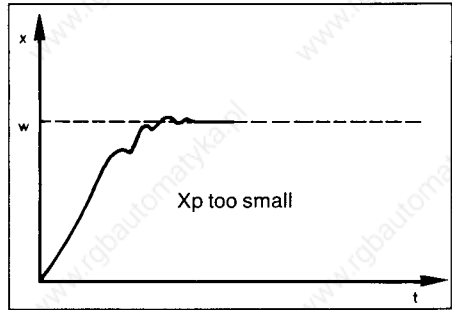
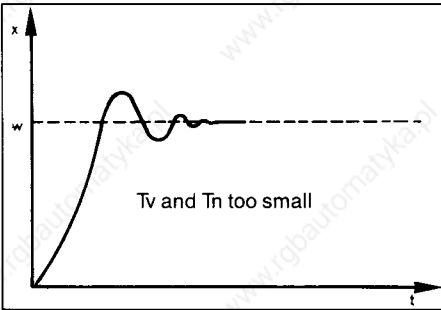

This shows that increased X_p and increased T_n both result in a more stable and more sluggish control action. Smaller X_p or T_n produces a less damped control action.

mm	inch	mm	inch
0.8	0.031	79	3.11
4.8	0.19	91.6	3.61
12	0.47	92 ^{+0.5}	3.62 ^{+0.02}
25.8	1.02	96	3.78
66	2.60	111	4.37
73	2.87	121.5	4.78