

# MOVITRAC® 31C Frequency Inverters

Operating Instructions

Edition 07/2000



08/198/96

0922 9019 / 102000



# SEW EURODRIVE

**Always follow the warning and safety notes contained in this user manual! Safety notes are:**



**Electrical hazard**, e.g. when working on live equipment.



**Mechanical hazard**, e.g. when working on hoists.



**Important instructions** for safe and fault-free operation.



A **requirement for fault-free operation** and fulfillment of any rights to claim under guarantee is that these **instructions and remarks** are followed. **Therefore read these instructions carefully** before you start working with the unit!

These **operating instructions** contain **important information for servicing**. They should therefore **be kept in the vicinity of the unit**.



### Application Restrictions

The MOVITRAC® 31C units are frequency inverters for industrial and commercial drive systems for operation of three-phase AC squirrel-cage asynchronous motors. Other loads must not be operated with the inverters.

The installation site must be free of dust, dry (without danger of moisture condensation) and lockable (e.g. switch cabinet). All specifications concerning technical data and permissible conditions at the equipment location must be observed.

Where applicable, commissioning (starting normal operation) is prohibited, unless the machine complies with the EMC guideline 89/336/EWG and the conformity of the finished product with the machine guideline 89/392/EWG is verified (observe EN 60204).

### Unless otherwise specifically indicated, the following is prohibited:

- Implementation in areas subject to explosion hazards
- Implementation in the vicinity of oils, acids, gas, fumes, dusts, radiation, etc.
- Implementation in non-stationary applications where mechanical vibration and impact loads occur which exceed the limits stipulated by EN50178.
- Implementation in applications where the inverter alone (without a higher-level safety system) is responsible for safety tasks which must guarantee the safety of persons and machinery.



### Disposal (please observe the applicable waste disposal regulations):

Depending on the material they are made of, unit components are to be disposed of in accordance with the applicable waste disposal regulations for: electronics waste (pcbs), plastic material (housing), sheet metal, copper, etc.

**For further technical information as well as selection notes please refer to the MOVITRAC® 31C Frequency Inverter Catalog, publication no. 0922 9116.**

For further information about the synchronous operation control option, the IPOS positioning control option and the fieldbus options (PROFIBUS and INTERBUS) please refer to the respective user manuals.

	<b>Page</b>
<b>1 Safety Notes .....</b>	<b>4</b>
<b>2 Installation .....</b>	<b>5</b>
2.1 Type designation, nameplate and option label .....	5
2.2 MOVITRAC® 31C, Size 0 .....	6
2.3 MOVITRAC® 31C, Sizes 1 and 2 .....	7
2.4 MOVITRAC® 31C, Sizes 3 and 4 .....	8
2.5 Installation instructions .....	9
2.6 Installation for electromagnetic compatibility .....	10
2.7 UL-compliant installation .....	11
2.8 Wiring diagram for the basic unit .....	12
2.9 Assignment of braking resistors, chokes and filters .....	15
2.10 MOVITRAC® 31C, size 0 with braking resistor .....	18
2.11 Connecting the RS-232 serial interface (USS21A options) .....	19
2.12 Connecting the RS-485 serial interface (USS21A option) .....	19
2.13 Installation of option cards .....	20
2.14 Wiring diagram and terminal description for the FEA31C option .....	21
2.15 Wiring Diagram and Terminal Description for the FIO31C Option .....	22
2.16 Wiring diagram and terminal description for the FEN31C/FPI31C option .....	23
2.17 Wiring diagram and terminal description for the FIT31C option .....	24
2.18 Connecting the incremental encoder .....	25
<b>3 Startup .....</b>	<b>26</b>
3.1 Preliminary work and aids .....	26
3.2 Short-cut startup with the FBG31C keypad .....	27
3.3 Starting the motor .....	29
3.4 Startup examples .....	32
3.5 Complete parameter list .....	39
<b>4 Operation and Service .....</b>	<b>47</b>
4.1 Operating displays .....	47
4.2 Fault information .....	51
4.3 Fault signals .....	52
4.4 SEW Electronics Service .....	55
<b>5 Technical Data .....</b>	<b>56</b>
5.1 Basic units .....	56
5.2 MOVITRAC® 31C...-233 (230 V Units) .....	57
5.3 MOVITRAC® 31C...-503 (400/500 V Units) .....	59
5.4 MOVITRAC® 31C electronics data .....	64
<b>6 Index .....</b>	<b>65</b>

Any revisions to edition *01/99* are indicated by a gray bar in the margin.



## 1 Safety Notes

### Installation and startup

- **Never install or start-up damaged products.** Make a complaint about the damage to the shipping company immediately.
- **Installation, startup and servicing** of the inverter may only be performed by **qualified personnel** with the relevant training in accident prevention, in compliance with the valid regulations (e.g. EN 60204, VBG 4, DIN VDE 0100/0113/0160).
- **The relevant instructions for installation and startup of the motor and brake must be observed!**
- **Protective measures and equipment** must be chosen according to the **applicable standards** (e.g. EN 60204 or EN 50178).  
Necessary protective measure: Unit must be grounded.  
Necessary protective equipment: Overcurrent protection devices (fuses).
- **The unit meets all requirements for secure separation** of power and electronics terminals according to EN 50178. To guarantee safe and reliable separation, all **current circuits connected** must also meet the **requirements for safe and reliable disconnection**.
- Ensure that the **connected motor does not start on its own when the unit is connected to the mains** by taking **appropriate measures (e.g. removing the electronics terminal block)**.

### Operation and service

- Before **removing the front cover**, the **inverter must be disconnected from the mains. Dangerous voltages** can remain present for **up to 10 minutes after the power supply has been turned off**.
- When the **front cover is removed** the unit has enclosure class **IP 00. Dangerous voltages** are present on all subassemblies except the control electronics. The unit must be kept closed during operation.
- Dangerous voltages are present on the **output terminals** and the connected **cables and motor terminals when the unit is in operation**. This is also the case when the output stage is disabled and the motor is at rest.
- If the **operating indicator LED V1** or any of the other status indicators **are off**, it is **not an indication** that the unit is disconnected from the mains or is **de-energized**.
- **Internal safety functions** in the unit or **mechanical blocking** can cause a **motor standstill. Remedying the cause of the fault or resetting** the unit can cause the drive **to restart by itself**. If, for safety reasons, **this is not admissible** for the driven machine, the **inverter must be disconnected from the mains** before remedying the fault. In this case, the activation of the **Auto-Reset function (P860)** is **prohibited**.

## 2 Installation

### 2.1 Type designation, nameplate and option label

Type designation, example:

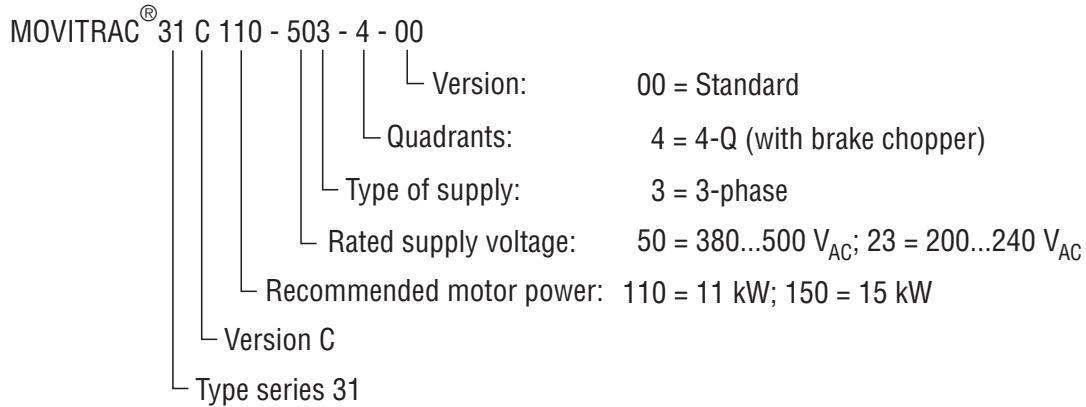

01552AEN

Nameplate, example:

The nameplate is mounted on the side of the unit.

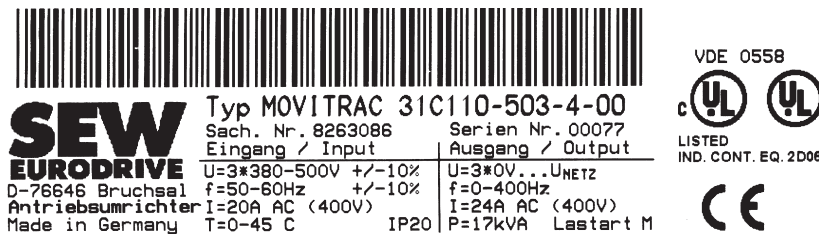

00593AXX

Fig. 1: Nameplate

Option label, example:

All MOVITRAC<sup>®</sup> 31C inverters come with an option label specifying the option cards installed at the plant. If an option card is installed at a later date, the option must be marked on the option label.  
Example: MOVITRAC<sup>®</sup> 31C with FEA31C.

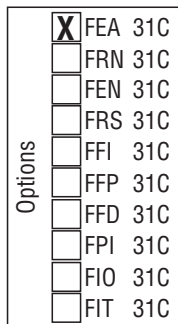

00596AEN

Fig. 2: Option label

## 2.2 MOVITRAC® 31C, Size 0

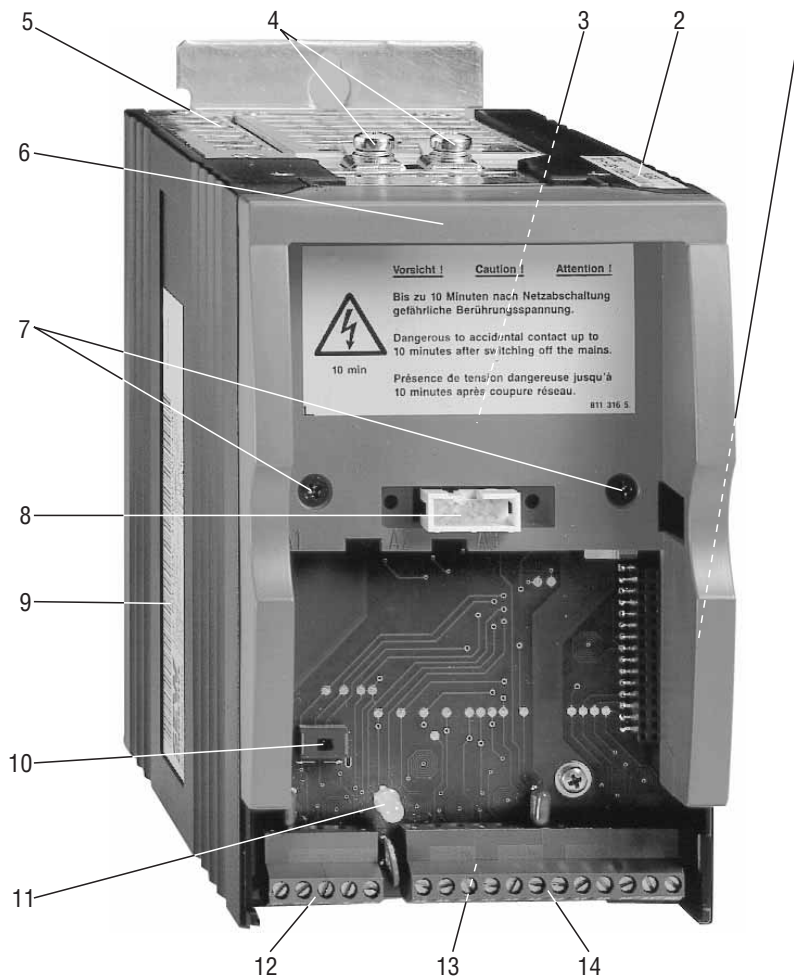

Fig. 3: MOVITRAC® 31C, size 0 without lower cover

00592BXX

- 1 Service label (not visible)
- 2 Type label
- 3 X1: Power section terminals (not visible) for mains and motor connections also for braking resistor in 4-Q mode.
- 4 Terminal for PE (⊕)
- 5 Mounting bracket for optional braking resistor
- 6 Upper cover
- 7 Retaining screws for upper cover; this cover must be removed for access to power terminal strip X1 .
- 8 X4: Slot for operating options
- 9 Nameplate
- 10 S1: Switch to select  $n_{\text{set}}$  :10 V / 20 mA; accessible below operating option.
- 11 V1: LED display
- 12 X2: Electronics terminal strip
- 13 Electronics shielding terminals (not visible)
- 14 X3: Electronics terminal strip

### 2.3 MOVITRAC® 31C, Sizes 1 and 2

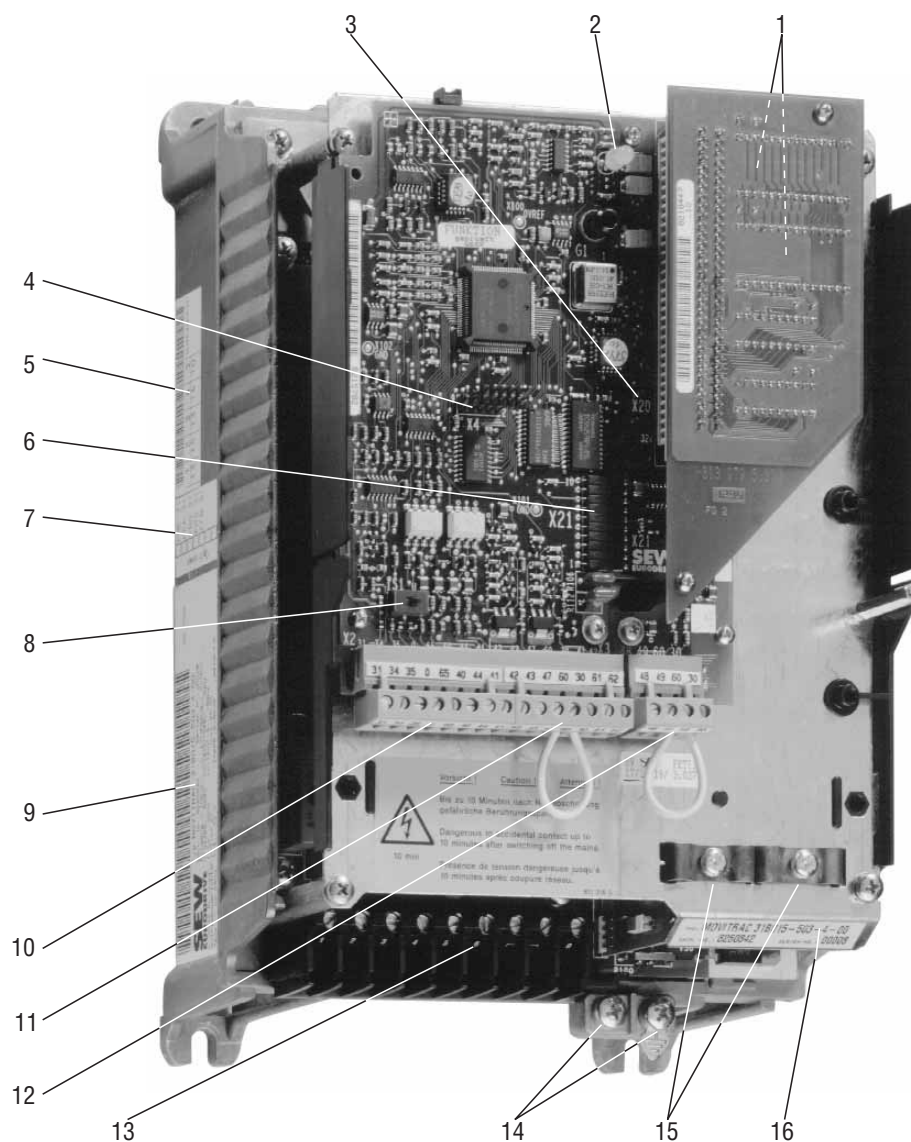

Fig. 4: MOVITRAC® 31C, sizes 1 and 2 without housing

00597BXX

- 1 System EPROMs
- 2 V1: LED display
- 3 X20: Slot for option cards
- 4 X4: Slot for operating options
- 5 Service label
- 6 X21: Slot for option cards
- 7 Option label
- 8 S1: Switch to select  $n_{set}$  : 10 V / 20 mA; accessible below operating option.
- 9 Nameplate
- 10 X2: Electronics terminal strip
- 11 X3: Electronics terminal strip
- 12 X14: Electronics terminal strip
- 13 X1: Power section terminals for mains and motor connections also for braking resistor in 4-Q mode.
- 14 Terminal for PE (⊕)
- 15 Electronics shielding terminals
- 16 Type label



## 2.4 MOVITRAC® 31C, Sizes 3 and 4

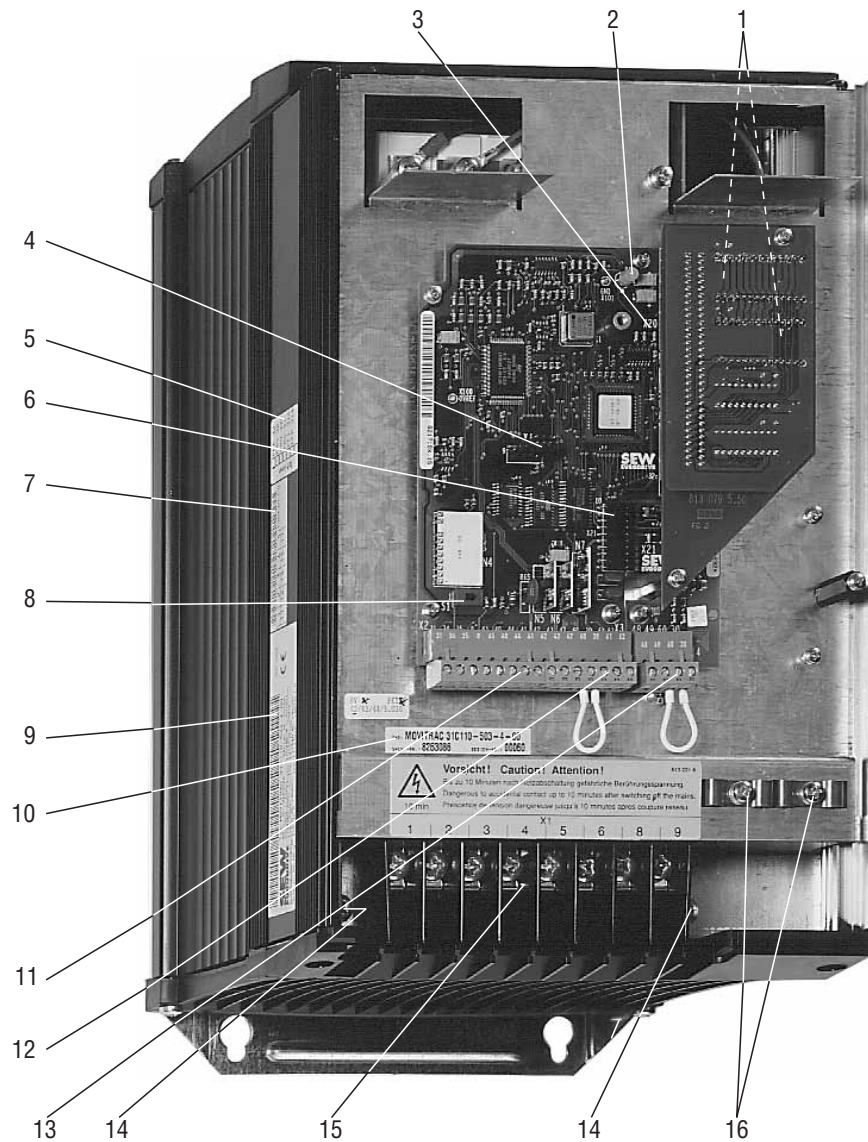

Fig. 5: MOVITRAC® 31C, sizes 3 and 4 without housing

00061 BXX

- 1 System EPROMs
- 2 V1: LED display
- 3 X20: Slot for option cards
- 4 X4: Slot for operating options
- 5 Option label
- 6 X21: Slot for option cards
- 7 Service label
- 8 S1: Switch to select  $n_{set}$  10 V / 20 mA; accessible below operating option.
- 9 Nameplate
- 10 Type label
- 11 X2: Electronics terminal strip
- 12 X3: Electronics terminal strip
- 13 X14: Electronics terminal strip
- 14 X1: Terminal for PE (⊕)
- 15 Power section terminals for mains and motor connections also for braking resistor in 4-Q mode.
- 16 Electronics shielding terminals



## 2.5 Installation instructions

**Safety instructions (→ Sec. 1, Page 4) must be strictly observed during installation!**



- Use only original connection components!  
Observe the **tightening torques** of the MOVITRAC® 31C power terminals:  
Size 0 → 1.5 Nm (13.3 lb.in) / Size 1 → 0.6 Nm (5.3 lb.in) /  
Size 2 → 1.5 Nm (13.3 lb.in) / Sizes 3 and 4 → 3.5 Nm (31 lb.in)
- **Observe minimum required ventilation space** of units (sufficient cooling)! Leave a minimum clearance of **100 mm (4 in) above and below** the unit. No lateral clearance required.
- Units must be **mounted vertically**. Other mounting positions are not permissible!
- The MOVITRAC® 31C is designed for operation on **voltage power systems with a directly earthed neutral point (TN and TT power systems)**.  
However, operation on voltage power systems with a non-earthed neutral point (for example **IT power systems**) is also **permitted**. SEW recommends using earth-leakage monitors with pulse-code measurement in voltage systems with non-earthed neutral points (IT systems). This prevents the earth capacitance of the inverter from inadvertently triggering the earth-leakage monitor. The EMC limit values for interference emission are not specified for voltage systems with a non-earthed neutral point (IT power systems). Line filter effectiveness is extremely limited.
- With **more than four units** on a single **mains contactor** dimensioned for the total current of all units: **connect a 3-phase line choke** in series to limit the inrush current.
- Run **power cables** and **electronic leads** in separate cable ducts.
- **Mains power cable**: based on input rated current  $I_{in}$  at rated load (Data → Sec. 5).
- **PE mains connection (→ EN 50178)**: If cross-section of PE conductor is  $< 10 \text{ mm}^2$  (AWG8), a second lead with the cross-section of the mains connection cable must be run parallel to the PE conductor via separate terminals or a copper PE conductor with a cross-section of  $10 \text{ mm}^2$  (AWG8) must be used. If the mains connection cable is  $\geq 10 \text{ mm}^2$  (AWG8), a copper PE conductor with the cross-section of the mains connection cable must be used. During operation leakage currents  $> 3.5 \text{ mA}$  can occur.
- **Motor cable**: based on the output rated current  $I_N$  (Data → Sec. 5).
- The **input fuses** must be installed at the beginning of the power cable, directly after the busbar junction. (→ Sec. 2.8.1: F11/F12/F13). Use fuse types D, DO, NH or power circuit breakers.
- An **earth leakage circuit-breaker** is **not permissible as the sole protection device, as leakage currents  $> 3.5 \text{ mA}$**  can occur during normal inverter operation.
- **Alternate operation of two motors from one inverter**: a changeover contactor must be provided for each of the two motors cables. **Changeover contactors may only be actuated when the inverter is disabled!**
- Only connect a **resistive/inductive load (motor)** to the **inverter output**, no capacitive load!
- **Recommendation**: Observe a minimum switch-off time of 10 s for the mains contactor K11.
- **Binary inputs** are **opto-isolated**. The **binary outputs** are **short-circuit-proof**, but **not external-voltage proof**. Connecting an **external voltage source** to the binary outputs can **damage** them!
- **Connection of braking resistors**: Use two closely adjacent twisted wires or a 2-core shielded power cable, with a cross-section based on the inverter rated current. (Data → Sec. 5). Protect the braking resistor with a bimetallic relay (→ Sec. 2.8.1: F16) tripping current according to Technical Data of Braking Resistors (→ Sec. 2.9).
- **Operation braking resistors**: In normal operation the connection leads to the braking resistor carry a high DC voltage (approx. 900 V). If required, mount braking resistors in flat-pack design with appropriate touchguard. When loaded with  $P_N$ , the **surface** of the braking resistor reaches **high temperatures**. Choose the mounting position accordingly (for example on the top of the switch cabinet).

## 2.6 Installation for electromagnetic compatibility

- The control leads must be shielded.
- The shield must be earthed by the most direct route possible, with a wide-area contact to ground at both ends. If necessary, one end may be earthed via an interference suppression capacitor (220 nF/50 V) to prevent earth loops. In the case of double-shielded cable, earth the outer shield at the MOVITRAC<sup>®</sup> side, and the inner shield at the other end.
- Running the cables in separate, earthed metal ducts or conduits is also effective as shielding.
- Connect the MOVITRAC<sup>®</sup> and all accessories to earth in compliance with high frequency requirements (wide-area metallic contact between unit housing and ground, i.e. switch cabinet mounting plate not painted).
- EMC module EF...-503 (contains input filter and output choke)
  - EF014/030/075-503: Mount the EMC module together with the MOVITRAC<sup>®</sup> 31C unit onto the conductive mounting surface in the switch cabinet.
  - EF220/450-503: First mount the EMC module onto the conductive mounting surface with four screws in the switch cabinet, then mount the MOVITRAC<sup>®</sup> 31C unit with the four M6 screws onto the EMC module.
- Input filter NF...-...
  - Mount the NF.. input filter close to the corresponding MOVITRAC<sup>®</sup>, but **outside the minimum ventilation space required**.
  - Keep the connection cable between the input filter and the MOVITRAC<sup>®</sup> as short as possible: a maximum lead length of 400 mm (15 in) is permissible. Unshielded, twisted-conductor cable is sufficient. Use also unshielded cables for the connection between the mains and the input filter.
  - If multiple inverters are connected to one input filter, the input filter must be connected either directly at the switch cabinet input or in the immediate vicinity of the inverter. The correct input filter is determined from the total current of all inverters.
- Output choke HD...
  - Mount output choke close to MOVITRAC<sup>®</sup> **outside minimum ventilation space**.
  - Guide only the three phases U, V and W through the output choke! Do not guide the PE conductor through the output choke!

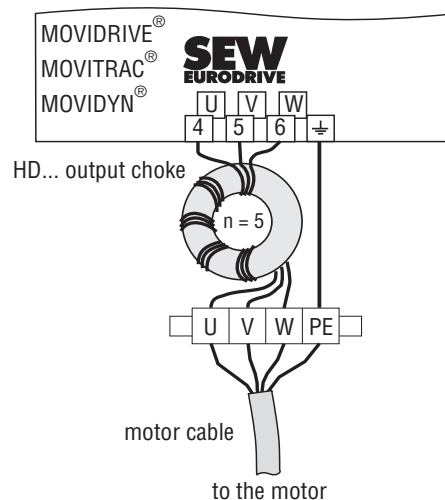

Fig. 6: Connection output choke HD...

00569CEN

## 2.7 UL-compliant installation

For UL-compliant installation observe the following instructions:

- Use only copper leads as connection cable with the following temperature range:
  - for MOVITRAC<sup>®</sup> 31C005...300 temperature range 60/75°C.
  - for MOVITRAC<sup>®</sup> 31C370/450 temperature range 75/90°C.
- The permissible tightening torque values of the MOVITRAC<sup>®</sup> 31C power terminals are as follows:
  - Size 0 → 1.5 Nm (13.3 lb.in)
  - Size 1 → 0.6 Nm (5.3 lb.in)
  - Size 2 → 1.5 Nm (13.3 lb.in)
  - Size 3 → 3.5 Nm (31 lb.in)
  - Size 4 → 3.5 Nm (31 lb.in)
- MOVITRAC<sup>®</sup> 31C frequency inverters are designed for operation on voltage systems with earthed neutral points (TN and TT systems) which can provide a maximum current according to the table below and have a maximum voltage of 240 V<sub>AC</sub> for the MOVITRAC<sup>®</sup> 31C...-233 (230 V units) and 500 V<sub>AC</sub> for MOVITRAC<sup>®</sup> 31C...-503 (400/500 V units). The performance data of fuses must not exceed the values given in the following tables.
- Use only tested devices with limited output voltage ( $V_{max} = 30 V_{DC}$ ) and limited output current ( $I \leq 8 A$ ) to establish an external 24 V<sub>DC</sub> low-voltage current-limited power supply.

230 V Units:

MOVITRAC <sup>®</sup> 31C...-233		max. current	max. mains voltage	fuses (max.)
005/011	(Size 0)	5 000 A <sub>AC</sub>	240 V <sub>AC</sub>	20 A / 600 V
008/015/022	(Size 1)	5 000 A <sub>AC</sub>	240 V <sub>AC</sub>	32 A / 600 V
037	(Size 2)	5 000 A <sub>AC</sub>	240 V <sub>AC</sub>	63 A / 600 V
055/075	(Size 3)	5 000 A <sub>AC</sub>	240 V <sub>AC</sub>	110 A / 600 V

400/500 V Units:

MOVITRAC <sup>®</sup> 31C...-503		max. current	max. mains voltage	fuses (max.)
005/007/011/014	(Size 0)	5 000 A <sub>AC</sub>	500 V <sub>AC</sub>	16 A / 600 V
008/015/022/030	(Size 1)	5 000 A <sub>AC</sub>	500 V <sub>AC</sub>	30 A / 600 V
040/055/075	(Size 2)	5 000 A <sub>AC</sub>	500 V <sub>AC</sub>	63 A / 600 V
110/150/220	(Size 3)	5 000 A <sub>AC</sub>	500 V <sub>AC</sub>	175 A / 600 V
300/370/450	(Size 4)	10 000 A <sub>AC</sub>	500 V <sub>AC</sub>	400 A / 600 V

### Note:

UL certification is not valid for operation on voltage systems with non-earthed neutral points (IT systems).

## 2.8 Wiring diagram for the basic unit

### 2.8.1 Wiring of power section and brake

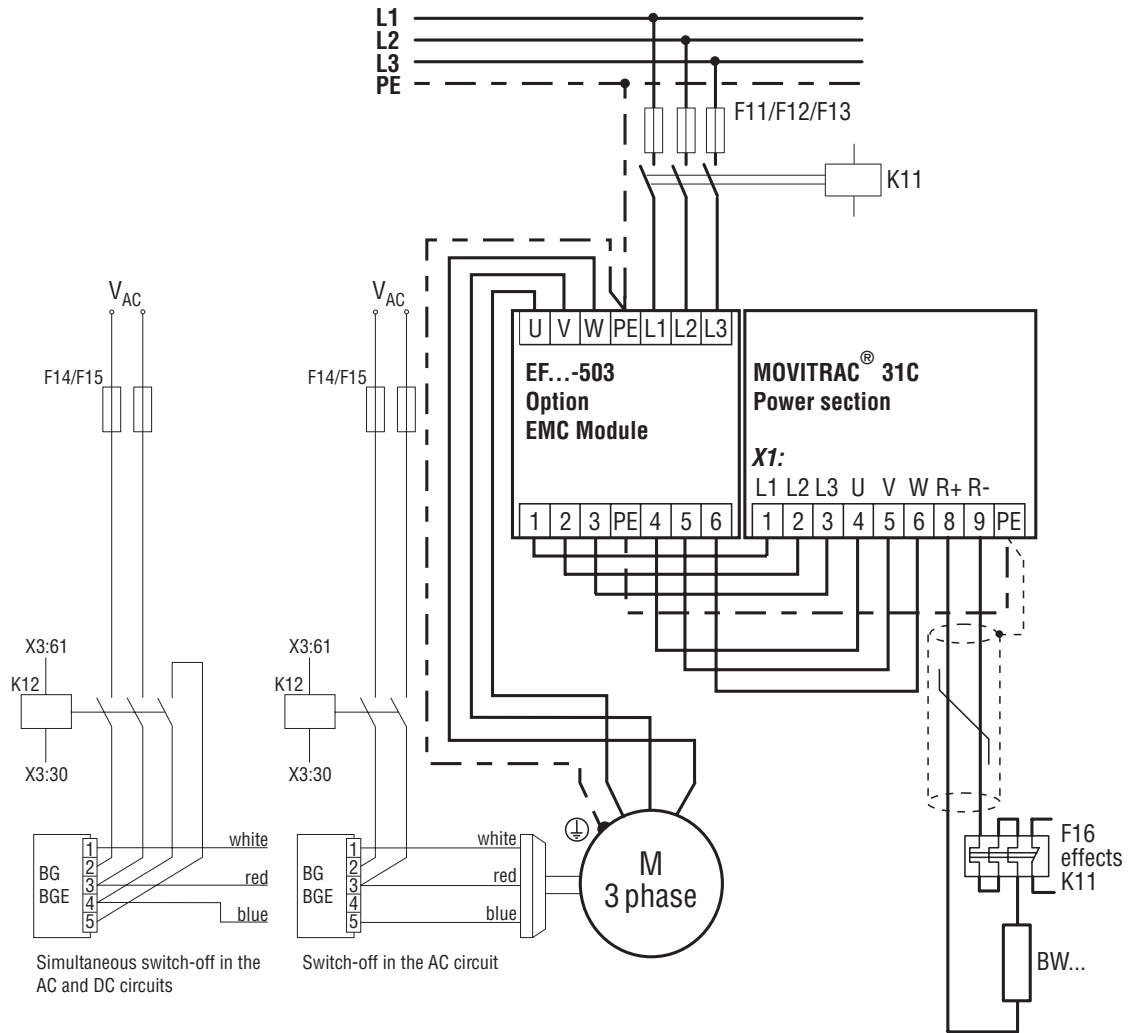

Fig. 7: Wiring diagram power section and brake

01553AEN



**The connection of the brake rectifier requires a separate mains supply cable; supply from the motor voltage is not permissible!**

For all hoist applications always use switch-off in AC **and** DC circuits of the brake:

When an inverter is connected (PWM generated output voltage), the supply cables for the brakes must be routed separately from the other power cables.

When installing the brake rectifier in the switch cabinet, the connection cables between brake rectifier and brake must be routed separately from other power cables.

Installation together with other cables is only permissible if the other cables are shielded.

Observe the installation regulations for brakes without BG/BGE or BME.

2.8.2 Wiring of processor card

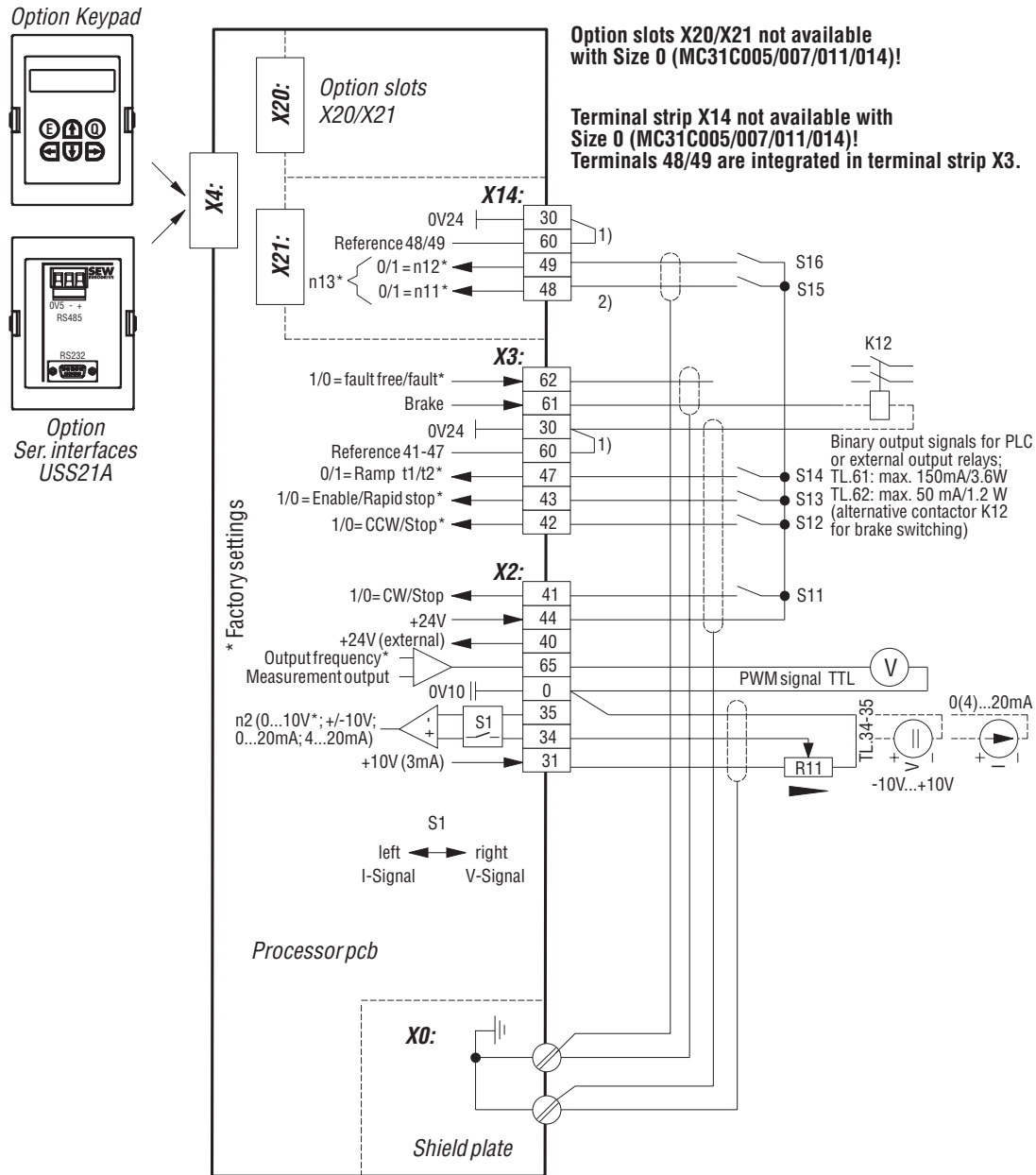

1) Jumper, factory installed; connects reference of the binary inputs with units internal ground.

2) After installing an option in slot X21, the terminals 48/49/60/30 in the basic unit are not available.

- TL. 0 ⊥ 0V10 (Reference potential 10V, analog signals)
- TL. 30 ⊥ 0V24 (Reference potential 24V, binary signals)
- Strip ⊥ Protective earth conductor (Shield)

01 554AEN

Fig. 8: Wiring diagram processor card

### 2.8.3 Functional description of the basic unit terminals

Terminal	Function	
<b>X1:</b> 1/2/3 4/5/6 8 8/9 PE	Mains connection L1, L2, L3 or EF...-503 EMC module TL.1, 2, 3 Motor cable U, V, W or EF...-503 EMC module TL.4, 5, 6 DC link connection for HF... (TL. 7 at HF...-403, TL. V5 at HF...-503): <b>Connect only if <math>f_{PWM} = 12 \text{ kHz}</math> or <math>16 \text{ kHz}</math> and additionally for HF...-403 <math>V_{mains} \leq 400 \text{ V!}</math></b> Braking resistor connection R+, R- Protective earth connection	
<b>X0:</b>	Grounding terminal (cable clips) for screening for electronics control leads (PE potential)	
<b>S1:</b>	Switchover I-signal (0...20mA, 4...20mA) or V-signal (0...10V, $\pm 10\text{V}$ ), factory setting: V-signal	
<b>X2:</b> 31 34/35 0 65 40 44 41	+10V (max. 3mA) for setpoint potentiometer Setpoint input n2 (differential input, reference TL. X2:0) Signal form $\rightarrow$ menu P11_ and switch S1 Reference potential for analog signals Measurement output: suitable for 5V display instruments (Signal types $\rightarrow$ P634/P635), reference TL. X2:0 Input +24V external power supply (supporting voltage depending on options, unit diagnosis for mains OFF) Output +24V auxiliary voltage (max. 250mA) for external switches Binary input 1, fixed assignment: CW/stop	
<b>X3:</b> 42 43 47 60 30 61 62	Binary input 2, factory setting: CCW/stop Binary input 3, Enable/rapid stop Binary input 4, t1/t2 Reference for binary inputs X2:41 and X3:42/43/47 Switching the binary inputs with +24V of X2:44 Switching the binary inputs with ext. voltage 24V: Reference potential for binary signals Binary output 1, fixed assignment: /Brake Binary output 2, factory setting: /Fault	The binary inputs are opto-isolated. Selection possibilities for binary inputs $\rightarrow$ menu P60_ Jumper X3:60-30 Connection X3:60-external ground with jumper X3:60-30 non-isolated without jumper X3:60-30 potential free Max. load: 150mA Max. load: 50mA Selection possibilities $\rightarrow$ menu P611
<b>X14:</b> 48 49 60 30	Binary input 5, n11/n21 Binary input 6, n12/n22 Reference for binary inputs X14:48/49 Reference potential for binary signals	With MOVITRAC <sup>®</sup> 31C Size 0 (005/007/011/014) not available. Terminals 48 and 49 are integrated in terminal strip X3.
<b>X4:</b>	Slot for FBG31C keypad option / USS21A (RS-232 and RS-485) serial interfaces	
<b>X20:</b>	Slot for option cards, FEA31C input/output expansion / FIO31C digital input/output expansion / FES31C synchronous operation / FFP31C, FFI31C and FFD31C fieldbus interfaces With MOVITRAC <sup>®</sup> 31C, size 0 (005/007/011/014) not available.	
<b>X21:</b>	Slot for option cards, FEN31C speed detection / FPI31C position detection / FIT31C TF/TH evaluation With MOVITRAC <sup>®</sup> 31C Size 0 (005/007/011/014) not available.	



## 2.9 Assignment of braking resistors, chokes and filters

### 2.9.1 MOVITRAC® 31C...-233 (230V units)

MOVITRAC® 31C...-233			005	011	008	015	022	037	055	075
Size			0		1			2	3	
<b>Braking resistors</b>			<b>Part number</b>							
BW100-003	$I_{\text{trip}} = 0.5 A_{\text{RMS}}$	826 266 7								
BW100-005	$I_{\text{trip}} = 1.2 A_{\text{RMS}}$	826 269 1								
BW100-002	$I_{\text{trip}} = 1.2 A_{\text{RMS}}$	821 700 9								
BW100-006	$I_{\text{trip}} = 2.3 A_{\text{RMS}}$	821 701 7								
BW039-003	$I_{\text{trip}} = 2.0 A_{\text{RMS}}$	821 687 8								
BW039-006	$I_{\text{trip}} = 3.2 A_{\text{RMS}}$	821 688 6								
BW039-012	$I_{\text{trip}} = 5.0 A_{\text{RMS}}$	821 689 4								
BW039-026	$I_{\text{trip}} = 7.8 A_{\text{RMS}}$	821 690 8								
BW027-006	$I_{\text{trip}} = 2.5 A_{\text{RMS}}$	822 422 6								
BW027-012	$I_{\text{trip}} = 4.4 A_{\text{RMS}}$	822 423 4								
BW012-025	$I_{\text{trip}} = 10 A_{\text{RMS}}$	821 680 0								
BW012-050	$I_{\text{trip}} = 19 A_{\text{RMS}}$	821 681 9								
BW012-100	$I_{\text{trip}} = 27 A_{\text{RMS}}$	821 682 7								
<b>EMC modules</b>			<b>Part number</b>							
EF014-503	$I_D = 5 A_{\text{AC}}$	826 384 1								
EF030-503	$I_D = 10 A_{\text{AC}}$	826 385 X								
EF075-503	$I_D = 20 A_{\text{AC}}$	826 386 8								
EF220-503	$I_D = 60 A_{\text{AC}}$	826 553 4								
<b>Line chokes</b>			<b>Part number</b>							
ND020-013	$\Sigma I_{\text{in}} = 20 A_{\text{AC}}$	826 012 5							A	
ND045-013	$\Sigma I_{\text{in}} = 45 A_{\text{AC}}$	826 013 3							B	
<b>Input filters</b>			<b>Part number</b>							
NF008-443	$V_{\text{max}} = 440 V_{\text{AC}}$	825 721 3				A	A			
NF016-443		825 719 1				B	B	A		
NF025-443		825 718 3						B	A	
NF036-443		825 717 5							B	
<b>Output chokes</b>			<b>Part number</b>							
HD001	$d = 50 \text{ mm (1.97 in)}$	813 325 5	for cable cross-sections 1.5...16 mm <sup>2</sup> (AWG16...6)							
HD002	$d = 23 \text{ mm (0.91 in)}$	813 557 6	for cable cross-sections $\leq 1.5 \text{ mm}^2$ (AWG16)							
HD003	$d = 88 \text{ mm (4.46 in)}$	813 558 4	for cable cross-sections $\geq 16 \text{ mm}^2$ (AWG6)							

A in case of rated operation (100%)

B with variable torque load (125%)

## 2.9.2 MOVITRAC® 31C...-503 (400/500V units)

MOVITRAC® 31C...-503			005	007	011	014	008	015	022	030
Size			0				1			
<b>Braking resistors</b>		Part number								
BW200-003	$I_{\text{trip}} = 0.2 A_{\text{RMS}}$	826 267 5								
BW200-005	$I_{\text{trip}} = 0.5 A_{\text{RMS}}$	826 270 5								
BW100-003	$I_{\text{trip}} = 0.4 A_{\text{RMS}}$	826 266 7								
BW100-005	$I_{\text{trip}} = 0.8 A_{\text{RMS}}$	826 269 1								
BW100-002	$I_{\text{trip}} = 0.7 A_{\text{RMS}}$	821 700 9								
BW100-006	$I_{\text{trip}} = 1.8 A_{\text{RMS}}$	821 701 7								
BW068-002	$I_{\text{trip}} = 0.8 A_{\text{RMS}}$	821 692 4								
BW068-004	$I_{\text{trip}} = 1.4 A_{\text{RMS}}$	821 693 2								
<b>EMC modules</b>		Part number								
EF014-503	$I_D = 5 A_{\text{AC}}$	826 384 1								
EF030-503	$I_D = 10 A_{\text{AC}}$	826 385 X								
<b>Line chokes</b>		Part number								
ND020-013	$\Sigma I_{\text{in}} = 20 A_{\text{AC}}$	826 012 5								
<b>Input filters</b>		Part number								
NF008-443	$V_{\text{max}} = 440 V_{\text{AC}}$	825 721 3								A
NF016-443		825 719 1								B
NF008-503	$V_{\text{max}} = 550 V_{\text{AC}}$	825 831 7								
<b>Output chokes</b>		Part number								
HD001	$d = 50 \text{ mm (1.97 in)}$	813 325 5	for cable cross-sections 1.5...16 mm <sup>2</sup> (AWG16...6)							
HD002	$d = 23 \text{ mm (0.91 in)}$	813 557 6	for cable cross-sections $\leq 1.5 \text{ mm}^2$ (AWG16)							
HD003	$d = 88 \text{ mm (4.46 in)}$	813 558 4	for cable cross-sections $\geq 16 \text{ mm}^2$ (AWG6)							
<b>Output filters</b>		Part number								
HF008-503		826 029 X		A			A			
HF015-503		826 030 3		B		A	B	A		
HF022-503		826 031 1				B		B	A	
HF030-503		826 032 X							B	A
HF040-503		826 311 6								B

A in case of rated operation (100%)

B with variable torque load (125%)

MOVITRAC® 31C...-503			040	055	075	110	150	220	300	370	450	
Size			2			3			4			
<b>Braking resistors</b>			Part number									
BW047-005	$I_{trip} = 1.1 A_{RMS}$	826 268 3										
BW147	$I_{trip} = 3.5 A_{RMS}$	820 713 5										
BW247	$I_{trip} = 4.9 A_{RMS}$	820 714 3										
BW347	$I_{trip} = 7.8 A_{RMS}$	820 798 4										
BW018-015	$I_{trip} = 4.0 A_{RMS}$	821 684 3									C	
BW018-035	$I_{trip} = 8.1 A_{RMS}$	821 685 1									C	
BW018-075	$I_{trip} = 14 A_{RMS}$	821 686 X									C	
BW915	$I_{trip} = 28 A_{RMS}$	821 260 0										
BW012-025	$I_{trip} = 6.1 A_{RMS}$	821 680 0										
BW012-050	$I_{trip} = 12 A_{RMS}$	821 681 9										
BW012-100	$I_{trip} = 22 A_{RMS}$	821 682 7										
<b>EMC modules</b>			Part number									
EF075-503	$I_D = 20 A_{AC}$	826 386 8										
EF220-503	$I_D = 60 A_{AC}$	826 553 4										
EF450-503	$I_D = 115 A_{AC}$	826 554 2										
<b>Line chokes</b>			Part number									
ND020-013	$\Sigma I_{in} = 20 A_{AC}$	826 012 5				A						
ND045-013	$\Sigma I_{in} = 45 A_{AC}$	826 013 3				B		A				
ND085-013	$\Sigma I_{in} = 85 A_{AC}$	826 014 1						B		A	A	
ND1503	$\Sigma I_{in} = 150 A_{AC}$	825 548 2								B	B	
<b>Input filters</b>			Part number									
NF016-443	$V_{max} = 440 V_{AC}$	825 719 1			A							
NF025-443		825 718 3			B							
NF036-443		825 717 5										
NF050-443		825 716 7										
NF080-443		825 830 9								A		
NF110-443		826 353 1								B		
NF008-503	$V_{max} = 550 V_{AC}$	825 831 7	A									
NF016-503		825 832 5	B									
NF025-503		825 833 3					A					
NF036-503		825 834 1					B	A				
NF050-503		825 835 X						B	A			
NF080-503		826 077 X							B		A	
NF110-503		826 354 X									B	
<b>Output chokes</b>			Part number									
HD001		$d = 50 \text{ mm (1.97 in)}$	813 325 5	for cable cross-sections 1.5...16 mm <sup>2</sup> (AWG16...6)								
HD003	$d = 88 \text{ mm (4.46 in)}$	813 558 4	for cable cross-sections $\geq 16 \text{ mm}^2$ (AWG6)									
<b>Output filters</b>			Part number									
HF040-503		826 311 6	A									
HF055-503		826 312 4	B	A								
HF075-503		826 313 2		B	A							
HF023-403		825 784 1			B	A						
HF033-403		825 785 X				B	A	B/C	A/C			
HF047-403		825 786 8					B	A	B/C	C	A/C	

- A in case of rated operation (100%)
- B with variable torque load (125%)
- C connect two braking resistors or output filters in parallel!



### 2.10 MOVITRAC® 31C, size 0 with braking resistor

For 4-Q operation in Size 0 units (31C005/31C007/31C011/31C014), the braking resistors in flat-pack design BW100-003 and BW200-003 can be built into the unit. To do this, proceed as follows:

1. Disconnect inverter from the supply. Switch off mains and, if applicable, 24 V<sub>DC</sub> supply.
2. Unscrew the mounting bracket for the braking resistor from the top of the unit and pull it out (→ Fig. 9).
3. Cut the cables of the braking resistor to the required length (approx. 25 cm (10 in)) and fix on the conductor end sleeves.
4. Route the cables of the braking resistor through the rubber buffer and set the braking resistor into the mounting bracket (→ Fig. 9).
5. Put the mounting bracket with the braking resistor back into the unit and screw in firmly.
6. Unscrew the upper cover so that the X1 terminal strip of the power section is accessible.
7. Connect the cables of the braking resistor to terminals X1:8 and X1:9 as instructed in "Wiring of Power Section and Brake" (Sec. 2.8.1, Page 12).

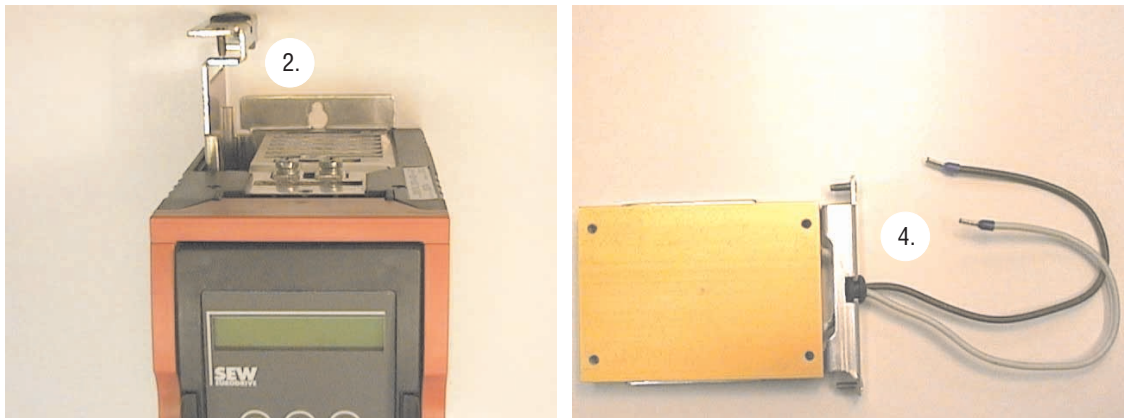

Fig. 9: Pull out mounting bracket and set the braking resistor in

01786AXX

**2.11 Connecting the RS-232 serial interface (USS21A options)**

**9-pin standard interface cable (shielded!) for RS-232 connection:**

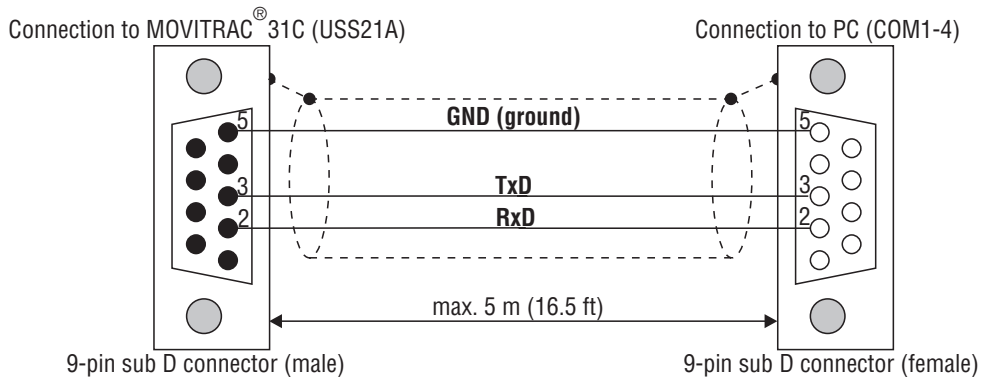

Fig. 10: Connection MOVITRAC® 31C - PC

01587AEN

**2.12 Connecting the RS-485 serial interface (USS21A option)**

**Installation instructions for the RS-485 interface:**

- Use 4-core copper shielded data cable.
- Use a twisted core pair for the signal leads.
- Use the second twisted core pair for 0V5.
- Connect the shield at both ends to PE potential with a wide area contact (electronics shielding terminals of the MOVITRAC® or proper place in the switch cabinet).

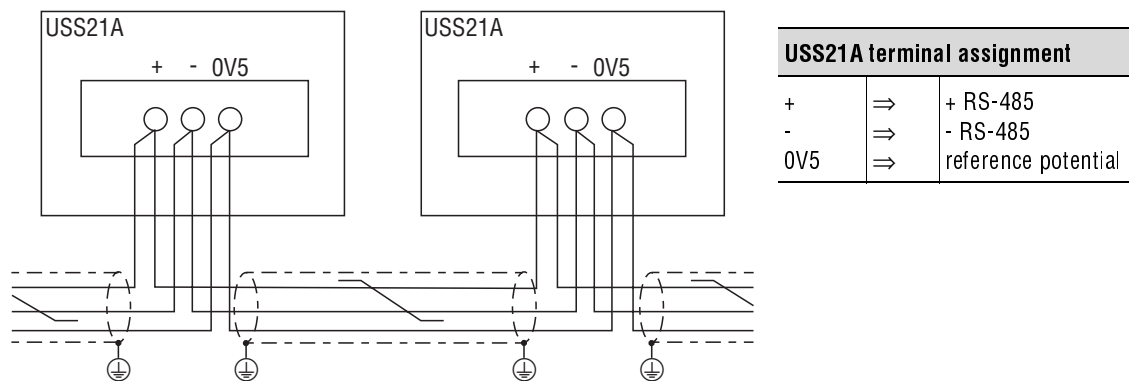

Fig. 11: USS21A RS-485 interface

00997AXX

**RS-485 interface to EIA standard:**

- max. transmission rate 9600 baud
- max. 32 nodes (every unit with the USS21A is counted as two nodes)
- max. total cable length 200 m (660 ft)
- integrated terminating resistor



### 2.13 Installation of option cards

Size 0 units (31C005/31C007/31C011/31C014) are not equipped with the X20 and X21 option slots, so no option cards can be installed in these units.

The following instructions apply to the size 1...4 units (31C008...31C450).

#### Before you begin:

- Discharge yourself with appropriate measures (earthing band, conductive shoes, etc.) before touching the option card.
- Store the option card in the original package and only unpack immediately before installation.
- Do not touch the option card more often than necessary and hold only by the edges. Do not touch components.

#### Installation of the option card:

- Disconnect inverter from the supply. Switch off mains and, if applicable, 24 V supply.
- Take off the lower protective cover.
- Remove housing (screws located under the FBG31C keypad/USS11A or UST11A interface).

For the FEA31C, FIO31C, FES31C, FFP31C, FFI31C and FFD31C options:

- Loosen system EPROM card and remove from X20 slot.
- Plug the option card into the X20 slot and fasten.
- For the FES31C, FFP31C, FFI31C and FFD31C options: remove the blank panel from the unit housing and replace with enclosed cover plate.

For the FEN31C, FPI31C and FIT31C options:

- Unscrew the electronics terminal strip X14 and remove from the X21 slot.
- Plug the option card into the X21 slot and screw on firmly.
- Replace unit house and screw on firmly.
- Replace lower protective cover.

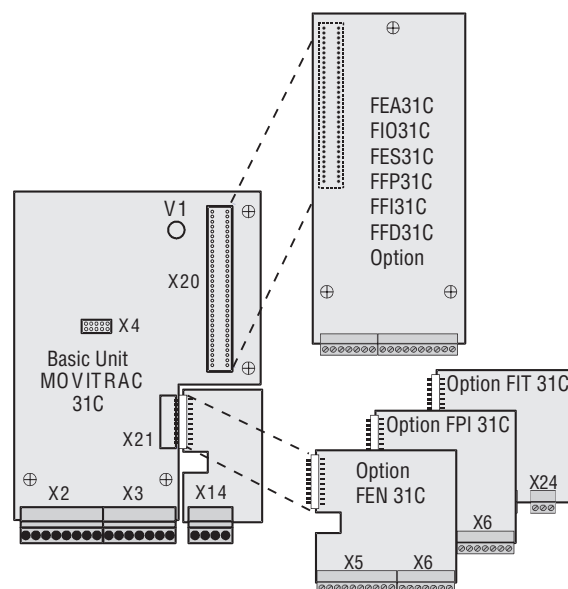

Fig. 12: Installation of option cards

01784AEN



2.14 Wiring diagram and terminal description for the FEA31C option

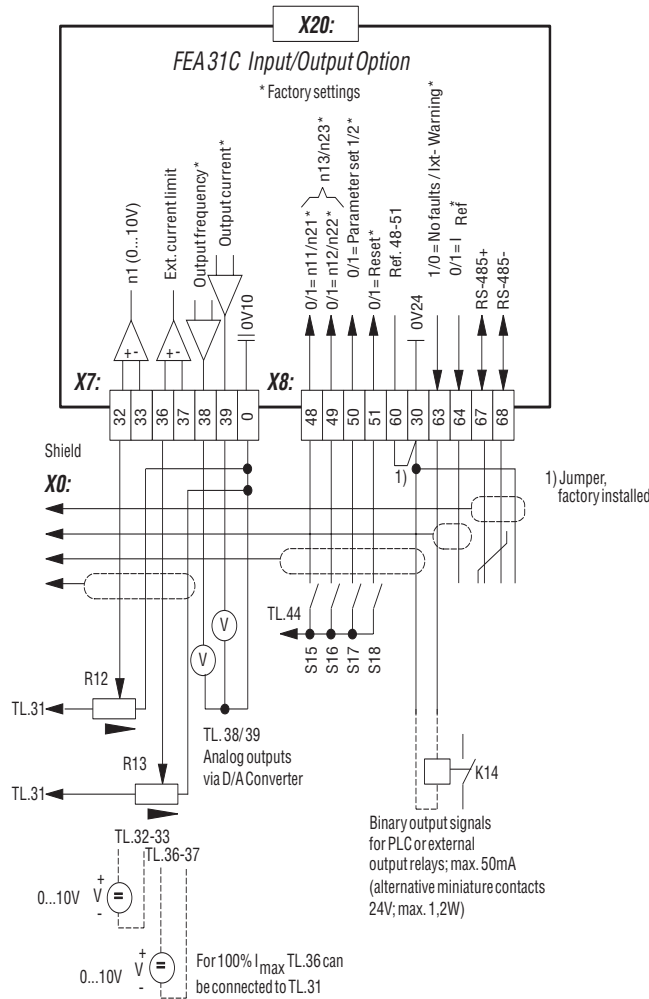

Fig. 13: FEA31C wiring diagram

00513AEN

Option	FEA31C input/output expansion	
Part number	822 297 5	
Analog differential input	X7:32/33	n1 = 0...+10V / -10V...0...+10V
External current limitation	X7:36/37	0...10V $\triangle$ 0...100% I <sub>max</sub> ( $\rightarrow$ P320)
Analog outputs	X7:38/39	Max. cable length: 10m (33 ft) / Resolution: 8 Bit / Sample time $\leq$ 10ms
Signal form		0... $\pm$ 10V, I <sub>max</sub> = 3mA
Control functions		$\rightarrow$ menu P63_
Reference terminal	X7:0	Reference potential for analog signals (0V10)
Binary inputs	X8:48/49/50/51	R <sub>i</sub> $\approx$ 3.0k $\Omega$ PLC compatible according to EN 61131-2
Signal level		I <sub>E</sub> $\approx$ 10mA Sample time: 5ms
Control functions		+13V...+30V $\triangle$ "1" opto-isolated
Reference terminal	X8:60	-3V...+5V $\triangle$ "0"
Reference terminal	X8:60	Reference for binary inputs X8:48/49/50/51
Reference terminal	X8:30	Reference potential for binary signals (0V24)
Binary outputs	X8:63/64	R <sub>i</sub> $\approx$ 100 $\Omega$ PLC compatible Response time: 5ms
Signal level		"0" = 0V "1" = +24V I <sub>max</sub> = 50mA
Control functions		$\rightarrow$ menu P61_
RS-485 interface	X8:67 68	RS-485+ EIA standard, 9600 baud, max. 32 nodes
		RS-485- Integrated terminating resistor
		Max. cable length: 200m (660ft)



2.15 Wiring Diagram and Terminal Description for the FIO31C Option

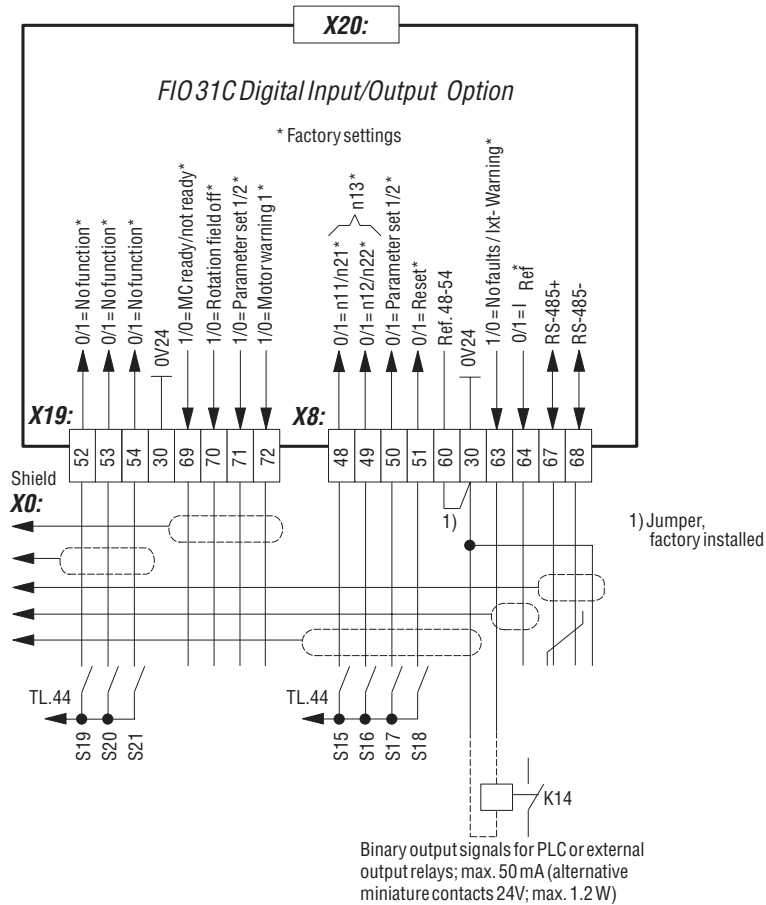

Fig. 14: FIO31C wiring diagram

00576AEN

Option	FIO31C digital input/output expansion	
Part number	822 419 6	
Binary inputs	X8:48/49/50/51 X19:52/53/54	$R_i \approx 3.0k\Omega$ PLC compatible according to EN 61131-2 $I_E \approx 10mA$ Sample time: 5ms
Signal level	+13V...+30V -3V...+5V	$\triangle$ "1"    opto-isolated $\triangle$ "0"
Control functions	→ Menü P60_	
Reference terminal	X8:60	Reference for binary inputs X8:48/49/50/51 and X19:52/53/54
Reference terminal	X8:30	Reference potential for binary signals (0V24)
Binary outputs	X19:69/70/71/72	$R_i \approx 100\Omega$ PLC compatible    Response time: 5ms
Signal level	X8:63/64	"0" = 0V    "1" = +24V $I_{max} = 50mA$
Control functions	→ menu P61_	
RS-485 interface	X8:67 68	RS-485+    EIA standard, 9600 baud, max. 32 nodes RS-485-    Integrated terminating resistor Max. cable length: 200m (660ft)

2.16 Wiring diagram and terminal description for the FEN31C/FPI31C option

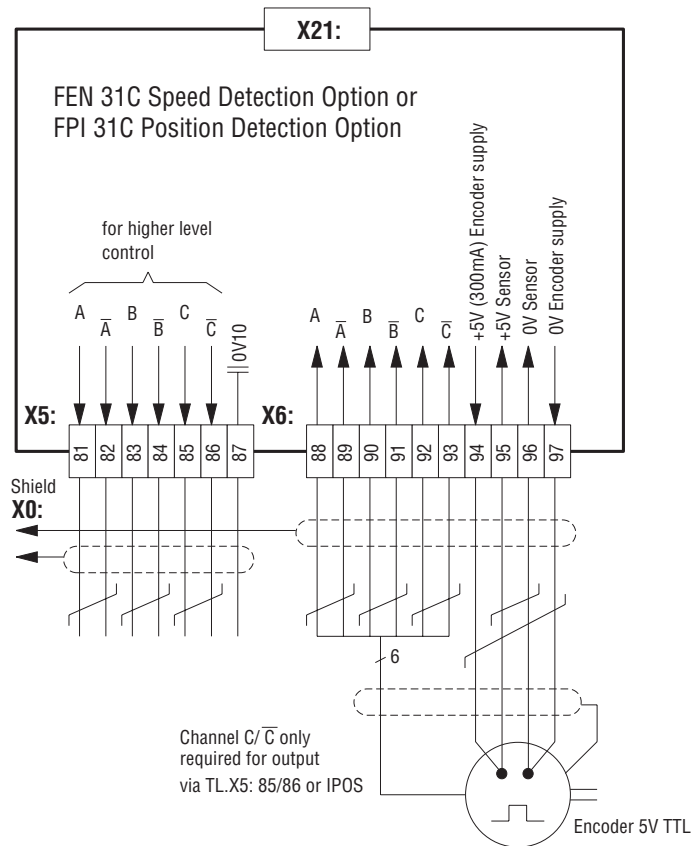

Fig. 15: FEN31C/FPI31C wiring diagram

00514AEN

Option	FEN31C speed detection / FPI31C position detection	
Part number	822 321 1 / 822 304 1	
Pulse outputs A/ $\bar{A}$ , B/ $\bar{B}$ , C/ $\bar{C}$	X5:81...X5:86	+5V, TTL level (RS-422)
Reference terminal	X5:87	Reference potential for analog signals (0V10)
Pulse inputs A/ $\bar{A}$ , B/ $\bar{B}$ , C/ $\bar{C}$ Limit speed	X6:88...X6:93	+5V, TTL level (RS-422) $f_{limit} = 200 \text{ kHz}$ 128/256/512/1024/2048 pulses/revolution (1024 preferred) 12000 $\text{min}^{-1}$ at 1024 pulses/revolution 6000 $\text{min}^{-1}$ at 2048 pulses/revolution
Encoder supply	X6:94 97	+5...8V ( $U_b / +$ ) Reference potential ( $\perp$ )
Sensor lead	X6:95 96	+5V 0V For voltage measurement and voltage drop compensation on the encoder.

**Encoder connection:**

Track sequence A → B means CW rotation of the motor facing the motor shaft.

### 2.17 Wiring diagram and terminal description for the FIT31C option

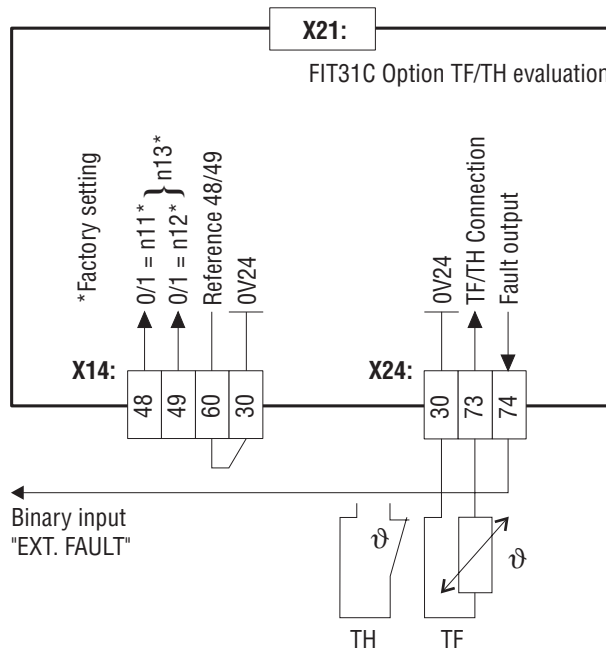

Fig. 16: FIT31C wiring diagram

01742AEN

Option	FIT31C TF/TH evaluation	
Part number	822 710 1	
Binary inputs	X14:48/49	$R_i \approx 3.0\text{k}\Omega$ PLC compatible according to EN 61131-2 $I_E \approx 10\text{mA}$ Sample time: 5ms
Signal level		+13V...+30V $\triangle$ "1" opto-isolated -3V...+5V $\triangle$ "0"
Control functions		→ Menü P60_
Reference terminal	X14:60	Reference for binary inputs X14:48/49
Reference terminal	X14:30/X24:30	Reference potential for binary signals (0V24)
TF/TH connection	X24:73	Response threshold $R_{TF} \geq 2.9\text{ k}\Omega \pm 10\%$
Binary output	X24:74	$R_i \approx 100\Omega$ PLC compatible Response time: 5ms
Signal level		"0" = 0V "1" = +24V $I_{max} = 50\text{mA}$
Control functions		"0" = motor temperature too high or TF/TH lead open circuit "1" = motor temperature within the permissible range

X24:74 is connected to a binary input which is programmed to the function "EXT. FAULT". If X24:74 = "0", the unit will trigger a rapid stop.



MOVITRAC<sup>®</sup> 31C meets the requirements for safe and reliable separation of the power and control sections in accordance with EN 50178. The FIT31C option has the same supply voltage level as the control board. If a circuit is connected to the control board of the unit which is not safety-separated, then the MOVITRAC<sup>®</sup> 31C's protection by electrical separation is no longer given.

**2.18 Connecting the incremental encoder**

Detailed information is contained in the “SEW Encoder Systems” manual which can be ordered from SEW under the number 0919 6412.

- Max. cable length (inverter - encoder):  
100 m (330 ft) at cable capacitance per unit length  $\leq 120$  nF/km (193 nF/mile)
- Core cross-section: 0.20 ... 0.5 mm<sup>2</sup> (AWG24 ... AWG20)
- Use a shielded cable with twisted-pair conductors and connect shield at both ends (to the electronics shield clamp and to the encoder connector).
- Route the encoder cable separately from the power cables.
- Permissible number of increments: 256, 512, 1024, 2048 (preferably 1024)

**Apply the shield of the encoder cable over a wide contact surface:**

- on the inverter
- on the encoder



01937AXX

Fig. 17: Apply the shield to the electronics shield clamp of the inverter.



01948AXX

Fig. 18: Apply the shield to the PG screw of the encoder.

For operation with MOVITRAC<sup>®</sup> 31C frequency inverters, SEW recommends using the ES1T, ES2T or EV1T incremental encoders (TTL encoder), previously the IG11 / IG5 encoders. Connect the encoder as follows:

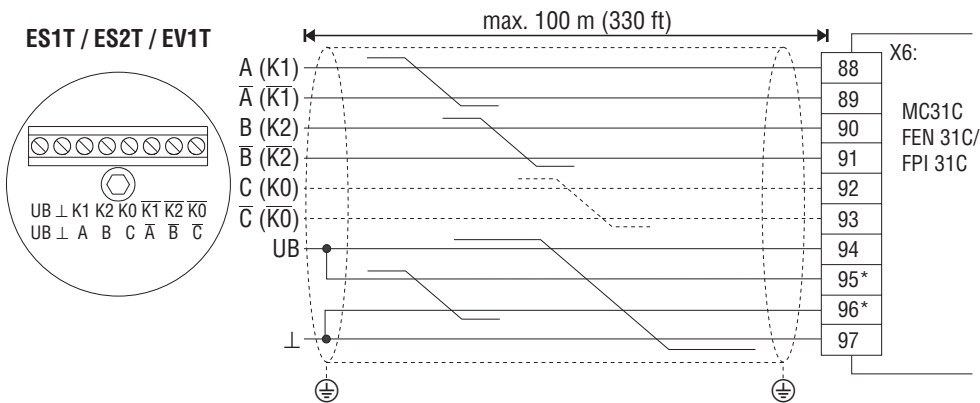

\* Connect the sensor leads of the encoder to UB and  $\perp$ , do not jumper on the inverter!

01585BXX

Fig. 19: Connection of the TTL encoder ES1T, ES2T or EV1T to the MOVITRAC<sup>®</sup> 31C

The K0 (C) and  $\overline{K0}$  ( $\overline{C}$ ) tracks are required only for the positioning control (FPI31C option). They are not needed for speed control (FRN31C or FEN31C option) or for synchronous operation (FRS31C option).



### 3 Startup



**Observe the following safety instructions (→ Sec. 1, page 4) during startup!**

The prerequisite for a successful startup is the correct project planning of the drive. Detailed instructions for project planning and the explanation of the parameters are contained in the MOVITRAC® 31C catalog (order no.: 0922 9116).

#### 3.1 Preliminary work and aids

##### Preliminary work:

- Check installation (→ Sec. 2, Installation).
- Prevent unintentional start-up of the motor with appropriate measures (e.g. removing the electronics terminal strip X3). Depending on the application, additional measures must be taken to ensure that there is no danger to persons or equipment.
- When startup with FBG31C keypad:  
Plug FBG31C keypad into X4 slot.
- When startup with PC and MC\_SHELL:  
Plug USS11A option into X4 slot and connect with the PC using an interface cable (RS-232). For this the MOVITRAC® 31C and PC must be voltage-free, otherwise undefined states can occur. Switch on both units and, if not yet available, install and start MC\_SHELL on the PC.
- Switch on mains supply and, if applicable, 24V supply. LED (V1) display is yellow.  
When using the FBG31C keypad, the following message is displayed for approx. 5 seconds:

SELFTEST

01593AXX

- Correct presetting of the parameters (e.g. factory setting). The factory setting of the inverter provides an activated short menu on the FBG31C keypad which is indicated by the “P” after the parameter number.
- Check the programmed terminal assignment (→ P60\_ / P61\_).

For programming IPOS, MC\_SHELL is required. The IPOS parameters cannot be edited and changed with the FBG31C keypad. The IPOS program is stored on the FBG31C when it is saved and when copying the parameter set onto another MOVITRAC® 31C it is also copied.



## 3.2 Short-cut startup with the FBG31C keypad

### 3.2.1 Functions of the FBG31C keypad for startup

Detailed information → Sec. 4.1.2

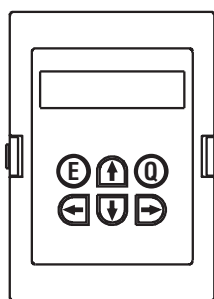

01406AXX

- ↑ -key: Next menu point or, in editing mode, changes value (greater).
- ↓ -key: Previous menu point or, in editing mode, changes value (smaller).
- -key: Either one menu level down or changes to editing mode of the menu point.
- ← -key: One menu level up or exits editing mode of the menu point.
- Q -key: Returns to basic display.
- E -key: Reset in case of fault.

### 3.2.2 Selecting a language on the FBG31C keypad with the short menu

- The default language displayed is German.

KEINE FREIGABE	01595ADE
-------------------	----------

- Press the ↓-key three times.  
P850 (LANGUAGE) is then displayed.

850/ DEUTSCH SPRACHE	01770ADE
-------------------------	----------

- Press the →-key to activate the editing mode. Use the ↓- or ↑-key to select the language and exit the editing mode by pressing the ←-key.

850/ ENGLISH _ LANGUAGE	01771AEN
----------------------------	----------

- Press the Q-key to return to the default display.

### 3.2.3 Selecting a language on the FBG31C keypad with the detailed parameter menu

- The default language displayed is German.

KEINE FREIGABE	01595ADE
-------------------	----------

- Press the ↓-key once.  
The 8.. parameter group is then displayed.

8.. SONDER- FUNKTIONEN	01767ADE
---------------------------	----------

- Press the →-key once and the ↑-key five times.  
The 85. parameter group (LANGUAGE SWITCHING) is then displayed.

85. SPRACHEN- UMSCHALTUNG	01768ADE
------------------------------	----------

- Press the →-key to select P850 (LANGUAGE) and press the →-key again to activate the editing mode. Use the ↓- or ↑-key to select the language and exit the editing mode by pressing the ←-key.

850 ENGLISH _ LANGUAGE	01769AEN
---------------------------	----------

- Press the Q-key to return to the default display.

### 3.2.4 Short-cut startup procedure

- "0"-signal on terminal X3:43 ("Enable/rapid stop"), e.g. by disconnecting electronics terminal strip X3.

NO ENABLE
-----------

01595AEN

- Set FMIN1 (P200) = 5 Hz and FBASE1 (P201) and FMAX1 (P202) as per the motor nameplate data.

200/	5.00HZ
FMIN1	

01597AXX

- Return to default display with "Q" and start the drive with a "1" signal on X2:41 ("CW/stop") or X3:42 ("CCW/stop") and a "1" signal on X3:43 ("Enable/rapid stop"). The drive runs at a frequency of FMIN1 = 5 Hz.

FREQ.	5.00 Hz
CURRT	73%

01772AEN

**Important:** The current display relates to the inverter rated current, not to the motor rated current. If using a motor with rated motor power < recommended motor power rating of the inverter, the indicated inverter current must be converted to motor current.

**Example:** Recommended motor power rating inverter = 3 kW, rated motor power = 1.5 kW  
→ Display "CURRENT 50%"  $\triangle$  100% motor rated current

It must also be noted that in this case "Motor size-up" (P328/P348 = "YES") causes excessive Boost and  $I \times R$ , such that excessive motor current is induced.

- Check direction of rotation of the drive (correct by switching off and exchanging motor phases).
- If the drive is running properly, the frequency setpoint can be increased until the required drive frequency is induced.

FREQ.	30.00 Hz
CURRT	78%

01773AEN

- Set the ramp generators, e.g. T11 RAMPE UP (P120), and the frequency characteristics (e.g. FMIN1) as per the project data.

120/T11	1.00 s
RAMP UP	

01598AEN



**Important:** If N2 SIGNAL TL.34/35 (P110) is programmed to -10...10V, the fixed setpoints (P160...P162/P170...P172) cannot be selected.

#### The function "Motor size-up" (P328/P348):

Can be used to adjust the values for BOOST and  $I \times R$  automatically (P328/P348 = YES). This is useful for single-motor operation with a matched motor ( $P_{Mot}$  = recommended motor power rating of the inverter). The values may be changed by manual adjustment. When the "Motor size-up" function is switched on (P328/P348 = YES), BOOST and  $I \times R$  will be adjusted to the changed operating conditions (e.g. warmed up motor) at every enable.

#### Manual setting of BOOST and $I \times R$ (P328/P348 = NO):

The values are stored in the non-volatile memory. Set BOOST (P321/P341) and  $I \times R$  (P322/P342) with the cold motor. If the setting is carried out with the warm motor the drive may be overcompensated when it is later switched on in cold state, i.e. it may fail to start. In this case, BOOST and  $I \times R$  must be reduced as far as is necessary until the drive starts.

#### Recommendation:

- Enter parameter settings, which are not identical with the factory setting, in the parameter list (→ sec. 3.5).
- For information about the starting of the motor, please refer to the notes in sec. 3.3, page 29.

### 3.3 Starting the motor

#### Operation with analog setpoint signal (unipolar, selection of the direction of rotation via terminals):

The following table shows which signals must be present with factory setting (P110 = 0...10 V) at the terminals X2 and X3 so that the drive is operated with an analog setpoint signal.

X2:41 CW/stop	X3:42 CCW/stop	X3:43 Enable/rapid stop	X2:34 n2	Function
X	X	"0"	X	No enable
"0"	"0"	"1"	X	Stop
"1"	"0"	"1"	5 V	CW operation with 25 Hz
"1"	"0"	"1"	10 V	CW operation with 50 Hz
"0"	"1"	"1"	5 V	CCW operation with 25 Hz
"0"	"1"	"1"	10 V	CCW operation with 50 Hz

The following travel diagram shows exemplarily how the motor is started with an analog setpoint by applying signals to the terminals X2/X3. The binary output X3:61 ("/Brake") is used to switch the brake contactor K12.

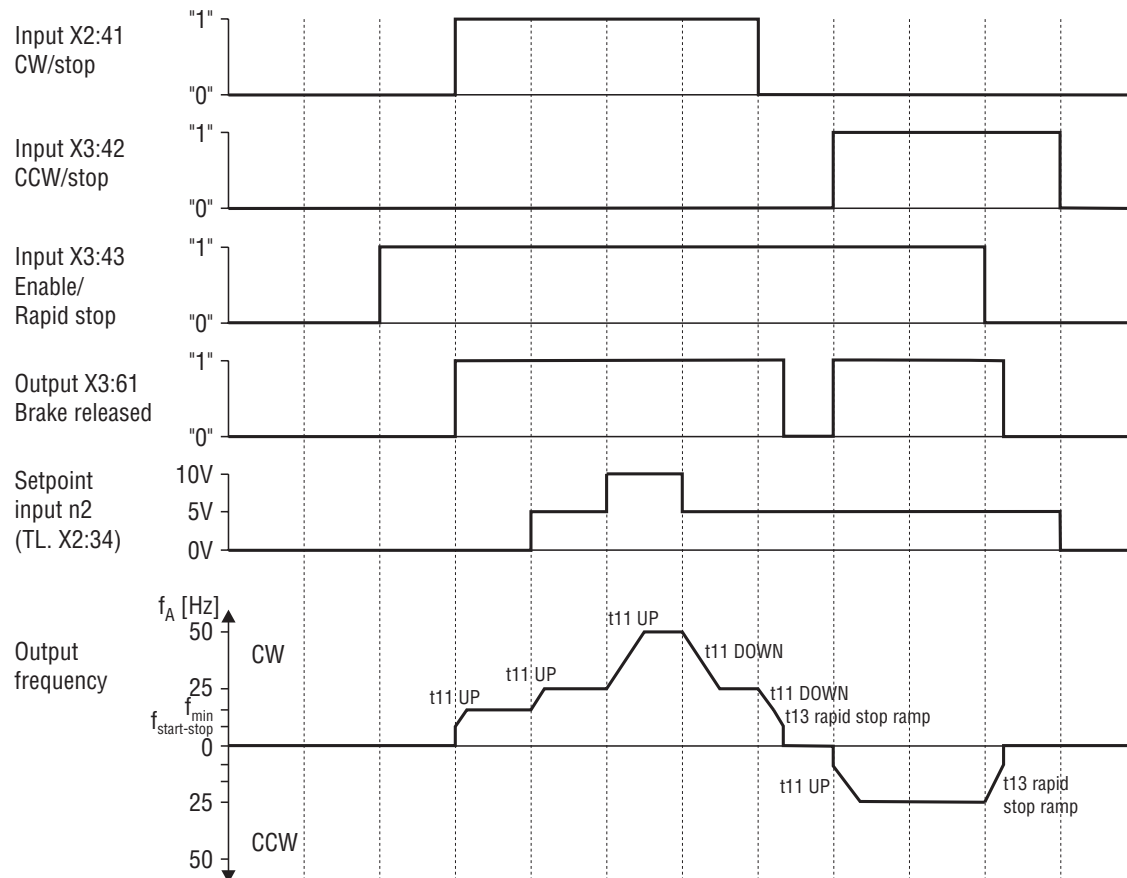

01599AEN

Fig. 20: Travel diagram with analog setpoints

### Operation with fixed setpoints (selection of the direction of rotation via terminals):

The following table shows which signals must be present with factory setting (P110 = 0...10 V) and installed FEA31C option at the terminals X2/X3/X8 so that the drive is operated with fixed setpoints.

X2:41 CW/stop	X3:42 CCW/stop	X3:43 Enable/rapid stop	X8:48 n11/n21	X8:49 n12/n22	Function
X	X	"0"	X	X	No enable
"0"	"0"	"1"	X	X	Stop
"1"	"0"	"1"	"1"	"0"	CW operation with n11
"1"	"0"	"1"	"0"	"1"	CW operation with n12
"1"	"0"	"1"	"1"	"1"	CCW operation with n13
"0"	"1"	"1"	"1"	"0"	CCW operation with n11

The following travel diagram shows exemplarily how the motor is started with fixed setpoints by applying signals to the terminals X2/X3/X8. The binary output X3:61 ("Brake") is used to switch the brake contactor K12.

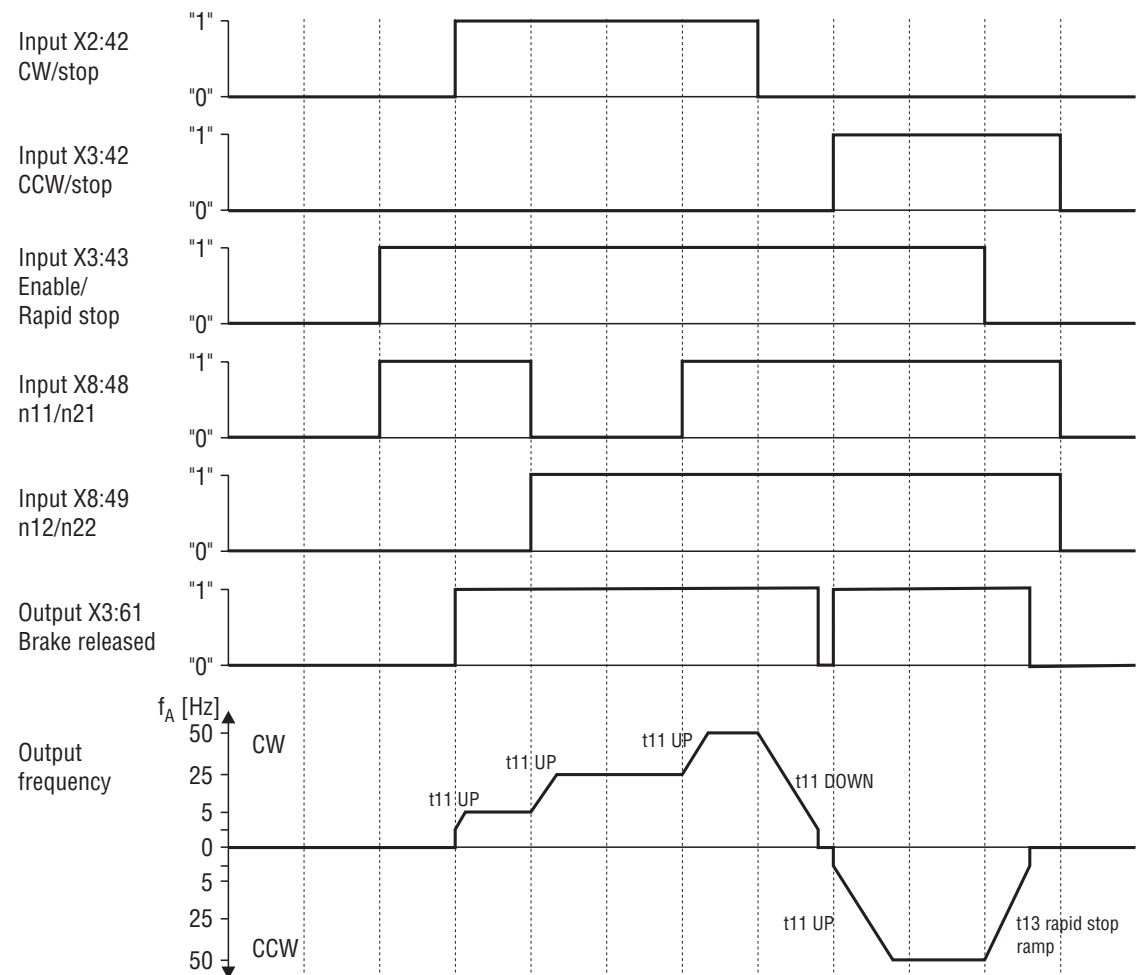

01602AEN

Fig. 21: Travel diagram with fixed setpoints

**Manual operation:**

The “Manual operation” function allows the inverter to be operated manually via the FBG 31C keypad, without external commands over the binary inputs. The input commands are ineffective during manual operation.

The direction of rotation is not determined by the "CW/Stop" or the "CCW/Stop" input commands, but rather by selecting the direction with the keypad (→ Fig. 22).

Manual operation remains in effect after power-down and power-up, however, the inverter is not enabled after power up. A directional command with the [→] or [←] keys results in an enable and start at  $f_{min}$  in the chosen direction of rotation. Speed is increased and reduced with the [↑] or [↓] keys. The rate of change is 150 rpm per second.

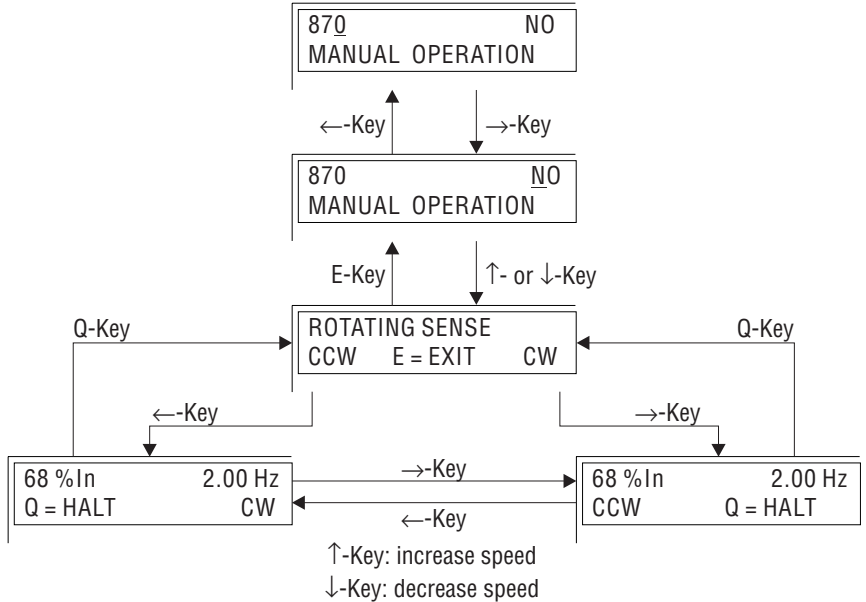

Fig. 22: Manual operation with FBG31C

01798AEN

### 3.4 Startup examples

#### 3.4.1 Notes and presettings for the following examples

##### Notes:

- The examples refer to the parameter settings as per the factory setting and parameter set 1.
- The terminal designations and functions refer to the wiring diagram for the basic unit (→ Sec. 2.7, page 11).
- Rated motor power  $P_{Mot}$  = recommended motor power rating of the inverter.
- Setpoint n2 (TL. 34/35) is set to V signal unipolar (P110 = 0...10V) by factory.  
Alternate settings:
  - V signal bipolar (P110 = -10...+10V)
  - I signal 0...20 mA (P110 = 0...20mA and S1 switch on I signal = left)
  - I signal 4...20mA (P110 = 4...20mA and S1 switch on I signal = left)

##### Presettings:

- “0”-signal on all binary inputs and setpoint inputs.
- Set P802 “Short menu” = OFF, the complete parameter menu is available.
- Set the ramp generator time P120 “t11 Ramp up” and P121 “t11 Ramp down” to the project data values. Set P120 and P121 to 5...1 s without special requirements (start with the higher value).
- Operation with a matched motor ( $P_{Mot}$  = recommended motor power rating of the inverter)  
Set P320 “ $I_{max1}$ ” = 150% (factory setting).
- Setting of P324 “Pole pair no. 1” of the connected motor:  
P324 = 1 for 2-pole motor  
P324 = 2 for 4-pole motor (factory setting) etc.  
This serves to indicate the correct speed in P004 “Speed”.
- Check P329 “Motor voltage 1” (nameplate of the motor) and set it if necessary.
- Set P328 “Motor size-up 1” = YES (factory setting) when using a matched motor.  
If  $P_{Mot} <$  recommended motor power rating of the inverter: set P328 = NO and P321 “BOOST” and P322 “ $I \times R$ ” must be adjusted manually.
- **Checking the operating behavior:** After adjustment, the motor should have a no-load current of about 70...80% when cold. If the application requires a high breakaway torque, then a no-load current of 100% is also permissible for a short time. If the no-load current is too low or the motor is overcompensated, then this can be corrected with the P321 “BOOST 1” and P322 “ $I \times R1$ ” settings.

### 3.4.2 Example values for BOOST and I×R

If you use an adjusted motor ( $P_{Mot}$  = recommended motor rating of inverter  $\pm 1$  type jump), you can automatically determine the values for BOOST 1 (P322) and I×R 1 (P322) with P328 "Measure out motor 1" = YES (factory setting). The function can result in excessive BOOST and I×R settings due to interferences, such as too small motor line cross sections or unstable terminal contacts. The result may be that the inverter will quickly reach the current limit value during acceleration and the drive not reach the desired speed.

The following tables are an example for those BOOST- und I×R values determined by the "measure out motor" function when connecting a 4-pole SEW AC motor (IEC and NEMA version). Please note that these are merely guidelines. The BOOST and I×R values are subject to different influences, e.g. motor lines and motor windings temperatures.

#### Prerequisites:

- Motor line, 100 m (330 ft) long
- Motor lines are multi-core copper wires with PVC insulation
- Motor lines and motor windings temperature is approximately 20°C. IF the motor windings temperature is approximately 100°C, the BOOST and I×R values listed below must be increased by about 30%.

#### Data for IEC motors, motor voltage (P329) = 400 V

Star connection,  $f_{base}$  (P201, P211) = 50 Hz:

Motor type	MOVITRAC® 31C...-503	Cross section of motor line [mm <sup>2</sup> ]	BOOST [%]	I×R [%]
DT71D4	31C005	1.5	101	76
DT80K4	31C005	1.5	56	42
DT80N4	31C007 / 31C008	1.5	50	38
DT90S4	31C011	1.5	49	37
DT90L4	31C014 / 31C015	1.5	42	31
DT100LS4	31C022	1.5	46	35
DT100L4	31C030	1.5	48	29
DV112M4	31C040	1.5	54	40
DV132S4	31C055	1.5	54	30
DV132M4	31C075	2.5	44	25
DV160M4	31C110	6	34	19
DV160L4	31C150	6	36	20
DV180L4	31C220	10	30	17
DV200L4	31C300	16	26	14
DV225S4	31C370	25	23	13
DV225M4	31C450	35	18	10

Star connection,  $f_{base}$  (P201, P211) = 87 Hz:

Motor type	MOVITRAC® 31C...-503	Cross section of motor line [mm <sup>2</sup> ]	BOOST [%]	I×R [%]
DT71D4	31C005	1.5	37	28
DT80K4	31C007 / 31C008	1.5	27	20
DT80N4	31C011	1.5	26	20
DT90S4	31C014 / 31C015	1.5	26	20
DT90L4	31C022	1.5	28	21
DT100LS4	31C030	1.5	33	20
DT100L4	31C040	1.5	40	30
DV112M4	31C055	1.5	43	24
DV132S4	31C075	2.5	35	20
DV132ML4	31C110	6	23	13
DV160M4	31C150	6	30	17
DV180M4	31C220	10	24	13
DV180L4	31C300	16	20	11
DV200L4	31C370	25	16	9
DV225S4	31C450	35	15	8

Data for NEMA motors, motor voltage (P329) = 460 V

Star connection,  $f_{base}$  (P201, P211) = 60 Hz:

Motor type	MOVITRAC® 31C...-503	Cross section of motor line [AWG]	BOOST [%]	I×R [%]
DT71D4	31C005	14	87	65
DT80K4	31C005	14	48	36
DT80N4	31C007 / 31C008	14	42	32
DT90S4	31C011	14	39	29
DT90L4	31C014 / 31C015	14	34	26
DT100LS4	31C022	14	37	28
DT100L4	31C030	14	37	22
DV112M4	31C040	12	35	26
DV132S4	31C055	10	31	17
DV132M4	31C075	10	29	16
DV160M4	31C110	8	26	14
DV160L4	31C150	6	21	12
DV180L4	31C220	4	19	11
DV200L4	31C300	3	22	12
DV225S4	31C370	2	20	11
DV225M4	31C450	2	22	12



Double star connection,  $f_{base}$  (P201, P211) = 120 Hz:

Motor type	MOVITRAC® 31C...-503	Cross section of motor line [AWG]	BOOST [%]	I×R [%]
DT71D4	31C005	14	24	18
DT80K4	31C007 / 31C008	14	17	13
DT80N4	31C011	14	17	13
DT90S4	31C014 / 31C015	14	16	12
DT90L4	31C022	14	18	14
DT100LS4	31C030	14	21	13
DT100L4	31C040	12	20	15
DV112M4	31C055	10	16	9
DV132S4	31C075	10	18	10
DV132ML4	31C110	8	15	9
DV160M4	31C150	6	14	8
DV180M4	31C220	4	12	7
DV180L4	31C300	3	12	6
DV200L4	31C370	2	12	7
DV225S4	31C450	2	13	7



### 3.4.3 Travel drive, group drive, pump or fan drive

The notes and presettings of sec. 3.4.1 must be observed!

1. Set P200 " $f_{min1}$ " = 2...6 Hz.
2. Set P201 " $f_{base1}$ " and P202 " $f_{max1}$ " as per the project data.
3. Operation with a matched motor: set P328 "Motor size-up 1" = YES and continue at point 12. If  $P_{Mot} <$  recommended motor power rating of the inverter and in case of group drives with common load: set P328 = NO and continue at point 4. Set BOOST (P321/P341) and  $I \times R$  (P322/P342) with the cold motor.
4. Set P321 "BOOST 1" = 0%.  
Set P322 " $I \times R$ " = 0%.  
Set P323 "Slip 1" = 0 Hz.  
Select P321 "BOOST 1" again.
5. Enable the drive with a "1" signal on TL. 43 "Enable/rapid stop" and "1"-signal on TL. 41 "CW/stop" or TL. 42 "CCW/stop". Check direction of rotation of the drive (correct by switching off and exchanging motor phases).  
→ The inverter produces an output of  $f_{min1}$ , the drive remains at rest or runs very slowly.
6. Increase P321 "BOOST 1", until the drive accelerates to  $f_{min}$  and 80%  $I_R$  is flowing.
7. Increase P322 " $I \times R$ ", until  $I_{max}$  is flowing, i.e. 150%  $I_R$  is displayed.
8. Set P321 "BOOST1" to zero.
9. Reduce P322 " $I \times R$ " until the current gets out of the current limit ( $\leq 150\% I_n$ ).
10. Increase P321 "BOOST 1" again, until the current is 80%  $I_R$ .
11. Remove the enable with a "0" signal on TL. 43 "Enable/rapid stop" and "0"-signal on TL. 41 "CW/stop" or TL. 42 "CCW/stop".
12. Set P200 " $f_{min1}$ " to the project data value.
13. Set P323 "Slip 1" to the rated slip  $s_N$  of the motor.

Number of pole pairs	Rated motor speed [rpm]									
	Rated motor frequency 50 Hz					Rated motor frequency 60 Hz				
1 (2-pole)	2700	2760	2820	2880	2940	3300	3360	3420	3480	3540
2 (4-pole)	1350	1380	1410	1440	1470	1650	1680	1710	1740	1770
Slip setting $s_N$	5 Hz	4 Hz	3 Hz	2 Hz	1 Hz	5 Hz	4 Hz	3 Hz	2 Hz	1 Hz

14. Connect external setpoint inputs (e.g. setpoint potentiometers) to TL. 32/33 "n1" (only with FEA31C) or TL. 34/35 "n2" (basic unit).
15. Start up the motor (→ sec. 3.3).

#### Note:

Set P328 "Motor size-up 1" = NO in case of group drives without common load. The steps 7 through 10 are omitted. Set only the BOOST parameter,  $I \times R$  stays at zero.

#### For pumps and fans (in 1Q-mode):

Set long Ramp Up and Ramp Down ( $t_{11}$ ,  $t_{21}$ ) times ( $\approx$  time required for motor to coast to a stand-still) and bridge TL. X3:43 ("Enable/rapid stop") with TL. X2:44 (+24V) or program TL. X3:43 to "No function".

### 3.4.4 Hoist drives with and without counterweight

The notes and presettings of sec. 3.4.1 must be observed!



1. The hoist should be in the lowest position.
2. Allocation:  
 “1”-signal on TL. 41 “CW/stop” = hoist movement UP  
 “1”-signal on TL. 42 “CCW/stop” = hoist movement DOWN
3. Hoist with counterweight: P710 “Hoist function 1” = NO  
 Hoist without counterweight: P710 “Hoist function 1” = YES
4. Set P326 “Premagnetization time 1” = 200 ms.  
**Caution:** If the premagnetization time is too short the hoist could sag during starting.
5. Set P200 “ $f_{min}1$ ” = 10 Hz.
6. Set P201 “ $f_{base}1$ ” = 50 Hz and P202 “ $f_{max}1$ ” = 70 Hz.
7. Set P260 “Set 1 START/STOP freq.” to  $1.5 \times s_N$  (rated slip of the motor).



Number of pole pairs	Rated motor speed [rpm]									
	Rated motor frequency 50 Hz					Rated motor frequency 60 Hz				
1 (2-pole)	2700	2760	2820	2880	2940	3300	3360	3420	3480	3540
2 (4-pole)	1350	1380	1410	1440	1470	1650	1680	1710	1740	1770
Slip setting $s_N$	5 Hz	4 Hz	3 Hz	2 Hz	1 Hz	5 Hz	4 Hz	3 Hz	2 Hz	1 Hz

8. Operation with a matched motor: set P328 “Motor size-up 1” = YES and continue at point 13.  
 If  $P_{Mot} < \text{recomm. motor power rating of the inverter}$ : set P328 = NO and continue at point 9.  
 Set BOOST (P321/P341) and  $I \times R$  (P322/P342) with the cold motor.
9. Set P321 “BOOST 1” = 100%.  
 Set P322 “ $I \times R$ ” = 0%.  
 Set P323 “Slip 1” = 0 Hz.  
 Select P321 “BOOST 1” again.
10. Enable the drive with a “1” signal on TL. 43 “Enable/rapid stop” and a “1” signal on TL. 41 “CW/stop” or TL. 42 “CCW/stop”. Check direction of rotation of the drive (correct by switching off and exchanging motor phases).  
 → The inverter operates at the current limit ( $I_N = 140...150\%$ ).  
 If the fault signal “OVERCURRENT” appears, reduce the BOOST and re-enable the drive.
11. Reduce P321 “BOOST 1”, until the drive accelerates to  $f_{min}$  and  $<100\% I_N$  is displayed.
12. Remove the enable with “0”-signal on TL. 43 and set P322 “ $I \times R$ ” to 75% of the BOOST value.  
 Example: determined BOOST value = 40 % → set  $I \times R = 30\%$ .
13. Set P200 “ $f_{min}1$ ” to the project data value but more than 6 Hz.
14. Set P323 “Slip 1” to the rated slip  $s_N$  of the motor.
15. Set P510 “Speed monitoring 1” and P520 “Regen. monitoring 1” = YES.
16. Connect external setpoint inputs (e.g. setpoint potentiometers) to TL. 32/33 “n1” (only with FEA31C) or TL. 34/35 “n2” (basic unit).
17. Start up the motor (→ sec. 3.3) and check the hoisting and lowering functions. If the drive does not come up to speed (display CURRENT 150%), reduce  $I \times R$  a bit. At low speeds the current should be  $< 150\%$ .



### 3.4.5 Speed controller FRN31C / FEN31C

The notes and presettings of sec. 3.4.1 must be observed!

1. Check the encoder connection (→ sec. 2.18).
2. Startup without speed control (P770 = V/f mode) as described in sec. 3.4.3.
3. Check direction of motor rotation; important for the assignment of the encoder tracks.  
“1” signal on TL. 41 and 43 “CW/stop”: Looking onto B side of the motor → CCW rotation  
(A side = shaft end, B side = fan) Looking onto A side of the motor → CW rotation  
If the sense of direction is wrong, exchange motor phases.
4. Set P260 “Set 1 START/STOP freq.” to the project data, e.g. 0.5 Hz.
5. Set P323 “Slip 1” to the rated slip  $s_N$  of the motor.

Number of pole pairs	Rated motor speed [rpm]									
	Rated motor frequency 50 Hz					Rated motor frequency 60 Hz				
1 (2-pole)	2700	2760	2820	2880	2940	3300	3360	3420	3480	3540
2 (4-pole)	1350	1380	1410	1440	1470	1650	1680	1710	1740	1770
Slip setting $s_N$	5 Hz	4 Hz	3 Hz	2 Hz	1 Hz	5 Hz	4 Hz	3 Hz	2 Hz	1 Hz



**Important:** It is imperative that P323 is set to the correct value, in all cases  $\neq 0$ .

6. Setting of P324 “Pole pair no. 1” of the connected motor:  
P324 = 1 for 2-pole motor  
P324 = 2 for 4-pole motor (factory setting) etc.
7. Set P510 “Speed monitoring 1” and P520 “Regen. monitoring 1” = YES.
8. Set P511 and P521 “Response time 1”. Consider acceleration and overload time.
9. Set P770 “Operation mode” = SPEED CONTROL.
10. Set P773 “Increments” (factory setting = 1024).
11. Set P774 “s×R” = YES. The motor is supplied with current for 500 ms and P321 “BOOST1” and P322 “l×R” are set. If P774 = NO remains set, then P322 must be set manually.
12. Start up the motor (→ sec. 3.3).



**Caution:**

If the value of “Increments” (P773) is too small and/or the number of pole pairs (P324) is too high, the drive will accelerate without control up to  $f_{max}$  when enabled (TL. 43 = “1”). A fault is only recognized when motor mode speed monitoring 1 (P510 = YES) is enabled **and** regenerative mode speed monitoring (P520 = YES). Then a rapid stop is triggered. If P510 and P520 are not activated, shut off the drive with Mains Off. If a binary input is programmed to “/Controller inhibit”, the drive can also be shut off with a “0” signal on the binary input.

**Optimize the speed controller:**

1. Set P120 “t11 Ramp up” and P121 “t11 Ramp down” to permissible minimum value and start the drive.
2. Set P772 “Controller time constant” > 200 ms and increase P771 “P gain” until the drive begins to oscillate.
3. Reduce P771 until the drive just stops oscillating. Operate through the speed range.
4. Decrease P772 in steps. Input a setpoint step change; correct setting is with only 1 or 2 overshoots.
5. P777 “P precontrol” prevents excessive overshoots. P777 = 0 means P precontrol = OFF. The higher P777 is set, the higher P778 “Setpoint filter” should also be set.

### 3.5 Complete parameter list

All parameters available with the short menu (→ Sec. 4.1.3) are marked with a “/”.  
The short menu will be switched on/off with P802/.

● = not available on size 0 (MC31C005/007/011/014)

Par.	Name	Value range	Par.	Name	Value range
<b>DISPLAY VALUES</b>			<b>DISPLAY VALUES</b>		
<b>Basic display</b>			<b>06_ Fault memory</b>		
/	Frequency / current	0...400 Hz / 0...200%	060/	ERROR t-0	Submenu for faults 0...4:
<b>00_</b>	<b>Process values</b>		061	ERROR t-1	Meas. values at time: V <sub>DC link</sub> /heat sink temp./ I <sub>app</sub> /I <sub>x</sub> t/terminals/ par. set/motor utilization
000	Current / frequency	0...200%/0...400 Hz	062	ERROR t-2	
001	Temperature	-20...+100°C	063	ERROR t-3	
002	Actual parameter set	1/2	064	ERROR t-4	
003●	External I limit TL.36/37	0...100%	<b>07_● Fieldbus monitor (only with FFP, FFI or FFD option)</b>		
004	Speed	0...9999 rpm	070●	PD configuration	1PD+par./1PD 2PD+par./2PD 3PD+par./3PD
<b>01_ Voltages</b>			071●	Fieldbus type	PROFIBUS/INTERBUS/ DeviceNet
010	Voltage DC link	0...1000 V	072●	Fieldbus baud rate	0...1500 kbaud
011	V motor and frequency	0...1000 V / 0...400 Hz	073●	Fieldbus address	0...255
<b>02_ Currents / power</b>			074●	PO1 setpoint	0000...FFFF <sub>hex</sub>
020	I apparent	0...200%	075●	PI1 actual value	0000...FFFF <sub>hex</sub>
021/	Utilization	0...125%	076●	PO2 setpoint	0000...FFFF <sub>hex</sub>
022/	Motor utilization 1	0...200%	077●	PI2 actual value	0000...FFFF <sub>hex</sub>
023●	Motor utilization 2	0...200%	078●	PO3 setpoint	0000...FFFF <sub>hex</sub>
<b>03_ Status binary inputs</b>			079●	PI3 actual value	0000...FFFF <sub>hex</sub>
030/	TL. 41/42/43/47	0/1			
031/	TL. 48/49 TL. 50/51 (with FEA/FIO)	0/1			
032	TL. 52/53/54 (with FIO)	0/1			
<b>04_ Status binary outputs</b>					
040	TL. 61/62 TL. 63/64 (with FEA/FIO)	0/1			
043	TL. 69/70/71/72 (with FIO)	0/1			
<b>05_● Options</b>					
050●	Option 1 (X20)	None/FEA/FFP/FFI/FES/ FIO			
051●	Option 2 (X21)	None/Option card 2/ FEN/FPI/FIT			

Par.	Name	Setting range Factory setting	After start-up	Par.	Name	Setting range Factory setting	After start-up
	Switchable par. Parameter set 1				Parameter set 2		
<b>1_ SETPOINTS / RAMP GENERATORS</b>							
<b>10_ Setpoint n1 terminal 32/33 (only with FEA)</b>							
100•	n1 characteristic	Gain/offset					
101•	n1 gain factor	0.1...1...10					
102•	n1 offset factor	0.1...1...9					
<b>11_ Setpoint n2 terminal 34/35 (basic unit)</b>							
110/	n2 signal TL. 34/35 (S1 to be noted!)	0...10 V / -10...10V / 0...20mA / 4...20mA					
111	Setpoint offset	-500...0...500 mV					
<b>12_ 1st ramp generator</b>							
120/	t11 ramp up	0.0...1...2000 s		123•	t21 ramp up	0.0...1...2000 s	
121/	t11 ramp down	0.0...1...2000 s		124•	t21 ramp down	0.0...1...2000 s	
122	t11 S-pattern	0/1/2/3		125•	t21 S-pattern	0/1/2/3	
<b>13_ 2nd ramp generator</b>							
130/	t12 ramp up = down	0.0...5...2000 s		131•	t22 ramp up = down	0.0...5...2000 s	
<b>14_ Rapid stop ramp</b>							
140/	t13 ramp stop	0.0...1...9.95		141•	t23 ramp stop	0.0...1...9.95	
<b>15_ Motorized potentiometer</b>							
150	Motorized pot.	Yes/no					
151	t4 Ramp up	1...10...60 s					
152	t4 Ramp down	1...10...60 s					
153	Save last position	Yes/no					
154	Motor pot + setpoint	No/sum					
<b>16_ 1st set fixed setpoints</b>				<b>17_ 2nd set fixed setpoints</b>			
160/	n11	0...5...400 Hz		170•	n21	0...5...400 Hz	
161/	n12	0...25...400 Hz		171•	n22	0...25...400 Hz	
162/	n13	0...50...400 Hz		172•	n23	0...50...400 Hz	
163•	Mix 1st set + n1	No/sum/ product		173•	Mix 2nd set + n1	No/sum/ product	
<b>18_ Setpoint hold function</b>							
180	Setp. hold function 1	Yes/no		183•	Setp. hold function 2	Yes/no	
181	Stop setpoint 1	0...2...25 Hz / ... mV		184•	Stop setpoint 2	0...2...25 Hz / ... mV	
182	Start hysteresis 1	0.1...2...5 Hz / ... mV		185•	Start hysteresis 2	0.1...2...5 Hz / ... mV	
<b>19_ Terminal control mode</b>							
190•	Control mode	STANDARD / 3-WIRE-CTRL					

Par.	Name	Setting range Factory setting	After start-up	Par.	Name	Setting range Factory setting	After start-up
	Switchable par. Parameter set 1				Parameter set 2		
<b>2_ FREQUENCY CHARACTERISTICS</b>							
<b>20_ Stepwise V/f pattern 1</b>				<b>21_ Stepwise V/f pattern 2</b>			
200/	f <sub>min</sub> 1	0...2...40 Hz		210•	f <sub>min</sub> 2	0...2...40 Hz	
201/	f <sub>base</sub> 1 stepwise	50/60/87/104/120 Hz		211•	f <sub>base</sub> 2 stepwise	50/60/87/104/120 Hz	
202/	f <sub>max</sub> 1	5...50...150 Hz		212•	f <sub>max</sub> 2	5...50...150 Hz	
<b>22_ Stepless V/f pattern 3</b>							
220	f <sub>min</sub> 3	0...2...150 Hz					
221	f <sub>base</sub> 3 stepless	5...50...400 Hz					
222	f <sub>max</sub> 3	5...50...400 Hz					
<b>23_ 1st frequency window skip</b>							
230•	1st freq. window	Yes/no					
231•	Window centre	5...50...150 Hz					
232•	Window width	± 2...9 Hz					
<b>25_ Selection V/f pattern</b>							
250	V/F pattern Parameter set 1	1/3		251•	V/F pattern Parameter set 2	2/3	
<b>26_ START/STOP frequency</b>							
260/	Set 1 START/STOP frequency	0...2...10 Hz		261•	Set 2 START/STOP frequency	0...2...10 Hz	
<b>3_ MOTOR PARAMETERS</b>							
<b>31_ Manual adjustment 1/1</b>				<b>33_ Manual adjustment 2/1</b>			
310	Motor rated curr. 1	20...90...200%		330•	Motor rated curr. 2	20...90...200%	
311	PWM fix 1	Yes/no		331•	PWM fix 2	Yes/no	
<b>32_ Manual adjustment 1/2</b>				<b>34_ Manual adjustment 2/2</b>			
320/	I <sub>max</sub> 1	20...150%		340•	I <sub>max</sub> 2	20...150%	
321/	BOOST 1	0...100%		341•	BOOST 2	0...100%	
322/	xR 1	0...100%		342•	xR 2	0...100%	
323/	Slip 1	0...10 Hz		343•	Slip 2	0...10 Hz	
324	Pole pair number 1	1/2/3/4/5/6		344•	Pole pair number 2	1/2/3/4/5/6	
325/	PWM frequency 1	4/8/12/16 kHz		345•	PWM frequency 2	4/8/12/16 kHz	
326/	Premagnet. time 1	0...100...300 ms		346•	Premagnet. time 2	0...100...300 ms	
327	Postmagnet. time 1	0...100...300 ms		347•	Postmagnet. time 2	0...100...300 ms	
328/	Motor size up 1	Yes/no		348•	Motor size up 2	Yes/no	
329/	Motor voltage 1	200...400...600 V		349•	Motor voltage 2	200...400...600 V	
<b>35_ Parameter switch over</b>							
350•	Enable parameter switchover	Yes/no					

Par.	Name	Setting range <b>Factory setting</b>	After start-up	Par.	Name	Setting range <b>Factory setting</b>	After start-up
	Switchable par. Parameter set 1				Parameter set 2		
<b>4_</b>	<b>REFERENCE SIGNALS</b>						
<b>40_</b>	<b>1st frequency reference values</b>						
400	1st frequency ref.	2... <b>50</b> ...150 Hz					
401	1st hysteresis	1... <b>2</b> ...9 Hz					
402	1st delay	<b>0</b> ...9 s					
403	1st signal = "1" at	$f > f_{Ref1} / f < f_{Ref1}$					
<b>41_</b>	<b>2nd frequency reference values</b>						
410•	2nd frequency ref.	2... <b>50</b> ...150 Hz					
411•	2nd hysteresis	1... <b>2</b> ...9 Hz					
412•	2nd delay	<b>0</b> ...9 s					
413•	2nd signal = "1" at	$f > f_{Ref2} / f < f_{Ref2}$					
<b>43_</b>	<b>Setpoint/actual value comparison</b>						
430•	Hysteresis	$\pm 1...2...9$ Hz					
431•	Signal = "1" at	<b>Actual = setp. / actual</b> $\lt \gt$ setp.					
<b>45_</b>	<b>1st current reference value</b>						
450•	1st current reference	10... <b>100</b> ...150%					
451•	1st hysteresis	$\pm 1...9\%$					
452•	1st delay	<b>0</b> ...9 s					
453•	1st signal = "1" at	$  <  _{Ref1} /   >  _{Ref1}$					
<b>46_</b>	<b>2nd current reference value</b>						
460•	2nd current reference	10... <b>100</b> ...150%					
461•	2nd hysteresis	$\pm 1...9\%$					
462•	2nd delay	<b>0</b> ...9 s					
463•	2nd signal = "1" at	$  <  _{Ref2} /   >  _{Ref2}$					
<b>47_</b>	<b>I<sub>max</sub> signal</b>						
470•	Signal = "1" at	$  =  _{max} /   <  _{max}$					
471•	Delay	<b>0</b> ...9 s					



Par.	Name	Setting range Factory setting	After start-up	Par.	Name	Setting range Factory setting	After start-up
	Switchable par. Parameter set 1				Parameter set 2		
<b>5_</b>	<b>MONITORING FUNCTIONS</b>						
<b>50_</b>	<b>Deceleration monitoring</b>						
500	Decel. monitoring	Yes/no					
501	f <sub>Ref3</sub>	10...99 Hz					
<b>51_</b>	<b>Motor mode speed monitoring</b>						
510	Motor mode speed monitoring 1	Yes/no		512	Motor mode speed monitoring 2	Yes/no	
511	Response time 1	0.1...1...9 s		513	Response time 2	0.1...1...9 s	
<b>52_</b>	<b>Regenerative mode speed monitoring</b>						
520	Regenerative mode speed monitoring 1	Yes/no		522	Regenerative mode speed monitoring 2	Yes/no	
521	Response time 1	0.1...1...9 s		523	Response time 2	0.1...1...9 s	
<b>53_</b>	<b>Power supply monitoring</b>						
530	Mains volt. monitor.	Yes/no					
<b>54_</b>	<b>Motor monitoring</b>						
541	Motor protection 1	Off/warning/ switch off		543	Motor protection 2	Off/warning/ switch off	
542	Cooling type 1	Fan cooled/ forced cooled		544	Cooling type 2	Fan cooled/ forced cooled	
<b>55_</b>	<b>Synchronous operation monitoring (only with FRS)</b>						
550	FRS alert	50...99 999 999					
551	FRS lag error	100...4000... 99 999 999					
552	Hold time	1...99 s					
553	Fault response	0/1-signal/coast/ stop/rapid stop					
554	Pos. tolerance slave	10...25...32 768					
555	LED counter V11	10...100...32 768					
556	Time constant position signal	5...10...2000 ms					
557	Cable break master-slave	Yes/no					
<b>56_</b>	<b>Fieldbus PD description</b>						
560	Setpoint descr. P01	Control word 1					
561	Act. value descr. P11	Status word 1					
562	Setpoint descr. P02	Speed					
563	Act. value descr. P12	Speed					
564	Setpoint descr. P03	No function					
565	Act. value descr. P13	No function					
<b>57_</b>	<b>Fieldbus parameters</b>						
570	Setpoint enable	Yes/no					
571	Fieldbus timeout	0.01...0.5...650 s					
572	Timeout response	Rapid stop + warn.					
573	CAN sync. ID	0...1...2047					
574	DeviceNet PD config	1 PD + PARAM / 1 PD 2 PD + PARAM / 2 PD 3 PD + PARAM / 3 PD					

Par.	Name	Setting range <b>Factory setting</b>	After start-up	Par.	Name	Setting range <b>Factory setting</b>	After start-up
	Switchable par. Parameter set 1				Parameter set 2		
<b>6__</b>	<b>TERMINAL ASSIGNMENT</b>						
<b>60_</b>	<b>Binary inputs 42-54</b>						
-	Basic unit TL. 41	fixed assigned to: <b>CW/stop</b>					
600	Basic unit TL. 42	<b>CCW/stop</b>		The following functions can be programmed: No function • CW/stop • CCW/stop • Enable • Param. switch • n11(n21) • n12(n22) • Reset • M pot up. • M pot down. • /dec. monitor • Ramp switch t2/t1 • /MC inhibit. • /ext. fault • FRS zero pt. • FRS control • SLAVE start • SLAVE free run. • /hold ctrl. • /limit switch CW • /limit switch CCW • Refer. cam • Ref. search • FRS teach in • Fix. setpt. sw • Setpoint active • Pattern			
601	Basic unit TL. 43	<b>Enable</b>					
602	Basic unit TL. 47	<b>Ramp switch t2/t1</b>					
603	Basic unit TL. 48	<b>n11 (n21)</b>					
604	Basic unit TL. 49	<b>n12 (n22)</b>					
605	With FEA/FIO TL. 50	<b>Param. switch</b>					
606	With FEA/FIO TL. 51	<b>Reset</b>					
607	With FIO TL. 52	<b>No function</b>					
608	With FIO TL. 53	<b>No function</b>					
609	With FIO TL. 54	<b>No function</b>					
<b>61_</b>	<b>Binary outputs 62-64, 69-72</b>						
-	Basic unit TL. 61	fixed assigned to: <b>/brake</b>					
611	Basic unit TL. 62	<b>/fault</b>		The following signals can be programmed: No function • MC ready • Rotating on • Rotating off • Brake applied • Manual operation • Parameter set • lxt warning • 1st f reference • 2nd f reference • Actual=setp. • 1st l reference • 2nd l reference • l max • /fault decel. • /fault • /fault ext. • /current >> • DC-link >> • /lxt >> • /temp. >> • f-resonance • /prewarn.FRS • /regen. FRS • Slave in pos. • /fault BRC • Brake released • Zero speed • Motor warn.1 • Motor warn.2 • At position • Output IPOS 1 • Output IPOS 2 • Output IPOS 3 • Output IPOS 4 • Output IPOS 5 • Output IPOS 6 • Output IPOS 7 • Output IPOS 8 • P. ZERO DEF.			
612	With FEA/FIO TL. 63	<b>lxt warning</b>					
613	With FEA/FIO TL. 64	<b>1st l reference</b>					
614	With FIO TL. 69	<b>No function</b>					
615	With FIO TL. 70	<b>No function</b>					
616	With FIO TL. 71	<b>No function</b>					
617	With FIO TL. 72	<b>No function</b>					
<b>63_</b>	<b>Analog outputs 38, 39, 65</b>						
630	Analog output 1 (TL. 38 only with FEA)	<b>Actual frequency</b>		The following functions can be programmed: Actual frequency • Actual speed • Ramp gen. • V motor • lxt value • Apparent l • Setp. frequency			
631	Factor output 1	0.1...1...3					
632	Analog output 2 (TL. 39 only with FEA)	<b>Apparent l</b>					
633	Factor output 1	0.1...1...3					
634	Meas. output (TL. 65 basic unit)	<b>Actual frequency</b>					
635	Factor meas. output	0.1...1...3					
<b>64_</b>	<b>Analog inputs 32-33, 36-37 (only with FEA)</b>						
640	Analog input 32/33 (only with FEA)	<b>Setpoint n1/ no function</b>					
641	Analog input 36/37 (only with FEA)	<b>No function/ ext. l limit</b>					

Par.	Name	Setting range <b>Factory setting</b>	After start-up	Par.	Name	Setting range <b>Factory setting</b>	After start-up
	Switchable par. Parameter set 1				Parameter set 2		
<b>7_ CONTROL FUNCTIONS</b>							
<b>71_ Hoist function</b>							
710/	Hoist function 1	Yes/no		712•	Hoist function 2	Yes/no	
<b>72_ Rapid start function</b>							
720	Rapid start 1	Yes/no		723•	Rapid start 2	Yes/no	
721	Field current 1	10... <b>35</b> ...50%		724•	Field current 2	10... <b>35</b> ...50%	
722	Duration 1	<b>3</b> ...180 s		725•	Duration 2	<b>3</b> ...180 s	
<b>73_ DC braking</b>							
730	DC braking 1	Yes/no		733•	DC braking 2	Yes/no	
731	DC brake time 1	0.1... <b>3</b> ...30 s		734•	DC brake time 2	0.1... <b>3</b> ...30 s	
732	DC hold current 1	0... <b>25</b> ...50%		735•	DC hold current 2	0... <b>25</b> ...50%	
<b>74_ Heating current</b>							
740	DC heat current 1	Yes/no		742•	DC heat current 2	Yes/no	
741	DC heat current 1	<b>0</b> ...50%		743•	DC heat current 2	<b>0</b> ...50%	
<b>76_ Synchronous operation</b>							
760•	Synchronous operat.	Yes/no		Synchronous operation only in parameter set 1.			
761•	MOVITRAC is	<b>Master</b> /slave					
762•	Master gear ratio fact.	1...3 999 999 999					
763•	Slave gear ratio fact.	1...3 999 999 999					
764•	Mode selection	<b>1</b> ...8					
765•	Slave counter	-99 999 999... <b>10</b> ... 99 999 999					
766•	Offset 1	-32 767... <b>10</b> ...32 767					
767•	Offset 2	-32 767... <b>10</b> ...32 767					
768•	Offset 3	-32 767... <b>10</b> ...32 767					
769•	Controller KP factor	1... <b>10</b> ...200					
<b>77_ Speed control</b>							
770•	Operation mode	<b>V/f control</b> / speed control/ positioning		Speed control and positioning only in parameter set 1.			
771•	P gain	0.1... <b>2</b> ...60					
772•	Time constant	1... <b>30</b> ...500 ms					
773•	Increments	128/256/512/ <b>1024</b> /2048					
774•	S×R	Yes/no					
777•	P precontrol	<b>0</b> ...60					
778•	Setpoint filter	0... <b>5</b> ...100 ms					
779•	P gain hold control	<b>0</b> ...60					

Par.	Name	Setting range <b>Factory setting</b>	After start-up	Par.	Name	Setting range <b>Factory setting</b>	After start-up
	Switchable par. Parameter set 1				Parameter set 2		
<b>8_</b>	<b>SPECIAL FUNCTIONS</b>						
<b>80_</b>	<b>Parameter menu</b>						
800/	Parameter lock	Yes/no					
801	Save	On/off					
802/	Short menu	On/off		Only with FBG31C keypad.			
<b>81_</b>	<b>Service informations</b>						
810	EPROM system	822 XXX X.XX		Read-only parameters.			
811	EPROM operation	821 XXX X.XX					
812•	EPROM fieldbus	821 XXX X.XX					
813	Service phone	0171-7210791					
<b>82_</b>	<b>Parameter copying</b>						
820	Copy from	MOVITRAC/EEPROM					
822	Copy	Yes/no					
<b>83_</b>	<b>Factory setting</b>						
830/	Factory setting	Yes/no					
831/	Selection	STANDARD/U.S.A./BRASIL		In size 0 it is not possible to select "BRASIL".			
<b>84_</b>	<b>Mode interfaces</b>						
841	Control mode	Standard/ Remote-setp./ Remote-CTRL/ Fieldbus					
842	Address inverter	0...63					
843	Response time	0...300 ms		Only with MC_SHELL and using the RS-485 interface.			
<b>85_</b>	<b>Language switching</b>						
850/	Language	DEUTSCH/ENGLISH/ FRANCAIS					
<b>86_</b>	<b>Reset mode</b>						
860	Auto reset mode	Yes/no					
861	Restart time	3...30 s					
862/	Pushbutton reset	Yes/no					
<b>87_</b>	<b>Manual operation</b>						
870	Manual operation	Yes/no					
<b>88_</b>	<b>Master-slave operation</b>						
880•	Master-save	Yes/no					
881•	MOVITRAC is	MASTER/SLAVE					
882•	Weighting factor	0.1...1...10					
<b>89_</b>	<b>4-quadrant operation</b>						
890/	4-quadrant 1	Yes/no		891•	4-quadrant 2	Yes/no	

## 4 Operation and Service

### 4.1 Operating displays

#### 4.1.1 LED display

LED V1 colour	Note / Explanation
yellow	Mains voltage is available, inverter is ready for operation.
green	Rotating field ON
red	Collective fault signal
yellow flashing	Self-test phase (duration max. 5 s) / factory setting (P830 = YES) running / fallen below permissible mains voltage range / external voltage (+24 V on TL.40) and no mains voltage
red-yellow flashing	Limit switch active
red-green flashing	Hold control active (IPOS)

#### 4.1.2 FBG31C keypad

##### Basic displays:

MC. INHIBITED

01795AEN

Display if mains OFF and 24 V<sub>DC</sub> external voltage or binary input "/MC. INHIBITED" = "0".

NO ENABLE

01595AEN

Display if X3:43 ("Enable/rapid stop") = "0".

NO ENABLE

01595AEN

Display if X2:41 ("CW/stop") **and** X3:42 ("CCW/stop") = "0".

FREQ. 30.00 Hz  
CURRT 78%

01773AEN

Display with inverter enabled.

WARNING XX

01781AEN

Coded displays

FAILURE XX  
XXXXXXXXXXXXXXXXXX

01782AEN

Fault display

**Functions:**

The FBG31C keypad allows complete parameter sets to be copied from one MOVITRAC® 31C unit into other MOVITRAC® 31C units. To do this, upload the parameter set from the MOVITRAC® 31C to the keypad with P820 “COPY FROM = MOVITRAC” and P822 “COPY = YES”. Plug the keypad onto another MOVITRAC® 31C unit and download the parameter set into the MOVITRAC® 31C with P820 “COPY FROM = EEPROM” and P822 “COPY = YES.” The FBG31C keypad can be removed and plugged in during operation.

If there is no connection between the inverter and the FBG31C keypad after switching on the mains and the 24 V supply and plugging in the FBG31C, the fault message COMMUNIC. ERROR NO SERIAL LINK is displayed. Try to establish communication by plugging in the keypad repeatedly.

**Selectable via menu:**

Fig. 23: Menu structure

01783AEN

- [←] [→] Change menu level, enter ([→]) or exit ([←]) editing mode in 3. menu level (parameter). The parameter can only be changed in the editing mode.
- [↑] [↓] Selection of the menu item, in editing mode value either greater or smaller. By releasing the [↑]- resp. [↓]-key, the new value becomes effective in the editing mode.
- [Q] Return to the basic display or, in P870 “MANUAL OPERATION = YES”, STOP command.
- [E] Manual operation: Exit manual operation  
In case of fault: Reset-parameter P862 is displayed and allows for clearing a fault.

### 4.1.3 FBG31C short menu

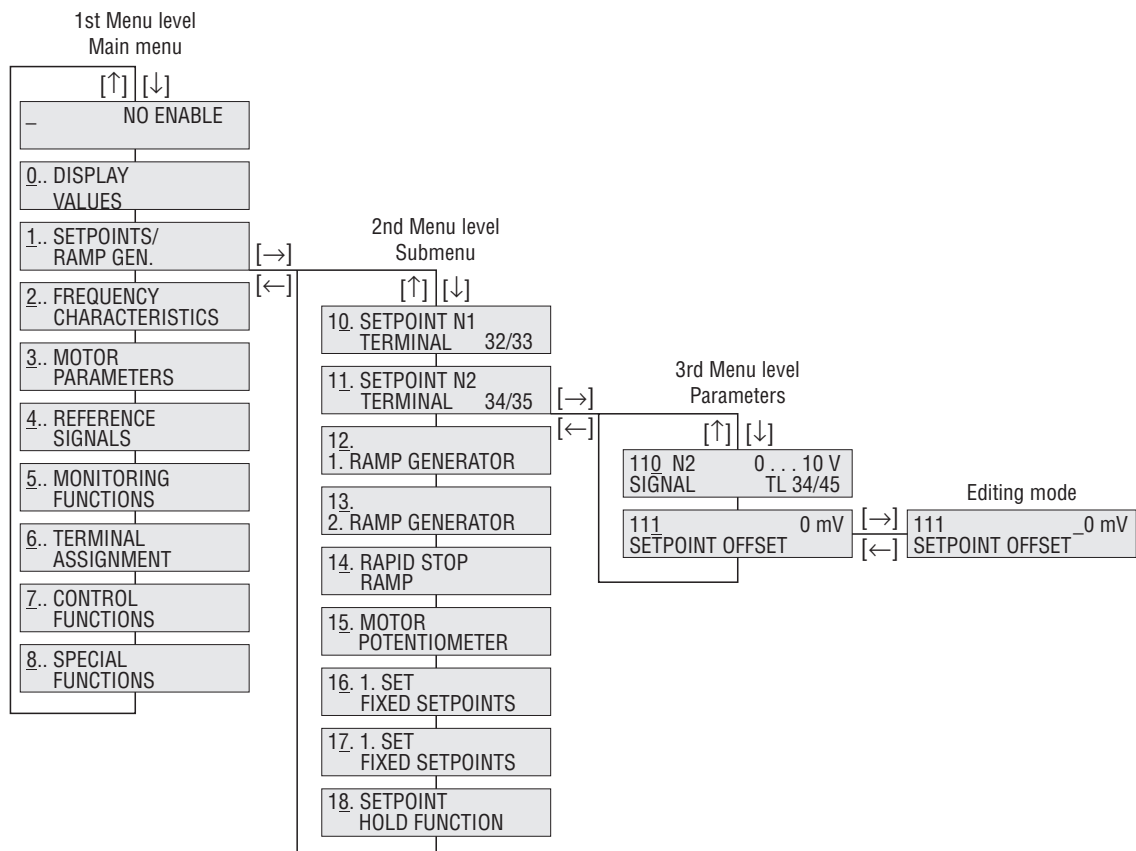
The FBG31C keypad provides a comprehensive parameter menu as well as a clearly arranged short menu, which contains the most-used parameters. The parameter P802 "SHORT MENU" allows for switching between the two different parameter menus. At the initial start-up of the MOVITRAC® 31C the short menu is active. When the short menu is active, all parameters are marked with a "/". In the complete parameter list (→ sec. 8.5) all parameters available with the short menu are marked with a "/" as well.

[↑]	[↓]			
<b>Basic display</b>	Frequency	0..400 Hz		
	Current	0..200 %		
	021 / Utilization	0..125 %		
	022 / Motor utilization	0..200 %		
	030 /	41:1 42:1 43:1 47:0	0/1	
	031 /	48:1 49:1 50:1 51:0	0/1	
	060 / Error t-0	No fault		
<b>11_ Setpoint n2</b>	110 / n-signal TL. 34/45	0..10 V		
<b>12_ Ramp 1</b>	120 / t11 ramp up	0,0..1..2000 s		
	121 / t11 ramp down	0,0..1..2000 s		
<b>13_ Ramp 2</b>	130 / t12 ramp up = down	0,0..5..2000 s		
<b>14_ Rapid stop</b>	140 / t13 ramp stop	0,0..1,0..9,95 s		
<b>16_ Fixed setpoints</b>	160 / n 11	0..5..400 Hz		
	161 / n 12	0..25..400 Hz		
	162 / n 13	0..50..400 Hz		
<b>20_ V/f pattern 1</b>	200 / f min 1	0..2..40 Hz		
	201 / f base 1	50/60/87/104/120 Hz		
	202 / f max 1	5..50..150 Hz		
<b>26_ Start/stop freq.</b>	260 / Start/stop frequency	0..2..10 Hz		
<b>32_ Motor adjustment</b>	320 / I max 1	20..150 %		
	321 / BOOST 1	0..100 %		
	322 / I x R 1	0..100 %		
	323 / Slip 1	0..10 Hz		
	325 / PWM frequency 1	4/8/12/16 kHz		
	326 / Premagnetization time 1	0..100...300 ms		
	328 / Motor size-up 1	Yes / No		
	329 / Motor voltage 1	200..400..600 V		
<b>71_ Hoist function</b>	710 / Hoist function 1	Yes / No		
<b>80_ Special functions</b>	800 / Parameter lock	Yes / No		
	802 / User menu	On / Off		
	830 / Factory setting	Yes / No		
	831 / Selection	STANDARD/USA/BRASIL		
	850 / Language	DEUTSCH/ENGLISH/FRANCAIS		
	862 / Pushbutton reset	Yes / No		
	890 / 4-quadrant mode	Yes / No		

Fig. 24: FBG31C Short menu

00508AEN



#### 4.1.4 MOVITRAC® 31C coded displays

During operation, the following messages may appear on the FBG31C (for about 2 s) or on the PC (resettable message):

Display	Meaning
16	Illegal index. *)
17	Function/parameter has not been implemented. *)
18	Read-only parameter.
19	Parameter lock (P800 = YES) active.
20	Factory setting (P830 = YES) is running.
21	Value is too large for this parameter.
22	Value is too small for this parameter.
23	Option required for the function or parameter selected is not installed.
24	Fault system software.
25	Access to selected parameter is prohibited via this serial interface.
27	Unauthorized access. *)
28	Access to the selected parameter is only possible when the inverter is inhibited. → Set TL. 43 = "0" or direction of rotation command = "0".
34	Hoist function set 1 (P710) can only be selected in 4-Q operation. → Activate 4-Q operation 1 (P890 = YES).
35	Hoist function set 2 (P712) can only be selected in 4-Q operation. → Activate 4-Q operation 2 (P891 = YES).
38	Hoist function set 1 (P710) only in 4-Q operation. → 4-Q operation 1 (P890) may not be switched off.
39	Hoist function set 2 (P712) only in 4-Q operation. → 4-Q operation 2 (P891) may not be switched off.
41	Parameter access is only possible via X4 (with FBG31C/USS11A/UST11A) when - manual operation is activated (P870 = YES) - or the master-slave function is activated (P880 = JA).
42	Activate speed control (P770 = speed control).
44	Motor size up 1 (P328) and Rapid start 1 (P720) cannot be activated simultaneously.
45	Motor size up 2 (P348) and Rapid start 2 (P723) cannot be activated simultaneously.
46	Option required (FEA31C/FIO31C) is not installed.
47	4-Q operation 1 (P890) and DC braking 1 (P730) cannot be activated simultaneously.
48	4-Q operation 2 (P891) and DC braking 2 (P733) cannot be activated simultaneously.
49	Controller inhibit active, function can only be activated if mains voltage is applied.
50	Synchronous operation (P760 = YES) must first be activated.
51	Synchronous operation "SLAVE" (P761) is still activated, no change possible..
53	3-WIRE-CTRL is active, REMOTE-CTRL cannot be activated.
54	REMOTE-CTRL is active, 3-WIRE-CTRL cannot be activated.

\*) This message does not appear if the SEW user software is installed. If necessary call the SEW Electronics Service.



## 4.2 Fault information

If a fault occurs, the red LED V1 lights up. Detailed fault indication is given on the FBG31C keypad or on the PC with MC\_SHELL. The fault memory (P060...P064) stores the most recent five fault signals (fault t-0...t-4) non-volatile. If more than five fault signals are generated, the oldest signal is deleted. The following data are stored when a fault occurs:

DC link voltage • I<sub>x</sub>t (utilization) • Heat sink temperature • Status of the binary inputs/outputs • Frequency • Parameter set 1/2 • Apparent current • Motor utilization.

Two responses are possible depending on the fault type; the inverter remains disabled in fault mode:

- **Immediate switch-off:**

The inverter can no longer accelerate the motor, the output stage is disabled in case of a fault and the brake is applied (X3:61 "/Brake" = "0").

- **Rapid stop:**

In this case the motor is decelerated using the rapid stop ramp t13/t23. When reaching the stop frequency the output stage becomes high-resistant and the brake is applied (X3:61 "/Brake" = "0").

**RESET:** A fault signal can be reset by:

- Power-down and power-up.  
Recommendation: for the mains contactor K11 a minimum power-down time of 10 s should be considered.
- Reset via input terminals, i.e. by a binary input assigned with the function "Reset" (P60\_).
- Manual reset in MC\_SHELL (P862 = "Yes" or menu item [Parameter] / [Manual Reset])
- Manual reset with FBG31C (Press the <E> key in case of a fault to change to parameter P862)
- Auto Reset executes max. three restart attempts with a settable restart time. Not recommended for drives where automatic restarting may result in injury to people and damage to property.



### 4.3 Fault signals

A fault is reset with RESET (→ sec. 4.2).

No.	Description	Response	Possible cause	Measure
1	Overcurrent	Immediate switch-off	<ul style="list-style-type: none"> <li>– Short circuit/earth fault at the output.</li> <li>– Motor too large.</li> <li>– Faulty output stage.</li> </ul>	<ul style="list-style-type: none"> <li>– Remove short-circuit.</li> <li>– Connect smaller motor.</li> <li>– If fault can still not be reset, contact SEW service.</li> </ul>
2	DC link voltage	Immediate switch-off	DC link voltage too high.	– Increase deceleration ramps.
3	Brake chopper	Immediate switch-off	<ul style="list-style-type: none"> <li>– Regenerative power too high</li> <li>– Braking resistor circuit interrupted</li> <li>– Short-circuit in the braking resistor circuit</li> <li>– Braking resistance value too high</li> <li>– Faulty brake chopper</li> </ul>	<ul style="list-style-type: none"> <li>– Increase deceleration ramps.</li> <li>– Check connecting leads of the braking resistor.</li> <li>– Check technical data of the braking resistor.</li> <li>– Exchange MOVITRAC® 31C.</li> </ul>
4	Cont. overload	Imm. sw. off	Max utilization too high (> 125%).	Reduce load.
5	Regenerative overload	Immediate switch-off	With active regen. n monit. (P520/P522) and speed control (P770): <ul style="list-style-type: none"> <li>– faulty encoder signals</li> <li>– wrong number of pole pairs (P324/P344)</li> <li>– value of increments (P773) not correct</li> </ul>	<ul style="list-style-type: none"> <li>– Check encoder.</li> <li>– Check encoder connection.</li> <li>– Set number of pole pairs correctly.</li> <li>– Set value of increments correctly.</li> </ul>
6	Over-temperature	Rapid stop	Thermal overload of the inverter.	Reduce load and / or ensure adequate cooling.
7	Phase failure	Immediate switch-off	With active mains volt. monitor.(P530) Phase missing at TL. X1:1/2/3.	Check mains supply.
10	Direction of rotation	Immediate switch-off	Only with active speed control (P770): <ul style="list-style-type: none"> <li>– Encoder tracks A/<math>\bar{A}</math> and B/<math>\bar{B}</math> are swapped in pairs.</li> <li>– Motor rotates in opposite direction.</li> <li>– Regen. overload (i.e. with sagging hoist) because of excessive load or BOOST setting too low (P321/P341).</li> </ul>	<ul style="list-style-type: none"> <li>– Check encoder connection.</li> <li>– Exchanging two motor phases.</li> <li>– Reduce load or increase BOOST.</li> </ul>
11	Speed detection	Immediate switch-off	Only with active speed control (P770): <ul style="list-style-type: none"> <li>– Faulty encoder connection.</li> <li>– FEN31C/FPI31C option not installed.</li> </ul>	<ul style="list-style-type: none"> <li>– Check encoder connection.</li> <li>– Insert correct option (FEN31C or FPI31C).</li> </ul>
12	Mot. overload	Immediate switch-off	With active n monit. (P510/P512) and speed control (P770): <ul style="list-style-type: none"> <li>– faulty encoder signals</li> <li>– wrong number of pole pairs (P324/P344)</li> <li>– value of increments (P773) not correct</li> </ul>	<ul style="list-style-type: none"> <li>– Check encoder.</li> <li>– Check encoder connection.</li> <li>– Set number of pole pairs correctly.</li> <li>– Set value of increments correctly.</li> </ul>
13	Starting conditions	Immediate switch-off	With active hoist function (P710/P712): Current too low during the premagnetization phase: <ul style="list-style-type: none"> <li>– Motor rated power selected too small in relation to the inverter rated power.</li> <li>– Cross-section of the motor leads too small.</li> </ul>	<ul style="list-style-type: none"> <li>– Check startup data and carry out new startup if necessary.</li> <li>– Check inverter-motor connection.</li> <li>– Check cross-section of the motor leads and increase if necessary.</li> </ul>
14	Output open	Immediate switch-off	With active hoist function (P710/P712): <ul style="list-style-type: none"> <li>– Two or all output phases interrupted.</li> <li>– Motor rated power selected too small in relation to the inverter rated power.</li> </ul>	<ul style="list-style-type: none"> <li>– Check inverter-motor connection.</li> <li>– Check startup data and carry out new startup if necessary.</li> </ul>

No.	Description	Response	Possible cause	Measure
17	Stack overflow	Immediate switch-off	Inverter electronics faulty. Possible cause: EMC effect.	The notes for EMC compliant installation must be observed.  The reset for error 25 consists of several steps: 1. Factory setting (P830 = YES) 2. Re-set matched parameters 3. Carry out reset  If fault occurs repeatedly, contact SEW service.
18	Stack underflow			
19	NMI trap			
20	Undefined opcode			
21	Protected instr.			
22	Word op. access			
23	Instruct. access			
24	Ext. bus access			
25	EEPROM	Rapid stop		
26	No connection			
27	Ext. terminal	Rapid stop	External fault signal has appeared at a programmable input	Eliminate the cause of the fault. Re-program the terminal, if necessary
28	Fault INTERBUS	Prog.	FFI31C and control mode (P841) = Fieldbus; Faulty monitoring signal.	Check Fieldbus connection.
32	Copying	No switch-off	Only when copying the parameters (P820): Break or interference in PC or FBG31C connection.	Check connection between inverter and PC. Remove FBG31C keypad and plug again.
33	Master-slave	Rapid stop	<ul style="list-style-type: none"> <li>–Connection master-slave is interrupted.</li> <li>–0V5 connection (RS-485) missing</li> <li>–Master or slave defined incorrectly in P880.</li> </ul>	<ul style="list-style-type: none"> <li>–Check master-slave connection.</li> <li>–0V5-establish connection between master and slave</li> <li>–Set P880 correctly.</li> </ul>
34	Fieldbus timeout	Immediate switch-off	No communication between master and slave within the specified time of the response monitoring.	<ul style="list-style-type: none"> <li>–Check communication routine of the master.</li> <li>–Increase fieldbus timeout time (P571)/ deactivate monitoring.</li> </ul>
35	Connection Encoder-FRS	Immediate switch-off	<ul style="list-style-type: none"> <li>–Encoder connection faulty.</li> <li>–Power supply of the encoder faulty.</li> </ul>	<ul style="list-style-type: none"> <li>–Check encoder connection.</li> <li>–Check power supply of the encoder.</li> </ul>
36	Connection Master-slave	Immediate switch-off	Only with FRS and cable break master-slave (P557) = YES: <ul style="list-style-type: none"> <li>–Setpoint connection of slave (TL. 98-101) is disrupted.</li> <li>–Master “Speed 0” → slave “FRS CTRL” is disrupted.</li> <li>–Slave “FRS CTRL” input not assigned.</li> <li>–Master “Speed 0” output not assigned.</li> <li>–No master inverter available.</li> <li>–Encoder &lt; 512 pulses per revolution used.</li> </ul>	<ul style="list-style-type: none"> <li>–Check installation.</li> <li>–Check programming of the binary inputs and binary outputs.</li> <li>–Check if encoder type is correct.</li> </ul>
37	FRS RAM fault	Immediate switch-off	Internal fault.	If fault occurs repeatedly, contact SEW service.
38	FRS process data fault	Immediate switch-off	Fault on interface between inverter and FRS.	If fault occurs repeatedly, contact SEW service.
39	FRS parameter data fault	Rapid stop	Invalid value for FRS parameters (P55_).	Check parameter settings.
41	FRS lag fault	Prog. (P553)	<ul style="list-style-type: none"> <li>–Polarity of the encoder not set correctly.</li> <li>–Acceleration ramps too short.</li> <li>–P-gain of the positioning controller too small</li> <li>–Speed controller not set property.</li> <li>–Value for lag error tolerance too small</li> </ul>	<ul style="list-style-type: none"> <li>–Change polarity of encoder.</li> <li>–Increase ramps.</li> <li>–Increase P-gain.</li> <li>–Select new parameters for speed controller.</li> <li>–Increase lag error tolerance (P551).</li> <li>–Check wiring of encoder, motor and mains phases.</li> <li>–Check if mechanical system is sluggish or whether drive hit an obstacle.</li> </ul>

No.	Description	Response	Possible cause	Measure
43	Fault binary output	Immediate switch-off	<ul style="list-style-type: none"> <li>– Load on TL. X3:61 &gt; 150 mA.</li> <li>– Load on the other binary outputs &gt; 50 mA</li> <li>– Short circuit on binary output.</li> <li>– Capacitive load on binary output.</li> </ul>	Check installation of the binary outputs.
44	Static RAM	Immediate switch-off	Inverter electronics faulty. Possible cause: EMC effect.	The notes for EMC compliant installation must be observed. If fault occurs repeatedly contact SEW service.
45	PC timeout			
50	Limit switch missing	Immediate switch-off	Not on size 0: Limit switch not connected or wire break.	Check wiring of the limit switches.
51	Zero pulse missing	Immediate switch-off	Only with IPOS: Encoder faulty or cable break or track K0/K0̄ (=C/C̄) not connected to FPI.	<ul style="list-style-type: none"> <li>– Check wiring of the encoder.</li> <li>– Check the encoder for correct functioning.</li> </ul>
52	Limit switches reversed	Immediate switch-off	Not on size 0: Limit switches are reversed with respect to the direction motor-movement.	<ul style="list-style-type: none"> <li>– Check wiring of the limit switches.</li> <li>– Exchange limit switch connections.</li> <li>– Reprogram terminals.</li> </ul>
53	Reference cam	Immediate switch-off	Only with IPOS: Reference cam missing.	Check installation.
54	Motor overload	Rapid stop	Motor utilization too high.	<ul style="list-style-type: none"> <li>– Reduce load.</li> <li>– Increase ramps.</li> <li>– Increase duration of rest period.</li> </ul>
55	Invalid IPOS command	Rapid stop	Only with IPOS: No program or wrong program (e.g. after factory setting).	Check the content of the program memory.
56	User watchdog (in positioning program)	Rapid stop	Only with IPOS: System fault or wrong time setting.	Check use of the watchdog function.
57	Teach error	Rapid stop	Only with IPOS: Teach procedure incorrect.	Check teach procedure.
58	Invalid control word	Rapid stop	Only with IPOS: An attempt has been made to set an invalid automatic mode.	Check the serial connection and the setting value of the external control.
59	Software limit switches	Rapid stop	Only with IPOS: Target position lies outside the software limit switch range.	Check the software limit switch range and travel program.
60	Lag error	Rapid stop	Only with IPOS: <ul style="list-style-type: none"> <li>– system fault.</li> <li>– Value for lag error tolerance too small.</li> <li>– Speed controller not set property.</li> </ul>	<ul style="list-style-type: none"> <li>– Check setting of parameter “FRS LAG ERROR” (P551).</li> <li>– Optimize speed controller setting.</li> </ul>
61	Fault during reference travel	Immediate switch-off	Only with IPOS: <ul style="list-style-type: none"> <li>– Reference cam missing.</li> <li>– Incorrect limit switch connection.</li> <li>– Reference type changed during reference travel.</li> </ul>	Check the reference type and its corresponding requirements.
62	Index overflow	Immediate switch-off	Only with IPOS: Programming error.	Check and correct user program.
63	Jump command error	Rapid stop	Only with IPOS: Jump to invalid label.	Loading the positioning program again.
64	Limit switch CW	Rapid stop	Not on size 0: Limit switch CW approached or wire break.	Check the travel program or the limit switch wiring.
65	Limit switch CCW	Rapid stop	Not on size 0: Limit switch CCW approached or wire break.	Check the travel program or the limit switch wiring.
66	Hardware configuration	Immediate switch-off	System software missing.	Size 0: contact SEW service. Size 1-4: plug correct option into X20.
67	HW watchdog timer	Immediate switch-off	Internal fault	Reset the inverter. If fault occurs repeatedly contact SEW service.

#### 4.4 SEW Electronics Service

If a fault cannot be corrected, then please contact **SEW Electronics Service** (→ "After-Sales Service and Spare Parts").

##### If you return equipment for repair, please state:

- Serial number (→ nameplate)
- Type designation
- Service code data from the service label
- Description of the application (drive situation, control via terminals or serial interface)
- Connected motor (motor rated voltage,  $\Upsilon$  or  $\Delta$  connection)
- Options installed
- Nature of the fault
- Circumstances the fault occurred under
- Suspected cause
- Any abnormal circumstances, etc, that may have caused the fault.

The MOVITRAC<sup>®</sup> 31C units have a service label, which is attached next to the nameplate and the option label.

Example:

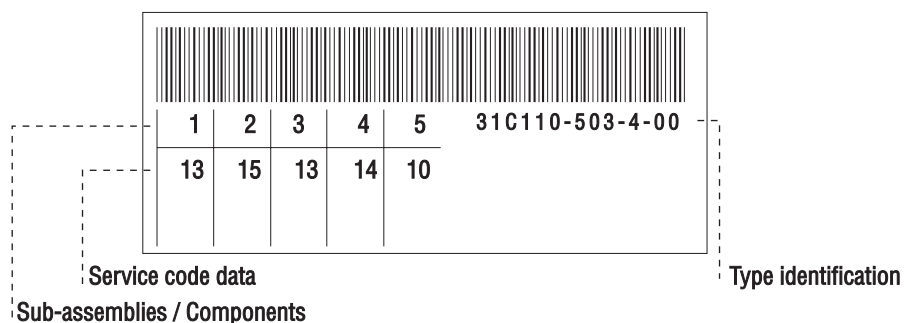

Fig. 25: Service label

00591AEN

## 5 Technical Data

### 5.1 Basic units

#### 5.1.1 General technical data

The following table contains the technical data for all MOVITRAC<sup>®</sup> 31C frequency inverters, independent of size and rated power.

MOVITRAC <sup>®</sup> 31C	all unit sizes
Immunity to interference	complies with EN 61800 - 3
Interference emission with EMC-compliant wiring	conforms with interference suppression level B to EN 55011 and EN 55014 complies with EN 61800 - 3
Ambient temperature*) Derating Ambient conditions	$\vartheta_{amb}$ 0°...+45°C $P_N$ -reduction: 3.0% $I_N$ per K up to max. 60°C EN 60721-3-3, class 3K3
Storage temperature**)	$\vartheta_{storage}$ -25°C...+70°C (EN 60721-3-3, class 3K3) FBG keypad: -20°C...+60°C
Enclosure	IP20 (EN 60529 / NEMA1)
Duty type	DB (EN 60149-1-1 and 1-3)
Altitude of installation	$h \leq 1000\text{m}$ $I_N$ -reduction: 1% per 100 m (330 ft) from 1000 m (3300 ft) up to max. 2000 m (6600 ft)

\*) Units for  $\vartheta_{amb} < 0^\circ\text{C}$  on request.

\*\*) In the case of extended storage, connect the unit to the mains supply for at least 5 minutes every 2 years, as otherwise the service life of the unit may be reduced.

### MOVITRAC<sup>®</sup> 31C Unit Family



Fig. 26: MOVITRAC<sup>®</sup> 31C Unit Family

00578EXX

## 5.2 MOVITRAC® 31C...-233 (230 V Units)

### 5.2.1 Basic units, sizes 0 and 1

MOVITRAC® 31C	005-233-4-00	011-233-4-00	008-233-4-00	015-233-4-00	022-233-4-00	
Part number	826 321 3	826 322 1	826 323 X	826 324 8	826 325 6	
Size	0		1			
<b>INPUT</b>						
Input voltages Permissible range	$V_{in}$	$3 \times 230 V_{AC}$ $V_{in} = 200V_{AC} - 10\% \dots 240V_{AC} + 10\%$				
Input frequency	$f_{in}$	50 Hz ... 60 Hz $\pm$ 5%				
Rated input current (at $V_{in} = 3 \times 230V_{AC}$ )	$I_{in}$ 100% 125%	2.8 A <sub>AC</sub> 3.5 A <sub>AC</sub>	4.0 A <sub>AC</sub> 5.0 A <sub>AC</sub>	3.3 A <sub>AC</sub> 4.1 A <sub>AC</sub>	6.7 A <sub>AC</sub> 8.4 A <sub>AC</sub>	7.8 A <sub>AC</sub> 9.8 A <sub>AC</sub>
<b>OUTPUT</b>						
Rated output power (at $V_{in} = 3 \times 200 \dots 240V_{AC}$ )	$P_N$	1.3 kVA	2.0 kVA	1.6 kVA	2.7 kVA	3.4 kVA
Rated output current (at $V_{in} = 3 \times 230V_{AC}$ )	$I_N$	3.2 A <sub>AC</sub>	4.9 A <sub>AC</sub>	4.0 A <sub>AC</sub>	7.3 A <sub>AC</sub>	8.6 A <sub>AC</sub>
Cont. output current = 125% $I_N^*$ (at $V_{in} = 3 \times 230V_{AC}$ )	$I_{cont}$	4.0 A <sub>AC</sub>	6.1 A <sub>AC</sub>	5.0 A <sub>AC</sub>	9.1 A <sub>AC</sub>	10.8 A <sub>AC</sub>
Constant load Recommended motor power	$P_{Mot}$	0.55 kW (0.75 HP)	1.1 kW (1.5 HP)	0.75 kW (1.0 HP)	1.5 kW (2.0 HP)	2.2 kW (3.0 HP)
Variable torque load and constant load without overload Recommended motor power	$P_{Mot}$	0.75 kW (1.0 HP)	1.5 kW (2.0 HP)	1.1 kW (1.5 HP)	2.2 kW (3.0 HP)	3.0 kW (4.0 HP)
Current limit	$I_{max}$	Motive: 150% $I_N$ Regenerative: 150% $I_N$ Duration depending on utilization				
Internal current limit		$I_{max} = 20 \dots 150\%$ set via menu (P320 / P340)				
Minimum braking resistance value for 4-Q operation	$R_{BW}$	68 $\Omega$ -10%		33 $\Omega$ -10%		
Output voltage	$V_{out}$	Adjustable with parameter P329/P349, however max. $V_{in}$				
Output frequency resolution base frequency	$f_{out}$ $\Delta f_{out}$ $f_{base}$	0...400 Hz, $f_{min} = 0 \dots 40$ Hz, $f_{max} = 5 \dots 400$ Hz 0.05 Hz over the entire range In steps: 50/60/87/104/120 Hz and continuously: 5...400 Hz				
PWM frequency	$f_{PWM}$	Adjustable: 4/8/12/16 kHz (P325/P345)				
<b>GENERAL</b>						
Power losses at $P_N$	$P_{lossmax}$	54 W	75 W	70 W	110 W	126 W
Cooling method (DIN 41751) fan cooling forced cooling/required air flow		40 m <sup>3</sup> /h (24 ft <sup>3</sup> /min)		•	25 m <sup>3</sup> /h (15 ft <sup>3</sup> /min)	
Weight		2.4 kg (5.3 lb)	2.5 kg (5.5 lb)	4.5 kg (9.9 lb)		
Dimensions	W×H×D	105 × 188 × 189 mm (4.13 × 7.40 × 7.44 in)		184 × 281 × 170 mm (7.24 × 11.06 × 6.69 in)		

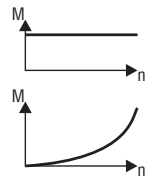

\*) applies to  $f_{PWM} = 4$  kHz

**To provide sufficient cooling leave a minimum clearance of 100 mm (4 in) above and below each unit.**

Power ratings are based on a default setting of 4 kHz for the PWM frequency (P325/P345).

## 5.2.2 Basic units, sizes 2 and 3

MOVITRAC® 31C	037-233-4-00	055-233-4-00	075-233-4-00
Part number	826 326 4	826 327 2	826 328 0
Size	2	3	
<b>INPUT</b>			
Input voltages Permissible range	$V_{in}$	$3 \times 230 V_{AC}$ $V_{in} = 200V_{AC} - 10\% \dots 240V_{AC} + 10\%$	
Input frequency	$f_{in}$	50 Hz ... 60 Hz $\pm$ 5%	
Rated input current (at $V_{in} = 3 \times 230V_{AC}$ )	$I_{in}$ 100% 125%	14.2 A <sub>AC</sub> 17.8 A <sub>AC</sub>	19.5 A <sub>AC</sub> 24.4 A <sub>AC</sub>
<b>OUTPUT</b>			
Rated output power (at $V_{in} = 3 \times 200 \dots 240V_{AC}$ )	$P_N$	6.4 kVA	8.8 kVA
Rated output current (at $V_{in} = 3 \times 230V_{AC}$ )	$I_N$	16 A <sub>AC</sub>	22 A <sub>AC</sub>
Cont. output current = 125% $I_N^*$ (at $V_{in} = 3 \times 230V_{AC}$ )	$I_{cont}$	20 A <sub>AC</sub>	27.5 A <sub>AC</sub>
Constant load Recommended motor power	$P_{Mot}$	3.7 kW (5.0 HP)	5.5 kW (7.5 HP)
Variable torque load and constant load without overload Recommended motor power	$P_{Mot}$	5.5 kW (7.5 HP)	7.5 kW (10 HP)
Current limit	$I_{max}$	Motive: 150% $I_N$ Regenerative: 150% $I_N$ Duration depending on utilization	
Internal current limit		$I_{max} = 20 \dots 150\%$ set via menu (P320 / P340)	
Minimum braking resistance value for 4-Q operation	$R_{BW}$	27 $\Omega$ -10%	11 $\Omega$ -10%
Output voltage	$V_{out}$	Adjustable with parameter P329/P349, however max. $V_{in}$	
Output frequency resolution base frequency	$f_{out}$ $\Delta f_{out}$ $f_{base}$	0...400 Hz, $f_{min} = 0 \dots 40$ Hz, $f_{max} = 5 \dots 400$ Hz 0.05 Hz over the entire range In steps: 50/60/87/104/120 Hz and continuously: 5...400 Hz	
PWM frequency	$f_{PWM}$	Adjustable: 4/8/12/16 kHz (P325/P345)	
<b>GENERAL</b>			
Power losses at $P_N$	$P_{lossmax}$	223 W	305 W
Cooling method (DIN 41751) fan cooling forced cooling/required air flow		50 m <sup>3</sup> /h (30 ft <sup>3</sup> /min)	100 m <sup>3</sup> /h (60 ft <sup>3</sup> /min)
Weight		5.9 kg (13 lb)	13 kg (28.7 lb)
Dimensions	W×H×D	184 × 296 × 218 mm (7.24 × 11.65 × 8.58 in)	220 × 405 × 264 mm (8.66 × 15.94 × 10.39 in)

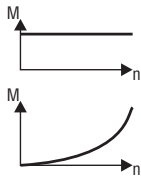

\*) applies to  $f_{PWM} = 4$  kHz

**To provide sufficient cooling leave a minimum clearance of 100 mm (4 in) above and below each unit.**

Power ratings are based on a default setting of 4 kHz for the PWM frequency (P325/P345).



### 5.3 MOVITRAC® 31C...-503 (400/500 V Units)

#### 5.3.1 Basic units, size 0

MOVITRAC® 31C	005-503-4-00	007-503-4-00	011-503-4-00	014-503-4-00	
Part number	826 078 8	826 079 6	826 080 X	826 374 4	
<b>INPUT</b>					
Input voltages Permissible range	$V_{in}$ 3 x 380 V <sub>AC</sub> / 400 V <sub>AC</sub> / 415 V <sub>AC</sub> / 460 V <sub>AC</sub> / 480 V <sub>AC</sub> / 500 V <sub>AC</sub> $V_{in} = 380V_{AC} - 10\% \dots 500V_{AC} + 10\%$				
Input frequency	$f_{in}$ 50 Hz ... 60 Hz ± 5%				
Rated input current (at $V_{in} = 3 \times 400V_{AC}$ )	$I_{in}$ 100% 125%	1.6 A <sub>AC</sub> 1.9 A <sub>AC</sub>	1.9 A <sub>AC</sub> 2.4 A <sub>AC</sub>	2.4 A <sub>AC</sub> 2.9 A <sub>AC</sub>	3.5 A <sub>AC</sub> 4.4 A <sub>AC</sub>
<b>OUTPUT</b>					
Rated output power (at $V_{in} = 3 \times 380 \dots 500V_{AC}$ )	$P_N$	1.4 kVA	1.8 kVA	2.2 kVA	2.8 kVA
Rated output current (at $V_{in} = 3 \times 400V_{AC}$ )	$I_N$	2.0 A <sub>AC</sub>	2.5 A <sub>AC</sub>	3.2 A <sub>AC</sub>	4.0 A <sub>AC</sub>
Cont. output current = 125% $I_N^*$ (at $V_{in} = 3 \times 400V_{AC}$ )	$I_{cont}$	2.5 A <sub>AC</sub>	3.1 A <sub>AC</sub>	4.0 A <sub>AC</sub>	5.0 A <sub>AC</sub>
Constant load Recommended motor power	$P_{Mot}$	0.55 kW (0.75 HP)	0.75 kW (1.0 HP)	1.1 kW (1.5 HP)	1.5 kW (2.0 HP)
Variable torque load and constant load without overload Recommended motor power	$P_{Mot}$	0.75 kW (1.0 HP)	1.1 kW (1.5 HP)	1.5 kW (2.0 HP)	2.2 kW (3.0 HP)
Current limit	$I_{max}$	Motive: 150% $I_N$ Regenerative: 150% $I_N$			Duration depending on utilization
Internal current limit		$I_{max} = 20 \dots 150\%$ set via menu (P320 / P340)			
Minimum braking resistance value for 4-Q operation	$R_{BW}$	200 Ω -10%			
Output voltage	$V_{out}$	Adjustable with parameter P329/P349, however max. $V_{in}$			
Output frequency resolution base frequency	$f_{out}$ $\Delta f_{out}$ $f_{base}$	0...400 Hz, $f_{min} = 0 \dots 40$ Hz, $f_{max} = 5 \dots 400$ Hz 0.05 Hz over the entire range In steps: 50/60/87/104/120 Hz and continuously: 5...400 Hz			
PWM frequency	$f_{PWM}$	Adjustable: 4/8/12/16 kHz (P325/P345)			
<b>GENERAL</b>					
Power losses at $P_N$	$P_{lossmax}$	46 W	54 W	68 W	75 W
Cooling method (DIN 41751) fan cooling forced cooling/required air flow		•	•	40 m <sup>3</sup> /h (24 ft <sup>3</sup> /min)	
Weight		2.4 kg (5.3 lb)		2.5 kg (5.5 lb)	
Dimensions	W×H×D	105 × 188 × 189 mm (4.13 × 7.40 × 7.44 in)			

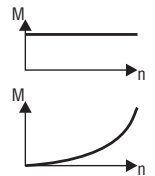

\*) applies to  $f_{PWM} = 4$  kHz

**To provide sufficient cooling leave a minimum clearance of 100 mm (4 in) above and below each unit.**

Power ratings are based on a default setting of 4 kHz for the PWM frequency (P325/P345).

For  $V_{mains} = 3 \times 500 V_{AC}$  the permissible input and output currents are reduced by 20 % compared to the rated values.

## 5.3.2 Basic units, size 1

MOVITRAC® 31C		008-503-4-00	015-503-4-00	022-503-4-00	030-503-4-00
Part number		826 332 9	826 333 7	826 334 5	826 335 3
<b>INPUT</b>					
Input voltages Permissible range	$V_{in}$	3 x 380 V <sub>AC</sub> / 400 V <sub>AC</sub> / 415 V <sub>AC</sub> / 460 V <sub>AC</sub> / 480 V <sub>AC</sub> / 500 V <sub>AC</sub> $V_{in} = 380V_{AC} - 10\% \dots 500V_{AC} + 10\%$			
Input frequency	$f_{in}$	50 Hz ... 60 Hz ± 5%			
Rated input current (at $V_{in} = 3 \times 400V_{AC}$ )	$I_{in}$ 100% 125%	2.0 A <sub>AC</sub> 2.5 A <sub>AC</sub>	3.5 A <sub>AC</sub> 4.4 A <sub>AC</sub>	5.0 A <sub>AC</sub> 6.3 A <sub>AC</sub>	6.7 A <sub>AC</sub> 8.4 A <sub>AC</sub>
<b>OUTPUT</b>					
Rated output power (at $V_{in} = 3 \times 380 \dots 500V_{AC}$ )	$P_N$	1.8 kVA	2.8 kVA	3.8 kVA	5.1 kVA
Rated output current (at $V_{in} = 3 \times 400V_{AC}$ )	$I_N$	2.5 A <sub>AC</sub>	4.0 A <sub>AC</sub>	5.5 A <sub>AC</sub>	7.3 A <sub>AC</sub>
Cont. output current = 125% $I_N^*$ (at $V_{in} = 3 \times 400V_{AC}$ )	$I_{cont}$	3.1 A <sub>AC</sub>	5.0 A <sub>AC</sub>	6.9 A <sub>AC</sub>	9.1 A <sub>AC</sub>
Constant load Recommended motor power	$P_{Mot}$	0.75 kW (1.0 HP)	1.5 kW (2.0 HP)	2.2 kW (3.0 HP)	3.0 kW (4.0 HP)
Variable torque load and constant load without overload Recommended motor power	$P_{Mot}$	1.1 kW (1.5 HP)	2.2 kW (3.0 HP)	3.0 kW (4.0 HP)	4.0 kW (5.0 HP)
Current limit	$I_{max}$	Motive: 150% $I_N$ Regenerative: 150% $I_N$ Duration depending on utilization			
Internal current limit		$I_{max} = 20 \dots 150\%$ set via menu (P320 / P340)			
Minimum braking resistance value for 4-Q operation	$R_{BW}$	47 Ω -10%			
Output voltage	$V_{out}$	Adjustable with parameter P329/P349, however max. $V_{in}$			
Output frequency resolution base frequency	$f_{out}$ $\Delta f_{out}$ $f_{base}$	0...400 Hz, $f_{min} = 0 \dots 40$ Hz, $f_{max} = 5 \dots 400$ Hz 0.05 Hz over the entire range In steps: 50/60/87/104/120 Hz and continuously: 5...400 Hz			
PWM frequency	$f_{PWM}$	Adjustable: 4/8/12/16 kHz (P325/P345)			
<b>GENERAL</b>					
Power losses at $P_N$	$P_{lossmax}$	65 W	85 W	105 W	130 W
Cooling method (DIN 41751) fan cooling forced cooling/required air flow		•	•	25 m <sup>3</sup> /h (15 ft <sup>3</sup> /min)	
Weight		4.5 kg (9.9 lb)			
Dimensions	W×H×D	184 × 281 × 170 mm (7.24 × 11.06 × 6.69 in)			

\*) applies to  $f_{PWM} = 4$  kHz

**To provide sufficient cooling leave a minimum clearance of 100 mm (4 in) above and below each unit.**

Power ratings are based on a default setting of 4 kHz for the PWM frequency (P325/P345).

For  $V_{mains} = 3 \times 500 V_{AC}$  the permissible input and output currents are reduced by 20 % compared to the rated values.

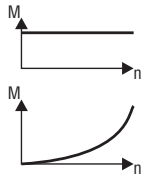

5.3.3 Basic units, size 2

MOVITRAC® 31C		040-503-4-00	055-503-4-00	075-503-4-00
Part number		826 336 1	826 337 X	826 338 8
<b>INPUT</b>				
Input voltages Permissible range	$V_{in}$	3 x 380 V <sub>AC</sub> / 400 V <sub>AC</sub> / 415 V <sub>AC</sub> / 460 V <sub>AC</sub> / 480 V <sub>AC</sub> / 500 V <sub>AC</sub> $V_{in} = 380V_{AC} - 10\% \dots 500V_{AC} + 10\%$		
Input frequency	$f_{in}$	50 Hz ... 60 Hz ± 5%		
Rated input current (at $V_{in} = 3 \times 400V_{AC}$ )	$I_{in}$ 100% 125%	8.8 A <sub>AC</sub> 11 A <sub>AC</sub>	10.7 A <sub>AC</sub> 13.4 A <sub>AC</sub>	13.8 A <sub>AC</sub> 17.3 A <sub>AC</sub>
<b>OUTPUT</b>				
Rated output power (at $V_{in} = 3 \times 380 \dots 500V_{AC}$ )	$P_N$	6.6 kVA	8.3 kVA	11 kVA
Rated output current (at $V_{in} = 3 \times 400V_{AC}$ )	$I_N$	9.6 A <sub>AC</sub>	12 A <sub>AC</sub>	16 A <sub>AC</sub>
Cont. output current = 125% $I_N^{*}$ (at $V_{in} = 3 \times 400V_{AC}$ )	$I_{cont}$	12 A <sub>AC</sub>	15 A <sub>AC</sub>	20 A <sub>AC</sub>
Constant load Recommended motor power	$P_{Mot}$	4.0 kW (5.0 HP)	5.5 kW (7.5 HP)	7.5 kW (10 HP)
Variable torque load and constant load without overload Recommended motor power	$P_{Mot}$	5.5 kW (7.5 HP)	7.5 kW (10 HP)	11 kW (15 HP)
Current limit	$I_{max}$	Motive: 150% $I_N$ Regenerative: 150% $I_N$ Duration depending on utilization		
Internal current limit		$I_{max} = 20 \dots 150\%$ set via menu (P320 / P340)		
Minimum braking resistance value for 4-Q operation	$R_{BW}$	47 Ω -10%		
Output voltage	$V_{out}$	Adjustable with parameter P329/P349, however max. $V_{in}$		
Output frequency resolution base frequency	$f_{out}$ $\Delta f_{out}$ $f_{base}$	0...400 Hz, $f_{min} = 0 \dots 40$ Hz, $f_{max} = 5 \dots 400$ Hz 0.05 Hz over the entire range In steps: 50/60/87/104/120 Hz and continuously: 5...400 Hz		
PWM frequency	$f_{PWM}$	Adjustable: 4/8/12/16 kHz (P325/P345)		
<b>GENERAL</b>				
Power losses at $P_N$	$P_{lossmax}$	190 W	230 W	310 W
Cooling method (DIN 41751) fan cooling forced cooling/required air flow		50 m <sup>3</sup> /h (30 ft <sup>3</sup> /min)		
Weight		5.9 kg (13 lb)		
Dimensions	W×H×D	184 × 296 × 218 mm (7.24 × 11.65 × 8.58 in)		

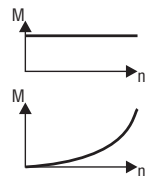

\*) applies to  $f_{PWM} = 4$  kHz

**To provide sufficient cooling leave a minimum clearance of 100 mm (4 in) above and below each unit.**

Power ratings are based on a default setting of 4 kHz for the PWM frequency (P325/P345).

For  $V_{mains} = 3 \times 500 V_{AC}$  the permissible input and output currents are reduced by 20 % compared to the rated values.

## 5.3.4 Basic units, size 3

MOVITRAC® 31C		110-503-4-00	150-503-4-00	220-503-4-00
Part number		826 308 6	826 309 4	826 310 8
<b>INPUT</b>				
Input voltages Permissible range	$V_{in}$	3 x 380 V <sub>AC</sub> / 400 V <sub>AC</sub> / 415 V <sub>AC</sub> / 460 V <sub>AC</sub> / 480 V <sub>AC</sub> / 500 V <sub>AC</sub> $V_{in} = 380V_{AC} - 10\% \dots 500V_{AC} + 10\%$		
Input frequency	$f_{in}$	50 Hz ... 60 Hz ± 5%		
Rated input current (at $V_{in} = 3 \times 400V_{AC}$ )	$I_{in}$ 100% 125%	20 A <sub>AC</sub> 24 A <sub>AC</sub>	27 A <sub>AC</sub> 33 A <sub>AC</sub>	39 A <sub>AC</sub> 49 A <sub>AC</sub>
<b>OUTPUT</b>				
Rated output power (at $V_{in} = 3 \times 380 \dots 500V_{AC}$ )	$P_N$	17 kVA	23 kVA	33 kVA
Rated output current (at $V_{in} = 3 \times 400V_{AC}$ )	$I_N$	24 A <sub>AC</sub>	33 A <sub>AC</sub>	47 A <sub>AC</sub>
Cont. output current = 125% $I_N^*$ (at $V_{in} = 3 \times 400V_{AC}$ )	$I_{cont}$	30 A <sub>AC</sub>	41 A <sub>AC</sub>	58 A <sub>AC</sub>
Constant load Recommended motor power	$P_{Mot}$	11 kW (15 HP)	15 kW (20 HP)	22 kW (30 HP)
Variable torque load and constant load without overload Recommended motor power	$P_{Mot}$	15 kW (20 HP)	22 kW (30 HP)	30 kW (40 HP)
Current limit	$I_{max}$	Motive: 150% $I_N$ Regenerative: 150% $I_N$ Duration depending on utilization		
Internal current limit		$I_{max} = 20 \dots 150\%$ set via menu (P320 / P340)		
Minimum braking resistance value for 4-Q operation	$R_{BW}$	18 Ω -10%		15 Ω -10%
Output voltage	$V_{out}$	Adjustable with parameter P329/P349, however max. $V_{in}$		
Output frequency resolution base frequency	$f_{out}$ $\Delta f_{out}$ $f_{base}$	0...400 Hz, $f_{min} = 0 \dots 40$ Hz, $f_{max} = 5 \dots 400$ Hz 0.05 Hz over the entire range In steps: 50/60/87/104/120 Hz and continuously: 5...400 Hz		
PWM frequency	$f_{PWM}$	Adjustable: 4/8/12/16 kHz (P325/P345)		
<b>GENERAL</b>				
Power losses at $P_N$	$P_{lossmax}$	430 W	580 W	800 W
Cooling method (DIN 41751) fan cooling forced cooling/required air flow		100 m <sup>3</sup> /h (60 ft <sup>3</sup> /min)	230 m <sup>3</sup> /h (135 ft <sup>3</sup> /min)	
Weight		13 kg (28.7 lb)		
Dimensions	W×H×D	220 × 405 × 264 mm (8.66 × 15.94 × 10.39 in)		

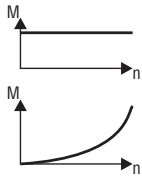

\*) applies to  $f_{PWM} = 4$  kHz

**To provide sufficient cooling leave a minimum clearance of 100 mm (4 in) above and below each unit.**

Power ratings are based on a default setting of 4 kHz for the PWM frequency (P325/P345).

For  $V_{mains} = 3 \times 500 V_{AC}$  the permissible input and output currents are reduced by 20 % compared to the rated values.

5.3.5 Basic units, size 4

MOVITRAC® 31C		300-503-4-00	370-503-4-00	450-503-4-00
Part number		826 329 9	826 330 2	826 331 0
<b>INPUT</b>				
Input voltages Permissible range	$V_{in}$	3 x 380 V <sub>AC</sub> / 400 V <sub>AC</sub> / 415 V <sub>AC</sub> / 460 V <sub>AC</sub> / 480 V <sub>AC</sub> / 500 V <sub>AC</sub> $V_{in} = 380V_{AC} - 10\% \dots 500V_{AC} + 10\%$		
Input frequency	$f_{in}$	50 Hz ... 60 Hz ± 5%		
Rated input current (at $V_{in} = 3 \times 400V_{AC}$ )	$I_{in}$ 100% 125%	56 A <sub>AC</sub> 70 A <sub>AC</sub>	69 A <sub>AC</sub> 86 A <sub>AC</sub>	84 A <sub>AC</sub> 105 A <sub>AC</sub>
<b>OUTPUT</b>				
Rated output power (at $V_{in} = 3 \times 380 \dots 500V_{AC}$ )	$P_N$	42 kVA	52 kVA	64 kVA
Rated output current (at $V_{in} = 3 \times 400V_{AC}$ )	$I_N$	61 A <sub>AC</sub>	75 A <sub>AC</sub>	92 A <sub>AC</sub>
Cont. output current = 125% $I_N^*$ (at $V_{in} = 3 \times 400V_{AC}$ )	$I_{cont}$	76 A <sub>AC</sub>	93 A <sub>AC</sub>	115 A <sub>AC</sub>
Constant load Recommended motor power	$P_{Mot}$	30 kW (40 HP)	37 kW (50 HP)	45 kW (60 HP)
Variable torque load and constant load without overload Recommended motor power	$P_{Mot}$	37 kW (50 HP)	45 kW (60 HP)	55 kW (75 HP)
Current limit	$I_{max}$	Motive: 150% $I_N$ Regenerative: 150% $I_N$ Duration depending on utilization		
Internal current limit		$I_{max} = 20 \dots 150\%$ set via menu (P320 / P340)		
Minimum braking resistance value for 4-Q operation	$R_{BW}$	12 Ω -10%	10 Ω -10%	8.2 Ω -10%
Output voltage	$V_{out}$	Adjustable with parameter P329/P349, however max. $V_{in}$		
Output frequency resolution base frequency	$f_{out}$ $\Delta f_{out}$ $f_{base}$	0...400 Hz, $f_{min} = 0 \dots 40$ Hz, $f_{max} = 5 \dots 400$ Hz 0.05 Hz over the entire range In steps: 50/60/87/104/120 Hz and continuously: 5...400 Hz		
PWM frequency	$f_{PWM}$	Adjustable: 4/8/12/16 kHz (P325/P345)		
<b>GENERAL</b>				
Power losses at $P_N$	$P_{lossmax}$	1000 W	1200 W	1500 W
Cooling method (DIN 41751) fan cooling forced cooling/required air flow		230 m <sup>3</sup> /h (135 ft <sup>3</sup> /min)		
Weight		19 kg (41.9 lb)		20 kg (44.1 lb)
Dimensions	W×H×D	220 × 555 × 264 mm (8.66 × 21.85 × 10.39 in)		

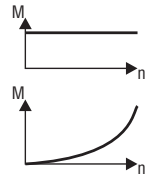

\*) applies to  $f_{PWM} = 4$  kHz

**To provide sufficient cooling leave a minimum clearance of 100 mm (4 in) above and below each unit.**

Power ratings are based on a default setting of 4 kHz for the PWM frequency (P325/P345).

For  $V_{mains} = 3 \times 500 V_{AC}$  the permissible input and output currents are reduced by 20 % compared to the rated values.

## 5.4 MOVITRAC® 31C electronics data

MOVITRAC® 31C		General electronic data	
Voltage supply for setpoint input	X2:31	+10V <sub>DC</sub> +5%/-0%, I <sub>max</sub> = 3mA Reference voltages for setpoint pot.	
Setpoint input n2	X2:34 X2:35	n2 = 0...+10V / -10V...+10V Resolution: 9 Bit $\Delta$ 20 mV, sample time: 5 ms R <sub>i</sub> = 40k $\Omega$ (external voltage supply) R <sub>i</sub> = 20k $\Omega$ (supplied by X2:31)	n2 = 0...20 mA / 4...20 mA Resolution: 8 Bit $\Delta$ 0.08 mA Sample time: 5 ms
Internal setpoints		n11/n12/n13 or n21/n22/n23 = 0...400 Hz	
Frequency ramp generator time ranges at $\Delta f_{out} = 50$ Hz		1. ramp t11/t21 up: 0.0...2000 s down: 0.0...2000 s 2. ramp t12/t22 up/down: 0.0...2000 s Rapid stop Ramp t13/t23 down: 0...9.95 s Motor. pot. t4 up: 2...60 s down: 2...60 s	
Auxiliary voltage output		V = 24 V <sub>DC</sub> , current rating I <sub>max</sub> = 250 mA	
External voltage supply		V <sub>N</sub> = 24 V <sub>DC</sub> -15% / +20% (range 19.2...30 V <sub>DC</sub> ) According to EN 61131-2 Basic unit without options: I <sub>E</sub> <sup>a</sup> 200 mA Basic unit with options: I <sub>E_max</sub> <sup>a</sup> 600 mA	
Binary inputs		Electrically isolated via opto-coupler (EN 61131-2) R <sub>i</sub> $\approx$ 3.0 k $\Omega$ I <sub>E</sub> $\approx$ 10 mA	sample time: 5 ms SPS compatible
Signal level		+13...+30 V $\Delta$ "1" = contact closed -3...+5 V $\Delta$ "0" = contact open	According to EN 61131-2
Control functions	X2:41 X3:42/43/47/X14:48/49	Fixed assigned to "CW/stop" → menu P60_	
Binary outputs		R <sub>i</sub> $\approx$ 100 $\Omega$	SPS compatible, response time: 5 ms
Signal level		"0" = 0 V "1" = 24 V	<b>Important:</b> Do not apply an external voltage!
Control functions	X3:61 X3:62	Binary output fixed assigned to "/Brake", I <sub>max</sub> = 150mA (short-circuit proof) Binary output → menu P61_, I <sub>max</sub> = 50mA (short-circuit proof)	
Measurement output		R <sub>i</sub> $\approx$ 330 $\Omega$ , I <sub>max</sub> = 3 mA, sample time: 10 ms, max.cable length: 10 m (33 ft)	
Signal level		5 V-TTL, PWM pulsed with 100 Hz	
Control functions	X2:65	Measurement output → menu P634	
Reference terminals	X2:0 0V10 X3:30/X14:30 0V24 X3:60/X14:60 Bezug	Reference potential for analog signals and terminal X2:31 Reference potential for binary signals Reference for binary inputs X3:41/42/43/47 and X14:48/49	
Permissible cable section		Single core: 0.20...2.5 mm <sup>2</sup> (AWG24...12) Double core: 0.20...1 mm <sup>2</sup> (AWG24...17)	

## 6 Index

### A

- Assignment of braking resistors, chokes and filters
  - 230 V units 15
  - 400/500 V units 16

### C

- Connection
  - FEA31C option 21
  - FEN31C/FPI31C option 23
  - FIO31C option 22
  - FIT31C option 24
  - Incremental encoder 25
  - Power section and brake 12
  - Processor card 13
  - RS-232 serial interface 19
  - RS-485 serial interface 19

### D

- Display messages 50

### F

- Fault information
  - Fault memory 51
  - Reset 51
  - Switch-off responses 51
- Fault signals 52

### I

- Immediate switch-off 51
- Installation
  - EMC compliant 10
  - Instructions 9
  - Size 0 with braking resistor 18
  - UL compliant 11

### K

- Keypad
  - Basic displays 47
  - Functions 48
  - Selecting a language 27
  - Short menu 49
  - Startup functions 27

### N

- Nameplate 5

### O

- Operating displays
  - Keypad 47
  - LED display 47
- Option label 5

### P

- Parameter list
  - 0\_ Display values 39
  - 1\_ Setpoints / Ramp generators 40
  - 2\_ Frequency characteristics 41
  - 3\_ Motor parameters 41
  - 4\_ Reference signals 42
  - 5\_ Monitoring functions 43
  - 6\_ Terminal assignment 44
  - 7\_ Control functions 45
  - 8\_ Special functions 46

### R

- Rapid stop 51
- RESET 51

### S

- Service
  - Service label 55
  - Submitting for service 55
- Speed controller
  - Connection of FEN31C speed detection 23
  - Incremental encoder connection 25
  - Startup 38
- Starting the motor
  - Manual operation 31
  - with analog setpoints 29
  - with fixed setpoints 30
- Startup
  - Examples
    - Example values for Boost and IxR 33
    - Hoist drives 37
    - Notes and presettings 32
    - Travel drive, group drive, pump or fan drive 36
  - FRN31C / FEN31C speed controller 38
  - Preliminary work and aids 26
  - Selecting a language on the keypad 27
  - Short-cut startup procedure 28

### T

- Technical data
  - 230 V units
    - Sizes 0 and 1 57
  - 400/500 V units
    - Size 0 59
    - Size 1 60
    - Size 2 61
    - Size 3 62
    - Size 4 63
  - Electronics data 64
  - General technical data 56
- Type designation 5

ét. :				
<b>Germany</b>	<b>Headquarters Manufacture Sales, Service</b>	<b>Bruchsal</b>	SEW-EURODRIVE GmbH & Co Ernst-Blickle-Straße 42 D-76646 Bruchsal Postfach 3023, D-76642 Bruchsal	Tel. (0 72 51) 75-0 Telefax (0 72 51) 75-19 70 Telex 7 822 391 <a href="http://www.SEW-EURODRIVE.com">http://www.SEW-EURODRIVE.com</a> sew @ sew-eurodrive.com
	<b>Manufacture</b>	<b>Graben</b>	SEW-EURODRIVE GmbH & Co Ernst-Blickle-Straße 1 D-76676 Graben-Neudorf Postfach 1220, D-76671 Graben-Neudorf	Tel. (0 72 51) 75-0 Telefax (0 72 51) 75-29 70 Telex 7 822 276
	<b>Assembly Service</b>	<b>Garbsen (near Hannover)</b>	SEW-EURODRIVE GmbH & Co Alte Ricklinger Straße 40-42 D-30823 Garbsen Postfach 110453, D-30804 Garbsen	Tel. (0 51 37) 87 98-30 Telefax (0 51 37) 87 98-55
		<b>Kirchheim (near München)</b>	SEW-EURODRIVE GmbH & Co Domagkstraße 5 · D-85551 Kirchheim	Tel. (0 89) 90 95 52-10 Telefax (0 89) 90 95 52-50
		<b>Langenfeld (near Düsseldorf)</b>	SEW-EURODRIVE GmbH & Co Siemensstraße 1, D-40764 Langenfeld	Tel. (0 21 73) 85 07-30 Telefax (0 21 73) 85 07-55
		<b>Meerane (near Zwickau)</b>	SEW-EURODRIVE GmbH & Co Dänkritzer Weg 1, D-08393 Meerane	Tel. (0 37 64) 76 06-0 Telefax (0 37 64) 76 06-30
<b>France</b>	<b>Headquarters Manufacture Service</b>	<b>Haguenau</b>	SEW-USOCOME S.A. 48-54, route de Soufflenheim B. P.185 F-67506 Haguenau Cedex	Tel. 03 88 73 67 00 Telefax 03 88 73 66 00 Telex: 870 033 <a href="http://www.usocome.com">http://www.usocome.com</a> sew@usocome.com
	<b>Manufacture</b>	<b>Forbach</b>	SEW-EURODRIVE S.A. Zone industrielle Technopole Forbach Sud B. P. 30269, F-57604 Forbach Cedex	
	<b>Assembly Service Technical Offices</b>	<b>Bordeaux</b>	SEW-USOCOME Parc d 'activités de Magellan 62, avenue de Magellan - B. P.182 F-33607 Pessac Cedex	Tel. 05 57 26 39 00 Telefax 05 57 26 39 09
		<b>Paris</b>	SEW-USOCOME Zone industrielle, 2, rue Denis Papin F-77390 Verneuil l' Etang	Tel. 01 64 42 40 80 Telefax 01 64 42 40 88
<b>Australia</b>	<b>Assembly Sales, Service</b>	<b>Melbourne</b>	SEW-EURODRIVE PTY. LTD. 27 Beverage Drive Tullamarine, Victoria 3043	Tel. (03) 93 38-79 11 Telefax (03) 93 30-32 31 + 93 35 35 41
		<b>Sydney</b>	SEW-EURODRIVE PTY. LTD. 9, Sleigh Place, Wetherill Park Sydney N. S. W. 2164	Tel. (02) 97 56 10 55 Telefax (02) 97 56 10 05
<b>Austria</b>	<b>Assembly Sales, Service</b>	<b>Wien</b>	SEW-EURODRIVE Ges.m.b. H. Richard-Strauss-Straße 24 A-1230 Wien	Tel. (01) 6 17 55 00-0 Telefax (01) 6 17 55 00-30
<b>Belgium</b>	<b>Assembly Sales, Service</b>	<b>Bruxelles</b>	CARON-VECTOR S.A. Avenue Eiffel 5 B-1300 Wavre	Tel. (010) 23 13 11 Telefax (010) 23 13 36 <a href="http://www.caron-vector.be">http://www.caron-vector.be</a> info@caron-vector.be
<b>Brazil</b>	<b>Manufacture Sales, Service</b>	<b>São Paulo</b>	SEW DO BRASIL Motores-Redutores Ltda. Caixa Postal 201-0711-970 Rodovia Presidente Dutra km 213 CEP 07210-000 Guarulhos-SP	Tel. (011) 64 60-6433 Telefax (011) 64 80-43 43 E-Mail: sew.brasil@originet.com.br
<b>Canada</b>	<b>Assembly Sales, Service</b>	<b>Toronto</b>	SEW-EURODRIVE CO. OF CANADA LTD. 210 Walker Drive, Bramalea, Ontario L6T3W1	Tel. (905) 7 91-15 53 Telefax (905) 7 91-29 99
		<b>Vancouver</b>	SEW-EURODRIVE CO. OF CANADA LTD. 7188 Honeyman Street, Delta. B.C. V4G 1 E2	Tel. (604) 2 72 42 88 + 9 46 55 35 Telefax (604) 946-2513
		<b>Montreal</b>	SEW-EURODRIVE CO. OF CANADA LTD. 2555 Rue Leger Street LaSalle, Quebec H8N 2V9	Tel. (514) 3 67-11 24 Telefax (514) 3 67-36 77
<b>Chile</b>	<b>Assembly Sales, Service</b>	<b>Santiago de Chile</b>	SEW-EURODRIVE CHILE Motores-Redutores LTDA. Panamericana Norte N° 9261 Casilla 23-Correo Quilicura RCH-Santiago de Chile	Tel. (02) 6 23 82 03 + 6 23 81 63 Telefax (02) 6 23 81 79
<b>China</b>	<b>Manufacture Assembly Sales, Service</b>	<b>Tianjin</b>	SEW-EURODRIVE (Tianjin) Co., LTD No. 46, 7th Avenue, TEDA Tianjin 300457	Tel. (022) 25 32 26 12 Telefax (022) 25 32 26 11
<b>Denmark</b>	<b>Assembly Sales, Service</b>	<b>Kopenhagen</b>	SEW-EURODRIVE A/S Geminivej 28-30, P.O. BoX 100 DK-2670 Greve	Tel. 4395 8500 Telefax 4395 8509
<b>Finland</b>	<b>Assembly Sales, Service</b>	<b>Lahti</b>	SEW-EURODRIVE OY Vesimäentie 4, FIN-15860 Hollola2	Tel. (3) 58 93 00 Telefax (3) 7 80 62 11
<b>Great Britain</b>	<b>Assembly Sales, Service</b>	<b>Normanton</b>	SEW-EURODRIVE Ltd. Beckridge Industrial Estate P.O. Box No.1 GB-Normanton, West-Yorkshire WF61 QR	Tel.19 24 89 38 55 Telefax 19 24 89 37 02
<b>Hong Kong</b>	<b>Assembly Sales, Service</b>	<b>Hong Kong</b>	SEW-EURODRIVE LTD. Unit No.801-806, 8th Floor Hong Leong Industrial Complex No. 4, Wang Kwong Road Kowloon, Hong Kong	Tel. 2-7 96 04 77 + 7 96 04 65 Telefax 2-795-91 29



## Service and spare parts



<b>Italy</b>	<b>Assembly Sales, Service</b>	<b>Milano</b>	SEW-EURODRIVE di R. Blickle & Co. s.a.s. Via Bernini, 14, I-20020 Solaro (Milano)	Tel. (02) 96 79 97 71 Telefax (02) 96 79 97 81
<b>Japan</b>	<b>Assembly Sales, Service</b>	<b>Toyoda-cho</b>	SEW-EURODRIVE JAPAN CO., LTD. 250-1, Shimoman-no, Toyoda-cho, Iwata-gun Shizuoka prefecture, P.O. Box 438-0818	Tel. (053 83) 7 38 11-13 Telefax (053 83) 7 38 14
<b>Korea</b>	<b>Assembly Sales, Service</b>	<b>Ansan</b>	SEW-EURODRIVE CO., LTD. B 601-4, Banweol Industrial Estate 1048-4, Shingil-dong, Ansan 425-120	Tel. (031) 4 92-80 51 Telefax (031) 4 92-80 56 + 4 91 62 47
<b>Malaysia</b>	<b>Assembly Sales, Service</b>	<b>Johore</b>	SEW-EURODRIVE Sdn. Bhd. 95, Jalan Seroja 39 81100 Johore Bahru, Johore	Tel. (07) 3 54 57 07 + 3 54 94 09 Telefax (07) 3 5414 04
<b>Netherlands</b>	<b>Assembly Sales, Service</b>	<b>Rotterdam</b>	VECTOR Aandrijftechniek B.V. Industrieweg 175 NL-3044 AS Rotterdam Postbus 10085, NL-3004 AB Rotterdam	Tel. (010) 4 46 37 00 Telefax (010) 4 15 55 52
<b>New Zealand</b>	<b>Assembly Sales, Service</b>	<b>Auckland</b>	SEW-EURODRIVE NEW ZEALAND LTD. P.O. Box 58-428 82 Greenmount Drive, East Tamaki, Auckland	Tel. (09) 2 74 56 27 2 74 00 77 Telefax (09) 2 74 01 65
<b>Norway</b>	<b>Assembly Sales, Service</b>	<b>Moss</b>	SEW-EURODRIVE A/S Solgaard skog 71, N-1539 Moss	Tel. (69) 24 10 20 Telefax (69) 24 10 40
<b>Portugal</b>	<b>Assembly Sales, Service</b>	<b>Coimbra</b>	SEW-EURODRIVE, LDA. Apartado 15, 3050 Mealhada	Tel. (231) 20 96 70 Telefax (231) 20 36 85
<b>Singapore</b>	<b>Assembly Sales, Service</b>	<b>Singapore</b>	SEW-EURODRIVE PTE. LTD. No 9, Tuas Drive 2, Jurong Industrial Estate Singapore 638644 Jurong Point Post Office, P.O. Box 813 Singapore 916428	Tel. 86 21 701-705 Telefax 8 61 28 27 Telex: 38 659
<b>South Africa</b>	<b>Assembly Sales, Service</b>	<b>Johannesburg</b>	SEW-EURODRIVE (PROPRIETARY) LIMITED Eurodrive House Cnr. Adcock Ingram and Aerodrome Roads Aeroton Ext. 2, Johannesburg 2013 P.O. Box 27032, 2011 Benrose, Johannesburg	Tel. (2711) 4 94 43 80 Telefax (2711) 4 94 23 00
		<b>Capetown</b>	SEW-EURODRIVE (PROPRIETARY) LIMITED Rainbow Park Cnr. Racecourse & Omuramba Road Montague Gardens, 7441 Cape Town P.O.Box 53 573 Racecourse Park, 7441 Cape Town	Tel. (021) 5 11 09 87 Telefax (021) 5 11 44 58 Telex: 576 062
		<b>Durban</b>	SEW-EURODRIVE (PROPRIETARY) LIMITED 39 Circuit Road, Westmead, Pinetown P.O. Box 10433, Ashwood 3605	Tel. (031) 7 00 34 51 Telex: 622 407
<b>Spain</b>	<b>Assembly Sales, Service</b>	<b>Bilbao</b>	SEW-EURODRIVE ESPAÑA, S.L. Parque Tecnológico, Edificio, 302 E-48170 Zamudio (Vizcaya)	Tel. 9 44 31 84 70 Telefax 9 44 31 84 71 sew.spain@sew-eurodrive.es
<b>Sweden</b>	<b>Assembly Sales, Service</b>	<b>Jönköping</b>	SEW-EURODRIVE AB Gnejsvägen 6-8 S-55303 Jönköping	Tel. (036) 16 50 70 Telefax (036) 16 44 69 Telex: 70162
<b>Switzerland</b>	<b>Assembly Sales, Service</b>	<b>Basel</b>	Alfred Imhof A.G. Jurastrasse 10 CH-4142 Münchenstein bei Basel	Tel. (061) 4 17 17 17 Telefax (061) 4 17 17 00 www.imhof-sew.ch/info@imhof-sew.ch
<b>Thailand</b>	<b>Assembly</b>	<b>Chon Buri</b>	SEW-EURODRIVE (Thailand) Ltd. Bangpakong Industrial Park 2 700/456, M007, Tambol Bonhuroh Muang District, Chon Buri 20000	Tel. 0066-38 21 45 29/30 Telefax 0066-38 21 45 31
<b>Turkey</b>	<b>Assembly Sales, Service</b>	<b>Istanbul</b>	SEW-EURODRIVE Hareket Sistemleri Ticaret Ltd. Sirketi Bagdat Cad. Koruma Cikmazi No. 3 TR-81540 Maltepe ISTANBUL	Telefon (216) 4 41 91 63 + 4 41 91 64 + 3 83 80 14 + 3 83 80 15 Telefax (216) 3 05 58 67
<b>USA</b>	<b>Manufacture Assembly Sales, Service</b>	<b>Greenville</b>	SEW-EURODRIVE INC. 1295 Old Spartanburg Highway P.O. Box 518 Lyman, S.C. 29365	Tel. (864) 4 39-75 37 Telefax Sales (864)439-78 30 Telefax Man. (864) 4 39-99 48 Telefax Ass. (864) 4 39-05 66 Telex: 805 550
		<b>San Francisco</b>	SEW-EURODRIVE INC. 30599 San Antonio Road P.O. Box 3910, Hayward California 94544	Tel. (510) 4 87-35 60 Telefax (510) 4 87-63 81
	<b>Assembly Sales, Service</b>	<b>Philadelphia/PA</b>	SEW-EURODRIVE INC. Pureland Ind. Complex 200 High Hill Road, P.O. Box 481 Bridgeport, New Jersey 08014	Tel. (609) 4 67-22 77 Telefax (609) 8 45-31 79
		<b>Dayton</b>	SEW-EURODRIVE INC. 2001 West Main Street Troy, Ohio 45373	Tel. (513) 3 35-00 36 Telefax (513) 2 22-41 04 Telex: 6 874 204
		<b>Dallas</b>	SEW-EURODRIVE INC. 3950 Platinum Way, Dallas, Texas 75237	Tel. (214) 3 30-48 24 Telefax (214) 3 30-47 24
<b>Venezuela</b>	<b>Assembly Sales, Service</b>	<b>Valencia</b>	SEW-EURODRIVE Venezuela S.A. Av. Norte Sur No. 3, Galpon 84-319 Zona Industrial Municipal Norte Valencia	Tel. (041) 32 95 83 Telefax (041) 38 62 75 sewventas@cantv.net

**We are available, wherever you need us.  
Worldwide.**

SEW-EURODRIVE right around the globe is  
your competent partner in matters of power

transmission with manufacturing and assem-  
bly plants in most major industrial countries.



**SEW  
EURODRIVE**

SEW-EURODRIVE GmbH & Co · P.O.Box 30 23 · D-76642 Bruchsal/Germany  
Tel. +49-7251-75-0 · Fax +49-7251-75-19 70 · Telex 7 822 391  
<http://www.SEW-EURODRIVE.com> · [sew@sew-eurodrive.com](mailto:sew@sew-eurodrive.com)