

MAC AC Servo Motors

Project Planning Manual

DOK-MOTOR*-MAC*****-PRJ1-EN-P



| | |
|------------------------------------|---|
| Title | MAC AC Servo Motors |
| Type of Documentation | Project Planning |
| Document number | 209-0040-4356-00 |
| Internal file reference | Mappe 5 |
| Replaces | 9.552.136.4-03 9.552.137.4-03 9.552.138.4-03 9.552.140.4-03 9.552.141.4-04 9.552.143.4-02 |
| The purpose of this documentation? | This project planning documentation <ul style="list-style-type: none">• lists the technical data and power features of the motor• offers guidelines on the mechanical integration of the motor into the machine• offers guidelines on the electrical integration of the motor into the machine• outlines the available options• lists the order information for motor and its electrical connecting accessories• offers guidelines on the transport, handling and storage of motors. |
| Copyright | © INDRAMAT GmbH, 1996 Copying this document, and giving it to others and the use or communication of the contents thereof without express authority, are forbidden. Offenders are liable for the payment of damages. All rights are reserved in the event of the grant of a patent or the registration of a utility model or design (DIN 34-1). |
| Published by | INDRAMAT GmbH, Dept. ENA |
| Validity | All rights are reserved with respect to the content of this documentation and the availability of the product. |

Table of Contents

Page

| | |
|--|-----------|
| 1. MAC AC Servo Motors | 7 |
| 2. Technical Explanations | 12 |
| 2.1. Ambient Conditions | 12 |
| 2.2. Mechanical Features | 15 |
| 2.3. Electrical Features | 22 |
| 2.4. Motor Feedback | 25 |
| 2.4.1. Tachofeedback | 25 |
| 2.4.2. Tachofeedback and Second Shaft End | 26 |
| 2.4.3. Tachofeedback with Mounted Encoder | 27 |
| 2.4.4. Incremental Encoder | 28 |
| 2.4.5. Absolute Encoder | 34 |
| 2.5. Torque-Speed Characteristics | 39 |
| 3. MAC 063 | 42 |
| 3.1. Technical Data | 42 |
| 3.2. Torque-Speed Characteristics | 44 |
| 3.3. Shaft Load Capacity | 47 |
| 3.4. Dimensional Data - Natural Convection | 48 |
| 3.5. Dimensional Data - Radial Cooling | 51 |
| 3.6. Dimensional Data - Axial Cooling | 54 |
| 3.7. Available Options | 56 |
| 3.8. Special Options | 57 |
| 4. MAC 071 | 59 |
| 4.1. Technical Data | 59 |
| 4.2. Torque-Speed Characteristics | 61 |
| 4.3. Shaft Load Capacity | 67 |
| 4.4. Dimensional Data - Natural Convection | 68 |
| 4.5. Dimensional Data - Radial Cooling | 71 |
| 4.6. Dimensional Data - Axial Cooling | 74 |
| 4.7. Available Options | 77 |
| 4.8. Special Options | 78 |
| 5. MAC 090 | 80 |
| 5.1. Technical Data | 80 |

| | | |
|-----------|---|------------|
| 5.2. | Torque-Speed Characteristics | 82 |
| 5.3. | Shaft Load Capacity | 85 |
| 5.4. | Dimensional Data - Natural Convection | 86 |
| 5.5. | Dimensional Data - Radial Cooling | 89 |
| 5.6. | Dimensional Data - Axial Cooling | 92 |
| 5.7. | Available Options | 95 |
| 5.8. | Special Options | 96 |
| 6. | MAC 093 | 97 |
| 6.1. | Technical Data | 97 |
| 6.2. | Torque-Speed Characteristics | 99 |
| 6.3. | Shaft load Capacity | 105 |
| 6.4. | Dimensional Data - Natural convection | 106 |
| 6.5. | Dimensional Data - Radial Cooling | 109 |
| 6.6. | Dimensional Data - Axial Cooling | 112 |
| 6.7. | Available Options | 115 |
| 6.8. | Special Options | 116 |
| 7. | MAC 112 | 118 |
| 7.1. | Technical Data | 118 |
| 7.2. | Torque-Speed Characteristics | 120 |
| 7.3. | Shaft load Capacity | 125 |
| 7.4. | Dimensional Data - Natural convection | 126 |
| 7.5. | Dimensional Data - Radial Cooling | 129 |
| 7.6. | Dimensional Data - Axial Cooling | 132 |
| 7.7. | Available Options | 135 |
| 7.8. | Special Options | 136 |
| 8. | MAC 115 | 137 |
| 8.1. | Technical Data | 137 |
| 8.2. | Torque-Speed Characteristics | 139 |
| 8.3. | Shaft load Capacity | 143 |
| 8.4. | Dimensional Data - Natural convection | 144 |
| 8.5. | Dimensional Data - Radial Cooling | 147 |
| 8.6. | Dimensional Data - Axial Cooling | 150 |
| 8.7. | Available Options | 153 |
| 8.8. | Special Options | 154 |

| | | |
|------------|---|------------|
| 9. | Electrical Power Connection | 155 |
| 9.1. | Terminal Diagram | 155 |
| 9.2. | Connector to Cable Allocations | 156 |
| 9.3. | Power Connector (Motor Power Connector) | 162 |
| 9.4. | Motor Power Cable | 163 |
| 9.4.1. | Technical Data | 163 |
| 9.4.2. | General Data | 163 |
| 9.4.3. | Ready-made Motor Power Cables | 164 |
| 9.4.4. | Order guidelines | 169 |
| 10. | Electrical Connection Tachofeedback | 170 |
| 10.1. | Terminal Diagram | 170 |
| 10.2. | Tachofeedback Connector | 170 |
| 10.3. | Tachofeedback Cable | 171 |
| 10.3.1. | Technical Data | 171 |
| 10.3.2. | Ready-Made Tachofeedback Cable | 172 |
| 10.3.3. | Order guidelines | 172 |
| 11. | Electrical Connection Incremental Encoder | 173 |
| 11.1. | Terminal Diagram | 173 |
| 11.2. | Incremental Encoder Connector | 174 |
| 11.3. | Incremental Encoder Cable | 174 |
| 11.3.1. | Technical Data | 174 |
| 11.3.2. | Ready-Made Incremental Encoder Cable for Encoders with Square-Wave Pulses | 175 |
| 11.3.3. | Order guidelines | 175 |
| 12. | Electrical Connection Absolute Encoder | 176 |
| 12.1. | Terminal Diagram | 176 |
| 12.2. | Absolute Encoder Connector | 176 |
| 12.3. | Absolute Encoder Cable | 177 |
| 12.3.1. | Technical Data | 177 |
| 12.3.2. | Ready-Made Absolute Encoder Cables | 178 |
| 12.3.3. | Order guidelines | 178 |
| 13. | Guidelines on Cable Routing | 179 |
| 14. | Condition at Delivery | 180 |
| 15. | Identifying the Merchandise | 181 |

| | |
|---|------------|
| 16. Storage, Transport and Handling | 183 |
| 17. Mounting and Installation Guidelines | 186 |
| 18. Service Notes | 187 |
| 18.1. Contacting Customer Service | 187 |
| 18.2. Repair Card | 188 |

1. MAC AC Servo Motors

Applications AC servo motors of the MAC series are rapid-response servo drives in conjunction with TDM, KDS and DSC drive controllers. They are especially well-suited for use in:

- machine tools,
- textile machines,
- printing presses,
- packaging machinery,
- robotics,
- handling equipment and
- transfer facilities.

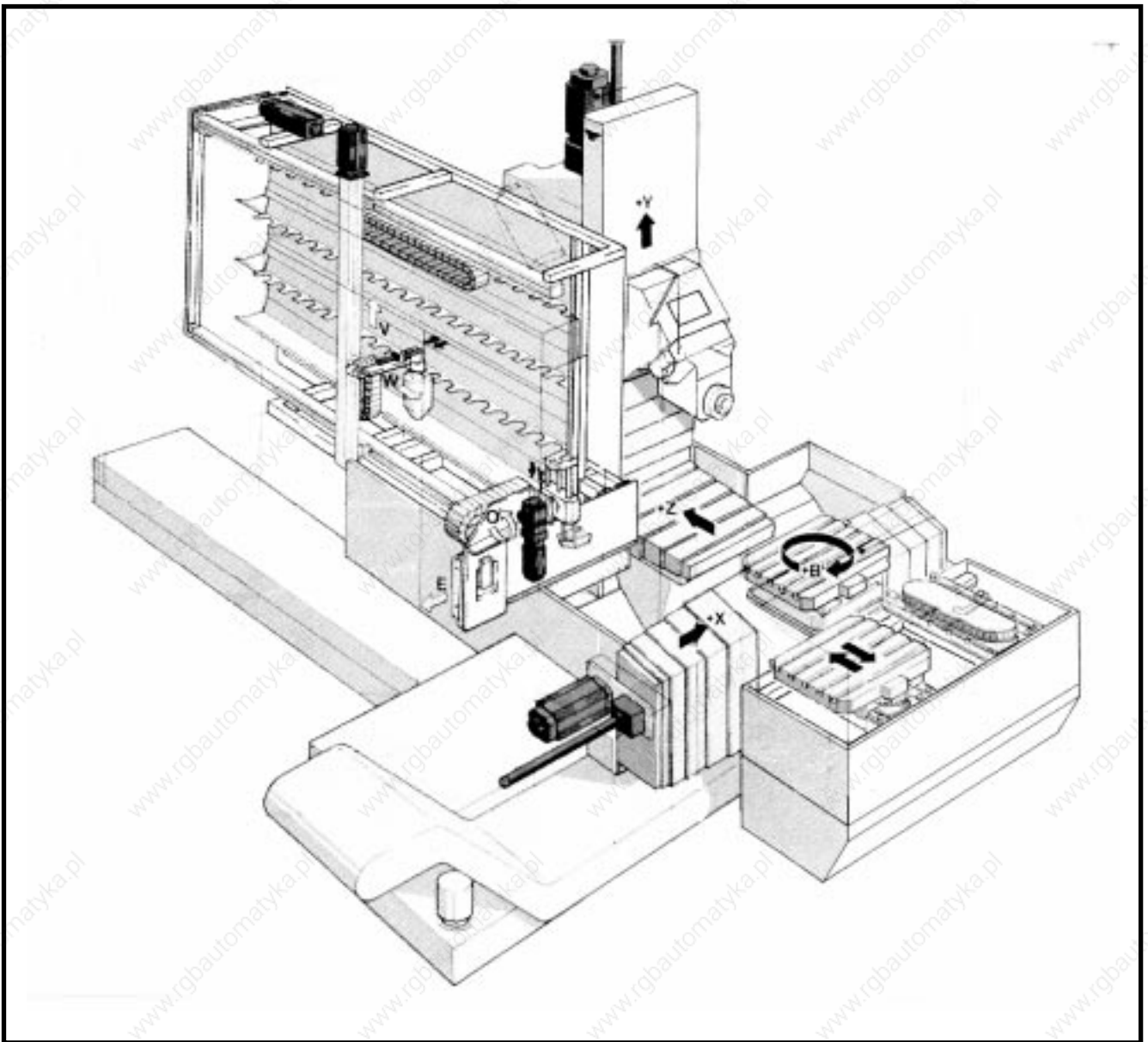

Fig 1.1: Applications example: a machining center with four axes with tool and workpiece handling facilities

Overview of power ratings

Figure 1.2 illustrates the available motor line with the power features, "continuous torque at standstill M_{dN} " and "nominal speed n ".

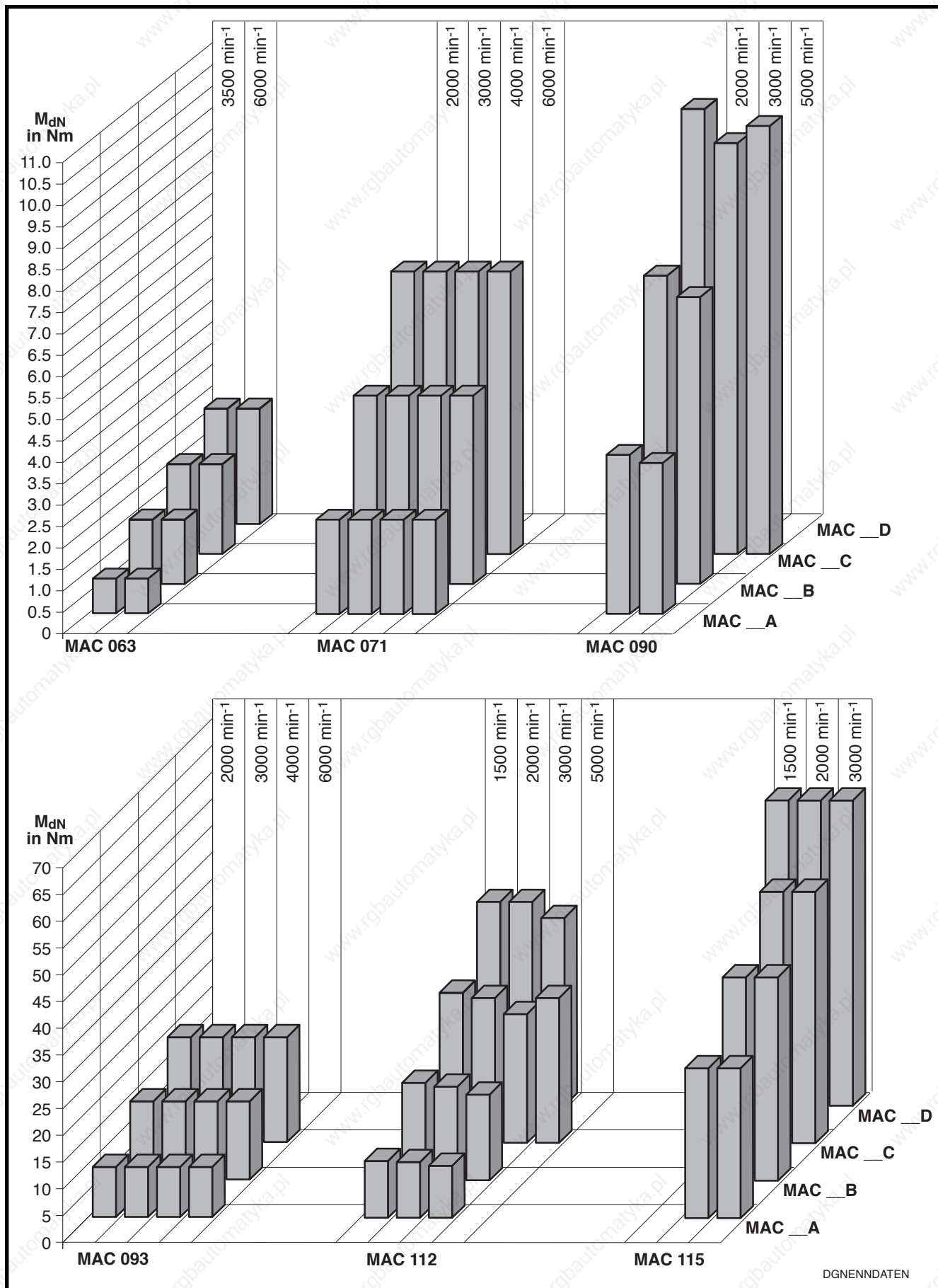

Fig 1.2: Power ratings

Construction and components of the motor

MAC AC servo motors are permanent magnet-excited motors with electronic commutation. The permanent magnets of the rotor are made up of materials which make it possible to construct motors with very low inertia.

Figure 1.3 illustrates the basic construction and components of a MAC AC servo motor.

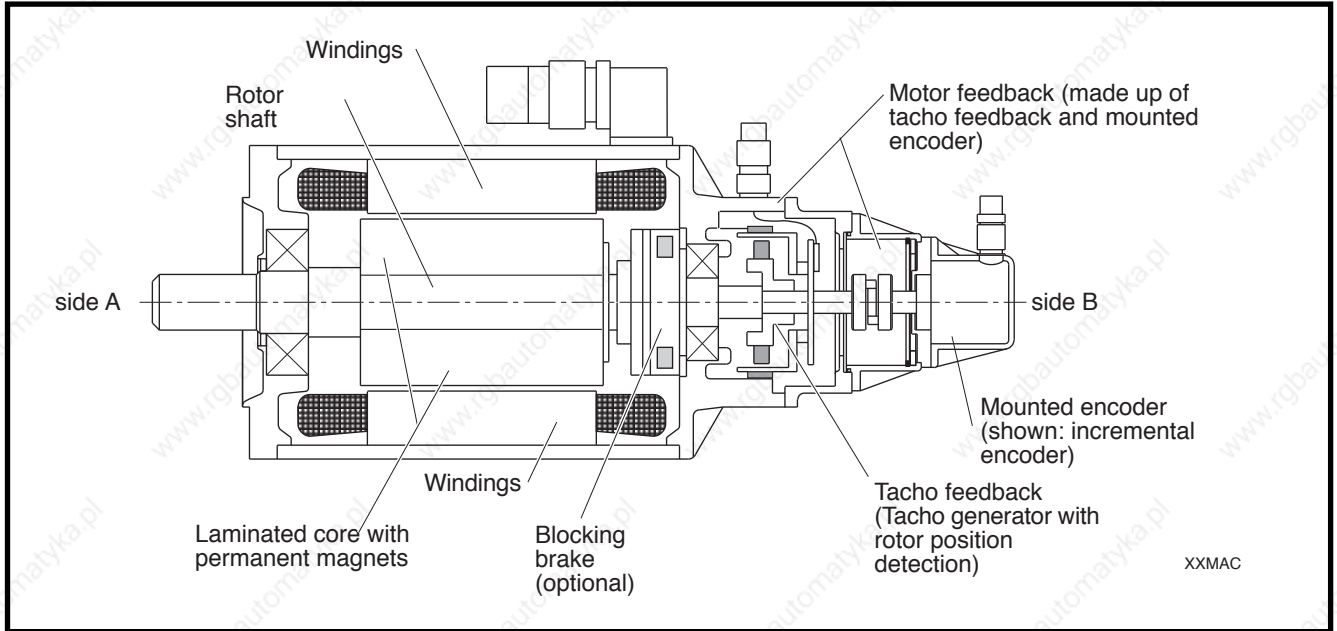

Fig 1.3: The structure of a MAC AC servo motor

Motor feedback

The motor feedback of a MAC AC servo motor is always made up of one tachofeedback. The motor can also be additionally equipped with a mounted encoder for position evaluation.

Tachofeedback

For speed evaluation per tacho-generator and rotor position recognition, the motors are equipped with a tachofeedback especially developed for this series. It is always integrated into the motor.

Mounted encoder

For position evaluation on the motor, the motor can also be equipped with:

- a second shaft end to mount the customer's own encoders,
- an incremental encoder and
- an absolute encoder.

- Operating reliability** MAC motors achieve a **high degree of reliability** as a result of the following structural features:
- Maintenance-free operation due to:
 - the brushless design of the motor and
 - the use of life-time lubricated bearings.
 - Can be used directly within the working area of the machine even under poor environmental conditions such as affects of coolants, soluble oil emulsions and so on:
 - because the motor housing is totally enclosed as per protection category IP 65
 - because the motor power and tachofeedback cables as well as the encoder cables are designed to meet IP 65 demands.
 - Motor temperature is monitored with thermo switches integrated into the motor windings and stator housing. This prevents overload damage.
- Output data** The **output data of the motor is high**. This is described in detail as follows:
- High dynamic performance due to favorable torque-inertia ratio.
 - A high overload capacity of the motor as the heat is dissipated from the stator windings to the outside wall of the motor housing.
 - Utilization of peak torque over a wide speed range.
 - High power to weight ratio due to compact construction.
 - High cyclic load capacity permits continuous start-stop operations with high repetition rates due to electronic commutation of the motor.
 - Excellent smooth running qualities resulting from the special design of the stator and high-resolution tachofeedback.
- Installation on the machine** **Mounting** the motor to the machine **is simple**.
- Pinions and belt pulleys can be directly mounted onto the shaft because the design of the bearing assembly makes the application of high radial loads possible.
 - There is a defined assimilation of outside forces at the motor shaft. This means that the floating bearing of side A of the motor absorbs the radial forces. Side B absorbs the axial forces.
 - Thermal deformations affect side A.
 - The motor can be mounted in any orientation.
 - Flange design with throughholes in the flange makes it possible to mount as per design IM B5 or with windings in the flange as per design IM B14.
 - A variety of ready-made cables is available, eliminating additional installation work.
- Cooling** The MAC AC servo motors are available with surface cooling for extreme loads. An overview of the blower options for the individual series is offered in Section 2.2, Figure 2.11.

- Holding brake** MAC motors can be delivered with or without holding brakes.
 The holding brake makes it possible to clamp (hold into place) the output shaft at standstill. This achieves a safe standstill of the axis even when power is off.
- Output shaft** The output shaft is available in two different designs:
- as a plain shaft for non-positive shaft-hub connections and
 - shafts with keyways for form-fitting shaft-hub connections.
- Smooth run** The MAC 090 and 112 AC servo motors are available with a special windings design which achieves a high degree of smooth run. It is particularly well-suited for use in grinding machines and precision lathes.
 It must be designated in type code field 5 with a "G". In this case, the tacho design with increased smooth run should be used as motor feedback (type code field 6 with an "F").
- Electrical connections** The power, tachofeedback and encoder cables are directly connected to the motor with the use of connectors on the corresponding flanged sockets.
- Labelling the sides** To make sure that the sides of the MAC are clearly labelled and that there is no confusion, they have been fixed and illustrated in the figure below.

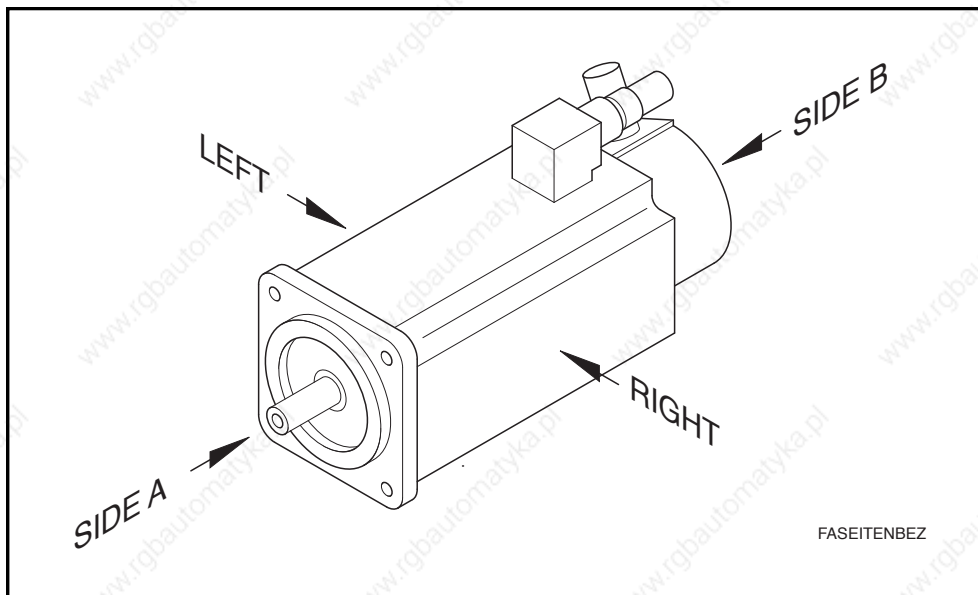

Fig 1.4: Labelling the sides of the MAC servo motor

2. Technical Data

This section outlines a description of the ambient conditions, the mechanical and electrical features of the motor as well as the motor feedback. Section 2.5 offers important details about the torque-speed characteristics which are, in turn, depicted for each motor type in sections 3.2, 4.2 through 8.2.

2.1. Ambient Conditions

Installation elevation
and ambient
temperatures

The output data outlined in the section "Technical Data" are achieved under the following conditions:

Ambient temperature: 0 ... + 45 °C

Installation elevation: 0 ... 1000 meters above sea level

If the conditions deviate from the values, then the output data will decrease as depicted in the diagrams of Figure 2.1. If higher ambient temperatures and higher installation elevations occur simultaneously, then the load factors f_T and f_H must be multiplied.

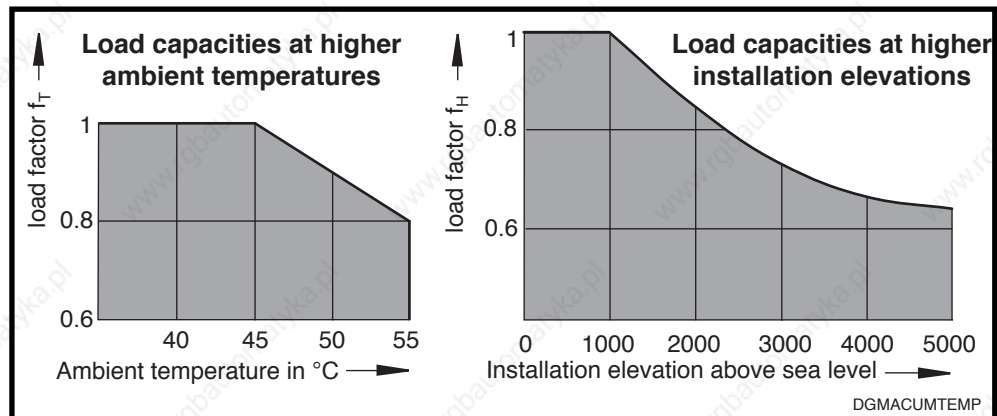

Fig 2.1: Load capacities at higher ambient temperatures and higher installation elevations

Protection category

The MAC motors are protected by their housing and covers which in construction and design adhere to the guidelines found in DIN 40 050 and are, therefore, protected against:

- contact with motor parts either moving or alive (contact guards),
- penetration by extrinsic objects and
- penetration of water.

The protection categories are laid down by the abbreviation IP (International Protection) and two numbers for the type of protection, e.g., IP 65.

The first number represents the degree of protection afforded against contact and penetration by extrinsic objects (see Figure 2.2). The second number represents the degree of protection afforded against the damaging penetration by water (see Figure 2.3).

Figure 2.4 depicts the range of the protection categories as applicable to MAC motors.

| First digit | Protection against contact and extrinsic objects |
|-------------|--|
| 0 | Little or no protection. |
| 1 | Protection against penetration by extrinsic objects with a diameter exceeding 50 mm. No protection against direct access, e.g., by a hand. Will keep larger body surfaces out, however. |
| 2 | Protection against penetration by extrinsic objects with a diameter exceeding 12 mm. Will keep fingers or similar objects out. |
| 3 | Protection against penetration by extrinsic objects with a diameter exceeding 2.5 mm. Keeps out tools, wiring or similar objects thicker than 2.5 mm. |
| 4 | Protection against penetration by extrinsic objects with a diameter exceeding 1 mm. Keeps out tools, wiring or similar objects thicker than 1 mm. |
| 5 | Protection against damaging dust. Complete penetration by dust is not prevented, but the dust may not be permitted to penetrate to the extent that the operation of the electrical equipment is in any way hindered (protected against dust). Complete protection against penetration by extrinsic objects. |
| 6 | Protection against the penetration of dust (dust-free). Complete protection against penetration by extrinsic objects. |

Fig 2.2: Protection grades - contact and penetration per DIN 40050, sec. 2 (6/72 edition)

| Second digit | Protection against Water |
|--------------|---|
| 0 | Little or not protection. |
| 1 | Protection against vertically dripping water (dripping or trickling water). It may not have any destructive affects. |
| 2 | Protection against vertically dripping water. It may not have any adverse affects on electrical equipment tilted up to 15° in contrast to its normal position (water dripping or trickling at an angle). |
| 3 | Protection against water falling at an angle of up to 60°. Does not permit any damaging affects (sprayed water). |
| 4 | Protection against water sprayed at the equipment (housing) from all directions. Does not permit any damaging affects (splashwater). |
| 5 | Protection against a jet of water sprayed from a nozzle onto the equipment (housing) from all directions. Does not permit any damaging affects (jet of water). |

Fig 2.3: Protection grades for water per DIN 40050, sec. 2 (6/72 edition)

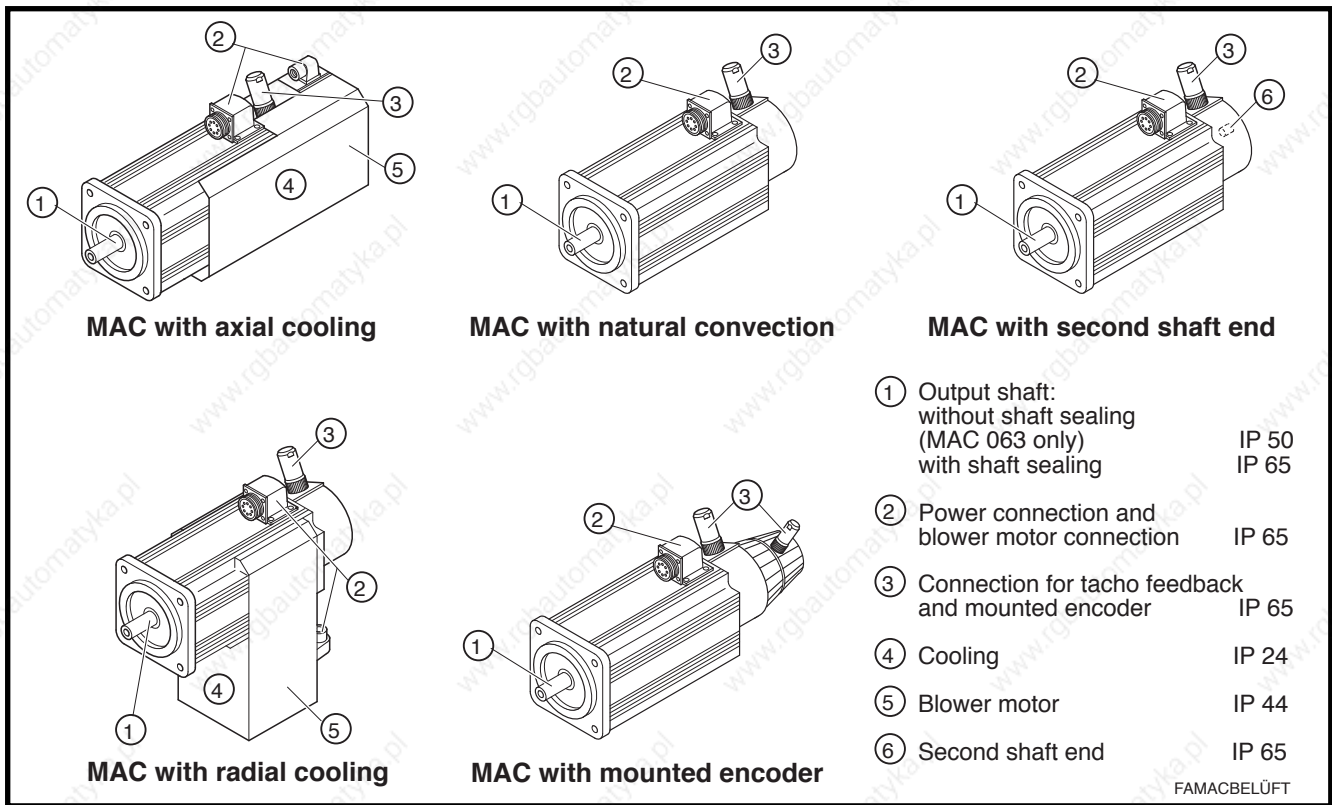

Fig 2.4: Range of protection categories of MAC motors

Ambient mechanical conditions

MAC servo motors can be operated in a stationary manner under weather-proofed conditions as per IEC 721-3-3, the 1987 edition, or EN 60721-3-3 the 6/94 edition:

- as per class 3M1 respective the longitudinal axis of the motor and
- as per class 3M6 respective the lateral axis of the motor.

The maximum values stated in Figure 2.5 thus apply to transportation and operation of MAC servo motors.

| Environmental variables | | Unit | Maximum values longitudinal axis | Maximum values lateral axis |
|-------------------------|--|------------------|---|--|
| sinusoidal oscillations | excursion amplitude | mm | 0.3 | 7.0 |
| | frequency range | Hz | 2 to 9 | 2 to 9 |
| | acceleration amplitude | m/s ² | 1 | 20 |
| | frequency range | Hz | 9 to 200 | 9 to 200 |
| shocks | total shock-response spectrum | - | Type L per IEC 721-1 edition of 1990, table 1 section 6 | Type II per IEC 721-1 edition of 1990, table 1 section 6 |
| | reference acceleration (in IEC 721-1 peak acceleration) | m/s ² | 40 | 250 |
| | duration | ms | 22 | 6 |

Fig 2.5: Maximum values of the environmental variables



MAC servo motors are only suited for such extreme demands as is the case with punching, pressing, press feeds and similar applications, if shock-damped mounted or mounted shock decoupled.

We cannot recommend a generally applicable solution for shock-damped mounting. It is dependent on the respective construction of the machine and the results of metrological tests.

A shock-damped variant for incremental encoders is available for the MAC AC servo motors. This has been tested for punching, pressing and press feed applications.

Housing coat The housing of the MAC motors is painted with a black prime coat. An additional layer of paint can cover this prime coat. The thickness of the layer may, however, not exceed 40 µm.

This prime coat is resistant to:

- weathering, yellowing and chalky build-ups as well as
- diluted acids and lyes

The coat can, however, peel if the housing is frequently cleaned with a steam cleaner.

2.2. Mechanical Features

Construction and mounting orientation The mounting flange is designed, in all types of motors, in such a way that mounting as per design B5, i.e., mounting with flange with throughholes, is possible.

Mounting mode as per design B14, i.e., mounting flange with windings, is **additionally** possible in the following motors:

- MAC 090
- MAC 093
- MAC 112
- MAC 115

Figure 2.6 demonstrates the ways that the motors can be mounted to the machine as per DIN 42950, section 1, the 8/77 edition.







| Construction | Permissible mounting orientations per DIN IEC 34-7 | | |
|--------------|---|---|---|
| B05 |  IM B5 |  IM V1 |  IM V3 |
| B14 |  IM B14 |  IM V18 |  IM V19 |

Fig 2.6: Permissible mounting orientations



In those cases where the motors are mounted in orientations IM V3 and IM V19, it is necessary to prevent liquids from collecting at the output shaft over extended periods of time. Even the use of a shaft sealing does not absolutely prevent liquids from penetrating, along the output shaft, into the housing of the motor.

Pilot diameter

To generate compatibility with the motors of other manufacturers, it is possible to also select a mounting flange with a customized pilot diameter in addition to the standard types. This is possible only with some of the motors. The choices and appropriate dimensions are listed in the table in Figure 2.8.

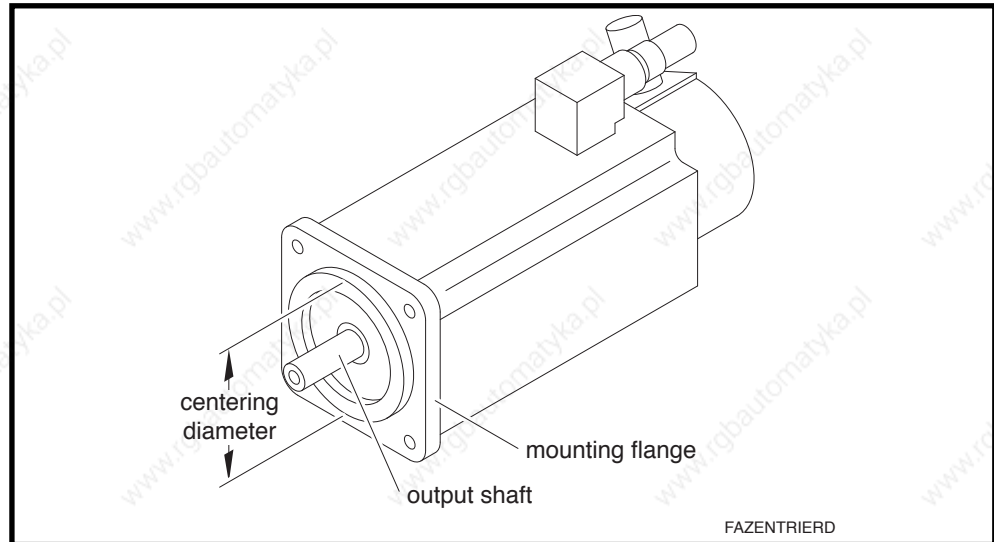

Fig 2.7: Defining the term centering / pilot diameter

| Motor Series | Pilot diameter in mm | |
|--------------|----------------------|------------------|
| | Standard types | Customized types |
| MAC 063 | 95 | — |
| MAC 071 | 95 | — |
| MAC 090 | 110 | 130 |
| MAC 093 | 110 | 130 |
| MAC 112 | 130 | 180 |
| MAC 115 | 130 | 180 |

Fig 2.8: Pilot diameters for the individual motor series

Output shaft

The design of the output shaft can be selected by the user. INDRAMAT recommends the use of plain output shafts.

Plain output shaft

A backlash-free and non-positive transmission of torque can be achieved with a plain shaft. Clamping sets, pressure sleeves or similar clamping components can be used for coupling pinions, belt pulleys or similar elements.

Output shaft with keyway

The output shaft with keyway adheres to the requirements specified in DIN 6885, sheet 1, 8/68 edition. This achieves a form-fitting torque transmission. This type of shaft-hub connection is suitable for lesser demands. A multi-

axial stress state occurs at the shaft-hub connection as a result of torsion, bending, radial and axial loads. It is possible, during powerful reverse operations, for the bottom of the key to turn out and reduce the quality of concentricity. Ever-increasing deformations can cause fractures. The use of plain shaft ends with friction-locked connections is therefore recommended.

Shaft sealing The shaft sealing is attached to the flange. It ensures that no liquids can penetrate into the motor housing along the shaft. An output shaft with shaft sealing is required for those applications where dirt or the affects of a jet of water can be present. The protection category in this case is IP 65.

In the MAC 071, 090, 093, 112 and 115, the output shafts are always equipped with a shaft sealing.

In the MAC 063 line, the output shaft can be selected with or without the sealing. The output shaft of this line is generally not equipped with the ring. The protection category in this case is IP 50.

Permissible shaft load Load is applied to the shaft as soon as radial or axial forces affect the motor shaft.

The **permissible radial force** (radial shaft load) is depicted in a diagram in sections "Shaft Load Capacity", i.e., sections 3.3., 4.3 and so on.

The permissible radial force is depicted in terms of

- the average speed
- and the point of application of force.

The **permissible axial force** (axial shaft load) can be calculated with the aid of a formula. It can be found in this section.

Thermal deformations



Thermal deformations in length affect side A of the motor. This means that the A side of the motor shaft end can shift up to 0.6 mm with respect to the motor housing. As a result, there

- **is a shifting of position by using drive pinions with helical teeth mounted to the motor output shaft but not axially fixed to the machine or**
- **thermal stress is occurring by using drive pinions with helical teeth axially fixed to the machine with bevel gear pinions. The latter can lead to damage on side B of the motor.**

Cooling For extreme loads, as is, for example, the case with continuous start-stop operations with a high level of repetitive frequency, it is possible to mount a surface-cooling unit to some of the motors.

Blower motors, operating with 1 x AC 230 V and AC 115 V, are available.

Axial surface cooling

Axial cooling is suited for those applications that need a slender form.

Axial surface-cooling units are not available for motors with a second shaft end. What is available for each line of motor is listed in the table in Figure 2.11.

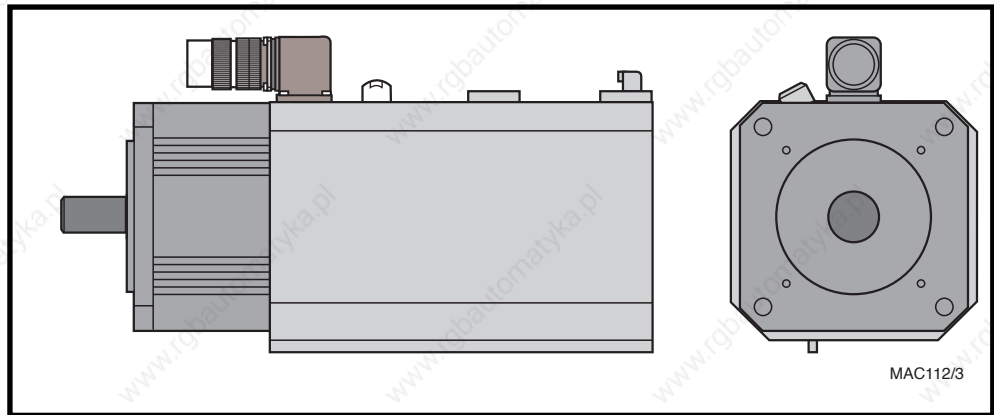

Fig 2.9: An example of a MAC servo motor with axial surface cooling

Radial surface cooling

Radial cooling is suited for those applications that need a short construction.

The use of radial surface-cooling units is recommended in those cases where shock loads are high.

If a radial surface-cooling unit is to be mounted on the motor, then the arrangement of the blower unit on the motor must be determined. The following possibilities are available with every line of motor (looking towards motor shaft):

- the blower is located under the motor shaft,
- the blower is to the left of the motor shaft or
- the blower is to the right of the motor shaft.

Radial surface cooling is not available for the MAC 063 motors with motor length A.

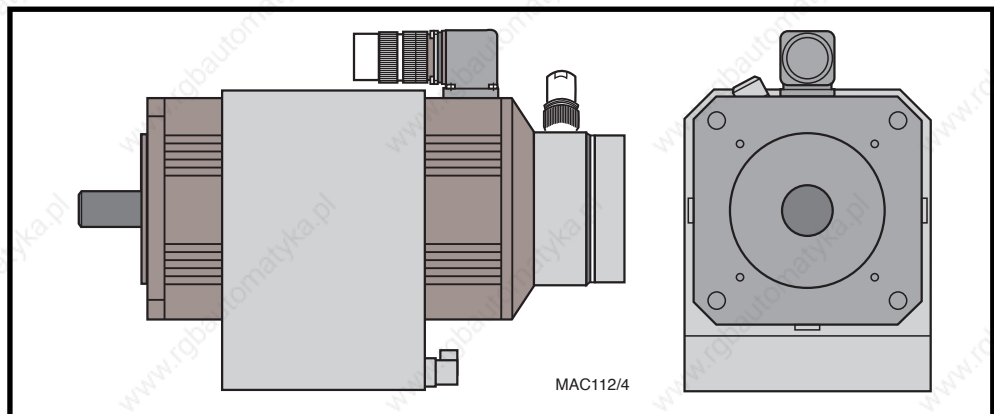

Fig 2.10: An example of a MAC servo motor with radial surface cooling with the blower under the motor shaft

The blower options for the individual motor series are listed in the table found in Figure 2.11.

| Motor type | Blower for surface cooling | |
|------------|----------------------------|--------|
| | axial | radial |
| MAC 063 | + 2) 3) | + 1) |
| MAC 071 | + 2) | + |
| MAC 090 | + 2) | + |
| MAC 093 | + 2) | + |
| MAC 112 | + 2) | + |
| MAC 115 | + 2) | + |

+ available
 1) not available for motor length A
 2) not available for motors with tachofeedback and second shaft end
 3) not available for motors with tachofeedback and mounted encoder

Fig 2.11: Blower options

Holding brake For a backlash-free holding of the servo axes when the machine is powered off, it is possible to equip them with a holding brake.

The holding brake, especially developed for those motors, works along the closed-circuit principle. At zero current, a magnetic force acts on the brake armature disc. This means that the brake is locked and holding off the axis. With the application of 24 V DC, the electrical field cancels the permanent magnetic field and the brake opens.

The customer is responsible for the control of the holding brake with the use of either a PLC or a hardware switch. Various recommendations are outlined in the Applications Manual for "MAC Servo Drives with Servo Drive Modules TDM and KDS".



The holding brake alone cannot guarantee the safety of personnel as it can fail or wear down. Additional measures must be taken to ensure personnel safety. These must be undertaken by the manufacturer of the machine and can, for example, be the mounting of a second brake.



The holding brake is not a working brake. It can wear down after 20,000 motor revolutions against the closed brake.

If the motor has been stored for any extensive period of time, then the following guidelines should be noted before commissioning it:

If the motor is stored for a period exceeding two years, then it is necessary to grind it in before using it.

To grind it in:

1. Run the motor at a speed of approximately 100 speed.
2. Close the holding brake and keep it closed for approximately 60 seconds.
Note: Open the conductor of the holding brake to the PLC or the hardware circuitry.
3. Shut down the drive after 60 seconds.
4. Reconnect the holding brake to the PLC or the hardware circuitry.

The holding brake is available with the following holding torques for each respective motor series.

| Holding torque | MAC ... | | | | | |
|----------------|---------|-----|-----|-----|-----------------|-----|
| | 063 | 071 | 090 | 093 | 112 | 115 |
| 3 Nm | X | X | | | | |
| 6.5 Nm | | X | X | X | | |
| 14 Nm | | | X | X | X | |
| 22 Nm | | | | X | | |
| 40 Nm | | | | | X ¹⁾ | |
| 45 Nm | | | | | | X |
| 60 Nm | | | | | X ¹⁾ | X |

¹⁾Not available for motor length A.

Fig 2.12: The holding torque of the holding brakes

Power connection

The user must order the output direction of the power connections in accordance with the conditions at the machine. The output direction cannot be altered after delivery.

The following variants are available (also see Figure 2.13):

- connector to side A
- connector to side B
- connector to the right
- connector to the left

Note: With the MAC 063s only the output directions towards side A or side B are available.

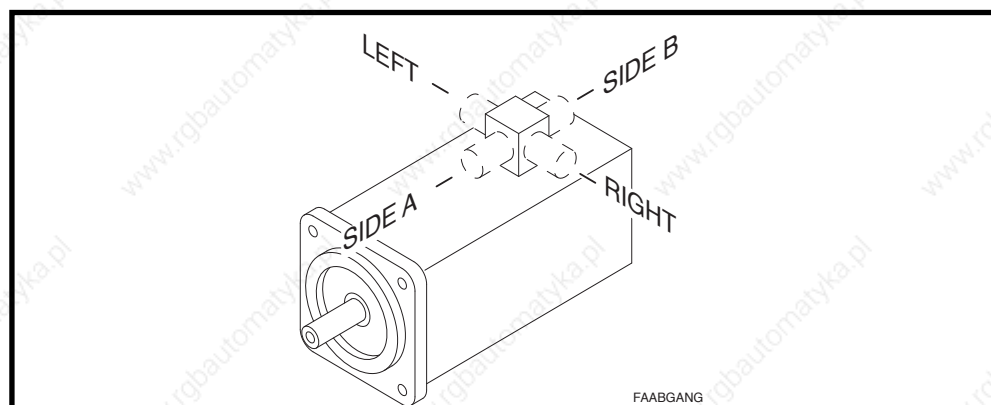

Fig 2.13: Possible output directions of the power connections

- Feedback connector Different types of connectors can be selected for connecting the motor feedback cable depending upon the installation conditions. Available are:
- straight connectors and
 - angle connectors.

Information about the allocation of connector type to motor type can be found in the dimensional data sheets and in section 13.2 "Connector for the Feedback".

Straight connector

Figure 2.14 depicts a motor with tachofeedback and straight encoder connector.

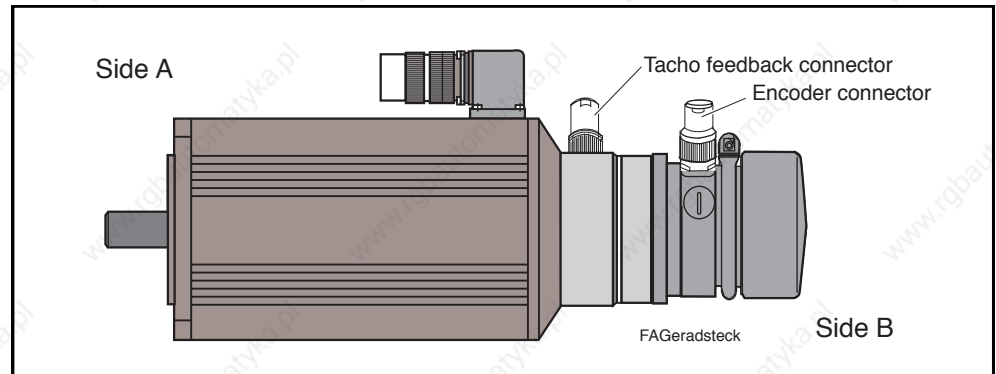

Fig 2.14: A MAC motor with straight tachofeedback and encoder connectors

Angle connector

INDRAMAT supplies and delivers the angle connectors so that the output direction of the cable, once inserted into the flanged socket, is side B of the motor.

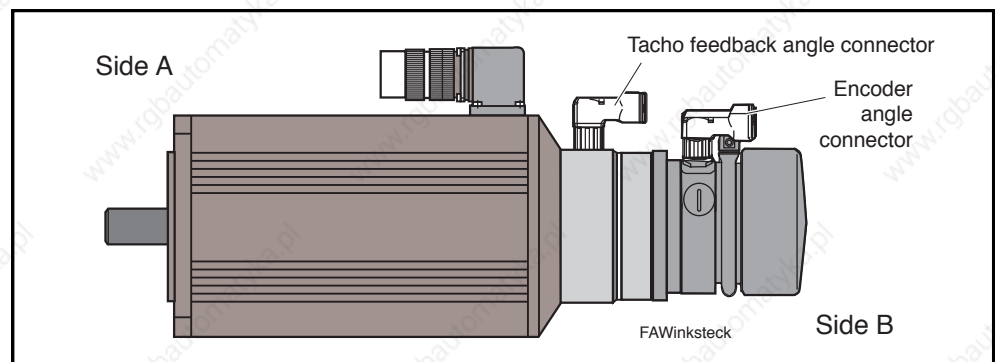

Fig 2.15: A MAC motor with angle connector (side B is output direction at delivery)

The user can change the output direction. Just release the four fixing screws (see Figure 2.16). The connector parts can now be turned in increments of 90° into the position desired.



Make sure that neither the gasket nor the cable cores of the cable are damaged when re-tightening the screws.

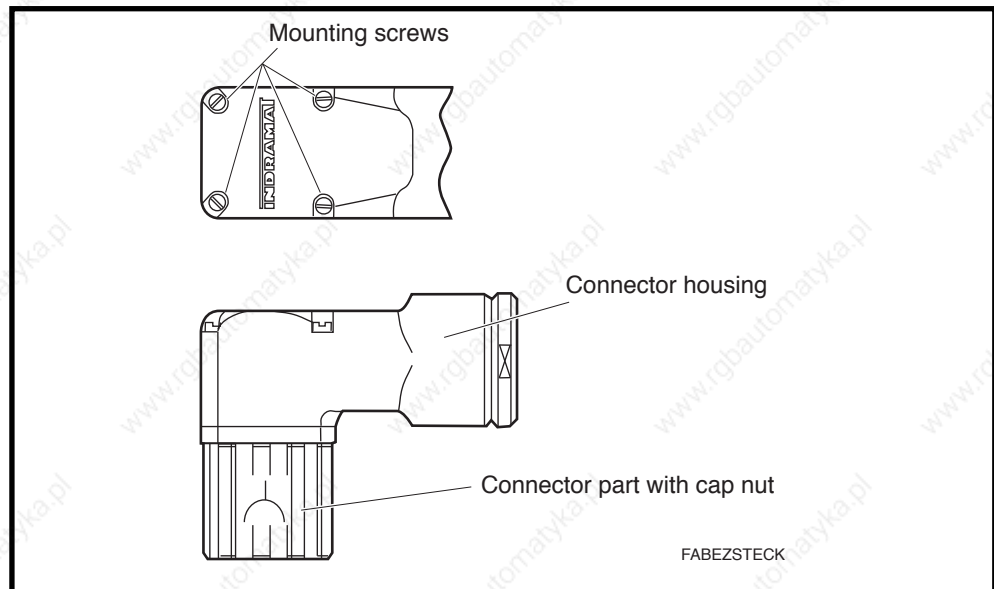

Fig 2.16: Labelling the parts of the connector



Angle connectors cannot be used in conjunction with an axial surface cooling unit.

2.3. Electrical Features

Terminal diagram

The terminal diagram shown in Figure 2.17 is purely schematic. It represents a checklist for all the necessary electrical connections to operate a MAC AC servo motor.

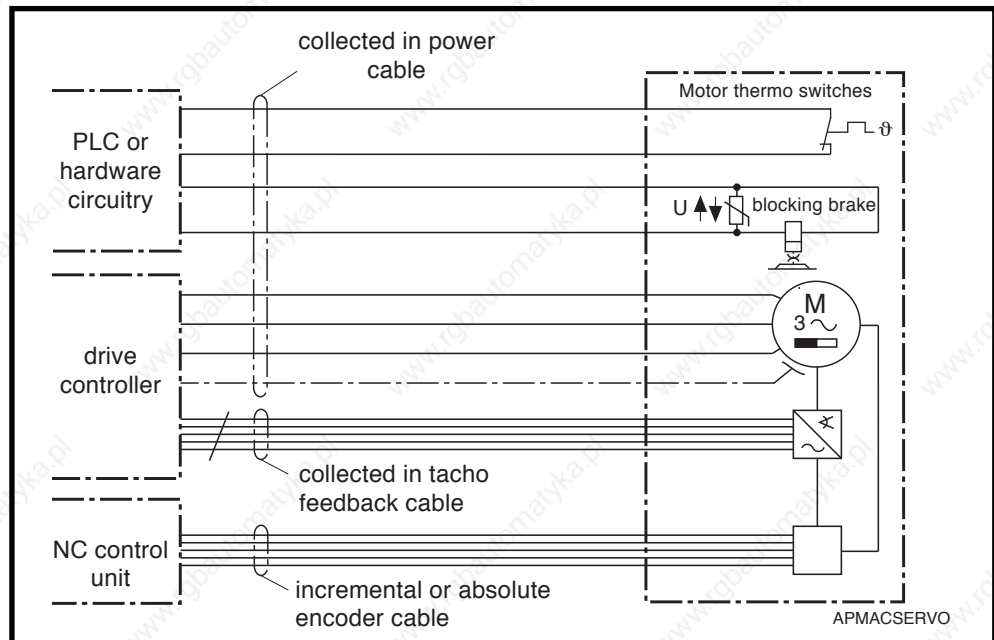

Fig 2.17: Schematic terminal diagram

The following electrical connections are on a MAC motor:

- Power connection (always present)
- Tachofeedback connection (always present)
- Incremental or absolute encoder connection (this depends on the type of motor implemented)

If a blower for surface cooling is mounted to the motor, then a motor blower connection is also there. This is not shown in the terminal diagram.

The electrical connections of INDRAMAT drives have been standardized to minimize cable diversity. Sections 12 and 13 specify the electrical connections for a given application and motor type.

Power connection The following connections are integrated into the power connection:

- power cable,
- connecting cable for the thermo switch(es)
- and the connecting cable for the holding brake.

There are thermo switches built into the windings of the motor and the stator housing. They are electrically connected in series and conducted together at the power connection out of the motor housing. The opening of the thermo switch must be detected either by a superordinate PLC or hardware circuitry, and then an appropriate error reaction generated as quickly as possible.

Motor power connectors for the electrical power connections are available for either:

- crimping or
- soldering.

Power cables with metrical diameters can be either crimped or soldered to the motor power connector. Power cables with inch diameters can only be soldered.

Feedback connection There is a 12-pin flanged socket on the motor for the feedback and encoder connections.

The connection diagram, available feedback cables and connectors are all outlined in section 10.

Motor blower connection The motor blower is integrated into the hardware circuitry as per customer requirements as, for example, via a protective motor switch which would then operate independently of the controller.

The connector cable must have three cores with a diameter of at least 0.75 mm².

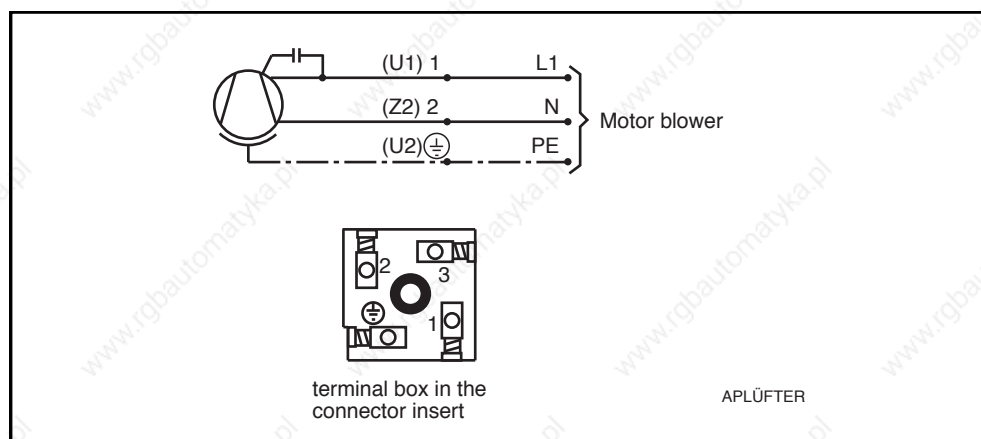

Fig 2.18: How to connect the blower

Connecting the cable to the motor blower

The following steps describe how to connect the cable to the motor blower. The individual parts of the connector are illustrated in Figure 2.19.

Procedure:



The cable may only be connected by either an electrician or trained personnel under the supervision of an electrician.

1. Release conduit thread screw (6) (SW 17).
2. Remove slotted screw (1) with screw driver (5) from flanged socket (4).
3. Remove connector housing (2) with connector insert (3) from flanged socket (4).
4. Pull out slotted screw (1).
5. Pull connector insert (3) out of connector housing (2) with screw driver (5) (see Figure 2.19).
6. Slide conduit thread screwed joint (6), ring (7), gasket (8) and connector housing (2) onto the cable (3x0.75 mm²).
7. Strip cable sheath at a length of approx. 20 mm, strip litz wire for approx. 10 mm. Now connect as per terminal diagram in Figure 2.18 to the terminal box in the connector insert (3).
8. Push connector insert (3) into connector housing (2), attach slotted screw (1) and screw connector onto flanged socket (4).
9. Remount conduit thread screwed joint (6) making sure strain relief is adequate!

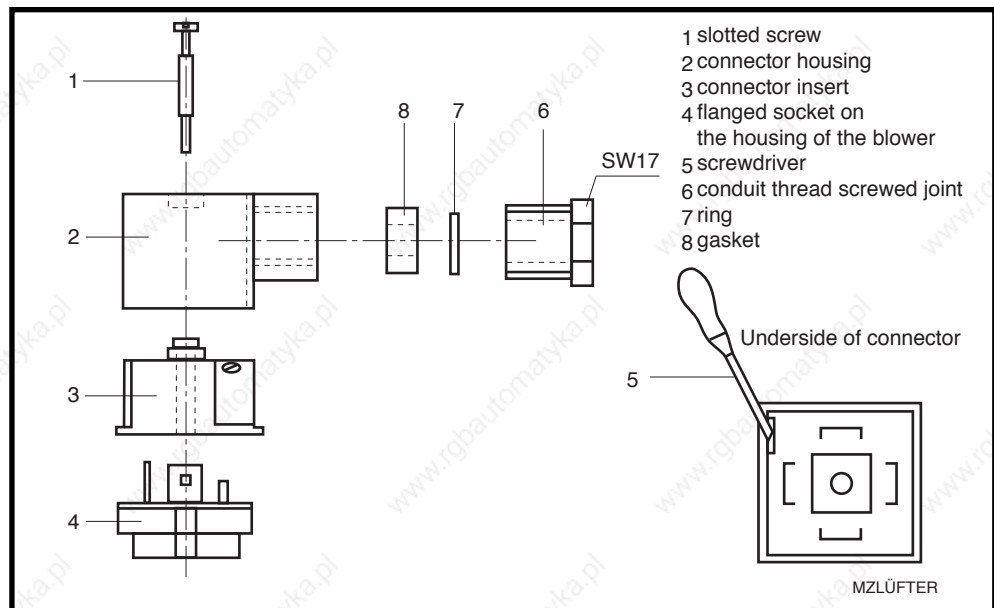

Fig 2.19: The parts of a blower connector

2.4. Motor Feedback

The motors are equipped with a motor feedback for the evaluation of position and speed and for the detection of rotor position. The motors are available in those versions illustrated in Figure 2.20.

Versions The motor feedback is always made up of a tachofeedback and can be additionally fitted with an encoder.

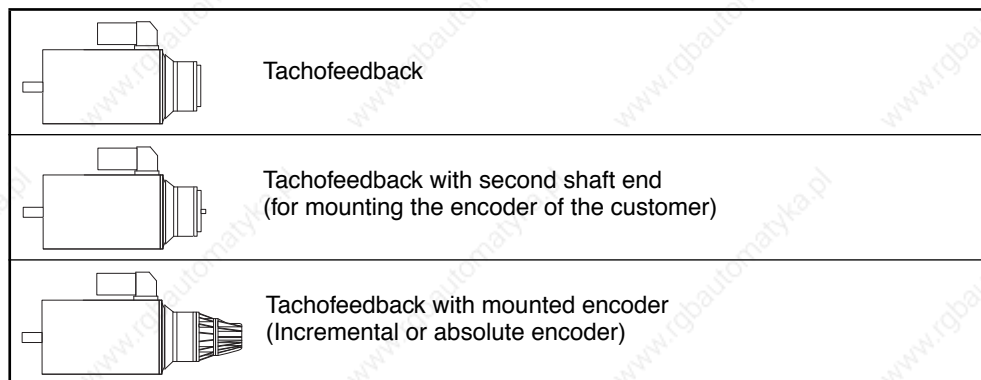

Fig 2.20: Available motor feedback versions

2.4.1. Tachofeedback

This design makes it possible to detect and evaluate both rotor position and velocity. The velocity feedback value is generated with residual ripple in some models and is suited for:

- either standard applications (tacho type „C“; see type code)
- applications with extreme high smooth run qualities (tacho type „F“; see type code)

The "Tachofeedback" version can be used in all machines in which there is, for example, a direct position evaluation via a linear scale or with applications with uniform rotations.

Tacho voltage can be selected to meet the following:

- to match nominal motor speed
With a nominal speed of $> 3000 \text{ min}^{-1}$ tacho voltage equals $1.5\text{V}/1000 \text{ min}^{-1}$.
With a nominal motor speed of $\leq 3000 \text{ min}^{-1}$ tacho voltage equals $3\text{V}/1000 \text{ min}^{-1}$.
- $1.5 \text{ V}/1000 \text{ min}^{-1}$ for speeds exceeding 3200 min^{-1} in motors with a maximum nominal speed of 3000 min^{-1}
- $6 \text{ V}/1000 \text{ min}^{-1}$ for applications making higher demands of the resistance to interference in tachofeedback lines or requiring smooth run qualities at a maximum nominal speed of 1600 min^{-1} .

The options for each line of motor have been compiled in Table 2.21.

| Motor Series | Tacho version | Tacho Voltage | | |
|--------------|---------------------------|-----------------------------|---|---|
| | | matches nominal motor speed | $\frac{1.5 \text{ V}}{1000 \text{ min}^{-1}}$ | $\frac{6 \text{ V}}{1000 \text{ min}^{-1}}$ |
| 063 | standard | X | | |
| | higher smooth run quality | X | | |
| 071 | standard | X | X | |
| | higher smooth run quality | X | X | |
| 090 | standard | X | X | |
| | higher smooth run quality | X | X | X |
| 093 | standard | X | X | |
| | higher smooth run quality | X | X | |
| 112 | standard | X | X | |
| | higher smooth run quality | X | X | X |
| 115 | standard | X | X | |
| | higher smooth run quality | X | X | |

Fig 2.21: Optional tachofeedbacks and allocation to motor series

2.4.2. Tachofeedback and Second Shaft End

This version is identical to the version "Tachofeedback", expanded, however, with an accessible second shaft end on side B of the motor. Additional components, encoders in particular, can be mounted hereto.

The second shaft end has a protection category of IP 65, i.e., the component mounted does not need to be completely sealed.

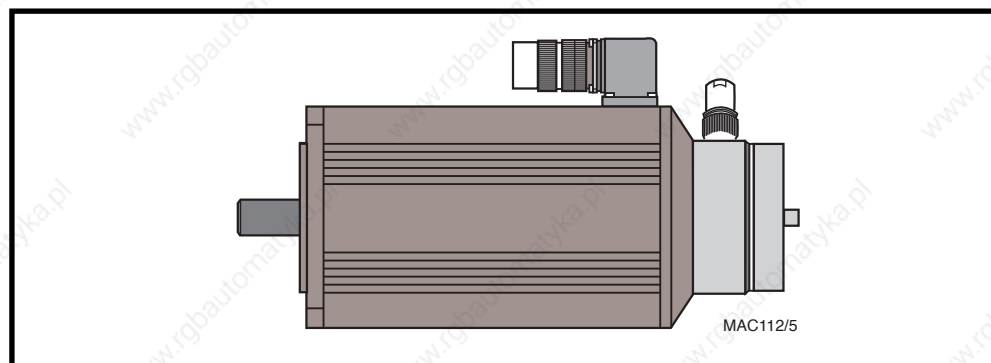

Fig 2.22: MAC servo motor with tachofeedback and a second shaft end

2.4.3. Tachofeedback with Mounted Encoder

This version corresponds to the "Tachofeedback" version with respect to the detection of velocity feedback value and rotor position. Mounted encoders in the following versions are available for position detection and evaluation:

- Standardly mounted incremental encoder for use with machines with lower shock loads.
- Incremental encoders with shock-damped mounting for use in presses, stamping machines and similar machinery
- and an absolute encoder

These mounted encoders have been especially designed for INDRAMAT motors and are extremely resistant to environmental conditions.

These are introduced in greater detail in sections 2.4.4. and 2.4.5.

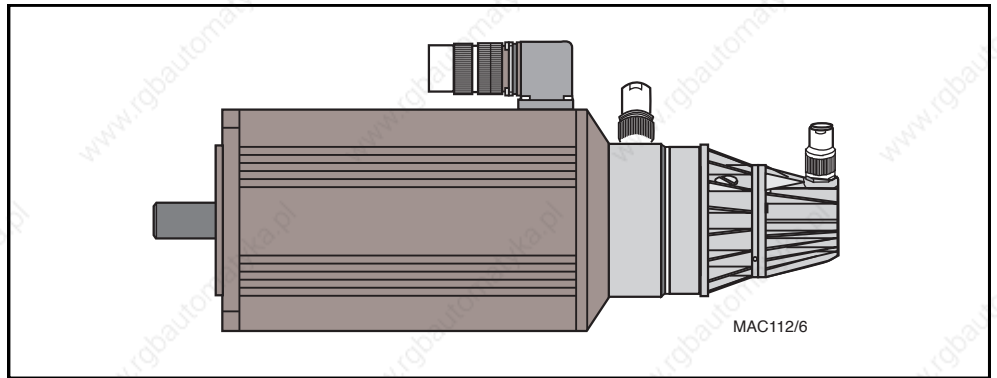

Fig 2.23: MAC servo motor tachofeedback with mounted encoder (ex: incremental encoder)

2.4.4. Incremental Encoders

Incremental encoders work with either square-wave pulses or sinusoidal signals. They are available to accommodate different supply voltages. The available versions are listed in Figure 2.24.

| No. of pulses/ no. of lines | Pulse | | |
|--------------------------------|--------------------|----------|-------------------|
| | Square-wave signal | | Sinusoidal signal |
| | Supply voltage | | Supply voltage |
| | 5V | 10 - 16V | 5V |
| 50 | 568LV | | |
| 125 | 542LV | | |
| 200 | 553LV | | |
| 250 | 515LV | | 527BX |
| 400 | 516LV | 634LX | |
| 500 | 517LV | | |
| 600 | 572LV | | |
| 625 | 524LV | | |
| 900 | | | 593BX |
| 1.000 | 518LV | | 647BX |
| 1.024 | 519LV | | |
| 1.250 | 520LV | 637LX | |
| 1.500 | 538LV | | |
| 1.800 | 574LV | | |
| 2.000 | 521LV | | |
| 2.500 | 522LV | | |
| 3.600 | 594LV | | |
| 5.000 | 511LV | | |

Incremental encoders can only be mounted to MAC 063s with natural convection or radial surface-cooling units.

Fig 2.24: Incremental encoder options

| | |
|------------------------------------|--|
| Voltage source: | 5 V, ± 5 % |
| Current consumption: | 150 mA |
| Signal level: | U(high) ≥ 2.5 V; U(low) ≤ 0.5 V; at 20 mA |
| Load capacity: | 20 mA at "high" and "low" signal |
| Total operating time: | rise and fall times ≤ 200 ns |
| Maximum sampling frequency: | 300 kHz |
| Incremental encoder signal: | TTL - square wave pulse sequence and its inverted signals with a rotational field towards the right when looking towards the motor shaft |

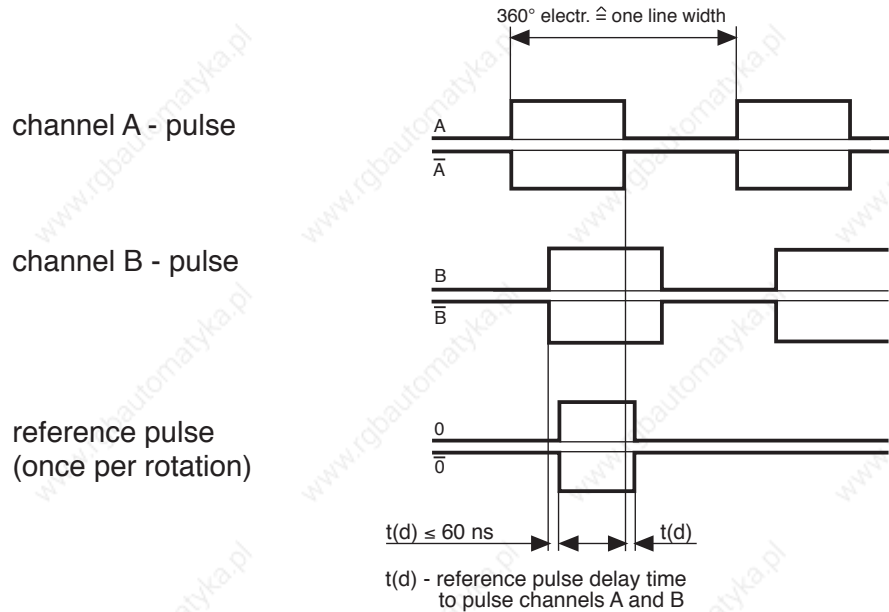

Recommended switching of the secondary electronics:

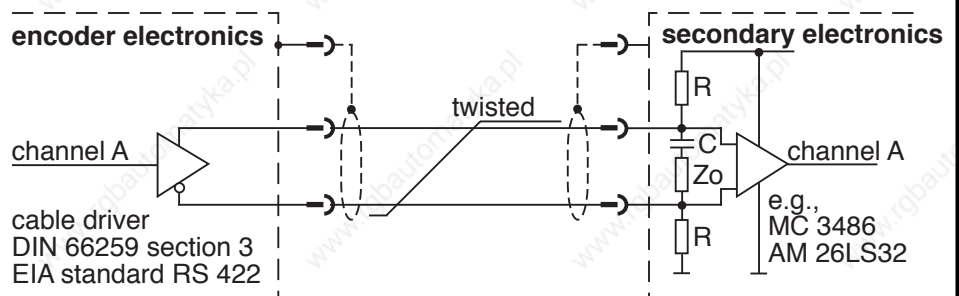

R = 4,7 k Ω ; prevents switching in the event of a break in the line
 C = 1 nF .. 10 nF; decreases the current consumption of the encoder
 Zo = 120 Ω ... 140 Ω ; as per characteristic wave impedance of cable

TDANBAUINKR5V

Fig 2.25: Incremental encoder, technical data, 5V voltage supplied, square-wave pulse

| | |
|------------------------------------|--|
| Voltage source: | 10-16 V |
| Current consumption: | 220 mA |
| Signal level: | $U(\text{high}) \geq 7 \text{ V}$; $U(\text{low}) \leq 2 \text{ V}$ |
| Load capacity: | 60 mA with "high" and "low" signal |
| Total operating time: | rise and fall time $\leq 200 \text{ ns}$ |
| Maximum sampling frequency: | 75 kHz |
| Incremental encoder signal: | TTL - square wave pulse sequence and its inverted signals with a rotational field towards the right when looking towards the motor shaft |

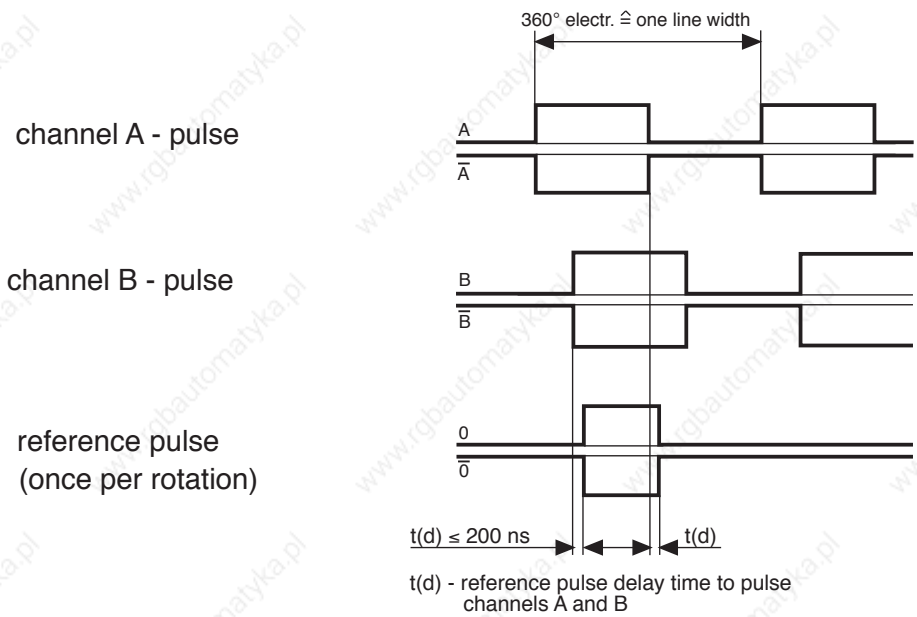

Recommended switching of the secondary electronics:

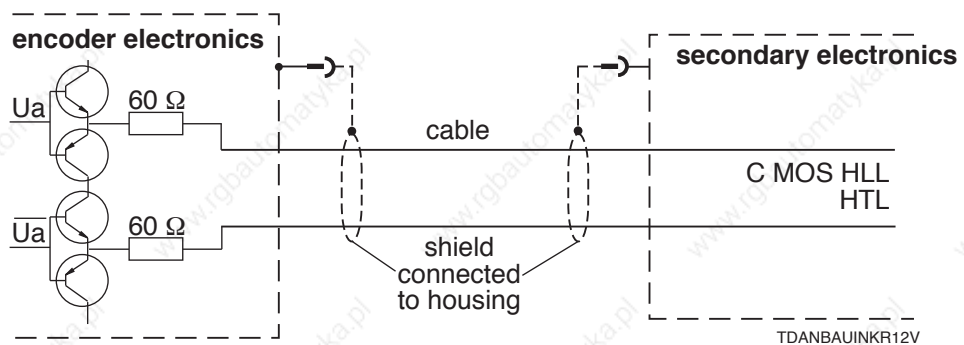

Fig 2.26: Incremental encoder, technical data, 12V voltage supplied, square-wave pulse

Voltage source: 5 V ± 5 %
Current consumption: 120 mA
Signal: two current signals I_{e1} and I_{e2} approaching sinusoidal shape
Signal size with load of 1 kΩ: I_{e1} approx. 11 μA ss
 I_{e2} approx. 11 μA ss
Reference signal: 1 signal I_{e0} per revolution
maximum scanning frequency: depends on slave electronics

Incremental encoder signals:

output signals

I_{e1}

I_{e2}

reference pulse

I_{e0}

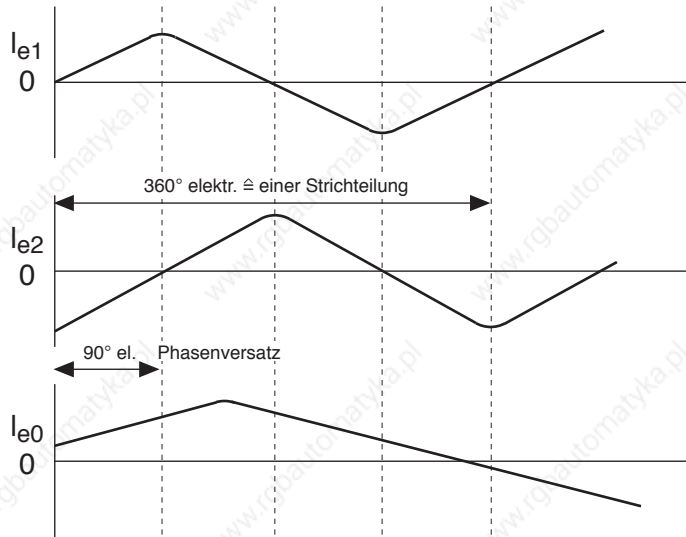

Speed:

$$0 \text{ to } \frac{f_{\max} \text{ (kHz)}}{Z} \cdot 10^3 \cdot 60 \text{ min}^{-1}$$

Z = number of lines

f_{\max} = maximum input frequency of slave electronics

TDInkrSINUS

Fig 2.27: Incremental encoder, technical data, 5V voltage supplied, sinusoidal signals

Setting the reference point

If INDRAMAT MAC servo motors are supplied with mounted incremental encoders and **motor output shafts with keyway**, then the reference point of the encoder is set to a defined angular position. This defined angular position of the reference point to the keyway of the motor output shaft makes it possible, if procedures are followed, to replace drives without adjustment work thus eliminating the risk of unnoticed dimensional displacements.

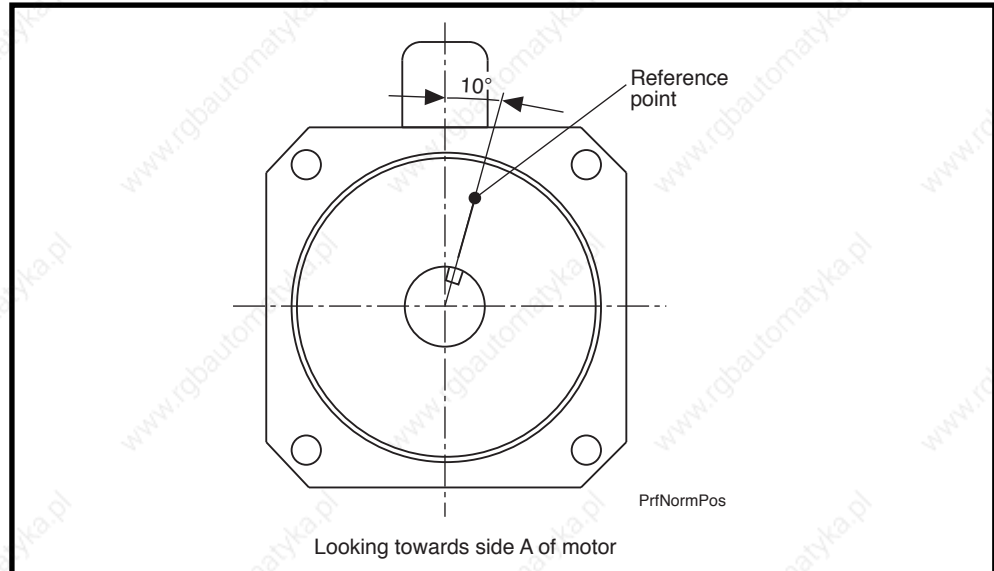

Fig 2.28: Standard position of the output shaft with keyway with encoder reference position in a MAC motor

The reference point can be mechanically changed if incremental encoders are used in MAC AC servo motors.

This is possible with:

- motors without surface cooling (natural convection)
- motors with radial surface cooling

This is not possible with:

- motors with axial surface cooling. The construction of the blower shroud determines the location of the incremental encoder connector with respect to the motor. This allocation changes, however, with the setting of the reference point!



When replacing the drives, changing the reference point setting results in considerable dimensional shifting. It must be checked by someone capable and authorized to do so and the reference point must, then, be reset. To replace a drive without causing this problem, we recommend that the defined reference point not be reset. INDRAMAT instead recommends an adaption of the reference dimension via the control unit.

Changing the
reference point setting



Procedure:

Only an electrician or properly trained personnel under the supervision of an electrician may set the reference point.

1. Switch the power section of the drives off.
2. Lock the motor shaft.

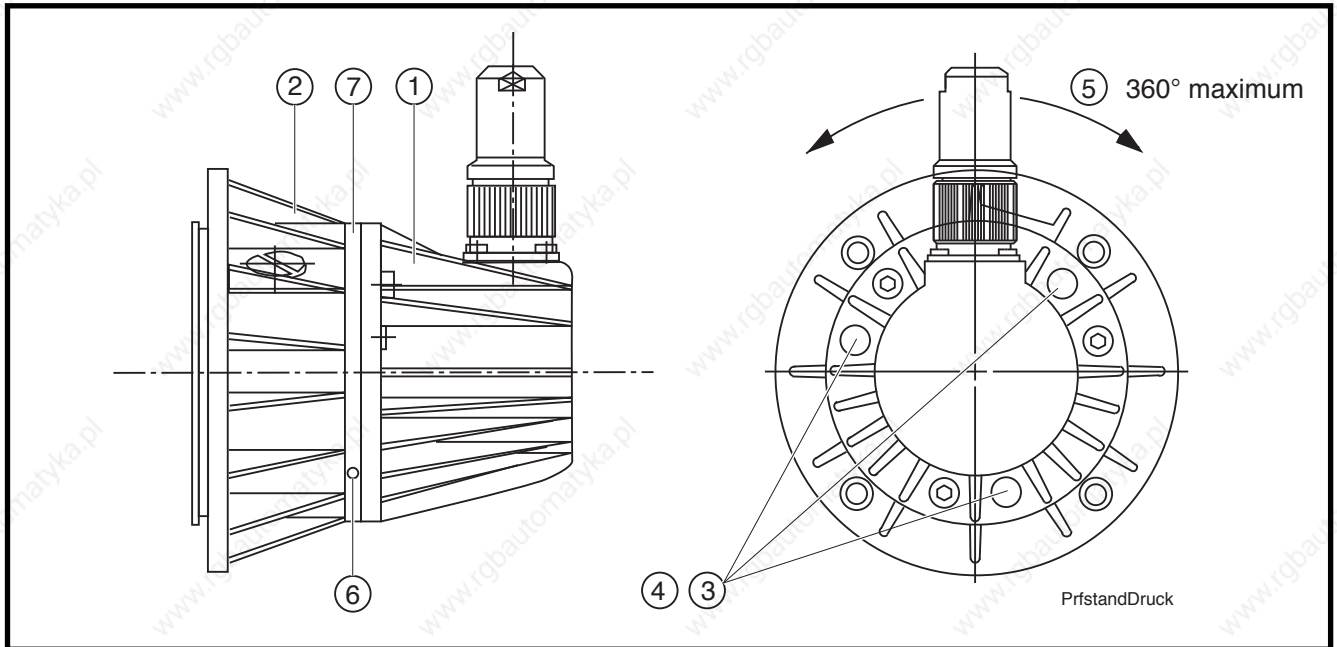

Fig 2.29: Standard die cast housing with mounting flange

3. Remove screw covers (3).
4. Release the allen screws (4) with one-half a turn.
5. Set the desired reference point by turning the encoder housing (1) with respect to the mounting flange (2). The radial drill hole (6), diameter 4 mm, in the plastic flange (7), can be used to assist this procedure. The encoder housing can be turned 360° in both directions. This changes the position of the encoder connector to the motor (interference contour).
6. Tighten allen screw (4) with 3,6 Nm.
7. Press screw covers (3) back into place.
8. Release motor shaft lock.
9. Switch power section of the drive back on.

2.4.5. Absolute Encoder

The absolute encoder supplies an unequivocal (absolute) position value for every position with a change in position.

These values remain available even after there has been an emergency off or a power failure. This eliminates the need for extensive referencing procedures of the individual axes.

The feedback position value remains available after the machine is switched back on even in the event that the axis of the machine were moved when in a currentless state.

In addition to the absolute position represented in terms of 360° , the absolute encoder also represents a defined number of resolutions in terms of absolute units. This resolution equals 24 bit, gray code, 4096 increments / $360^\circ \cdot 4096$ resolutions.

Figure 2.30 lists the designations of the absolute encoder.

| Designation | No. of pulses | Supply source in V | MAC... | | | | | |
|-------------|---------------|--------------------|--------|-----|-----|-----|-----|-----|
| | | | 063 | 071 | 090 | 093 | 112 | 115 |
| 144SG | 4096 • 4096 | 10-32 | X | | | | | |
| 154SG | 4096 • 4096 | 10-32 | | X | | | | |
| 164SG | 4096 • 4096 | 10-32 | | | X | X | X | X |

Fig 2.30: Designations of the absolute encoder

| | |
|---|---|
| Voltage source: | 5 V - 32 V DC, protected against polarity reversal |
| Current consumption: | ≤ 3 W |
| Scan code: | Gray Code |
| Clockwise counting direction looking onto shaft: | rising |
| Data transmission: | synchronous, serial |
| Serial data output: | driver per EIA RS 422, secured against short-circuits |
| Monoflop time t_m: | 15 μ s < t_m < 25 μ s |
| Clock frequency: | 200 kHz |
| Minimum phase break: | 30 μ s |
| Data format: | 24 Bit |
| Protection category in mounted state: | IP 65 |

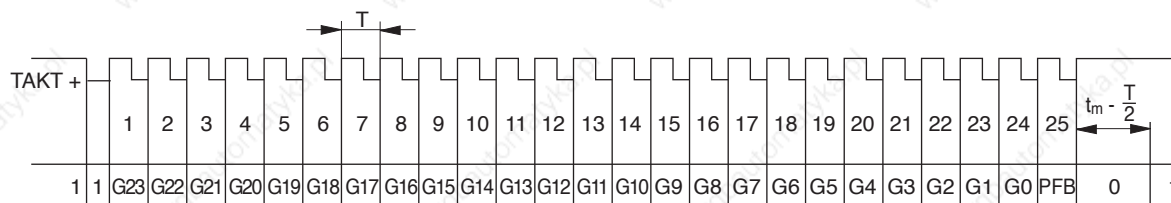

PFB = power failure bit
 T = pulse signal duration
 t_m = monoflop time

Power failure bit

If the power supply (> 5 V) is interrupted for periods exceeding 100 μ s then the encoder information can be false.

The power failure bit (PFB) identifies this error. In the event of a voltage interrupt, the PFB in the serial information is set to logical 1 via a comparator.

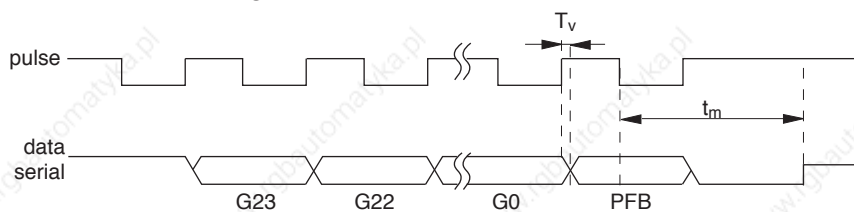

Delay time T_v : max 300 ns (clock (+) to data (+) or data (-))

Clock input circuitry

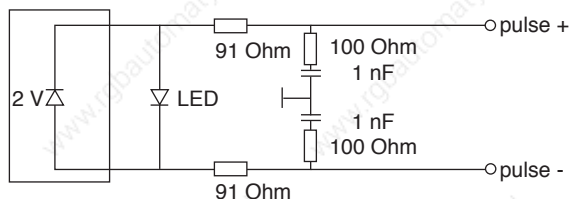

Data output circuitry

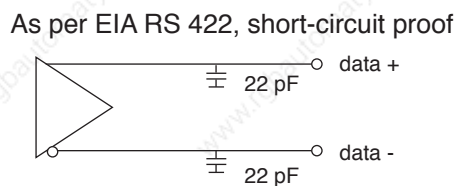

TDABSOLUT

Fig 2.31: Absolute encoder - technical data

Replacing the encoder

The absolute encoders which INDRAMAT mounts represent measuring systems of the highest quality developed for use on production machinery.

If an encoder should, however, at some point need to be replaced, then an entire replacement unit can be installed on site.



Do not use harsh cleansing agents to clean components.

The encoder may only be operated with a screwed on filler cap (10) (see Figure 2.32) as dirt contamination can cause it to fail.

The tools needed to work on the absolute encoder are:

- Allan key, 90° offset, SW3
- Allan key, straight, SW4
- torque key 0 to 5 Nm
- adjusting tool, part no.: 243 044



The absolute encoder may only be mounted or removed by an electrician or by trained personnel under the supervision of an electrician.

Removing the absolute encoder

Procedure:

1. Switch power section of drive off.
2. Switch control voltage off.
3. Pull out encoder.

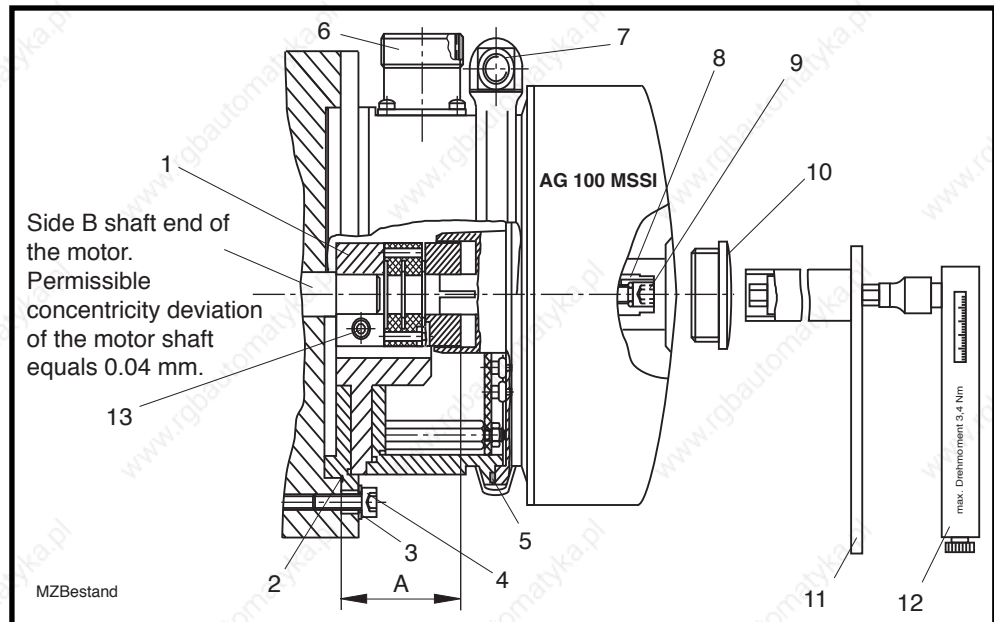

Fig 2.32: Components of an absolute encoder with tools and torque key

4. Remove filler cap (10) (Fig 2.32) out of encoder housing.
5. Place adjusting tool (11) onto the hexagon of the expander (8) and hold in this position.
6. Pull out the expander (9) with the key (SW4) using approximately six turns. **Do not use** the adjusting tool for this task!
7. Release screws (4) with the key (SW4) and pull the mounted encoder unit carefully out.
8. Check the coupling unit for wear and tear.

- If necessary, pull slotted screw out (13) with key (SW3) and pull out the clamped coupling unit of the motor shaft.

Preparing to mount the absolute encoder

Procedure:

- Remove the new unit to be mounted from its packaging.
- Remove the filler cap (10) from the encoder housing.
- Make sure there is no tension in the expander (8).
- Check whether the enclosed coupling unit can easily be slid onto the expander (8). If not, put adjusting tool onto hexagon of the expander (8) and hold. Then, using an Allan key (SW4) turn the expander (9) six turns to the left. There should now be no tension in the expander. This is the prerequisite for correctly mounting the encoder unit.

Mounting the absolute encoder

Procedure:

- Switch power section of drive off.
- Switch control voltage off.
- Remove servo motor cover (see Figure 2.33).
- Remove all grease from side B of the motor.

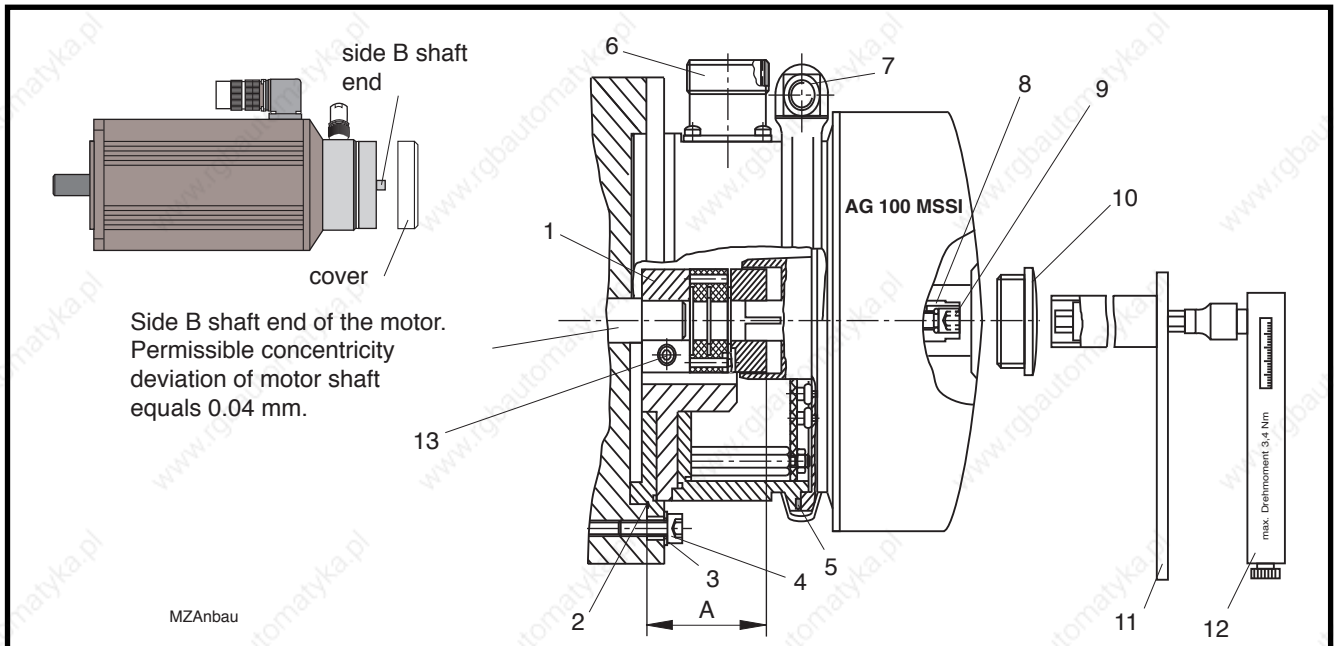

Fig 2.33: Mounting the absolute encoder

- Push the coupling unit (1) onto side B of the shaft end.
- Set dimension A (distance flange mounting surface to the end of the coupling unit). Dimension A: MAC 063: 39.7 ± 0.5 mm
Dimension A: MAC 071 - 115: min. 35.5 mm/max. 37 mm
- Tighten screw (13) with key (SW3) 3.4 Nm.
- Check whether O-ring (2) is properly mounted.
- Place unit carefully onto motor without tipping. Feed expander (8) into coupling unit at the same time.
- Turn connector (6) so that the angle is set for the respective motor (see dimensional data, sections 3 to 8).
- Mount unit with screws (4) and washers (3) to the motor.
Tightening torque: 2.8 Nm for MAC 063
5.7 Nm for MAC 071 - 115
- Place adjusting tool (11) onto expander (8) and hold in this position.

13. Tighten expander (9) with torque key (12). Torque: 3.4 Nm.
14. Screw filler cap (10) into encoder housing.
15. Put absolute encoder connector into place.
16. Apply power.
17. Switch drive on and check whether encoder is functional.
18. Run a homing procedure.

Setting the reference point of the absolute encoder

If INDRAMAT MAC servo motors are delivered with absolute encoders mounted, then it is possible to set the reference point in several different ways.

Procedure 1

Set zero point of absolute encoder to the mechanical reference point.

1. Set servo drive to the reference point (in jog mode).
2. Connect absolute encoder to the control unit.
3. Release the connection absolute encoder to motor shaft (adjusting tool, part no.: 243 044).
4. Turn absolute encoder to zero point; evaluate at control unit.
5. Conduct a test run.

Procedure 2

Set the end of the measuring range of the absolute encoder to the mechanical end of the axis.

1. Run the mechanical system into the end position.
2. Connect the absolute encoder to the control unit.
3. Release the connection absolute encoder to motor shaft (adjusting tool, part no.: 243 044).
4. Turn the absolute encoder to relevant end position.
5. Re-establish absolute encoder - motor shaft connection.
6. Conduct a test run.

Procedure 3

Conduct an electronic zero point displacement in the control unit (depends on the control unit used)

1. Absolute encoder remains clamped to the servo drive.
2. The drive is firmly connected to the mechanical system.
3. Run the servo drive to the reference point (in jog mode).
4. The absolute value of the encoder is read in and interpreted as the zero point by the control unit.

2.5. Torque-Speed Characteristics

This section contains explanations about the torque-speed characteristics. These are depicted for each type of motor in sections 3.2, 4.2 through 8.2.

The curves of some of the motors may deviate from the features described here. These deviations are, however, then relevantly documented

What is depicted The operating curves depict:

- the torque limiting data,
- the speed limiting data and
- the operating curves.

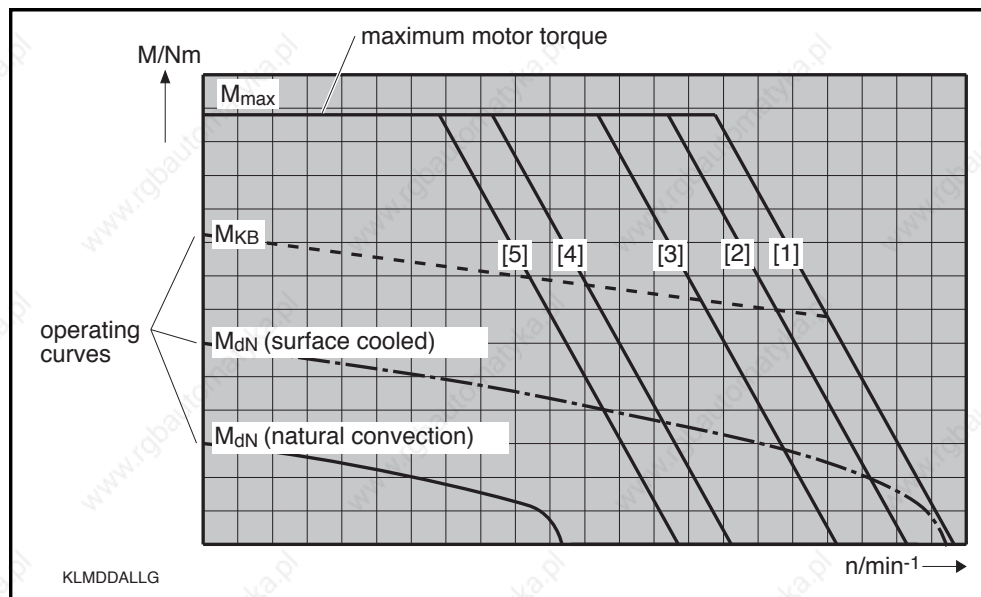

Fig 2.34: The torque-speed characteristics illustrated

Usage The torque-speed characteristics can be used:

- to record information from the selection documentation,
- to determine the possible maximum usable speed for a special application with known torque requirements and
- to check whether the application remains within the thermal limits of the motor. The effective torque for a critical cycle must be below the S1 continuous operating characteristics curve of the arithmetically averaged speed.

Limiting value for torque

The horizontal line M_{max} depicts the theoretically possible maximum torque of the motor. The drive can limit this maximum torque resulting from the various motor-controller combinations. It is outlined in the selection documentation.

Limiting value for speed

Maximum motor speed is determined by the DC bus voltage produced by the supply source at the drive. Depending upon the DC bus voltage at the drive, maximum torque drops at a breaking point

DC bus with a regulated power supply

In the case of those supply modules with a regulated power supply, the power data of the drive-motor combination are not dependent on the fluctuations of the mains voltage.

DC bus voltage with an unregulated power supply

In the case of those supply modules with an unregulated power supply, the power data of the drive-motor combination are dependent on the fluctuations of the mains voltage. Varying power data are achieved under the following conditions at the mains:

- 10 % overvoltage
- nominal voltage
- 10 % undervoltage

The declining lines are numbered. The following allocations apply:

- [1] -DC bus voltage with a regulated power supply (e.g., KDV 4, TVD, KVR, TVR) or an unregulated power supply if AC mains input voltage is 10% higher than the rated 3 x 230 volts AC (e.g., TVM 2, KDV 1, KDV 2, KDV 3, DSC 3)
- [2] -DC bus voltage with an unregulated power supply connected to a three-phase mains rated at 3 x AC 230 V (e.g., TVM 2, KDV 1, KDV 2, KDV 3, DSC 3)
- [3] -DC bus voltage with an unregulated power supply connected to three-phase mains rated at 3 x AC 230 V with 10% undervoltage (e.g., TVM 2, KDV 1, KDV 2, KDV 3, DSC 3)

Furthermore, the speed could be limited by the tacho voltage of the tacho generator.

Allocate the curves determined by the tacho voltage of the tacho generator as follows:

- [4] -tacho generator with 3 V/1000 min⁻¹ tacho voltage
- [5] -tacho generator with 6 V/1000 min⁻¹ tacho voltage
- [6] -tacho generator with 1.5 V/1000 min⁻¹ tacho voltage

Operating curves

The operating curves depict the permissible continuous torque M_{dN} (operating mode S1) and the intermittent operating torque M_{KB} (operating mode S6 per DIN VDE 0530; 7/91 edition).

The following allocations apply:

- S1-continuous curve of the motor with natural convection
- - - - - S1-continuous curve of a motor with surface cooling
- - - - - S6-intermittent operating curve:
at an ON time of 25 % of the motor with natural convection or with the ON time indicated in the curve with surface cooling. Maximum duty cycle time is indicated in Figure 2.35.

| Motor series MAC ... | Maximum duty cycle time |
|-------------------------|-------------------------|
| 063 | 10 min. |
| 071, 090, 093, 112, 115 | 15 min. |

Fig 2.35: Maximum duty cycle time with intermittent operations

Empty page

3. MAC 063

3.1. Technical Data

| Designation | Symbol | Unit | Motor type MAC ... | | | |
|---|-------------------|-------------------|-------------------------|-------------------------|-------------------------|--------------------------|
| | | | 063 A - - - ES | 063 B - - - GS | 063 C - - - MS | 063 D - - - JS |
| Nominal motor speed ¹⁾ | n | min ⁻¹ | 3500 | 3500 | 3500 | 3500 |
| Continuous torque at standstill ²⁾ | M _{dN} | Nm | 0.8 (1.0) ⁵⁾ | 1.5 (1.7) ⁵⁾ | 2.1(2.7) ⁵⁾ | 2.7 (3.5) ⁵⁾ |
| Continuous current at standstill | I _{dN} | A | 2.2 (2.7) ⁵⁾ | 3.6 (4.0) ⁵⁾ | 4.1(5.3) ⁵⁾ | 5.1 (6.6) ⁵⁾ |
| Rotor moment of inertia ³⁾ | J _M | kgm ² | 2.4 x 10 ⁻⁴ | 3.2 x 10 ⁻⁴ | 4.0 x 10 ⁻⁴ | 4.8 x 10 ⁻⁴ |
| Torque constant at 20 °C | K _m | Nm/A | 0.370 | 0.42 | 0.51 | 0.53 |
| Windings resistance at 20 °C | R _A | Ohm | 9.6 | 4.1 | 2.8 | 1.9 |
| Windings inductance | L _A | mH | 9.1 | 3.9 | 3.2 | 2.5 |
| Maximum peak of pulse current | I _{peak} | A | 12 | 19 | 22 | 27 |
| Thermal time constant | T _{th} | min | 30 (15) ⁵⁾ | 30 (15) ⁵⁾ | 30 (15) ⁵⁾ | 30 (15) ⁵⁾ |
| Mass ⁴⁾ | m _M | kg | 3.2 | 3.9 | 4.6 | 5.3 |
| | | | 063 A - - - RS | 063 B - - - JS | 063 C - - - HS | 063 D - - - FS |
| Nominal motor speed ¹⁾ | n | min ⁻¹ | 6000 | 6000 | 6000 | 6000 |
| Continuous torque at standstill ²⁾ | M _{dN} | Nm | 0.8 (1.0) ⁵⁾ | 1.5 (1.7) ⁵⁾ | 2.1(2.7) ⁵⁾ | 2.7 (3.5) ⁵⁾ |
| Continuous current at standstill | I _{dN} | A | 3.5 (4.4) ⁵⁾ | 5.8 (6.6) ⁵⁾ | 6.8 (8.7) ⁵⁾ | 8.4 (11.0) ⁵⁾ |
| Rotor moment of inertia ³⁾ | J _M | kgm ² | 2.4 x 10 ⁻⁴ | 3.2 x 10 ⁻⁴ | 4.0 x 10 ⁻⁴ | 4.8 x 10 ⁻⁴ |
| Torque constant at 20 °C | K _m | Nm/A | 0.230 | 0.26 | 0.31 | 0.32 |
| Windings resistance at 20 °C | R _A | Ohm | 3.7 | 1.6 | 1.1 | 0.7 |
| Windings inductance | L _A | mH | 3.5 | 1.5 | 1.2 | 0.9 |
| Maximum peak of pulse current | I _{peak} | A | 19 | 31 | 36 | 46 |
| Thermal time constant | T _{th} | min | 30 (15) ⁵⁾ | 30 (15) ⁵⁾ | 30 (15) ⁵⁾ | 30 (15) ⁵⁾ |
| Mass ⁴⁾ | m _M | kg | 3.2 | 3.9 | 4.6 | 5.3 |

¹⁾ The usable motor speed is determined by the drive used.
 Only those usable speeds n_{max} found in the selection lists of the motor-drive combinations are binding.
²⁾ With 60K overtemperature at the motor housing.
 Continuous torque can be limited by the drive. See selection data.
³⁾ With tacho-generator, without holding brake
⁴⁾ With tacho-generator, without holding brake, without blower.
⁵⁾ Parenthetical values apply to versions with surface cooling.

Fig 3.1: Type-dependent motor data

| Designation | Symbol | Unit | Data |
|---|-----------------|-------------------------------|--------------------------------|
| Permissible ambient temperature | T _{um} | °C | 0 ... + 45 |
| Permissible storage and transport temperature | T _L | °C | -20 ... +80 |
| Maximum installation elevation | | m | 1000 meters above sea level |
| Protection category | | | IP 65 ¹⁾ |
| Insulation classification | | | F |
| Housing coat | | | Black prime coat (RAL 9005) |
| Voltage constant of the tacho-generator | C _w | Vs/rad V/min ⁻¹ | 0,0143 1.5/1000 |

¹⁾ Except for the shaft leadthrough in drive shafts, without sealing ring. Protection category is then IP 50.

Fig 3.2: General data MAC 063

| Designation | Symbol | Unit | Data holding brake |
|---------------------|----------------|------------------|-------------------------------|
| Principle of action | | | electrically-actuated release |
| Holding torque | M _H | Nm | 3.0 |
| Nominal voltage | U _N | V | DC 24 ± 10% |
| Nominal current | I _N | A | 0.6 |
| Moment of inertia | J _B | kgm ² | 0.38 x 10 ⁻⁴ |
| Release delay | t _L | ms | 30 |
| Clamping delay | t _K | ms | 15 |
| Mass | m _B | kg | 0.55 |

Fig 3.3: Technical data - holding brake

| Designation | Symbol | Unit | Data surface cooling | |
|---|----------------|------|-----------------------------|-----------------------------|
| | | | Axial cooling | Radial cooling |
| Power consumption | S _N | VA | 20/18 | 16/14 |
| Nominal voltage | U _N | V | AC 230 or 115 ¹⁾ | AC 230 or 115 ¹⁾ |
| Frequency | f | Hz | 50/60 | 50/60 |
| Mass | m _L | kg | approx. 1.1 ²⁾ | approx. 1.0 ²⁾ |
| Protection category blower unit | | | IP 24 | IP 24 |
| Protection category blower motor | | | IP 44 | IP 44 |
| ¹⁾ 115 V special design ²⁾ Blower shroud for motor with tach feedback. | | | | |

Fig 3.4: Technical data - surface cooling

3.2. Torque-Speed Characteristics

MDD 063 A - - - ES
3500 min⁻¹

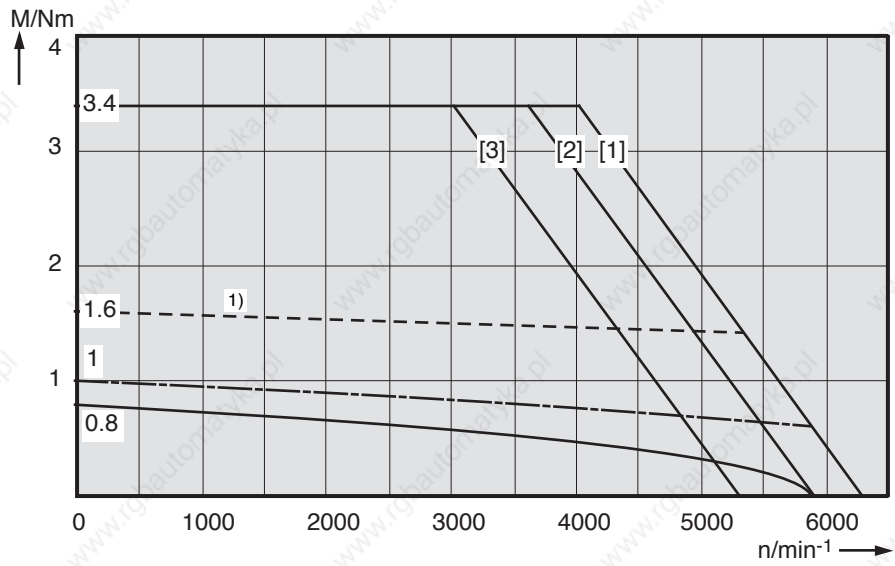

MDD 063 A - - - RS
6000 min⁻¹

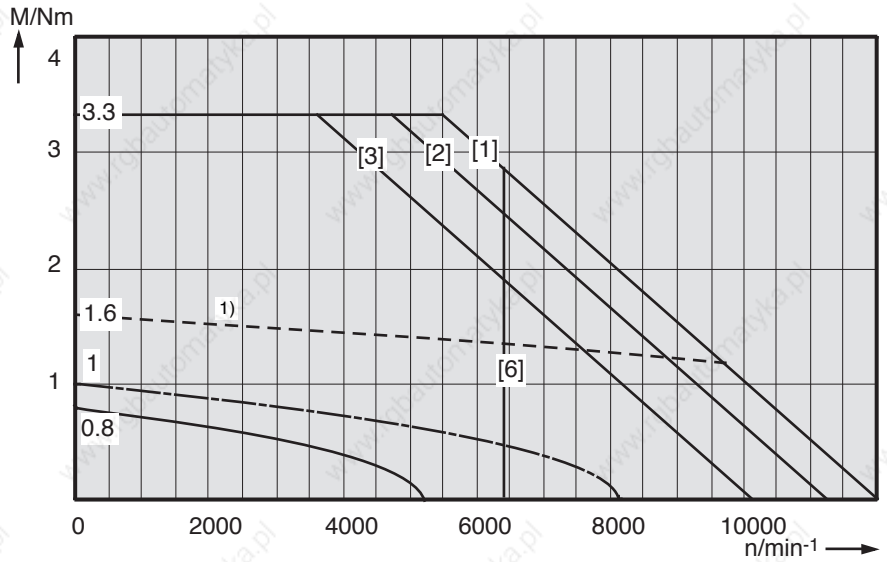

MDD 063 B - - - GS
3500 min⁻¹

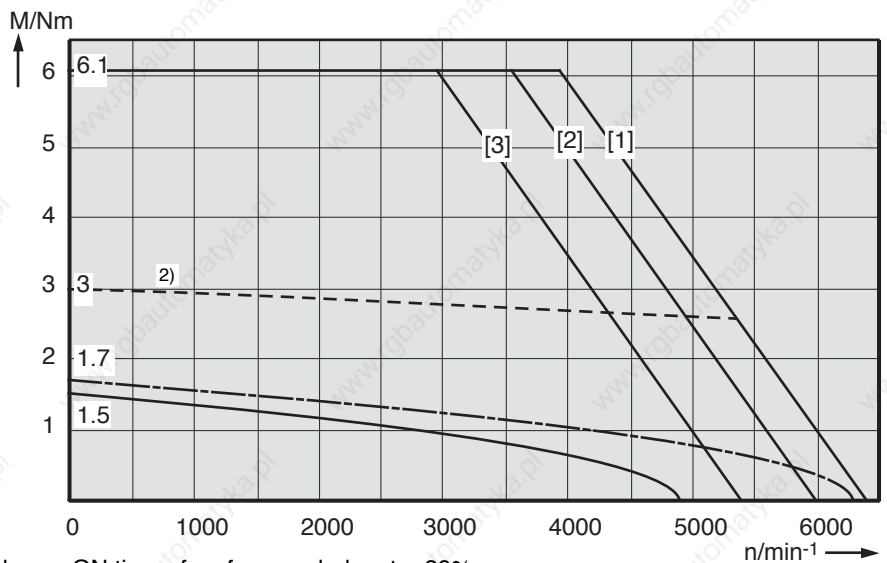

1) shown: ON time of surface-cooled motor 39%
2) shown: ON time of surface-cooled motor 32%

Fig 3.5: Torque-speed Characteristics MAC 063

MDD 063 B - · · - JS
6000 min⁻¹

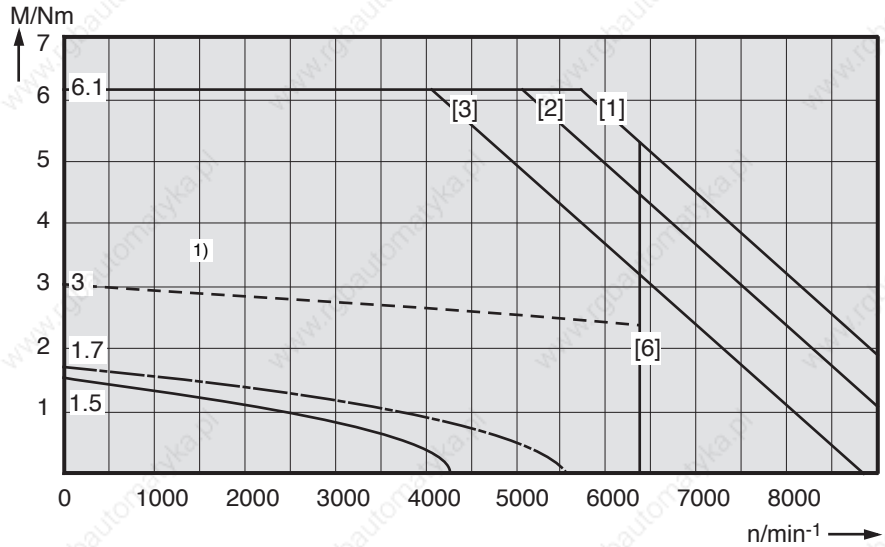

MDD 063 C - · · - MS
3500 min⁻¹

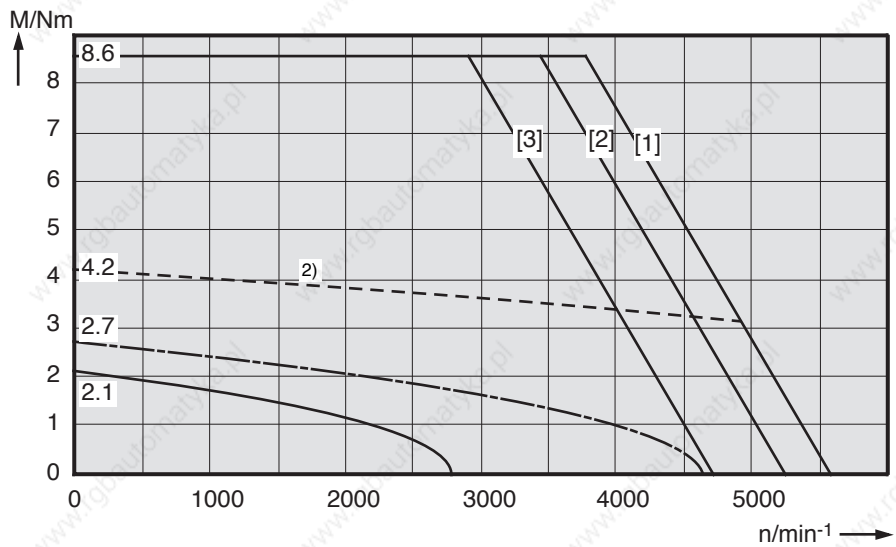

MDD 063 C - · · - HS
6000 min⁻¹

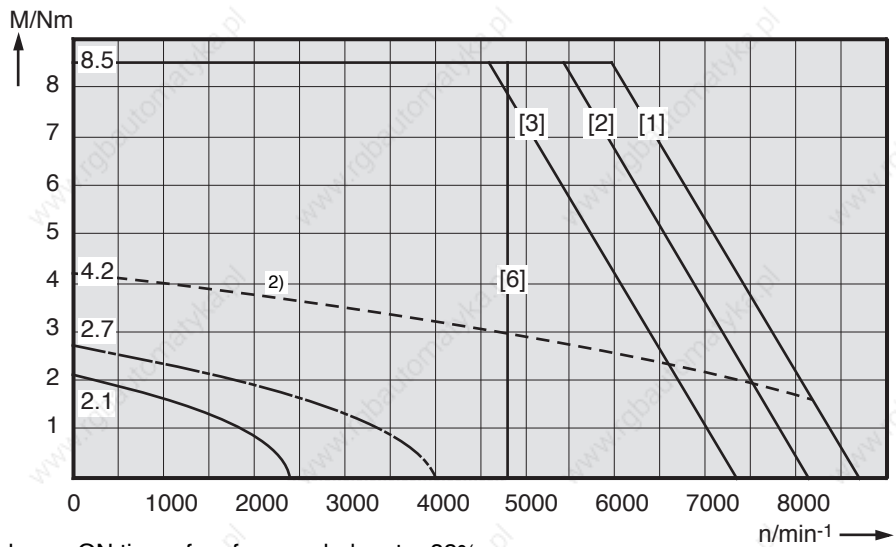

1) shown: ON time of surface-cooled motor 32%
2) shown: ON time of surface-cooled motor 41%

Fig 3.6: Torque-speed characteristics MAC 063

MDD 063 D - - - JS
3500 min⁻¹

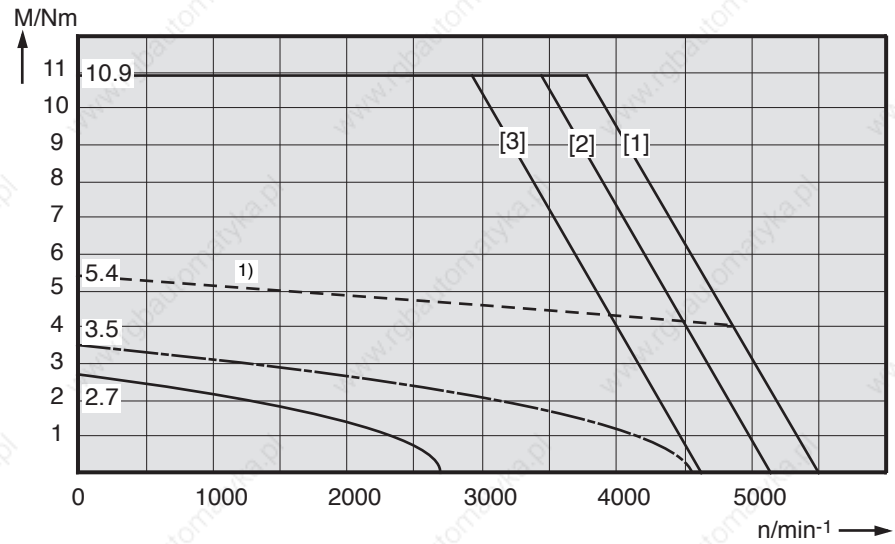

MDD 063 D - - - FS
6000 min⁻¹

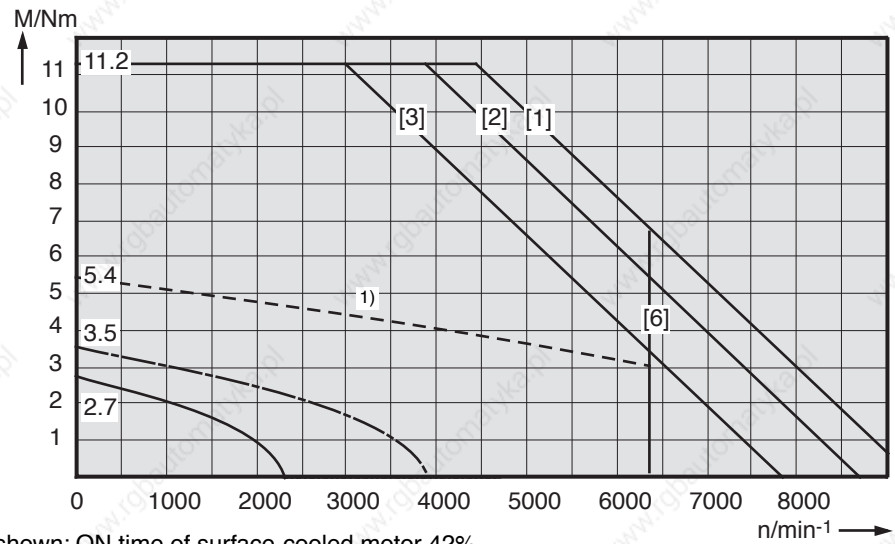

1) shown: ON time of surface-cooled motor 42%

Fig 3.7: Torque-speed characteristics MAC 063

3.3. Shaft Load Capacity

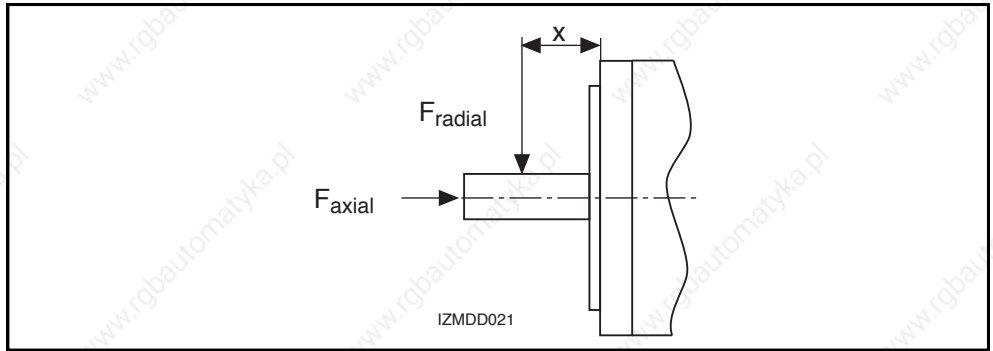

Fig 3.8: Shaft load

Permissible radial force
 F_{radial}

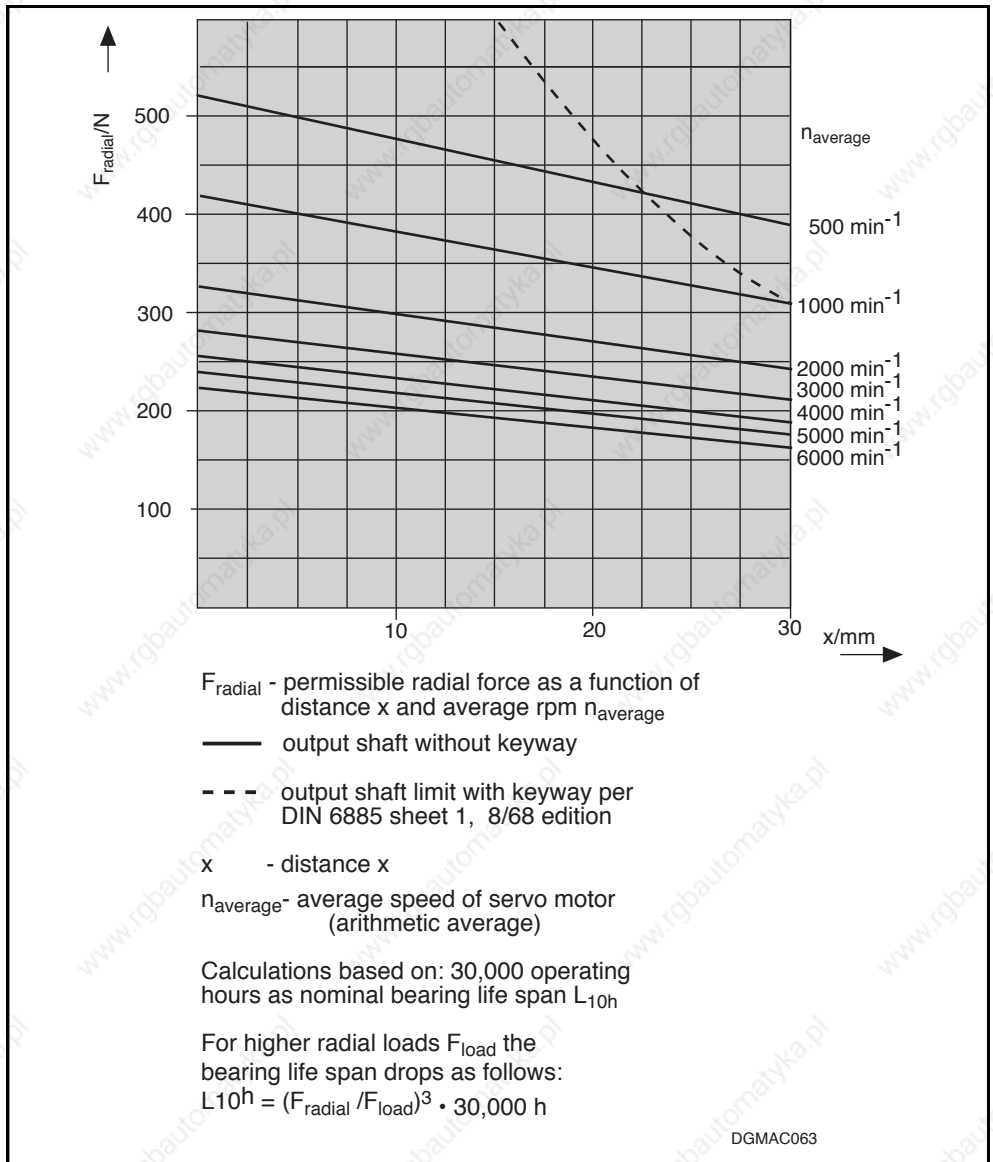

Fig 3.9: Permissible radial force

Permissible axial force
 F_{axial}

$$F_{axial} = 0.57 \cdot F_{radial}$$

F_{axial} - Permissible axial force

F_{radial} - Permissible radial force

3.4. Dimensional Data - Natural Convection

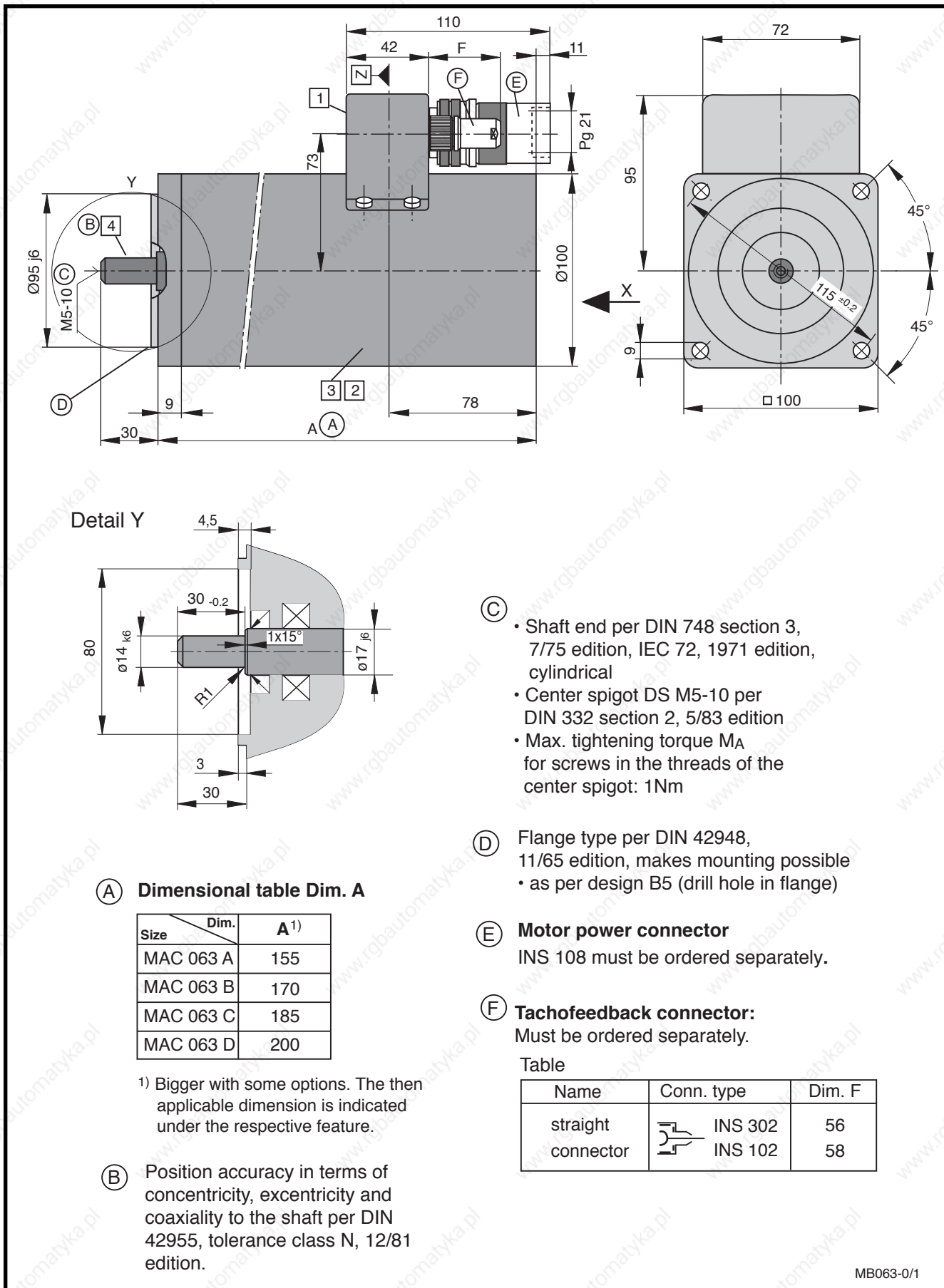

Fig 3.10: Dimensional data - MAC 063 (natural convection)

MB063-0/1

Available options

1 Power connection

The output direction of the electrical power connector is selected at the time the order is placed. Possible output directions are:

- to side A
- to side B

The drawing depicts side B as output direction. The dimensions of any other direction are obtained by a virtual turning of the connector housing around the Z axis.

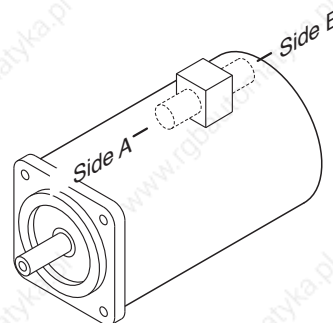

2 Motor version

- Tachofeedback and second shaft end

View X:

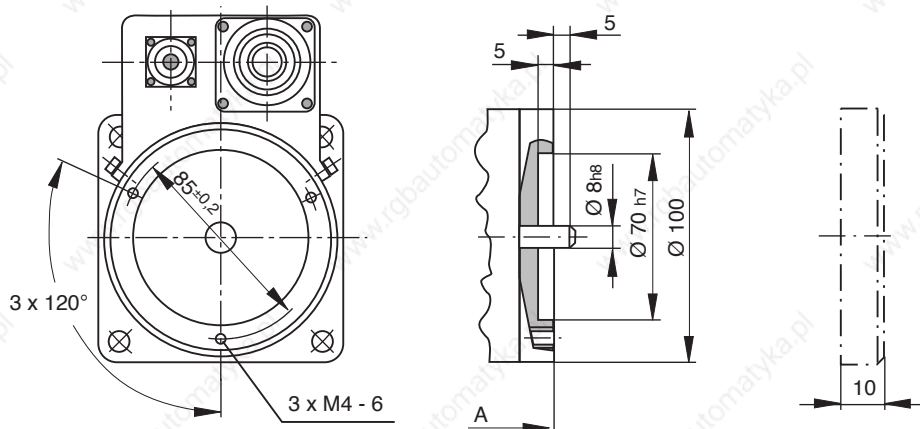

| Table | Dim. A |
|-----------|--------|
| MAC 063 A | 162.5 |
| MAC 063 B | 177.5 |
| MAC 063 C | 192.5 |
| MAC 063 D | 207.5 |

Cover mounted at delivery.

- Tachofeedback and mounted incremental encoder

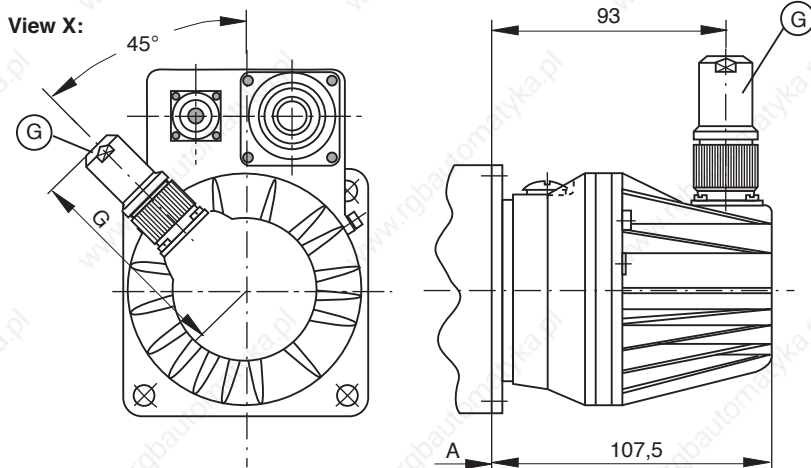

| Table | Dim. A |
|-----------|--------|
| MAC 063 A | 162.5 |
| MAC 063 B | 177.5 |
| MAC 063 C | 192.5 |
| MAC 063 D | 207.5 |

G Incremental encoder connector
Must be ordered separately.

| Name | Conn. type | Dim. G |
|----------------|--------------------|--------|
| straight conn. | INS 301 | 88 |
| | INS 101 | 90 |
| angle conn. | INS 351 INS 311 | 86 |

- Tachofeedback and mounted absolute encoder (see following page)

MB063-0/2

Fig 3.11: Dimensional data - MAC 063 - available options - (natural convection)

Available options

- Tachofeedback and mounted absolute encoder

View X:

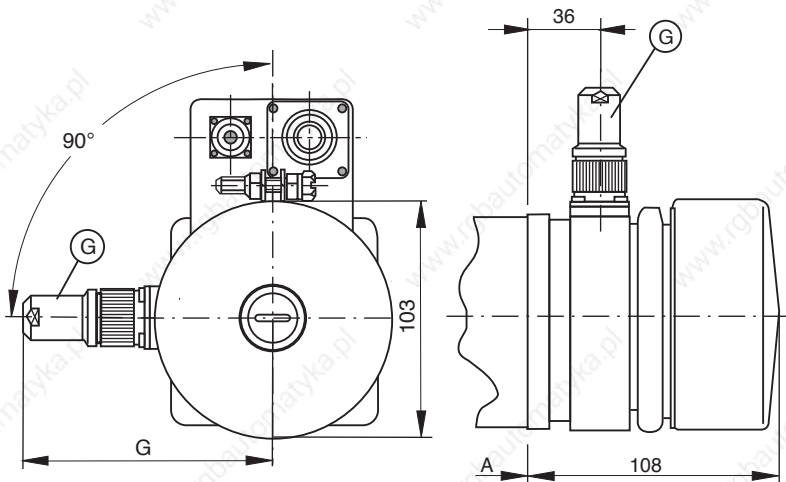

| Table | Dim. A |
|-----------|--------|
| MAC 063 A | 162.5 |
| MAC 063 B | 177.5 |
| MAC 063 C | 192.5 |
| MAC 063 D | 207.5 |

G Absolute encoder conn.
Must be ordered separately.

| Name | Conn. type | Dim. G |
|----------------|------------|--------|
| straight conn. | INS 326 | 104 |
| | INS 92 | 106 |
| angle conn. | INS 322 | 102 |

3 Blocking brake

- without blocking brake
Dim. A retained
- Standard blocking brake: 3 Nm

Table for blocking brake

| Dim. Size | Vers. 2 A | Vers. 3 & 4 A |
|-----------|-----------|---------------|
| MAC 063 A | 180 | 187.5 |
| MAC 063 B | 195 | 202.5 |
| MAC 063 C | 210 | 217.5 |
| MAC 063 D | 225 | 232.5 |

Vers. 2 = Motor with tachofeedback
 Vers. 3 = Motor with tachofeedback and second shaft end
 Vers. 4 = Motor with tachofeedback and mounted encoder

4 Output shaft

- plain shaft (recommended type)
- with keyway per DIN 6885 sh. 1, 8/68 edition
(Note! balanced with entire key.)

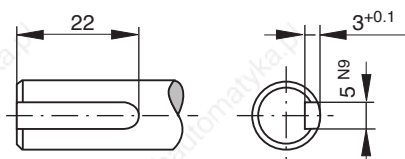

Matching key: DIN 6885-A 5 x 5 x 22
Must be ordered separately.

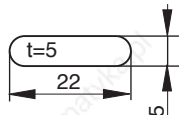

MB063-0/3

Fig 3.12: Dimensional data - MAC 063 - available options - (natural convection)

3.5. Dimensional Data - Radial Cooling

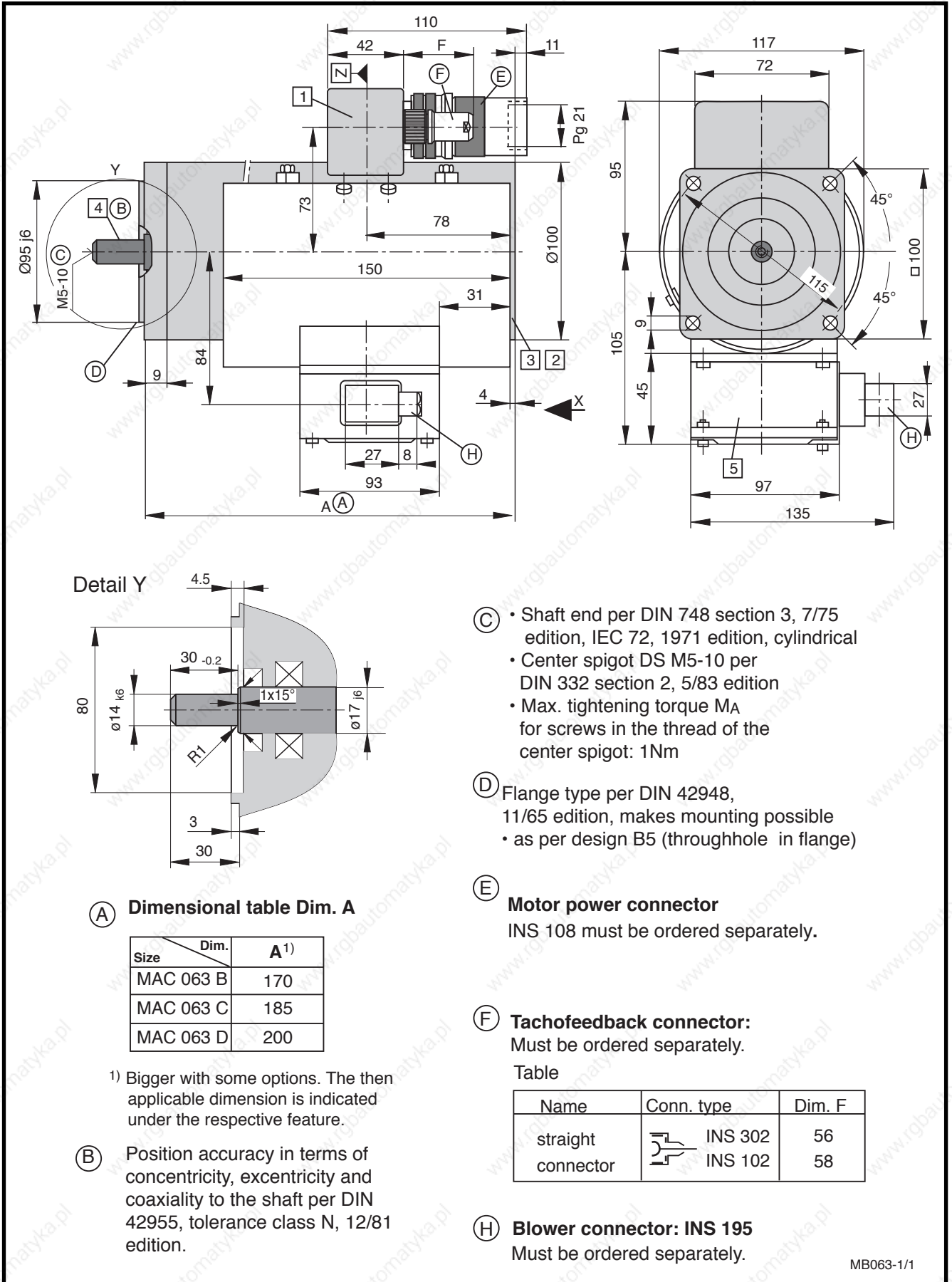

Fig 3.13: Dimensional data - MAC 063 (radial cooling)

Available options

1 Power connection

The output direction of the electrical power connector is selected at the time the order is placed. Possible output directions are:

- to side A
- to side B

The drawing depicts side B as output direction. The dimensions of any other direction are obtained by a virtual turning of the connector housing around the Z axis.

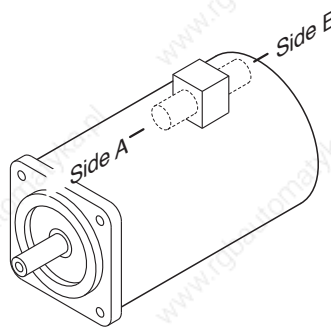

2 Motor version

- Tachofeedback and second shaft end

View X:

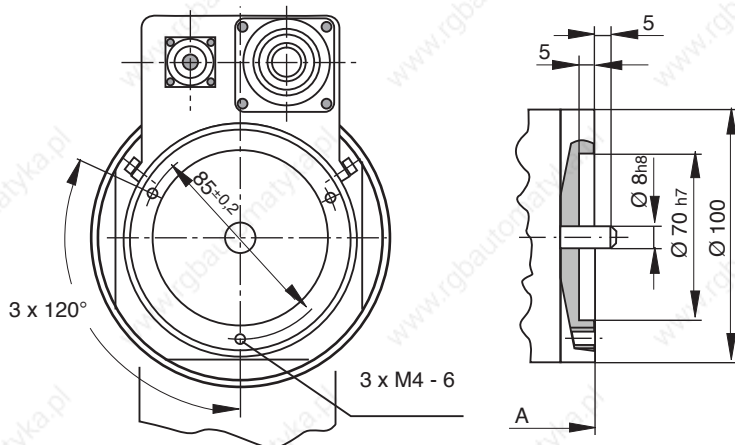

| Table | Dim. A |
|-----------|--------|
| MAC 063 B | 177.5 |
| MAC 063 C | 192.5 |
| MAC 063 D | 207.5 |

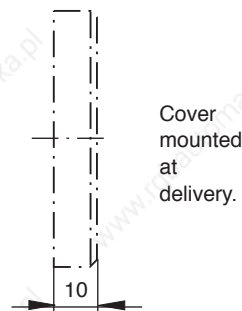

- Tachofeedback and mounted incremental encoder

View X:

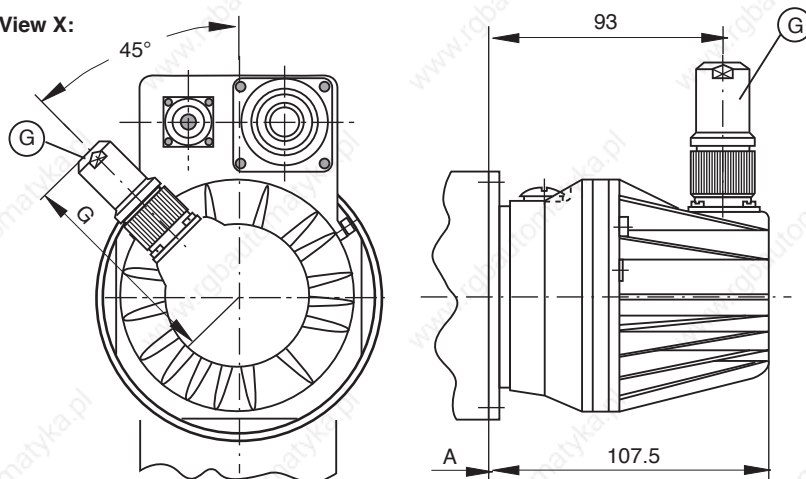

| Table | Dim. A |
|-----------|--------|
| MAC 063 B | 177.5 |
| MAC 063 C | 192.5 |
| MAC 063 D | 207.5 |

G Incremental encoder connector

Must be ordered separately.

| Name | Conn. type | Dim. G |
|----------------|--------------------|--------|
| straight conn. | INS 301 | 88 |
| | INS 101 | 90 |
| angle conn. | INS 351 INS 311 | 86 |

- Tachofeedback and mounted absolute encoder (see following page)

MB063-1/2

Fig 3.14: Dimensional data - MAC 063 - available options - (radial cooling)

Available options

- Tachofeedback and mounted absolute encoder

View X:

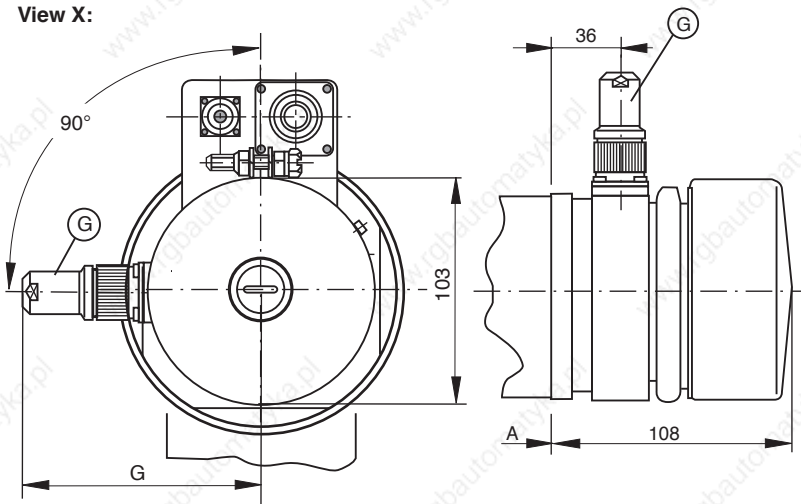

| Table | Dim. A |
|-----------|--------|
| MAC 063 B | 177.5 |
| MAC 063 C | 192.5 |
| MAC 063 D | 207.5 |

G Absolute encoder conn.
Must be ordered separately.

| Name | Conn. type | Dim. G |
|----------------|------------|--------|
| straight conn. | INS 326 | 104 |
| | INS 92 | 106 |
| angle conn. | INS 322 | 102 |

3 Blocking brake

- without blocking brake
Dim. A retained
- Standard blocking brake: 3 Nm

Table for blocking brake

| Dim. Size | Vers. 2 A | Vers. 3 & 4 A |
|-----------|-----------|---------------|
| MAC 063 B | 195 | 202.5 |
| MAC 063 C | 210 | 217.5 |
| MAC 063 D | 225 | 232.5 |

Vers. 2 = Motor with tachofeedback

Vers. 3 = Motor with tachofeedback and second shaft end

Vers. 4 = Motor with tachofeedback and mounted encoder

4 Output shaft

- plain shaft (recommended type)
- with keyway per DIN 6885 sh. 1, 8/68 edition
(Note! balanced with entire key.)

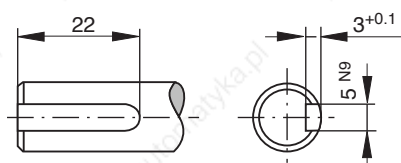

Matching key: DIN 6885-A 5 x 5 x 22
Must be ordered separately.

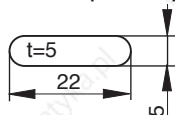

5 Blower arrangement

Looking towards motor shaft.

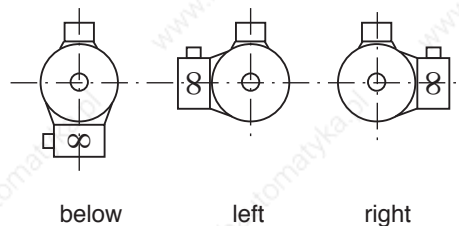

MB063-1/3

Fig 3.15: Dimensional data - MAC 063 - available options - (radial cooling)

3.6. Dimensional Data - Axial Cooling

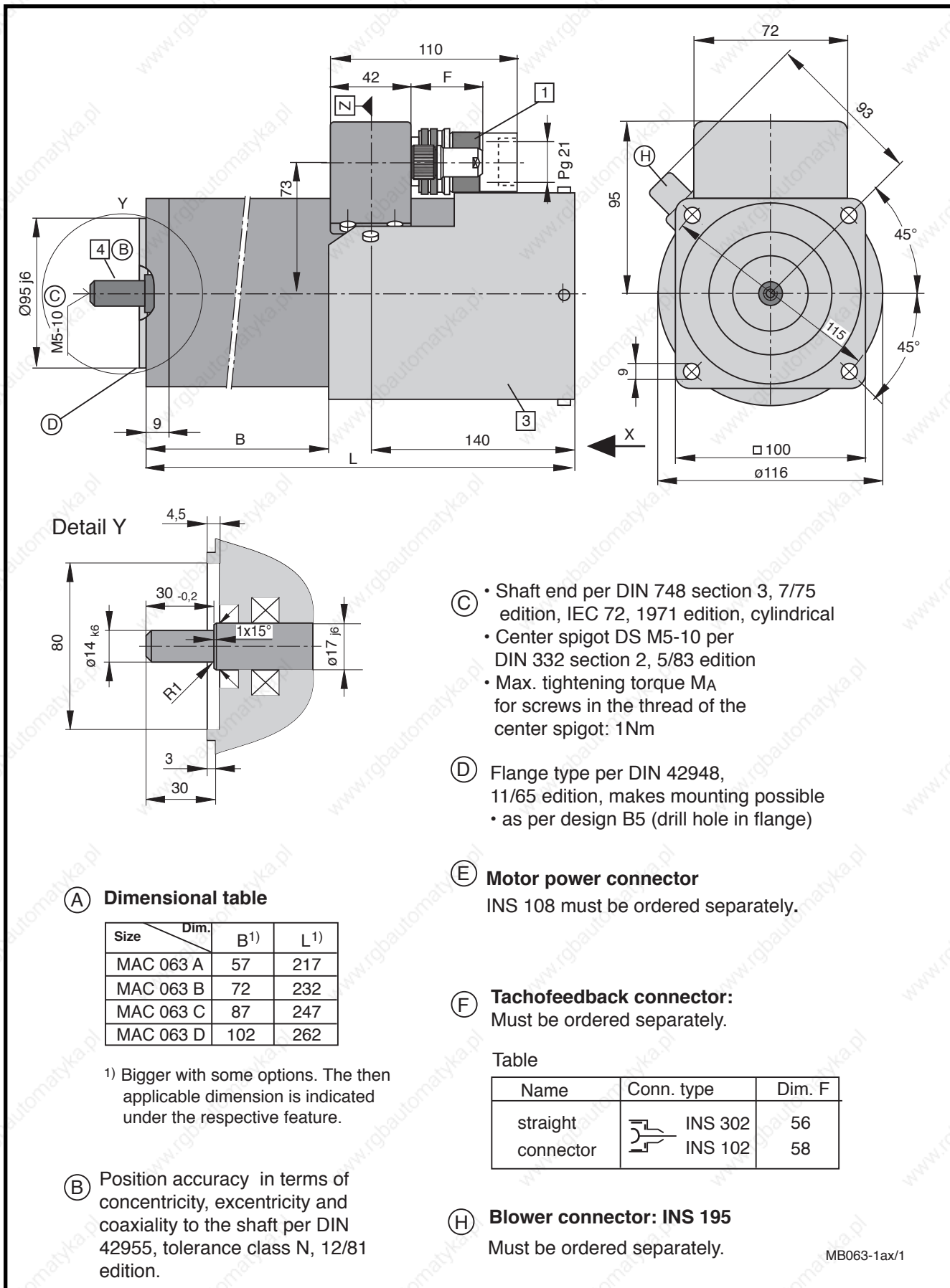

Fig 3.16: Dimensional data - MAC 063 (axial cooling)

MB063-1ax/1

Available options

1 Power connection

The output direction of the electrical power connector is selected at the time the order is placed. Possible output directions are:

- to side A
- to side B

The drawing depicts side B as output direction. The dimensions of any other direction are obtained by a virtual turning of the connector housing around the Z axis.

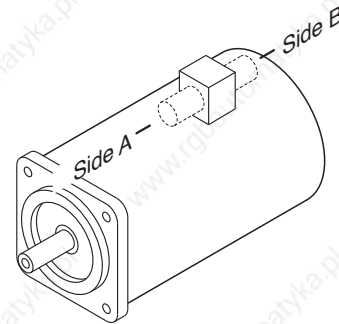

3 Blocking brake

- without brake, dimensions B and L are retained
- Standard blocking brake: 3 Nm

Table with blocking brake
3 Nm holding torque:

| Size | Dim. | B | L |
|-----------|------|-----|-----|
| MAC 063 A | | 82 | 242 |
| MAC 063 B | | 97 | 257 |
| MAC 063 C | | 112 | 272 |
| MAC 063 D | | 127 | 287 |

4 Output shaft

- plain shaft (preferred type)
- with keyway per DIN 6885 sheet 1, 8/68 edition
(Note! balanced with entire key.)

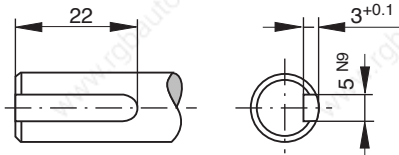

Matching key: DIN 6885-A 5 x 5 x 22
Must be ordered separately.

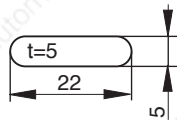

MB063-1ax/2

Fig 3.17: Dimensional data - MAC 063 - available options - (axial cooling)

3.7. Available Options

| Type code fields | | Example: | MAC 063 A-0-RS-4 - C/095-A-0/WI 520LV/S000 | |
|--|--|-----------------------------|---|----|
| 1. Motor for analogue drives | | MAC | | |
| 2. Motor size | | 063 | | |
| 3. Motor length | | A, B, C, D | | |
| 4. Type of cooling: | | | | |
| natural convection | | surface cooling | | |
| 0 | axial | | radial | |
| | | | blower right blower below blower left | |
| | AC 230 V 1 ¹⁾ | AC 115 V 2 ¹⁾ | AC 230 V 6 ³⁾ AC 115 V A ³⁾ AC 230 V 7 ³⁾ AC 115 V B ³⁾ AC 230 V 8 ³⁾ AC 115 V C ³⁾ | |
| 5. Type of windings | | | | |
| Nominal rpm | Motor length | | | |
| | A | B | C | D |
| | 3500 min ⁻¹ | ES | GS | MS |
| 6000 min ⁻¹ | RS | JS | HS | FS |
| 6. Motor feedback | | | | |
| Motor type | | | | |
| with tachofeedback | | | 2 | |
| with tachofeedback and second shaft end | | | 3 | |
| with tachofeedback and mounted incremental or absolute encoder | | | 4 | |
| Tacho voltage | | | | |
| set to nominal motor speed: 1.5 V/1000 min ⁻¹ | | | - | |
| Tacho type | | | | |
| standard | | | C | |
| increased smooth run quality | | | F | |
| 7. Centering diameter | | | | |
| for design B05 | | | 095 | |
| 8. Power connection | | | | |
| connector to side A | | | A | |
| connector to side B | | | B | |
| 9. Blocking brake | | | | |
| without blocking brake | | | 0 | |
| with standard blocking brake (3 Nm) | | | 1 | |
| Mounted encoder | 10. Type ²⁾ | | | |
| | Incremental encoder with standard mounting | | WI | |
| | Absolute encoder | | AM | |
| 11. Encoder code ²⁾ | | | | |
| For available types, see section 2.4 "Motor feedback" | | | | |
| 12. Special types | | | | |
| Fixed and documented by INDRAMAT with special number (see Drawing no.: 106-0105-4301-XX) | | | | |
| Does not apply to standard motors. | | | | |

Fig 3.18: Type codes - MAC 063

TLMAC063

3.8. Special options

| Specification of Option | S001 | S006 | S007 |
|-----------------------------------|------|------|------|
| with keyway per DIN 6885, sheet 1 | X | | X |
| output shaft with shaft sealing | | X | X |

Fig 3.19: Special options with a MAC 063

Empty page

4. MAC 071

4.1. Technical Data

| Designation | Symbol | Unit | Motor type MAC ... | | |
|---|-------------------|-------------------|--------------------------|---------------------------|---------------------------|
| | | | 071 A - - - HS | 071 B - - - FS | 071 C - - - US |
| Nominal motor speed ¹⁾ | n | min ⁻¹ | 2000 | 2000 | 2000 |
| Continuous torque at standstill ²⁾ | M _{dN} | Nm | 2.2 (3.3) ⁵⁾ | 4.4 (6.6) ⁵⁾ | 6.6 (9.9) ⁵⁾ |
| Continuous current at standstill | I _{dN} | A | 2.6 (4.1) ⁵⁾ | 5.0 (7.9) ⁵⁾ | 7.3 (11.8) ⁵⁾ |
| Rotor moment of inertia ³⁾ | J _M | kgm ² | 5.4 x 10 ⁻⁴ | 9.9 x 10 ⁻⁴ | 12.9 x 10 ⁻⁴ |
| Torque constant at 20 °C | K _m | Nm/A | 0.860 | 0.880 | 0.900 |
| Windings resistance at 20 °C | R _A | Ohm | 7.6 | 2.7 | 1.6 |
| Windings inductance | L _A | mH | 42 | 22 | 15 |
| Maximum peak of pulse current | I _{peak} | A | 13 | 25 | 37 |
| Thermal time constant | T _{th} | min | 45 (20) ⁵⁾ | 45 (20) ⁵⁾ | 45 (20) ⁵⁾ |
| Mass ⁴⁾ | m _M | kg | 6.5 | 8.8 | 11 |
| | | | 071 A - - - OS | 071 B - - - TS | 071 C - - - NS |
| Nominal motor speed ¹⁾ | n | min ⁻¹ | 3000 | 3000 | 3000 |
| Continuous torque at standstill ²⁾ | M _{dN} | Nm | 2.2 (3.3) ⁵⁾ | 4.4 (6.6) ⁵⁾ | 6.6 (9.9) ⁵⁾ |
| Continuous current at standstill | I _{dN} | A | 3.8 (6.0) ⁵⁾ | 7.3 (11.7) ⁵⁾ | 11.0 (17.7) ⁵⁾ |
| Rotor moment of inertia ³⁾ | J _M | kgm ² | 5.4 x 10 ⁻⁴ | 9.9 x 10 ⁻⁴ | 12.9 x 10 ⁻⁴ |
| Torque constant at 20 °C | K _m | Nm/A | 0.580 | 0.600 | 0.600 |
| Windings resistance at 20 °C | R _A | Ohm | 3.5 | 1.24 | 0.69 |
| Windings inductance | L _A | mH | 20 | 10 | 7 |
| Maximum peak of pulse current | I _{peak} | A | 19 | 37 | 55 |
| Thermal time constant | T _{th} | min | 45 (20) ⁵⁾ | 45 (20) ⁵⁾ | 45 (20) ⁵⁾ |
| Mass ⁴⁾ | m _M | kg | 6.5 | 8.8 | 11 |
| | | | 071 A - - - ES | 071 B - - - PS | 071 C - - - JS |
| Nominal motor speed ¹⁾ | n | min ⁻¹ | 4000 | 4000 | 4000 |
| Continuous torque at standstill ²⁾ | M _{dN} | Nm | 2.2 (3.3) ⁵⁾ | 4.4 (6.6) ⁵⁾ | 6.6 (9.9) ⁵⁾ |
| Continuous current at standstill | I _{dN} | A | 5.0 (7.9) ⁵⁾ | 9.6 (15.3) ⁵⁾ | 15.3 (24.8) ⁵⁾ |
| Rotor moment of inertia ³⁾ | J _M | kgm ² | 5.4 x 10 ⁻⁴ | 9.9 x 10 ⁻⁴ | 12.9 x 10 ⁻⁴ |
| Torque constant at 20 °C | K _m | Nm/A | 0.440 | 0.460 | 0.430 |
| Windings resistance at 20 °C | R _A | Ohm | 2.0 | 0.72 | 0.35 |
| Windings inductance | L _A | mH | 11 | 5.9 | 3.5 |
| Maximum peak of pulse current | I _{peak} | A | 25 | 48 | 77 |
| Thermal time constant | T _{th} | min | 45 (20) ⁵⁾ | 45 (20) ⁵⁾ | 45 (20) ⁵⁾ |
| Mass ⁴⁾ | m _M | kg | 6.5 | 8.8 | 11 |
| | | | 071 A - - - VS | 071 B - - - KS | 071 C - - - GS |
| Nominal motor speed ¹⁾ | n | min ⁻¹ | 6000 | 6000 | 6000 |
| Continuous torque at standstill ²⁾ | M _{dN} | Nm | 2.2 (3.3) ⁵⁾ | 4.4 (6.6) ⁵⁾ | 6.6 (9.9) ⁵⁾ |
| Continuous current at standstill | I _{dN} | A | 7.3 (11.7) ⁵⁾ | 14.2 (22.3) ⁵⁾ | 22.0 (35.4) ⁵⁾ |
| Rotor moment of inertia ³⁾ | J _M | kgm ² | 5.4 x 10 ⁻⁴ | 9.9 x 10 ⁻⁴ | 12.9 x 10 ⁻⁴ |
| Torque constant at 20 °C | K _m | Nm/A | 0.300 | 0.310 | 0.300 |
| Windings resistance at 20 °C | R _A | Ohm | 0.92 | 0.34 | 0.17 |
| Windings inductance | L _A | mH | 5.1 | 2.8 | 1.7 |
| Maximum peak of pulse current | I _{peak} | A | 37 | 71 | 110 |
| Thermal time constant | T _{th} | min | 45 (20) ⁵⁾ | 45 (20) ⁵⁾ | 45 (20) ⁵⁾ |
| Mass ⁴⁾ | m _M | kg | 6.5 | 8.8 | 11 |

¹⁾ The usable motor speed is determined by the drive used.
 Only those usable speeds n_{max} found in the selection lists of the motor-drive combinations are binding.
²⁾ With 60K overtemperature at the motor housing.
 Continuous torque can be limited by the drive. See selection data.
³⁾ With tacho-generator, without holding brake
⁴⁾ With tacho-generator, without holding brake, without blower.
⁵⁾ Parenthetical values apply to versions with surface cooling.

Fig 4.1: Type-dependent motor data

| Designation | Symbol | Unit | Data | |
|--|----------|-------------------------------|-----------------------------|------------------|
| Permissible ambient temperature | T_{um} | °C | 0 ... + 45 | |
| Permissible storage and transport temperature | T_L | °C | -20 ... +80 | |
| Maximum installation elevation | | m | 1000 meters above sea level | |
| Protection category | | | IP 65 | |
| Insulation classification | | | F | |
| Housing coat | | | Black prime coat (RAL 9005) | |
| Voltage constant of the tachogenerator ¹⁾ | C_w | Vs/rad V/min ⁻¹ | 0,0143 1.5/1000 | 0.0286 3/1000 |

¹⁾ Tacho voltage can be selected application-related.

Fig 4.2: General data MAC 071

| Designation | Symbol | Unit | Data holding brake | |
|---------------------|--------|------------------|-------------------------|-------------------------------|
| | | | Standard | heavy-duty |
| Principle of action | | | | electrically-actuated release |
| Holding torque | M_H | Nm | 3.0 | 6.5 |
| Nominal voltage | U_N | V | | DC 24 ± 10% |
| Nominal current | I_N | A | 0.6 | 0.7 |
| Moment of inertia | J_B | kgm ² | 0.38 x 10 ⁻⁴ | 1.06 x 10 ⁻⁴ |
| Release delay | t_L | ms | 30 | 60 |
| Clamping delay | t_K | ms | 15 | 20 |
| Mass | m_B | kg | 0.3 | 0.5 |

Fig 4.3: Technical data - holding brake

| Designation | Symbol | Unit | Axial cooling | Radial cooling |
|----------------------------------|--------|------|-----------------------------|-----------------------------|
| Power consumption | S_N | VA | 22/22 | 22/22 |
| Nominal voltage | U_N | V | AC 230 or 115 ¹⁾ | AC 230 or 115 ¹⁾ |
| Frequency | f | Hz | 50/60 | 50/60 |
| Mass | m_L | kg | approx. 0.8 ²⁾ | approx. 0.7 ²⁾ |
| Protection category blower unit | | | IP 24 | IP 24 |
| Protection category blower motor | | | IP 44 | IP 44 |

¹⁾ 115 V special design
²⁾ Blower shroud for motor with tacho feedback.

Fig 4.4: Technical data - surface cooling

4.2. Torque-Speed Characteristics

MAC 071 A - - - HS
2000 min⁻¹

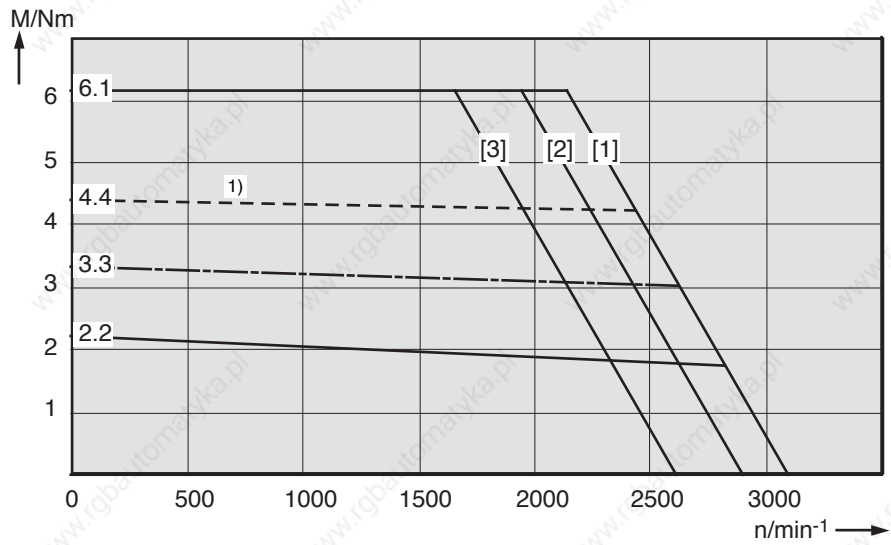

MAC 071 A - - - OS
3000 min⁻¹

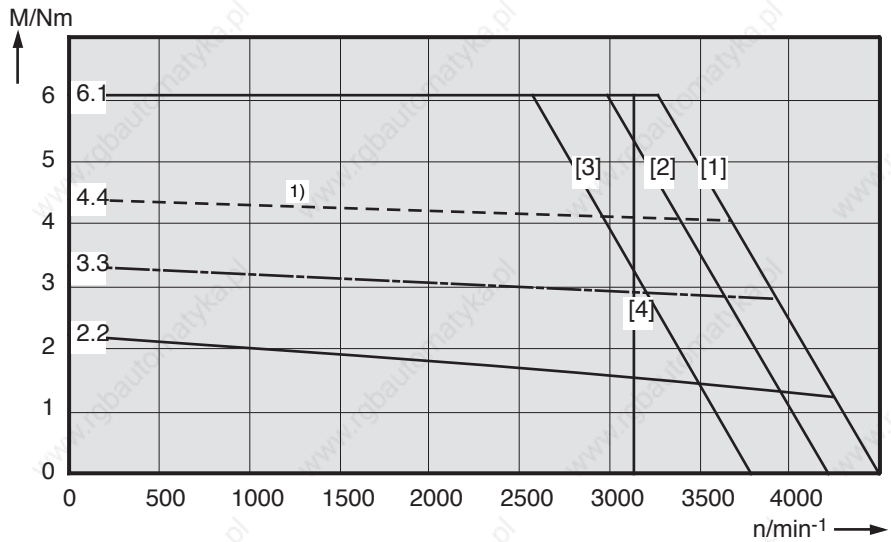

¹⁾ shown: ON time of surface-cooled motor 56%

Fig 4.5: Torque-speed characteristics MAC 071

MAC 071 A - - - ES
4000 min⁻¹

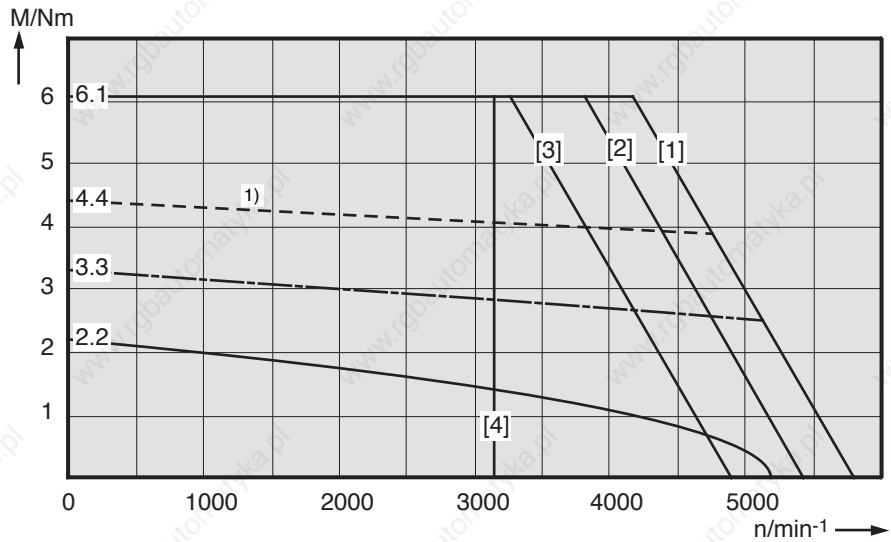

MAC 071 A - - - VS
6000 min⁻¹

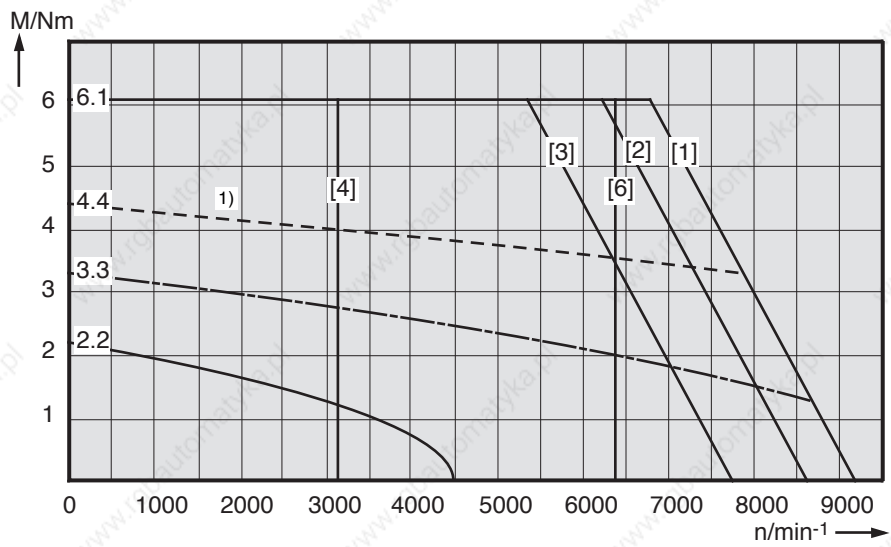

1) shown: ON time of surface-cooled motor 56%

Fig 4.6: Torque-speed characteristics MAC 071

MAC 071 B - • - FS
2000 min⁻¹

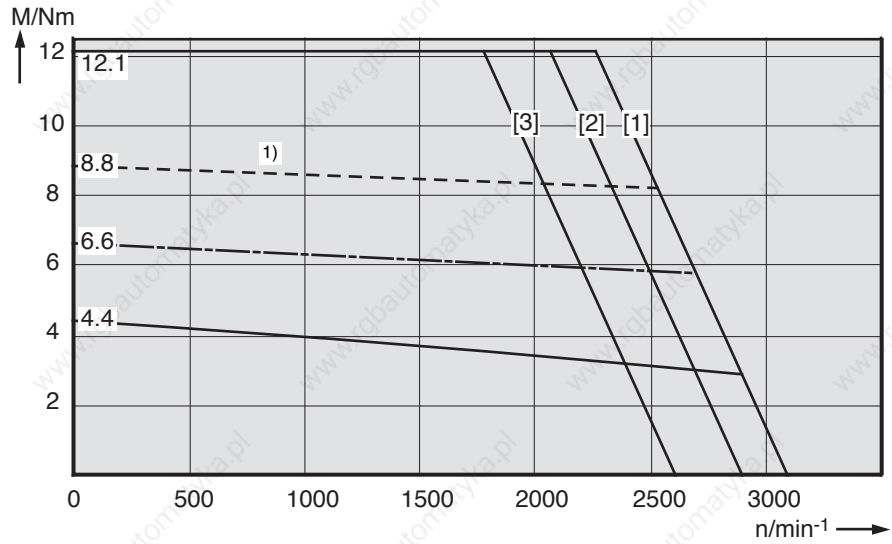

MAC 071 B - • - TS
3000 min⁻¹

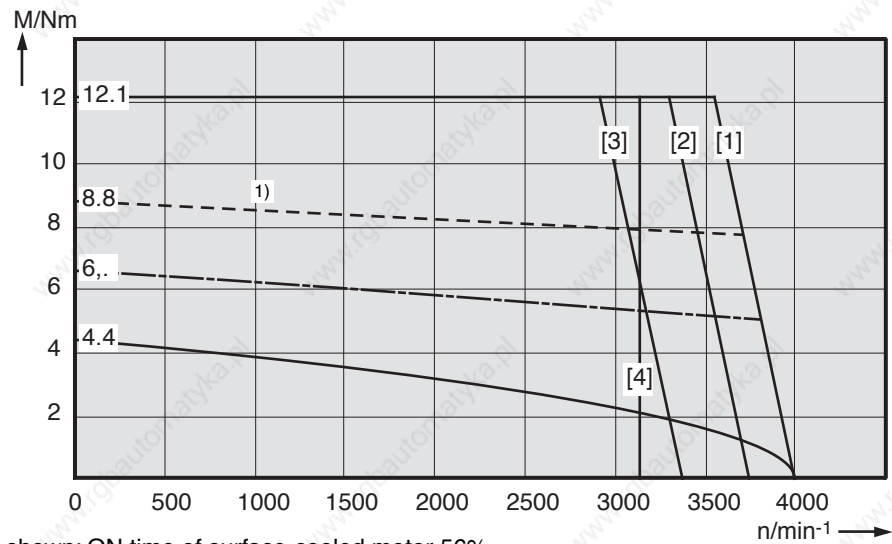

¹⁾ shown: ON time of surface-cooled motor 56%

Fig 4.7: Torque-speed characteristics MAC 071

MAC 071 B - - - PS
4000 min⁻¹

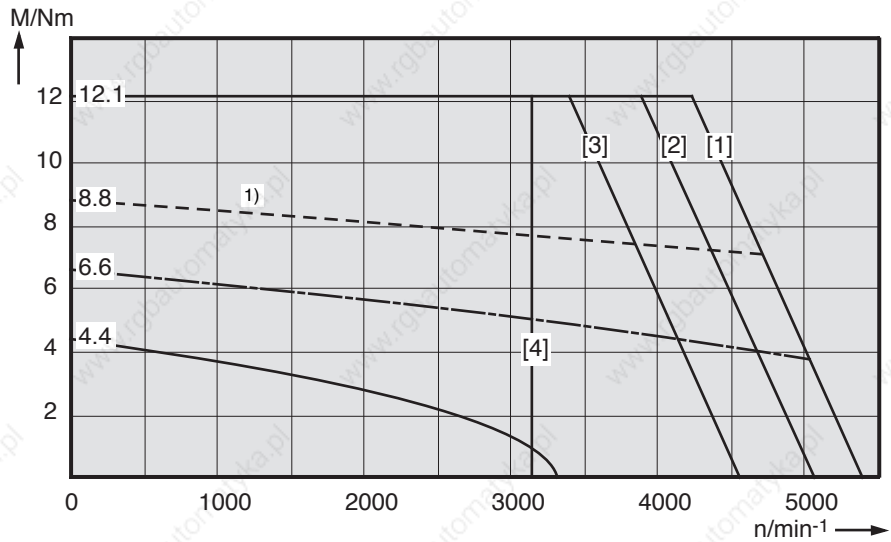

MAC 071 B - - - KS
6000 min⁻¹

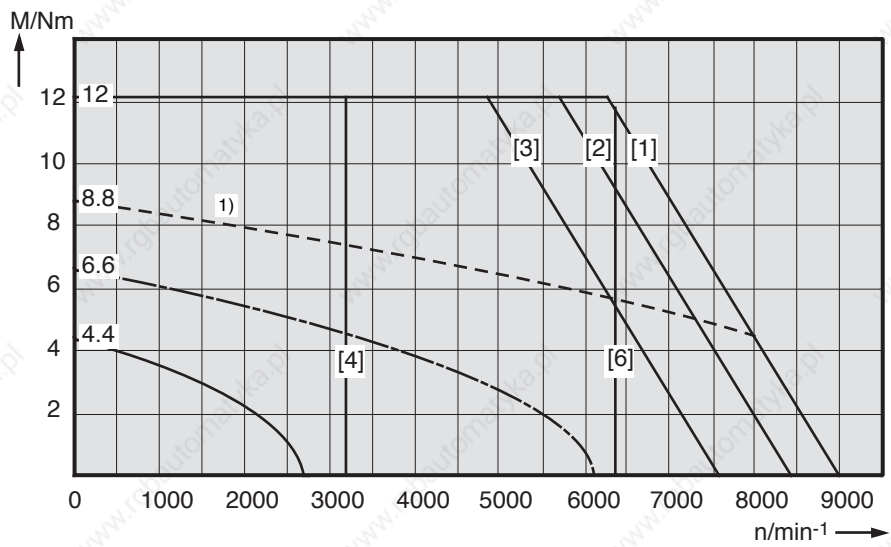

1) shown: ON time of surface-cooled motor 56%

Fig 4.8: Torque-speed characteristics MAC 071

MAC 071 C - - - US
2000 min⁻¹

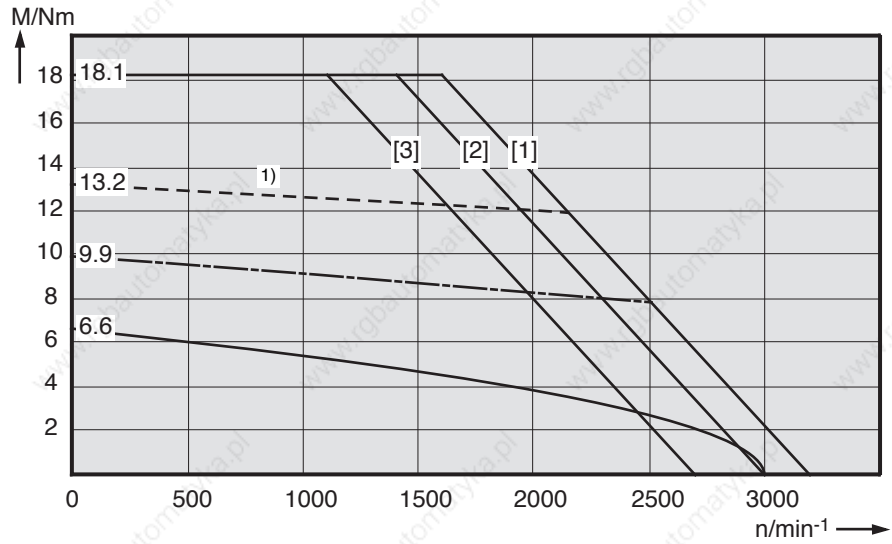

MAC 071 C - - - NS
3000 min⁻¹

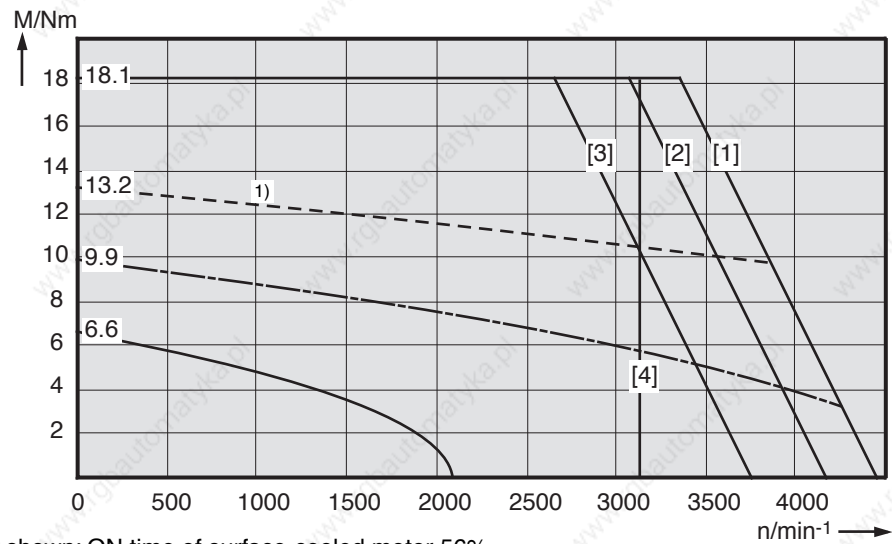

¹⁾ shown: ON time of surface-cooled motor 56%

Fig 4.9: Torque-speed characteristics MAC 071

MAC 071 C - - - JS
4000 min⁻¹

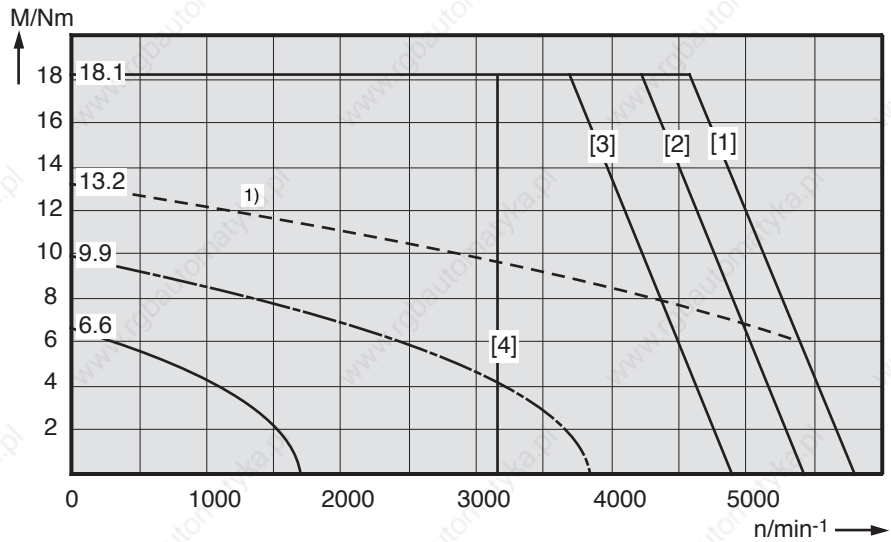

MAC 071 C - - - GS
6000 min⁻¹

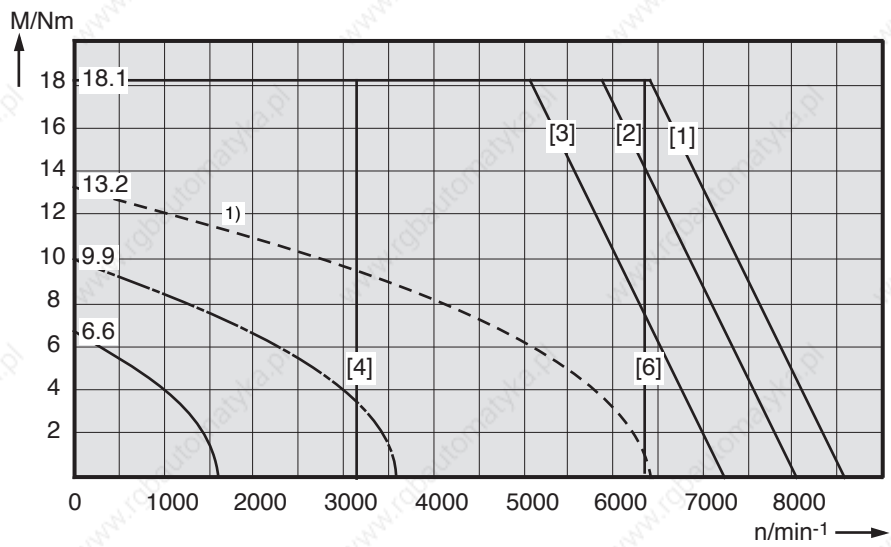

1) shown: ON time of surface-cooled motor 56%

Fig 4.10: Torque-speed characteristics characteristics MAC 071

4.3. Shaft Load Capacity

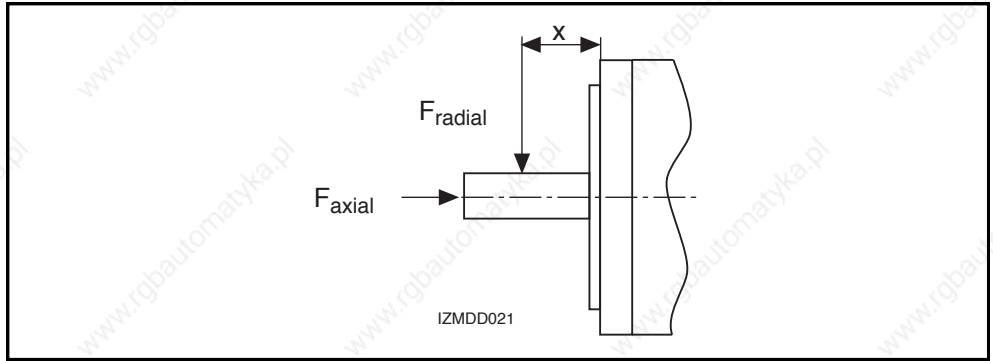

Fig 4.11: Shaft load

Permissible radial force

F_{radial}

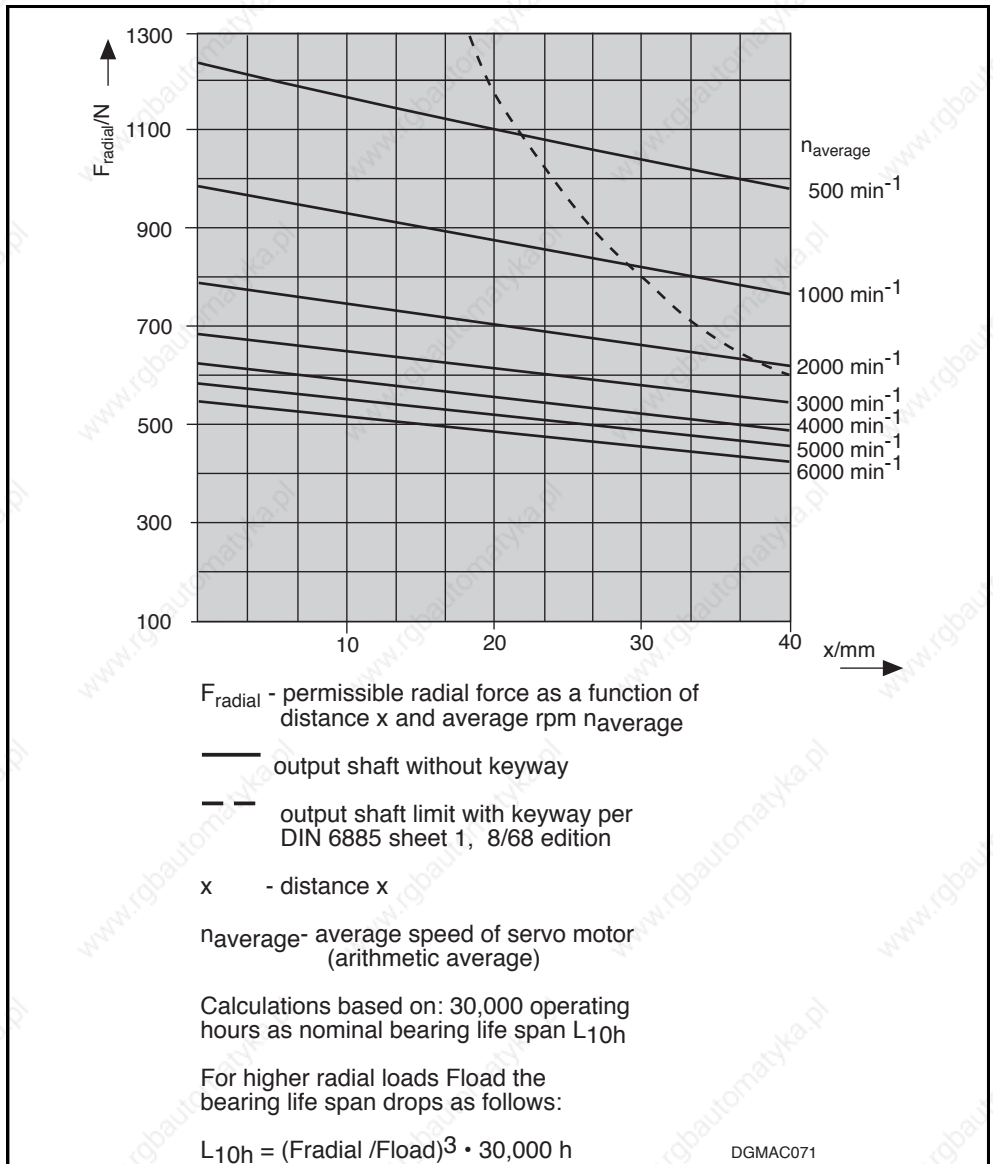

Fig 4.12: Permissible radial force

Permissible axial force

F_{axial}

$$F_{axial} = 0.50 \cdot F_{radial}$$

F_{axial} - Permissible axial force

F_{radial} - Permissible radial force

4.4. Dimensional Data - Natural Convection

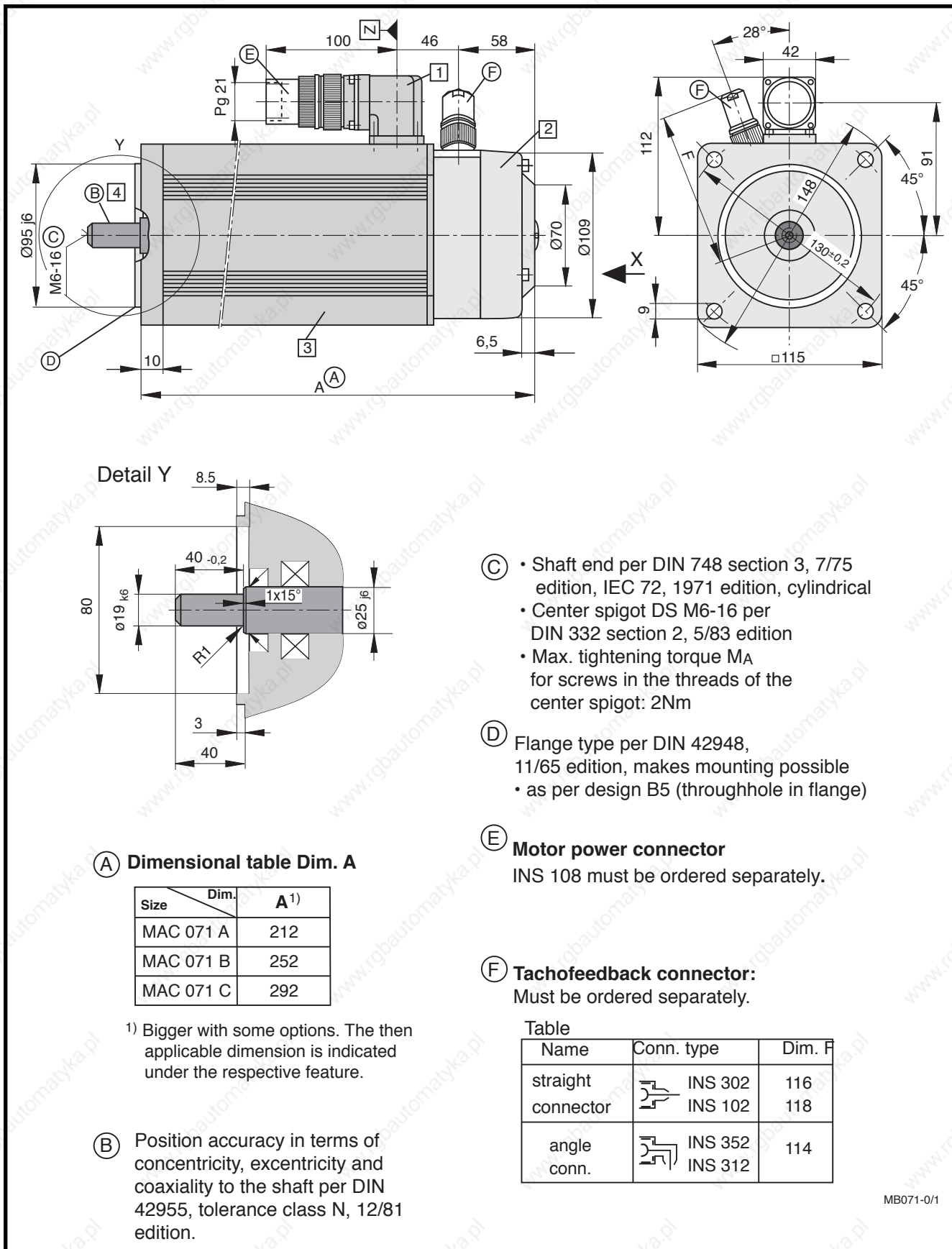

Fig 4.13: Dimensional data - MAC 071 (natural convection)

Available options

1 Power connection

The output direction of the electrical power connector is selected at the time the order is placed. Possible output directions are:

- to side A
- to side B
- to the right
- to the left

The drawing depicts side A as output direction. The dimensions of any other direction are obtained by a virtual turning of the connector housing around the Z axis.

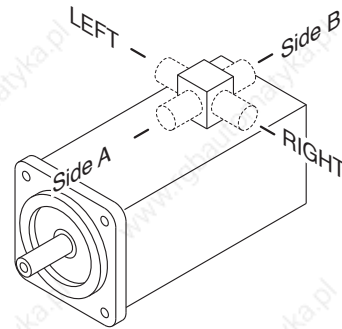

2 Motor version

- Tachofeedback and second shaft end

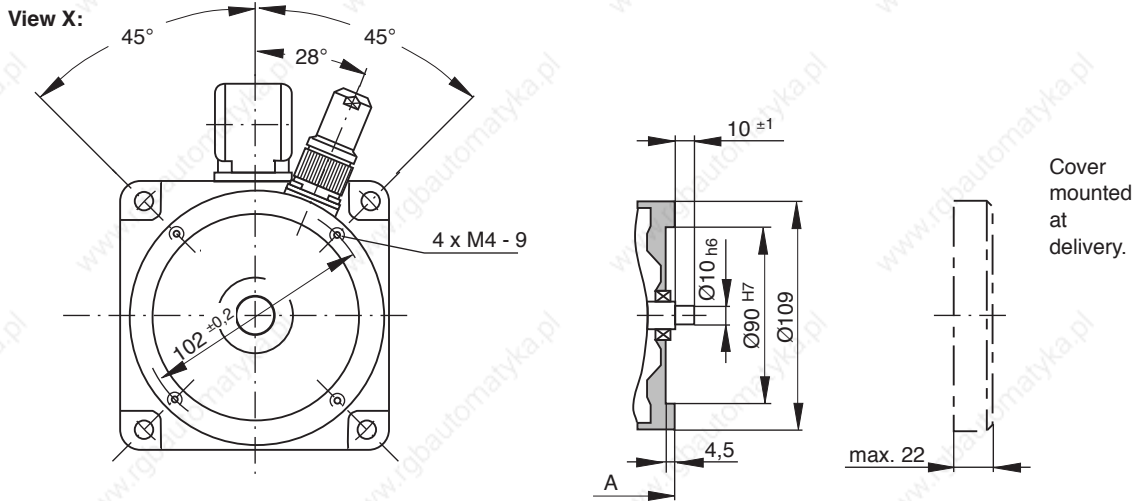

- Tachofeedback and mounted incremental encoder

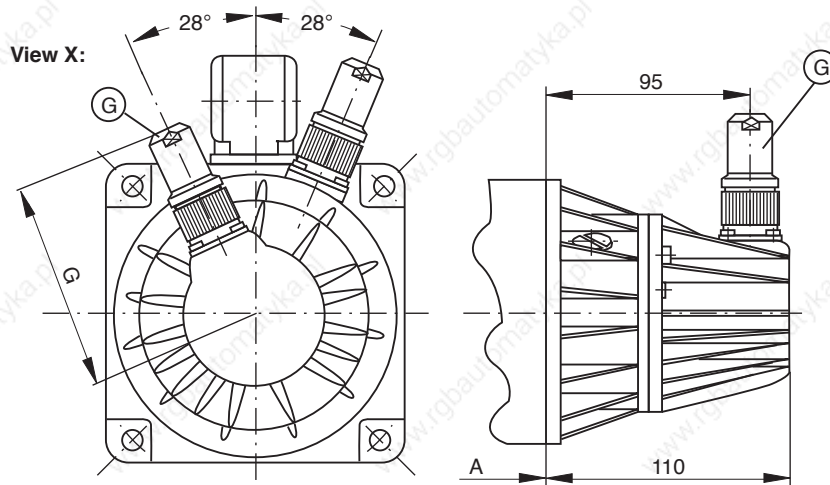

Incremental encoder connector

Must be ordered separately.

| Name | Conn. type | Dim. G |
|----------------|------------|--------|
| straight conn. | INS 301 | 88 |
| | INS 101 | 90 |
| angle conn. | INS 351 | 86 |
| | INS 311 | |

- Tachofeedback and mounted absolute encoder (see following page)

MB071-0/2

Fig 4.14: Dimensional data - MAC 071 - available options - (natural convection)

Available options

- Tachofeedback and mounted absolute encoder

View X:

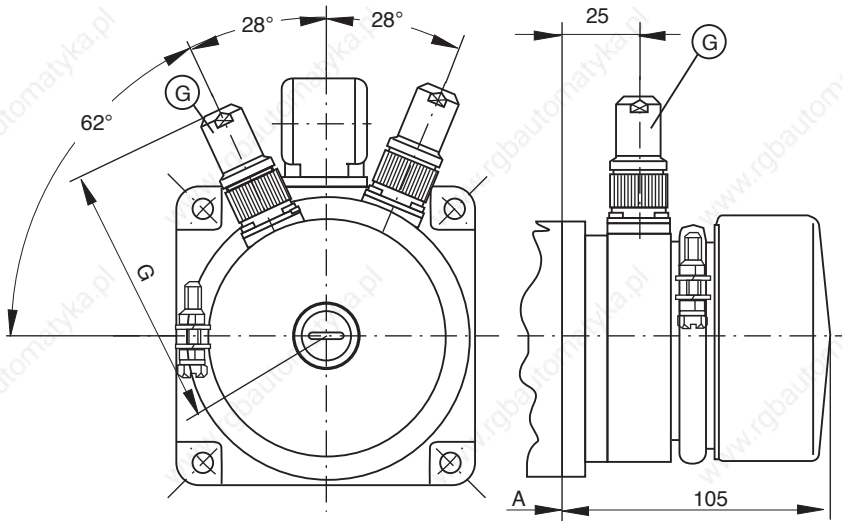

G Absolute encoder conn.
Must be ordered separately.

| Name | Conn. type | Dim. G |
|----------------|------------|--------|
| straight conn. | INS 326 | 104 |
| | INS 92 | |
| angle conn. | INS 322 | 102 |

3 Blocking brake

- without blocking brake
Dim. A retained
- Standard blocking brake: 3 Nm
Dim. A retained
- heavy-duty blocking brake: 6.5 Nm

Table for blocking brake with 6.5Nm holding torque

| Size | Dim. | A |
|-----------|------|-----|
| MAC 071 A | | 240 |
| MAC 071 B | | 280 |
| MAC 071 C | | 320 |

4 Output shaft

- plain shaft (recommended type)
- with keyway per DIN 6885 sh. 1, 8/68 edition
(Note! balanced with entire key.)

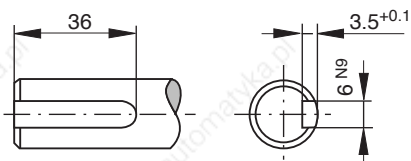

Matching key: DIN 6885-A 6 x 6 x 36
Must be ordered separately.

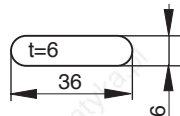

MB071-0/3

Fig 4.15: Dimensional data - MAC 071 - available options - (natural convection)

4.5. Dimensional Data - Radial Cooling

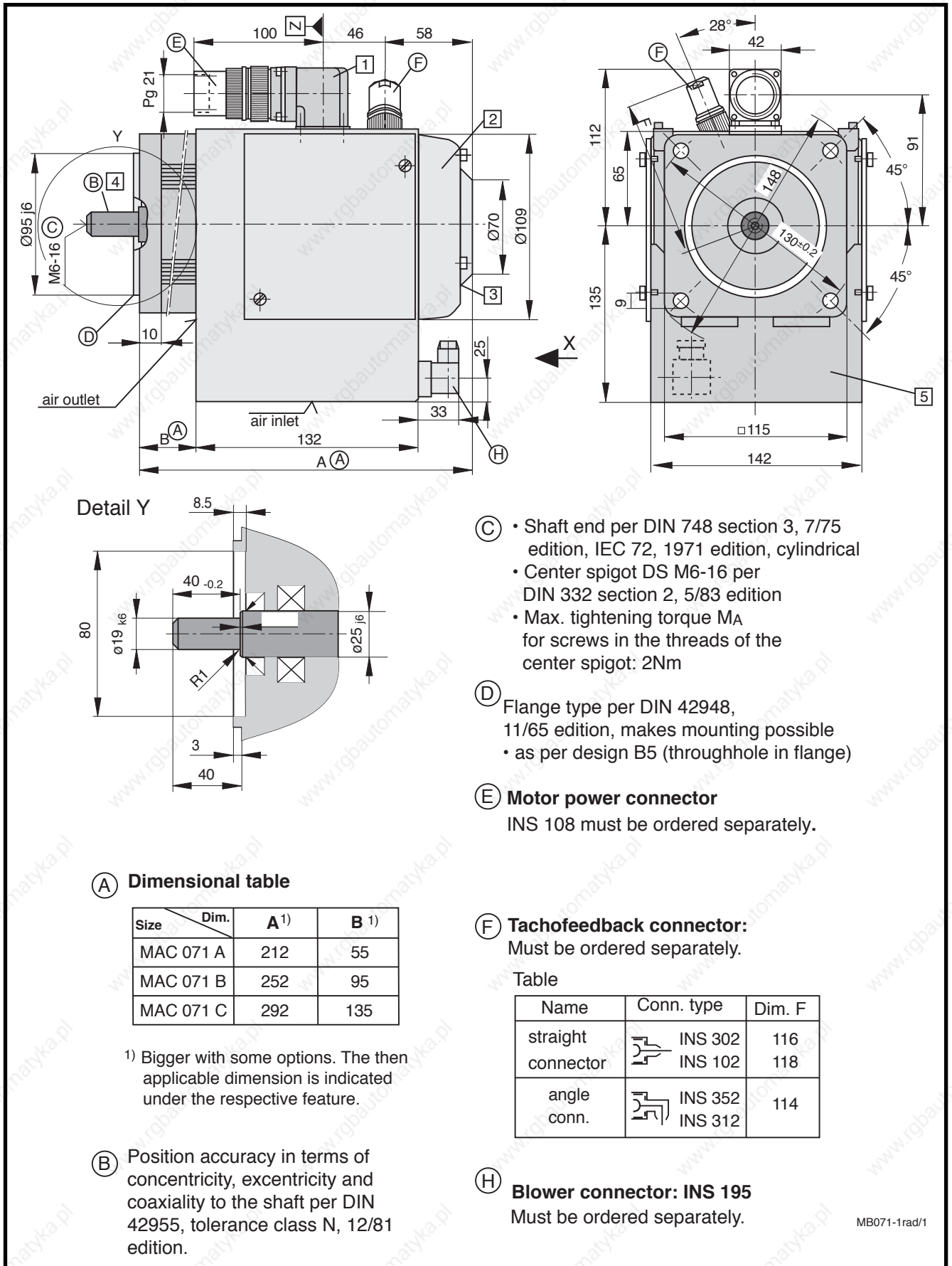

Fig 4.16: Dimensional data - MAC 071 (radial cooling)

MB071-1rad/1

Available options

1 Power connection

The output direction of the electrical power connector is selected at the time the order is placed. Possible output directions are:

- to side A
- to side B
- to the right
- to the left

The drawing depicts side A as output direction. The dimensions of any other direction are obtained by a virtual turning of the connector housing around the Z axis.

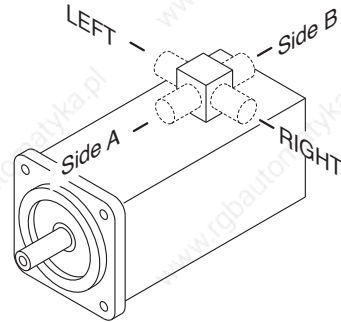

2 Motor version

- Tachofeedback and second shaft end

View X:

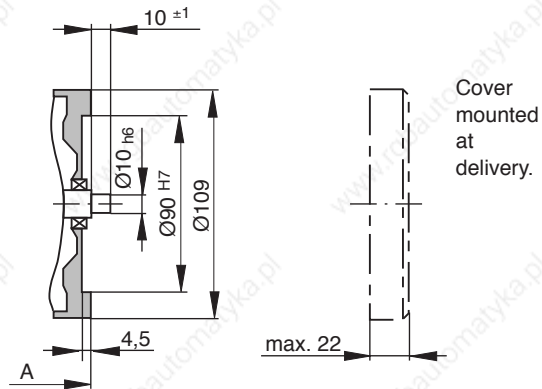
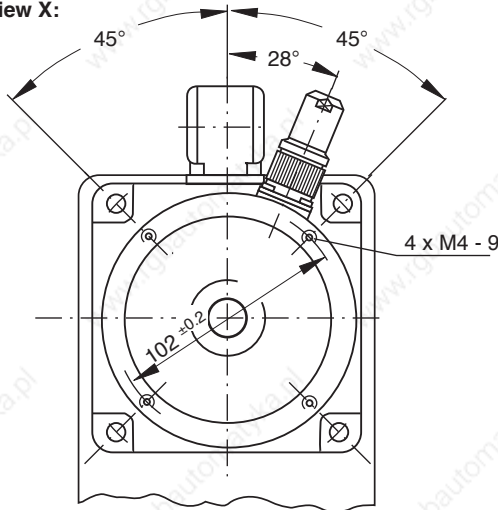

- Tachofeedback and mounted incremental encoder

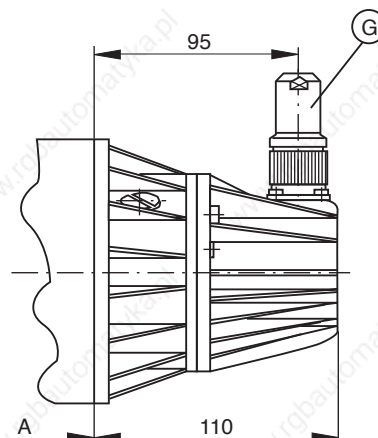
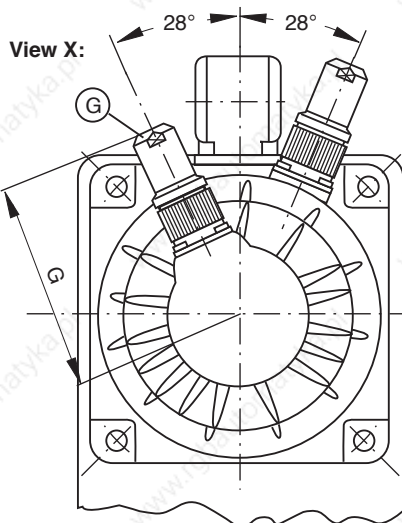

Incremental encoder connector

Must be ordered separately.

| Name | Conn. type | Dim. G |
|----------------|------------|--------|
| straight conn. | INS 301 | 88 |
| | INS 101 | 90 |
| angle conn. | INS 351 | 86 |
| | INS 311 | |

- Tachofeedback and mounted absolute encoder (see following page)

MB071-1rad/2

Fig 4.17: Dimensional data - MAC 071 - available options - (radial cooling)

Available options

- Tachofeedback and mounted absolute encoder

View X:

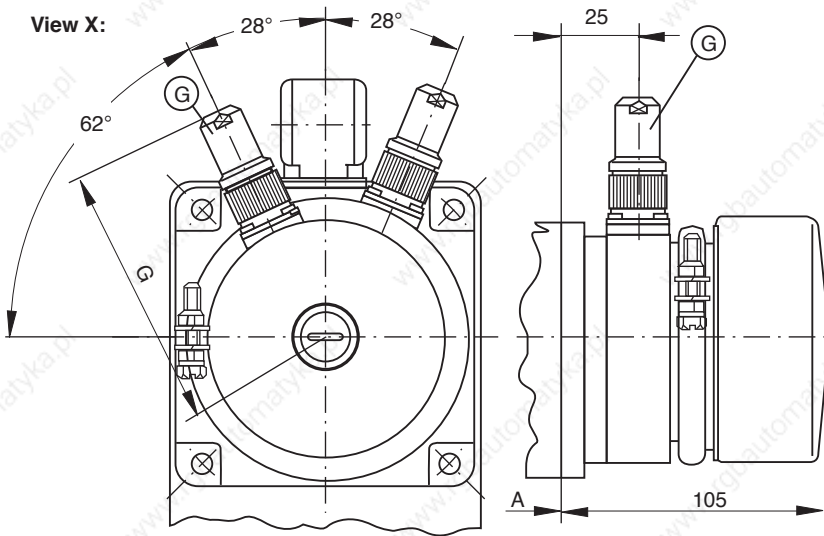

G Absolute encoder conn.
Must be ordered separately.

| Name | Conn. type | Dim. G |
|----------------|------------|--------|
| straight conn. | INS 326 | 104 |
| | INS 92 | |
| angle conn. | INS 322 | 102 |

3 Blocking brake

- without blocking brake
Dim. A and B retained
- Standard blocking brake: 3 Nm
Dim. A and B retained
- heavy-duty blocking brake: 6.5 Nm

Table for blocking brake with 6.5 Nm holding torque

| Size \ Dim. | A | B |
|-------------|-----|-----|
| MAC 071 A | 240 | 83 |
| MAC 071 B | 280 | 123 |
| MAC 071 C | 320 | 163 |

4 Output shaft

- plain shaft (recommended type)
- with keyway per DIN 6885 sh. 1, 8/68 edition
(Note! balanced with entire key.)

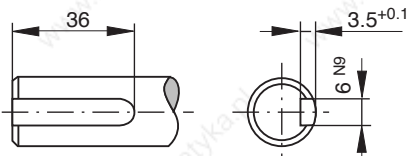

Matching key: DIN 6885-A 5 x 5 x 22
Must be ordered separately.

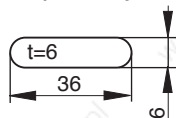

5 Blower arrangement

Looking towards motor shaft.

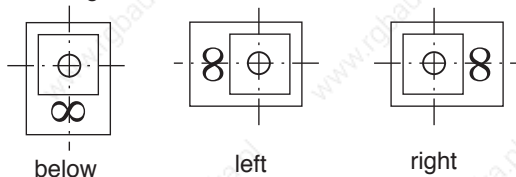

MB071-1rad/3

Fig 4.18: Dimensional data - MAC 071 - available options - (radial cooling)

4.6. Dimensional Data - Axial Cooling

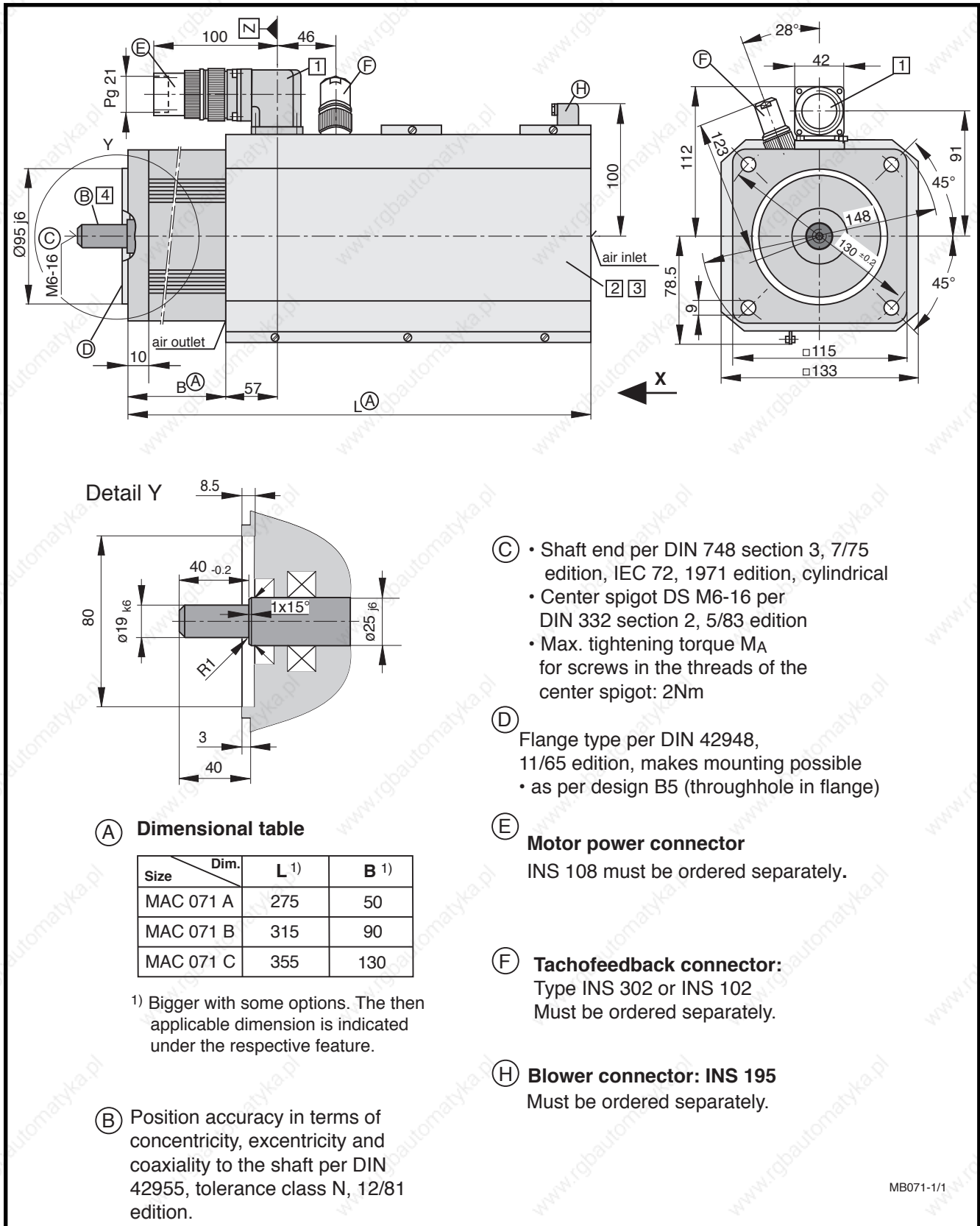

Fig 4.19: Dimensional data - MAC 071 (axial cooling)

Available options

1 Power connection

The output direction of the electrical power connector is selected at the time the order is placed. Possible output directions are:

- to side A
- to side B
- to the right
- to the left

The drawing depicts side A as output direction. The dimensions of any other direction are obtained by a virtual turning of the connector housing around the Z axis.

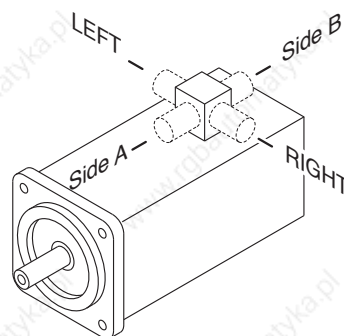

2 Motor version

- Tachofeedback and mounted incremental encoder

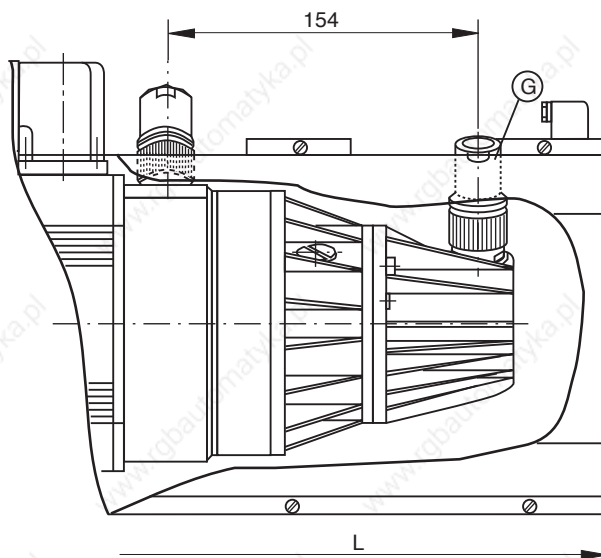
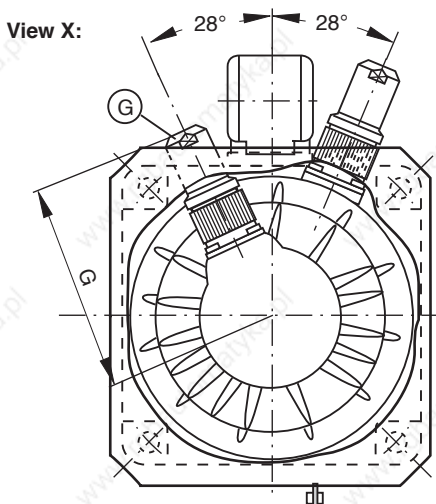

G Incremental encoder connector

Must be ordered separately.

| Name | Conn. type | Dim. G |
|----------|------------|--------|
| straight | INS 302 | 88 |
| conn. | INS 102 | 90 |

Table:

| Size | Dim. | L | B |
|-----------|------|-----|-----|
| MAC 071 A | | 395 | 78 |
| MAC 071 B | | 435 | 118 |
| MAC 071 C | | 475 | 158 |

- Tachofeedback and mounted absolute encoder (see following page)

MB071-1/2

Fig 4.20: Dimensional data - MAC 071 -available options - (axial cooling)

Available options

- Tachofeedback and mounted absolute encoder

View X:

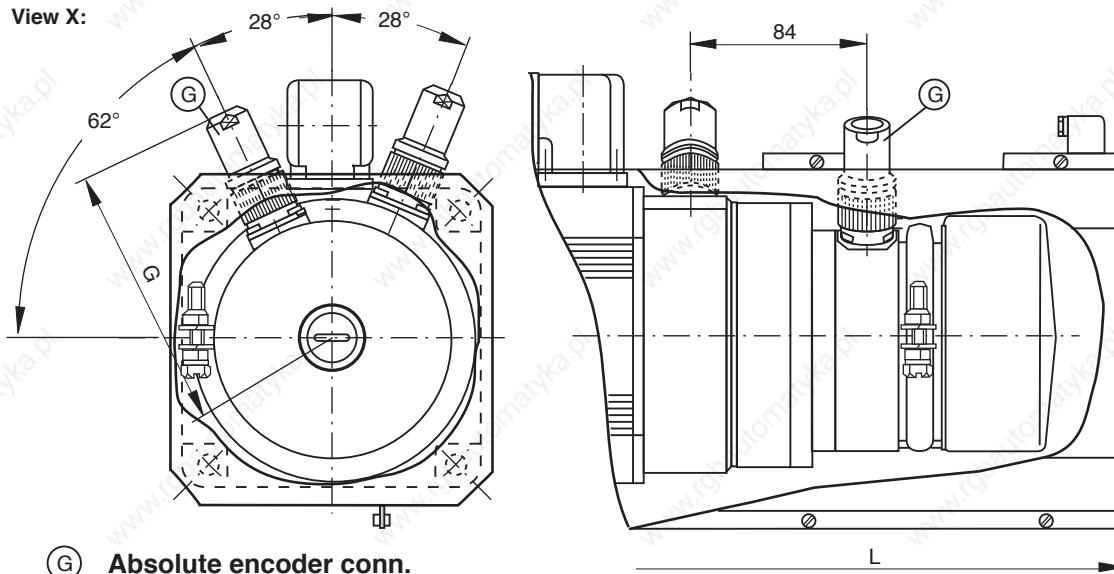

G Absolute encoder conn.
Must be ordered separately.

| Name | Conn. type | Dim. G |
|----------------|-------------------|------------|
| straight conn. | INS 326 INS 92 | 104 106 |

Table

| Size | Dim. | L | B |
|-----------|------|-----|-----|
| MAC 071 A | | 395 | 78 |
| MAC 071 B | | 435 | 118 |
| MAC 071 C | | 475 | 158 |

3 Blocking brake

- without blocking brake
Dim. L and B retained
- Standard blocking brake: 3 Nm
Dim. L and B retained
- heavy-duty blocking brake: 6.5 Nm

Table for blocking brake
with 6.5Nm holding torque

| Size | Dim. | Vers. 2 | | Vers. 4 | |
|-----------|------|---------|-----|---------|-----|
| | | L | B | L | B |
| MAC 071 A | | 303 | 78 | 423 | 106 |
| MAC 071 B | | 343 | 118 | 463 | 146 |
| MAC 071 C | | 383 | 158 | 503 | 186 |

Vers. 2 =
Motor with tachofeedback

Vers. 4 =
Motor with tachofeedback and
mounted encoder

4 Output shaft

- plain shaft (recommended type)
- with keyway per DIN 6885 sh. 1, 8/68 edition
(Note! balanced with entire key.)

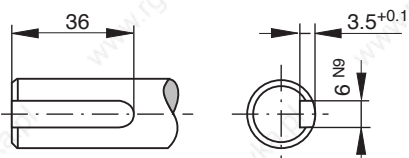

Matching key: DIN 6885-A 5 x 5 x 22
Must be ordered separately.

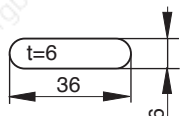

MB071-1/3

Fig 4.21: Dimensional data - MAC 071 - available options - (axial cooling)

4.7. Available Options

| Type code fields | | Example: | MAC 071 A-0-ES-4 - C/095-A-0/WI 520LV/S000 | | | | | | | |
|--|--|----------|--|-----------------|---|----|---|---|----|-----|
| 1. Motor for analogue drives | | MAC | | | | | | | | |
| 2. Motor size | | 071 | | | | | | | | |
| 3. Motor length | | A, B, C | | | | | | | | |
| 4. Type of cooling: | | | | | | | | | | |
| natural convection | | | | | | | | | | |
| surface cooling | | | | | | | | | | |
| axial | | | | | | | | | | |
| radial | | | | | | | | | | |
| blower right | | | | | | | | | | |
| blower below | | | | | | | | | | |
| blower left | | | | | | | | | | |
| AC 230 V | | | | | | | | | | |
| AC 115 V | | | | | | | | | | |
| AC 230 V | | | | | | | | | | |
| AC 115 V | | | | | | | | | | |
| AC 230 V | | | | | | | | | | |
| AC 115 V | | | | | | | | | | |
| 0 | | | 1 ¹⁾ | 2 ¹⁾ | 6 | A | 7 | B | 8 | C |
| 5. Type of windings | | | | | | | | | | |
| Nominal rpm | | | | | | | | | | |
| Motor length | | | | | | | | | | |
| A | | | | | | | | | | |
| B | | | | | | | | | | |
| C | | | | | | | | | | |
| 2000 min ⁻¹ | | | HS | | | FS | | | US | |
| 3000 min ⁻¹ | | | OS | | | TS | | | NS | |
| 4000 min ⁻¹ | | | ES | | | PS | | | JS | |
| 6000 min ⁻¹ | | | VS | | | KS | | | GS | |
| 6. Motor feedback | | | | | | | | | | |
| Motor type | | | | | | | | | | |
| with tachofeedback | | | | | | | | | | 2 |
| with tachofeedback and second shaft end | | | | | | | | | | 3 |
| with tachofeedback and mounted incremental or absolute encoder | | | | | | | | | | 4 |
| Tacho voltage | | | | | | | | | | |
| set to nominal motor speed | | | | | | | | | | - |
| (nominal rpm > 3000 min ⁻¹) | | | | | | | | | | |
| : 1.5 V/1000 min ⁻¹) | | | | | | | | | | |
| (nominal rpm ≤ 3000 min ⁻¹) | | | | | | | | | | |
| : 3 V/1000 min ⁻¹) | | | | | | | | | | |
| 1.5 V/1000 min ⁻¹) | | | | | | | | | | H |
| Tacho type | | | | | | | | | | |
| Standard | | | | | | | | | | C |
| increased smooth run quality | | | | | | | | | | F |
| 7. Centering diameter | | | | | | | | | | |
| for design B05 and B14 | | | | | | | | | | 095 |
| 8. Power connection | | | | | | | | | | |
| connector to side A | | | | | | | | | | A |
| connector to side B | | | | | | | | | | B |
| connector to right (looking onto output shaft) | | | | | | | | | | R |
| connector to left (looking onto output shaft) | | | | | | | | | | L |
| 9. Blocking brake | | | | | | | | | | |
| without blocking brake | | | | | | | | | | 0 |
| with standard blocking brake (3 Nm) | | | | | | | | | | 1 |
| with heavy-duty blocking brake (6.5 Nm) | | | | | | | | | | 2 |
| 10. Type ²⁾ | | | | | | | | | | |
| Incremental encoder with standard mounting | | | | | | | | | | WI |
| Incremental encoder with shock-damped mounting | | | | | | | | | | DI |
| Absolute encoder | | | | | | | | | | AM |
| 11. Encoder code ²⁾ | | | | | | | | | | |
| For available types, see section 2.4 "Motor feedback" | | | | | | | | | | |
| 12. Special types | | | | | | | | | | |
| Fixed and documented by INDRAMAT with special number (see Drawing no.: 106-0105-4301-XX) | | | | | | | | | | |
| Does not apply to standard motors. | | | | | | | | | | |

Fig 4.22: Type codes MAC 071

TLMAC071

4.8. Special Options

| | |
|-----------------------------------|------|
| Specification of Option | S001 |
| with keyway per DIN 6885, sheet 1 | X |

Fig 4.23: Special options with a MAC 071

Empty page

5. MAC 090

5.1. Technical Data

| Designation | Symbol | Unit | Motor type MAC ... | | | |
|---|-------------------|-------------------|---------------------------|---------------------------|---------------------------|---------------------------|
| | | | 090 A - - - Z • | 090 B - - - P • | 090 C - - - K • | 090 C - - - ED |
| Nominal motor speed ¹⁾ | n | min ⁻¹ | 2000 | 2000 | 2000 | 5000 |
| Continuous torque at standstill ²⁾ | M _{dN} | Nm | 3.7 (5.0) ⁵⁾ | 7.2 (10.5) ⁵⁾ | 10.4 (16.0) ⁵⁾ | 10.0 (16.0) ⁵⁾ |
| Continuous current at standstill | I _{dN} | A | 8.1(10.9) ⁵⁾ | 11.9 (17.4) ⁵⁾ | 17.0 (26.1) ⁵⁾ | 35.0 (52.0) ⁵⁾ |
| Rotor moment of inertia ³⁾ | J _M | kgm ² | 20 x 10 ⁻⁴ | 36 x 10 ⁻⁴ | 53 x 10 ⁻⁴ | 53 x 10 ⁻⁴ |
| Torque constant at 20 °C | K _m | Nm/A | 0.51 | 0.67 | 0.68 | 0.31 |
| Windings resistance at 20 °C | R _A | Ohm | 1.85 | 0.97 | 0.60 | 0.12 |
| Windings inductance | L _A | mH | 1.9 | 5.1 | 3.6 | 0.8 |
| Maximum peak of pulse current | I _{peak} | A | 53 | 86 | 125 | 270 |
| Thermal time constant | T _{th} | min | 45 (30) ⁵⁾ | 60 (45) ⁵⁾ | 60 (45) ⁵⁾ | 60 (45) ⁵⁾ |
| Mass ⁴⁾ | m _M | kg | 12.5 | 18 | 23 | 23 |
| | | | 090 A - - - R • | 090 B - - - N • | 090 B - - - J • | 090 C - - - G • |
| Nominal motor speed ¹⁾ | n | min ⁻¹ | 3000 | 3000 | 3000 | 3000 |
| Continuous torque at standstill ²⁾ | M _{dN} | Nm | 3.5 (5.0) ⁵⁾ | 6.7 (10.5) ⁵⁾ | 6.7 (10.5) ⁵⁾ | 9.6 (16.0) ⁵⁾ |
| Continuous current at standstill | I _{dN} | A | 11.4 (16.3) ⁵⁾ | 13.0 (20.0) ⁵⁾ | 18.2 (28.5) ⁵⁾ | 24.8 (41.3) ⁵⁾ |
| Rotor moment of inertia ³⁾ | J _M | kgm ² | 20 x 10 ⁻⁴ | 36 x 10 ⁻⁴ | 36 x 10 ⁻⁴ | 53 x 10 ⁻⁴ |
| Torque constant at 20 °C | K _m | Nm/A | 0.34 | 0.58 | 0.41 | 0.43 |
| Windings resistance at 20 °C | R _A | Ohm | 0.56 | 0.75 | 0.38 | 0.24 |
| Windings inductance | L _A | mH | 3.2 | 3.9 | 2.0 | 1.5 |
| Maximum peak of pulse current | I _{peak} | A | 76 | 98 | 137 | 196 |
| Thermal time constant | T _{th} | min | 45 (30) ⁵⁾ | 60 (45) ⁵⁾ | 60 (45) ⁵⁾ | 60 (45) ⁵⁾ |
| Mass ⁴⁾ | m _M | kg | 12.5 | 18 | 18 | 23 |

¹⁾ The usable motor speed is determined by the drive used.
 Only those usable speeds n_{max} found in the selection lists of the motor-drive combinations are binding.
²⁾ With 60K overtemperature at the motor housing.
 Continuous torque can be limited by the drive. See selection data.
³⁾ With tacho-generator, without holding brake
⁴⁾ With tacho-generator, without holding brake, without blower.
⁵⁾ Parenthetical values apply to versions with surface cooling.

Fig 5.1: Type-dependent motor data

| Designation | Symbol | Unit | Data | | |
|--|-----------------|---------------------|--------------------------------|--------|----------------------|
| Permissible ambient temperature | T _{um} | °C | 0 ... + 45 | | |
| Permissible storage and transport temperature | T _L | °C | -20 ... +80 | | |
| Maximum installation elevation | | m | 1000 m. above sea level | | |
| Protection category | | | IP 65 | | |
| Insulation classification | | | F | | |
| Housing coat | | | Black prime coat (RAL 9005) | | |
| Voltage constant of the tachogenerator ¹⁾ | C _w | Vs/rad | 0.0143 | 0.0286 | 0.0572 |
| | | V/min ⁻¹ | 1.5/1000 | 3/1000 | 6/1000 ²⁾ |

¹⁾ Tachovoltage can be selected application-related.
²⁾ If the 6 V/1000 min⁻¹ tachometer is used, then the maximum usable speed is limited to 1600 min⁻¹.

Fig 5.2: General data MAC 090

| Designation | Symbol | Unit | Data holding brake | |
|---------------------|--------|------------------|-----------------------|-------------------------------|
| | | | Standard | heavy-duty |
| Principle of action | | | | electrically-actuated release |
| Holding torque | M_H | Nm | 6.5 | 14 |
| Nominal voltage | U_N | V | | DC 24 ± 10% |
| Nominal current | I_N | A | 0.7 | 0.7 |
| Moment of inertia | J_B | kgm ² | 1.06×10^{-4} | 3.6×10^{-4} |
| Release delay | t_L | ms | 60 | 70 |
| Clamping delay | t_K | ms | 20 | 30 |
| Mass | m_B | kg | 0.5 | 0.5 |

Fig 5.3: Technical data - holding brake

| Designation | Symbol | Unit | Data surface cooling | |
|----------------------------------|--------|------|-----------------------------|-----------------------------|
| | | | Axial cooling | Radial cooling |
| Power consumption | S_N | VA | 40/42 | 40/42 |
| Nominal voltage | U_N | V | AC 230 or 115 ¹⁾ | AC 230 or 115 ¹⁾ |
| Frequency | f | Hz | 50/60 | 50/60 |
| Mass | m_L | kg | approx. 3.3 ²⁾ | approx. 3.2 ²⁾ |
| Protection category blower unit | | | IP 24 | IP 24 |
| Protection category blower motor | | | IP 44 | IP 44 |

¹⁾ 115 V special design
²⁾ Blower shroud for motor with tacho feedback.

Fig 5.4: Technical data - surface cooling

5.2. Torque-Speed Characteristics

MAC 090 A - - - Z •
2000 min⁻¹

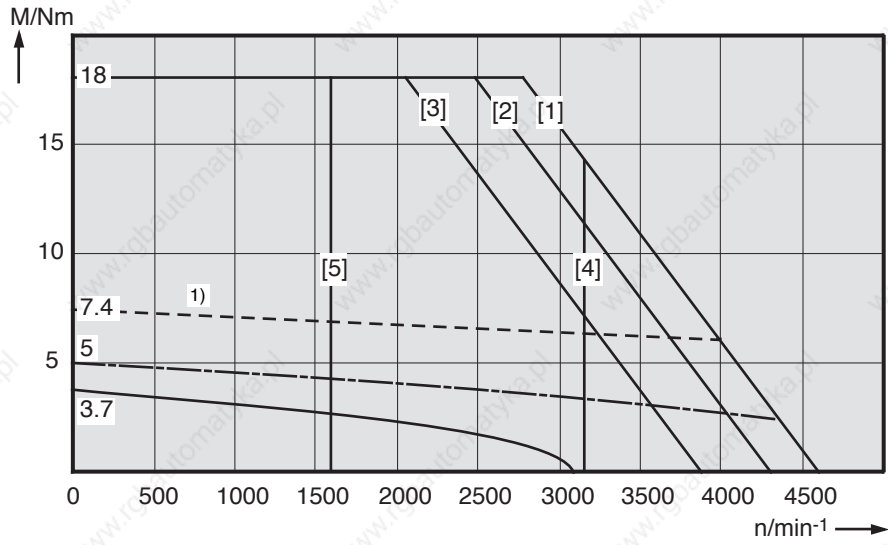

MAC 090 A - - - R •
3000 min⁻¹

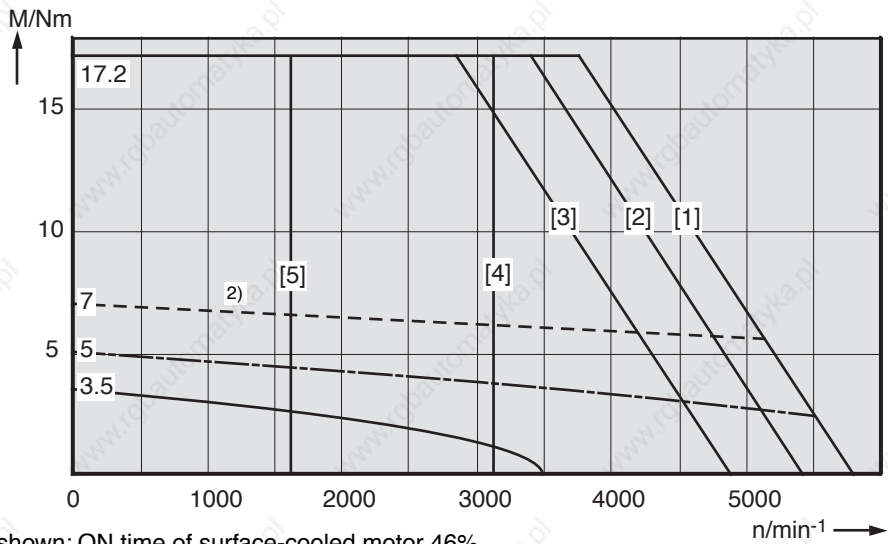

1) shown: ON time of surface-cooled motor 46%
2) shown: ON time of surface-cooled motor 51%

Fig 5.5: Torque-speed characteristics MAC 090

MAC 090 B - - - P •
2000 min⁻¹

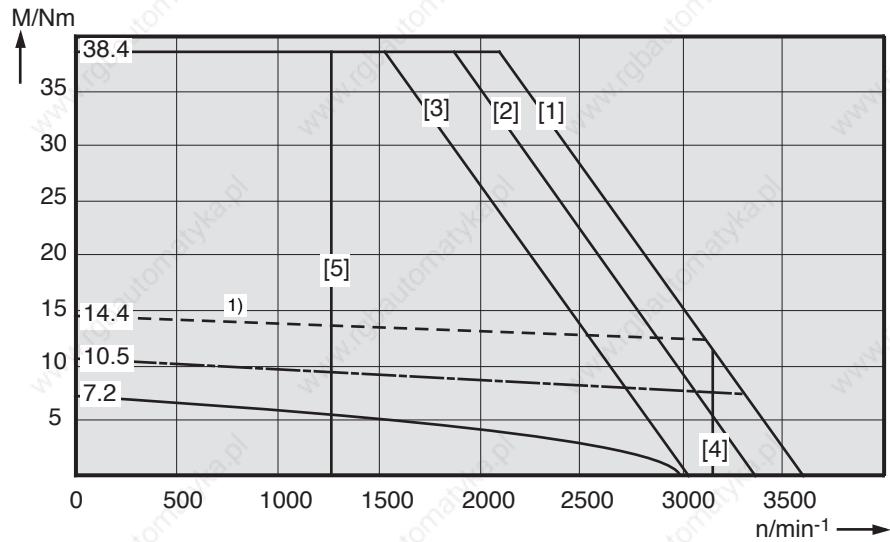

MAC 090 B - - - N •
3000 min⁻¹

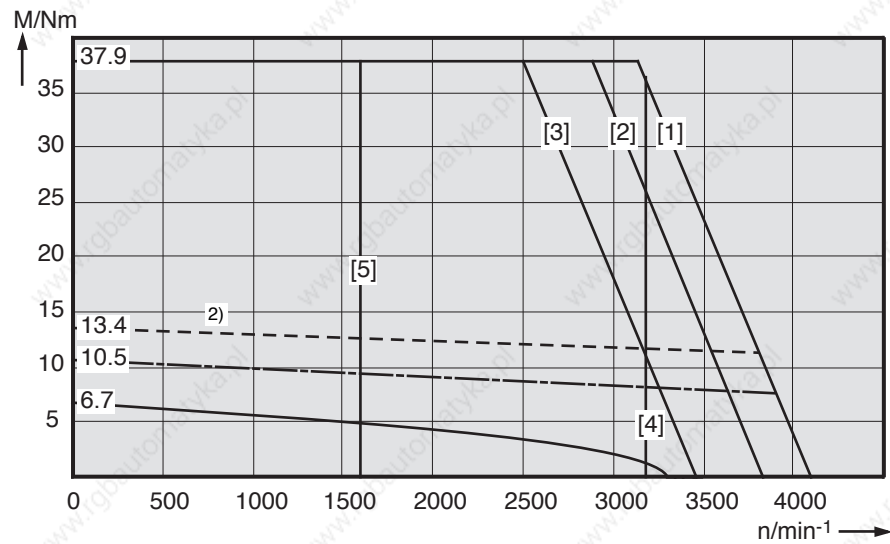

MAC 090 B - - - J •
3000 min⁻¹

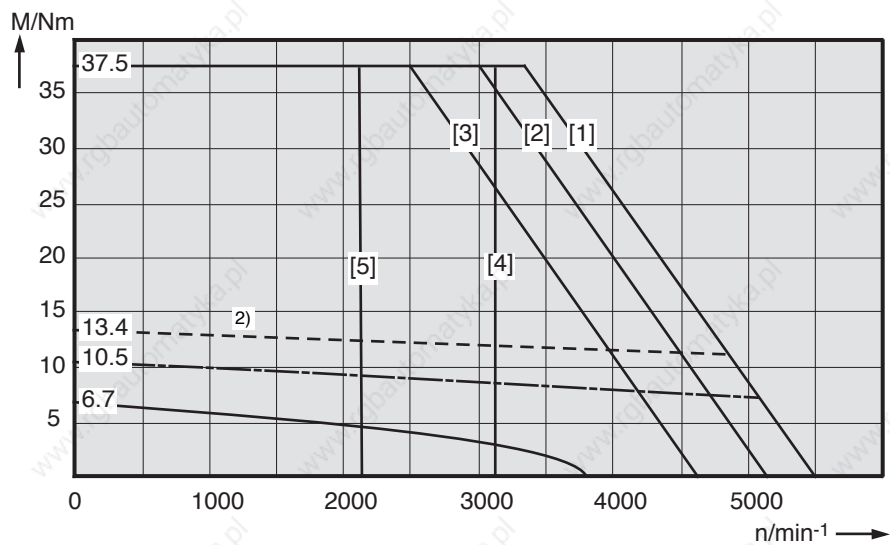

1) shown: ON time of surface-cooled motor 53%
2) shown: ON time of surface-cooled motor 61%

Fig 5.6: Torque-speed characteristics MAC 090

MAC 090 C - - - K •
2000 min⁻¹

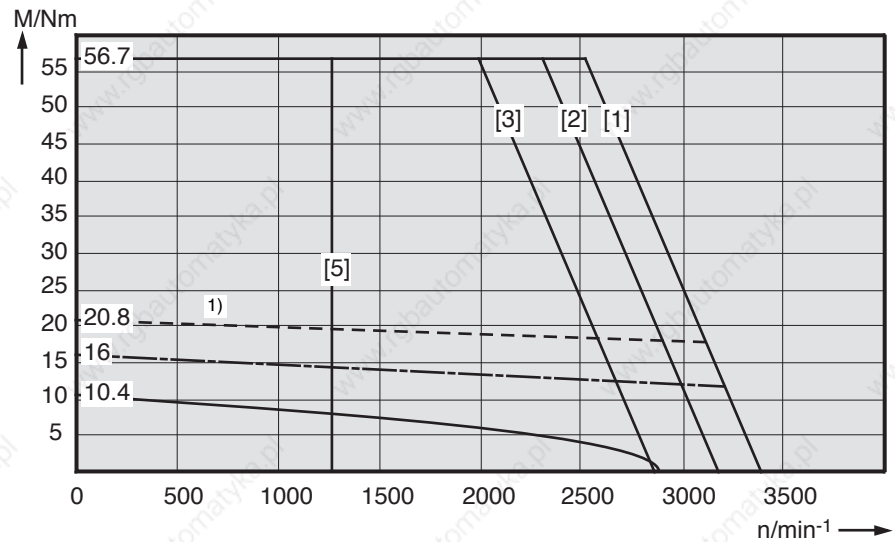

MAC 090 C - - - G •
3000 min⁻¹

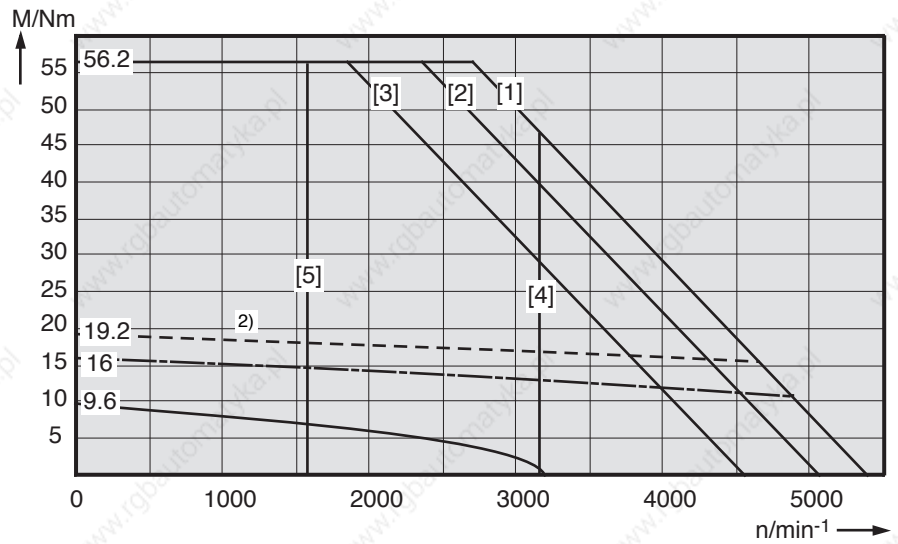

MAC 090 C - - - E •
5000 min⁻¹

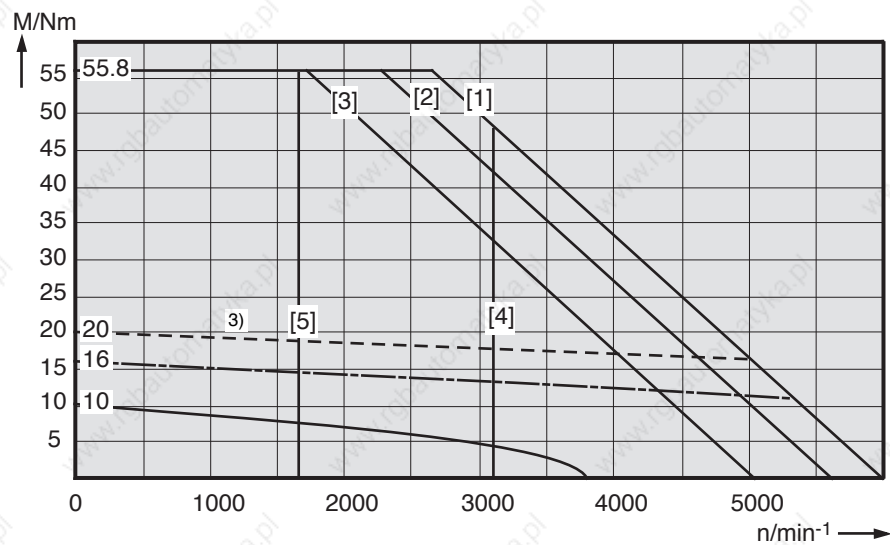

- 1) shown: ON time of surface-cooled motor 59%
- 2) shown: ON time of surface-cooled motor 69%
- 3) shown: ON time of surface-cooled motor 64%

Fig 5.7: Torque-speed characteristics MAC 090

5.3. Shaft load capacity

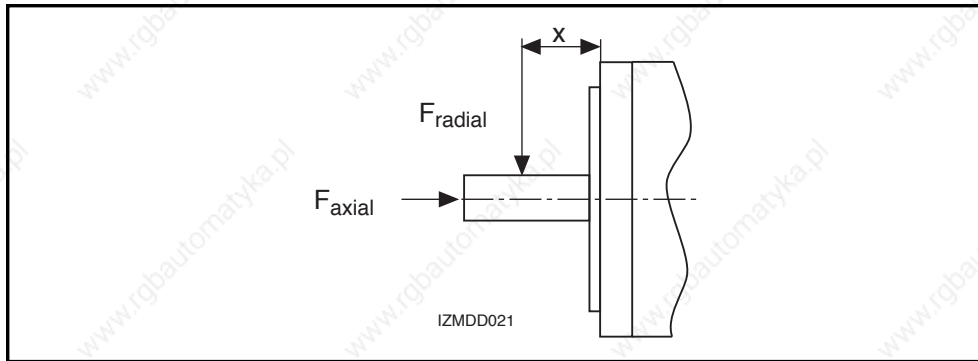

Fig 5.8: Shaft load

Permissible radial force
 F_{radial}

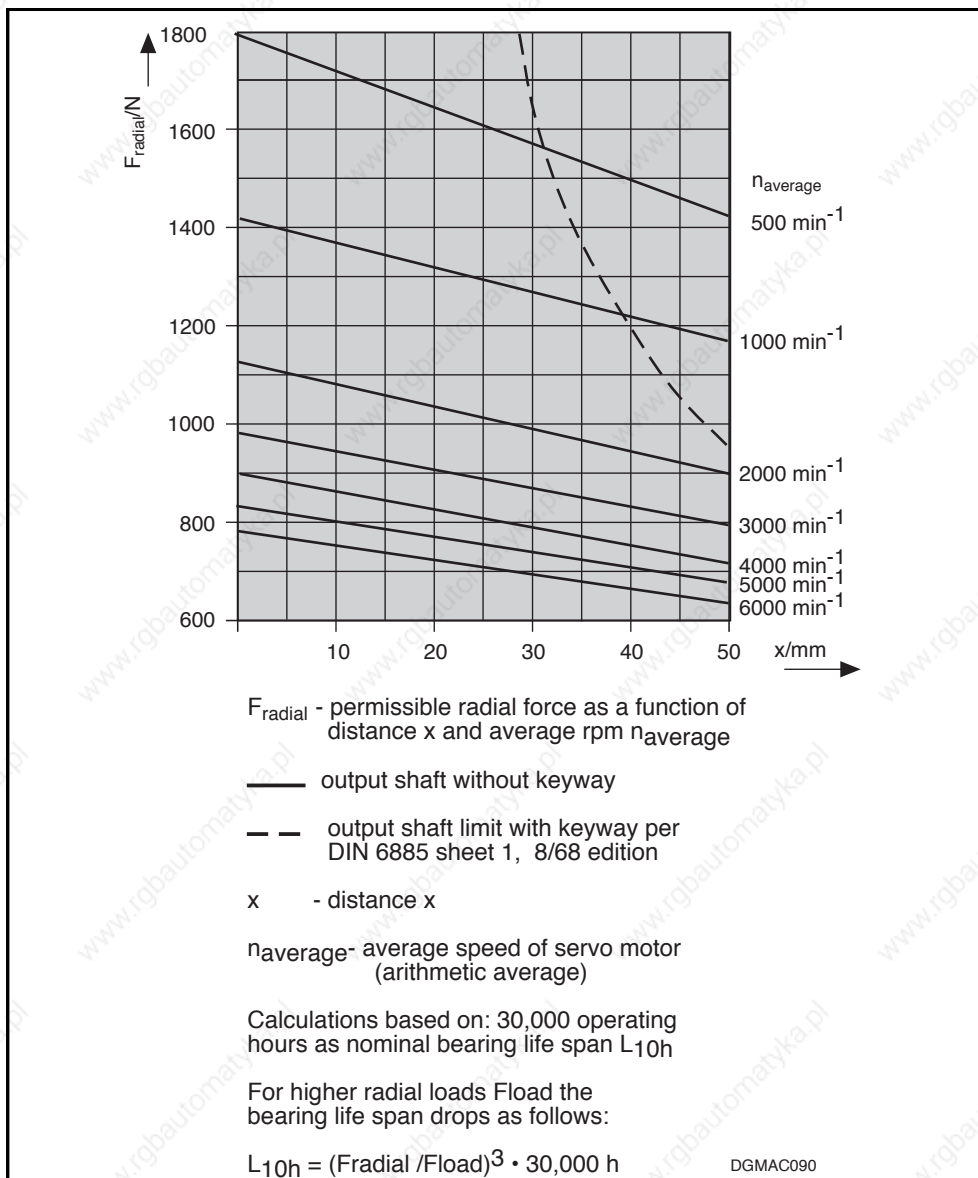

Fig 5.9: Permissible radial force

Permissible axial force
 F_{axial}

$$F_{axial} = 0.34 \cdot F_{radial}$$

F_{axial} - Permissible axial force

F_{radial} - Permissible radial force

5.4. Dimensional data - natural convection

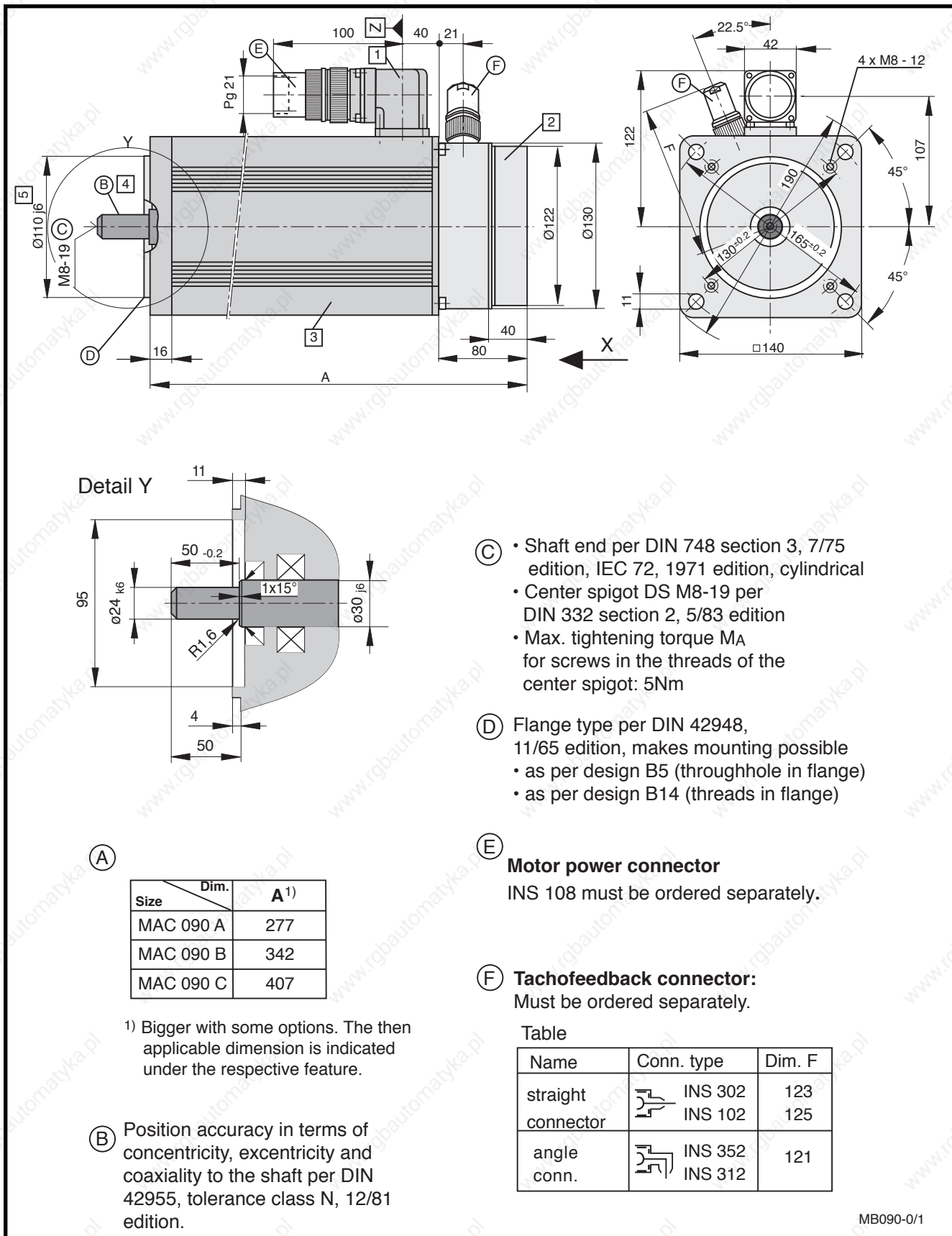

Fig 5.10: Dimensional data - MAC 090 (natural convection)

Available options

1 Power connection

The output direction of the electrical power connector is selected at the time the order is placed. Possible output directions are:

- to side A
- to side B
- to the right
- to the left

The drawing depicts side A as output direction. The dimensions of any other direction are obtained by a virtual turning of the connector housing around the Z axis.

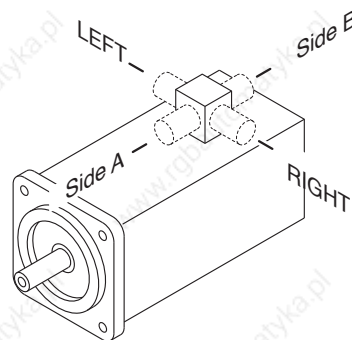

2 Motor version

- Tachofeedback and second shaft end

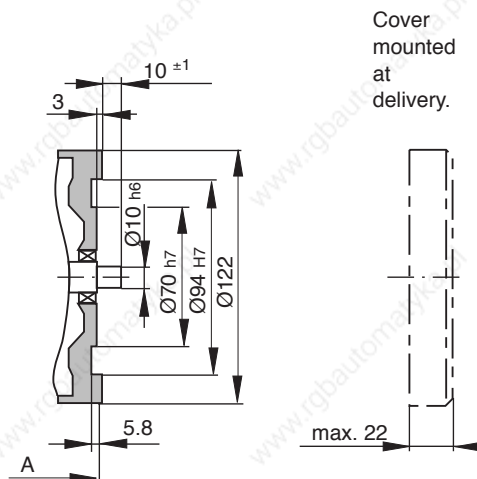
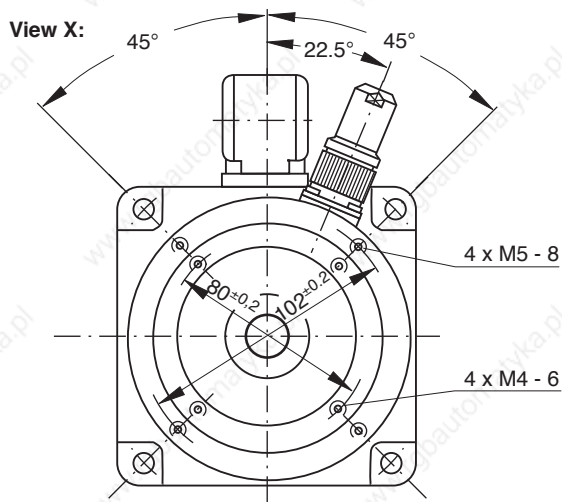

- Tachofeedback and mounted incremental encoder

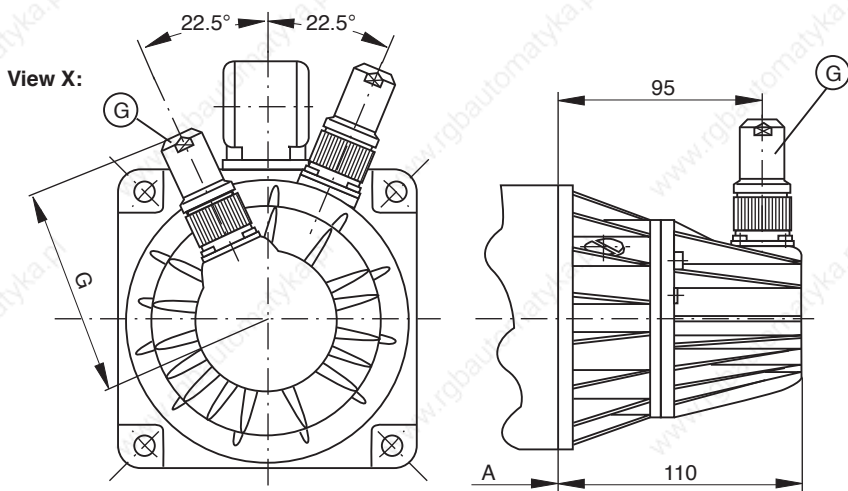

G Incremental encoder connector

Must be ordered separately.

| Name | Conn. type | Dim. G |
|----------------|--------------------|--------|
| straight conn. | INS 301 | 88 |
| | INS 101 | 90 |
| angle conn. | INS 351 INS 311 | 86 |

- Tachofeedback and mounted absolute encoder (see following page)

MB090-0/2

Fig 5.11: Dimensional data - MAC 090 - available options - (natural convection)

Available options

- Tachofeedback and mounted absolute encoder

View X:

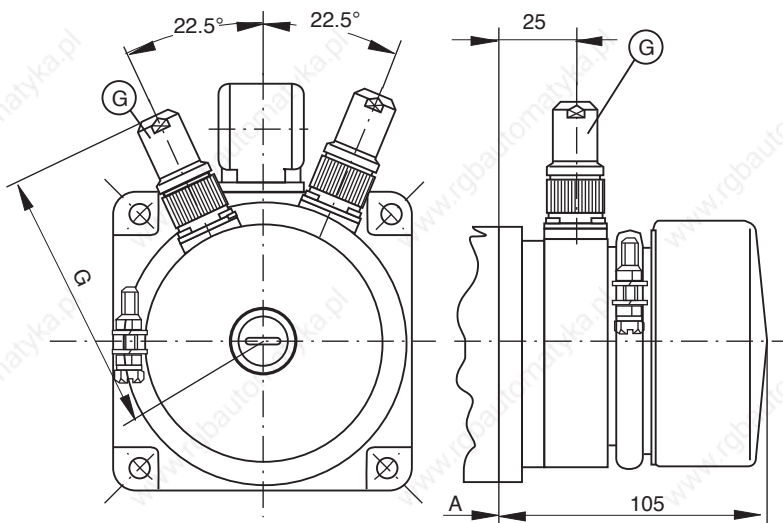

G Absolute encoder conn.
Must be ordered separately.

| Name | Conn. type | Dim. G |
|----------------|------------|--------|
| straight conn. | INS 326 | 104 |
| | INS 92 | 106 |
| angle conn. | INS 322 | 102 |

3 Blocking brake

- without blocking brake
Dim. A retained
- Standard blocking brake: 6.5 Nm
Dim. A retained
- heavy-duty blocking brake: 14.0 Nm

Table for 14 Nm blocking brake

| Size | Dim. | A |
|-----------|------|-----|
| MAC 090 A | | 327 |
| MAC 090 B | | 392 |
| MAC 090 C | | 457 |

4 Output shaft

- plain shaft (recommended type)
- with keyway per DIN 6885 sh. 1, 8/68 edition
(Note! balanced with entire key.)

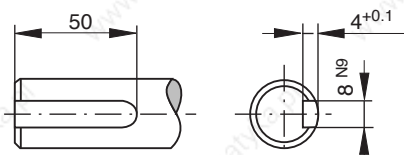

Matching key: DIN 6885-A 5 x 5 x 22
Must be ordered separately.

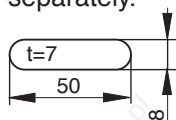

5 Special centering diameter

- Ø130 j6

MB090-0/3

Fig 5.12: Dimensional data - MAC 090 - available options - (natural convection)

5.5. Dimensional data - radial cooling

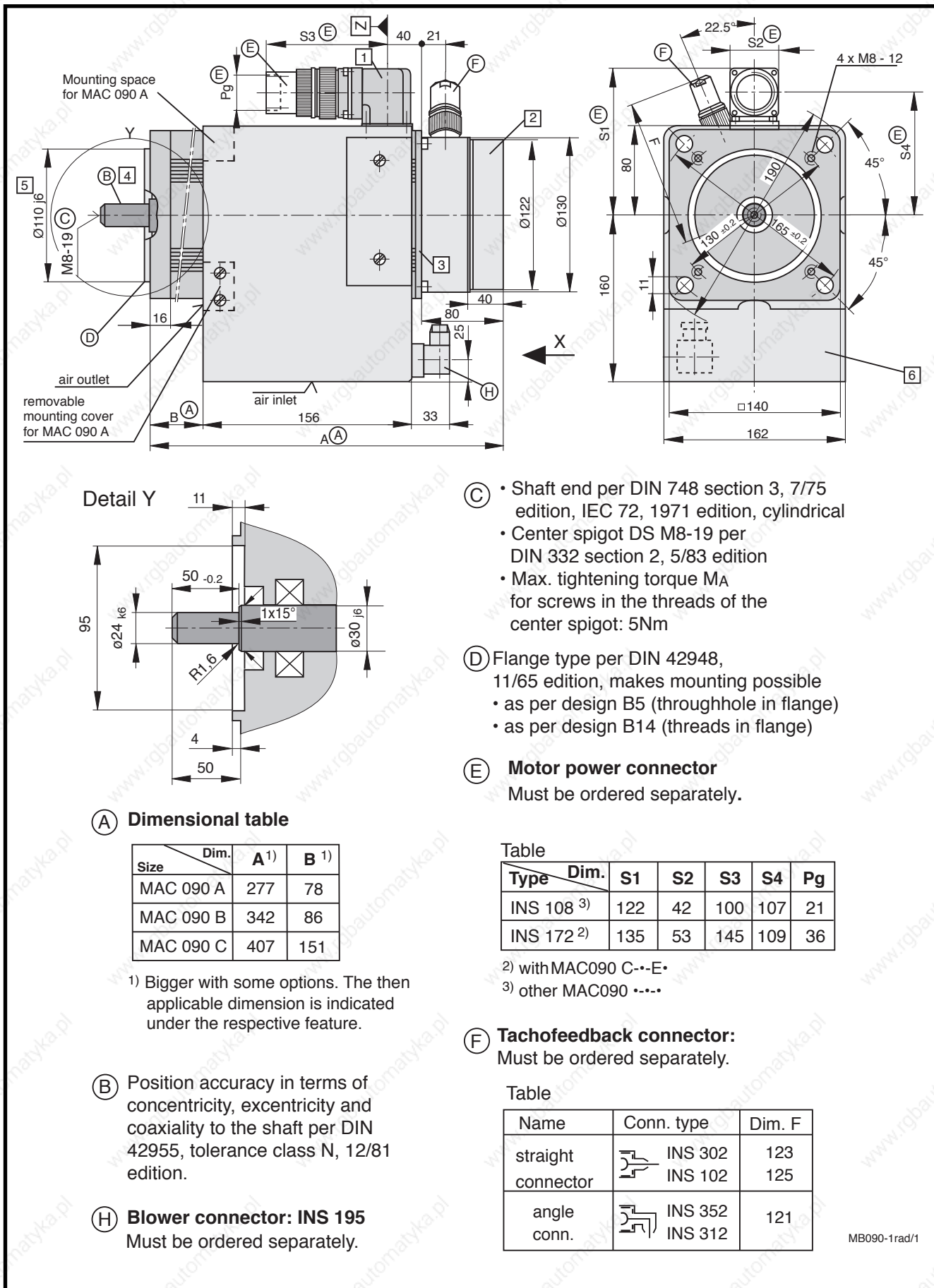

Fig 5.13: Dimensional data - MAC 090 (radial cooling)

Available options

1 Power connection

The output direction of the electrical power connector is selected at the time the order is placed. Possible output directions are:

- to side A
- to side B
- to the right
- to the left

The drawing depicts side A as output direction. The dimensions of any other direction are obtained by a virtual turning of the connector housing around the Z axis.

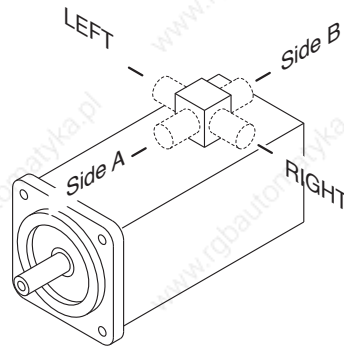

2 Motor version

- Tachofeedback and second shaft end

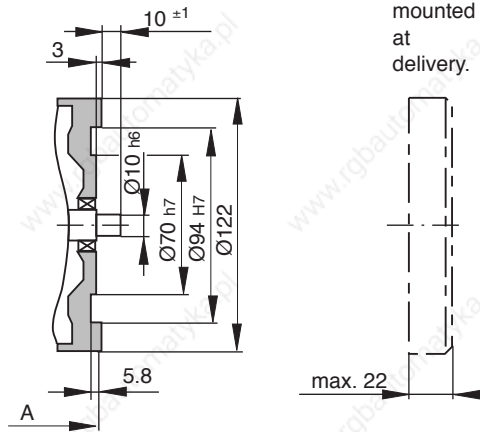
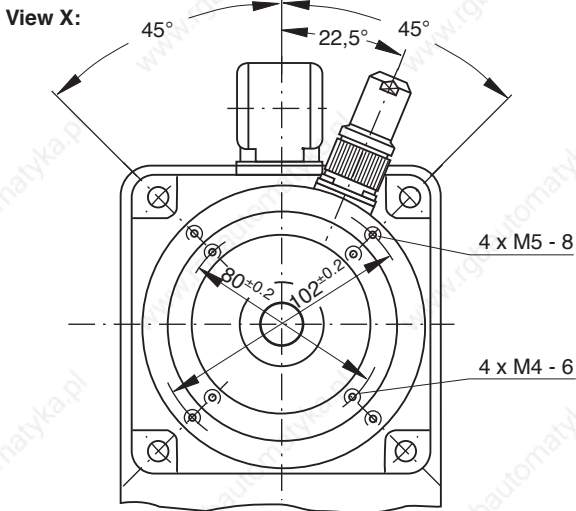

- Tachofeedback and mounted incremental encoder

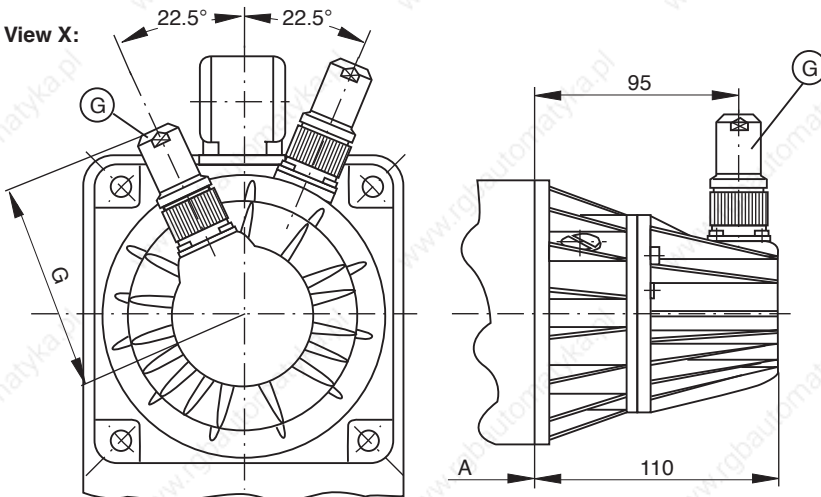

G Incremental encoder connector

Must be ordered separately.

| Name | Conn. type | Dim. G |
|----------------|--------------------|--------|
| straight conn. | INS 301 | 88 |
| | INS 101 | 90 |
| angle conn. | INS 351 INS 311 | 86 |

- Tachofeedback and mounted absolute encoder (see following page)

MB090-1rad/2

Fig 5.14: Dimensional data - MAC 090 - available options - (radial cooling)

Available options

- Tachofeedback and mounted absolute encoder

View X:

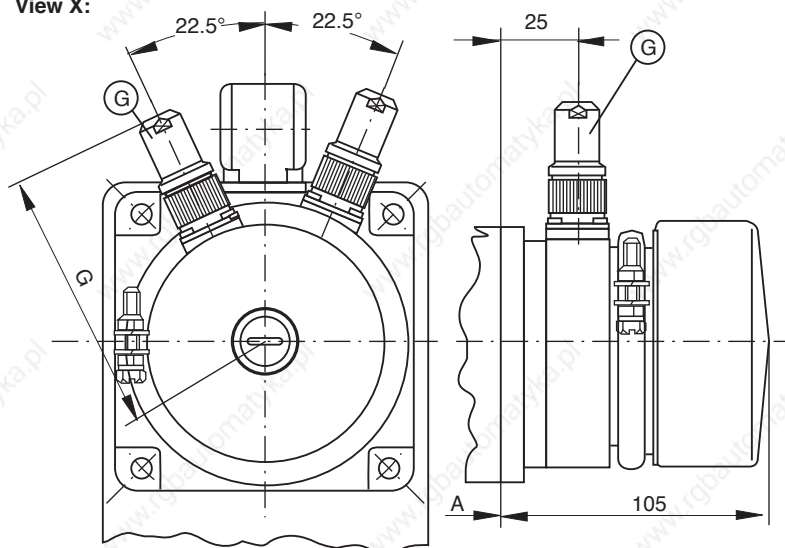

Ⓒ **Absolute encoder conn.**
Must be ordered separately.

| Name | Conn. type | Dim. G |
|----------------|------------|--------|
| straight conn. | INS 326 | 104 |
| | INS 92 | |
| angle conn. | INS 322 | 102 |

3 Blocking brake

- without blocking brake
Dim. A and B retained
- Standard blocking brake: 6.5 Nm
Dim. A and B retained
- heavy-duty blocking brake: 14.0 Nm

Table for 14 Nm blocking brake

| Size | Dim. | A | B |
|-----------|------|-----|-----|
| MAC 090 A | | 327 | 128 |
| MAC 090 B | | 392 | 136 |
| MAC 090 C | | 457 | 185 |

4 Output shaft

- plain shaft (recommended type)
- with keyway per DIN 6885 sh. 1, 8/68 edition
(Note! balanced with entire key.)

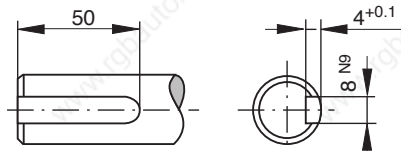

Matching key: DIN 6885-A 5 x 5 x 22
Must be ordered separately.

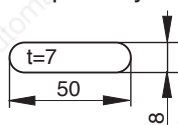

5 Special centering diameter

- $\varnothing 130 j6$

6 Blower arrangement

Looking towards motor shaft.

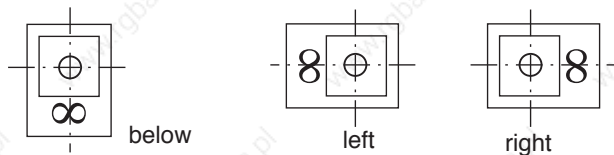

MB090-1rad/3

Fig 5.15: Dimensional data - MAC 090 - available options - (radial cooling)

5.6. Dimensional data - axial cooling

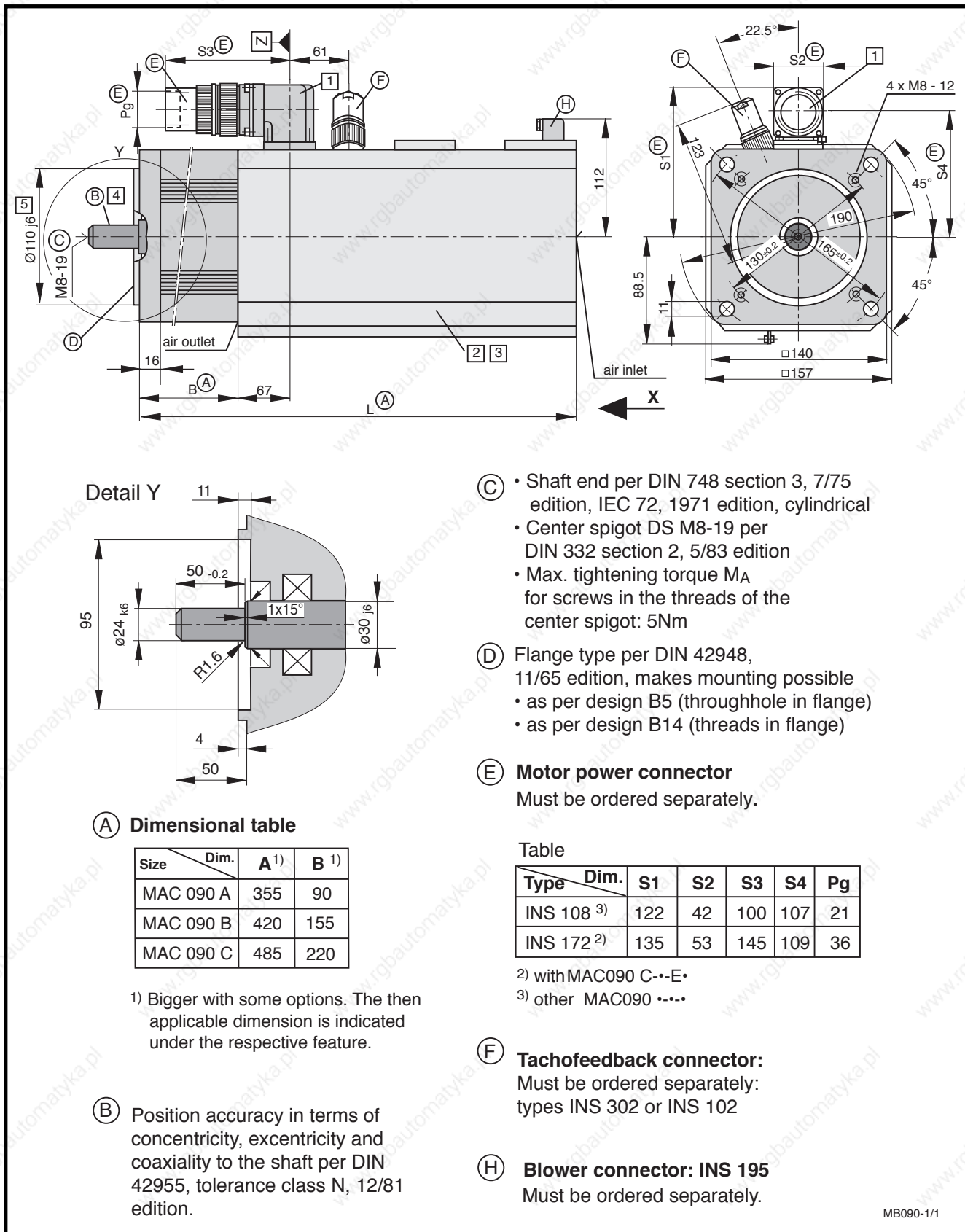

Fig 5.16: Dimensional data - MAC 090 (axial cooling)

Available options

1 Power connection

The output direction of the electrical power connector is selected at the time the order is placed. Possible output directions are:

- to side A
- to side B
- to the right
- to the left

The drawing depicts side A as output direction. The dimensions of any other direction are obtained by a virtual turning of the connector housing around the Z axis.

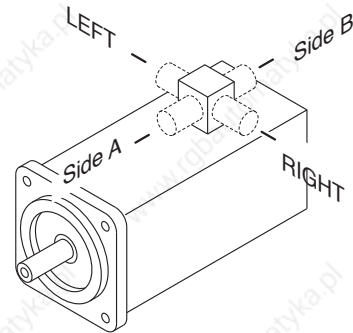

2 Motor version

- Tachofeedback and mounted incremental encoder

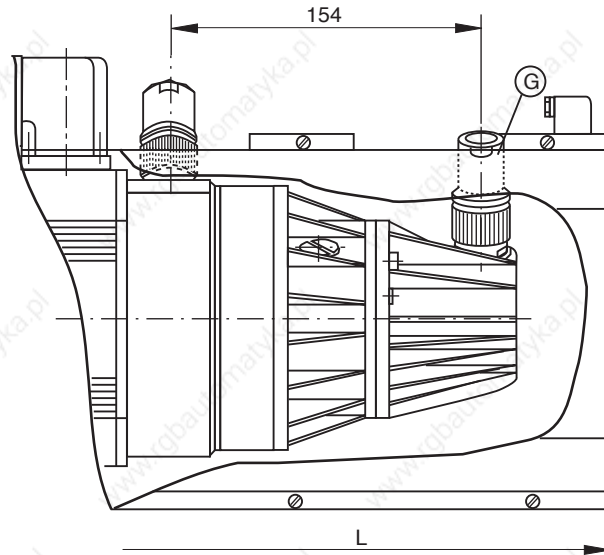
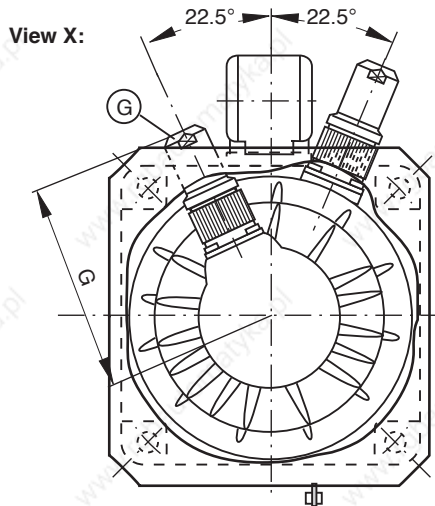

G Incremental encoder connector

Must be ordered separately.

| Name | Conn. type | Dim. G |
|----------|------------|--------|
| straight | INS 301 | 123 |
| conn. | INS 101 | 125 |

Table:

| Size | Dim. | L | B |
|-----------|------|-----|-----|
| MAC 090 A | | 455 | 90 |
| MAC 090 B | | 520 | 155 |
| MAC 090 C | | 585 | 220 |

- Tachofeedback and mounted absolute encoder (see following page)

MB090-1/2

Fig 5.17: Dimensional data - MAC 090 - available options - (axial cooling)

Available options

- Tachofeedback and mounted absolute encoder

View X:

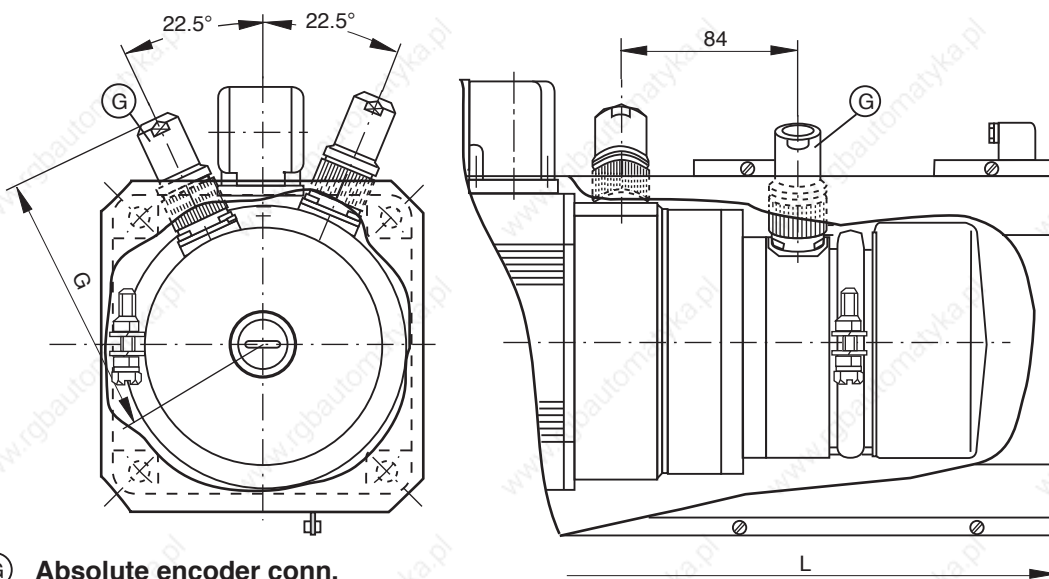

Ⓒ **Absolute encoder conn.**
Must be ordered separately.

| Name | Conn. type | Dim. G |
|----------------|------------|--------|
| straight conn. | INS 326 | 104 |
| | INS 92 | 106 |

| Size | Dim. | L | B |
|-----------|------|-----|-----|
| MAC 090 A | | 455 | 90 |
| MAC 090 B | | 520 | 155 |
| MAC 090 C | | 585 | 220 |

3 Blocking brake

- without blocking brake
Dim. L and B retained
- Standard blocking brake: 6.5 Nm
Dim. L and B retained
- heavy-duty holding brake: 14.0 Nm

Table for blocking brake with 14.0 Nm holding torque

| Size | Dim. | | Vers. 2 | | Vers. 4 | |
|-----------|------|-----|---------|-----|---------|---|
| | L | B | L | B | L | B |
| MAC 090 A | 405 | 140 | 505 | 140 | | |
| MAC 090 B | 470 | 205 | 570 | 205 | | |
| MAC 090 C | 535 | 270 | 635 | 270 | | |

Vers. 2 = Motor with tachofeedback

Vers. 4 = Motor with tachofeedback and mounted encoder

4 Output shaft

- plain shaft (recommended type)
- with keyway per DIN 6885 sh. 1, 8/68 edition
(Note! balanced with entire key.)

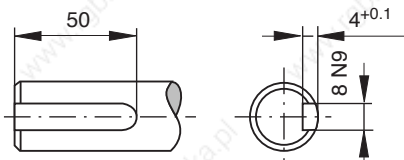

Matching key: DIN 6885-A 8 x 7 x 50
Must be ordered separately.

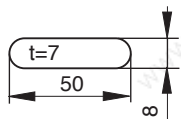

5 Special centering diameter

- Ø130 j6

MB090-1/3

Fig 5.18: Dimensional data - MAC 090 -available options - (axial cooling)

5.7. Available Options

| | | | |
|--|-----------------|--|-------------|
| Type code fields | | Example: MAC 090 A-0-ES-4 - C/110-A-0/WI 520LV/S000 | |
| 1. Motor for analogue drives | MAC | | |
| 2. Motor size | 090 | | |
| 3. Motor length | A, B, C | | |
| 4. Type of cooling: | | | |
| natural convection | | surface cooling | |
| | | axial | |
| | | radial | |
| | | blower right | |
| | | blower below | |
| | | blower left | |
| | | AC 230 V | |
| | | AC 115 V | |
| | | AC 230 V | |
| | | AC 115 V | |
| | | AC 230 V | |
| | | AC 115 V | |
| 0 | 1 ¹⁾ | 2 ¹⁾ | 6 A 7 B 8 C |
| 5. Type of windings | | | |
| Nominal rpm | | Standard applications | |
| | | with increased smooth run quality | |
| | | motor length | |
| | | motor length | |
| | | A B B C A B B C | |
| 2000 min ⁻¹ | ZD PD -- KD | ZG PG -- KG | |
| 3000 min ⁻¹ | RD ND JD GD | RG NG JG GG | |
| 5000 min ⁻¹ | -- -- -- ED | -- -- -- EG | |
| 6. Motor feedback | | | |
| Motor type | | | |
| with tachofeedback | | 2 | |
| with tachofeedback and second shaft end | | 3 | |
| with tachofeedback and mounted incremental or absolute encoder | | 4 | |
| Tacho voltage | | | |
| set to nominal motor speed | | - | |
| (nominal rpm > 3000 min ⁻¹ : 1,5 V/1000 min ⁻¹) | | | |
| (nominal rpm ≤ 3000 min ⁻¹ : 3 V/1000 min ⁻¹) | | | |
| 1,5 V/1000 min ⁻¹ | | H | |
| 6 V/1000 min ⁻¹ | | L | |
| Tacho type | | | |
| Standard | | C | |
| increased smooth run quality | | F | |
| 7. Centering diameter | | | |
| for design B05 and B14 | | 110 | |
| for design B05 and B14 | | 130 ²⁾ | |
| 8. Power connection | | | |
| connector to side A | | A | |
| connector to side B | | B | |
| connector to right (looking onto output shaft) | | R | |
| connector to left (looking onto output shaft) | | L | |
| 9. Blocking brake | | | |
| without blocking brake | | 0 | |
| with standard blocking brake (6.5 Nm) | | 1 | |
| with heavy-duty blocking brake (14 Nm) | | 2 | |
| 10. Type ³⁾ | | | |
| Incremental encoder with standard mounting | | WI | |
| Incremental encoder with shock-damped mounting | | DI | |
| 11. Encoder code ³⁾ | | | |
| For available types, see section 2.4 "Motor feedback" | | | |
| 12. Special types | | | |
| Fixed and documented by INDRAMAT with special number (see Drawing no.: 106-0105-4301-XX) | | | |
| Does not apply to standard motors. | | | |
| 1) For type 3 motors (with 2nd shaft end and tachofeedback). Not available with axial surface cooling. | | | |
| 2) additional S0 no. required (see Fig. 5.20) | | | |
| 3) type code fields 10 and 11 do not apply to motor types 2 and 3 | | | |

Fig 5.19: Type codes - MAC 090

TLMAC090

5.8. Special Options

| Specification of Option | S003 | S005 | S012 | S013 | S019 | S023 | S031 |
|---------------------------------|------|------|------|------|------|------|------|
| Special centering diameter 130 | X | | X | | X | | X |
| Heavy-duty blocking brake | | | | X | X | X | X |
| output shaft with shaft sealing | | X | X | | | X | X |

Fig 5.20: Special options with a MAC 090

6. MAC 093

6.1. Technical Data

| Designation | Symbol | Unit | Motor type MAC ... | | |
|---|-------------------|-------------------|--------------------------|---------------------------|---------------------------|
| | | | 093 A - - - WS | 093 B - - - OS | 093 C - - - KS |
| Nominal motor speed ¹⁾ | n | min ⁻¹ | 2000 | 2000 | 2000 |
| Continuous torque at standstill ²⁾ | M _{dN} | Nm | 9.2 (12.0) ⁵⁾ | 14.5 (20.0) ⁵⁾ | 19.5 (28.0) ⁵⁾ |
| Continuous current at standstill | I _{dN} | A | 11(14) ⁵⁾ | 18 (25) ⁵⁾ | 22 (32) ⁵⁾ |
| Rotor moment of inertia ³⁾ | J _M | kgm ² | 22 x 10 ⁻⁴ | 29 x 10 ⁻⁴ | 42 x 10 ⁻⁴ |
| Torque constant at 20 °C | K _m | Nm/A | 0.875 | 0.831 | 0.910 |
| Windings resistance at 20 °C | R _A | Ohm | 1.313 | 0.625 | 0.433 |
| Windings inductance | L _A | mH | 16.0 | 9.0 | 7.0 |
| Maximum peak of pulse current | I _{peak} | A | 54 | 89 | 110 |
| Thermal time constant | T _{th} | min | 50 (30) ⁵⁾ | 50 (45) ⁵⁾ | 50 (45) ⁵⁾ |
| Mass ⁴⁾ | m _M | kg | 13.0 | 16.5 | 22.0 |
| | | | 093 A - - - PS | 093 B - - - JS | 093 C - - - FS |
| Nominal motor speed ¹⁾ | n | min ⁻¹ | 3000 | 3000 | 3000 |
| Continuous torque at standstill ²⁾ | M _{dN} | Nm | 9.2 (12.0) ⁵⁾ | 14.5 (18.3) ⁵⁾ | 19.5 (28.0) ⁵⁾ |
| Continuous current at standstill | I _{dN} | A | 15 (20) ⁵⁾ | 27 (34) ⁵⁾ | 35 (50) ⁵⁾ |
| Rotor moment of inertia ³⁾ | J _M | kgm ² | 22 x 10 ⁻⁴ | 29 x 10 ⁻⁴ | 42 x 10 ⁻⁴ |
| Torque constant at 20 °C | K _m | Nm/A | 0.620 | 0.554 | 0.579 |
| Windings resistance at 20 °C | R _A | Ohm | 0.659 | 0.227 | 0.175 |
| Windings inductance | L _A | mH | 8.0 | 4.0 | 2.9 |
| Maximum peak of pulse current | I _{peak} | A | 76 | 134 | 173 |
| Thermal time constant | T _{th} | min | 50 (45) ⁵⁾ | 50 (45) ⁵⁾ | 50 (45) ⁵⁾ |
| Mass ⁴⁾ | m _M | kg | 13.0 | 16.5 | 22.0 |
| | | | 093 A - - - LS | 093 B - - - GS | 093 C - - - DS |
| Nominal motor speed ¹⁾ | n | min ⁻¹ | 4000 | 4000 | 4000 |
| Continuous torque at standstill ²⁾ | M _{dN} | Nm | 9.2 (12.0) ⁵⁾ | 14.5 (20.0) ⁵⁾ | 19.5 (28.0) ⁵⁾ |
| Continuous current at standstill | I _{dN} | A | 22 (28) ⁵⁾ | 38 (53) ⁵⁾ | 48 (69) ⁵⁾ |
| Rotor moment of inertia ³⁾ | J _M | kgm ² | 22 x 10 ⁻⁴ | 29 x 10 ⁻⁴ | 42 x 10 ⁻⁴ |
| Torque constant at 20 °C | K _m | Nm/A | 0.438 | 0.388 | 0.413 |
| Windings resistance at 20 °C | R _A | Ohm | 0.328 | 0.136 | 0.089 |
| Windings inductance | L _A | mH | 4.0 | 2.0 | 1.5 |
| Maximum peak of pulse current | I _{peak} | A | 108 | 192 | 242 |
| Thermal time constant | T _{th} | min | 50 (45) ⁵⁾ | 50 (45) ⁵⁾ | 50 (45) ⁵⁾ |
| Mass ⁴⁾ | m _M | kg | 13.0 | 16.5 | 22.0 |
| | | | 093 A - - - HS | 093 B - - - ES | 093 C - - - CS |
| Nominal motor speed ¹⁾ | n | min ⁻¹ | 6000 | 6000 | 6000 |
| Continuous torque at standstill ²⁾ | M _{dN} | Nm | 9.2 (9.8) ⁵⁾ | 14.5 (20.0) ⁵⁾ | 19.5 (28.0) ⁵⁾ |
| Continuous current at standstill | I _{dN} | A | 32 (34) ⁵⁾ | 54 (74) ⁵⁾ | 60 (87) ⁵⁾ |
| Rotor moment of inertia ³⁾ | J _M | kgm ² | 22 x 10 ⁻⁴ | 29 x 10 ⁻⁴ | 42 x 10 ⁻⁴ |
| Torque constant at 20 °C | K _m | Nm/A | 0.292 | 0.277 | 0.331 |
| Windings resistance at 20 °C | R _A | Ohm | 0.146 | 0.069 | 0.057 |
| Windings inductance | L _A | mH | 1.8 | 1.0 | 0.9 |
| Maximum peak of pulse current | I _{peak} | A | 162 | 268 | 302 |
| Thermal time constant | T _{th} | min | 50 (45) ⁵⁾ | 50 (45) ⁵⁾ | 50 (45) ⁵⁾ |
| Mass ⁴⁾ | m _M | kg | 13.0 | 16.5 | 22.0 |

¹⁾ The usable motor speed is determined by the drive used.
 Only those usable speeds n_{max} found in the selection lists of the motor-drive combinations are binding.
²⁾ With 60K overtemperature at the motor housing.
 Continuous torque can be limited by the drive. See selection data.
³⁾ With tacho-generator, without holding brake
⁴⁾ With tacho-generator, without holding brake, without blower.
⁵⁾ Parenthetical values apply to versions with surface cooling.

Fig 6.1: Type-dependent motor data

| Designation | Symbol | Unit | Data | |
|--|----------|-------------------------------|--------------------------------|------------------|
| Permissible ambient temperature | T_{um} | °C | 0 ... + 45 | |
| Permissible storage and transport temperature | T_L | °C | -20 ... +80 | |
| Maximum installation elevation | | m | 1000 m. above sea level | |
| Protection category | | | IP 65 | |
| Insulation classification | | | F | |
| Housing coat | | | Black prime coat (RAL 9005) | |
| Voltage constant of the tachogenerator ¹⁾ | C_w | Vs/rad V/min ⁻¹ | 0.0143 1.5/1000 | 0.0286 3/1000 |

¹⁾ Tachovoltage can be selected application-related.

Fig 6.2: General data MAC 093

| Designation | Symbol | Unit | Data holding brake | | |
|---------------------|--------|------------------|-------------------------|---|------------------------|
| | | | Standard | heavy-duty electrically actuated release | extra heavy-duty |
| Principle of action | | | | | |
| Holding torque | M_H | Nm | 6.5 | 14 | 22 |
| Nominal voltage | U_N | V | | DC 24 ± 10% | |
| Nominal current | I_N | A | 0.7 | 0.7 | 0.7 |
| Moment of inertia | J_B | kgm ² | 1.06 x 10 ⁻⁴ | 3.6 x 10 ⁻⁴ | 3.6 x 10 ⁻⁴ |
| Release delay | t_L | ms | 60 | 70 | 70 |
| Clamping delay | t_K | ms | 20 | 30 | 30 |
| Mass | m_B | kg | 0.6 | 1.1 | 1.1 |

Fig 6.3: Technical data - holding brake

| Designation | Symbol | Unit | Axial cooling | Radial cooling |
|----------------------------------|--------|------|-----------------------------|-----------------------------|
| Power consumption | S_N | VA | 40/42 | 40/42 |
| Nominal voltage | U_N | V | AC 230 or 115 ¹⁾ | AC 230 or 115 ¹⁾ |
| Frequency | f | Hz | 50/60 | 50/60 |
| Mass | m_L | kg | approx. 3.3 ²⁾ | approx. 3.2 ²⁾ |
| Protection category blower unit | | | IP 24 | IP 24 |
| Protection category blower motor | | | IP 44 | IP 44 |

¹⁾ 115 V special design
²⁾ Blower shroud for motor with tachofeedback.

Fig 6.4: Technical data - surface cooling

6.2. Torque-Speed Characteristics

MAC 093 A - - - WS
2000 min⁻¹

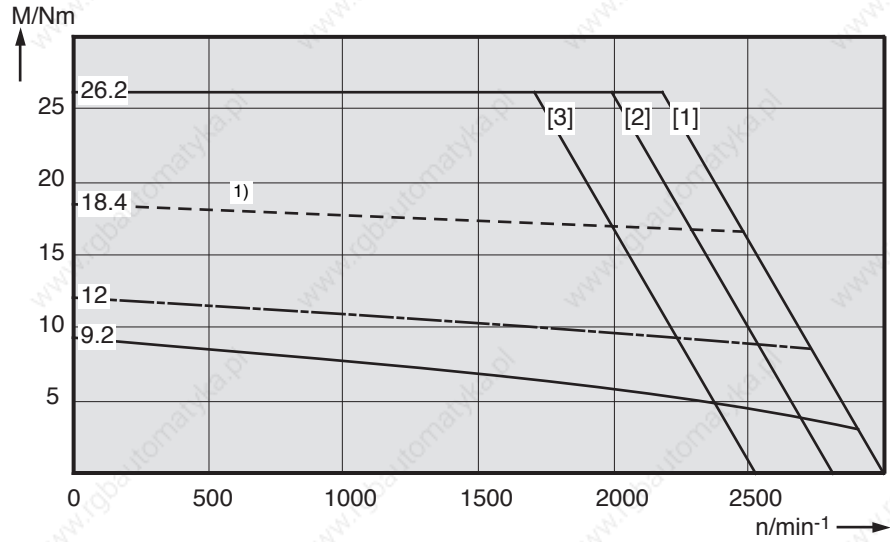

MAC 093 A - - - PS
3000 min⁻¹

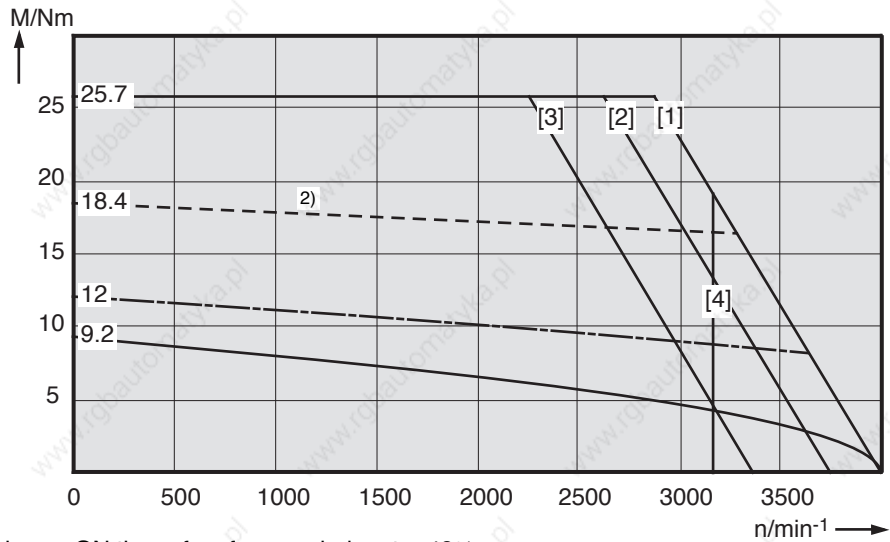

1) shown: ON time of surface-cooled motor 48%
2) shown: ON time of surface-cooled motor 40%

Fig 6.5: Torque-speed characteristics MAC 093

MAC 093 A - - - LS
4000 min⁻¹

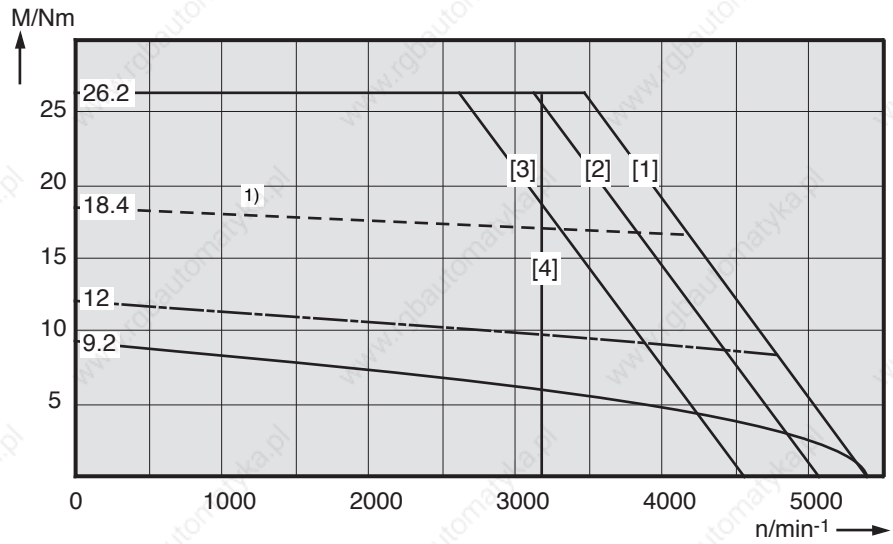

MAC 093 A - - - HS
6000 min⁻¹

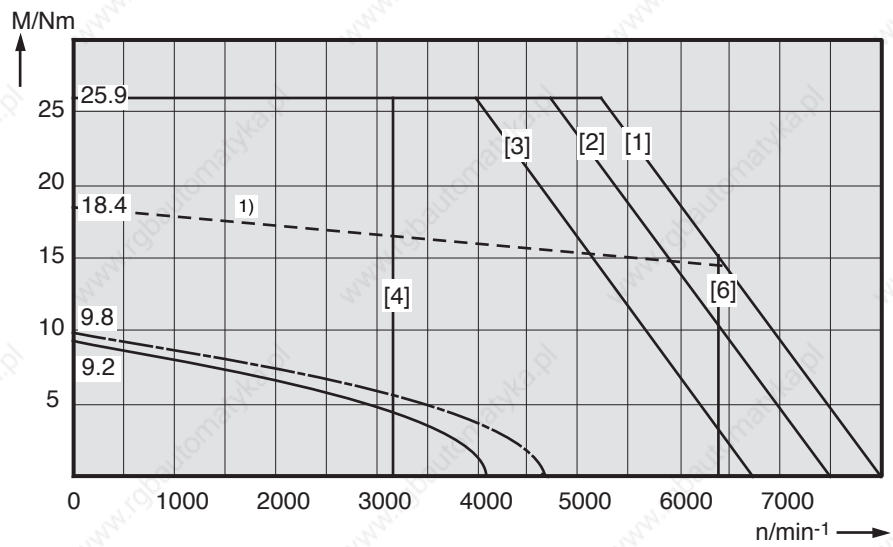

1) shown: ON time of surface-cooled motor 48%

Fig 6.6: Torque-speed characteristics MAC 093

MAC 093 B - • - OS
2000 min⁻¹

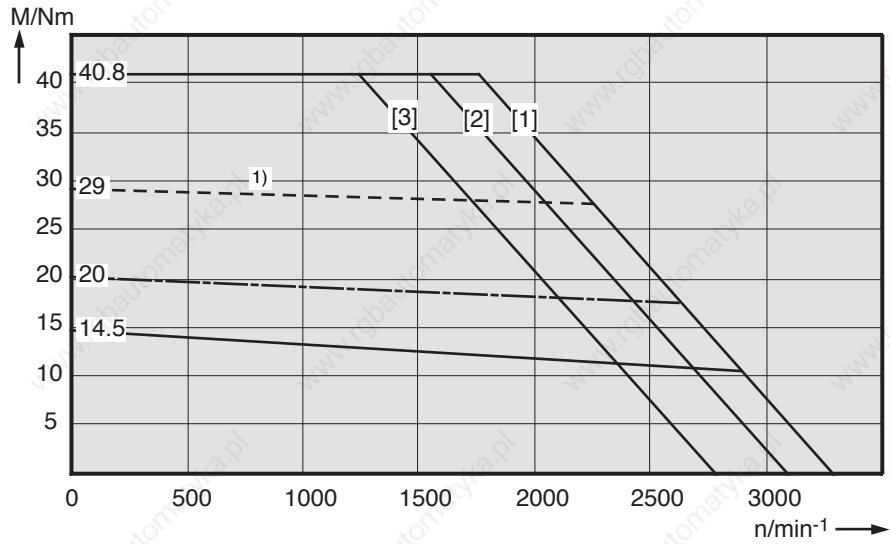

MAC 093 B - • - JS
3000 min⁻¹

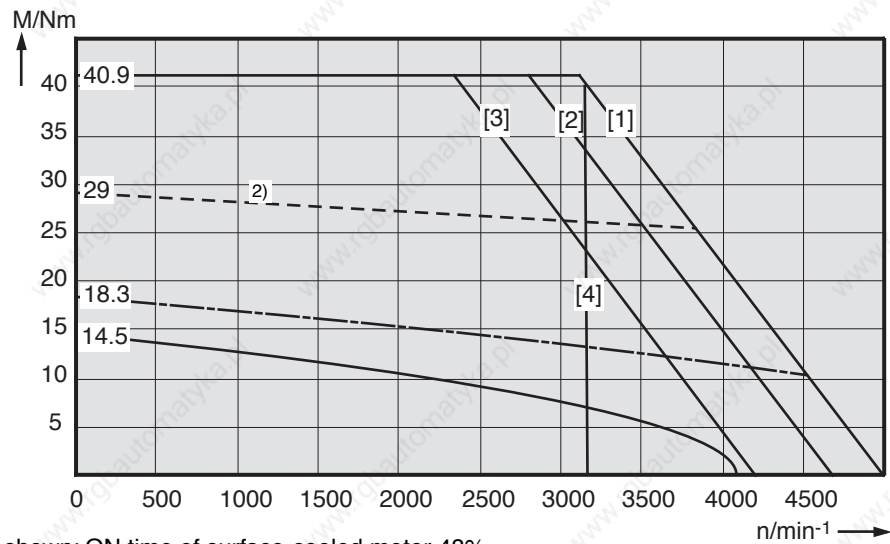

1) shown: ON time of surface-cooled motor 48%
1) shown: ON time of surface-cooled motor 40%

Fig 6.7: Torque-speed characteristics MAC 093

MAC 093 B - - - GS
4000 min⁻¹

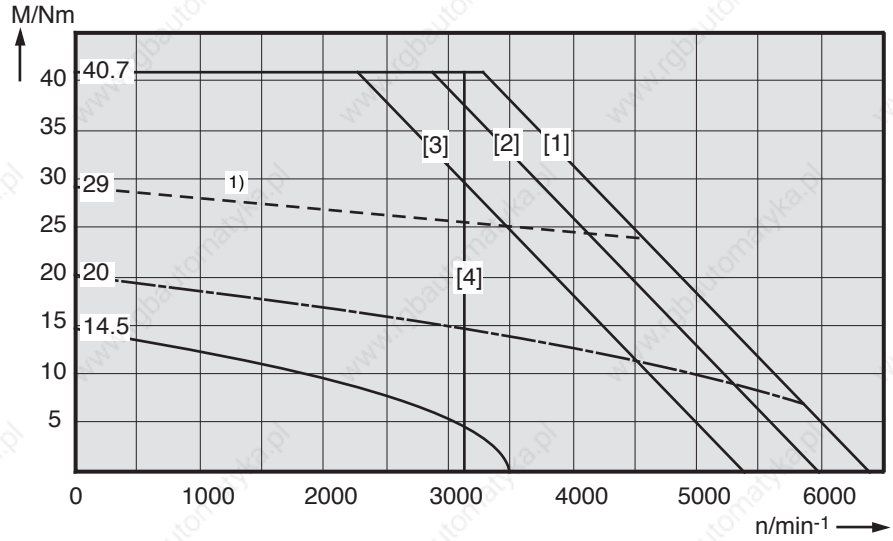

MAC 093 B - - - ES
6000 min⁻¹

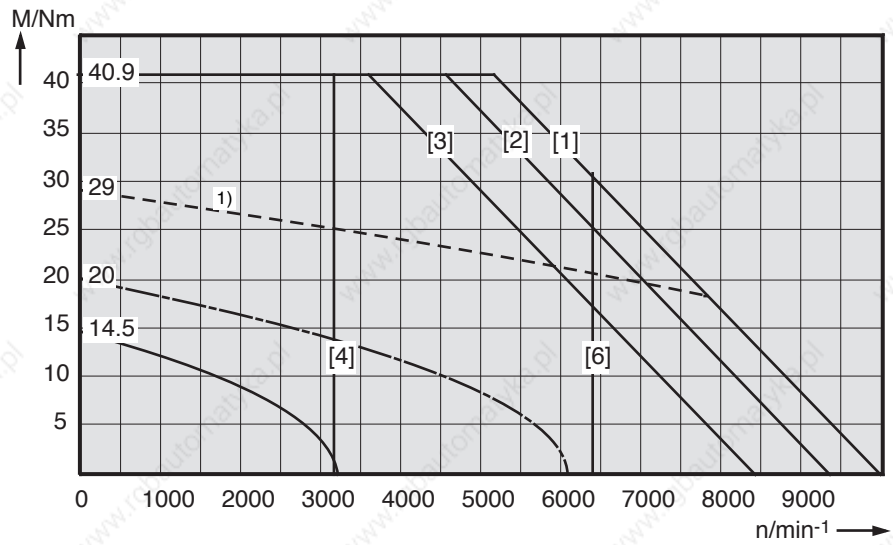

1) shown: ON time of surface-cooled motor 48%

Fig 6.8: Torque-speed characteristics MAC 093

MAC 093 C - - - KS
2000 min⁻¹

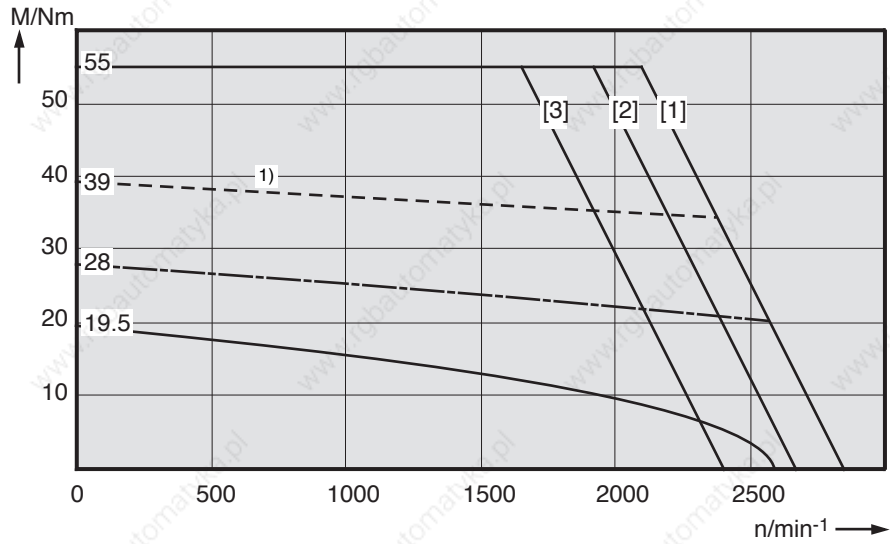

MAC 093 C - - - FS
3000 min⁻¹

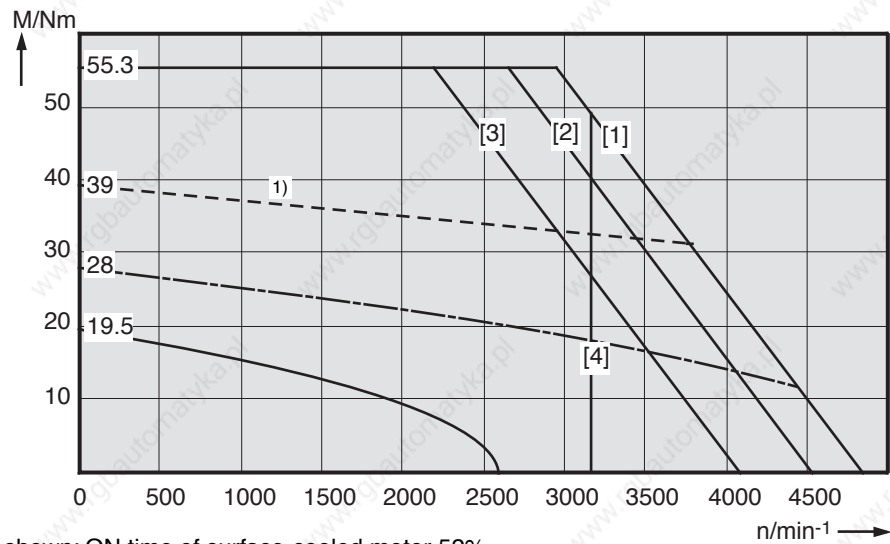

¹⁾ shown: ON time of surface-cooled motor 52%

Fig 6.9: Torque-speed characteristics MAC 093

MAC 093 C - - - DS
4000 min⁻¹

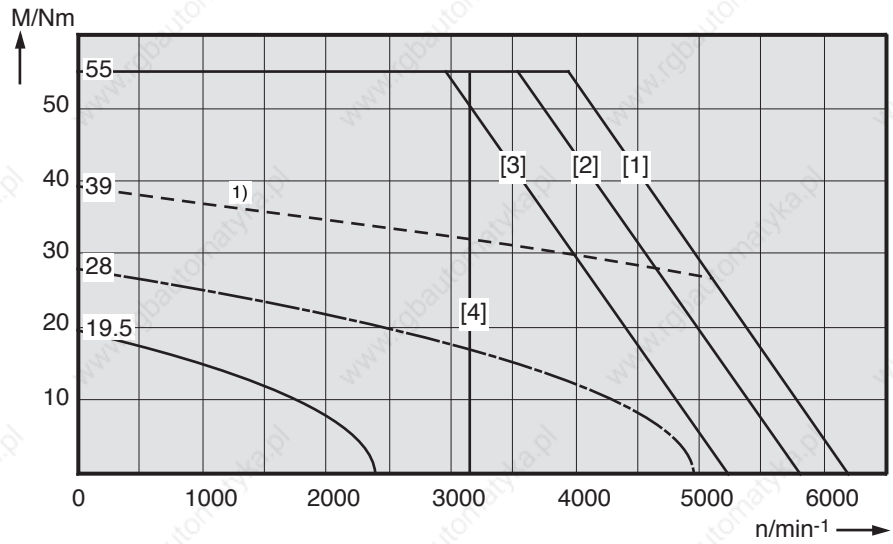

MAC 093 C - - - CS
6000 min⁻¹

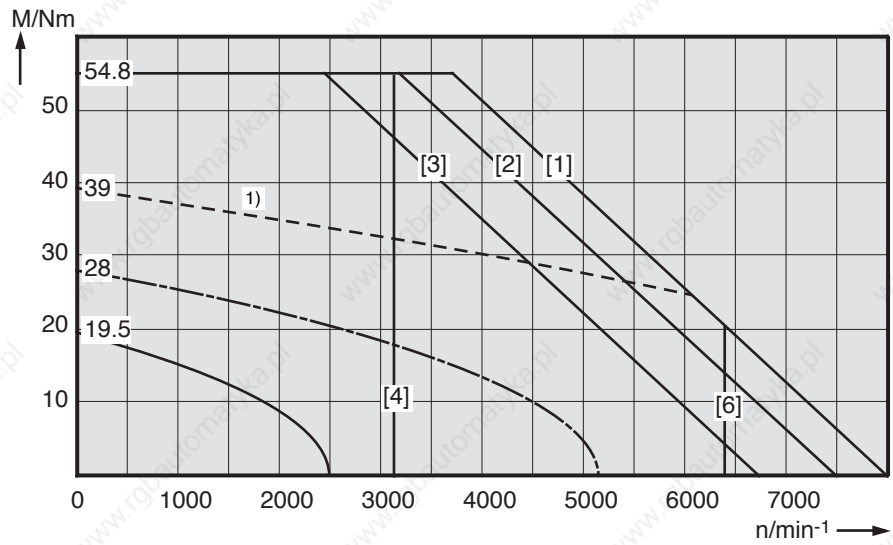

1) shown: ON time of surface-cooled motor 52%

Fig 6.10: Torque-speed characteristics MAC 093

6.3. Shaft load capacity

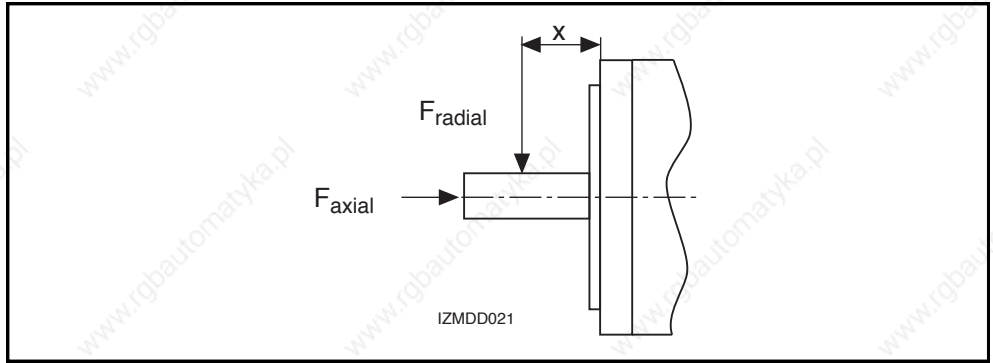

Fig 6.11: Shaft load

Permissible radial force
 F_{radial}

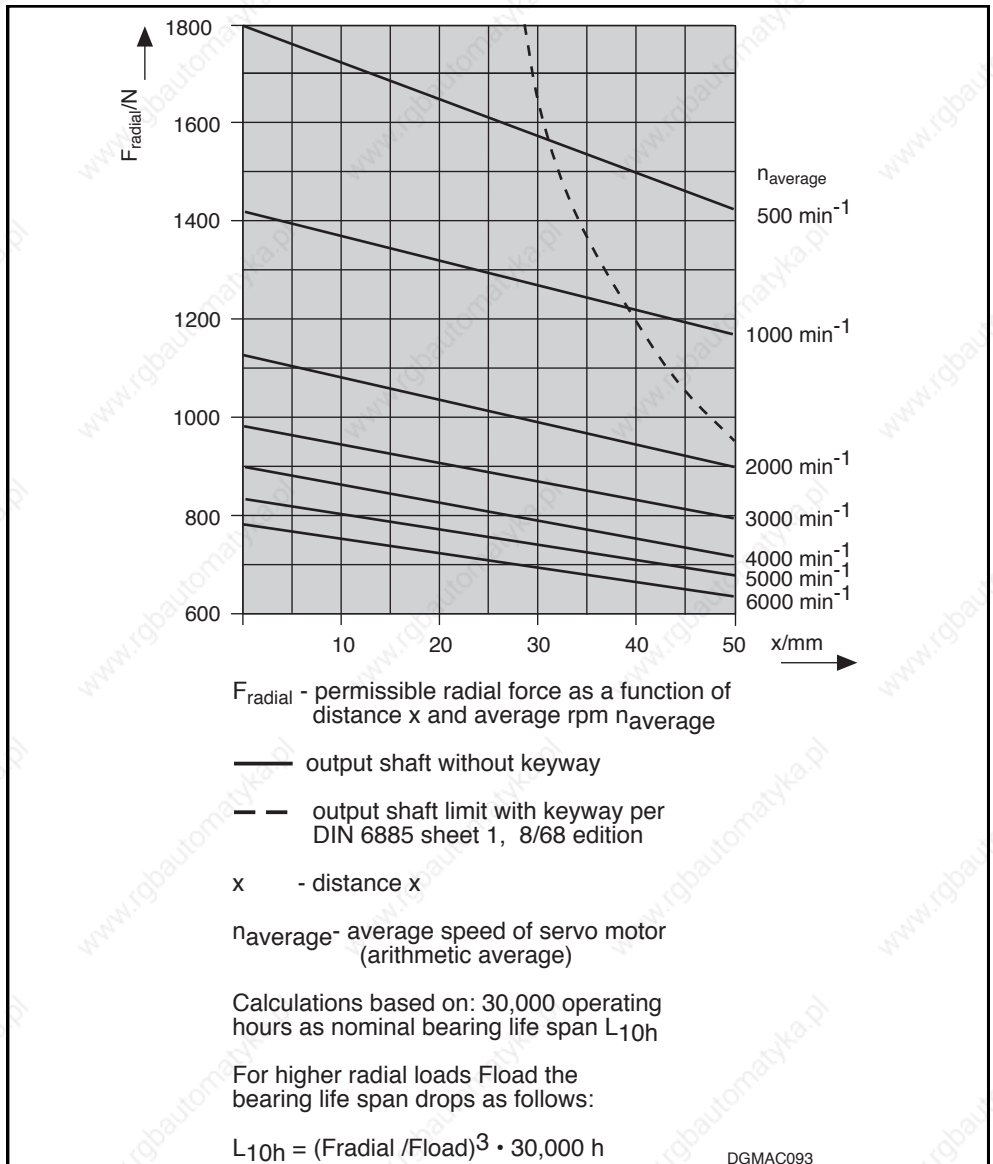

Fig 6.12: Permissible radial force

Permissible axial force
 F_{axial}

$$F_{axial} = 0.34 \cdot F_{radial}$$

F_{axial} - Permissible axial force
 F_{radial} - Permissible radial force

6.4. Dimensional data - natural convection

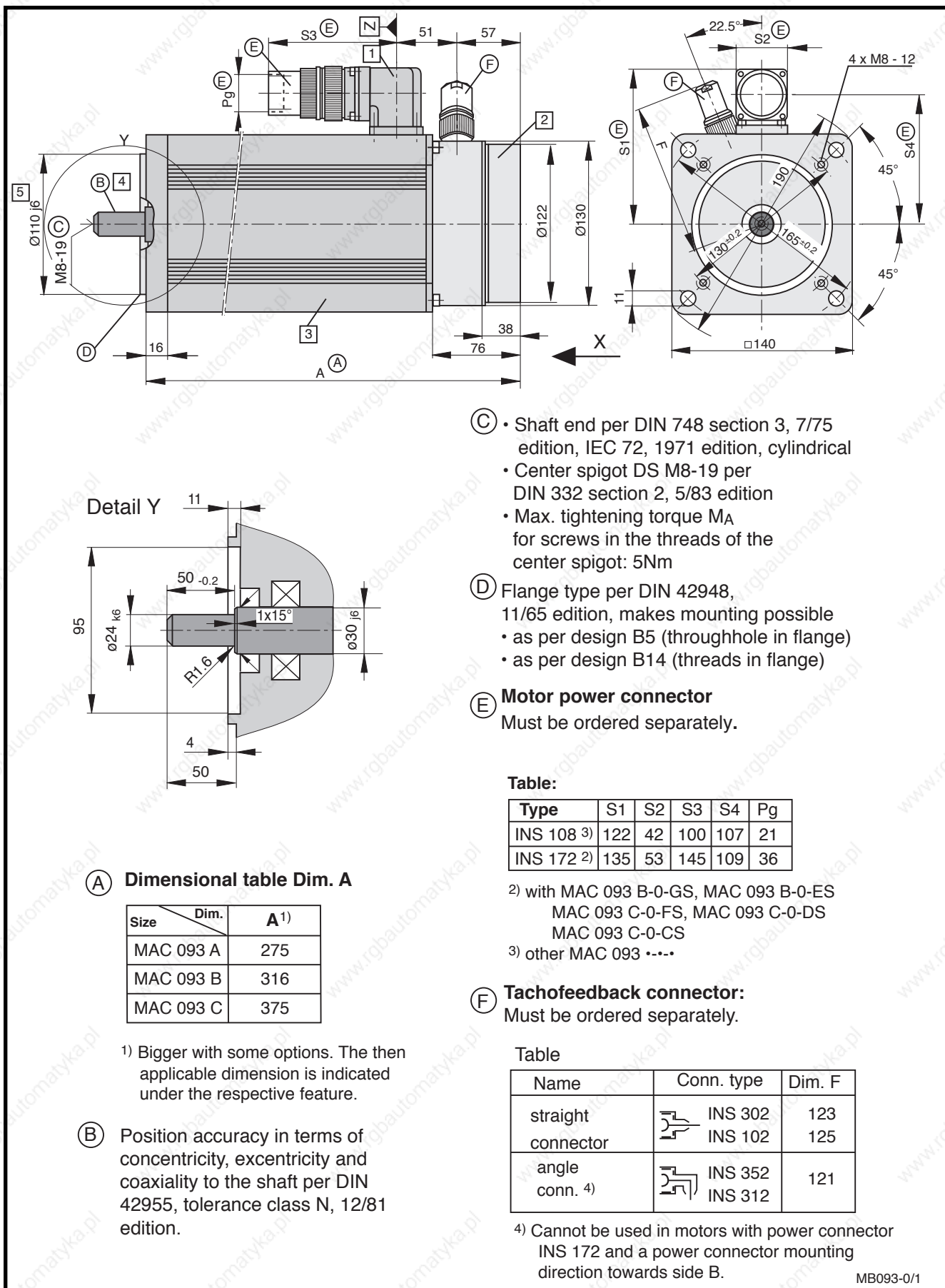

Fig 6.13: Dimensional data - MAC 093 (natural convection)

Available options

1 Power connection

The output direction of the electrical power connector is selected at the time the order is placed. Possible output directions are:

- to side A
- to side B
- to the right
- to the left

The drawing depicts side A as output direction. The dimensions of any other direction are obtained by a virtual turning of the connector housing around the Z axis.

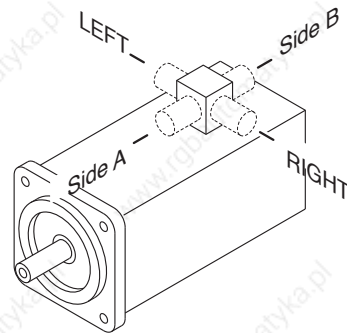

2 Motor version

- Tachofeedback and second shaft end

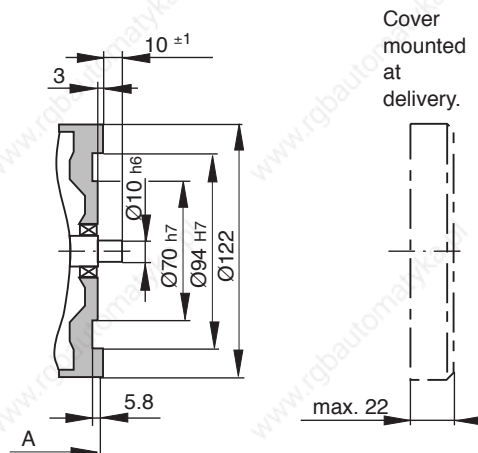
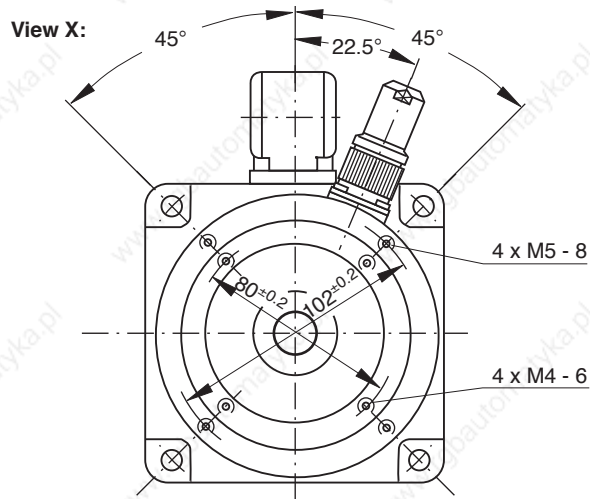

- Tachofeedback and mounted incremental encoder

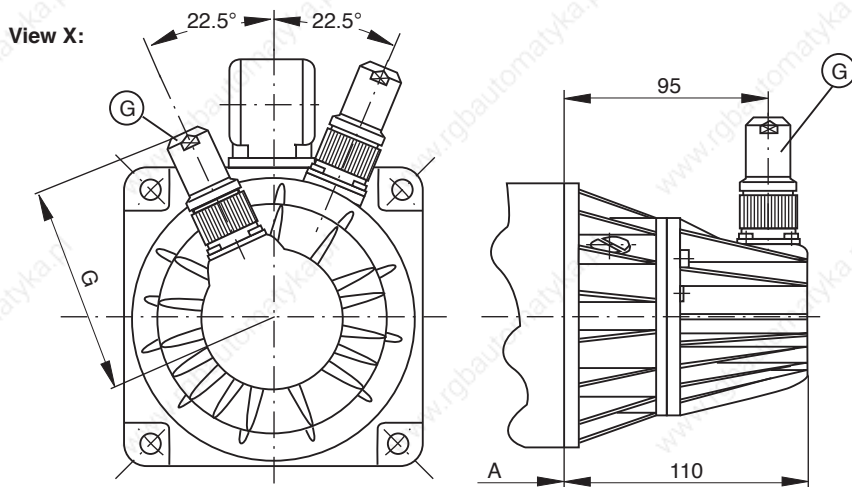

G Incremental encoder connector

Must be ordered separately.

| Name | Conn. type | Dim. G |
|----------------|------------|--------|
| straight conn. | INS 301 | 88 |
| | INS 101 | 90 |
| angle conn. | INS 351 | 86 |
| | INS 311 | |

- Tachofeedback and mounted absolute encoder (see following page)

MB093-0/2

Fig 6.14: Dimensional data - MAC 093 - available options - (natural convection)

Available options

- Tachofeedback and mounted absolute encoder

View X:

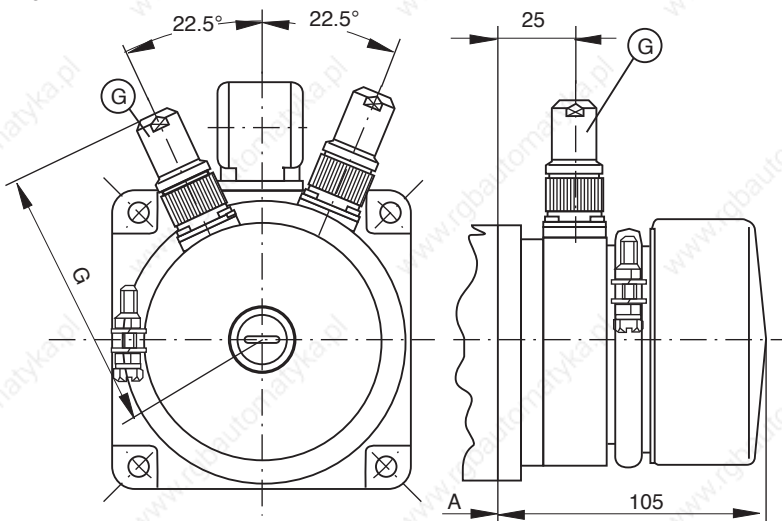

Ⓒ **Absolute encoder conn.**
Must be ordered separately.

| Name | Conn. type | Dim. G |
|----------------|------------|--------|
| straight conn. | INS 326 | 104 |
| | INS 92 | 106 |
| angle conn. | INS 322 | 102 |

3 Blocking brake

- without blocking brake
Dim. A retained
- Standard blocking brake: 6.5 Nm
Dim. A. retained
- heavy-duty blocking brake: 14.0 Nm
- extra heavy-duty blocking brake: 22.0 Nm

Table for blocking brake with 14 and 22 Nm

| Size | Dim. A |
|-----------|--------|
| MAC 093 A | 305 |
| MAC 093 B | 346 |
| MAC 093 C | 405 |

4 Output shaft

- plain shaft (recommended type)
- with keyway per DIN 6885 sh. 1, 8/68 edition
(Note! balanced with entire key.)

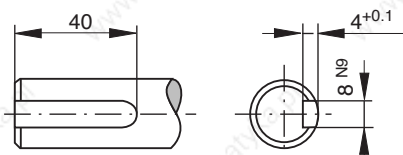

Matching key: DIN 6885-A 8 x 7 x 40
Must be ordered separately

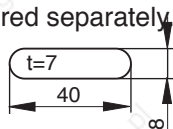

5 Special centering diameter

- Ø130 j6

MB093-0/3

Fig 6.15: Dimensional data - MAC 093 - available options - (natural convection)

6.5. Dimensional data - radial cooling

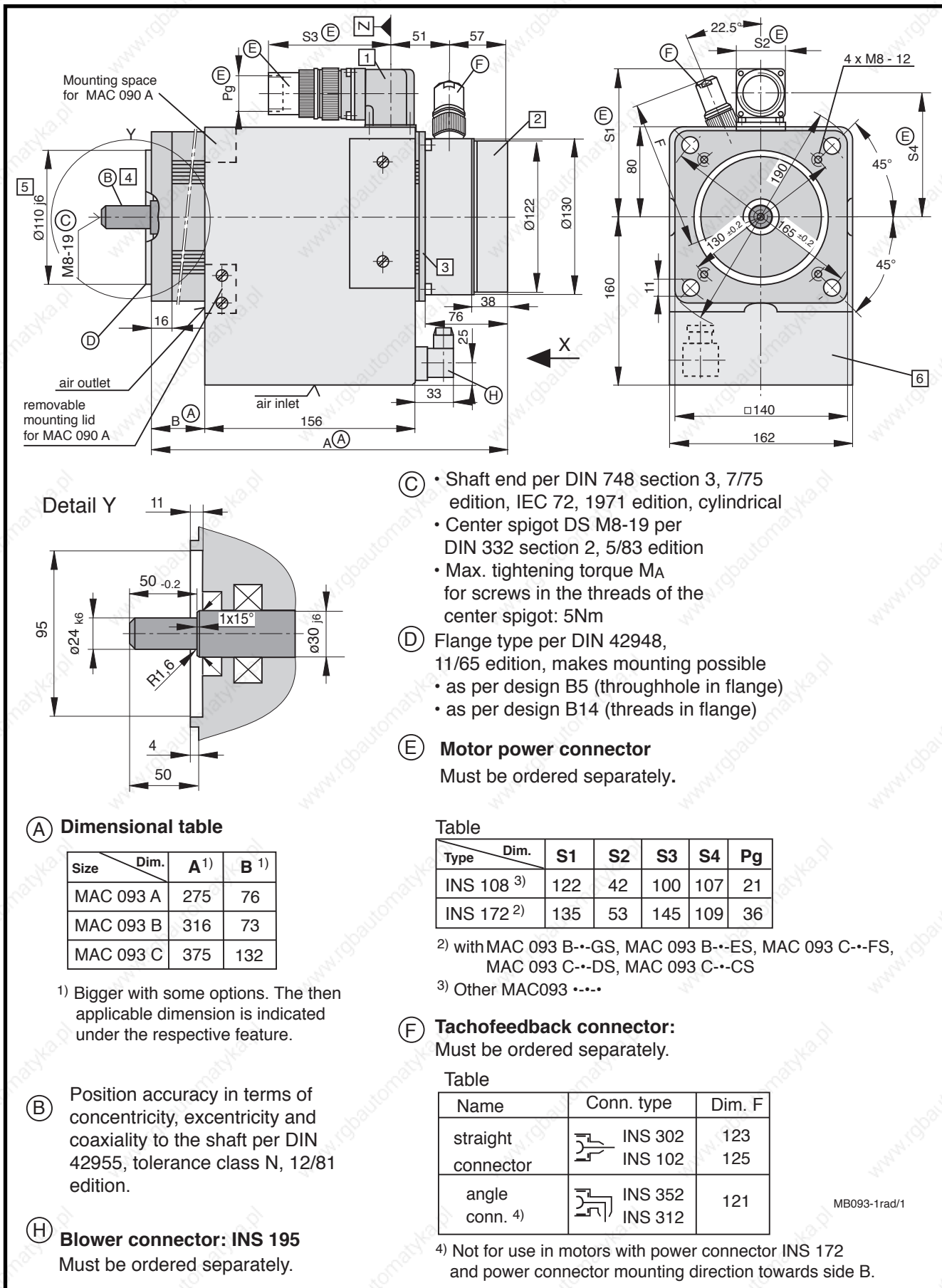

Fig 6.16: Dimensional data - MAC 093 (radial cooling)

Available options

1 Power connection

The output direction of the electrical power connector is selected at the time the order is placed. Possible output directions are:

- to side A
- to side B
- to the right
- to the left

The drawing depicts side A as output direction. The dimensions of any other direction are obtained by a virtual turning of the connector housing around the Z axis.

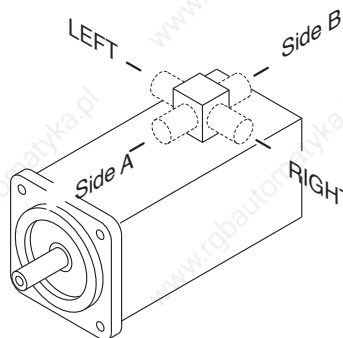

2 Motor version

- Tachofeedback and second shaft end

View X:

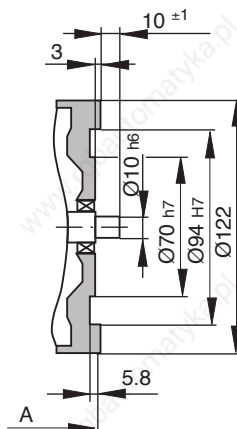
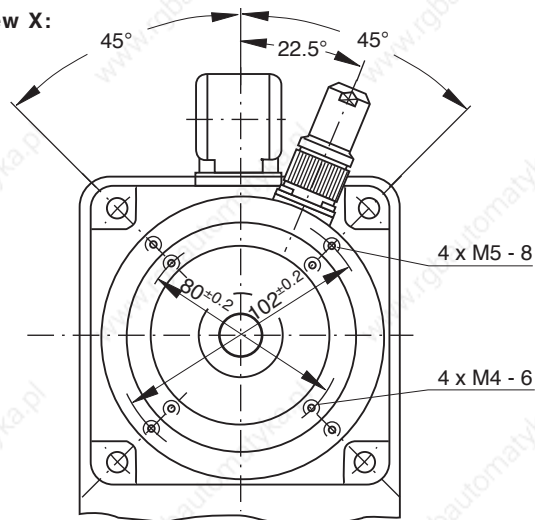

Cover mounted at delivery.

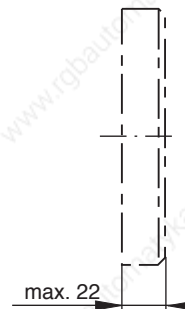

- Tachofeedback and mounted incremental encoder

View X:

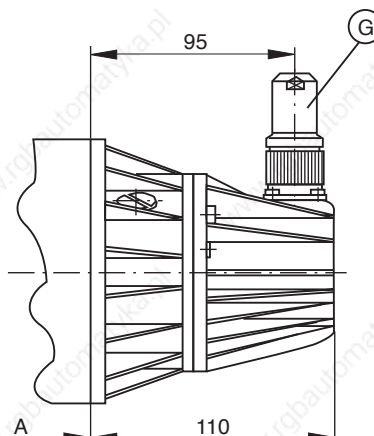
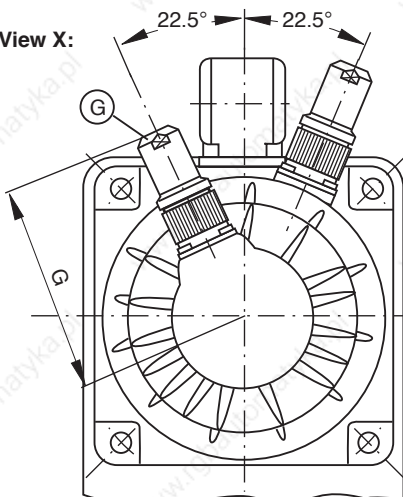

G Incremental encoder connector

Must be ordered separately.

| Name | Conn. type | Dim. G |
|----------------|--------------------|--------|
| straight conn. | INS 301 | 88 |
| | INS 101 | 90 |
| angle conn. | INS 351 INS 311 | 86 |

- Tachofeedback and mounted absolute encoder (see following page)

MB090-1rad/2

Fig 6.17: Dimensional data - MAC 093 - available options - (radial cooling)

Available options

- Tachofeedback and mounted absolute encoder

View X:

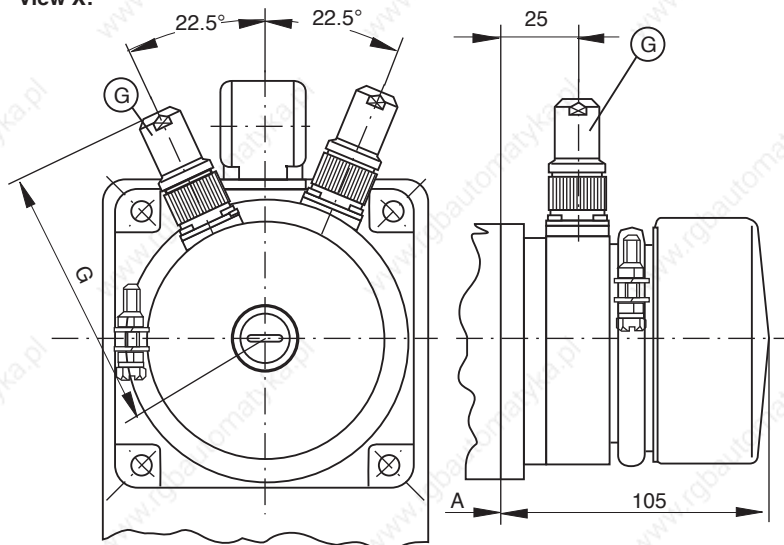

G Absolute encoder conn.
Must be ordered separately.

| Name | Conn. type | Dim. G |
|----------------|------------|--------|
| straight conn. | INS 326 | 104 |
| | INS 92 | 106 |
| angle conn. | INS 322 | 102 |

3 Blocking brake

- without blocking brake
Dim. A and B retained
- Standard blocking brake: 6.5 Nm
Dim. A and B retained
- heavy-duty blocking brake: 14.0 Nm
- extra heavy-duty blocking brake: 22.0 Nm

Table for blocking brake with 14 and 22 Nm

| Size \ Dim. | A | B |
|-------------|-----|-----|
| MAC 093 A | 305 | 106 |
| MAC 093 B | 346 | 103 |
| MAC 093 C | 405 | 162 |

4 Output shaft

- plain shaft (recommended type)
- with keyway per DIN 6885 sh. 1, 8/68 edition
(Note! balanced with entire key.)

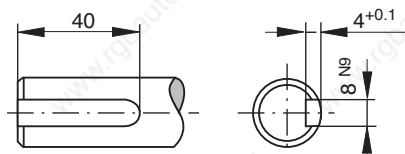

Matching key: DIN 6885-A 8 x 7 x 40
Must be ordered separately.

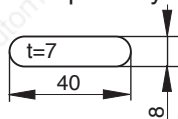

5 Special centering diameter

- $\varnothing 130 j6$

6 Blower arrangement

Looking towards motor shaft.

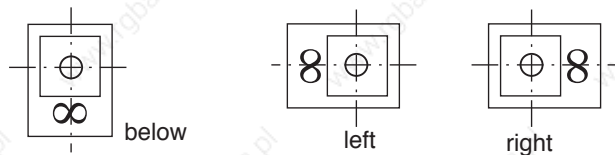

MB093-1rad/3

Fig 6.18: Dimensional data - MAC 093 - available options - (radial cooling)

6.6. Dimensional Data - Axial Cooling

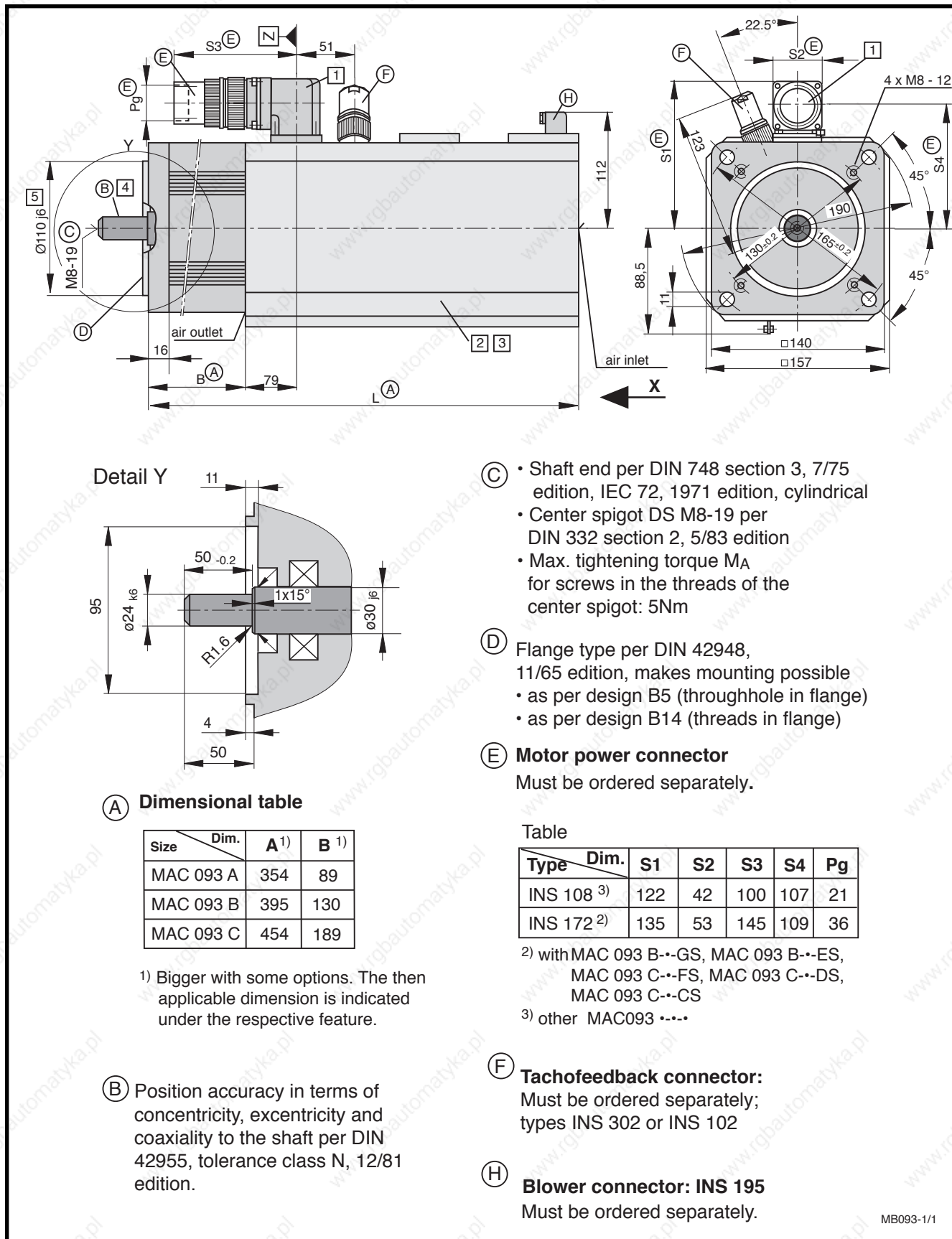

Fig 6.19: Dimensional data - MAC 093 (axial cooling)

Available options

1 Power connection

The output direction of the electrical power connector is selected at the time the order is placed. Possible output directions are:

- to side A
- to side B
- to the right
- to the left

The drawing depicts side A as output direction. The dimensions of any other direction are obtained by a virtual turning of the connector housing around the Z axis.

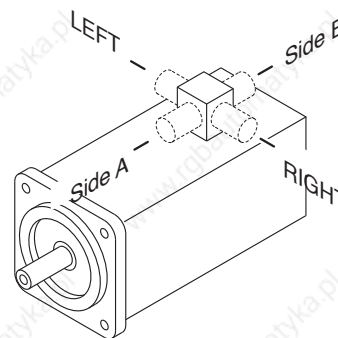

2 Motor version

- Tachofeedback and mounted incremental encoder

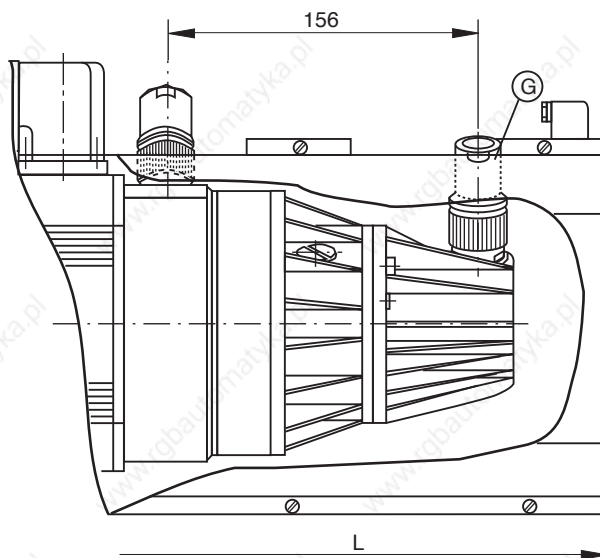
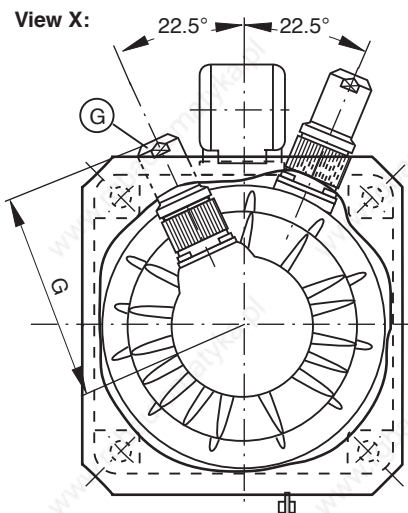

G Incremental encoder connector

Must be ordered separately.



| Name | Conn. type | Dim. G |
|----------|---|--------|
| straight |  INS 301 | 123 |
| conn. |  INS 101 | 125 |

Table:

| Size | Dim. | L | B |
|-----------|------|-----|-----|
| MAC 093 A | | 454 | 89 |
| MAC 093 B | | 495 | 130 |
| MAC 093 C | | 554 | 189 |

MB093-1/2

Fig 6.20: Dimensional data - MAC 093 - available options - (axial cooling)

Available options

- Tachofeedback and mounted absolute encoder

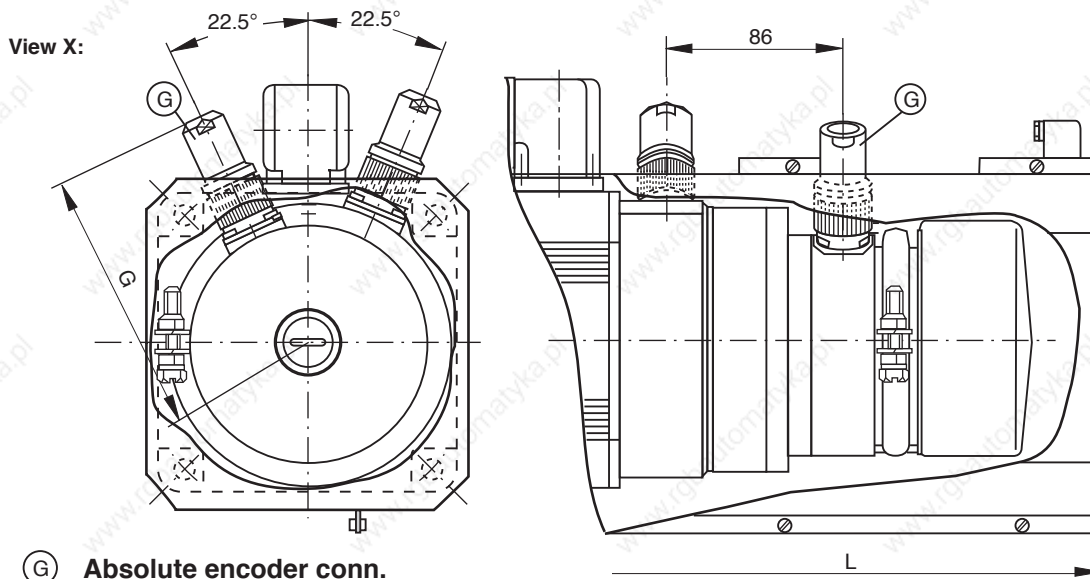

G Absolute encoder conn.
Must be ordered separately.

| Name | Conn. type | Dim. G |
|----------------|------------|--------|
| straight conn. | INS 326 | 104 |
| | INS 92 | 106 |

| Size | Dim. | L | B |
|-----------|------|-----|-----|
| MAC 093 A | | 454 | 89 |
| MAC 093 B | | 495 | 130 |
| MAC 093 C | | 554 | 189 |

3 Blocking brake

- without blocking brake
Dim. L and B retained
- Standard blocking brake: 6.5 Nm
Dim. L and B retained
- heavy-duty blocking brake: 14.0 Nm
- extra heavy-duty blocking brake: 22.0 Nm

Table for blocking brake with 14 and 20 Nm

| Size | Dim. | | Vers. 4 | |
|-----------|------|-----|---------|-----|
| | L | B | L | B |
| MAC 093 A | 384 | 119 | 484 | 119 |
| MAC 093 B | 425 | 160 | 525 | 160 |
| MAC 093 C | 484 | 219 | 584 | 219 |

Vers. 2 = Motor with tachofeedback
Vers. 4 = Motor with tachofeedback and mounted encoder

4 Output shaft

- plain shaft (recommended type)
- with keyway per DIN 6885 sh. 1, 8/68 edition
(Note! balanced with entire key.)

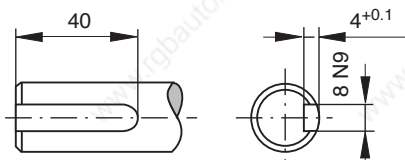

Matching key: DIN 6885-A 8 x 7 x 50
Must be ordered separately.

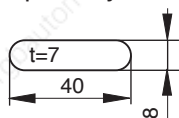

5 Special centering diameter

- Ø130 j6

MB093-1/3

Fig 6.21: Dimensional data - MAC 093 - available options - (axial cooling)

6.7. Available Options

| Type code fields | | Example: | MAC 093 A-0-LS-4 - C/110-A-0/WI 520LV/S000 | | | | | | | |
|--|--|----------|--|-----------------|---|---|---|---|---|---|
| 1. Motor for analogue drives | | MAC | | | | | | | | |
| 2. Motor size | | 093 | | | | | | | | |
| 3. Motor length | | A, B, C | | | | | | | | |
| 4. Type of cooling: | | | | | | | | | | |
| natural convection | | | | | | | | | | |
| surface cooling | | | | | | | | | | |
| axial | | | | | | | | | | |
| radial | | | | | | | | | | |
| blower right | | | | | | | | | | |
| blower below | | | | | | | | | | |
| blower left | | | | | | | | | | |
| AC 230 V | | | | | | | | | | |
| AC 115 V | | | | | | | | | | |
| AC 230 V | | | | | | | | | | |
| AC 115 V | | | | | | | | | | |
| AC 230 V | | | | | | | | | | |
| AC 115 V | | | | | | | | | | |
| 0 | | | 1 ¹⁾ | 2 ¹⁾ | 6 | A | 7 | B | 8 | C |
| 5. Type of windings | | | | | | | | | | |
| Nominal rpm | | | | | | | | | | |
| 2000 min ⁻¹ | | | | | | | | | | |
| 3000 min ⁻¹ | | | | | | | | | | |
| 4000 min ⁻¹ | | | | | | | | | | |
| 6000 min ⁻¹ | | | | | | | | | | |
| 6. Motor feedback | | | | | | | | | | |
| Motor type | | | | | | | | | | |
| with tachofeedback | | | | | | | | | | |
| with tachofeedback and second shaft end | | | | | | | | | | |
| with tachofeedback and mounted incremental or absolute encoder | | | | | | | | | | |
| Tacho voltage | | | | | | | | | | |
| set to nominal motor speed | | | | | | | | | | |
| (nominal rpm > 3000 min ⁻¹) | | | | | | | | | | |
| : 1.5 V/1000 min ⁻¹) | | | | | | | | | | |
| (nominal rpm ≤ 3000 min ⁻¹) | | | | | | | | | | |
| : 3 V/1000 min ⁻¹) | | | | | | | | | | |
| 1.5 V/1000 min ⁻¹) | | | | | | | | | | |
| Tacho type | | | | | | | | | | |
| Standard | | | | | | | | | | |
| increased smooth run quality | | | | | | | | | | |
| 7. Centering diameter | | | | | | | | | | |
| for design B05 and B14 | | | | | | | | | | |
| for design B05 and B14 | | | | | | | | | | |
| 8. Power connection | | | | | | | | | | |
| connector to side A | | | | | | | | | | |
| connector to side B | | | | | | | | | | |
| connector to right (looking onto output shaft) | | | | | | | | | | |
| connector to left (looking onto output shaft) | | | | | | | | | | |
| 9. Blocking brake | | | | | | | | | | |
| without blocking brake | | | | | | | | | | |
| with standard blocking brake (6.5 Nm) | | | | | | | | | | |
| with heavy-duty blocking brake (14 Nm) | | | | | | | | | | |
| with extra heavy-duty blocking brake (22 Nm) | | | | | | | | | | |
| 10. Type | | | | | | | | | | |
| Incremental encoder with standard mounting | | | | | | | | | | |
| Incremental encoder with shock-damped mounting | | | | | | | | | | |
| Absolute encoder | | | | | | | | | | |
| 11. Encoder code | | | | | | | | | | |
| For available types, see section 2.4 "Motor feedback" | | | | | | | | | | |
| 12. Special types | | | | | | | | | | |
| Fixed and documented by INDRAMAT with special number (see Drawing no.: 106-0105-4301-XX) | | | | | | | | | | |
| Does not apply to standard motors. | | | | | | | | | | |

1) For type 3 motors (with 2nd shaft end and tachofeedback). Not available with axial surface cooling.

2) Type code fields 10 and 11 do not apply to motor types 2 and 3.

TLMAC093

Fig 6.22: Type codes - MAC 093

6.8. Special Options

| | |
|-----------------------------------|------|
| Specification of Option | S005 |
| with keyway per DIN 6885, sheet 1 | X |

Fig 6.23: Special options with a MAC 093

Empty page

7. MAC 112

7.1. Technical Data

| Designation | Symbol | Unit | Motor type MAC ... | | | |
|---|-------------------|-------------------|---------------------------|---------------------------|---------------------------|---------------------------|
| | | | 112 A - - - Z • | 112 B - - - P • | 112 C - - - K • | 112 D - - - H • |
| Nominal motor speed ¹⁾ | n | min ⁻¹ | 1500 | 1500 | 1500 | 1500 |
| Continuous torque at standstill ²⁾ | M _{dN} | Nm | 10.7 (13.0) ⁵⁾ | 18.2 (29) ⁵⁾ | 28.0 (44.0) ⁵⁾ | 38.0 (57.0) ⁵⁾ |
| Continuous current at standstill | I _{dN} | A | 14.5 (17.2) ⁵⁾ | 21.0 (33.0) ⁵⁾ | 31.0 (49.0) ⁵⁾ | 42.0 (63) ⁵⁾ |
| Rotor moment of inertia ³⁾ | J _M | kgm ² | 61 x 10 ⁻⁴ | 120 x 10 ⁻⁴ | 170 x 10 ⁻⁴ | 230 x 10 ⁻⁴ |
| Torque constant at 20 °C | K _m | Nm/A | 0.820 | 0.910 | 1.000 | 1.010 |
| Windings resistance at 20 °C | R _A | Ohm | 0.990 | 0.450 | 0.270 | 0.176 |
| Windings inductance | L _A | mH | 10.0 | 6.3 | 4.5 | 3.2 |
| Maximum peak of pulse current | I _{peak} | A | 54 | 97 | 141 | 195 |
| Thermal time constant | T _{th} | min | 100 (75) ⁵⁾ | 90 (60) ⁵⁾ | 100 (75) ⁵⁾ | 120 (90) ⁵⁾ |
| Mass ⁴⁾ | m _M | kg | 25 | 36 | 48 | 59 |
| | | | 112 A - - - V • | 112 B - - - L • | 112 C - - - H • | 112 D - - - F • |
| Nominal motor speed ¹⁾ | n | min ⁻¹ | 2000 | 2000 | 2000 | 2000 |
| Continuous torque at standstill ²⁾ | M _{dN} | Nm | 10.5 (13.0) ⁵⁾ | 17.5 (29) ⁵⁾ | 27.0 (44.0) ⁵⁾ | 38.0 (57.0) ⁵⁾ |
| Continuous current at standstill | I _{dN} | A | 18.5 (22.9) ⁵⁾ | 26.3 (43.5) ⁵⁾ | 41.0 (67.0) ⁵⁾ | 56.0 (83) ⁵⁾ |
| Rotor moment of inertia ³⁾ | J _M | kgm ² | 61 x 10 ⁻⁴ | 120 x 10 ⁻⁴ | 170 x 10 ⁻⁴ | 230 x 10 ⁻⁴ |
| Torque constant at 20 °C | K _m | Nm/A | 0.630 | 0.740 | 0.730 | 0.760 |
| Windings resistance at 20 °C | R _A | Ohm | 0.650 | 0.260 | 0.150 | 0.110 |
| Windings inductance | L _A | mH | 6.0 | 3.5 | 2.5 | 1.8 |
| Maximum peak of pulse current | I _{peak} | A | 71 | 130 | 195 | 260 |
| Thermal time constant | T _{th} | min | 100 (75) ⁵⁾ | 90 (60) ⁵⁾ | 100 (75) ⁵⁾ | 120 (90) ⁵⁾ |
| Mass ⁴⁾ | m _M | kg | 25 | 36 | 48 | 59 |
| | | | 112 A - - - L • | 112 B - - - G • | 112 C - - - E • | 112 D - - - E • |
| Nominal motor speed ¹⁾ | n | min ⁻¹ | 3000 | 3000 | 3000 | 3000 |
| Continuous torque at standstill ²⁾ | M _{dN} | Nm | 9.8 (13.0) ⁵⁾ | 16.0 (29) ⁵⁾ | 24.0 (44.0) ⁵⁾ | 35.0 (57.0) ⁵⁾ |
| Continuous current at standstill | I _{dN} | A | 31.0 (41.3) ⁵⁾ | 41.0 (75.0) ⁵⁾ | 57.0 (104) ⁵⁾ | 63.0 (102) ⁵⁾ |
| Rotor moment of inertia ³⁾ | J _M | kgm ² | 61 x 10 ⁻⁴ | 120 x 10 ⁻⁴ | 170 x 10 ⁻⁴ | 230 x 10 ⁻⁴ |
| Torque constant at 20 °C | K _m | Nm/A | 0.350 | 0.430 | 0.470 | 0.620 |
| Windings resistance at 20 °C | R _A | Ohm | 0.180 | 0.090 | 0.060 | 0.070 |
| Windings inductance | L _A | mH | 1.9 | 1.2 | 1.0 | 1.3 |
| Maximum peak of pulse current | I _{peak} | A | 130 | 223 | 312 | 312 |
| Thermal time constant | T _{th} | min | 100 (75) ⁵⁾ | 90 (60) ⁵⁾ | 100 (75) ⁵⁾ | 120 (90) ⁵⁾ |
| Mass ⁴⁾ | m _M | kg | 25 | 36 | 48 | 59 |
| | | | | | 112 C - - - C • | |
| Nominal motor speed ¹⁾ | n | min ⁻¹ | | | 5000 | |
| Continuous torque at standstill ²⁾ | M _{dN} | Nm | | | 27.0 | |
| Continuous current at standstill | I _{dN} | A | | | 87.5 | |
| Rotor moment of inertia ³⁾ | J _M | kgm ² | | | 170 x 10 ⁻⁴ | |
| Torque constant at 20 °C | K _m | Nm/A | | | 0.330 | |
| Windings resistance at 20 °C | R _A | Ohm | | | 0.030 | |
| Windings inductance | L _A | mH | | | 0.5 | |
| Maximum peak of pulse current | I _{peak} | A | | | 400 | |
| Thermal time constant | T _{th} | min | | | 100 | |
| Mass ⁴⁾ | m _M | kg | | | 48 | |

1) The usable motor speed is determined by the drive used.
Only those usable speeds n_{max} found in the selection lists of the motor-drive combinations are binding.

2) With 60K overtemperature at the motor housing.
Continuous torque can be limited by the drive. See selection data.

3) With tacho-generator, without holding brake

4) With tacho-generator, without holding brake, without blower.

5) Parenthetical values apply to versions with surface cooling.

Fig 7.1: Type-dependent motor data

| Designation | Symbol | Unit | Data | | |
|--|----------|-------------------------------|----------------------------|------------------|--------------------------------|
| Permissible ambient temperature | T_{um} | °C | 0 ... + 45 | | |
| Permissible storage and transport temperature | T_L | °C | -20 ... +80 | | |
| Maximum installation elevation | | m | 1000 m. above sea level | | |
| Protection category | | | IP 65 | | |
| Insulation classification | | | F | | |
| Housing coat | | | Black prime coat (RAL9005) | | |
| Voltage constant of the tachogenerator ¹⁾ | C_w | Vs/rad V/min ⁻¹ | 0.0143 1.5/1000 | 0.0286 3/1000 | 0.0572 6/1000 ²⁾ |

¹⁾ Tachovoltage can be selected application-related.
²⁾ If 6 V/1000 min⁻¹ tachometer is used, then usable speed is limited to 1600 min⁻¹.

Fig 7.2: General data MAC 112

| Designation | Symbol | Unit | Data holding brake | | |
|---------------------|--------|------------------|----------------------|---|--------------------------------|
| | | | Standard | heavy-duty ¹⁾ electrically released | extra heavy-duty ¹⁾ |
| Principle of action | | | | | |
| Holding torque | M_H | Nm | | 40 | |
| Nominal voltage | U_N | V | 14 | DC 24 ± 10% | 60 |
| Nominal current | I_N | A | 0.75 | 1.35 | 1.35 |
| Moment of inertia | J_B | kgm ² | 3.6×10^{-4} | 32×10^{-4} | 32×10^{-4} |
| Release delay | t_L | ms | 70 | 150 | 150 |
| Clamping delay | t_K | ms | 30 | 30 | 30 |
| Mass | m_B | kg | 1.1 | 3.5 | 3.5 |

¹⁾ Not available with MAC 112A .

Fig 7.3: Technical data - holding brake

| Designation | Symbol | Unit | Axial cooling | Radial cooling |
|----------------------------------|--------|------|-----------------------------|-----------------------------|
| Power consumption | S_N | VA | 40/42 | 40/42 |
| Nominal voltage | U_N | V | AC 230 or 115 ¹⁾ | AC 230 or 115 ¹⁾ |
| Frequency | f | Hz | 50/60 | 50/60 |
| Mass | m_L | kg | approx.. 3.3 ²⁾ | approx.. 3.2 ²⁾ |
| Protection category blower unit | | | IP 24 | IP 24 |
| Protection category blower motor | | | IP 44 | IP 44 |

¹⁾ 115 V special design
²⁾ Blower shroud for motor with tacho feedback.

Fig 7.4: Technical data - surface cooling

7.2. Torque-Speed Characteristics

MAC 112 A - - - Z •
1500 min⁻¹

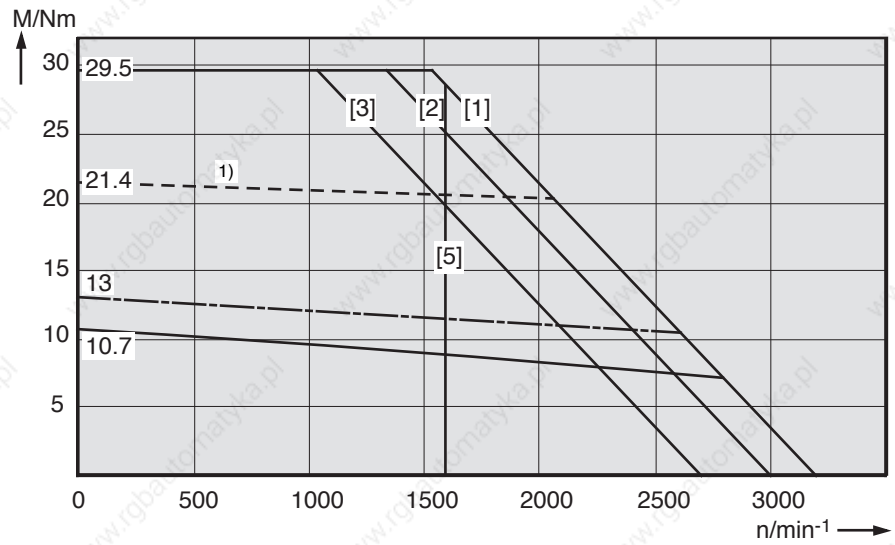

MAC 112 A - - - V •
2000 min⁻¹

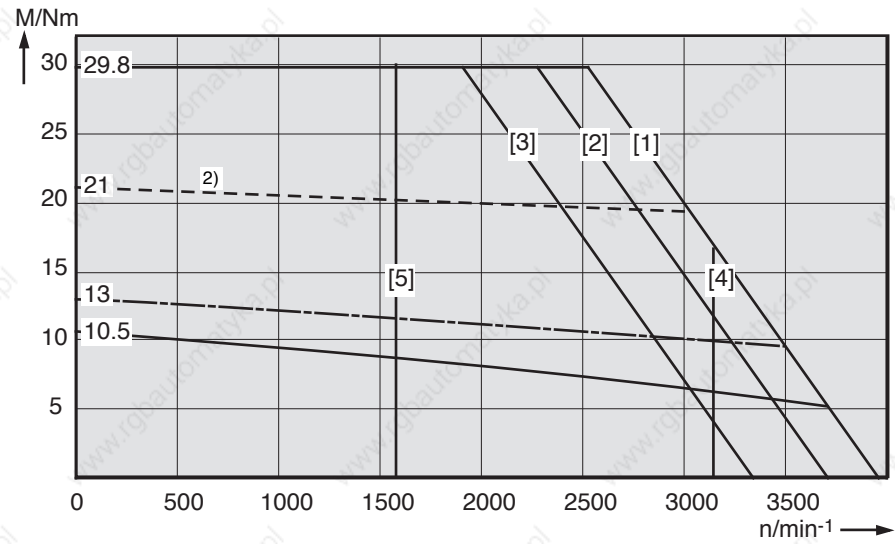

MAC 112 A - - - L •
3000 min⁻¹

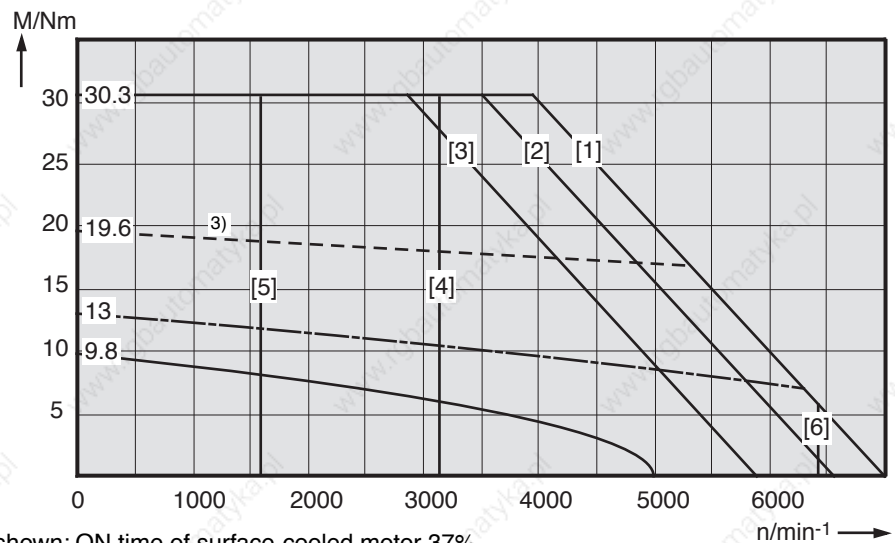

- 1) shown: ON time of surface-cooled motor 37%
- 2) shown: ON time of surface-cooled motor 38%
- 3) shown: ON time of surface-cooled motor 44%

Fig 7.5: Torque-speed characteristics MAC 112

MAC 112 B - - - P •
1500 min⁻¹

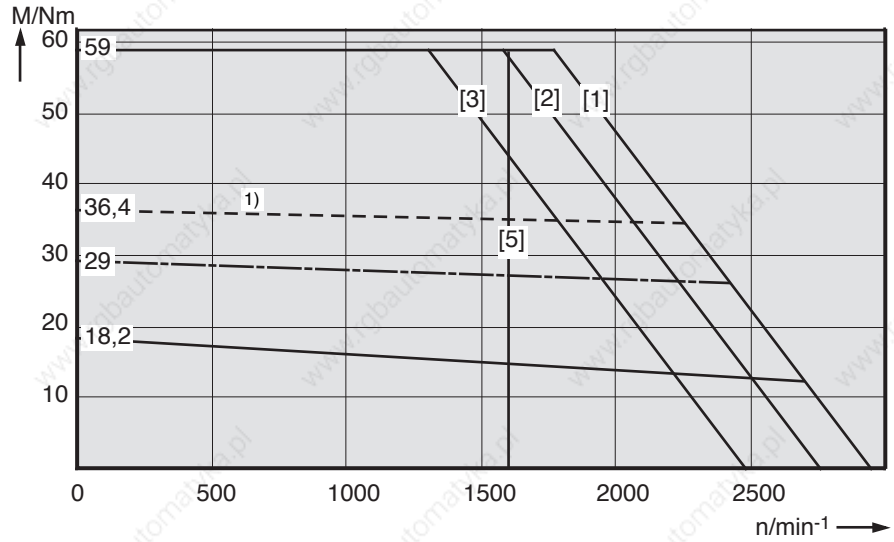

MAC 112 B - - - L •
2000 min⁻¹

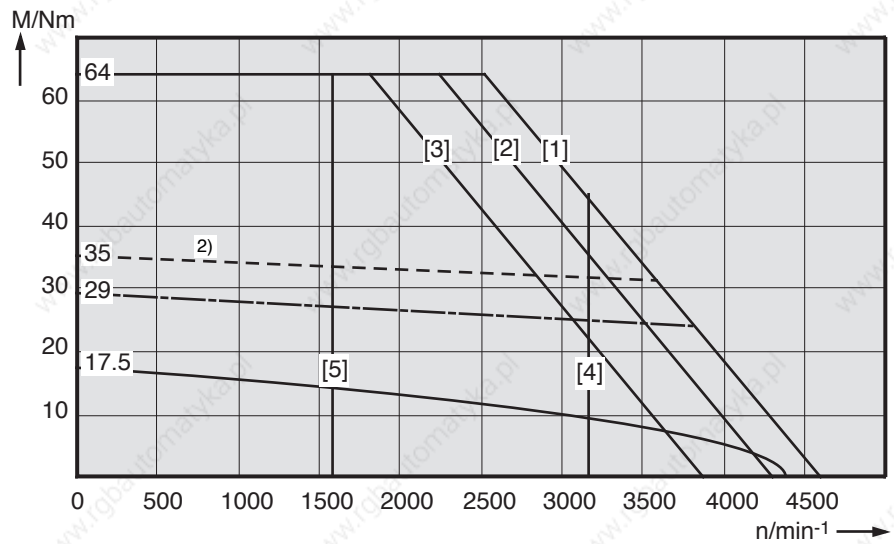

MAC 112 B - - - G •
3000 min⁻¹

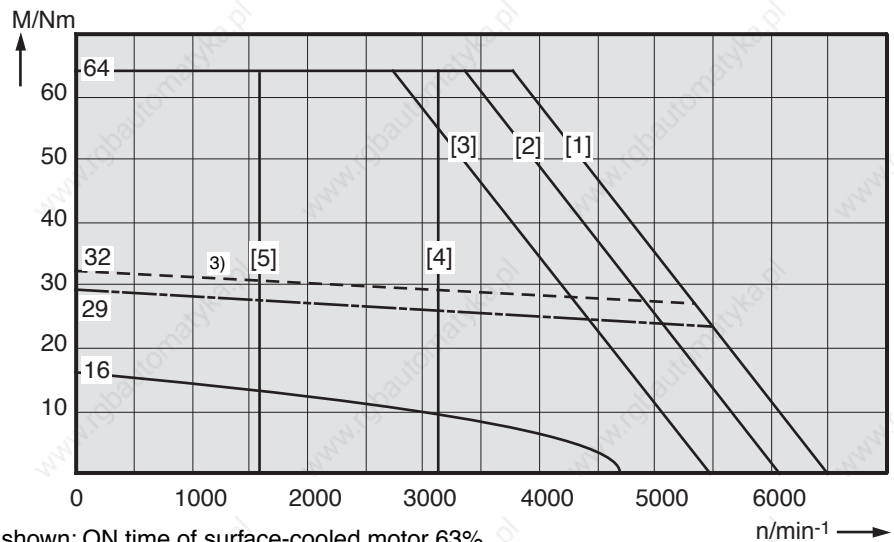

- 1) shown: ON time of surface-cooled motor 63%
- 2) shown: ON time of surface-cooled motor 69%
- 3) shown: ON time of surface-cooled motor 82%

Fig 7.6: Torque-speed characteristics MAC 112

MAC 112 C - - - K •
1500 min⁻¹

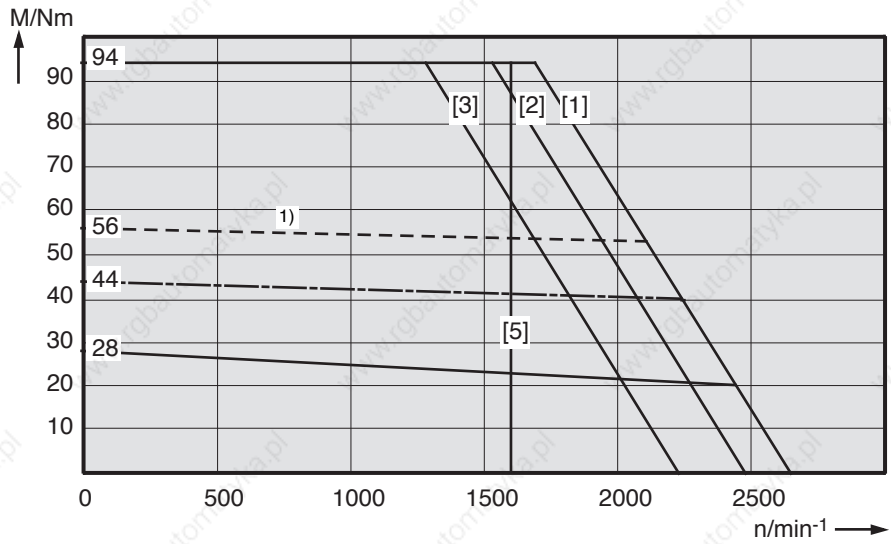

MAC 112 C - - - H •
2000 min⁻¹

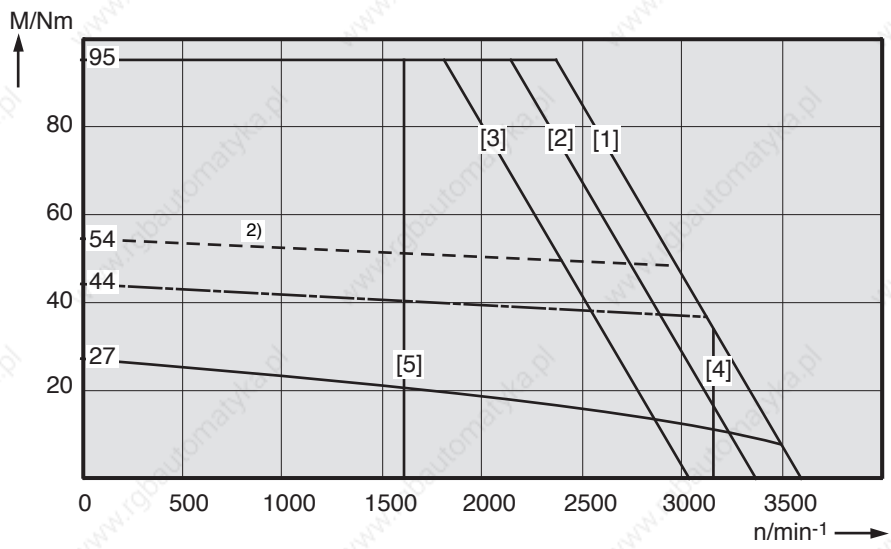

1) shown: ON time of surface-cooled motor 62%
2) shown: ON time of surface-cooled motor 66%

Fig 7.7: Torque-speed characteristics MAC 112

MAC 112 C - - - E •
3000 min⁻¹

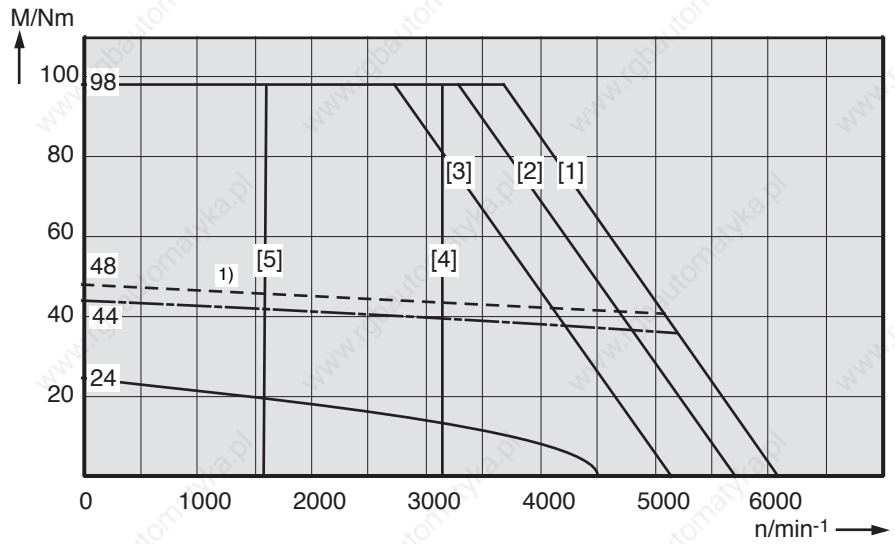

MAC 112 C - - - C •
5000 min⁻¹

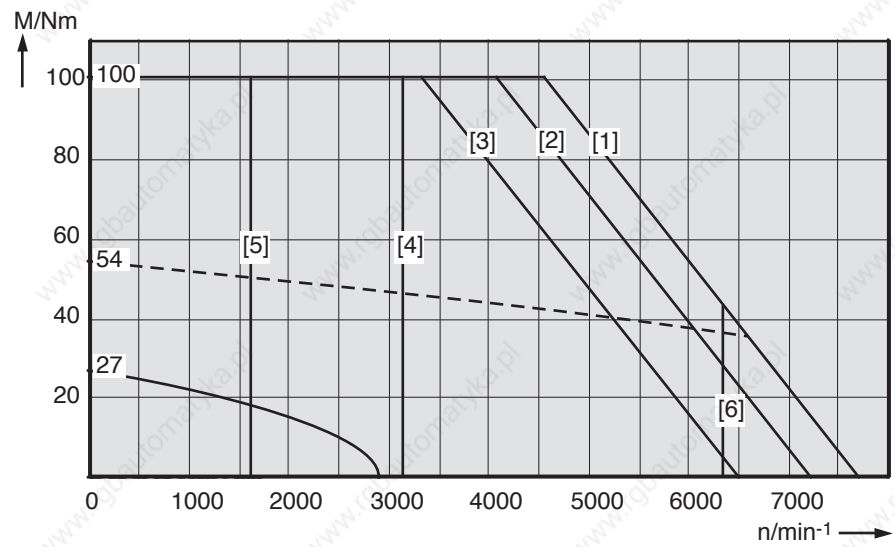

1) shown: ON time of surface-cooled motor 87%

Fig 7.8: Torque-speed characteristics MAC 112

MAC 112 D - - - H •
1500 min⁻¹

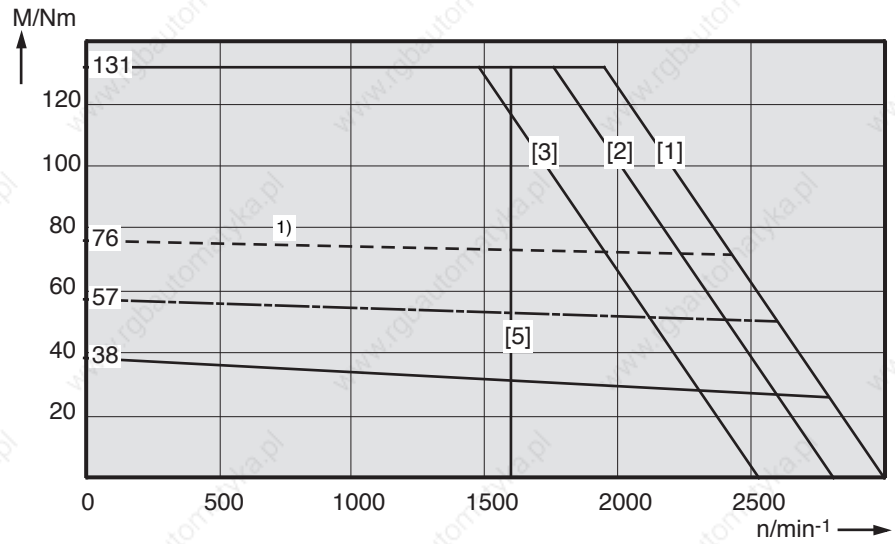

MAC 112 D - - - F •
2000 min⁻¹

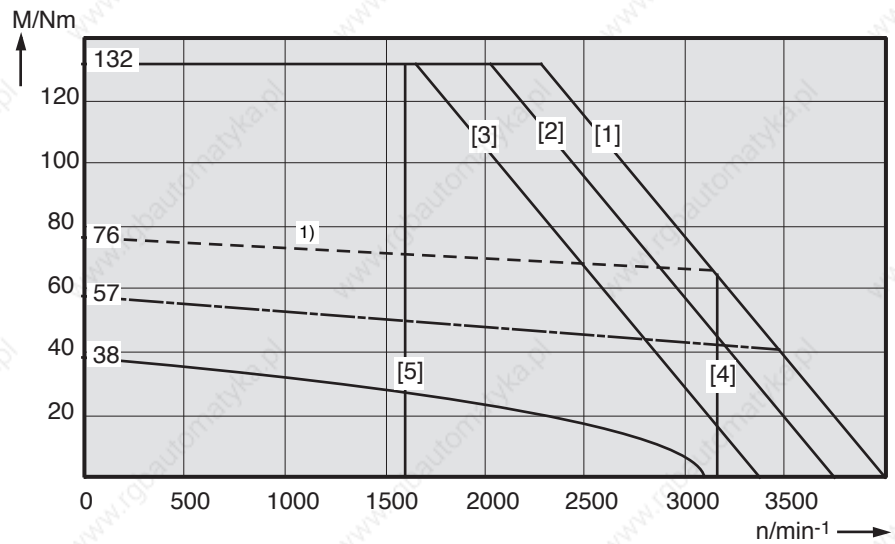

MAC 112 D - - - E •
3000 min⁻¹

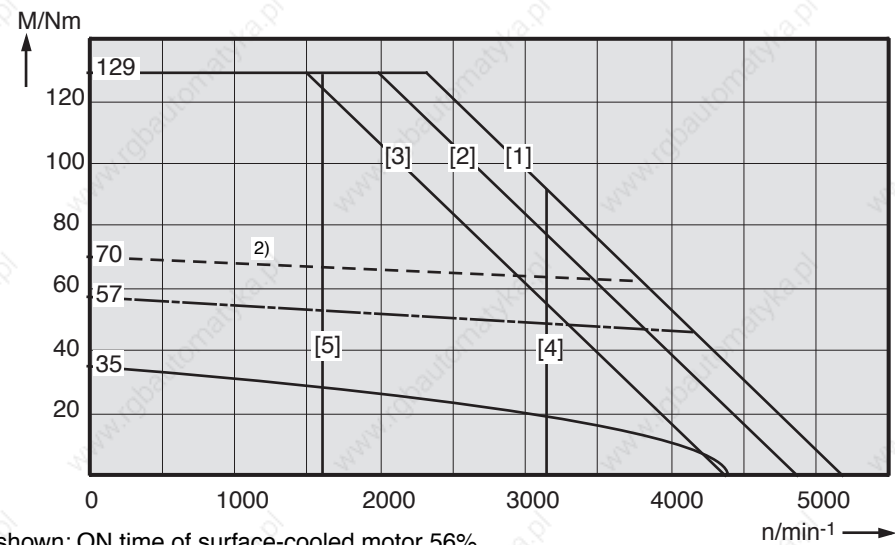

1) shown: ON time of surface-cooled motor 56%
2) shown: ON time of surface-cooled motor 66%

Fig 7.9: Torque-speed characteristics MAC 112

7.3. Shaft load capacity

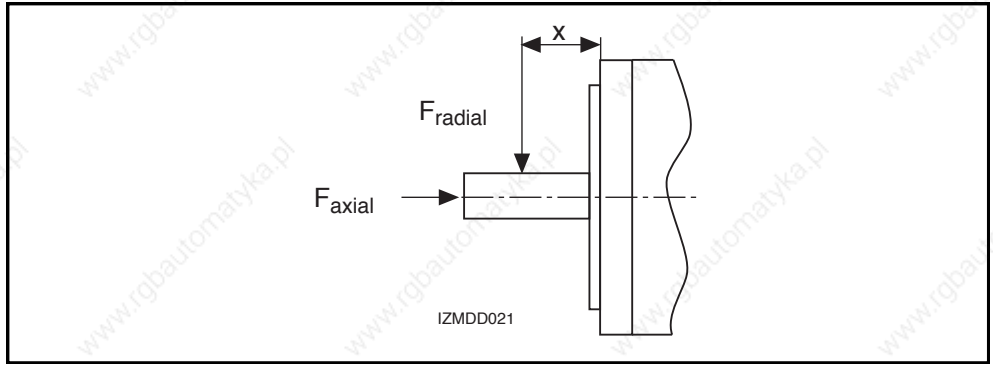

Fig 7.10: Shaft load

Permissible radial force
 F_{radial}

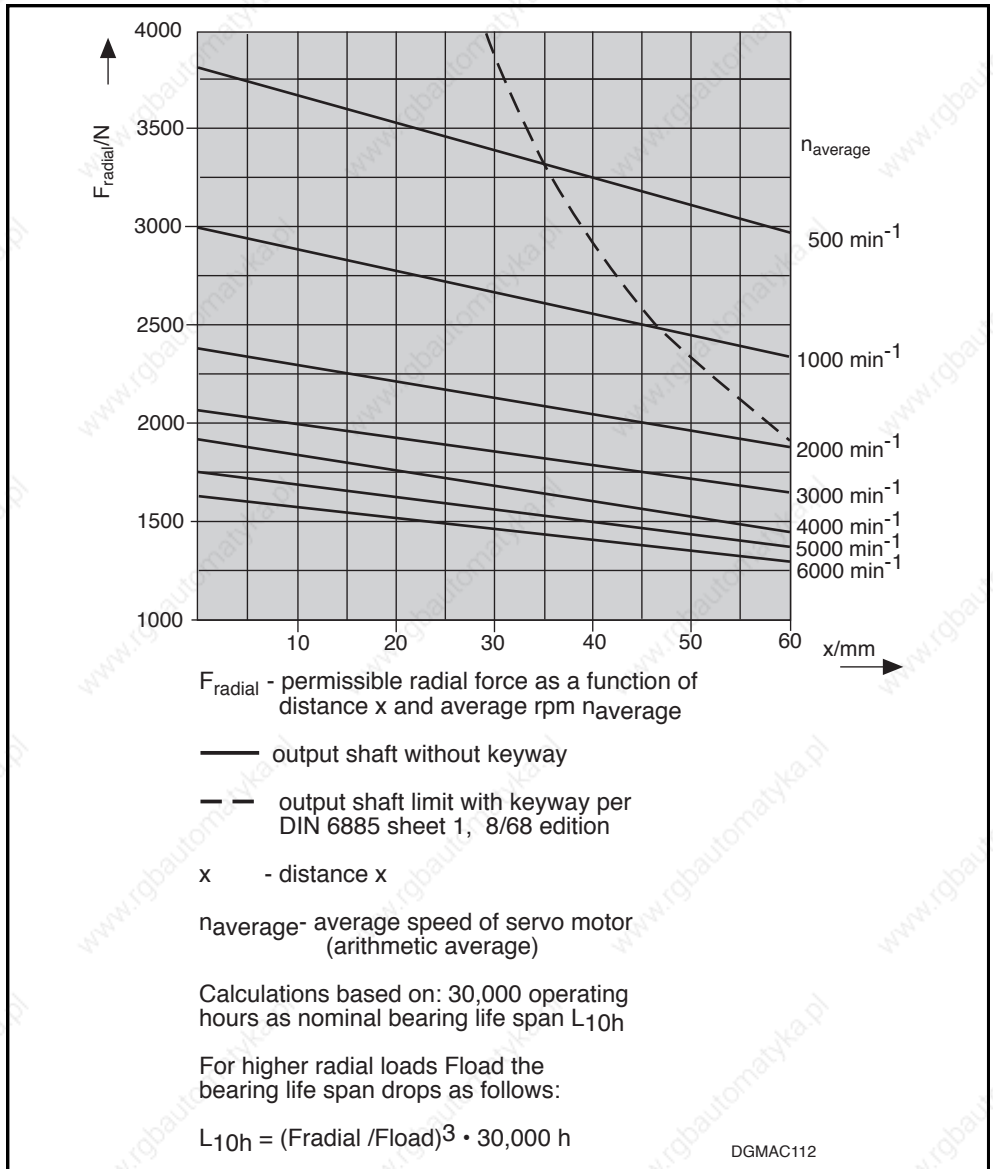

Fig 7.11: Permissible radial force

Permissible axial force
 F_{axial}

$$F_{axial} = 0.35 \cdot F_{radial}$$

F_{axial} - Permissible axial force

F_{radial} - Permissible radial force

7.4. Dimensional data - natural convection

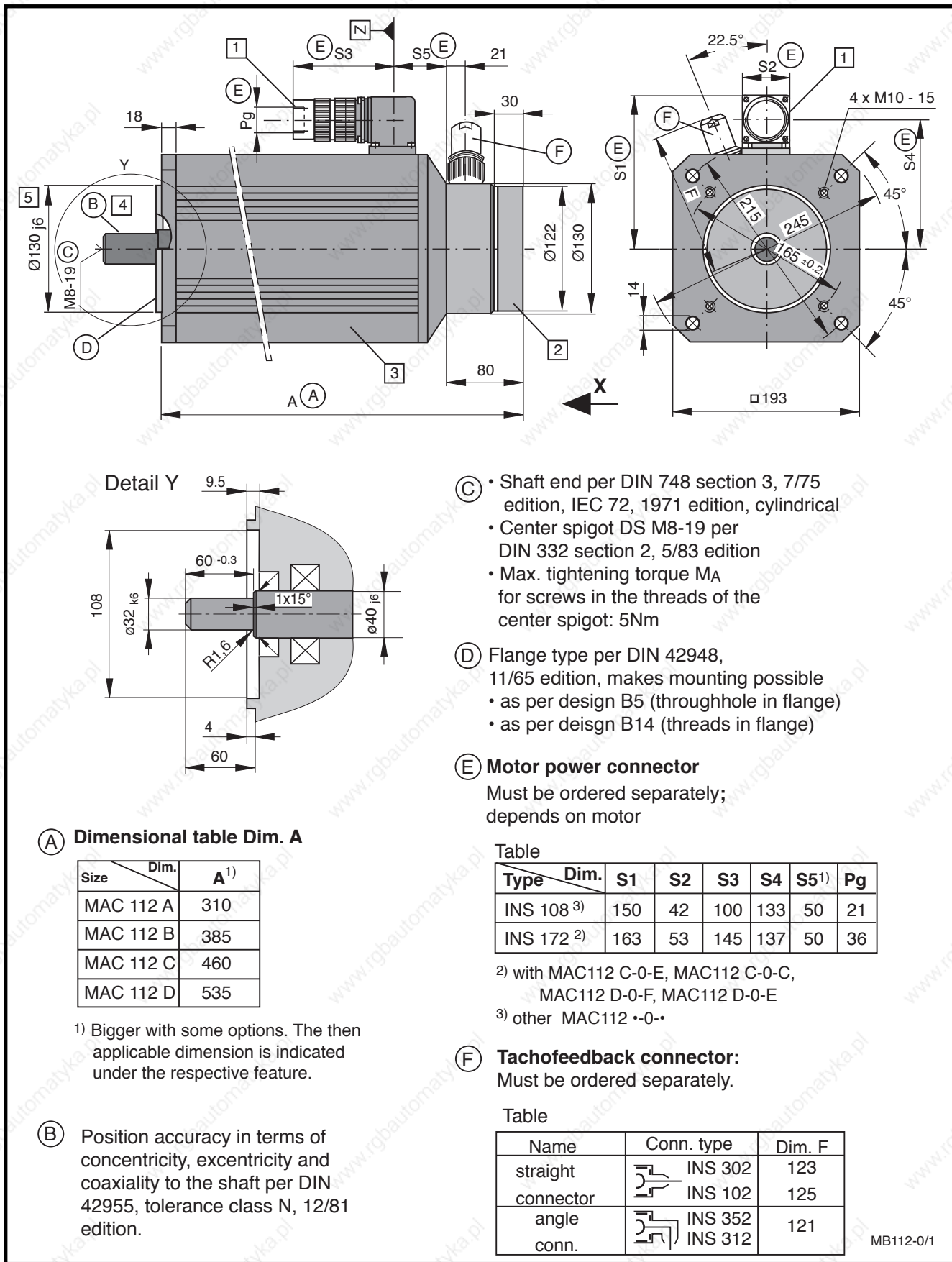

Fig 7.12: Dimensional data - MAC 112 (natural convection)

Available options

1 Power connection

The output direction of the electrical power connector is selected at the time the order is placed. Possible output directions are:

- to side A
- to side B
- to the right
- to the left

The drawing depicts side A as output direction. The dimensions of any other direction are obtained by a virtual turning of the connector housing around the Z axis.

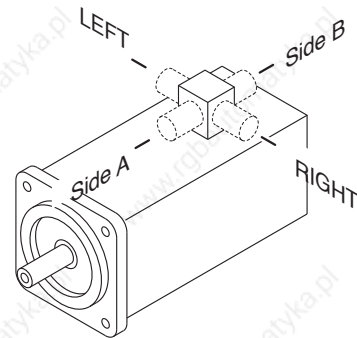

2 Motor version

- Tachofeedback and second shaft end

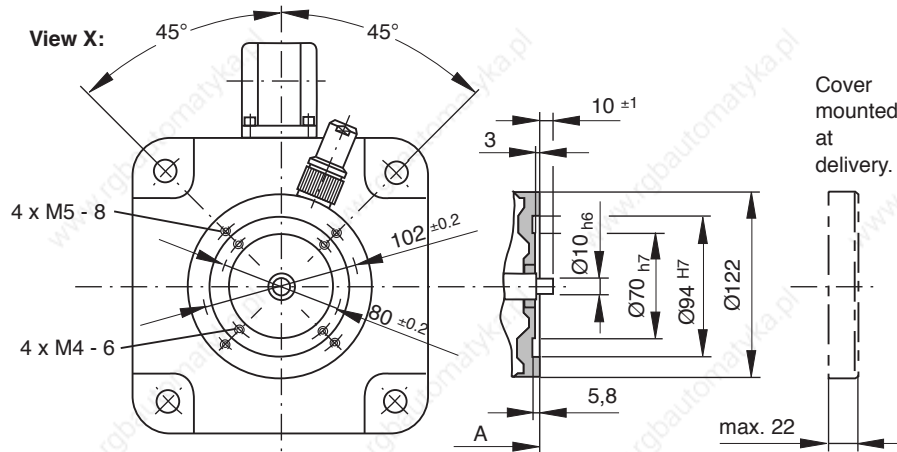

- Tachofeedback and mounted incremental encoder

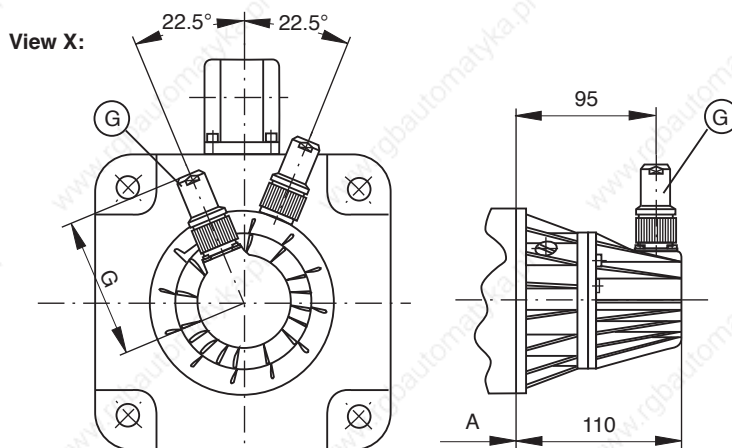

G Incremental encoder connector

Must be ordered separately.

| Name | Conn. type | Dim. G |
|----------------|--------------------|--------|
| straight conn. | INS 301 | 88 |
| | INS 101 | 90 |
| angle conn. | INS 351 INS 311 | 86 |

- Tachofeedback and mounted absolute encoder (see following page)

MB112-0/2

Fig 7.13: Dimensional data - MAC 112 - available options - (natural convection)

Available options

- Tachofeedback and mounted absolute encoder

View X:

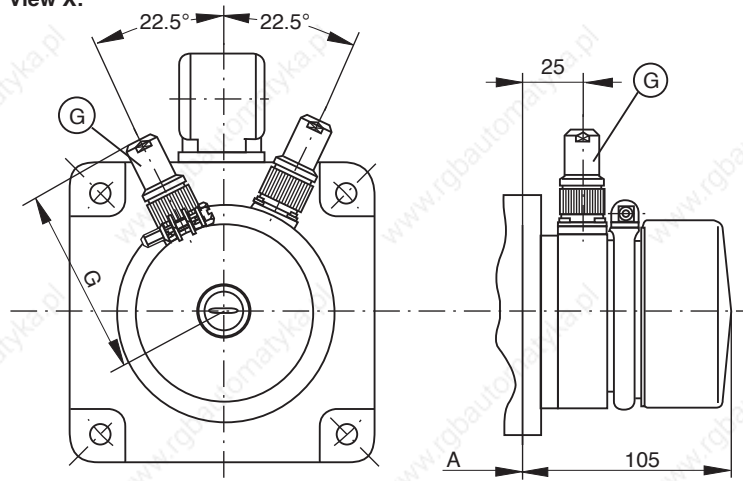

G Absolute encoder conn.
Must be ordered separately.

| Name | Conn. type | Dim. G |
|----------------|------------|--------|
| straight conn. | INS 326 | 104 |
| | INS 92 | 106 |
| angle conn. | INS 322 | 102 |

3 Blocking brake

- without blocking brake
Dim. A and S5 retained
- Standard blocking brake: 14 Nm
Dim. A and S5 retained
- heavy-duty blocking brake: 40 Nm
(not available with MAC 112 A ...)
- extra heavy-duty blocking brake: 60 Nm
(not available with MAC 112 A ...)

Table for blocking brake with 40 and 60 Nm

| Size | Dim. | A | S5 |
|-----------|------|-----|----|
| MAC 112 B | | 435 | 98 |
| MAC 112 C | | 510 | 98 |
| MAC 112 D | | 585 | 98 |

4 Output shaft

- plain shaft (recommended type)
- with keyway per DIN 6885 sh. 1, 8/68 edition
(Note! balanced with entire key.)

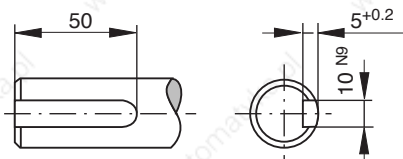

Matching key: DIN 6885-A 10 x 8 x 40
Must be ordered separately.

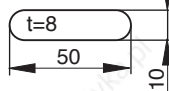

5 Special centering diameter

- $\varnothing 180 \text{ j6}$

MB112-0/3

Fig 7.14: Dimensional data - MAC 112 - available options - (natural convection)

7.5. Dimensional data - radial cooling

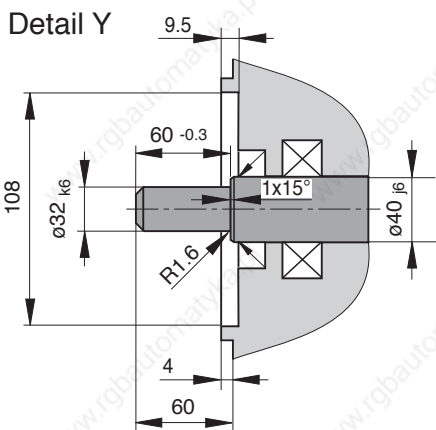
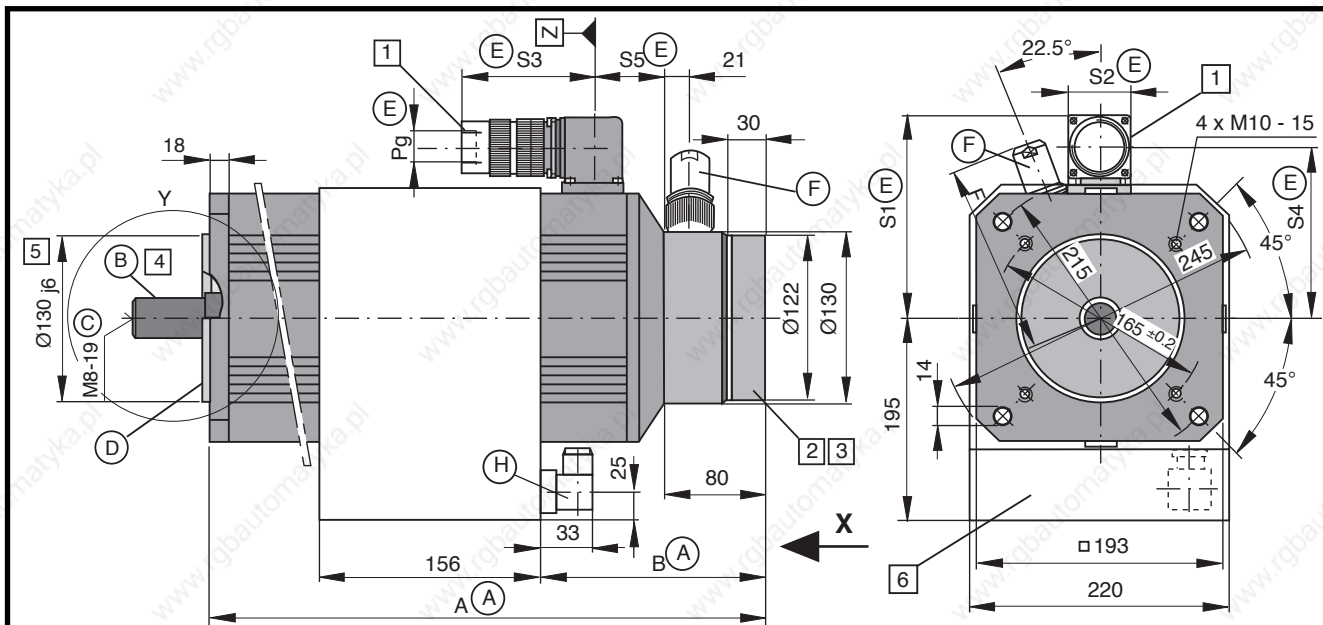

- (C) • Shaft end per DIN 748 section 3, 7/75 edition, IEC 72, 1971 edition, cylindrical
- Center spigot DS M8-19 per DIN 332 section 2, 5/83 edition
- Max. tightening torque MA for screws in the threads of the center spigot: 5 Nm
- (D) Flange type per DIN 42948, 11/65 edition, makes mounting possible
 - as per design B5 (throughhole in flange)
 - as per design B14 (threads in flange)
- (E) **Motor power connector**
Must be ordered separately.

(A) Dimensional table Dim. A and B

| Size | Dim. | A ¹⁾ | B ¹⁾ |
|-----------|------|-----------------|-----------------|
| MAC 112 A | | 310 | 110 |
| MAC 112 B | | 385 | 110 |
| MAC 112 C | | 460 | 205 |
| MAC 112 D | | 535 | 205 |

¹⁾ Bigger with some options. The then applicable dimension is indicated under the respective feature.

(B) Position accuracy in terms of concentricity, excentricity and coaxiality to the shaft per DIN 42955, tolerance class N, 12/81 edition.

Table

| Type | Dim. | S1 | S2 | S3 | S4 | S5 ¹⁾ | Pg |
|-----------------------|------|-----|----|-----|-----|------------------|----|
| INS 108 ²⁾ | | 150 | 42 | 100 | 133 | 50 | 21 |
| INS 172 ³⁾ | | 163 | 53 | 145 | 137 | 50 | 36 |

²⁾ with MAC112 A--Z, MAC112 A--V, MAC112 A--C, MAC112 B--P, MAC112 B--L

³⁾ other MAC112

(F) **Tachofeedback connector:**
Must be ordered separately.

Table

| Name | Conn. type | Dim. F |
|--------------------|--------------------|--------|
| straight connector | INS 302 | 123 |
| angle conn. | INS 352 INS 312 | 121 |

(H) **Blower connector: INS 195**
Must be ordered separately.

MB112-1rad/1

Fig 7.15: Dimensional data - MAC 112 (radial cooling)

Available options

1 Power connection

The output direction of the electrical power connector is selected at the time the order is placed. Possible output directions are:

- to side A
- to side B
- to the right
- to the left

The drawing depicts side A as output direction. The dimensions of any other direction are obtained by a virtual turning of the connector housing around the Z axis.

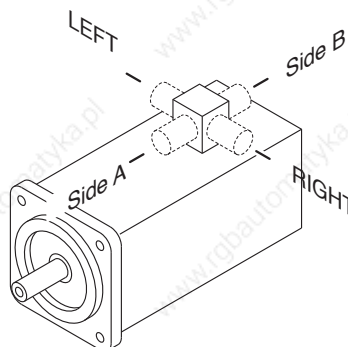

2 Motor version

- Tachofeedback and second shaft end

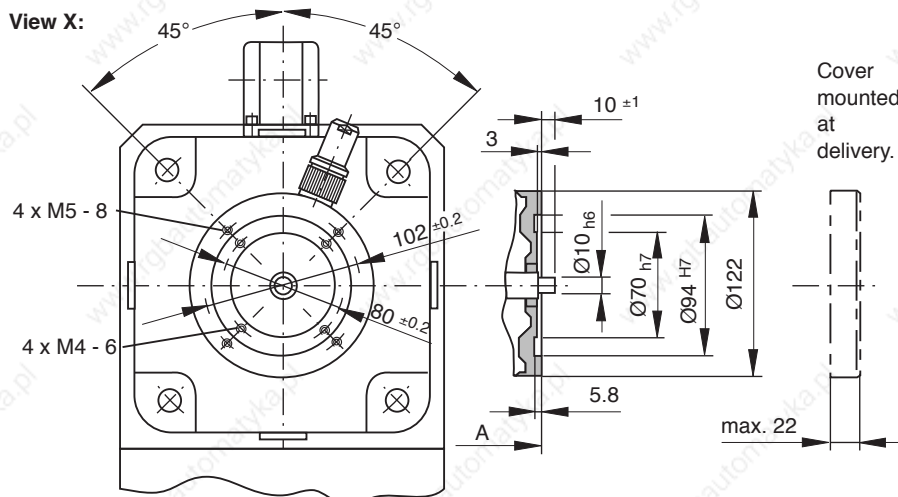

- Tachofeedback and mounted incremental encoder

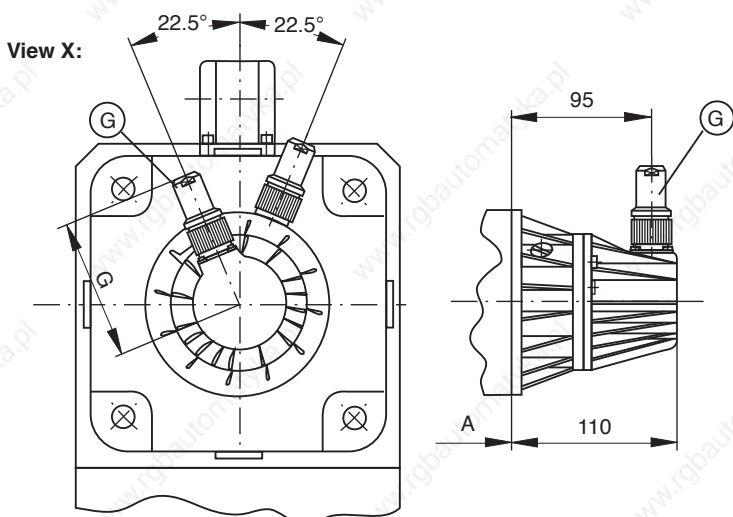

G Incremental encoder connector

Must be ordered separately.

| Name | Conn. type | Dim. G |
|----------------|--------------------|--------|
| straight conn. | INS 301 | 88 |
| | INS 101 | 90 |
| angle conn. | INS 351 INS 311 | 86 |

- Tachofeedback and mounted absolute encoder (see following page)

MB112-1rad/2

Fig 7.16: Dimensional data - MAC 112 - available options - (radial cooling)

Available options

- Tachofeedback and mounted absolute encoder

View X:

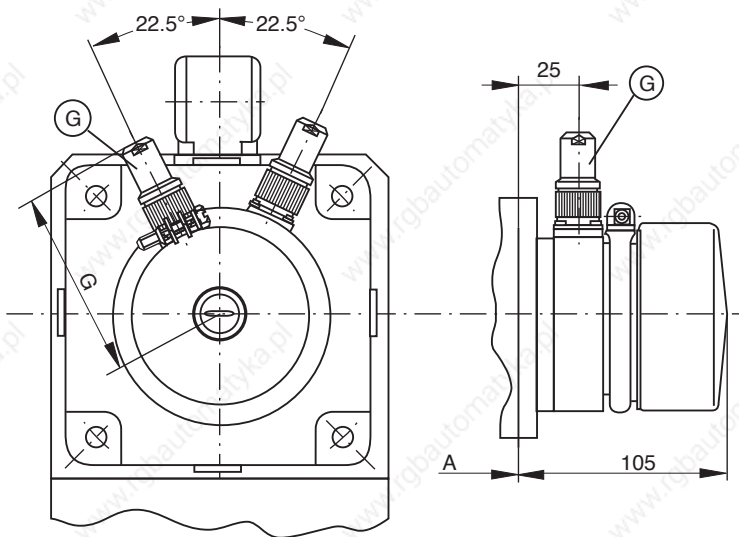

G Absolute encoder conn.
Must be ordered separately.

| Name | Conn. type | Dim. G |
|----------------|------------|--------|
| straight conn. | INS 326 | 104 |
| | INS 92 | 106 |
| angle conn. | INS 322 | 102 |

3 Blocking brake

- without blocking brake
Dim. A, B and S5 retained
- Standard blocking brake: 14 Nm
Dim. A, B and S5 retained
- heavy-duty blocking brake: 40 Nm
(not available with MAC 112 A ...)
- extra heavy-duty blocking brake: 60 Nm
(not available with MAC 112 A ...)

Table for blocking brake with 40 and 60 Nm

| Size \ Dim. | A | S5 | B |
|-------------|-----|----|-----|
| MAC 112 B | 435 | 98 | 160 |
| MAC 112 C | 510 | 98 | 255 |
| MAC 112 D | 585 | 98 | 255 |

4 Output shaft

- plain shaft (recommended type)
- with keyway per DIN 6885 sh. 1, 8/68 edition
(Note! balanced with entire key.)

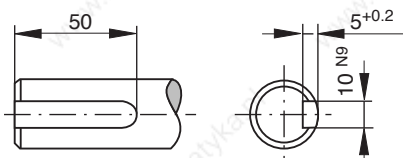

Matching key: DIN 6885-A 10 x 8 x 50
Must be ordered separately.

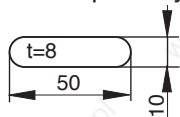

5 Special centering diameter

- $\varnothing 180 j6$

6 Blower arrangement

Looking towards motor shaft.

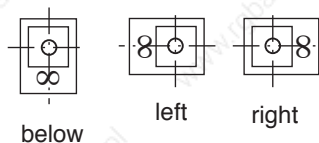

MB112-1rad/3

Fig 7.17: Dimensional data - MAC 112 - available options - (radial cooling)

7.6. Dimensional data - axial cooling

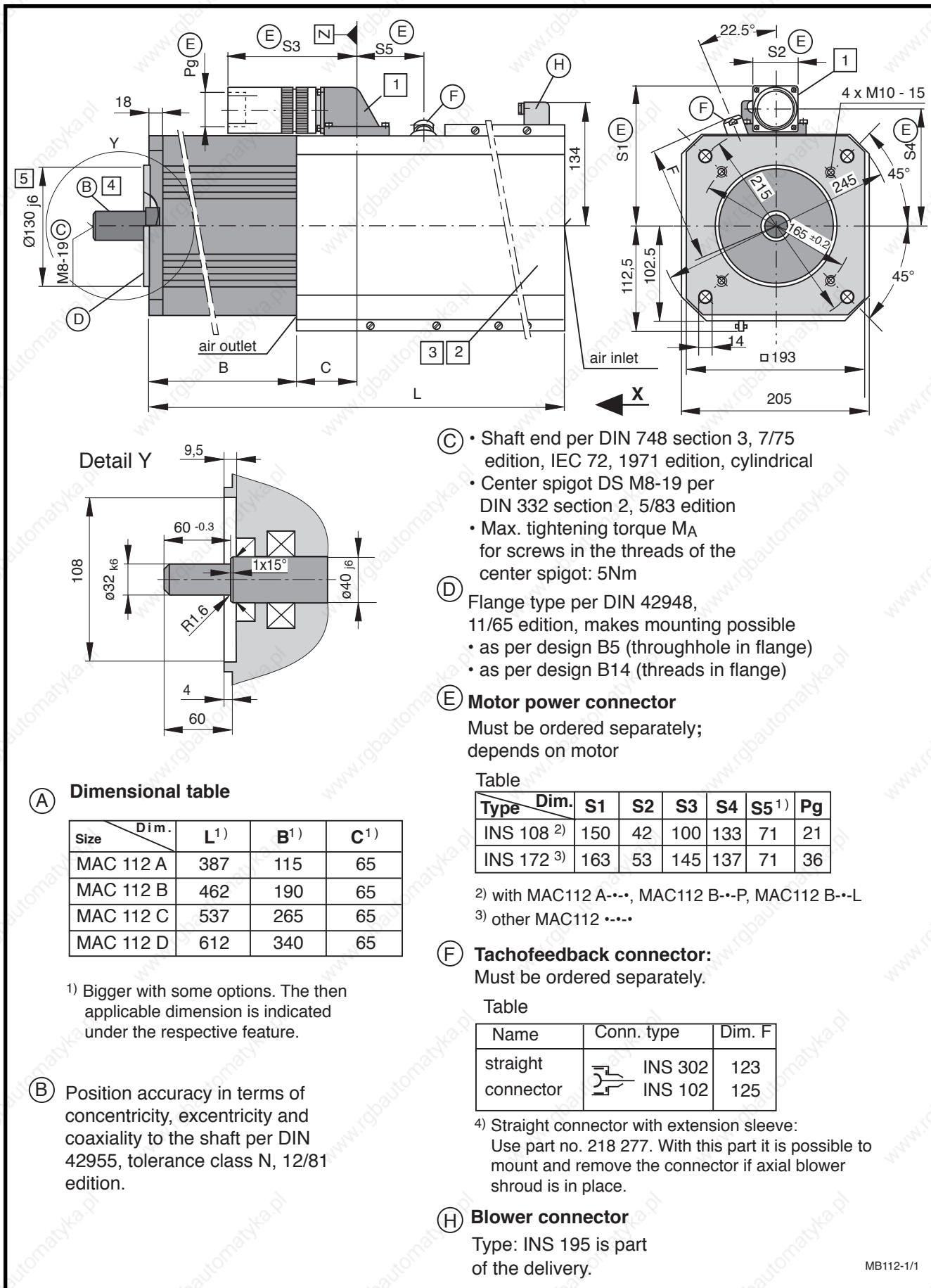

Fig 7.18: Dimensional data - MAC 112 (axial cooling)

Available options

1 Power connection

The output direction of the electrical power connector is selected at the time the order is placed. Possible output directions are:

- to side A
- to side B
- to the right
- to the left

The drawing depicts side A as output direction. The dimensions of any other direction are obtained by a virtual turning of the connector housing around the Z axis.

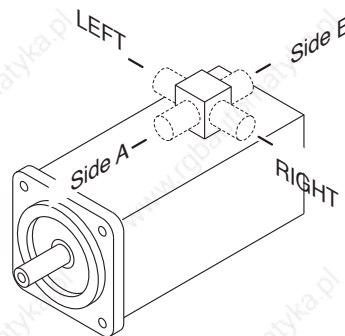

2 Motor version

- Tachofeedback and incremental encoder

Table

| Size | Dim. | L | B | C | S5 | S6 |
|-----------|------|-----|-----|----|----|-----|
| MAC 112 A | | 497 | 115 | 65 | 71 | 154 |
| MAC 112 B | | 572 | 190 | 65 | 71 | 154 |
| MAC 112 C | | 647 | 265 | 65 | 71 | 154 |
| MAC 112 D | | 722 | 340 | 65 | 71 | 154 |

Table for motors with blocking brakes of 40 Nm and 60 Nm

| Size | Dim. | L | B | C | S5 | S6 |
|-----------|------|-----|-----|----|-----|-----|
| MAC 112 B | | 622 | 192 | 17 | 119 | 154 |
| MAC 112 C | | 697 | 267 | 17 | 119 | 154 |
| MAC 112 D | | 772 | 342 | 17 | 119 | 154 |

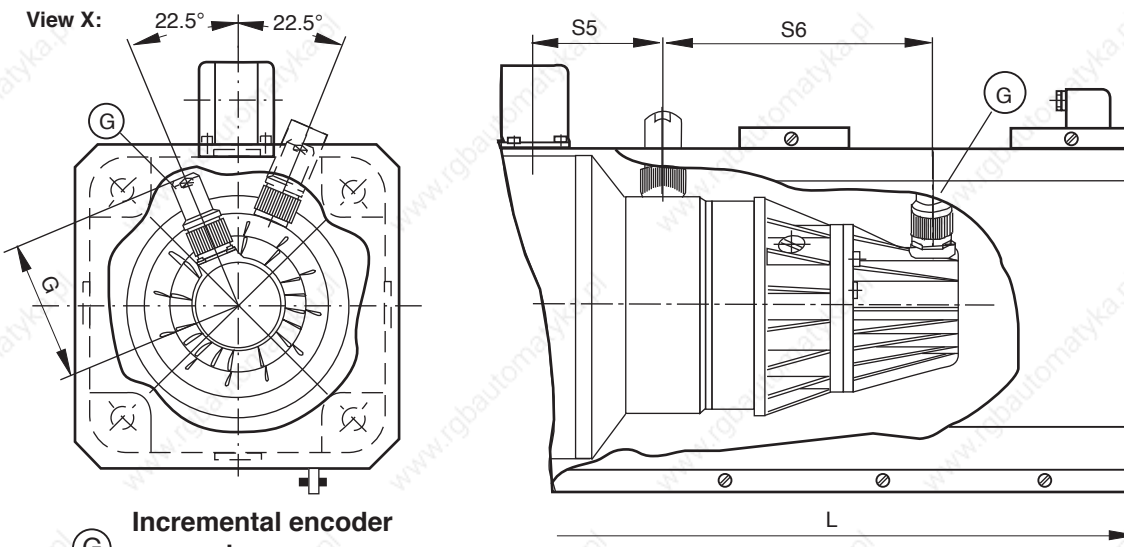

G Incremental encoder connector

Must be ordered separately.

| Name | Conn. type | Dim. G |
|----------|------------|-------------|
| straight | | INS 301 123 |
| conn. 1) | | INS 101 125 |

1) Straight connector with extending sleeve:
part no.: 218 277

- Tachofeedback and mounted absolute encoder (see following page)

MB112-1/2

Fig 7.19: Dimensional data - MAC 112 - available options - (axial cooling)

Available options

- Tachofeedback and mounted absolute encoder

Table

| Size | Dim. | L | B | C | S5 | S6 |
|-----------|------|-----|-----|----|----|----|
| MAC 112 A | | 497 | 115 | 65 | 71 | 84 |
| MAC 112 B | | 572 | 190 | 65 | 71 | 84 |
| MAC 112 C | | 647 | 265 | 65 | 71 | 84 |
| MAC 112 D | | 722 | 340 | 65 | 71 | 84 |

Table with blocking brake with 40 and 60 Nm holding torque

| Size | Dim. | L | B | C | S5 | S6 |
|-----------|------|-----|-----|----|-----|----|
| MAC 112 B | | 622 | 192 | 65 | 119 | 84 |
| MAC 112 C | | 697 | 267 | 65 | 119 | 84 |
| MAC 112 D | | 772 | 342 | 65 | 119 | 84 |

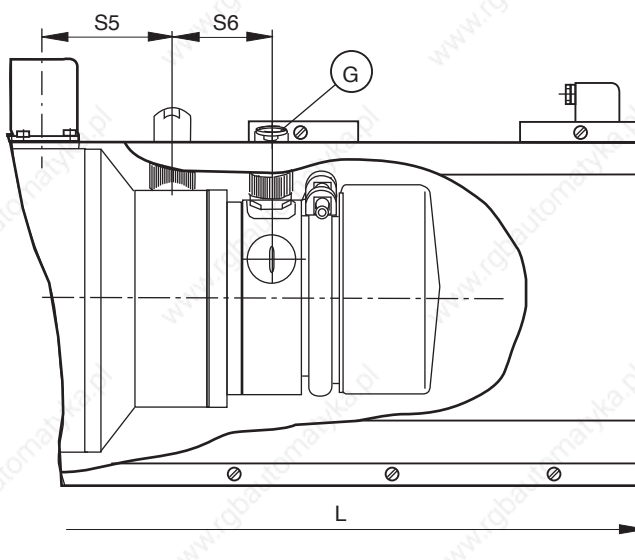
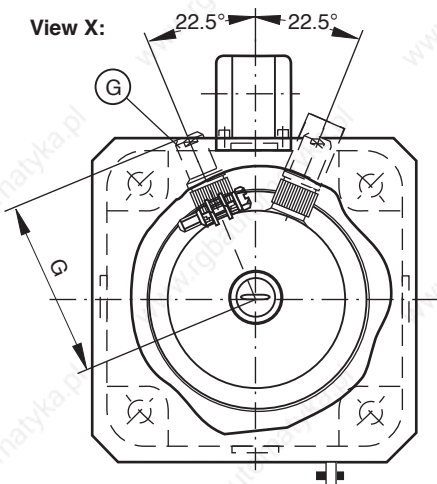

- G Absolute encoder conn.**
Must be ordered separately.

| Name | Conn. type | Dim. G |
|----------------|------------|--------|
| straight conn. | INS 326 | 104 |
| | INS 92 | 106 |

3 Blocking brake

- without blocking brake
Dim. L and B retained
- Standard blocking brake: 14 Nm
Dim. L and B retained
- heavy-duty blocking brake: 40 Nm
(not available with MAC 112A ...)
- extra heavy-duty blocking brake: 60 Nm
(not available with MAC 112A ...)

Table for blocking brake with 40 and 60 Nm

| Size | Dim. | | Vers. 2 | | Vers. 4 | |
|-----------|------|-----|---------|-----|---------|-----|
| | L | B | L | B | L | B |
| MAC 112 B | 512 | 240 | 622 | 240 | 622 | 240 |
| MAC 112 C | 587 | 315 | 697 | 315 | 697 | 315 |
| MAC 112 D | 662 | 390 | 772 | 390 | 772 | 390 |

Vers. 2 = Motor with tachofeedback
Vers. 4 = Motor with tachofeedback and mounted encoder

4 Output shaft

- plain shaft (recommended type)
- with keyway per DIN 6885 sh. 1, 8/68 edition
(Note! balanced with entire key.)

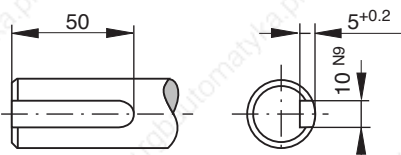

Matching key: DIN 6885-A 10 x 8 x 50
Must be ordered separately.

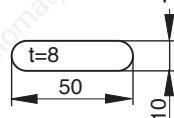

5 Special centering diameter

- $\varnothing 180 j6$

MB112-1/3

Fig 7.20: Dimensional data - MAC 112 - available options - (axial cooling)

7.7. Available Options

| Type code fields | | Example: | MAC 112 A-0-LD-4 - C/130-A-0/WI 520LV/S000 | | | | | | | |
|--|--|-------------------|--|-----------------|-----------------------------------|-------------|------------------|-------------|-------------|-------------|
| 1. Motor for analogue drives | | MAC | | | | | | | | |
| 2. Motor size | | 112 | | | | | | | | |
| 3. Motor length | | A, B, C, D | | | | | | | | |
| 4. Type of cooling: | | | | | | | | | | |
| natural convection | | | surface cooling | | | | | | | |
| | | | axial | | | | radial | | | |
| | | | | | blower right | | blower below | | blower left | |
| | | | AC 230 V | AC 115 V | AC 230 V | AC 115 V | AC 230 V | AC 115 V | AC 230 V | AC 115 V |
| 0 | | | 1 ¹⁾ | 2 ¹⁾ | 6 | A | 7 | B | 8 | C |
| 5. Type of windings | | | | | | | | | | |
| Nominal rpm | Standard applications | | | | with increased smooth run quality | | | | | |
| | motor length | | | | motor length | | | | | |
| | A | B | C | D | A | B | C | D | | |
| 1500 min ⁻¹ | ZD | PD | KD | HD | ZG | PG | KG | HG | | |
| 2000 min ⁻¹ | VD | LD | HD | FD | VG | LG | HG | FG | | |
| 3000 min ⁻¹ | LD | GD | ED | ED | LG | GG | EG | EG | | |
| 5000 min ⁻¹ | -- | -- | CD ⁶⁾ | -- | -- | -- | CG ⁶⁾ | -- | | |
| 6. Motor feedback | | | | | | | | | | |
| Motor type | | | | | | | | | | |
| with tachofeedback | | 2 | | | | | | | | |
| with tachofeedback and second shaft end | | 3 | | | | | | | | |
| with tachofeedback and mounted incremental or absolute encoder | | 4 | | | | | | | | |
| Tacho voltage | | | | | | | | | | |
| set to nominal motor speed | | - | | | | | | | | |
| (nominal rpm > 3000 min ⁻¹ : 1,5 V/1000 min ⁻¹) | | | | | | | | | | |
| (Nennzahl ≤ 3000 min ⁻¹ : 3 V/1000 min ⁻¹) | | | | | | | | | | |
| 1,5 V/1000 min ⁻¹ | | H | | | | | | | | |
| 6 V/1000 min ⁻¹ 3) | | L | | | | | | | | |
| Tacho type | | | | | | | | | | |
| Standard | | C | | | | | | | | |
| increased smooth run quality | | F | | | | | | | | |
| 7. Centering diameter | | | | | | | | | | |
| for design B05 and B14 | | 130 | | | | | | | | |
| for design B05 and B14 | | 180 ²⁾ | | | | | | | | |
| 8. Power connection | | | | | | | | | | |
| connector to side A | | A | | | | | | | | |
| connector to side B | | B | | | | | | | | |
| connector to right (looking onto output shaft) | | R | | | | | | | | |
| connector to lefth (looking towards output shaft) | | L | | | | | | | | |
| 9. Blocking brake | | | | | | | | | | |
| without blocking brake | | 0 | | | | | | | | |
| with standard blocking brake (45 Nm) | | 1 | | | | | | | | |
| with heavy-duty blocking brake (60 Nm) | | 2 2) 5) | | | | | | | | |
| extra heavy-duty blocking brake (60 Nm) | | 3 2) 5) | | | | | | | | |
| Mounted encoder | 10. Type ⁴⁾ | | | | | | | | | |
| | Incremental encoder with standard mounting | | WI | | | | | | | |
| | Incremental encoder with shock-damped mounting | | DI | | | | | | | |
| Absolute encoder | | AM | | | | | | | | |
| 11. Encoder code ⁴⁾ | | | | | | | | | | |
| For available types, see section 2.4 "Motor feedback" | | | | | | | | | | |
| 12. Special types | | | | | | | | | | |
| Fixed and documented by INDRAMAT with special number (see Drawing no.: 106-0105-4301-XX) | | | | | | | | | | |
| Does not apply to standard motors. | | | | | | | | | | |

1) For type 3 motors (with 2nd shaft end and tachofeedback). Not available with axial surface cooling.

2) Type code fields 10 and 11 do not apply to motor types 2 and 3.

3) only with tacho type "F"

4) type code fields 10 and 11 do not apply to motor types 2 and 3

5) not available with motor length A

6) not available with surface cooling

Fig 7.21: Type codes - MAC 112

7.8. Special Options

| Specification of Option | S003 | S005 | S011 | S013 | S018 | S019 | S029 |
|-----------------------------------|------|------|------|------|------|------|------|
| Special centering diameter 180 | X | | X | | | X | X |
| heavy-duty blocking brake | | | | X | X | X | X |
| with keyway per DIN 6885, sheet 1 | X | X | | | X | | X |

Fig 7.22: Special options with a MAC 112

8. MAC 115

8.1. Technical Data

| Designation | Symbol | Unit | Motor type MAC ... | | | |
|---|-------------------|-------------------|---------------------------|-------------------------|------------------------|------------------------|
| | | | | | | 115 D - - - ES |
| Nominal motor speed ¹⁾ | n | min ⁻¹ | | | | 1500 |
| Continuous torque at standstill ²⁾ | M _{dN} | Nm | | | | 57 (88) ⁵⁾ |
| Continuous current at standstill | I _{dN} | A | | | | 54 (84) ⁵⁾ |
| Rotor moment of inertia ³⁾ | J _M | kgm ² | | | | 271 x 10 ⁻⁴ |
| Torque constant at 20 °C | K _m | Nm/A | | | | 1.08 |
| Windings resistance at 20 °C | R _A | Ohm | | | | 0.084 |
| Windings inductance | L _A | mH | | | | 2.4 |
| Maximum peak of pulse current | I _{peak} | A | | | | 270 |
| Thermal time constant | T _{th} | min | | | | 90 (60) ⁵⁾ |
| Mass ⁴⁾ | m _M | kg | | | | 60 |
| | | | 115 A - - - HS | 115 B - - - GS | 115 C - - - ES | 115 D - - - DS |
| Nominal motor speed ¹⁾ | n | min ⁻¹ | 2000 | 2000 | 2000 | 2000 |
| Continuous torque at standstill ²⁾ | M _{dN} | Nm | 28 (42) ⁵⁾ | 38 (61) ⁵⁾ | 47 (75) ⁵⁾ | 57 (88) ⁵⁾ |
| Continuous current at standstill | I _{dN} | A | 32.5 (48.8) ⁵⁾ | 40.9 (66) ⁵⁾ | 55 (87) ⁵⁾ | 68 (104) ⁵⁾ |
| Rotor moment of inertia ³⁾ | J _M | kgm ² | 123 x 10 ⁻⁴ | 172 x 10 ⁻⁴ | 222 x 10 ⁻⁴ | 271 x 10 ⁻⁴ |
| Torque constant at 20 °C | K _m | Nm/A | 0.882 | 0.952 | 0.880 | 0.864 |
| Windings resistance at 20 °C | R _A | Ohm | 0.170 | 0.123 | 0.074 | 0.054 |
| Windings inductance | L _A | mH | 3.6 | 3.0 | 2.0 | 1.6 |
| Maximum peak of pulse current | I _{peak} | A | 163 | 205 | 274 | 338 |
| Thermal time constant | T _{th} | min | 90 (60) ⁵⁾ | 90 (60) ⁵⁾ | 90 (60) ⁵⁾ | 90 (60) ⁵⁾ |
| Mass ⁴⁾ | m _M | kg | 33 | 41 | 52 | 60 |
| | | | 115 A - - - FS | 115 B - - - DS | 115 C - - - CS | 115 D - - - CS |
| Nominal motor speed ¹⁾ | n | min ⁻¹ | 3000 | 3000 | 3000 | 3000 |
| Continuous torque at standstill ²⁾ | M _{dN} | Nm | 28 (42) ⁵⁾ | 38 (56) ⁵⁾ | 47 | 57 |
| Continuous current at standstill | I _{dN} | A | 48.8 (73.2) ⁵⁾ | 72 (109) ⁵⁾ | 91 | 90 |
| Rotor moment of inertia ³⁾ | J _M | kgm ² | 123 x 10 ⁻⁴ | 172 x 10 ⁻⁴ | 222 x 10 ⁻⁴ | 271 x 10 ⁻⁴ |
| Torque constant at 20 °C | K _m | Nm/A | 0.588 | 0.544 | 0.528 | 0.648 |
| Windings resistance at 20 °C | R _A | Ohm | 0.076 | 0.040 | 0.027 | 0.030 |
| Windings inductance | L _A | mH | 1.6 | 1.0 | 0.7 | 0.9 |
| Maximum peak of pulse current | I _{peak} | A | 244 | 358 | 456 | 451 |
| Thermal time constant | T _{th} | min | 90 (60) ⁵⁾ | 90 (60) ⁵⁾ | 90 (60) ⁵⁾ | 90 (60) ⁵⁾ |
| Mass ⁴⁾ | m _M | kg | 33 | 41 | 52 | 60 |

¹⁾ The usable motor speed is determined by the drive used.
 Only those usable speeds n_{max} found in the selection lists of the motor-drive combinations are binding.
²⁾ With 60K overtemperature at the motor housing.
 Continuous torque can be limited by the drive. See selection data.
³⁾ With tacho-generator, without holding brake
⁴⁾ With tacho-generator, without holding brake, without blower.
⁵⁾ Parenthetical values apply to versions with surface cooling.

Fig 8.1: Type-dependent motor data

| Designation | Symbol | Unit | Data | |
|--|----------|-------------------------------|--------------------------------|------------------|
| Permissible ambient temperature | T_{um} | °C | 0 ... + 45 | |
| Permissible storage and transport temperature | T_L | °C | -20 ... +80 | |
| Maximum installation elevation | | m | 1000 m above sea level | |
| Protection category | | | IP 65 | |
| Insulation classification | | | F | |
| Housing coat | | | Black prime coat (RAL 9005) | |
| Voltage constant of the tachogenerator ¹⁾ | C_w | Vs/rad V/min ⁻¹ | 0.0143 1.5/1000 | 0.0286 3/1000 |

¹⁾ Tachovoltage can be selected application-related.

Fig 8.2: General data MAC 115

| Designation | Symbol | Unit | Data holding brake | |
|---------------------|--------|------------------|----------------------|-------------------------------|
| | | | Standard | heavy-duty |
| Principle of action | | | | electrically actuated release |
| Holding torque | M_H | Nm | 45 | 60 |
| Nominal voltage | U_N | V | | DC 24 ± 10% |
| Nominal current | I_N | A | 1.0 | 1.5 |
| Moment of inertia | J_B | kgm ² | 9.5×10^{-4} | 32×10^{-4} |
| Release delay | t_L | ms | 55 | 150 |
| Clamping delay | t_K | ms | 18 | 30 |
| Mass | m_B | kg | 1.9 | 3.5 |

Fig 8.3: Technical data -holding brake

| Designation | Symbol | Unit | Axial cooling | Radial cooling |
|----------------------------------|--------|------|-----------------------------|-----------------------------|
| Power consumption | S_N | VA | 40/42 | 40/42 |
| Nominal voltage | U_N | V | AC 230 or 115 ¹⁾ | AC 230 or 115 ¹⁾ |
| Frequency | f | Hz | 50/60 | 50/60 |
| Mass | m_L | kg | approx. 3.3 ²⁾ | approx. 3.2 ²⁾ |
| Protection category blower unit | | | IP 24 | IP 24 |
| Protection category blower motor | | | IP 44 | IP 44 |

¹⁾ 115 V special design
²⁾ Blower shroud for motor with tachofeedback.

Fig 8.4: Technical data - surface cooling

8.2. Torque-Speed Characteristics

MAC 115 A - • - HS
2000 min⁻¹

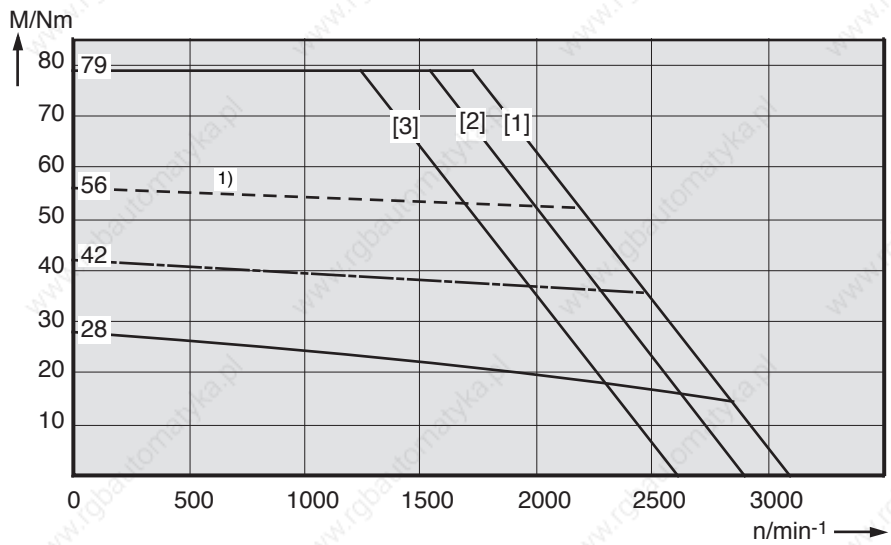

MAC 115 A - • - FS
3000 min⁻¹

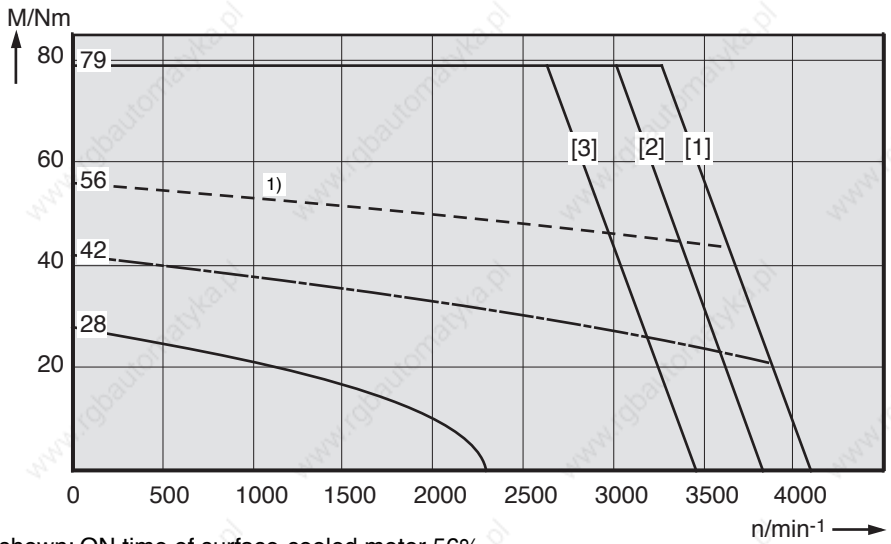

1) shown: ON time of surface-cooled motor 56%

Fig 8.5: Torque-speed characteristics MAC 115

MAC 115 B - - - GS
2000 min⁻¹

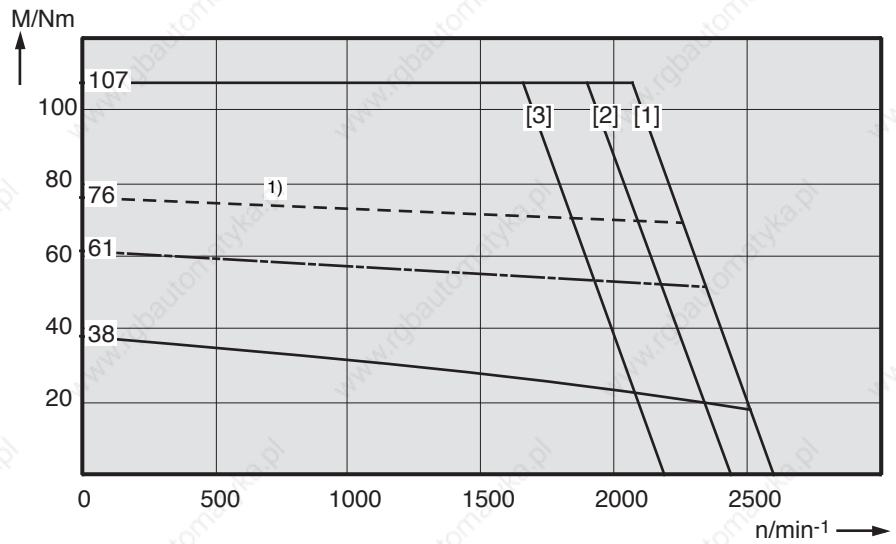

MAC 115 B - - - DS
3000 min⁻¹

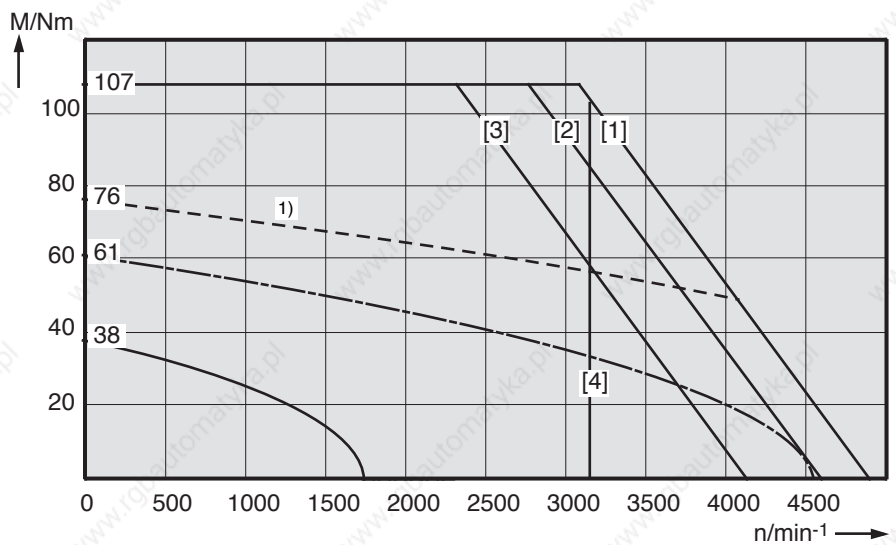

¹⁾ shown: ON time of surface-cooled motor 64%

Fig 8.6: Torque-speed characteristics MAC 115

MAC 115 C - - - ES
2000 min⁻¹

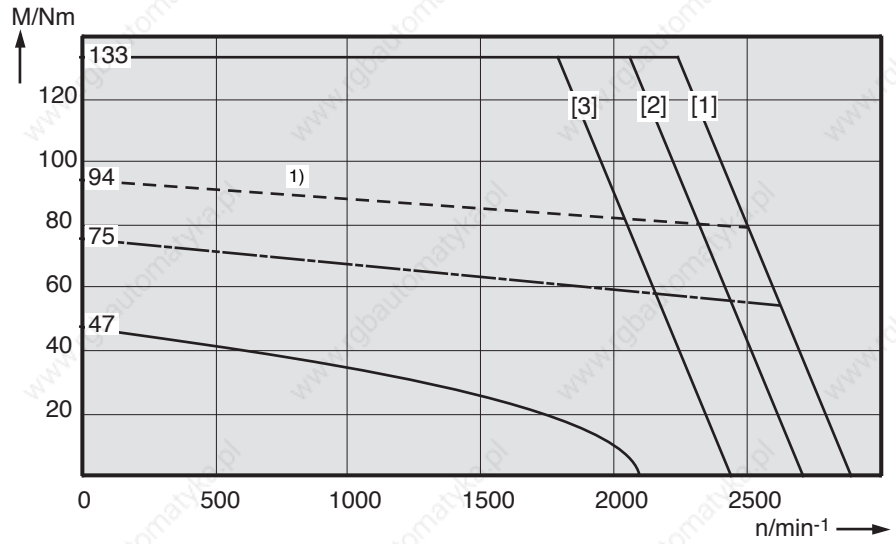

MAC 115 C - - - CS
3000 min⁻¹

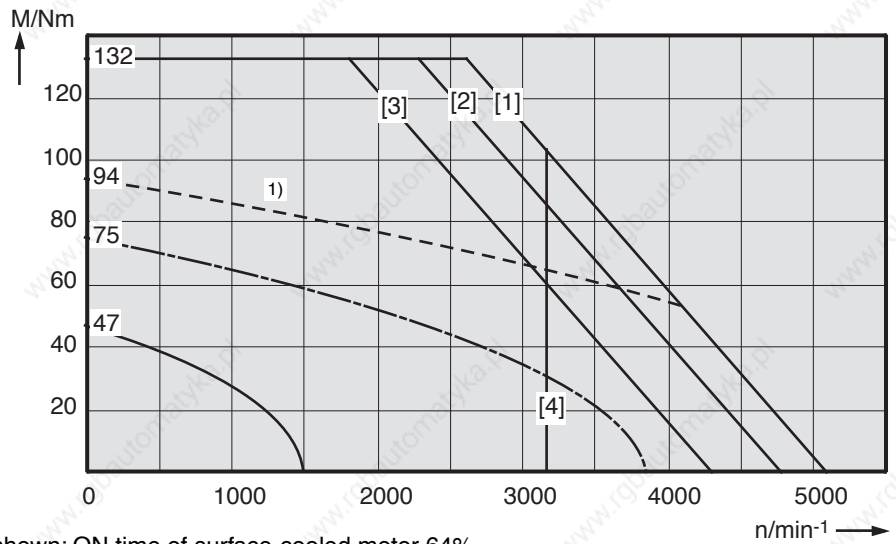

1) shown: ON time of surface-cooled motor 64%

Fig 8.7: Torque-speed characteristics MAC 115

MAC 115 D - - - ES
1500 min⁻¹

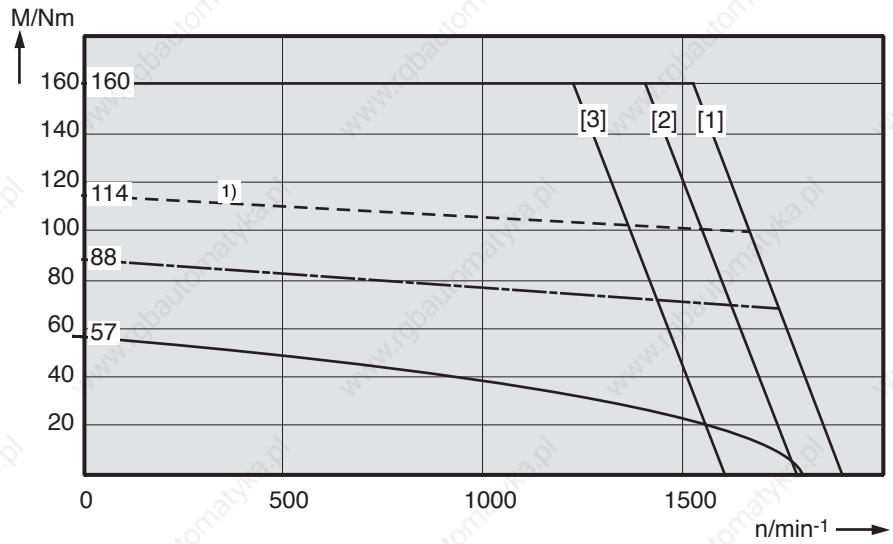

MAC 115 D - - - DS
2000 min⁻¹

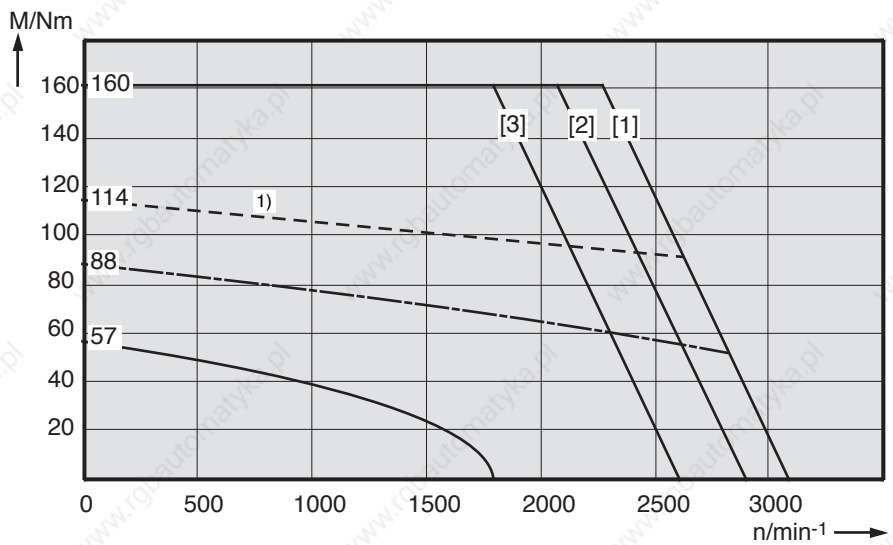

MAC 115 D - - - CS
3000 min⁻¹

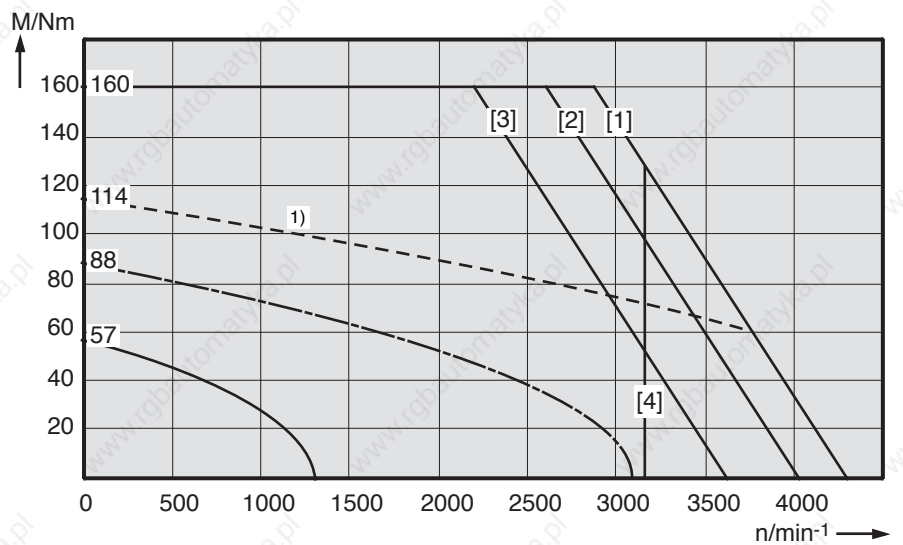

¹⁾ shown: ON time of surface-cooled motor 60%

Fig 8.8: Torque-speed characteristics MAC 115

8.3. Shaft load capacity

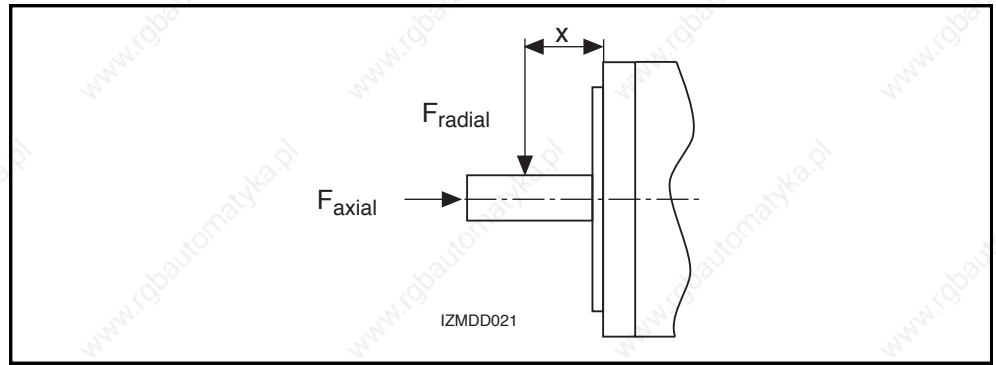

Fig 8.9: Shaft load

Permissible radial force
 F_{radial}

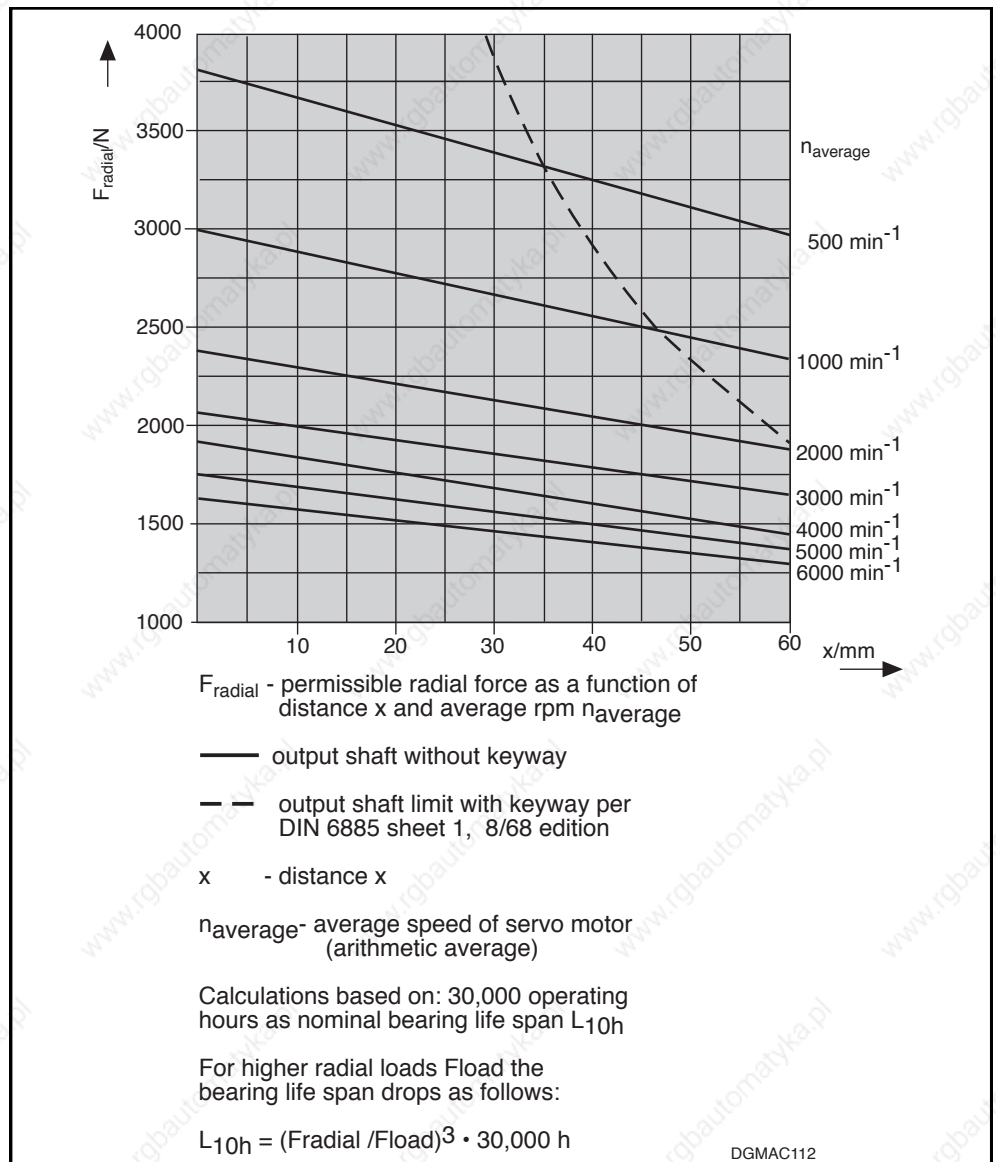

Fig 8.10: Permissible radial force

Permissible axial force
 F_{axial}

$$F_{axial} = 0.35 \cdot F_{radial}$$

F_{axial} - Permissible axial force
 F_{radial} - Permissible radial force

8.4. Dimensional data - natural convection

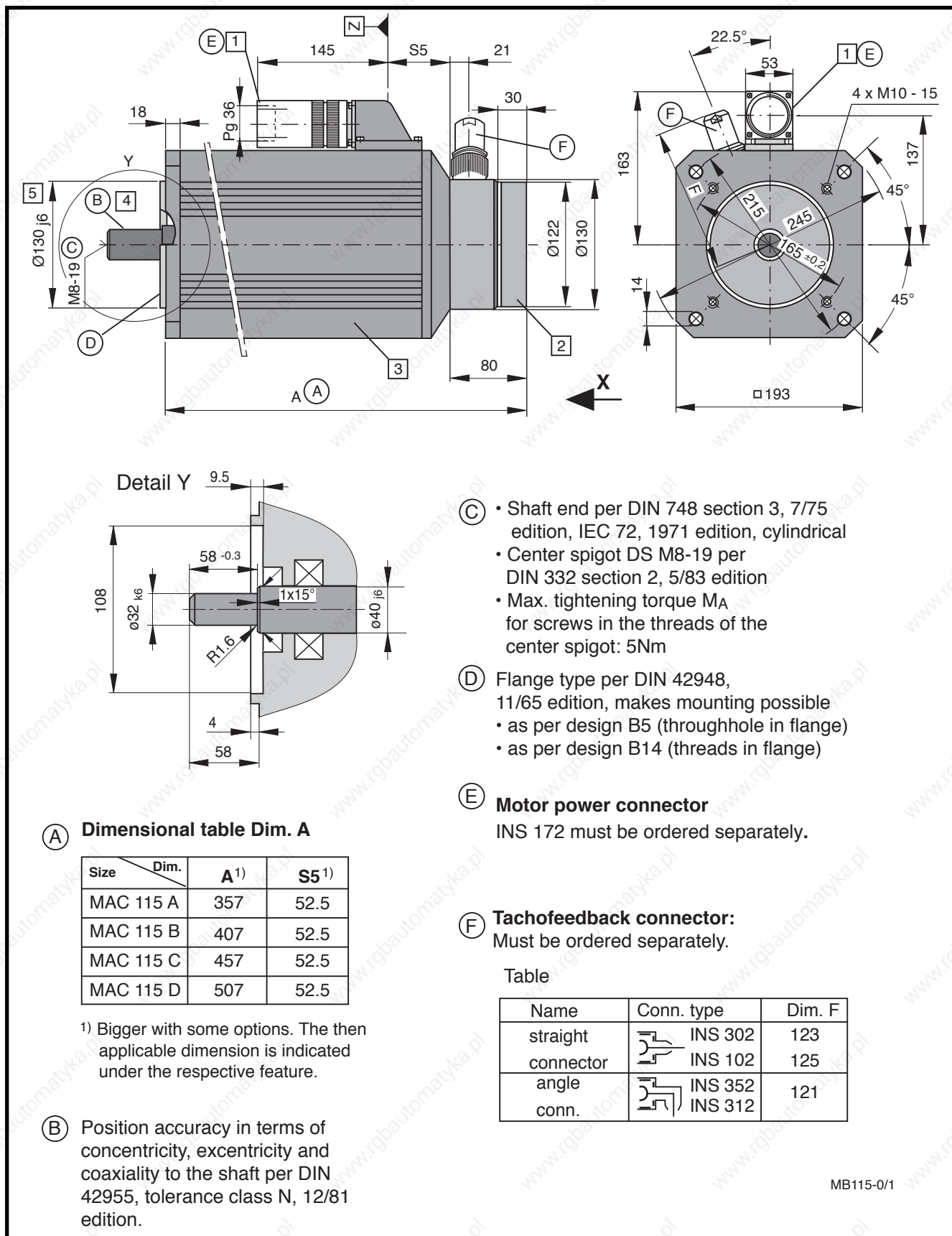

Fig 8.11: Dimensional data - MAC 115 (natural convection)

Available options

1 Power connection

The output direction of the electrical power connector is selected at the time the order is placed. Possible output directions are:

- to side A
- to side B
- to the right
- to the left

The drawing depicts side A as output direction. The dimensions of any other direction are obtained by a virtual turning of the connector housing around the Z axis.

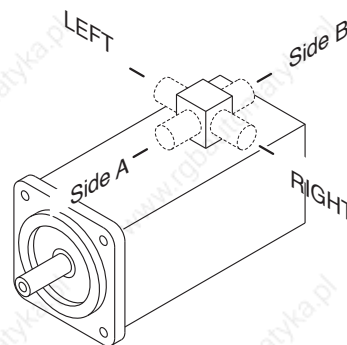

2 Motor version

- Tachofeedback and second shaft end

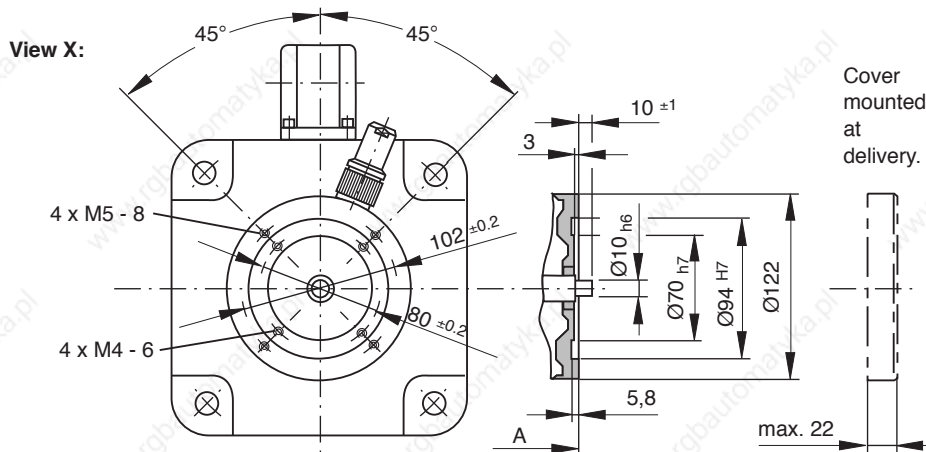

- Tachofeedback and mounted incremental encoder

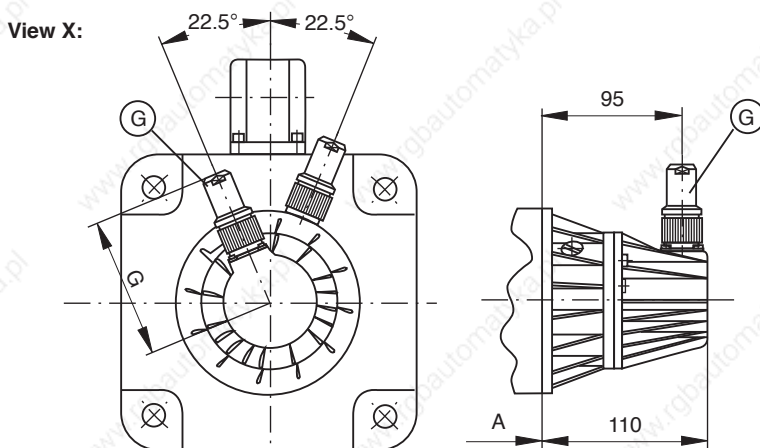

G Incremental encoder connector

Must be ordered separately.

| Name | Conn. type | Dim. G |
|----------------|--------------------|--------|
| straight conn. | INS 301 | 88 |
| | INS 101 | 90 |
| angle conn. | INS 351 INS 311 | 86 |

- Tachofeedback and mounted absolute encoder (see following page)

MB115-0/2

Fig 8.12: Dimensional data - MAC 115 - available options - (natural convection)



Available options

- Tachofeedback and mounted absolute encoder

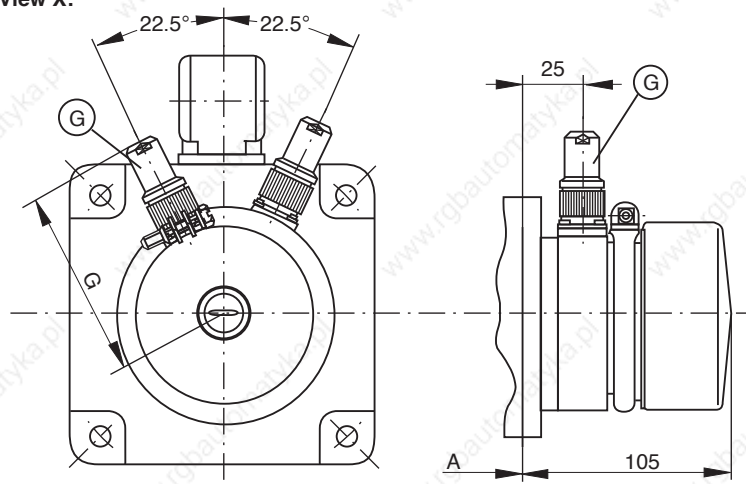
View X:



G Absolute encoder connector
Must be ordered separately.

| Name | Connector | Dim. G |
|----------------|---|--------|
| straight conn. |  INS 326 | 104 |
| |  INS 92 | 106 |
| angle conn. |  INS 322 | 102 |

3 Blocking brake

- without blocking brake
Dim. A and S5 are retained.
- Standard blocking brake: 45 Nm
Dim. A and S5 are retained.
- heavy-duty blocking brake: 60 Nm

Table for motors with 60 Nm blocking brakes

| Size \ Dim. | A | S5 |
|-------------|-----|------|
| MAC 115 A | 417 | 95.5 |
| MAC 115 B | 467 | 95.5 |
| MAC 115 C | 517 | 95.5 |
| MAC 115 D | 567 | 95.5 |

4 Output shaft

- plain shaft (preferred)
- with keyway as per DIN 6885 sheet 1, 8/68 edition
(Note! Balanced with entire key.)

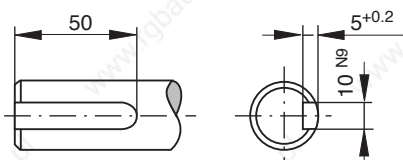

Matching key: DIN 6885-A 10 x 8 x 50
Must be ordered separately.

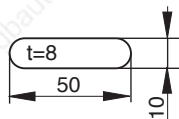

5 Special centering diameter

- $\varnothing 180 j6$

MB115-0/3

Fig 8.13: Dimensional data - MAC 115 -available options - (natural convection)

8.5. Dimensional data - radial cooling

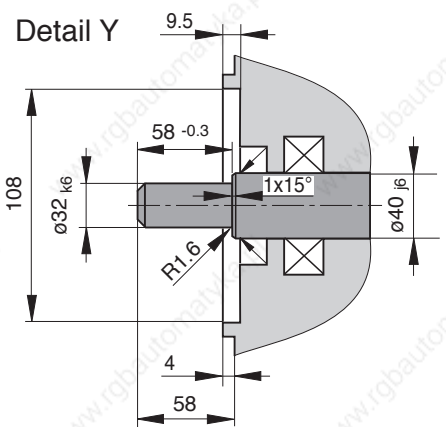
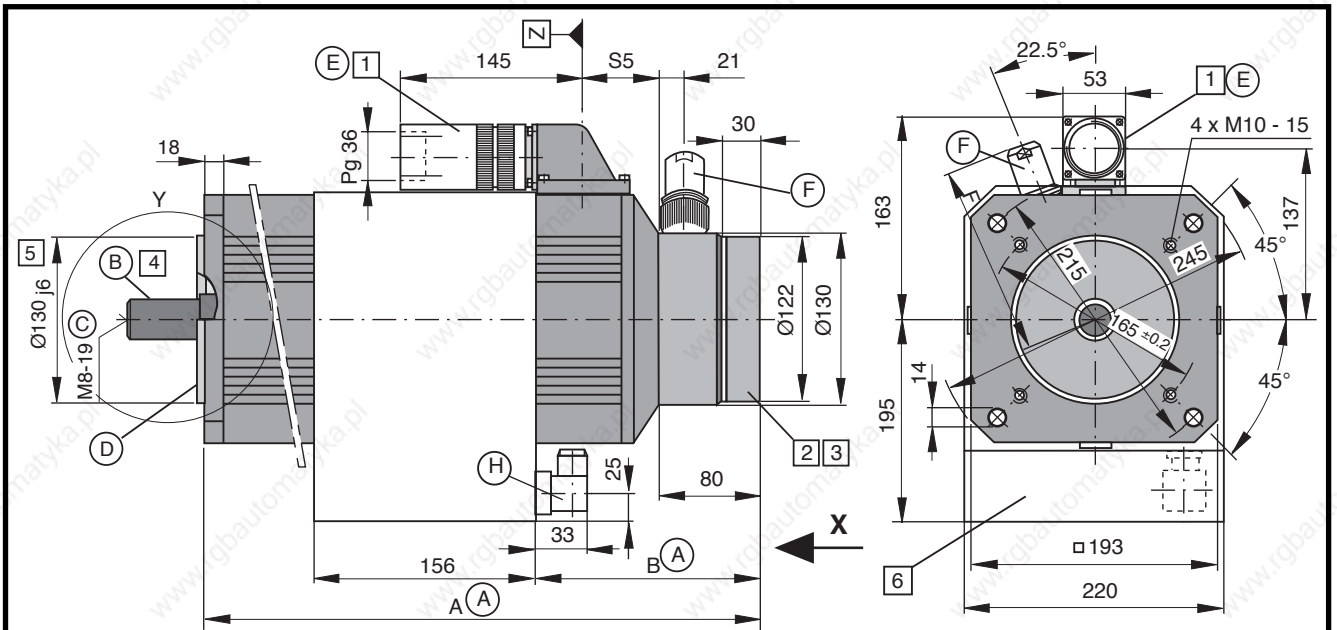

- (C) • Shaft end per DIN 748 section 3, 7/75 edition, IEC 72, 1971 edition, cylindrical
- Center spigot DS M8-19 per DIN 332 section 2, 5/83 edition
- Max. tightening torque M_A for screws in the threads of the center spigot: 5 Nm
- (D) Flange type per DIN 42948, 11/65 edition, makes mounting possible
- as per design B5 (throughhole in flange)
- as per design B14 (threads in flange)
- (E) **Motor power connector**
INS 172 must be ordered separately.

(A) Dimensional table Dim. A and B

| Size \ Dim. | A ¹⁾ | B ¹⁾ | S5 ¹⁾ |
|-------------|-----------------|-----------------|------------------|
| MAC 115 A | 357 | 110 | 52.5 |
| MAC 115 B | 407 | 170 | 52.5 |
| MAC 115 C | 457 | 205 | 52.5 |
| MAC 115 D | 507 | 205 | 52.5 |

1) Bigger with some options. The then applicable dimension is indicated under the respective feature.

(B) Position accuracy in terms of concentricity, excentricity and coaxiality to the shaft per DIN 42955, tolerance class N, 12/81 edition.

(F) **Tachofeedback connector:**
Must be ordered separately.

Table

| Name | Conn. type | Dim. F |
|--------------------|------------|--------|
| straight connector | INS 302 | 123 |
| | INS 102 | 125 |
| angle conn. | INS 352 | 121 |
| | INS 312 | |

(H) **Blower connector: INS 195**
Part of general delivery.

MB115-1rad/1

Fig 8.14: Dimensional data - MAC 115 (radial cooling)

Available options

1 Power connection

The output direction of the electrical power connector is selected at the time the order is placed. Possible output directions are:

- to side A
- to side B
- to the right
- to the left

The drawing depicts side A as output direction. The dimensions of any other direction are obtained by a virtual turning of the connector housing around the Z axis.

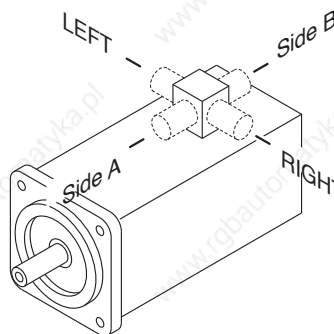

2 Motor version

- Tachofeedback and second shaft end

View X:

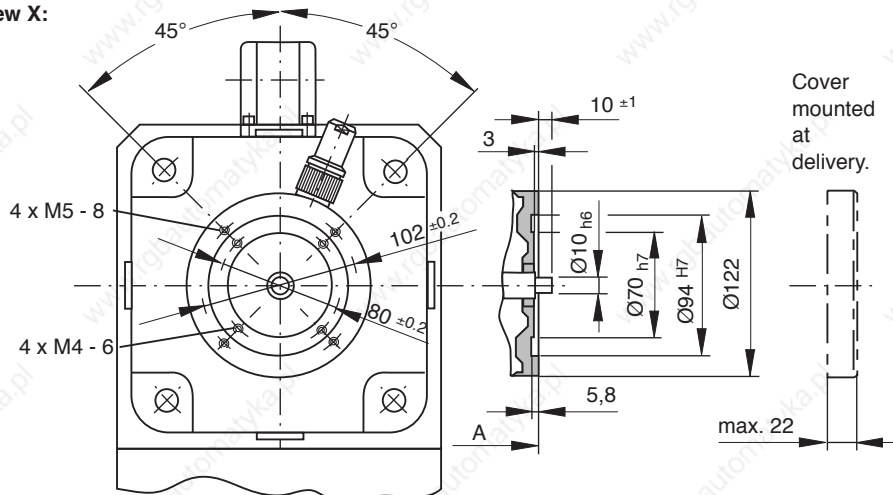

- Tachofeedback and mounted incremental encoder

View X:

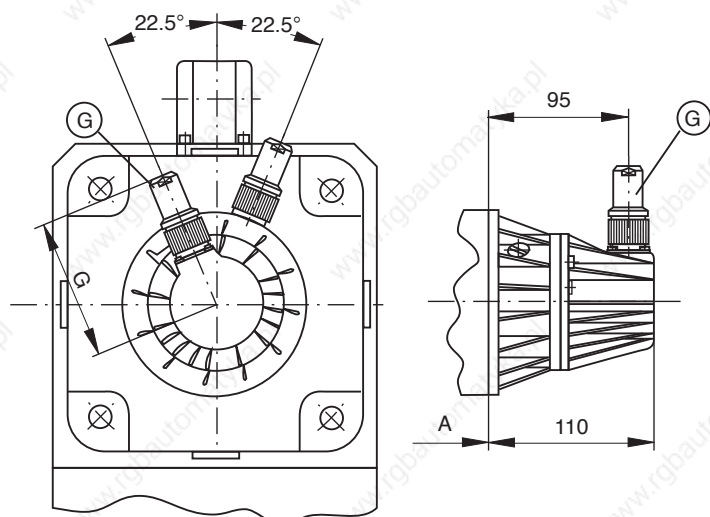

G Incremental encoder connector

Must be ordered separately.

| Name | Conn. type | Dim. G |
|----------------|------------|--------|
| straight conn. | INS 301 | 88 |
| | INS 101 | 90 |
| angle conn. | INS 351 | 86 |
| | INS 311 | |

- Tachofeedback and mounted absolute encoder (see following page)

MB115-1rad/2

Fig 8.15: Dimensional data - MAC 115 - available options - (radial cooling)

Available options

- Tachofeedback and mounted absolute encoder

View X:

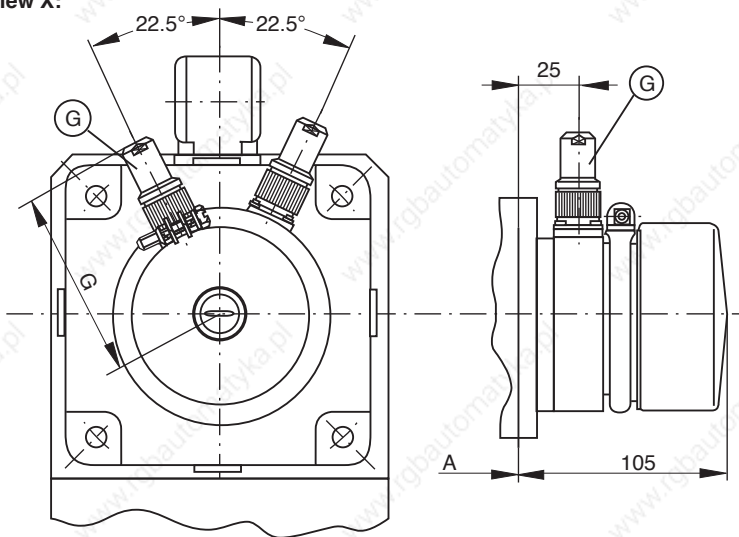

G Absolute encoder conn.
Must be ordered separately.

| Name | Conn. type | Dim. G |
|----------------|------------|--------|
| straight conn. | INS 326 | 104 |
| | INS 92 | 106 |
| angle conn. | INS 322 | 102 |

3 Blocking brake

- without blocking brake
Dim. A, B and S5 retained
- Standard blocking brake: 45 Nm
Dim. A, B and S5 retained
- heavy-duty blocking brake: 60 Nm

Table for blocking brake with 60 Nm

| Size \ Dim. | A | B | S5 |
|-------------|-----|-----|------|
| MAC 115 A | 417 | 155 | 95.5 |
| MAC 115 B | 467 | 225 | 95.5 |
| MAC 115 C | 517 | 255 | 95.5 |
| MAC 115 D | 567 | 255 | 95.5 |

4 Output shaft

- plain shaft (recommended type)
- with keyway per DIN 6885 sh. 1, 8/68 edition
(Note! balanced with entire key.)

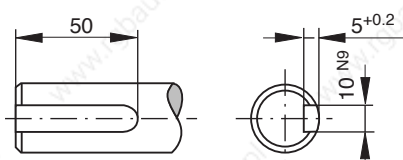

Matching key: DIN 6885-A 10 x 8 x 50
Must be ordered separately.

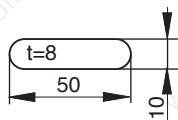

5 Special centering diameter

- $\varnothing 180 j6$

6 Blower arrangement

Looking towards motor shaft.

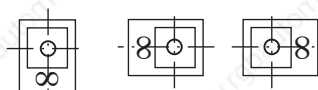

below

left

right

MB115-1rad/3

Fig 8.16: Dimensional data - MAC 115 - available options - (radial cooling)

8.6. Dimensional data - axial cooling

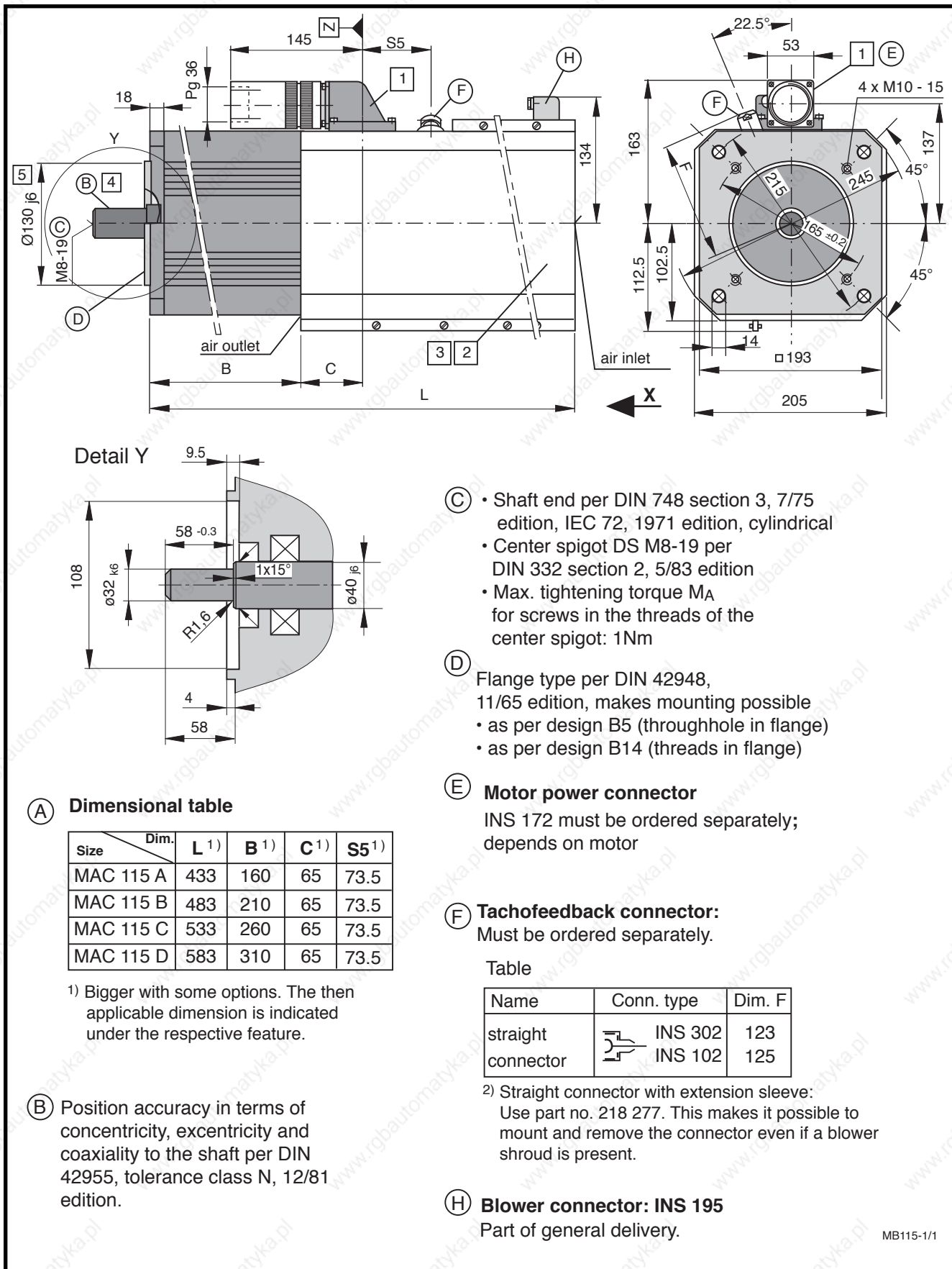

Fig 8.17: Dimensional data - MAC 115 (axial cooling)

Available options

1 Power connection

The output direction of the electrical power connector is selected at the time the order is placed. Possible output directions are:

- to side A
- to side B
- to the right
- to the left

The drawing depicts side A as output direction. The dimensions of any other direction are obtained by a virtual turning of the connector housing around the Z axis.

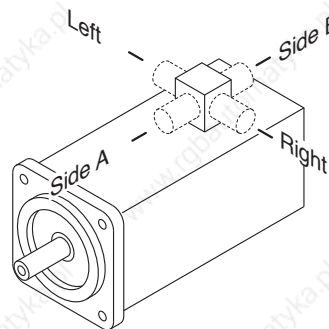

2 Motor type

- Tachofeedback and mounted incremental encoder

Table

| Size | Dim. | L | B | C | S5 | S6 |
|-----------|------|-----|-----|----|------|-----|
| MAC 115 A | | 543 | 160 | 65 | 73.5 | 154 |
| MAC 115 B | | 593 | 210 | 65 | 73.5 | 154 |
| MAC 115 C | | 643 | 260 | 65 | 73.5 | 154 |
| MAC 115 D | | 693 | 310 | 65 | 73.5 | 154 |



Table for motor with 60 Nm blocking brake

| Size | Dim. | L | B | C | S5 | S6 |
|-----------|------|-----|-----|----|-------|-----|
| MAC 115 A | | 603 | 220 | 22 | 116.5 | 154 |
| MAC 115 B | | 653 | 270 | 22 | 116.5 | 154 |
| MAC 115 C | | 703 | 320 | 22 | 116.5 | 154 |
| MAC 115 D | | 753 | 370 | 22 | 116.5 | 154 |

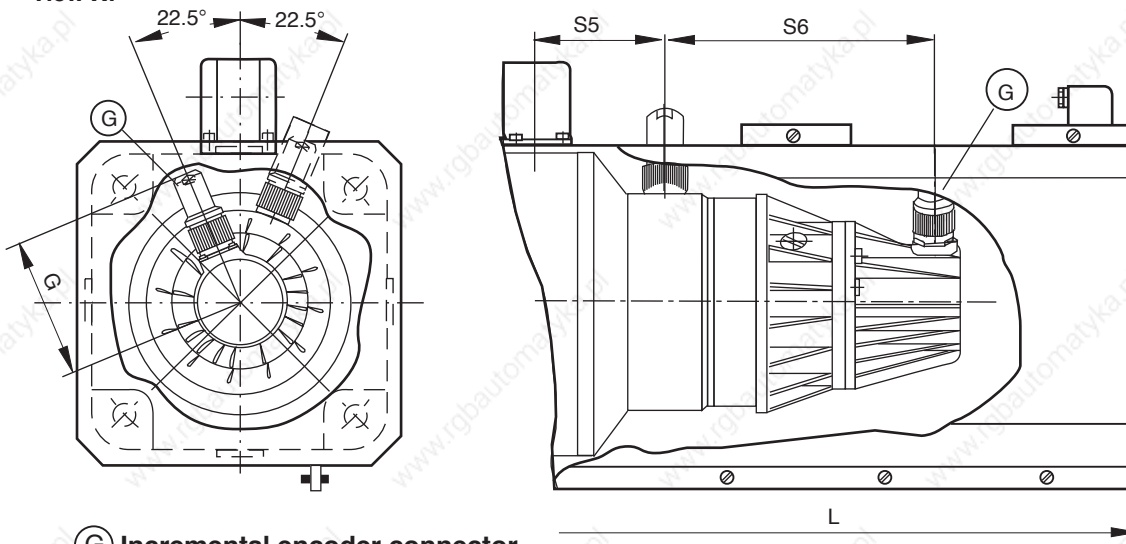
View X:



G Incremental encoder connector
Must be ordered separately.

| Name | Connector | Dim. G |
|--------------------|---|--------|
| gerader Stecker 1) |  INS 302 | 123 |
| |  INS 102 | 125 |

1) Straight connector with extension sleeve:
part no.: 218 277

- Tachofeedback and mounted absolute encoder (see next page)

MB115-1/2

Fig 8.18: Dimensional data - MAC 115 - available options - (axial cooling)

Available options

- Tachofeedback and mounted absolute encoder

Table

| Size | Dim. | L | B | C | S5 | S6 |
|-----------|------|-----|-----|----|------|----|
| MAC 115 A | | 543 | 160 | 65 | 73.5 | 84 |
| MAC 115 B | | 593 | 210 | 65 | 73.5 | 84 |
| MAC 115 C | | 643 | 260 | 65 | 73.5 | 84 |
| MAC 115 D | | 693 | 310 | 65 | 73.5 | 84 |

Table of blocking brake with 60 Nm holding torque

| Size | Dim. | L | B | C | S5 | S6 |
|-----------|------|-----|-----|----|-------|----|
| MAC 115 A | | 603 | 220 | 22 | 116.5 | 84 |
| MAC 115 B | | 653 | 270 | 22 | 116.5 | 84 |
| MAC 115 C | | 703 | 320 | 22 | 116.5 | 84 |
| MAC 115 D | | 753 | 370 | 22 | 116.5 | 84 |

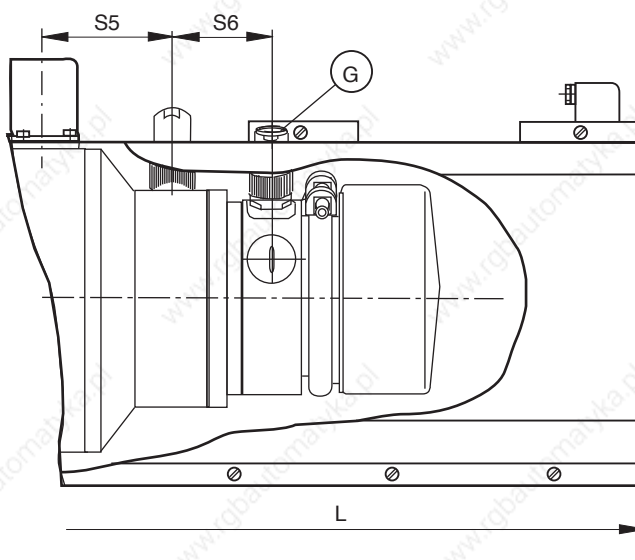
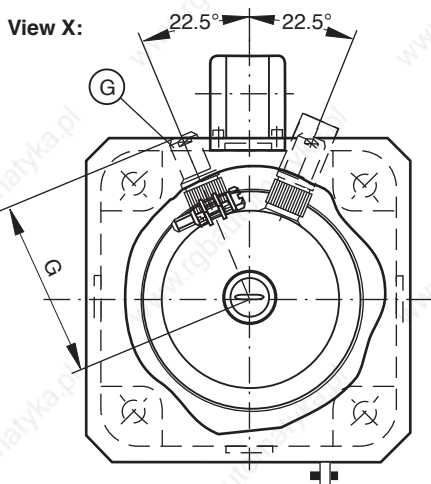

G Absolute encoder conn.
Must be ordered separately.

| Name | Conn. type | Dim. G |
|----------------|-------------------|------------|
| straight conn. | INS 326 INS 92 | 104 106 |

3 Blocking brake

- without blocking brake
Dim. L and B retained
- Standard blocking brake: 45 Nm
Dim. L and B retained
- heavy-duty blocking brake: 60 Nm

Table for blocking brake with 60 Nm

| Size | Dim. | Vers. 2 | | | Vers. 4 | | |
|-----------|------|---------|-----|-------|---------|-----|-------|
| | | L | B | S5 | L | B | S5 |
| MAC 115 A | | 543 | 160 | 116.5 | 603 | 222 | 116.5 |
| MAC 115 B | | 593 | 210 | 116.5 | 653 | 270 | 116.5 |
| MAC 115 C | | 643 | 260 | 116.5 | 703 | 320 | 116.5 |
| MAC 115 D | | 693 | 310 | 116.5 | 753 | 370 | 116.5 |

Vers. 2 = Motor with tachofeedback
Vers. 4 = Motor with tachofeedback and mounted encoder

4 Output shaft

- plain shaft (recommended type)
- with keyway per DIN 6885 sh. 1, 8/68 edition
(Note! balanced with entire key.)

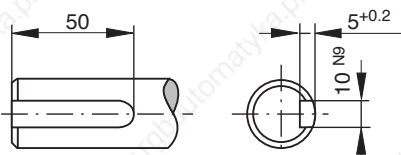

Matching key: DIN 6885-A 10 x 8 x 50
Must be ordered separately.

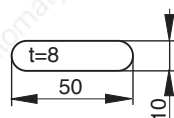

5 Special centering diameter

- $\varnothing 180 j6$

MB115-1/3

Fig 8.19: Dimensional data - MAC 115 - available options - (axial cooling)

8.7. Available Options

| Type code fields | | Example: | MAC 115 A-0-HS-4 - C/130-A-0/WI 520LV/S000 | | | | | | | |
|--|--|----------|---|-----------------|--------------|----------|-------------|----------|----------|----------|
| 1. Motor for analogue drives | MAC | | | | | | | | | |
| 2. Motor size | 115 | | | | | | | | | |
| 3. Motor length | A, B, C, D | | | | | | | | | |
| 4. Type of cooling: | | | | | | | | | | |
| natural convection | | | surface cooling | | | | | | | |
| | | | axial | | | | radial | | | |
| | | | blower right | | blower below | | blower left | | | |
| | | | AC 230 V | AC 115 V | AC 230 V | AC 115 V | AC 230 V | AC 115 V | AC 230 V | AC 115 V |
| 0 | | | 1 ¹⁾ | 2 ¹⁾ | 6 | A | 7 | B | 8 | C |
| 5. Type of windings | | | Motor length | | | | | | | |
| Nominal rpm | | | A | B | C | D | | | | |
| 1500 min ⁻¹ | -- | | -- | -- | -- | ES | | | | |
| 2000 min ⁻¹ | HS | | GS | ES | DS | | | | | |
| 3000 min ⁻¹ | FS | | DS | CS | CS | | | | | |
| 6. Motor feedback | | | | | | | | | | |
| Motor type | | | | | | | | | | |
| with tachofeedback | | | 2 | | | | | | | |
| with tachofeedback and second shaft end | | | 3 | | | | | | | |
| with tachofeedback and mounted incremental or absolute encoder | | | 4 | | | | | | | |
| Tacho voltage | | | | | | | | | | |
| set to nominal motor speed | | | - | | | | | | | |
| (nominal rpm > 3000 min ⁻¹) | | | - ¹ : 1.5 V/1000 min ⁻¹) | | | | | | | |
| (nominal rpm ≤ 3000 min ⁻¹) | | | - ¹ : 3 V/1000 min ⁻¹) | | | | | | | |
| 1.5 V/1000 min ⁻¹ | | | H | | | | | | | |
| Tacho type | | | | | | | | | | |
| Standard | | | C | | | | | | | |
| increased smooth run quality | | | F | | | | | | | |
| 7. Centering diameter | | | | | | | | | | |
| for design B05 and B14 | | | 130 | | | | | | | |
| for design B05 and B14 | | | 180 | | | | | | | |
| 8. Power connection | | | | | | | | | | |
| connector to side A | | | A | | | | | | | |
| connector to side B | | | B | | | | | | | |
| connector to right (looking onto output shaft) | | | R | | | | | | | |
| connector to left (looking onto output shaft) | | | L | | | | | | | |
| 9. Blocking brake | | | | | | | | | | |
| without blocking brake | | | 0 | | | | | | | |
| with standard blocking brake (45 Nm) | | | 1 | | | | | | | |
| with heavy-duty blocking brake (60 Nm) | | | 2 | | | | | | | |
| Mounted encoder | 10. Type ²⁾ | | | | | | | | | |
| | Incremental encoder with standard mounting | | WI | | | | | | | |
| Incremental encoder with shock-damped mounting | | DI | | | | | | | | |
| Absolute encoder | | AM | | | | | | | | |
| 11. Encoder code ²⁾ | | | | | | | | | | |
| For available types, see section 2.4 "Motor feedback" | | | | | | | | | | |
| 12. Special types | | | | | | | | | | |
| Fixed and documented by INDRAMAT with special number (see Drawing no.: 106-0105-4301-XX) | | | | | | | | | | |
| Does not apply to standard motors. | | | | | | | | | | |

Fig 8.20: Type codes MAC 115

TLMAC115

8.8. Special Options

| | |
|-----------------------------------|------|
| Specification of Option | S001 |
| with keyway per DIN 6885, sheet 1 | X |

Fig 8.21: Special options with a MAC 115

9. Electrical Power Connection

9.1. Terminal Diagram

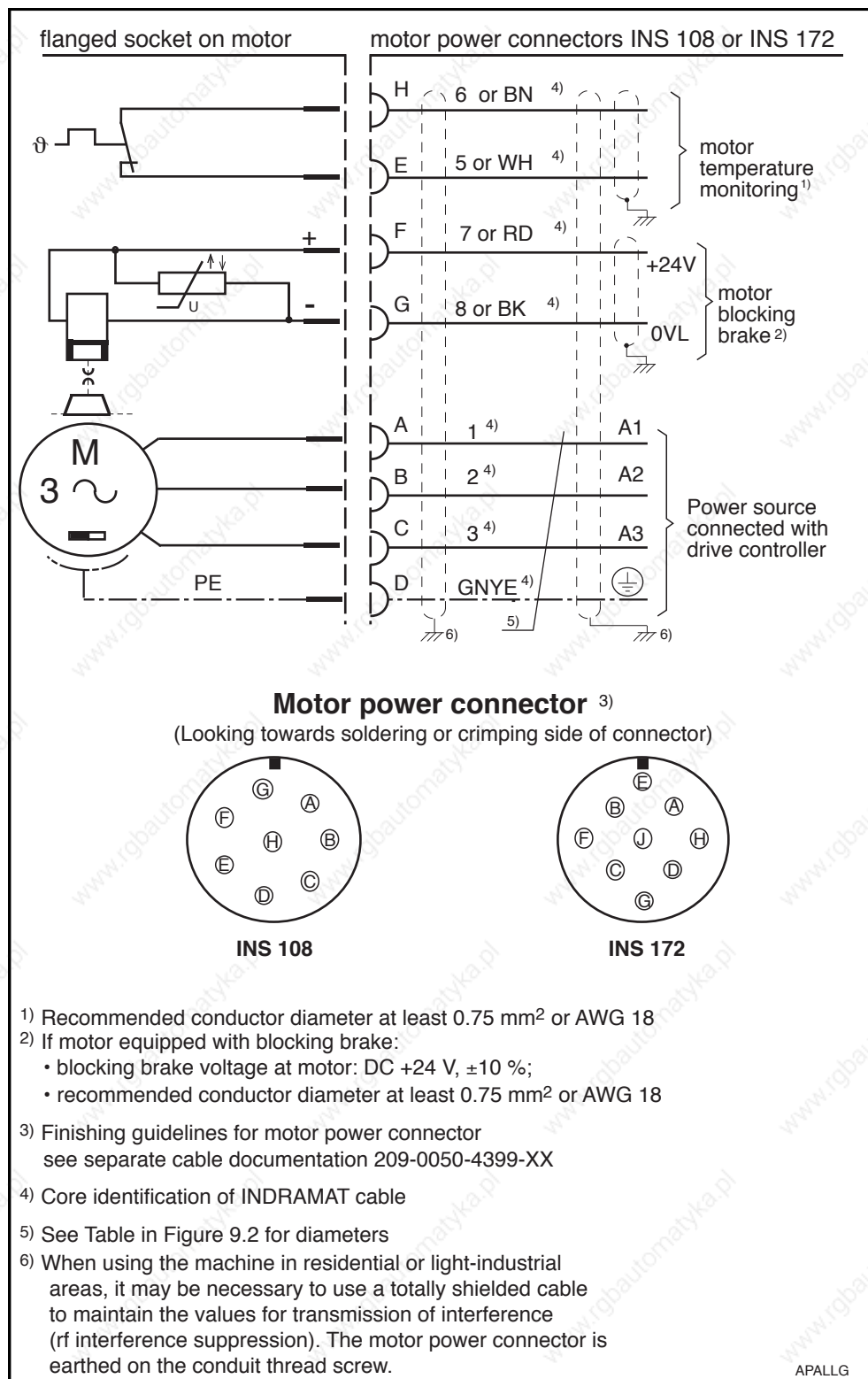

Fig 9.1: Power connection

9.2. Connector-Cable Allocations

| Servo motor MAC ... | Cooling | Motor phase current ¹⁾ A | Power conn. Min. cross section ¹⁾ | | Motor power connector | | INDRAMAT Motor power cable | | | |
|---|-----------------------|--|---|-------------------|--------------------------------|---------------------------------|-------------------------------|-------------------------|-------------------------------------|------|
| | | | mm ² | AWG ²⁾ | Crimping Type ³⁾ | Soldering type ³⁾ | w/o total shield | with total shield | cross section mm ² | |
| 063 A-0-ES | natural convection | 1.8 | 0.75 | 18 | --- | INS 108/06 | INK 253 | INK 653 | 0.75 | |
| 063 A-0-RS | | 2.9 | 0.75 | 18 | --- | INS 108/06 | INK 253 | INK 653 | 0.75 | |
| 063 B-0-GS | | 3.0 | 0.75 | 18 | --- | INS 108/06 | INK 253 | INK 653 | 0.75 | |
| 063 B-0-JS | | 4.7 | 0.75 | 18 | --- | INS 108/06 | INK 253 | INK 653 | 0.75 | |
| 063 C-0-MS | | 3.3 | 0.75 | 18 | --- | INS 108/06 | INK 253 | INK 653 | 0.75 | |
| 063 C-0-HS | | 5.6 | 0.75 | 18 | --- | INS 108/06 | INK 253 | INK 653 | 0.75 | |
| 063 D-0-JS | | 4.2 | 0.75 | 18 | --- | INS 108/06 | INK 253 | INK 653 | 0.75 | |
| 063 D-0-FS | | 6.9 | 0.75 | 18 | --- | INS 108/06 | INK 253 | INK 653 | 0.75 | |
| 063 A--ES | | surface cooling | 2.2 | 0.75 | 18 | --- | INS 108/06 | INK 253 | INK 653 | 0.75 |
| 063 A--RS | | | 3.6 | 0.75 | 18 | --- | INS 108/06 | INK 253 | INK 653 | 0.75 |
| 063 B--GS | 3.3 | | 0.75 | 18 | --- | INS 108/06 | INK 253 | INK 653 | 0.75 | |
| 063 B--JS | 5.4 | | 0.75 | 18 | --- | INS 108/06 | INK 253 | INK 653 | 0.75 | |
| 063 C--MS | 4.3 | | 0.75 | 18 | --- | INS 108/06 | INK 253 | INK 653 | 0.75 | |
| 063 C--HS | 7.1 | | 0.75 | 16 | --- | INS 108/06 | INK 253 | INK 653 | 0.75 | |
| 063 D--JS | 5.4 | | 0.75 | 18 | --- | INS 108/06 | INK 253 | INK 653 | 0.75 | |
| 063 D--FS | 9.0 | | 0.75 | 16 | --- | INS 108/06 | INK 253 | INK 653 | 0.75 | |
| Continued on next page | | | | | | | | | | |
| <p>¹⁾ Motor phase currents and connection cross sections apply to S1 continuous operation or S6 intermittent operation with those limit values (respective ON time and duty cycle time) given in the torque-speed operating curves.</p> <p>²⁾ Minimum cross section of power connection per EN 60 204, sec. 1, table 5, cols. C or E or UL 508 table 50.2, but at least 0.75 mm² or AWG 18. Cables per UL 508 may only be soldered not crimped to the motor power connector.</p> <p>³⁾ Data following the slash identify the type of bushing contact as either for crimping or soldering.</p> | | | | | | | | | | |

| Servo motor MAC ... | Cooling | Motor phase current ¹⁾ | Power conn. Min. cross section ¹⁾ | | Motor power connector | | INDRAMAT Motor power cable | | | |
|------------------------|-----------------------|---|---|-------------------|--------------------------------|---------------------------------|-------------------------------|-------------------------|-------------------------------------|------|
| | | | mm ² | AWG ²⁾ | Crimping Type ³⁾ | Soldering type ³⁾ | w/o total shield | with total shield | cross section mm ² | |
| | | | | | | | | | | A |
| 071 A-0-HS | natural convection | 2.1 | 0.75 | 18 | --- | INS 108/06 | INK 253 | INK 653 | 0.75 | |
| 071 A-0-OS | | 3.1 | 0.75 | 18 | --- | INS 108/06 | INK 253 | INK 653 | 0.75 | |
| 071 A-0-ES | | 4.1 | 0.75 | 18 | --- | INS 108/06 | INK 253 | INK 653 | 0.75 | |
| 071 A-0-VS | | 6.0 | 0.75 | 18 | --- | INS 108/06 | INK 253 | INK 653 | 0.75 | |
| 071 B-0-FS | | 4.2 | 0.75 | 18 | --- | INS 108/06 | INK 253 | INK 653 | 0.75 | |
| 071 B-0-TS | | 6.0 | 0.75 | 18 | --- | INS 108/06 | INK 253 | INK 653 | 0.75 | |
| 071 B-0-PS | | 7.8 | 0.75 | 16 | --- | INS 108/06 | INK 253 | INK 653 | 0.75 | |
| 071 B-0-KS | | 11.6 | 1.0 | 14 | --- | INS 108/06 | INK 250 | INK 650 | 1.5 | |
| 071 C-0-US | | 6.0 | 0.75 | 18 | --- | INS 108/06 | INK 253 | INK 653 | 0.75 | |
| 071 C-0-NS | | 9.0 | 0.75 | 16 | --- | INS 108/06 | INK 253 | INK 653 | 0.75 | |
| 071 C-0-JS | | 12.5 | 1.5 | 14 | INS 108/02 | INS 108/06 | INK 250 | INK 650 | 1.5 | |
| 071 C-0-GS | | 18.0 | 2.5 | 12 | INS 108/03 | INS 108/06 | INK 202 | INK 602 | 2.5 | |
| 071 A--HS | | surface cooling | 3.3 | 0.75 | 18 | --- | INS 108/06 | INK 253 | INK 653 | 0.75 |
| 071 A--OS | | | 4.9 | 0.75 | 18 | --- | INS 108/06 | INK 253 | INK 653 | 0.75 |
| 071 A--ES | | | 6.4 | 0.75 | 18 | --- | INS 108/06 | INK 253 | INK 653 | 0.75 |
| 071 A--VS | | | 9.5 | 1.0 | 16 | --- | INS 108/06 | INK 250 | INK 650 | 1.5 |
| 071 B--FS | 6.4 | | 0.75 | 18 | --- | INS 108/06 | INK 253 | INK 653 | 0.75 | |
| 071 B--TS | 9.5 | | 1.0 | 16 | --- | INS 108/06 | INK 250 | INK 650 | 1.5 | |
| 071 B--PS | 12.4 | | 1.5 | 14 | INS 108/02 | INS 108/06 | INK 250 | INK 650 | 1.5 | |
| 071 B--KS | 18.2 | | 2.5 | 12 | INS 108/03 | INS 108/06 | INK 202 | INK 602 | 2.5 | |
| 071 C--US | 9.6 | | 1.0 | 16 | --- | INS 108/06 | INK 253 | INK 653 | 1.5 | |
| 071 C--NS | 14.4 | | 2.5 | 14 | INS 108/03 | INS 108/06 | INK 202 | INK 602 | 2.5 | |
| 071 C--JS | 20.2 | | 4.0 | 10 | INS 108/04 | INS 108/06 | INK 203 | INK 603 | 4.0 | |
| 071 C--GS | 28.9 | | 6.0 | 10 | INS 108/06 | INS 108/06 | INK 204 | INK 604 | 6.0 | |

Continued on next page

¹⁾ Motor phase currents and connection cross sections apply to S1 continuous operation or S6 intermittent operation with those limit values (respective ON time and duty cycle time) given in the torque-speed operating curves.
²⁾ Minimum cross section of power connection per EN 60 204, sec. 1, table 5, cols. C or E or UL 508 table 50.2, but at least 0.75 mm² or AWG 18. Cables per UL 508 may only be soldered not crimped to the motor power connector.
³⁾ Data following the slash identify the type of bushing contact as either for crimping or soldering.

| Servo motor MAC ... | Cooling | Motor phase current ¹⁾ A | Power conn. Min. cross section ¹⁾ | | Motor power connector | | INDRAMAT Motor power cable | | |
|---|-----------------------|--|---|-------------------|--------------------------------|---------------------------------|-------------------------------|-------------------------|-------------------------------------|
| | | | mm ² | AWG ²⁾ | Crimping Type ³⁾ | Soldering type ³⁾ | w/o total shield | with total shield | cross section mm ² |
| 090 A-0-Z• | natural convection | 6.6 | 0.75 | 18 | --- | INS 108/06 | INK 253 | INK 653 | 0.75 |
| 090 A-0-R• | | 9.3 | 1.0 | 16 | INS 108/02 | INS 108/06 | INK 250 | INK 650 | 1.5 |
| 090 B-0-P• | | 9.7 | 1.0 | 16 | INS 108/02 | INS 108/06 | INK 250 | INK 650 | 1.5 |
| 090 B-0-N• | | 10.6 | 1.0 | 14 | INS 108/02 | INS 108/06 | INK 250 | INK 650 | 1.5 |
| 090 B-0-J• | | 14.8 | 1.5 | 14 | INS 108/02 | INS 108/06 | INK 250 | INK 650 | 1.5 |
| 090 C-0-K• | | 13.9 | 1.5 | 14 | INS 108/02 | INS 108/06 | INK 250 | INK 650 | 1.5 |
| 090 C-0-G• | | 20.2 | 2.5 | 10 | INS 108/03 | INS 108/06 | INK 202 | INK 602 | 2.5 |
| 090 C-0-E• | | 28.6 | 6.0 | 10 | --- | INS 108/06 | INK 204 | INK 604 | 6.0 |
| 090 A--Z• | | surface cooling | 8.9 | 0.75 | 16 | --- | INS 108/06 | INK 253 | INK 653 |
| 090 A--R• | 13.3 | | 1.5 | 14 | INS 108/02 | INS 108/06 | INK 250 | INK 650 | 1.5 |
| 090 B--P• | 14.2 | | 1.5 | 14 | INS 108/02 | INS 108/06 | INK 250 | INK 650 | 1.5 |
| 090 B--N• | 16.3 | | 2.5 | 12 | INS 108/03 | INS 108/06 | INK 202 | INK 602 | 2.5 |
| 090 B--J• | 23.2 | | 4.0 | 10 | INS 108/04 | INS 108/06 | INK 203 | INK 603 | 4.0 |
| 090 C--K• | 21.3 | | 4.0 | 10 | INS 108/04 | INS 108/06 | INK 203 | INK 603 | 4.0 |
| 090 C--G• | 33.7 | | 6.0 | 8 | --- | INS 108/06 | INK 204 | INK 604 | 6.0 |
| 090 C--E• | 42.5 | | 10.0 | 6 | INS 172/10 | INS 172/25 | INK 205 | INK 605 | 10.0 |
| Continued on next page | | | | | | | | | |
| ¹⁾ Motor phase currents and connection cross sections apply to S1 continuous operation or S6 intermittent operation with those limit values (respective ON time and duty cycle time) given in the torque-speed operating curves. ²⁾ Minimum cross section of power connection per EN 60 204, sec. 1, table 5, cols. C or E or UL 508 table 50.2, but at least 0.75 mm ² or AWG 18. Cables per UL 508 may only be soldered not crimped to the motor power connector. ³⁾ Data following the slash identify the type of bushing contact as either for crimping or soldering. | | | | | | | | | |

| Servo motor MAC ... | Cooling | Motor phase current ¹⁾ | Power conn. Min. cross section ¹⁾ | | Motor power connector | | INDRAMAT Motor power cable | | | |
|------------------------|-----------------------|---|---|-------------------|--------------------------------|---------------------------------|-------------------------------|-------------------------|-------------------------------------|-----|
| | | | mm ² | AWG ²⁾ | Crimping Type ³⁾ | Soldering type ³⁾ | w/o total shield | with total shield | cross section mm ² | |
| | | | | | | | | | | A |
| 093 A-0-WS | natural convection | 9.0 | 1.0 | 16 | INS 108/02 | INS 108/06 | INK 250 | INK 650 | 1.5 | |
| 093 A-0-PS | | 12.3 | 1.5 | 14 | INS 108/02 | INS 108/06 | INK 250 | INK 650 | 1.5 | |
| 093 A-0-LS | | 18.0 | 2.5 | 12 | INS 108/03 | INS 108/06 | INK 202 | INK 602 | 2.5 | |
| 093 A-0-HS | | 26.2 | 4.0 | 10 | INS 108/04 | INS 108/06 | INK 203 | INK 603 | 4.0 | |
| 093 B-0-OS | | 14.8 | 1.5 | 14 | INS 108/02 | INS 108/06 | INK 250 | INK 650 | 1.5 | |
| 093 B-0-JS | | 22.1 | 4.0 | 10 | INS 108/04 | INS 108/06 | INK 203 | INK 603 | 4.0 | |
| 093 B-0-GS | | 31.2 | 6.0 | 8 | INS 172/06 | INS 172/25 | INK 204 | INK 604 | 6.0 | |
| 093 B-0-ES | | 44.3 | 10.0 | 6 | INS 172/10 | INS 172/25 | INK 205 | INK 605 | 10.0 | |
| 093 C-0-KS | | 18.0 | 2.5 | 12 | INS 108/03 | INS 108/06 | INK 202 | INK 602 | 2.5 | |
| 093 C-0-FS | | 28.7 | 6.0 | 10 | INS 172/06 | INS 172/25 | INK 204 | INK 604 | 6.0 | |
| 093 C-0-DS | | 39.4 | 10.0 | 8 | INS 172/10 | INS 172/25 | INK 205 | INK 605 | 10.0 | |
| 093 C-0-CS | | 49.2 | 10.0 | 6 | INS 172/10 | INS 172/25 | INK 205 | INK 605 | 10.0 | |
| 093 A--WS | | surface cooling | 15.1 | 1.5 | 12 | INS 108/02 | INS 108/06 | INK 250 | INK 650 | 1.5 |
| 093 A--PS | | | 16.4 | 2.5 | 12 | INS 108/03 | INS 108/06 | INK 202 | INK 602 | 2.5 |
| 093 A--LS | | | 23.0 | 4.0 | 10 | INS 108/04 | INS 108/06 | INK 203 | INK 603 | 4.0 |
| 093 A--HS | | | 28.0 | 4.0 | 10 | INS 108/04 | INS 108/06 | INK 203 | INK 603 | 4.0 |
| 093 B--OS | 20.5 | | 2.5 | 10 | INS 108/03 | INS 108/06 | INK 202 | INK 602 | 2.5 | |
| 093 B--JS | 28.0 | | 4.0 | 10 | INS 108/04 | INS 108/06 | INK 203 | INK 603 | 4.0 | |
| 093 B--GS | 43.5 | | 10.0 | 6 | INS 172/10 | INS 172/25 | INK 205 | INK 605 | 10.0 | |
| 093 B--ES | 60.7 | | 16.0 | 4 | INS 172/16 | INS 172/25 | INK 206 | INK 606 | 16.0 | |
| 093 C--KS | 26.2 | | 4.0 | 10 | INS 108/04 | INS 108/06 | INK 203 | INK 603 | 4.0 | |
| 093 C--FS | 41.0 | | 10.0 | 6 | INS 172/10 | INS 172/25 | INK 205 | INK 605 | 10.0 | |
| 093 C--DS | 56.6 | | 16.0 | 4 | INS 172/16 | INS 172/25 | INK 206 | INK 606 | 16.0 | |
| 093 C--CS | 71.3 | | 25.0 | 3 | INS 172/25 | INS 172/25 | INK 207 | INK 607 | 25.0 | |

Continued on next page

1) Motor phase currents and connection cross sections apply to S1 continuous operation or S6 intermittent operation with those limit values (respective ON time and duty cycle time) given in the torque-speed operating curves.
2) Minimum cross section of power connection per EN 60 204, sec. 1, table 5, cols. C or E or UL 508 table 50.2, but at least 0.75 mm² or AWG 18. Cables per UL 508 may only be soldered not crimped to the motor power connector.
3) Data following the slash identify the type of bushing contact as either for crimping or soldering.

| Servo motor MAC ... | Cooling | Motor phase current ¹⁾ | Power conn. Min. cross section ¹⁾ | | Motor power connector | | INDRAMAT Motor power cable | | | |
|------------------------|-----------------------|---|---|-------------------|--------------------------------|---------------------------------|-------------------------------|-------------------------|-------------------------------------|-----|
| | | | mm ² | AWG ²⁾ | Crimping Type ³⁾ | Soldering type ³⁾ | w/o total shield | with total shield | cross section mm ² | |
| | | | | | | | | | | A |
| 112 A-0-Z• | natural convection | 11.8 | 1.5 | 14 | INS 108/02 | INS 108/06 | INK 250 | INK 650 | 1.5 | |
| 112 A-0-V• | | 15.1 | 1.5 | 12 | INS 108/02 | INS 108/06 | INK 250 | INK 650 | 1.5 | |
| 112 A-0-L• | | 25.3 | 4.0 | 10 | INS 108/04 | INS 108/06 | INK 203 | INK 603 | 4.0 | |
| 112 B-0-P• | | 17.1 | 2.5 | 10 | INS 108/03 | INS 108/06 | INK 202 | INK 602 | 2.5 | |
| 112 B-0-L• | | 21.5 | 4.0 | 10 | INS 108/04 | INS 108/06 | INK 203 | INK 603 | 4.0 | |
| 112 B-0-G• | | 33.5 | 6.0 | 8 | --- | INS 108/06 | INK 204 | INK 604 | 6.0 | |
| 112 C-0-K• | | 25.3 | 4.0 | 10 | INS 108/04 | INS 108/06 | INK 203 | INK 603 | 4.0 | |
| 112 C-0-H• | | 33.5 | 6.0 | 8 | --- | INS 108/06 | INK 204 | INK 604 | 6.0 | |
| 112 C-0-E• | | 46.5 | 10.0 | 6 | INS 172/10 | INS 172/25 | INK 205 | INK 605 | 10.0 | |
| 112 C-0-C• | | 71.4 | 25.0 | 3 | --- | INS 172/25 | INK 207 | INK 607 | 25.0 | |
| 112 D-0-H• | | 34.3 | 6.0 | 8 | --- | INS 108/06 | INK 204 | INK 604 | 6.0 | |
| 112 D-0-F• | | 45.7 | 10.0 | 6 | INS 172/10 | INS 172/25 | INK 205 | INK 605 | 10.0 | |
| 112 D-0-E• | | 51.4 | 16.0 | 4 | INS 172/16 | INS 172/25 | INK 206 | INK 606 | 16.0 | |
| 112 A-•-Z• | | surface cooling | 14.0 | 1.5 | 14 | INS 108/02 | INS 108/06 | INK 250 | INK 650 | 1.5 |
| 112 A-•-V• | | | 18.7 | 2.5 | 10 | INS 108/03 | INS 108/06 | INK 202 | INK 602 | 2.5 |
| 112 A-•-L• | 33.7 | | 6.0 | 8 | --- | INS 108/06 | INK 204 | INK 604 | 6.0 | |
| 112 B-•-P• | 26.9 | | 4.0 | 10 | INS 108/04 | INS 108/06 | INK 203 | INK 603 | 4.0 | |
| 112 B-•-L• | 35.5 | | 6.0 | 8 | --- | INS 108/06 | INK 204 | INK 604 | 6.0 | |
| 112 B-•-G• | 61.2 | | 16.0 | 4 | INS 172/16 | INS 172/25 | INK 206 | INK 606 | 16.0 | |
| 112 C-•-K• | 40.0 | | 10.0 | 6 | INS 172/10 | INS 172/25 | INK 205 | INK 605 | 10.0 | |
| 112 C-•-H• | 54.7 | | 16.0 | 4 | INS 172/16 | INS 172/25 | INK 206 | INK 606 | 16.0 | |
| 112 C-•-E• | 85.0 | | 25.0 | 3 | --- | INS 172/25 | INK 207 | INK 607 | 25.0 | |
| 112 D-•-H• | 51.4 | | 16.0 | 4 | INS 172/16 | INS 172/25 | INK 206 | INK 606 | 16.0 | |
| 112 D-•-F• | 67.8 | | 16.0 | 4 | INS 172/16 | INS 172/25 | INK 206 | INK 606 | 16.0 | |
| 112 D-•-E• | 83.3 | | 25.0 | 3 | --- | INS 172/25 | INK 207 | INK 607 | 25.0 | |

Continued on next page

- ¹⁾ Motor phase currents and connection cross sections apply to S1 continuous operation or S6 intermittent operation with those limit values (respective ON time and duty cycle time) given in the torque-speed operating curves.
- ²⁾ Minimum cross section of power connection per EN 60 204, sec. 1, table 5, cols. C or E or UL 508 table 50.2, but at least 0.75 mm² or AWG 18. Cables per UL 508 may only be soldered not crimped to the motor power connector.
- ³⁾ Data following the slash identify the type of bushing contact as either for crimping or soldering.

| Servo motor MAC ... | Cooling | Motor phase current ¹⁾ A | Power conn. Min. cross section ¹⁾ | | Motor power connector | | INDRAMAT Motor power cable | | | |
|------------------------|-----------------------|--|---|-------------------|--------------------------------|---------------------------------|-------------------------------|-------------------------|-------------------------------------|------|
| | | | mm ² | AWG ²⁾ | Crimping Type ³⁾ | Soldering type ³⁾ | w/o total shield | with total shield | cross section mm ² | |
| 115 A-0-HS | natural convection | 21.8 | 4.0 | 10 | --- | INS 172/25 | INK 203 | INK 603 | 4.0 | |
| 115 A-0-FS | | 40.0 | 10.0 | 8 | INS 172/10 | INS 172/25 | INK 205 | INK 605 | 10.0 | |
| 115 B-0-GS | | 33.5 | 6.0 | 8 | INS 172/06 | INS 172/25 | INK 204 | INK 604 | 6.0 | |
| 115 B-0-DS | | 59.0 | 16.0 | 4 | INS 172/16 | INS 172/25 | INK 206 | INK 606 | 16.0 | |
| 115 C-0-ES | | 45.1 | 10.0 | 6 | INS 172/10 | INS 172/25 | INK 205 | INK 605 | 10.0 | |
| 115 C-0-CS | | 74.6 | 25.0 | 3 | --- | INS 172/25 | INK 207 | INK 607 | 25.0 | |
| 115 D-0-ES | | 44.1 | 10.0 | 6 | INS 172/10 | INS 172/25 | INK 205 | INK 605 | 10.0 | |
| 115 D-0-DS | | 55.7 | 16.0 | 4 | INS 172/16 | INS 172/25 | INK 206 | INK 606 | 16.0 | |
| 115 D-0-CS | | 73.8 | 25.0 | 3 | --- | INS 172/25 | INK 207 | INK 607 | 25.0 | |
| 115 A--HS | | surface cooling | 40.0 | 10.0 | 8 | INS 172/10 | INS 172/25 | INK 205 | INK 605 | 10.0 |
| 115 A--FS | | | 60.0 | 16.0 | 4 | INS 172/16 | INS 172/25 | INK 206 | INK 606 | 16.0 |
| 115 B--GS | | | 54.1 | 16.0 | 6 | INS 172/16 | INS 172/25 | INK 206 | INK 606 | 16.0 |
| 115 B--DS | 89.0 | | 25.0 | 2 | --- | INS 172/25 | INK 207 | INK 607 | 25.0 | |
| 115 C--ES | 71.3 | | 25.0 | 3 | --- | INS 172/25 | INK 207 | INK 607 | 25.0 | |
| 115 D--ES | 68.6 | | 25.0 | 4 | --- | INS 172/25 | INK 207 | INK 607 | 25.0 | |
| 115 D--DS | 85.3 | | 25.0 | 2 | --- | INS 172/25 | INK 207 | INK 607 | 25.0 | |

1) Motor phase currents and connection cross sections apply to S1 continuous operation or S6 intermittent operation with those limit values (respective ON time and duty cycle time) given in the torque-speed operating curves.
2) Minimum cross section of power connection per EN 60 204, sec. 1, table 5, cols. C or E or UL 508 table 50.2, but at least 0.75 mm² or AWG 18. Cables per UL 508 may only be soldered not crimped to the motor power connector.
3) Data following the slash identify the type of bushing contact as either for crimping or soldering.

Fig 9.2: Connector to cable assignment of the power connection

9.3. Power Connector (Motor Power Connector)

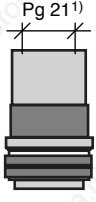
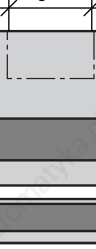
| | Crimping types | | | | | Soldering types | | | | |
|--|----------------|-----------------------------|------------------------------|--|--|-----------------|-------------------------------|---------------------------------|---|-----------------------|
| | Connector type | Maximum conn. cross section | | Strain relief ¹⁾ | | Connector type | Maximum conn. cross section | | Strain relief ¹⁾ | |
| | | Power core mm ² | Control core mm ² | Cable type INK | Mat. Nr. | | Power core | Control core ²⁾ max. | Cable type INK | Mat. Nr. |
| INS 108  | INS 108/02 | 1.5 | 1.5 | 250 650 | 225 404 225 404 | INS 108/06 | 0.75 - 6.0 mm ² | 1.5 mm ² | 253 | 260 097 |
| INS 108/03 | 2.5 | 1.5 | 202 602 | 219 857 227 526 | 250 202 203 204 653 650 602 | | | | 225 404 219 857 218 767 218 767 225 404 225 404 | |
| INS 108/04 | 4.0 | 1.5 | 203 603 | 218 767 218 767 | 602 603 604 | | | | 227 526 218 767 218 767 | |
| INS 172  | INS 172/06 | 6.0 | 1.5 | 204 604 | 220 874 ³⁾ 220 874 ³⁾ | INS 172/25 | 4.0 - 25.0 mm ² | 1.5 mm ² | 203 | 220 874 ³⁾ |
| INS 172/10 | 10.0 | 1.5 | 205 605 | 220 472 ³⁾ 221 554 ³⁾ | 204 205 206 207 603 604 605 | | | | 220 874 ³⁾ 220 472 ³⁾ 220 472 ³⁾ 220 473 220 874 ³⁾ 220 874 ³⁾ 221 554 ³⁾ | |
| INS 172/16 | 16.0 | 1.5 | 206 606 | 220 472 ³⁾ 220 473 | 605 606 607 | | | | 221 554 ³⁾ 220 473 220 473 | |

¹⁾ Strain reliefs must be mounted in the conduit thread screws of the motor power connector to ensure a problem-free operation. These are not automatically delivered. The suitable strain reliefs must be ordered from Indramat using the relevant Mat.-Nr. .

²⁾ For motor blocking brake and motor temperature monitoring.

³⁾ Further reduction requires Mat. Nr. 220 474.

Fig 9.3: Motor power connector

9.4. Motor Power Cable

9.4.1. Technical data

| Type | Power core cross section mm ² | Control core ¹⁾ cross section mm ² | Total shield | Power cable cross section mm | Minimum bending radius | | Weight kg/m |
|---------|--|--|--------------|------------------------------|------------------------|-----------------------------------|-------------|
| | | | | | fixed routing mm | flexible routing mm ²⁾ | |
| INK 253 | 1.0 | 0.5 | — | 10.3 ± 0.3 | 65 | 105 | 0.11 |
| INK 250 | 1.5 | 0.75 | — | 11.4 ± 0.4 | 90 | 140 | 0.19 |
| INK 202 | 2.5 | 1.5 | — | 17.8 ± 0.5 | 120 | 200 | 0.47 |
| INK 203 | 4.0 | 1.5 | — | 18.6 ± 0.5 | 120 | 270 | 0.57 |
| INK 204 | 6.0 | 1.5 | — | 19.8 ± 0.5 | 120 | 300 | 0.67 |
| INK 205 | 10.0 | 1.5 | — | 25.4 ± 0.7 | 200 | 380 | 1.10 |
| INK 206 | 16.0 | 1.5 | — | 26.8 ± 0.7 | 220 | 390 | 1.33 |
| INK 207 | 25.0 | 1.5 | — | 30.5 ± 0.7 | 240 | 430 | 1.70 |
| INK 653 | 1.0 | 0.75 | + | 11.5 ± 0.3 | 75 | 100 ²⁾ | 0.25 |
| INK 650 | 1.5 | 0.75 | + | 12.2 ± 0.4 | 80 | 120 ²⁾ | 0.39 |
| INK 602 | 2.5 | 0.75 | + | 14.8 ± 0.5 | 85 | 140 ²⁾ | 0.59 |
| INK 603 | 4.0 | 0.75 or 1.0 | + | 17.8 ± 0.6 | 110 | 180 ²⁾ | 0.60 |
| INK 604 | 6.0 | 0.75 or 1.0 | + | 19.8 ± 0.6 | 120 | 200 ²⁾ | 0.81 |
| INK 605 | 10.0 | 0.75 or 1.0 | + | 23.8 ± 0.6 | 150 | 240 ²⁾ | 1.10 |
| INK 606 | 16.0 | 1.0 | + | 28.2 ± 0.6 | 160 | 280 ²⁾ | 1.40 |
| INK 607 | 25.0 | 1.5 | + | 31.8 ± 0.8 | 180 | 300 ²⁾ | 1.73 |

1) For motor blocking brake and motor temperature monitoring.
2) Service life equals 1 000 000 bending loads

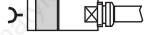

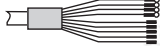
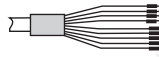

Fig 9.4: Type code dependent data of the motor power cable

9.4.2. General data



| Designation | Data |
|---|--|
| Prot. cat. transition cable to connector | IP 65 |
| Chemical features | absolute resistance to mineral oils and greases, hydrolysis resistant, silicone and halogen free |
| Permissible ambient temperature range for operation and storage | -30 to + 80 °C |
| Cable surface | poor adhesion, prevents sticking in drag chains |
| Cable length | maximum 75 meters |

Fig 9.5: General data of the motor power cable

9.4.3. Ready-Made Motor Power Cables

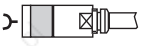
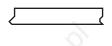
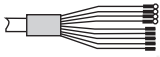
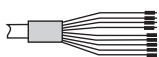
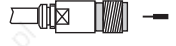

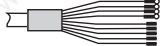
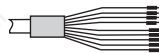
| Servo motor MAC ... | Cooling of the motor | Motor power connector  | Motor power cable Type mm ²  | | Cable ends for ... | | | |
|--|----------------------------|---|--|---------|--|--|---|---------|
| | | | | | Direct connection to drives  | Intermediate terminals to terminal strip  | Intermediate plug- in connection with coupling ¹⁾  | |
| 063 A-0-ES | natural convection | INS 108/06 | INK 253 | 0.75 | IK• 011 | IK• 012 | IK• 003 | |
| 063 A-0-RS | | INS 108/06 | INK 253 | 0.75 | IK• 011 | IK• 012 | IK• 003 | |
| 063 B-0-GS | | INS 108/06 | INK 253 | 0.75 | IK• 011 | IK• 012 | IK• 003 | |
| 063 B-0-JS | | INS 108/06 | INK 253 | 0.75 | IK• 011 | IK• 012 | IK• 003 | |
| 063 C-0-MS | | INS 108/06 | INK 253 | 0.75 | IK• 011 | IK• 012 | IK• 003 | |
| 063 C-0-HS | | INS 108/06 | INK 253 | 0.75 | IK• 011 | IK• 012 | IK• 003 | |
| 063 D-0-JS | | INS 108/06 | INK 253 | 0.75 | IK• 011 | IK• 012 | IK• 003 | |
| 063 D-0-FS | | INS 108/06 | INK 253 | 0.75 | IK• 011 | IK• 012 | IK• 003 | |
| 063 A-•-ES | | surface cooling | INS 108/06 | INK 253 | 0.75 | IK• 011 | IK• 012 | IK• 003 |
| 063 A-•-RS | | | INS 108/06 | INK 253 | 0.75 | IK• 011 | IK• 012 | IK• 003 |
| 063 B-•-GS | | | INS 108/06 | INK 253 | 0.75 | IK• 011 | IK• 012 | IK• 003 |
| 063 B-•-JS | | | INS 108/06 | INK 253 | 0.75 | IK• 011 | IK• 012 | IK• 003 |
| 063 C-•-MS | INS 108/06 | | INK 253 | 0.75 | IK• 011 | IK• 012 | IK• 003 | |
| 063 C-•-HS | INS 108/06 | | INK 253 | 0.75 | IK• 011 | IK• 012 | IK• 003 | |
| 063 D-•-JS | INS 108/06 | | INK 253 | 0.75 | IK• 011 | IK• 012 | IK• 003 | |
| 063 D-•-FS | INS 108/06 | | INK 253 | 0.75 | IK• 011 | IK• 012 | IK• 003 | |
| Continued on next page | | | | | | | | |
| 1) For coupling suitable mate: motor power connector | | | | | | | | |

| Servo motor MAC ... | Cooling of the motor | Motor power connector  | Motor power cable Type mm ²  | | Cable ends for ... | | | |
|--|----------------------------|---|--|---------|---|--|---|---------|
| | | | | | Direct connection to drives  | Intermediate terminals to terminal strip  | Intermediate plug- in connection with coupling ¹⁾  | |
| 071 A-0-HS | natural convection | INS 108/06 | INK 253 | 0.75 | IK• 011 | IK• 012 | IK• 003 | |
| 071 A-0-OS | | INS 108/06 | INK 253 | 0.75 | IK• 011 | IK• 012 | IK• 003 | |
| 071 A-0-ES | | INS 108/06 | INK 253 | 0.75 | IK• 011 | IK• 012 | IK• 003 | |
| 071 A-0-VS | | INS 108/06 | INK 253 | 0.75 | IK• 011 | IK• 012 | IK• 003 | |
| 071 B-0-FS | | INS 108/06 | INK 253 | 0.75 | IK• 011 | IK• 012 | IK• 003 | |
| 071 B-0-TS | | INS 108/06 | INK 253 | 0.75 | IK• 011 | IK• 012 | IK• 003 | |
| 071 B-0-PS | | INS 108/06 | INK 253 | 0.75 | IK• 011 | IK• 012 | IK• 003 | |
| 071 B-0-KS | | INS 108/02 | INK 250 | 1.5 | IK• 021 | IK• 022 | IK• 023 | |
| 071 C-0-US | | INS 108/06 | INK 253 | 0.75 | IK• 011 | IK• 012 | IK• 003 | |
| 071 C-0-NS | | INS 108/06 | INK 253 | 0.75 | IK• 011 | IK• 012 | IK• 003 | |
| 071 C-0-JS | | INS 108/02 | INK 250 | 1.5 | IK• 021 | IK• 022 | IK• 023 | |
| 071 C-0-GS | | INS 108/03 | INK 202 | 2.5 | IK• 041 | IK• 042 | IK• 043 | |
| 071 A--HS | | surface cooling | INS 108/06 | INK 253 | 0.75 | IK• 011 | IK• 012 | IK• 003 |
| 071 A--OS | | | INS 108/06 | INK 253 | 0.75 | IK• 011 | IK• 012 | IK• 003 |
| 071 A--ES | | | INS 108/06 | INK 253 | 0.75 | IK• 011 | IK• 012 | IK• 003 |
| 071 A--VS | | | INS 108/02 | INK 250 | 1.5 | IK• 021 | IK• 022 | IK• 023 |
| 071 B--FS | INS 108/06 | | INK 253 | 0.75 | IK• 011 | IK• 012 | IK• 003 | |
| 071 B--TS | INS 108/02 | | INK 250 | 1.5 | IK• 021 | IK• 022 | IK• 023 | |
| 071 B--PS | INS 108/02 | | INK 250 | 1.5 | IK• 021 | IK• 022 | IK• 023 | |
| 071 B--KS | INS 108/03 | | INK 202 | 2.5 | IK• 041 | IK• 042 | IK• 043 | |
| 071 C--US | INS 108/02 | | INK 250 | 1.5 | IK• 021 | IK• 022 | IK• 023 | |
| 071 C--NS | INS 108/03 | | INK 202 | 2.5 | IK• 041 | IK• 042 | IK• 043 | |
| 071 C--JS | INS 108/04 | | INK 203 | 4.0 | IK• 061 | IK• 062 | IK• 063 | |
| 071 C--GS | INS 108/06 | | INK 204 | 6.0 | IK• 081 | IK• 082 | IK• 089 | |
| Continued on next page | | | | | | | | |
| 1) For coupling suitable mate: motor power connector | | | | | | | | |

| Servo motor MAC ... | Cooling of the motor | Motor power connector  | Motor power cable | | Cable ends for ... | | |
|--|----------------------------|---|----------------------|-----------------|--|--|---|
| | | | Type | mm ² | Direct connection to drives  | Intermediate terminals to terminal strip  | Intermediate plug- in connection with coupling ¹⁾  |
| 090 A-0-Z• | natural convection | INS 108/06 | INK 253 | 0,75 | IK• 011 | IK• 012 | IK• 003 |
| 090 A-0-R• | | INS 108/02 | INK 250 | 1,5 | IK• 021 | IK• 022 | IK• 023 |
| 090 B-0-P• | | INS 108/02 | INK 250 | 1,5 | IK• 021 | IK• 022 | IK• 023 |
| 090 B-0-N• | | INS 108/02 | INK 250 | 1,5 | IK• 021 | IK• 022 | IK• 023 |
| 090 B-0-J• | | INS 108/02 | INK 250 | 1,5 | IK• 021 | IK• 022 | IK• 023 |
| 090 C-0-K• | | INS 108/02 | INK 250 | 1,5 | IK• 021 | IK• 022 | IK• 023 |
| 090 C-0-G• | | INS 108/03 | INK 202 | 2,5 | IK• 041 | IK• 042 | IK• 043 |
| 090 C-0-E• | | INS 108/06 | INK 204 | 6,0 | IK• 081 | IK• 082 | IK• 089 |
| 090 A--Z• | | surface cooling | INS 108/06 | INK 253 | 0,75 | IK• 011 | IK• 012 |
| 090 A--R• | INS 108/02 | | INK 250 | 1,5 | IK• 021 | IK• 022 | IK• 023 |
| 090 B--P• | INS 108/02 | | INK 250 | 1,5 | IK• 021 | IK• 022 | IK• 023 |
| 090 B--N• | INS 108/03 | | INK 202 | 2,5 | IK• 041 | IK• 042 | IK• 043 |
| 090 B--J• | INS 108/04 | | INK 203 | 4,0 | IK• 061 | IK• 062 | IK• 063 |
| 090 C--K• | INS 108/04 | | INK 203 | 4,0 | IK• 061 | IK• 062 | IK• 063 |
| 090 C--G• | INS 108/06 | | INK 204 | 6,0 | IK• 081 | IK• 082 | IK• 089 |
| 090 C--E• | INS 172/10 | | INK 205 | 10,0 | IK• 121 | IK• 122 | IK• 128 |
| Continued on next page | | | | | | | |
| 1) For coupling suitable mate: motor power connector | | | | | | | |

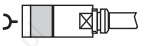
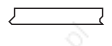
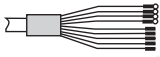
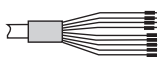
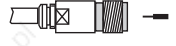

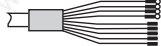
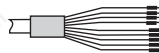
9. Electrical Power Connection

| Servo motor MAC ... | Cooling of the motor | Motor power connector  | Motor power cable Type mm ²  | | Cable ends for ... | | | |
|--|----------------------------|---|--|---------|---|--|---|---------|
| | | | | | Direct connection to drives  | Intermediate terminals to terminal strip  | Intermediate plug- in connection with coupling ¹⁾  | |
| 093 A-0-WS | natural convection | INS 108/02 | INK 250 | 1,5 | IK• 021 | IK• 022 | IK• 023 | |
| 093 A-0-PS | | INS 108/02 | INK 250 | 1,5 | IK• 021 | IK• 022 | IK• 023 | |
| 093 A-0-LS | | INS 108/03 | INK 202 | 2,5 | IK• 041 | IK• 042 | IK• 043 | |
| 093 A-0-HS | | INS 108/04 | INK 203 | 4,0 | IK• 061 | IK• 062 | IK• 063 | |
| 093 B-0-OS | | INS 108/02 | INK 250 | 1,5 | IK• 021 | IK• 022 | IK• 023 | |
| 093 B-0-JS | | INS 108/04 | INK 203 | 4,0 | IK• 061 | IK• 062 | IK• 063 | |
| 093 B-0-GS | | INS 172/06 | INK 204 | 6,0 | IK• 101 | IK• 102 | IK• 108 | |
| 093 B-0-ES | | INS 172/10 | INK 205 | 10,0 | IK• 121 | IK• 122 | IK• 128 | |
| 093 C-0-KS | | INS 108/03 | INK 202 | 2,5 | IK• 041 | IK• 042 | IK• 043 | |
| 093 C-0-FS | | INS 172/06 | INK 204 | 6,0 | IK• 101 | IK• 102 | IK• 108 | |
| 093 C-0-DS | | INS 172/10 | INK 205 | 10,0 | IK• 121 | IK• 122 | IK• 128 | |
| 093 C-0-CS | | INS 172/10 | INK 205 | 10,0 | IK• 121 | IK• 122 | IK• 128 | |
| 093 A--WS | | surface cooling | INS 108/02 | INK 250 | 1,5 | IK• 021 | IK• 022 | IK• 023 |
| 093 A--PS | | | INS 108/03 | INK 202 | 2,5 | IK• 041 | IK• 042 | IK• 043 |
| 093 A--LS | | | INS 108/04 | INK 203 | 4,0 | IK• 061 | IK• 062 | IK• 063 |
| 093 A--HS | | | INS 108/04 | INK 203 | 4,0 | IK• 061 | IK• 062 | IK• 063 |
| 093 B--OS | INS 108/03 | | INK 202 | 2,5 | IK• 041 | IK• 042 | IK• 043 | |
| 093 B--JS | INS 108/04 | | INK 203 | 4,0 | IK• 061 | IK• 062 | IK• 063 | |
| 093 B--GS | INS 172/10 | | INK 205 | 10,0 | IK• 121 | IK• 122 | IK• 128 | |
| 093 B--ES | INS 172/16 | | INK 206 | 16,0 | IK• 141 | IK• 142 | IK• 148 | |
| 093 C--KS | INS 108/04 | | INK 203 | 4,0 | IK• 061 | IK• 062 | IK• 063 | |
| 093 C--FS | INS 172/10 | | INK 205 | 10,0 | IK• 121 | IK• 122 | IK• 128 | |
| 093 C--DS | INS 172/16 | | INK 206 | 16,0 | IK• 141 | IK• 142 | IK• 148 | |
| 093 C--CS | INS 172/25 | | INK 207 | 25,0 | IK• 161 | IK• 162 | IK• 168 | |
| Continued on next page | | | | | | | | |
| 1) For coupling suitable mate: motor power connector | | | | | | | | |

| Servo motor MAC ... | Cooling of the motor | Motor power connector  | Motor power cable | | Cable ends for ... | | | |
|------------------------|----------------------------|---|----------------------|-----------------|--|--|---|---------|
| | | | Type | mm ² | Direct connection to drives  | Intermediate terminals to terminal strip  | Intermediate plug- in connection with coupling ¹⁾  | |
| 112 A-0-Z• | natural convection | INS 108/02 | INK 250 | 1,5 | IK• 021 | IK• 022 | IK• 023 | |
| 112 A-0-V• | | INS 108/02 | INK 250 | 1,5 | IK• 021 | IK• 022 | IK• 023 | |
| 112 A-0-L• | | INS 108/04 | INK 203 | 4,0 | IK• 061 | IK• 062 | IK• 063 | |
| 112 B-0-P• | | INS 108/03 | INK 202 | 2,5 | IK• 041 | IK• 042 | IK• 043 | |
| 112 B-0-L• | | INS 108/04 | INK 203 | 4,0 | IK• 061 | IK• 062 | IK• 063 | |
| 112 B-0-G• | | INS 108/06 | INK 204 | 6,0 | IK• 081 | IK• 082 | IK• 089 | |
| 112 C-0-K• | | INS 108/04 | INK 203 | 4,0 | IK• 061 | IK• 062 | IK• 063 | |
| 112 C-0-H• | | INS 108/06 | INK 204 | 6,0 | IK• 081 | IK• 082 | IK• 089 | |
| 112 C-0-E• | | INS 172/10 | INK 205 | 10,0 | IK• 121 | IK• 122 | IK• 128 | |
| 112 C-0-C• | | INS 172/25 | INK 207 | 25,0 | IK• 161 | IK• 162 | IK• 168 | |
| 112 D-0-H• | | INS 108/06 | INK 204 | 6,0 | IK• 081 | IK• 082 | IK• 089 | |
| 112 D-0-F• | | INS 172/10 | INK 205 | 10,0 | IK• 121 | IK• 122 | IK• 128 | |
| 112 D-0-E• | | INS 172/16 | INK 206 | 16,0 | IK• 141 | IK• 142 | IK• 148 | |
| 112 A--Z• | | surface cooling | INS 108/02 | INK 250 | 1,5 | IK• 021 | IK• 022 | IK• 023 |
| 112 A--V• | | | INS 108/03 | INK 202 | 2,5 | IK• 041 | IK• 042 | IK• 043 |
| 112 A--L• | INS 108/06 | | INK 204 | 6,0 | IK• 081 | IK• 082 | IK• 089 | |
| 112 B--P• | INS 172/25 | | INK 203 | 4,0 | IK• 061 | IK• 062 | IK• 063 | |
| 112 B--L• | INS 108/06 | | INK 204 | 6,0 | IK• 081 | IK• 082 | IK• 089 | |
| 112 B--G• | INS 172/16 | | INK 206 | 16,0 | IK• 141 | IK• 142 | IK• 148 | |
| 112 C--K• | INS 172/10 | | INK 205 | 10,0 | IK• 121 | IK• 122 | IK• 128 | |
| 112 C--H• | INS 172/16 | | INK 206 | 16,0 | IK• 141 | IK• 142 | IK• 148 | |
| 112 C--E• | INS 172/25 | | INK 207 | 25,0 | IK• 161 | IK• 162 | IK• 168 | |
| 112 D--H• | INS 172/16 | | INK 206 | 16,0 | IK• 141 | IK• 142 | IK• 148 | |
| 112 D--F• | INS 172/16 | | INK 206 | 16,0 | IK• 141 | IK• 142 | IK• 148 | |
| 112 D--E• | INS 172/25 | | INK 207 | 25,0 | IK• 161 | IK• 162 | IK• 168 | |

Continued on next page

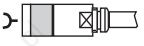
¹⁾ For coupling suitable mate: motor power connector

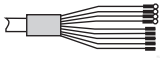
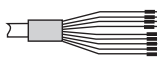
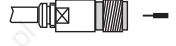
| Servo motor MAC ... | Cooling of the motor | Motor power connector  | Motor power cable Type mm ²  | | Cable ends for ... | | | |
|------------------------|----------------------------|---|--|---------|---|--|---|---------|
| | | | | | Direct connection to drives  | Intermediate terminals to terminal strip  | Intermediate plug- in connection with coupling ¹⁾  | |
| 115 A-0-HS | natural convection | INS 172/06 | INK 204 | 6,0 | IK• 101 | IK• 102 | IK• 108 | |
| 115 A-0-FS | | INS 172/10 | INK 205 | 10,0 | IK• 121 | IK• 122 | IK• 128 | |
| 115 B-0-GS | | INS 172/06 | INK 204 | 6,0 | IK• 101 | IK• 102 | IK• 108 | |
| 115 B-0-DS | | INS 172/16 | INK 206 | 16,0 | IK• 141 | IK• 142 | IK• 148 | |
| 115 C-0-ES | | INS 172/10 | INK 205 | 10,0 | IK• 121 | IK• 122 | IK• 128 | |
| 115 C-0-CS | | INS 172/25 | INK 207 | 25,0 | IK• 161 | IK• 162 | IK• 168 | |
| 115 D-0-ES | | INS 172/10 | INK 205 | 10,0 | IK• 121 | IK• 122 | IK• 128 | |
| 115 D-0-DS | | INS 172/16 | INK 206 | 16,0 | IK• 141 | IK• 142 | IK• 148 | |
| 115 D-0-CS | | INS 172/25 | INK 207 | 25,0 | IK• 161 | IK• 162 | IK• 168 | |
| 115 A--HS | | surface cooling | INS 172/10 | INK 205 | 10,0 | IK• 121 | IK• 122 | IK• 128 |
| 115 A--FS | | | INS 172/16 | INK 206 | 16,0 | IK• 141 | IK• 142 | IK• 148 |
| 115 B--GS | | | INS 172/16 | INK 206 | 16,0 | IK• 141 | IK• 142 | IK• 148 |
| 115 B--DS | INS 172/25 | | INK 207 | 25,0 | IK• 161 | IK• 162 | IK• 168 | |
| 115 C--ES | INS 172/25 | | INK 207 | 25,0 | IK• 161 | IK• 162 | IK• 168 | |
| 115 D--ES | INS 172/25 | | INK 207 | 25,0 | IK• 161 | IK• 162 | IK• 168 | |
| 115 D--DS | INS 172/25 | | INK 207 | 25,0 | IK• 161 | IK• 162 | IK• 168 | |

¹⁾ For coupling suitable mate: motor power connector

Fig 9.6: Types of ready-made motor power cable differentiated by cable end

9.4.4. Order guidelines

Example: IKL 041 / 12.0

Length in meters

L... Standard cable without total shield

G... Cable with total shield

The cable are available in 0.5 meter increments from a length of 5 meters. Shorter lengths available upon request.

10. Electrical Connection Tachofeedback

10.1. Terminal Diagram

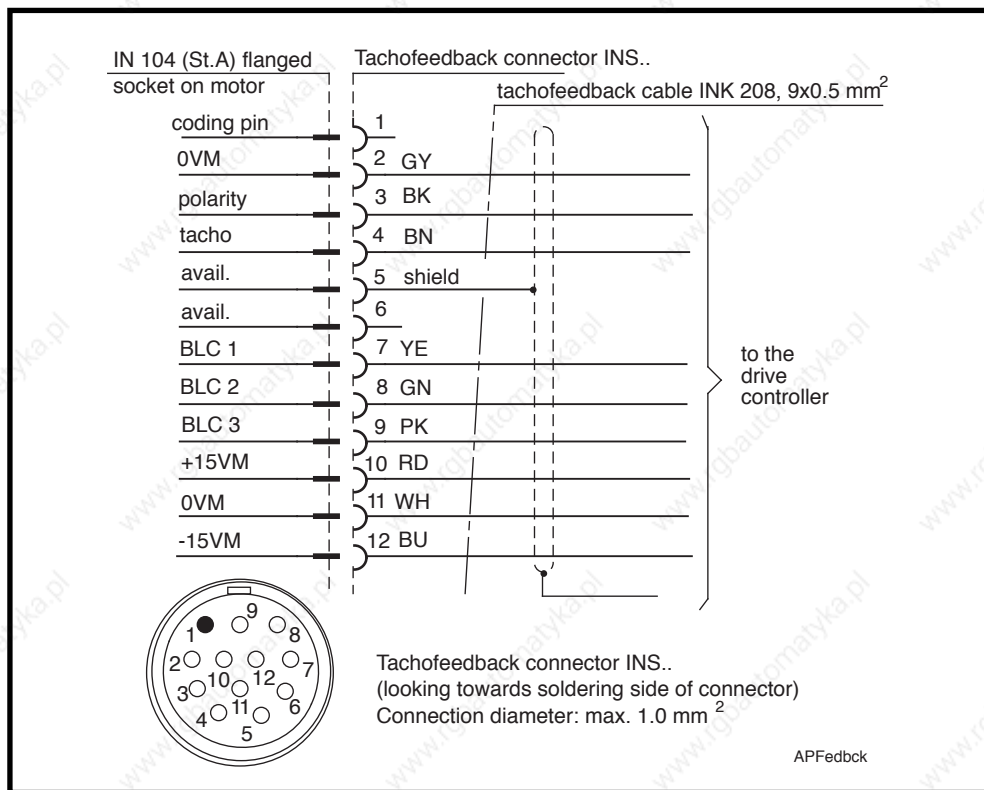

Fig 10.1: Tachofeedback connection

10.2. Tachofeedback Connector

| Motor type MAC... | Types of connectors for INDRAMAT cable INK 208 | | Connector types suitable for cable with external diameter ... | |
|--|--|---------------------------|---|---------------------------------------|
| | straight connector | angle connector | (...6.5 - 9.5 mm) straight connector | (...7.0 - 10.5 mm) angle connector |
| 063... | INS 302 | — | INS 102 | — |
| 071... ¹⁾ 090... ¹⁾ 093... ¹⁾ 112... ²⁾ 115... ²⁾ | INS 302 | INS 352 ³⁾ | INS 102 | INS 312 ³⁾ |

¹⁾ With axial surface cooling, use straight connectors only.
²⁾ With axial surface cooling, use straight connectors with extension sleeves only (part no. 218277).
³⁾ Do not use with MAC 093 in connection with power connector INS 172, if power connector mounted towards side B.

Fig 10.2: Available tachofeedback connectors











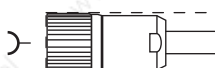

10.3. Tachofeedback Cable

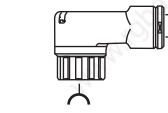
10.3.1. Technical Data

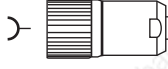
| | |
|---|--|
| Type designation | INK 208 |
| Prot. cat. transition cable to conn. | IP 65 |
| Cable diameter | 8.8 ± 0.3 mm |
| Minimum bending radius fixed routing | 40 mm |
| Minimum bending radius flexible routing (Service life equals 1,000,000 bend loads) | 90 mm |
| Weight | 0.103 kg/m |
| Permissible ambient temperature for operation and storage | -30 °C to +80 °C |
| Cable surface | adhesion poor, prevents sticking in drag chains |
| Chemical characteristics | absolute resistance to mineral oils and greases, hydrolysis resistant, silicone and halogen free |
| Maximum cable length | 75 m |

Fig 10.3: Technical data tachofeedback cable INK 208

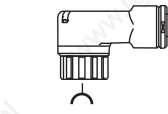
10.3.2. Ready-Made Tachofeedback Cable

| Order codes for ready-made tachofeedback cable | Type codes of tachofeedback connector | INDRAMAT tachofeedback cable | Type of cable end |
|--|--|------------------------------|---|
| IKS 255 | INS 302  | INK 208 | INS 317  |
| IKS 256 ¹⁾ | INS 302 with extension sleeve  | INK 208 | INS 317  with coupling unit for connecting matching mate INS 302 |
| IKS 261 ^{2) 3)} | INS 352  | INK 208 | INS 317  |
| IKS 251 | INS 302  | INK 208 |  |
| IKS 252 ¹⁾ | INS 302 with extension sleeve  | INK 208 |  with ferrules for connecting to terminal strip of drive controller |
| IKS 259 ^{2) 3)} | INS 352  | INK 208 |  |

¹⁾ with MAC 112 and 115 with axial surface cooling
²⁾ do not use in motors with axial surface cooling
³⁾ do not use in MAC 093 together with INS 172 and mounting orientation side B

MZFEEDBACK

Fig 10.4: Ready-made feedback cable

10.3.3. Order guidelines

Example: IKS 255 / 12.0

length in meters

The ready-made cables are available in increments of 0.5 meters from five meters. Shorter lengths available upon request.

11. Electrical Connection Incremental Encoder

11.1. Terminal Diagram

Encoder with square-wave pulse

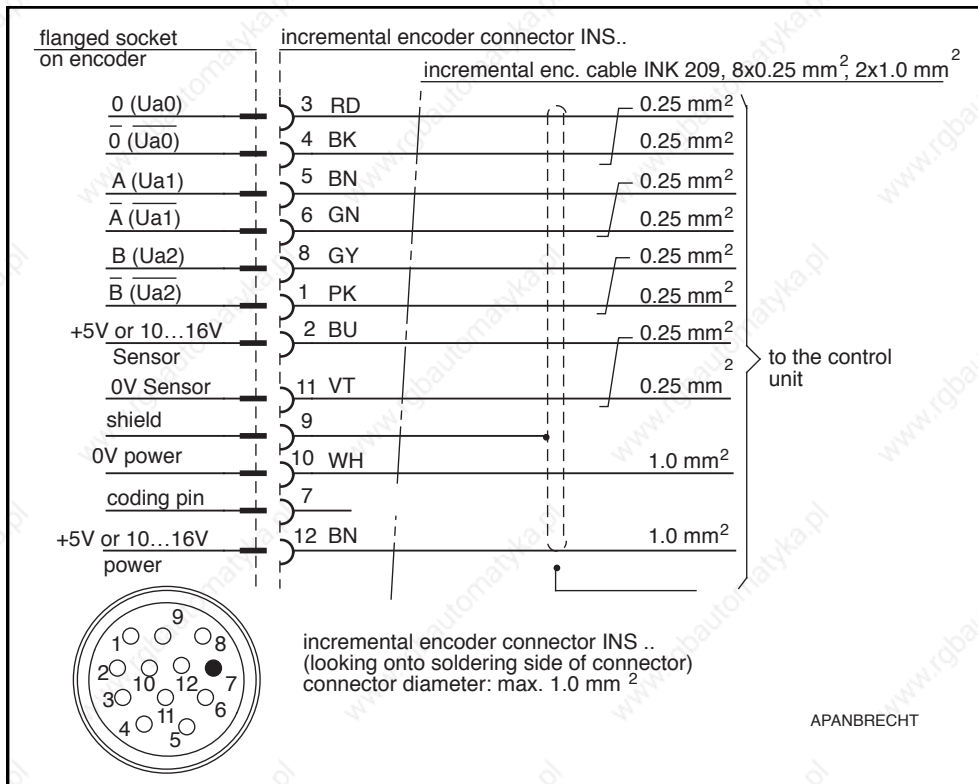

Fig 11.1: Incremental encoder terminal diagram - 5V and 10-16V, square-wave pulse

Encoder with sinusoidal signal

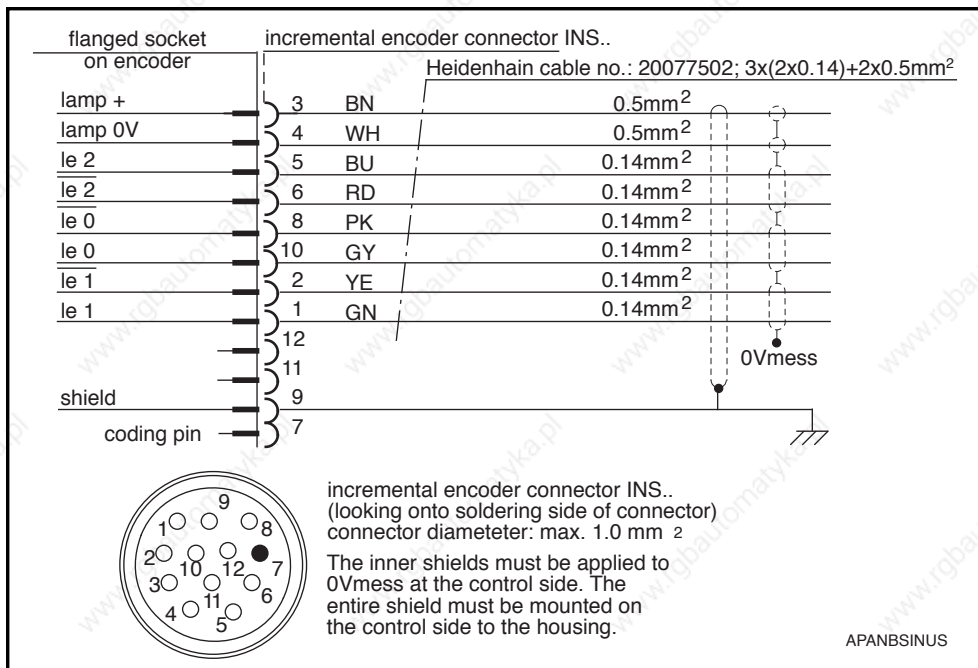

Fig 11.2: Incremental encoder - terminal diagram - sinus signals

11.2. Incremental Encoder Connector





| Mototyp MAC... | Types of connectors for INDRAMAT cable INK 209 | | Connector types suitable for Heidenhain cable or cable with external diameter ... | |
|--|--|--|---|--|
| | straight connector | angle connector | (...6.5 - 9.5 mm) straight connector | (...7.0 - 10.5 mm) angle connector |
| 063... 071... ¹⁾ 090... ¹⁾ 093... ¹⁾ 112... ²⁾ 115... ²⁾ | INS 301  | INS 351  | INS 101  | INS 311  |
| ¹⁾ With axial surface cooling use straight connector only. ²⁾ With axial surface cooling use straight connector with extension sleeve only (part no. 218277). | | | | |

Fig 11.3: Available incremental encoder connectors

11.3. Incremental Encoder Cable

11.3.1. Technical Data

INDRAMAT cable



| | |
|---|---|
| Type designation | INK 209 |
| Prot. cat. transition cable to conn. | IP 65 |
| Cable diameter | 8.8 ± 0.3 mm |
| Minimum bending radius fixed routing | 40 mm |
| Minimum bending radius flexible routing (Service life equals 1,000,000 bend loads) | 90 mm |
| Weight | 0.102 kg/m |
| Permissible ambient temperature for operation and storage | -30 °C to +80 °C |
| Cable surface | adhesion poor, prevents sticking in drag chains |
| Chemical characteristics | resistant to mineral oils and greases, hydrolysis resistant, silicone and halogen free |
| Maximum cable length | 50 m |

Fig 11.4: Technical data - incremental encoder cable - INK 209

Heidenhain cable

For technical data on the Heidenhain cable, please see the Heidenhain documentation. Maximum cable length equals 50 meters.

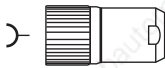
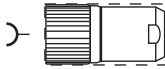
11.3.2. Ready-Made Incremental Encoder Cable for Encoders with Square-Wave Pulses

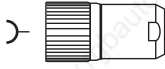
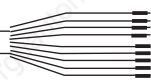
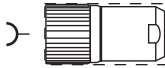
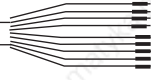
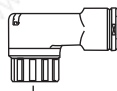
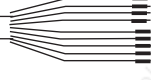
| Order code for ready-made incremental encoder cables | Type codes for incremental encoder connectors | INDRAMAT incremental encoder cable | Type of cable end |
|--|--|------------------------------------|--|
| IKS 303 |  | INK 209 | INS 318 |
| IKS 304 ¹⁾ | INS 301 with extension sleeve  | INK 209 | INS 318 with coupling unit to connect matching connector INS 301 |
| IKS 309 ²⁾ | INS 351  | INK 209 | INS 318 |
| IKS 301 | INS 301  | INK 209 |  |
| IKS 302 ¹⁾ | INS 301 with extension sleeve  | INK 209 |  with ferrules for connecting to terminal strip ³⁾ |
| IKS 307 ²⁾ | INS 351  | INK 209 |  |

¹⁾ in MAC 112 and 115 with axial surface cooling
²⁾ do not use in motors with axial surface cooling
³⁾ avoid because of interference in shield

KonfiNK

Fig 11.5: Ready-made incremental encoder cable for encoders with square-wave pulses

11.3.3. Order guidelines

Example : IKS 301 / 12.0

Length in meters

The ready-made cables are available in increments of 0.5 meters from five meters. Shorter lengths available upon request.

12. Electrical Connection Absolute Encoder

12.1. Terminal Diagram

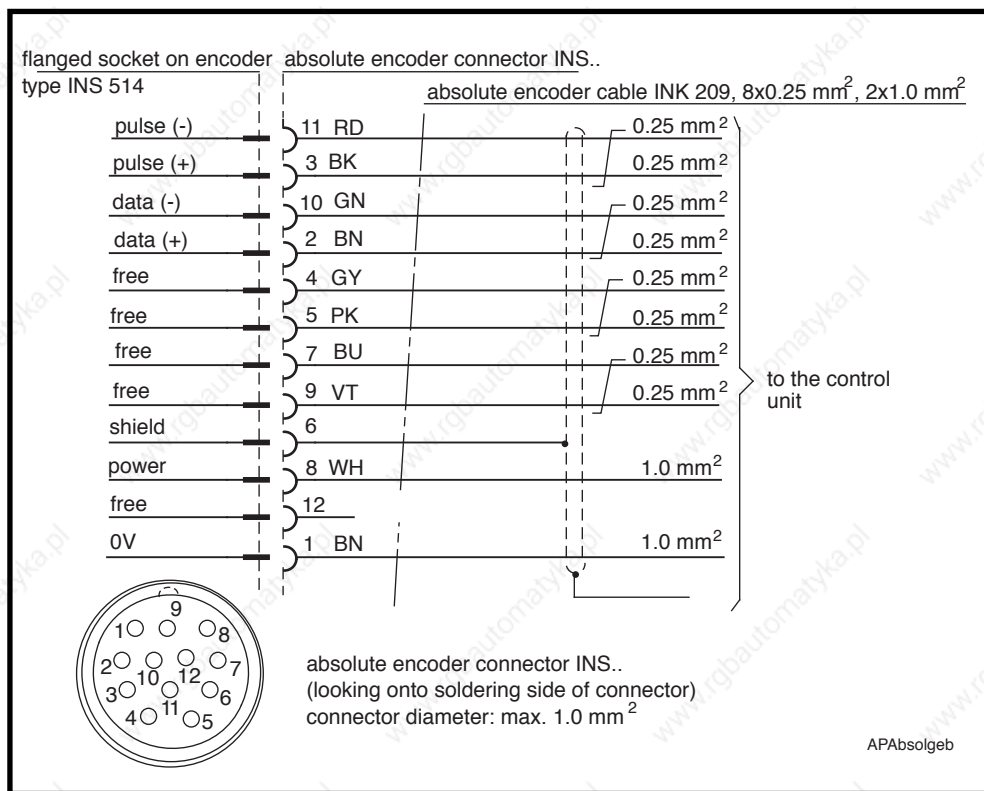

Fig 12.1: Terminal diagram - absolute encoder

12.2. Absolute Encoder Connector

| Motor type MAC... | Types of connectors for INDRAMAT cable INK 209 | | Connector types suitable for cable with external diameter of 6.5 - 9.5 mm |
|--|--|-----------------|---|
| | straight connector | angle connector | straight connector |
| 063... 071... ¹⁾ 090... ¹⁾ 093... ¹⁾ 112... ¹⁾ 115... ¹⁾ | INS 326 | INS 322 | INS 092 |
| ¹⁾ Can be used with axial surface cooling straight connector. | | | |

Fig 12.2: Available absolute encoder connectors





12.3. Absolute Encoder Cable

12.3.1. Technical Data

| | |
|---|--|
| Type designation | INK 209 |
| Prot. cat. transition cable to connector | IP 65 |
| Cable cross section | 8.8 ± 0.3 mm |
| Minimum bending radius fixed routing | 40 mm |
| Minimum bending radius flexible routing (Service life equals 1,000,000 bend loads) | 90 mm |
| Weight | 0.102 kg/m |
| Permissible ambient temperature for operation and storage | -30 °C to +80 °C |
| Cable surface | adhesion poor, prevents sticking in drag chains |
| Chemical characteristics | resistant to mineral oils and greases, hydrolysis resistant, silicone and halogen free |
| Maximum cable length | 100 m |

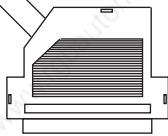
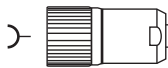
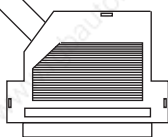
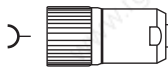
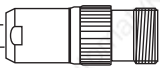
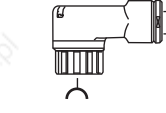
Fig 12.3: Technical data absolute encoder cable INK 209

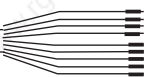
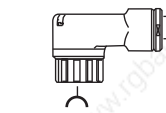
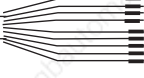
12.3.2. Ready-Made Absolute Encoder Cables

| Order code for ready-made absolute encoder cable | Type code of absolute encoder connector | INDRAMAT absolute encoder cable | Type of cable end |
|--|--|---------------------------------|--|
| IKS 724 | INS 326  | INK 209 | INS 292  |
| | INS 322  | INK 209 | INS 292  plug-in connector 25-pin D-Sub to connect to CLM |
| IKS 806 | INS 326  | INK 209 | INS 327  |
| | INS 322  | INK 209 | INS 327  with coupling unit for connecting to matching connector INS 326 |
| IKS 801 | INS 326  | INK 209 |  |
| | INS 322  | INK 209 |  with ferrules to connect to terminal strip ²⁾ |
| IKS 805 ¹⁾ | INS 326  | INK 209 |  |
| | INS 322 | INK 209 | |

¹⁾ do not use in motors with axial surface cooling
²⁾ avoid due to interference in shield

MZFEEDBACK

Fig 12.4: Ready-made absolute encoder cables

12.3.3. Order guidelines

Example : IKS 801 / 12.0

Length in meters

The ready-made cables are available in increments of 0.5 meters from five meters. Shorter lengths available upon request.

13. Guidelines on Routing Encoder Cables

Past experiences in the industry have shown that the design of an installation can be of significant importance for the interference-free transmission of encoder signals. The following should be noted with respect to the routing of the cables:

- Route the cables with shielding and separately of the load voltage lines and mains control lines.
- If the encoder cables are routed parallel to the motor cables, then maintain a minimum distance of 100 mm or equip with a metallic partition to the service cable.
- The shield of the encoder cable should be applied to the NC in the encoder connector.
- The shield may not be applied on the housing but on the motor. The encoders are insulated against the servo motor. This prevents earth loops.
- Neither pull out nor insert the connector while voltage is being applied.

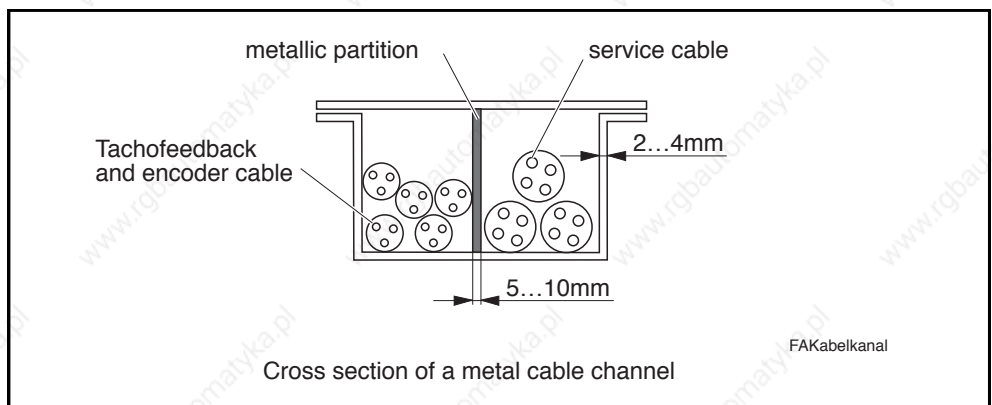

Fig 13.1: Example of a metallic partition of the control cables to prevent interference from power cables.

14. Condition at Delivery

The motors are packed onto a palette or in cartons at the time of delivery. The way they are packed depends upon the numbers and/or sizes of the motor.

If a single motor is packed on a palette, then it is secured against sliding and movement by means of a squared timbers, and then tightly lashed into place with taut metal bands. If several motors are simultaneously delivered, then up to three motors will be on one palette. Pieces of styrofoam or cartons are then used to prevent them from damaging each other.

To prevent damage from inclement weather, a carton is palced over a palette and then affixed to the palette with the use of taut bands.

To unpack without damaging the items, simply cut through the taut bands.



Caution! There is tension in the taut bands!

There exists the danger of injury from uncontrolled lashing out of the taut bands!

Maintain sufficient distance! Cut taught bands open carefully!

There is an envelope containing the delivery slip attached to the carton.

There is also a barcode sticker, or stickers depending on the extent of the delivery, listing the following information:

- type designation of the motor
- customer
- delivery slip number
- consignment
- name of delivering agent

For additional information, please see section 15, "Identifying the Merchandise".

There is no further documentation accompanying the delivery unless specifically requested.

15. Identifying the Merchandise

Only one delivery slip accompanies the entire delivery. This slip lists the merchandise in terms of its name and order designations. In the event that some of the listed items are distributed over several cartons or transport containers, then this will be noted in the delivery or freight slip.

Barcode Sticker There is a barcode sticker on the packaging of the motor. If several motors are in one carton or container, then there is a sticker for each motor.

The sticker helps to identify the contents of the cartons and is required to complete the order procedure at Indramat.

The following information is on the sticker:

- type designation of the motor
- customer
- delivery slip number
- consignment
- name of the delivering agent



Fig 15.1: An example of a barcode sticker

Rating Plate The motor is delivered with a rating plate which is attached to the motor housing.

If a second rating plate is ordered, then it is placed over the original one with double-sided tape. Both are on the housing of the motor.

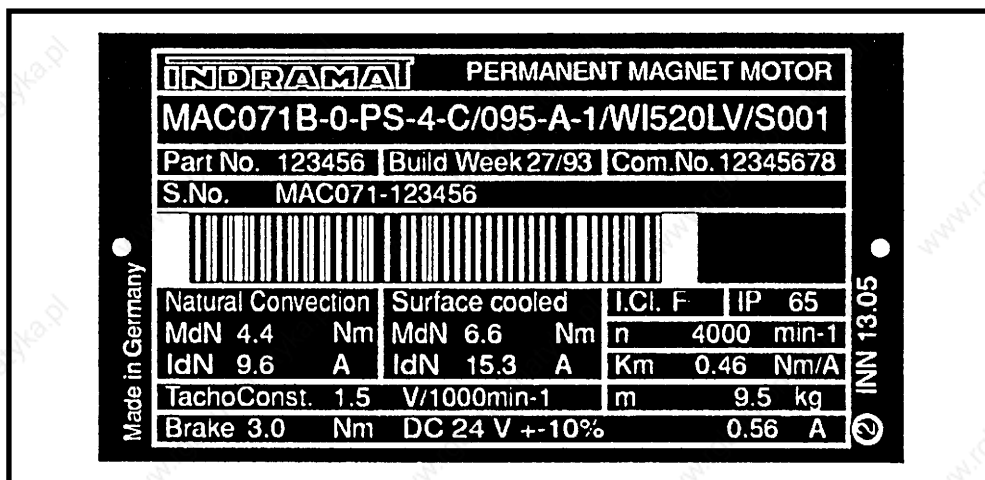

Fig 15.2: Example of a rating plate of a MAC AC servo motor per DIN 42961

16. Storage, Transport and Handling

There are guidelines on storage and transportation printed on the carton. These must be followed.



Fig 16.1: Guidelines on storage and transport on packaging

Storing the Motors

The motors must be stored in a dry, dust-free and shock-free environment.

Permissible ambient temperature range: -25 °C to + 85 °C.

There are protective covers on the connector housing as well as the output shaft. These are made of plastic and protect the parts they cover against moisture and damage. Do not remove the protective covers until shortly prior to mounting into the machine.

Transport and Handling

Avoid impacts to the output shaft and heavy loads as otherwise the bearings in the motor could be damaged.

Note the different weights and sizes of the individual types of motors when selecting both the transport and lifting devices.



Do not pick up the motor at the blower. This will damage and possibly tear the blower off of the motor housing.

Figure 16.2 depicts how the heavy motors should be picked up with the help of a crane and belts. It is important that no load be applied to either output shaft or blower housing during this procedure!

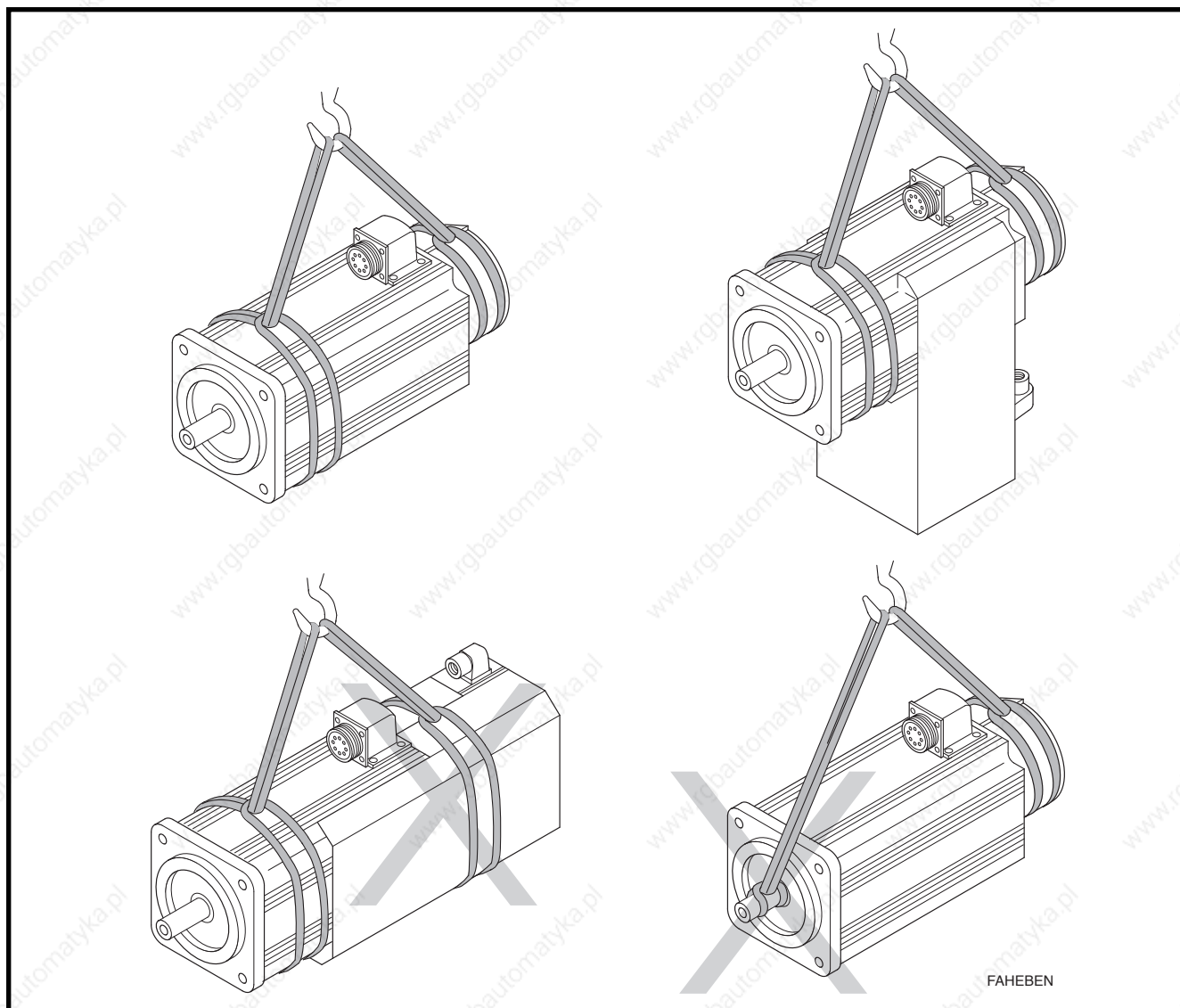

Fig 16.2: Picking up and transporting the motors with the help of the crane belts

There are two M8 tapped holes in the housing of the MAC 112 and MAC 115 line of motors. Lifting screws, per DIN 580, can be screwed into place here. These can then be used for holding the motor in place by a suitable lifting device. The hooks of a chain tackle can, for example, be hooked into place here. See Figure 16.3 for illustration.

INDRAMAT does not automatically deliver these lifting hooks with the motor. The user must, therefore, supply them.



If an axial surface cooling blower is mounted to MAC 112 or 115 motors, then these may only be picked up by the lifting hooks.

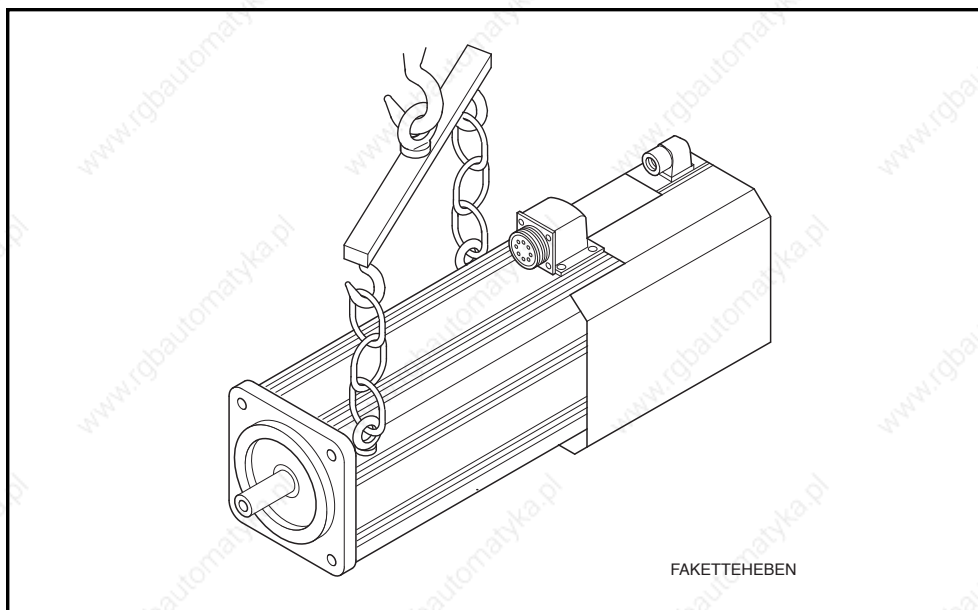

Fig 16.3: Picking up and transporting the MAC 112 and 115 series with chain tackle

17. Mounting and Installation Guidelines

The following guidelines must be followed to avoid damaging the machine when mounting or commissioning:

- The bigger and thus heavier motors may only be transported with the use of suitable lifting devices as described in the guidelines of section 16.
- Avoid impacts to the output shaft and heavy loads at the shaft as otherwise the bearings within the motor could be damaged.
- The motors should only be mounted to the machine by fully trained personnel.
- The spigot nuts on the connectors, e.g., motor power and feedback connectors, must be tightly screwed into place when connecting.
- The motor must be grounded to the drive amplifier.
- The terminal diagrams of the machine manufacturer should be followed when wiring the motor!
- Check the reference point settings when replacing motors (see section 2.4, "Motor feedback").
- The guidelines on cable routing are outlined in section 1.3.
- The guidelines on connecting the motor blower are outlined in section 2.3.

18. Service Notes

18.1. Contacting Customer Service

INDRAMAT customer service can be contacted at the following Service Hotline numbers during the times listed:

Service Hotline Phone number: 0172-6600406 or 0171-3338826

Monday - Friday 7.00 a.m. to 11.00 p.m. MET

Saturday 8.00 a.m. to 8.00 p.m. MET

Sundays and holidays 9.00 a.m. to 7.00 p.m. MET

We would appreciate your noting the following information prior to contacting Indramat customer service:

- type data of motor and drive
- the problem
- all fault and diagnostics displays

This will make it possible to quickly and definitively locate the problem.

When returning a motor, please include a copy of the repair card on the next page. Fill it out and send it in. This will enable us to locate the problem caused by their particular application.

18.2. Repair Card

| Repair Card for INDRAMAT equipment and components | | | |
|--|--|--|----------------------|
| Name: | | Company/Location: | |
| Date: | | | |
| Part number for exchange of single parts | | SN: | Consignment no.: |
| | | SN: | Delivery date: |
| Machine manufacturer/co.: | Type: | Machine no.: | Commissioning date: |
| Failure in axis: | <input type="checkbox"/> horizontal <input type="checkbox"/> vertical <input type="checkbox"/> | Operating time: | Date fault occurred: |
| Fault: Fault _____ _____ <input type="checkbox"/> constantly present <input type="checkbox"/> occurs sporadically <input type="checkbox"/> occurs after _____ hrs. <input type="checkbox"/> occurs with shocks <input type="checkbox"/> depends on temperature <input type="checkbox"/> other _____ _____ _____ | Additional data: (e.g., LED diagnosis, error in display) _____ _____ _____ _____ _____ _____ | Cause of fault: <input type="checkbox"/> unknown <input type="checkbox"/> connection fault <input type="checkbox"/> external short circuit <input type="checkbox"/> mechanical damage <input type="checkbox"/> loose cable(s) <input type="checkbox"/> other _____ _____ _____ | |
| Additional Data | | | |
| General data: <input type="checkbox"/> no function <input type="checkbox"/> drive not running smoothly <input type="checkbox"/> uncontrolled drive motions <input type="checkbox"/> error in one direction only <input type="checkbox"/> supply unit short-circuit fault <input type="checkbox"/> other | Concomitant phenomena: <input type="checkbox"/> Problems in mechanical sys. <input type="checkbox"/> Mains failure <input type="checkbox"/> Control failure <input type="checkbox"/> Motor failure <input type="checkbox"/> Break in cable <input type="checkbox"/> other | Drive, supply unit, amplifier, power section <input type="checkbox"/> control voltage faulty <input type="checkbox"/> power sect. circuit breaker F ____ <input type="checkbox"/> blower defective <input type="checkbox"/> bleeder resistor defective <input type="checkbox"/> power voltage faulty <input type="checkbox"/> connecting bolt broke <input type="checkbox"/> other | |
| Control: <input type="checkbox"/> no function <input type="checkbox"/> display failed <input type="checkbox"/> no command value output <input type="checkbox"/> diagnosis <input type="checkbox"/> dim. offset in _____ direction <input type="checkbox"/> E-stop loop interrupted <input type="checkbox"/> position control loop won't close <input type="checkbox"/> program sequence fault <input type="checkbox"/> interior auxiliary function faulty (outputs) <input type="checkbox"/> acknowledgements not accepted (inputs) <input type="checkbox"/> other _____ _____ | Motor: <input type="checkbox"/> thermo switch defective <input type="checkbox"/> brake defective <input type="checkbox"/> blower defective <input type="checkbox"/> feedback defective <input type="checkbox"/> tachometer signal faulty <input type="checkbox"/> BLC-signal faulty <input type="checkbox"/> short-circuit to ground <input type="checkbox"/> thermal overload <input type="checkbox"/> other _____ _____ _____ | Comments: _____ _____ _____ _____ _____ _____ | |

PIRepBegI

Fig 18.1: Repair card

19. Index

A

Absolute Encoder 34
Absolute Encoder Cable 177
Absolute Encoder Connector 176
Ambient mechanical conditions 14
Ambient temperatures 12
Angle connector 21
Applications 7
Axial surface cooling 17

B

Barcodesticker 181

C

Centering / pilot diameter 16
Condition at Delivery 180
Connection Incremental Encoder 173
Connection Tachofeedback 170
Connector-Cable Allocations 156
Construction 15
Cooling 10, 17

E

Electrical Connection Absolute Encoder 176
Electrical connections 11
Electrical Power Connection 155

F

Feedback 21
Feedback connection 23

G

Guidelines on Cable Routing 179

H

Holding brake 11, 19
Housing coat 15
How to order 169

I

Identifying the Merchandise 181
Incremental Encoder Cable 174
Incremental Encoder Connector 174
Incremental Encoders 28
Installation 10
Installation elevation 12

L

Limiting value for speed 39
Limiting value for torque 39

M

MAC 063 42
MAC 071 59

MAC 090 80
MAC 093 97
MAC 112 118
MAC 115 137
Motor 25
Motor blower connection 23
Motor feedback 9
Motor Power Cable 163
Motor Power Connector 162
Motor power connectors 23
Mounted Encoder 27
Mounted encoder 9
Mounting and Installation Guidelines 186
Mounting orientation 15
Mounting the absolute encoder 37

O

Operating reliability 10
Output shaft 11, 16
Output shaft with keyway 16

P

Performance data 10
Permissible shaft load 17
Plain output shaft 16
Power connection 20, 23
Power levels 8
Protection category 12

R

Radial surface cooling 18
Rating Plate 182
Ready-Made Absolute Encoder Cables 178
Ready-Made Incremental Encoder Cable for Encoders with Square-Wave
Pulses 175
Ready-Made Motor Power Cables 164
Ready-Made Tachofeedback Cable 172
Repair Report Card 188
Replacing the encoder 36

S

Second Shaft End 26
Service Notes 187
Service-Hotline 187
Setting the reference point 32
Setting the reference point of the absolute encoder 38
Shaft sealing 17
Smooth run qualities 11
Storage, Transport and Handling 183
Straight connector 21
Structure 9

T

Tachofeedback 9, 25, 26
Tachofeedback Cable 171
Tachofeedback Connector 170

| | |
|------------------------------|-----|
| Terminal Diagram | 155 |
| Terminal diagram | 22 |
| Thermal deformations | 17 |
| Torque-Speed Characteristics | 39 |

