

# Thermal Overload Relays



Data according to IEC 947-4-1, IEC 947-5-1, VDE 0660, EN 60947-4-1, EN 60947-5-1

Type		MCOR-1	U12/16 <sup>6)</sup>	MCOR-2	MCOR-3	MCOR-4	MCOR-5	MCOR-6	MCOR-7	MCOR-8	
Rated insulation voltage $U_i$ <sup>1)</sup>	V~	690	690	690	690	750	690	1000	1000	690	
Permissible ambient temperature operation	open °C								-25 to +55		
storage	°C								-40 to +70		
Trip class according to IEC 947-4-1	A	10	10	10	10	10	20	10	10	10	
<b>Cable cross-section</b>											
main connector	solid or stranded	mm <sup>2</sup>	0,75-6	0,75-6+0,75-2,5 <sup>2)</sup>	0,75-10	4-35 <sup>2)</sup>	3)	7)	-	7)	
	flexible	mm <sup>2</sup>	1-4	0,75-4+0,5-2,5 <sup>2)</sup>	0,75-6	6-25 <sup>2)</sup>					
	flexible with multicore cable end	mm <sup>2</sup>	0,75-4	0,5-2,5+0,5-1,5	0,75-6	4-25					
Cables per clamp	number	2	1+1	2	1						
auxiliary connector	solid	mm <sup>2</sup>								1-2,5 <sup>2)</sup>	
	flexible	mm <sup>2</sup>								1-2,5 <sup>2)</sup>	
	flexible with multicore cable end	mm <sup>2</sup>								1-2,5 <sup>2)</sup>	
Cables per clamp	number								2		
<b>Type</b>		<b>MCOR-1</b>	<b>U12/16</b>	<b>MCOR-2</b>	<b>MCOR-3</b>	<b>MCOR-4</b>	<b>MCOR-5</b>	<b>MCOR-6</b>	<b>MCOR-7</b>	<b>MCOR-8</b>	
Auxiliary contacts											
Rated insulation voltage $U_i$ <sup>1)</sup>											
same potential	V~	690	690	690	690	690	690	690	500	690	
different potential	V~	440	-	440	440	250	440	440	500	440	
Utilization category AC15											
Rated operational current $I_e$	24V A	3	4	5	5	4	5	3	4 <sup>5)</sup>	5	
	230V A	2	2,5	3	3	2,5	3	2	2,5	3	
	400V A	1	1,5	2	2	1,5	2	1	1,5	2	
	690V A	0,5	0,6	0,6	0,6	0,6	0,6	0,5	0,6	0,6	
Utilization category DC13											
Rated operational current $I_e$	24V A	1	1,2	1,2	1,2	1,2	1,2	1,2	1,2	1,2	
	110V A	0,15	0,15	0,15	0,15	0,15	0,15	0,15	0,15	0,15	
	220V A	0,1	0,1	0,1	0,1	0,1	0,1	0,1	0,1	0,1	
Short circuit prot. (without welding 1kA) highest fuse rating	gL (gG) A	4	4	6	6	6	6	4	6	6	
<b>Type</b>		<b>MCOR-1</b>	<b>U12/16</b>	<b>U12/16E</b>	<b>MCOR-2</b>	<b>MCOR-2</b>	<b>MCOR-3</b>	<b>MCOR-3</b>	<b>MCOR-3</b>	<b>MCOR-4</b>	
Setting range		all	to 23A	22 - 30A	to 28A	28 - 42A	to 52A	52 - 65A		all	
Power loss per current path (max.)											
minimum setting value	W	1,1	1,1	1,7	1,3	1,3	2,0	2,9		1,1	
maximum setting value	W	2,3	2,3	3,7	2,6	3,3	3,7	4,5		2,5	

## Data according to cULus

Type		MCOR-1	MCOR-2	U12/16E	MCOR-3	MCOR-4
Rated insulation voltage	V~	600	600	600	600	600
Rated current	A	32	23	42	74	85
Auxiliary contacts						
Rated voltage						
same potential	V AC	600	600	600	600	600
different potential	V~	150	150	150	150	150
Switching capacity of aux. contacts	VA	500	500	600	600	600
	A	2	4	4	4	4

## Temperature Compensation

In case of higher ambient temperature use the following formula:  
 (Ambient temperature - 20) x 0,125 = correction factor in % of the full load motor current

Example: Ambient temperature 70°C, full load motor current 7A  
 (70 - 20) x 0,125 = 6,25%  
 Setting value: 7A + 6,25% = 7,44A

- 1) Suitable for: earthed-neutral systems, overvoltage category I to III, pollution degree 3 (standard-industry):  $U_{imp} = 4kV$  (at 440V), 6kV (at 690V). Data for other conditions on request.
- 2) Maximum cable cross-section with prepared conductor
- 3) Without terminals, suitable for bushing one connector 70mm<sup>2</sup> (stranded) per phase
- 4) Switching capacity of the start contact: AC15 300VA, max. 1,5A, DC13 (max. 220V) 30W, max. 1,5A
- 5) Switching capacity of the make contact: AC15 400VA, max. 1,7A, DC13 (max. 220V) 10W, max. 1A
- 6) U12/16E 30: Cable cross-section for main connector like type MCOR-2, one connector only

# Thermal Overload Relays



## Dimensions

MC-10+ MCOR-1  
MC-14  
MC-18  
MC-22

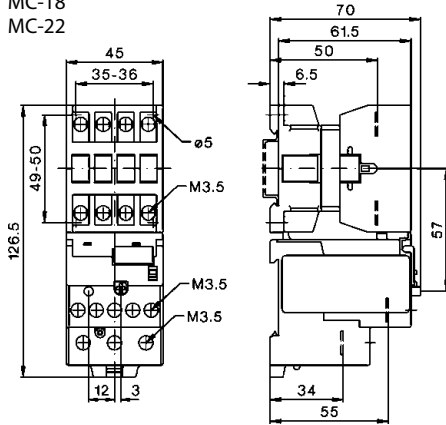

MCD-10 + MCOR-1  
MCD-14  
MCD-18  
MCD-22

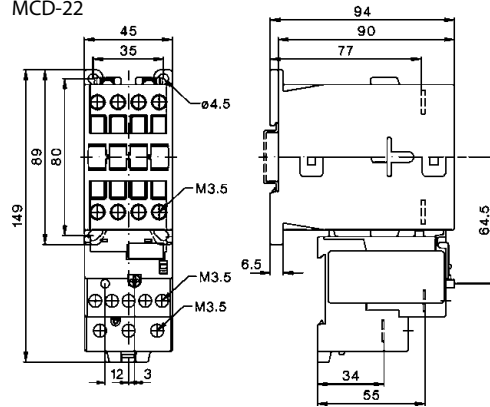

MC-24+ MCOR-1  
MC-32  
MC-40

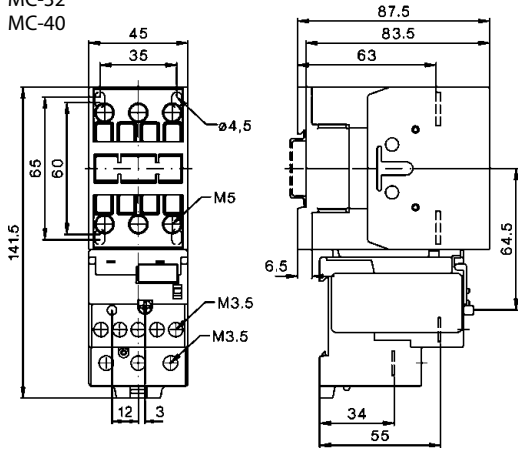

MCD-24 + MCOR-1  
MCD-32  
MCD-40

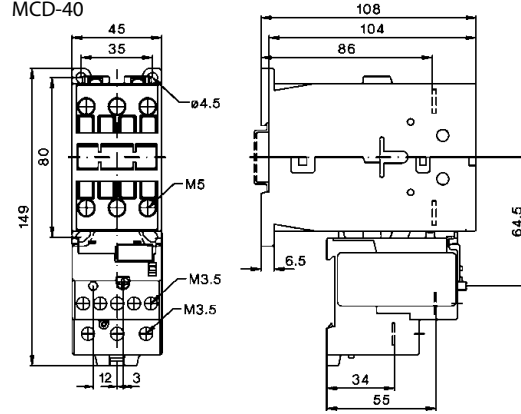

MC-24+ MCOR-2  
MC-32  
MC-40

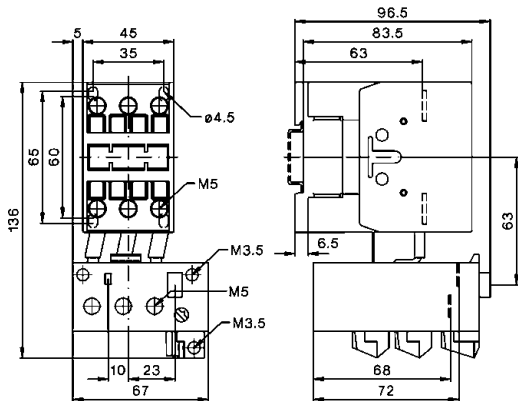

MCD-24 + MCOR-2  
MCD-32  
MCD-40

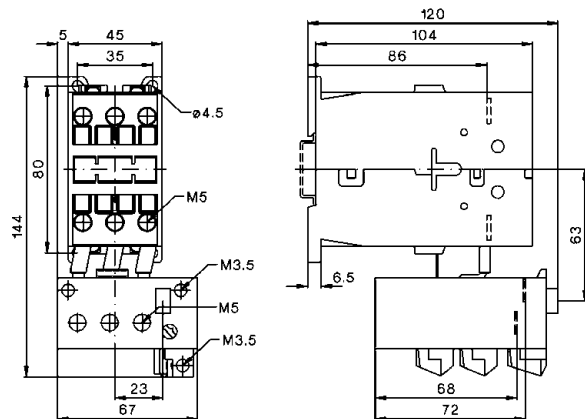

U3/32SM

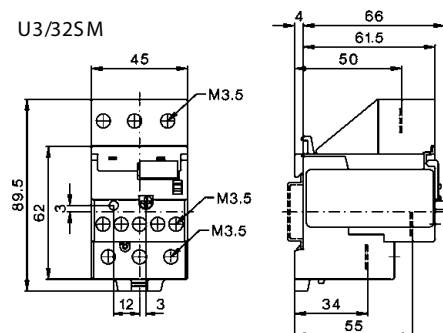

U3/42G +LG5830-4.

