

Technical Information

PrimeSTACK™

6PS18012E4FG35689



Preliminary data

General information

IGBT Stack for typical voltages of up to 400 V_{RMS}
 Rated output current 729 A_{RMS}

- High power converter
- Solar power
- Motor drives
- 62mm power module
- Trenchstop™ IGBT4

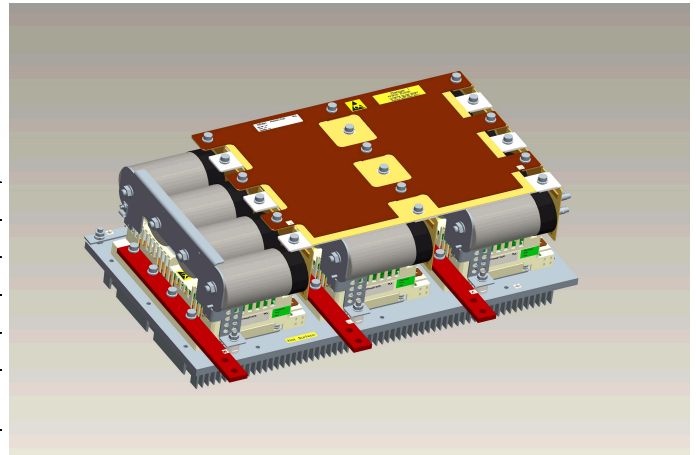

Topology	B6I
Application	Inverter
Load type	Resistive, inductive
Semiconductor (Inverter Section)	12x FF450R12KE4
DC Link	4.8 mF
Heatsink	Forced air cooled (fan not included)
Implemented sensors	Current, voltage, temperature
Design standards	UL 94, prepared for UL 508C
Sales - name	6PS18012E4FG35689
SP - No.	SP000885246

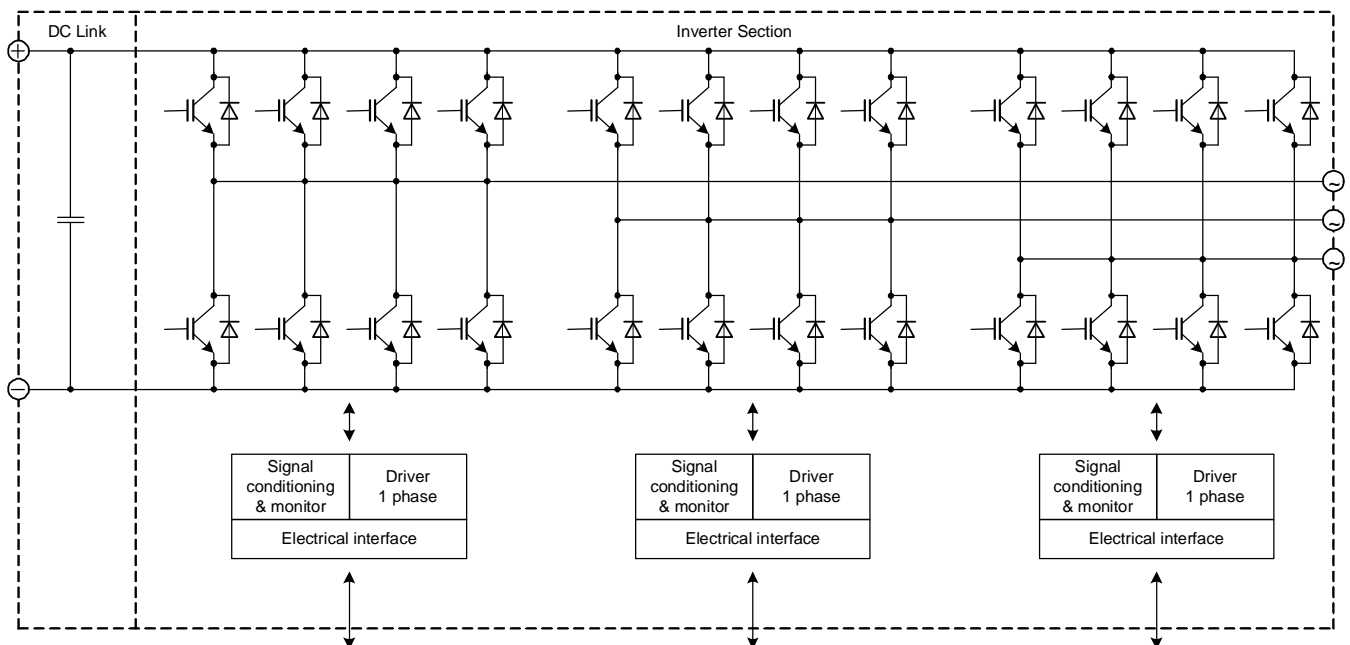

prepared by: OW	date of publication: 2012-07-11
approved by: SD	revision: 2.0

Technical Information

PrimeSTACK™

6PS18012E4FG35689



Preliminary data

Absolute maximum rated values

Collector-emitter voltage	IGBT; $T_{vj} = 25^{\circ}\text{C}$	V_{CES}	1200	V
Repetitive peak reverse voltage	Diode; $T_{vj} = 25^{\circ}\text{C}$	V_{RRM}	1200	V
DC link voltage		V_{DC}	850	V
Insulation management	according to installation height of 2000 m	V_{line}	500	V_{RMS}
Insulation test voltage	according to EN 50178, $f = 50\text{ Hz}$, $t = 1\text{ s}$	V_{ISOL}	2.5	kV_{RMS}
Repetitive peak collector current inverter section (IGBT)	$t_p = 1\text{ ms}$	I_{CRM2}	2500	A
Repetitive peak forward current inverter section (Diode)	$t_p = 1\text{ ms}$	I_{FRM2}	2440	A
I^2t -value inverter section (Diode)	$V_R = 0\text{ V}$, $t_p = 10\text{ ms}$, $T_{vj} = 125^{\circ}\text{C}$	I^2t	122	kA^2s
Continuous current inverter section		I_{AC2}	800	A_{RMS}
Junction temperature	under switching conditions	T_{vjop}	150	$^{\circ}\text{C}$

Notes

Further maximum ratings are specified in the following dedicated sections

Characteristic values

DC Link

			min.	typ.	max.	
Rated voltage		V_{DC}		650	800	V
Over voltage shutdown	within 5000 μs			850		V
Capacitor	1 s, 12 p	C_{DC}		4.8		mF
		type	Foil			
Maximum ripple current	per device, $T_{amb} = 55^{\circ}\text{C}$	I_{ripple}			49	A_{RMS}
Balance or discharge resistor	per DC link unit	R_b		82		k Ω

Inverter Section

			min.	typ.	max.	
Rated continuous current	$V_{DC} = 650\text{ V}$, $V_{AC} = 400\text{ V}_{RMS}$, $\cos(\varphi) = 0.85$, $f_{AC\ sine} = 50\text{ Hz}$, $f_{sw} = 5000\text{ Hz}$, $T_{inlet} = 40^{\circ}\text{C}$, $T_j \leq 125^{\circ}\text{C}$	I_{AC}		729		A_{RMS}
Continuous current at low frequency	$V_{DC} = 650\text{ V}$, $V_{AC} = 400\text{ V}_{RMS}$, $\cos(\varphi) = 0.85$, $f_{AC\ sine} = 0\text{ Hz}$, $f_{sw} = 5000\text{ Hz}$, $T_{inlet} = 40^{\circ}\text{C}$, $T_j \leq 125^{\circ}\text{C}$	$I_{AC\ low}$		360		A_{RMS}
Rated continuous current for 150% overload capability	$I_{AC\ 150\%} = 925\text{ A}_{RMS}$, $t_{on\ over} = 3\text{ s}$, $T_j \leq 125^{\circ}\text{C}$	$I_{AC\ over1}$		617		A_{RMS}
Rated continuous current for 150% overload capability	$I_{AC\ 150\%} = 803\text{ A}_{RMS}$, $t_{on\ over} = 60\text{ s}$, $T_j \leq 125^{\circ}\text{C}$	$I_{AC\ over2}$		535		A_{RMS}
Over current shutdown	within 15 μs	$I_{AC\ OC}$		2500		A_{peak}
Power losses	$I_{AC} = 729\text{ A}$, $V_{DC} = 650\text{ V}$, $V_{AC} = 400\text{ V}_{RMS}$, $\cos(\varphi) = 0.85$, $f_{AC\ sine} = 50\text{ Hz}$, $f_{sw} = 5000\text{ Hz}$, $T_{inlet} = 40^{\circ}\text{C}$, $T_j \leq 125^{\circ}\text{C}$	P_{loss}		6790		W

Notes

Maximum junction temperature limited to 125 $^{\circ}\text{C}$ under all operating conditions

prepared by: OW	date of publication: 2012-07-11
approved by: SD	revision: 2.0