

Model Number

50FR2-3-1

Features

- Magnetically actuated reed switch
- Hermetically sealed contacts
- AC/DC compatibility
- Matching permanent magnet

Connection

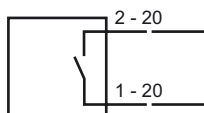

Accessories

52FR1

Dimensions

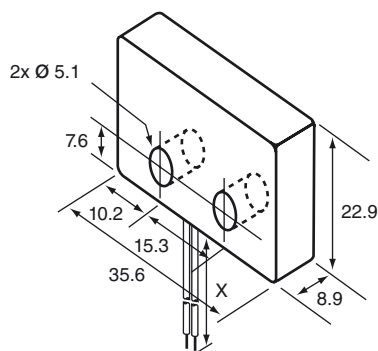

Technical Data

General specifications

Switching element function	Reed Contact Normally Open
Rated operating distance	s_n 11.4 mm
Installation	not embeddable
Output polarity	AC/DC
Mechanical life	3×10^7 operations

Nominal ratings

Operating voltage	U_B	100 V DC, 250 mA 115 V AC, 250 mA
Hysteresis	H	≥ 2.54 mm
Contact resistance		0.2Ω
Insulation resistance		$\geq 100 \text{ M}\Omega$ at 200 V DC
Dielectric strength		200 V AC, 60 Hz
Release point		≤ 17.8 mm

Electrical specifications

Electrical rating	AC supply: 10 VA, 132 V AC, 750 mA DC supply: 10 W, 100 V DC, 300 mA
-------------------	---

Ambient conditions

Ambient temperature	-40 ... 125 °C (-40 ... 257 °F)
---------------------	---------------------------------

Mechanical specifications

Connection type	cable PVDF, 914 mm
Core cross-section	0.5 mm^2
Housing material	Phenolic
Sensing face	Phenolic
Protection degree	IP68