

ISL29125

Digital Red, Green and Blue Color Light Sensor with IR Blocking Filter

FN8424
Rev.3.00
Jan 13, 2017

The [ISL29125](#) is a low power, high sensitivity, RED, GREEN and BLUE color light sensor (RGB) with an I²C (SMBus compatible) interface. Its state-of-the-art photodiode array provides an accurate RGB spectral response and excellent light source to light source variation (LS2LS). The ISL29125 is designed to reject IR in light sources allowing the device to operate in environments from sunlight to dark rooms. The integrating ADC rejects 50Hz and 60Hz flicker caused by artificial light sources. A selectable range allows the user to optimize sensitivity suitable for the specific application. In normal operation mode the device consumes 56µA, which reduces to 0.5µA in power-down mode. The ISL29125 supports hardware and software user programmable interrupt thresholds. The Interrupt persistency feature reduces false trigger notification. The device operates on supplies (VDD) from 2.25V to 3.63V, I²C supply from 1.7V to 3.63V, and operating temperature across the -40°C to +85°C range.

Related Literature

[AN1914](#), "Evaluation Hardware/Software User Manual for RGB Sensor"

AN1910, "Enhancing RGB Sensitivity and Conversion Time"

Features

- 56µA operating current, 0.5µA shutdown current
- Selectable range (Via I²C)
- I²C (SMBus compatible) output
- ADC resolution 16 bits
- Programmable interrupt windows
- Two optical sensitivity ranges
 - Range 0 = 5.7m lux to 375 lux
 - Range 1 = 0.152 lux to 10,000 lux
- Operating power supply 2.25 to 3.63V
- I²C power supply 1.7V to 3.63V
- 6 Ld ODFN (1.65x1.65x0.7mm) package

Applications

- Smart phone, PDA, GPS, tablet PCs, LCD-TVs, digital picture frames, digital cameras
- Dynamic display color balancing
- Printer color enhancement
- Industrial/commercial LED lighting color management
- Ambient light color detection/correction
- OLED display aging compensation

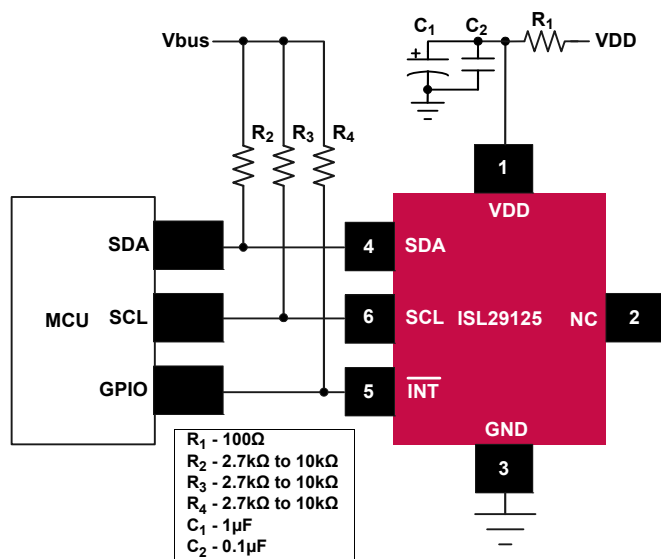

FIGURE 1. TYPICAL APPLICATION DIAGRAM

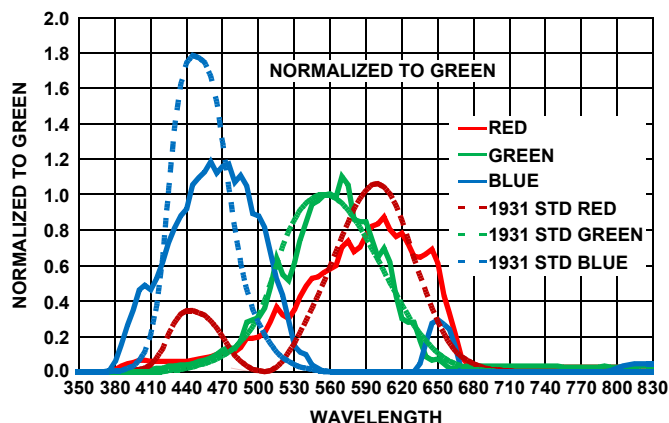
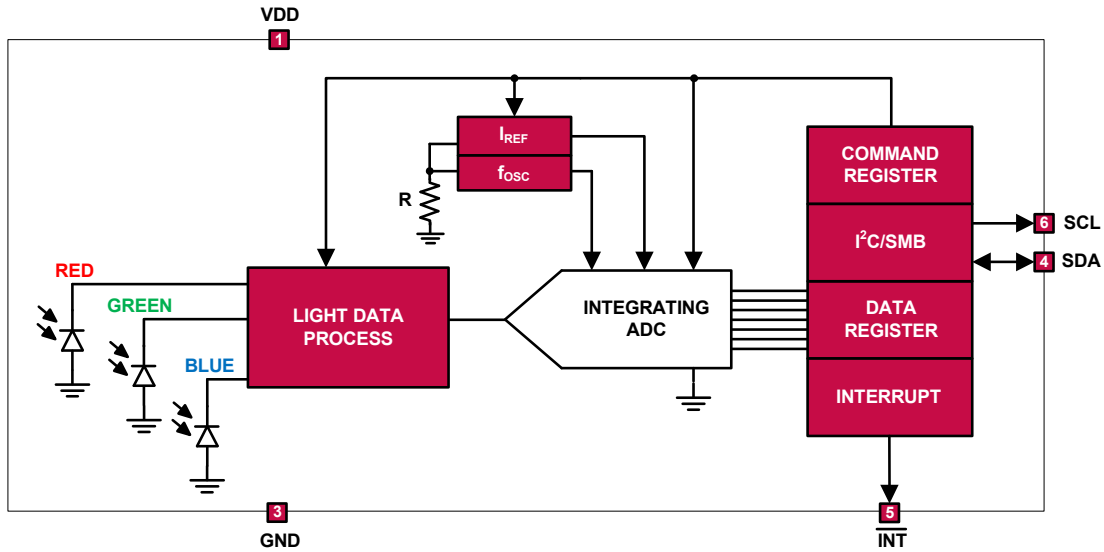
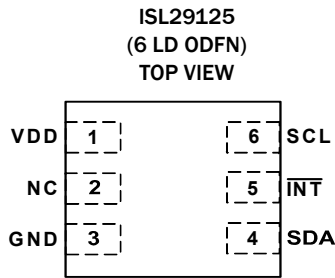

FIGURE 2. NORMALIZED SPECTRAL RESPONSE FOR RED, GREEN AND BLUE SENSING

Block Diagram



Pin Configuration



Pin Descriptions

PIN NUMBER	PIN NAME	DESCRIPTION
1	VDD	Positive supply
2	NC	No Connect
3	GND	Ground
4	SDA	I ² C serial data
5	INT	Interrupt; LOW for interrupt alarming. $\overline{\text{INT}}$ pin is an open drain. $\overline{\text{INT}}$ remains asserted until the interrupt status bit is reset. $\overline{\text{INT}}$ also becomes an input when it is set in SYNC mode.
6	SCL	I ² C serial clock

Ordering Information

PART NUMBER (Notes 1, 2, 3)	TEMP RANGE (°C)	TAPE AND REEL QUANTITY	PACKAGE (RoHS Compliant)	PKG. DWG. #
ISL29125IROZ-T7	-40 to +85	3,000	6 Ld ODFN	L6.1.65x1.65
ISL29125IROZ-T7A	-40 to +85	250	6 Ld ODFN	L6.1.65x1.65
ISL29125EVAL1Z	Evaluation Board			

NOTES:

1. Please refer to [TB347](#) for details on reel specifications.
2. These Intersil Pb-free plastic packaged products employ special Pb-free material sets; molding compounds/die attach materials and NiPdAu plate - e4 termination finish, which is RoHS compliant and compatible with both SnPb and Pb-free soldering operations. Intersil Pb-free products are MSL classified at Pb-free peak reflow temperatures that meet or exceed the Pb-free requirements of IPC/JEDEC J STD-020.
3. For Moisture Sensitivity Level (MSL), please see product information page for [ISL29125](#). For more information on MSL please see tech brief [TB477](#).