



HEAD OFFICE

INMOTION TECHNOLOGIES AB

Solkraftsvägen 13
SE-135 70 Stockholm
SWEDEN
Telephone: +46 (0)8 682 64 00
Telefax: +46 (0)8 682 65 80

Info@inmotech.com

<http://www.inmotech.com>

APPLICATIONS CENTERS

GREAT BRITAIN

Inmotion Technologies
/Danaher Motion
Bridge Mills
Holmfirth
Huddersfield
HD9 3TW
Telephone: +44 (0)1484 68 83 25
Telefax: +44 (0)1484 68 83 26

GERMANY

ACC Motion GmbH
Zähringerstrasse 23
DE-77654 Offenburg
Telephone: +49 (0)781 919 08-0
Telefax: +49 (0)781 919 08-29

ITALY

Danaher Motion Srl
Via Brughetti Z.I.
IT-20030 Bovisio Masciago (MI)
Telephone: +39 0362 594 260
Telefax: +39 0362 594 263

SWEDEN

Inmotion Technologies AB
Solkraftsvägen 13
SE-135 70 Stockholm
Telephone: +46 (0)8 682 64 00
Telefax: +46 (0)8 682 65 80

Inmotion Technologies AB
Box 195
SE-234 23 Lomma
Telephone: +46 (0)40 41 48 50
Telefax: +46 (0)40 41 48 55

SWITZERLAND

ACC Motion SA
Wehntalerstrasse 6
CH-8154 Oberglatt
Telephone: +41 (0)1 851 5010
Telefax: +41 (0)1 851 5020

ACC Motion SA
La Pierreire
CH-1029 Villars-Ste-Croix
Telephone: +41 (0)21 863 6464
Telefax: +41 (0)21 863 6479

U.S.A.

Inmotion Technologies
211 Overlock Drive
Sewickley, PA 15143-2305
Telephone: +1 (412) 749 0710
Telefax: +1 (412) 749 0705

DMC²

Digital Motion Control System
Part A

User's Manual 5.1

Art.No. 9032 0027 01 (A)

12.07.2001

Inmotion Technologies AB
Stockholm, Sweden

© Inmotion Technologies AB, 2001.
All rights reserved.

Table of Contents

Table of Contents.....	3
Introduction	7
About DMC ² Documentation	7
Copyright Notice	7
Scope of DMC ² User's Manual	7
Related Documentation	7
Warning, Caution and Information Notices	7
About the DMC ² Products	8
Personal Safety.....	8
Intended Use of the DMC ²	8
OEM'S Responsibility	8
Product Identification.....	9
Trademark Acknowledgements	10
Proprietary Statement.....	10
Warranty Statement.....	10
Regulations and Directives.....	11
Certification	11
Electrical Regulations	11
Mechanical Regulations.....	11
EMC	11
European Directives.....	12
DMC ² Maintenance Notice	12
Overview of Power Drive System.....	13
General.....	13
System Definitions based on IEC Standards	13
Power Drive System	13
Complete Drive Module	14
Basic Drive Module.....	14
Feeding Section and Auxiliaries	14
Motor and Sensors.....	15
System Controller	15
Internal Interfaces of the PDS.....	15
Configuring Power Drive Systems	17
Introduction.....	17
Power Drive System with the DMC ²	17
DMC ² unit	21
Control Section	21
Control Unit.....	21
Resolver Measuring.....	21
Inputs and Outputs.....	21
Enable Input.....	22
Ready Relay	22
Position and Speed Regulator	23
Positioning Unit (Controller).....	23
Communication Unit.....	23
Program Memory	23
Motor Temp Input.....	23
Brake Relay	23
Converter Faults	23
Commutating logic.....	23

LED Unit.....	23
DC/DC (converter)	24
Power Supply Section.....	24
Internal EMC Filter	25
Inrush Current Protection.....	25
Rectifier	25
Storage Capacitor	25
Dynamic brake (Regeneration, Bleeder or Shunt Circuit)	25
Converter section.....	26
Short circuit protection	26
Temperature (Drive over-temperature protection).....	26
Over Voltage Level	26
Logic Voltage Level.....	26
Step Down DC/DC Converter	26
Isolated DC/DC converter.....	27
Current Measuring	27
Dynamic Brake Control (Regeneration Bleeder or Shunt Control).....	27
Dynamic Brake Monitor	27
Selecting a DMC ² for the Application	27
Performance Summary AC supplied DMC ²	27
Performance Summary DC supplied DMC ²	27
Stand-alone Power Supplies, PS Units	27
Connector Kit for DMC ²	27
Cabling.....	28
Power Cable	28
Motor Cable	28
Resolver Cable	28
Communication Cable.....	29
Control Circuit Cable.....	29
Fuses.....	29
Requirements.....	29
EMC filters	30
Requirements.....	30
Contactors	30
Main Contactor Selection.....	30
Inrush Current Contactor Selection.	30
External Dynamic Brake Resistors.....	31
Example 1. Continuous power, 130W and peak power 8kW.	31
Example 2. for PS580160 minimum resistans 10Ω.....	31
Transformer Selection	32
Example of System Configurations	32
Drive Combination	32
Sizing Components of the DMC ² System.....	32
DMC² Tables.....	33
Performance Summary AC Supplied DMC ²	33
Performance Summary DC Supplied DMC ²	33
Performance Summary Stand-alone Power Supplies, PS units.	34
Connector Kit for DMC ²	35
Motor cable, COMBI CY.....	36
High flex motor cable, EUROFLEX S 801 C	36
Strain reliefs for motor cable	36
Resolver cables with connectors for EP motors.....	37
Resolver cables with connectors for SEM motors.....	37
Resolver cables, by the meter.....	37
High flex resolver cables	37

Strain reliefs for resolver cable.....	38
Communications cables DMC ² - PC.....	38
Communications cables DMC ² - DMC ²	38
Communications cables DMC ² – Terminal PC.....	38
Sync cable.....	39
DMC ² syncbox.....	39
Connector.....	39
Recommended EMC filters.....	40
Recommended main contactors.....	40
Recommended inrush current contactors.....	40
Recommended inrush resistors.....	41
System configuration DMC ²	41
System Configurations 400 VAC.....	41
Rating for System Configurations 400 VAC.....	41
DMC² Connections.....	45
General.....	45
X Connector's.....	46
DSUB Connector's.....	46
DMC ² Front.....	47
DMC ² I/O Connections.....	48
DMC ² 50412/P, DMC ² 50720/P.....	49
DMC ² 51540/P, DMC ² 53080.....	50
Power Supply 580160.....	51
X1.....	51
X2.....	52
X4 (host).....	52
X5 (next).....	53
X4 and X5 connection.....	53
RS 232 Interface.....	53
Communication between DMC ²	53
LAN 1 communication.....	54
X6A.....	54
Resolver and external resolver connection.....	55
Resolver Connection from motor.....	55
External resolver.....	55
Syncbox.....	55
X6B.....	56
X7A/B.....	57
Pinouts user I/O.....	57
I/O Connection Examples.....	58
NPN Transducer, Open Collector Type.....	58
PNP Transducer.....	58
High speed input (digital input1).....	59
Unipolar Analog Input.....	59
Bipolar Analog Input.....	60
Standard DMC ² Output.....	60
Analog Outputs.....	61
X8A.....	61
X9A.....	62
X10.....	62
X11.....	62
X13.....	63
X14.....	63
X20.....	64
X21.....	64

X22	65
X23	65
X31	66
X32 & X33	66
DMC ² 50412 or DMC ² 50720 DC Bus Connection	66
DMC ² 51540 or DMC ² 53080 DC Bus Connection	67
X34	67
X35	67
Input wiring diagram	68
Single Installation	68
DMC ² -P/DMC ² Installation	69
Power Supply/DMC ² 50412, 50720 Installation	70
Power Supply/DMC ² 51540, 53080 Installation	71
Installing the DMC ² in a cabinet	73
General	73
Separation of Control and Power Areas	73
Installation example	74
Cabinet Space Requirements	76
Mounting Dimensions and Clearances	76
Electromagnetic Compatibility Considerations	78
Screening	78
Strain Relief	79
Grounding for High Frequencies	79
Protective Earth Grounding	80
Thermal Considerations	80
Technical Specifications	81
570 V DC Bus model	81
400 V AC Bus models	82
Stand Alone Power Supply	83
I/O	83
External Logic Supply	84
Optional Position Sensors	85
Measure Connection	85
LAN2	85
Environmental Data	85
Environmental Tests	85
Resolver Specification	86
Start up and Commissioning	87
Checks Prior to Initial Power up	87
Before power up the firsts time	87
Before enable the power stage after power up	87
Load a new firmware release	87
Boot mode command	88
Startup message	88

Introduction

ABOUT DMC² DOCUMENTATION

This version replaces all previous versions of this document. Inmotion Technologies AB has made every effort to insure this document is complete and accurate at the time of printing. In accordance with our policy of continuing product improvement, all data in this document is subject to change or correction without prior notice.

COPYRIGHT NOTICE

This manual is copyrighted 2001 by Inmotion Technologies AB. All rights reserved. This manual may not be copied in whole or in part, nor transferred to any other media or language, without the express written permission of Inmotion Technologies AB.

SCOPE OF DMC² USER'S MANUAL

This manual is intended for users of the DMC² (Digital Motion Controller) who will be designing, integrating and installing motion control systems based on the DMC². The manual presents requirements, guidelines and examples for utilizing the DMC² along with other motion system components.

RELATED DOCUMENTATION

For comprehensive information on details on the DMC² programming language and programming tools and controller firmware refer to the User's Manual 5.x Part B.

WARNING, CAUTION AND INFORMATION NOTICES

Special attention must be paid to the information presented in Warning, Caution and information notices when they appear in this manual. Examples of Caution, Warning and information notices along with an explanation of their purposes follow.

	WARNING <ul style="list-style-type: none">◆ A Warning informs the user of a hazard or potential hazard that could result in serious or fatal injury if the precautions or instructions given in the warning notice are not observed.
---	---

	CAUTION <ul style="list-style-type: none">◆ A Caution informs the user of a hazard or potential hazard that could result in injury or damage to the equipment if the precautions or instructions given in the caution notice are not observed.
---	---

	An Information Box contains supplemental information or references to supplemental information on a topic.
---	---



Stop Box highlights important conceptual or procedural details that must be understood and applied in order to successfully use the product.

ABOUT THE DMC² PRODUCTS

PERSONAL SAFETY

- We provide this and other manuals to assist manufacturers in using the DMC² in a correct, efficient and safe manner. Manufacturers must insure that all persons responsible for the design and use of equipment employing the DMC² have the proper professional skill and apparatus knowledge and follow the instructions in this manual.



WARNING

- ◆ The DMC² contains voltages, which may be as high as 575 volts and rotating parts on motors and driven equipment. High voltage and moving parts can cause serious or fatal injury. Only qualified personnel familiar with this manual, software control of the DMC² and machinery driven by this equipment should attempt to start up or troubleshoot this equipment.
- ◆ DO NOT touch electrical components, power devices or connections without first insuring that high voltage is not present. Storage capacitors within the equipment require 20 seconds to discharge after AC power is removed.
- ◆ The unit must be properly grounded. DO NOT apply AC power until all earth grounds have been installed.
- ◆ Incorrect programs, faulty equipment or faulty or incorrect connections may cause sudden, violent motion of the motor shaft and driven equipment. Be certain that unexpected motor shaft movement will not cause injury to personnel or damage to equipment. Peak torque of several times rated motor torque can occur during a control failure.
- ◆ High voltages may be present at the motor whenever AC power is applied, even when the motor is not moving.

INTENDED USE OF THE DMC²

The Digital Motion Controller™ (DMC²) is intended for precise torque, speed and position control applications in different industrial equipment.

OEM'S RESPONSIBILITY

OEM's are responsible for ensuring that DMC² are used for their intended purpose only, safe function of the system and for compliance with all applicable regulations.

Responsibility for the safe functioning of the system reverts to the owner or user in all cases in which a non-professional has done installation, service or repair and when the system is used for other than its intended purpose.

PRODUCT IDENTIFICATION

A label (see [Figure 1](#) for location) and [Figure 2](#) for containing pertinent product identification information is affixed to the DMC2 unit. The product label fields relevant to product identification are described below [Table 1](#).



Figure 1. Product Label location.



Figure 2. DMC² Product Identification Label.

Product Identification

Field	Description
Part No	Unique part number assigned to DMC ² with a specific Supply Voltage.
Edition	Indicates the revision level of the article.
Cat. No. DMC ² model	<p>5 0 4 1 2 P - CAN</p> <p>Bus voltage 5 = 570 VDC</p> <p>Cont. current (pk) 04 = 4 A</p> <p>Max. current 12 = 12 A</p> <p>Power supply P = Integral Omit = No integral power supply</p> <p>Options CAN = Extended CAN</p> <p style="text-align: right;">A137</p>
Serial No.	Production lot number (assigned by the factory). The production lot numbers together with the sequence number yield a unique serial number for each DMC ² .
Sequence number	Serial number within a production lot.
Manufacture date	Year, month and day of manufacture.

Table 1. DMC² Product expressions.

TRADEMARK ACKNOWLEDGEMENTS

IBM, IBM PC, AT and PC/XT are registered trademarks of International Business Machines Corporation.

Intel is a registered trademark of Intel Corporation, registered in the United States Patent and Trademark Office.

Microsoft, MS-DOS, Excel and Windows are registered trademarks of Microsoft Corporation, registered in the United States and Trademark Office.

Novell and NetWare are registered trademarks of Novell Inc., registered in the United States Patent and Trademark Office.

PROPRIETARY STATEMENT

The digitally encoded software included in the DMC² is copyrighted 2001 by Inmotion Technologies AB. All rights reserved. This software may not be reproduced, modified, displayed, transferred or copied in any form or in any media, in whole or in part, without the express written from us.

WARRANTY STATEMENT

We make no warranty of any kind including, but not limited to, any implied warranties of merchantability and fitness for a particular purpose with regard to this manual. We assumes no responsibility or liability for errors contained in this manual or for incidental, special or consequential damages arising out of the furnishing of this manual, or the use of this manual in operating the equipment, or in connection with the performance of the equipment when operated.

REGULATIONS AND DIRECTIVES

CERTIFICATION

- The DMC² shall be put into operation and be used only by authorized personnel.
- Local or national safety regulations in the field of electrical installation shall be followed.

ELECTRICAL REGULATIONS

- The system is driven by high voltage level of 3-phase 400 VAC. Make sure that the system is not connected to mains when installation, service or repair is done.
- The system must be turned off before changing cables or accessories.
- Non-Compliance with the installation instructions in this manual can either damage the system or cause an electrical shock.
- The system can start automatically when mains are turned on depending on how the hardware and software configuration is defined.
- When a computer is connected to the DMC² unit, make sure that both the DMC² and the computer are connected to earth ground, for avoidance of unpredictable voltage swing.

MECHANICAL REGULATIONS

- The servo motor connected to the DMC² unit consists of moving parts and can perform high torque's and/or speed in short time (within a few ms).
- Some parts of the DMC² unit can be very warm, up to 90°C.
- The system shall be installed in a cabinet that gives Pollution Degree 2

EMC

- The DMC² unit is designed to fulfill European EMC directive 89/336/EEC referring to EN50081-2 Generic emission standard, Part 2, Industrial environment and EN50082-2 Generic immunity standard, Part 2, Industrial environment.
- The DMC² unit is designed to fulfill FCC (Federal Communications Commission) rules referring to Part 15.
- Proper installation and use according to this manual must be performed if the EMC requirements are to be fulfilled.
- The DMC² unit complies with the limits for a Class A digital device, pursuant to CISPR11 (International special committee on radio interference) This equipment generates, uses and radiate radio frequency energy and if not installed and used in accordance with this manual, may cause harmful interference to radio communications. Operation of the equipment in a residential area is likely to cause harmful interference in which case the user will be required to correct the interference using own expertise. A shielded cable is required to comply with the limits for a Class A digital device, pursuant to CISPR11.

DMC2 Maintenance Notice

EUROPEAN DIRECTIVES

The DMC² unit fulfills the EC requirements and carries the European CE sign. However, they will be declared as components for building-up machines. They will therefore not be powered as long as the machine itself does not comply with the European Directives.

DMC² MAINTENANCE NOTICE

The DMC² contains no internal adjustments, no fuses and no user-servable maintenance parts requiring removal of its protective covers. Software programs developed and maintained by DMC² users customize the unit for each application. Maintenance personnel must be aware that a DMC² swap may also require configuring the replacement unit to be configured with the correct software for the application.

Overview of Power Drive System

GENERAL

The DMC² is an intelligent motion controller, which together with motor and cables, is used for control of speed, position, acceleration and torque of a motor-driven axis in a machine or process. The DMC² is also able to process, control and coordinate a number of inputs and outputs (both digital and analog). The strength of its motion and I/O capabilities make the DMC² well suited for handling complex machine or process control applications.

The remainder of this chapter is devoted to defining a machine/process controller using standard terminology established by the IEC (International Electro-technical Commission).

SYSTEM DEFINITIONS BASED ON IEC STANDARDS

In this section the definitions of a Power Drive System as described by IEC will be stated. This is to clarify how the DMC² products are to be used in systems for a machine or process and which functional parts it is covering.

POWER DRIVE SYSTEM

A Power Drive System (PDS) is comprised of a Complete Drive Module, System Controller and motor with its included sensors. [Figure 3.](#) shows the boundary between the PDS and the process. If the PDS has its own dedicated transformer, this transformer is included as a part of the Complete Drive Module.

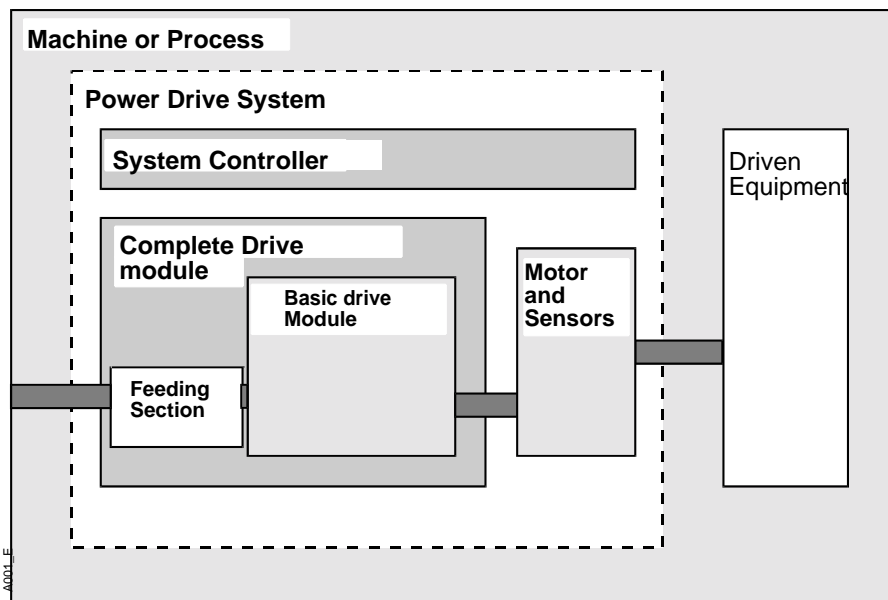

Figure 3. Power Drive System (PDS)

System Definitions based on IEC Standards

COMPLETE DRIVE MODULE

The Complete Drive Module (CDM) consists of a Basic Drive Module (BDM) and its possible extensions or auxiliaries such as the Feeding Section.

BASIC DRIVE MODULE

The BDM in [Figure 4](#). is comprised of a Converter Section, and Control Section. The Converter Section changes voltage, current and/or frequency of the power distribution network to voltage/current and/or frequency of the feeding network for the motor. The Converter Section can be divided into Input Converter and Output Converter. The Input Converter can be a rectifier. The Control Section monitors and controls the Converter Section. It also handles communication, I/O-signals and feedback devices.

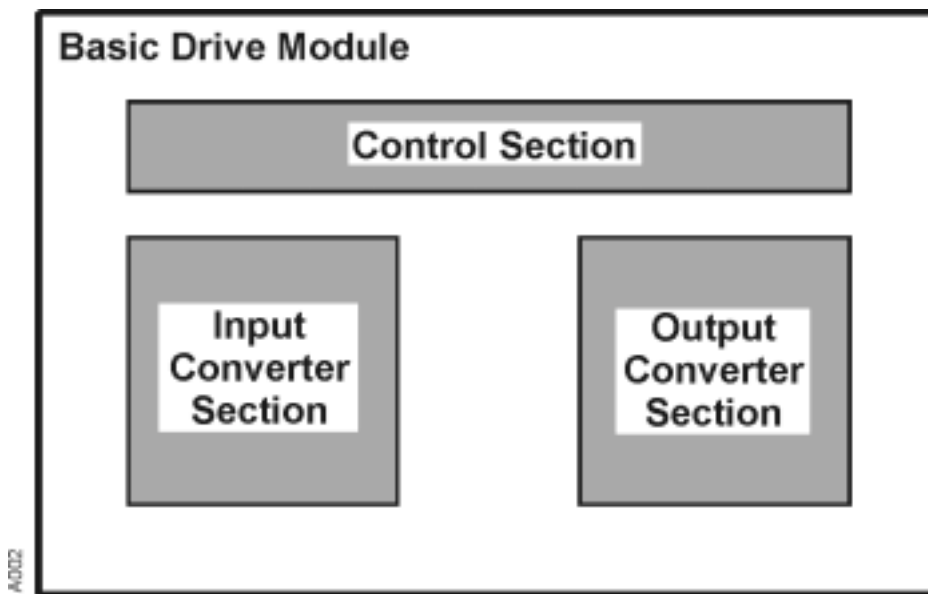

Figure 4. Basic Drive Module (BDM).

FEEDING SECTION AND AUXILIARIES

The Feeding Section consists of all parts between the mains and the input to the converter section including:

- Main switch.
- Input short circuit protective devices.
- Transformer.
- Filter.
- Inrush protection.
- Earth fault detection.
- Disconnecting means for auxiliary circuit.
- Drive overloads protection.
- Auxiliaries - start, stop and emergency stop circuits.

Parts of the feeding section may be physically located within the BDM.

MOTOR AND SENSORS

The motor (see [Figure 5.](#)) converts electrical energy to mechanical energy. By definition the motor includes those sensors, which are relevant to motor operation and interact with the CDM. The motor illustrated in [Figure 5.](#) includes the motor windings, temperature sensor, feedback device and brake include.

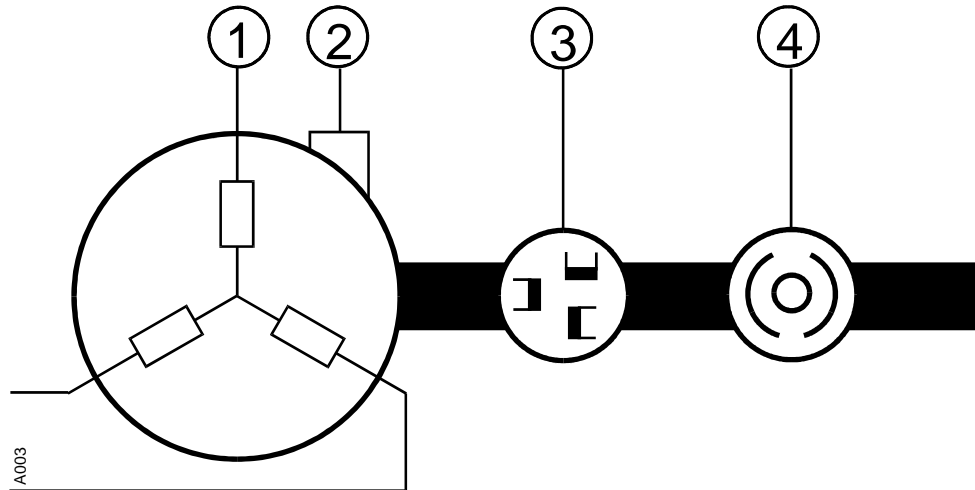

Figure 5. Motor with sensors.

1. Motor winding.
2. Temperature sensor.
3. Feedback device.
4. Brake.

SYSTEM CONTROLLER

The System Controller includes all the accessories needed for the PDS to perform its required functions. The system controller could include devices such as a:

- Man machine interface.
- Single or multi axis motion controller.
- PC.
- PLC.
- Terminal.
- Motion control unit.
- Multiaxis controller.

This function may be located external to the remainder of the PDS.

INTERNAL INTERFACES OF THE PDS

The PDS can have a signal interface for connection to a PC, terminal or PLC. It can also have a signal interface to other CDMs, or PDSes.

Configuring Power Drive Systems

INTRODUCTION

This chapter discusses configuring power drive systems and presents information on selection of system components including the DMC², cables, protective devices and others.

POWER DRIVE SYSTEM WITH THE DMC²

The DMC² is available in two configurations; AC Supply models, which contain an integral DC power, supply (input converter section) and DC Supply models, which have no integral DC power, supply. A stand-alone PS (power supply) unit is available for powering DC Supply models of the DMC².

A Power Drive System (PDS) utilizing DMC²s may be configured in several ways depending on the number of motion axes and the requirements for each axis:

- One or more AC supplied DMC² unit(s). See [Figure 6](#).
- One AC supplied DMC² unit supplying one or more DC supplied DMC² unit(s) with a DC bus interface. See [Figure 7](#).
- A stand-alone PS (power supply) unit supplying one or more DC supplied DMC² unit(s) with a DC bus interface. See [Figure 8](#).

Power Drive System with the DMC²

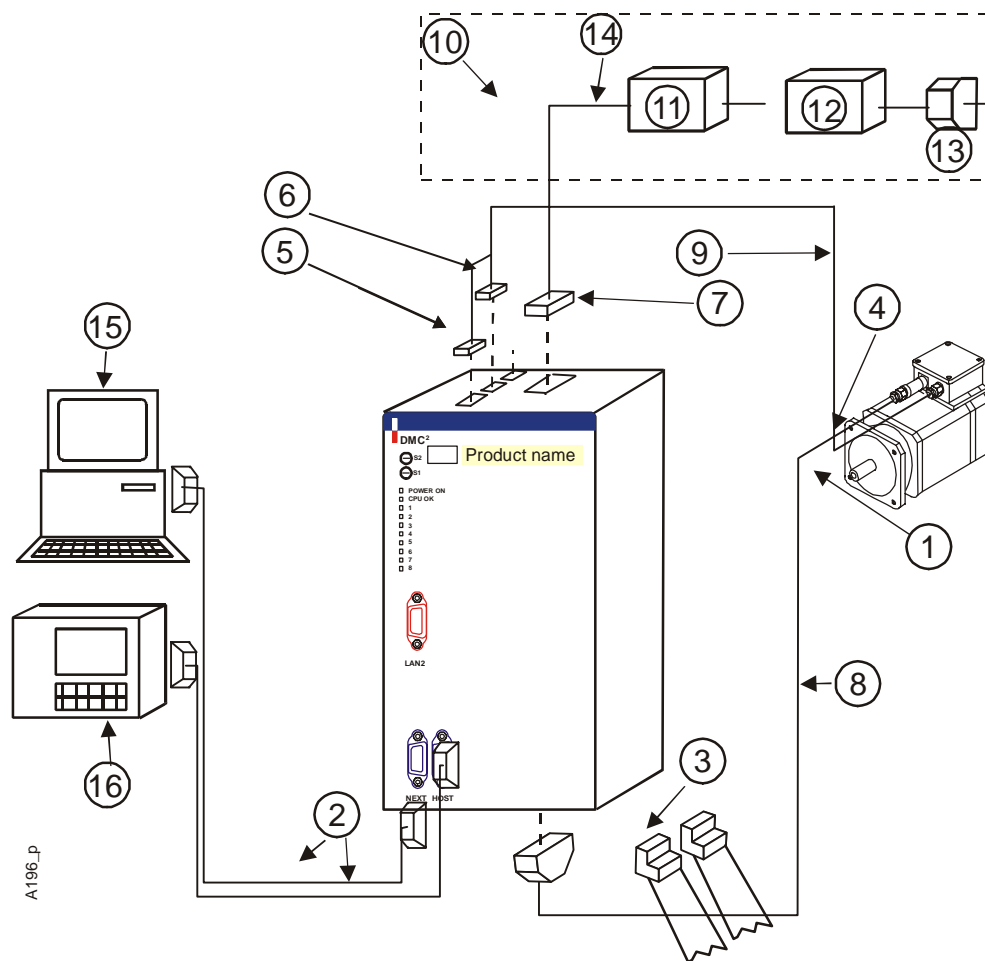

Figure 6. Example of PDS with an AC supplied DMC² unit.

1. Motor power connection.
2. Communication cable.
3. I/O connector.
4. Resolver connection.
5. Thermistor and brake relay connector.
6. Motor power connector.
7. Power connector.
8. Resolver cable.
9. Motor cable.
10. Feeding section.
11. Filter.
12. Contactor.
13. Fuse.
14. Power cable.
15. PC.
16. Terminal PC

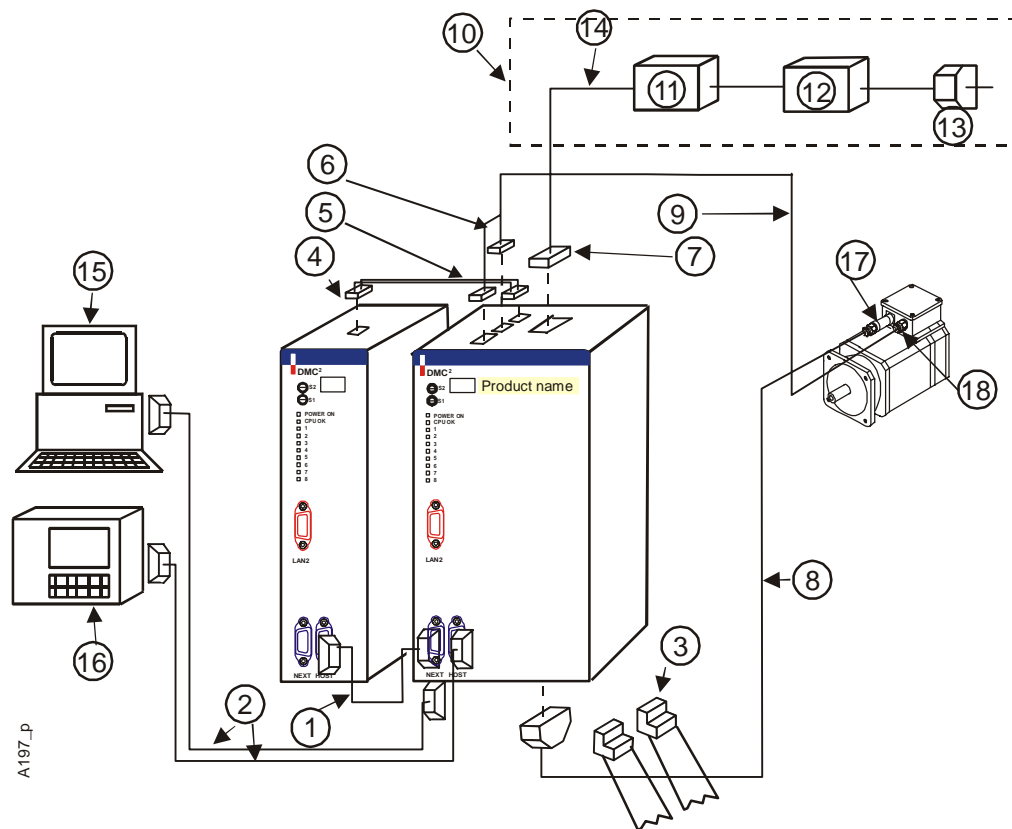

Figure 7. Example of PDS with an AC supplied DMC² unit and a DC supplied unit.

1. Daisy chain cable.
2. Communication cable.
3. I/O connector.
4. DC bus cable.
5. Thermistor and brake relay connector.
6. Motor power connector.
7. Power connector.
8. Resolver cable.
9. Motor cable.
10. Feeding section.
11. Filter.
12. Contactor.
13. Fuse.
14. Power cable.
15. PC.
16. Terminal PC.
17. Resolver connection.
18. Motor connection.

Power Drive System with the DMC2

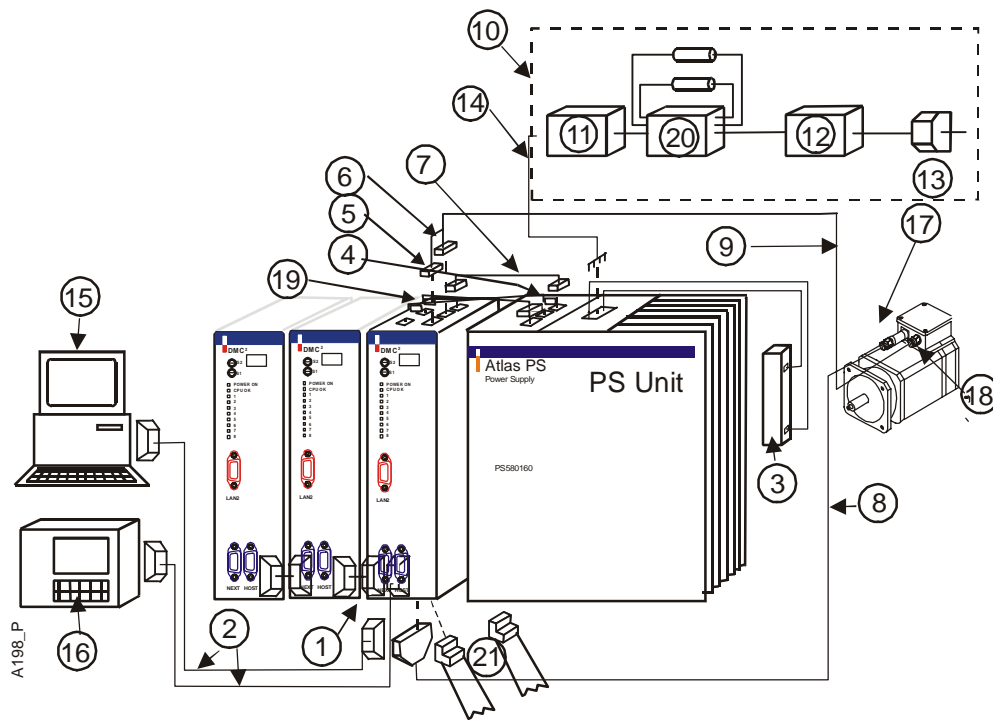

Figure 8. Example of PDS with DC supplied DMC² unit(s) driven by stand-alone PS (power supply) unit.

1. Daisy chain cabel.
2. Communication cable.
3. Dynamic brake resistance.
4. Temperature switch connector.
5. Thermistor and brake relay.
6. Motor power connector.
7. DC bus cable.
8. Resolver cable.
9. Motor cable.
10. Feeding section.
11. Filter.
12. Contactor.
13. Fuse.
14. Power cable.
15. PC.
16. Terminal PC.
17. Resolver connection.
18. Motor connection.
19. Dynamic brake control.
20. Contactor for inruch protection.
21. I/O connector.

DMC² UNIT

The DMC² is the Basic Drive Module in a Power Drive System illustrated in [Figure 9](#). It consists of a control section, converter section and, for AC-supplied models, part of the feeding section.

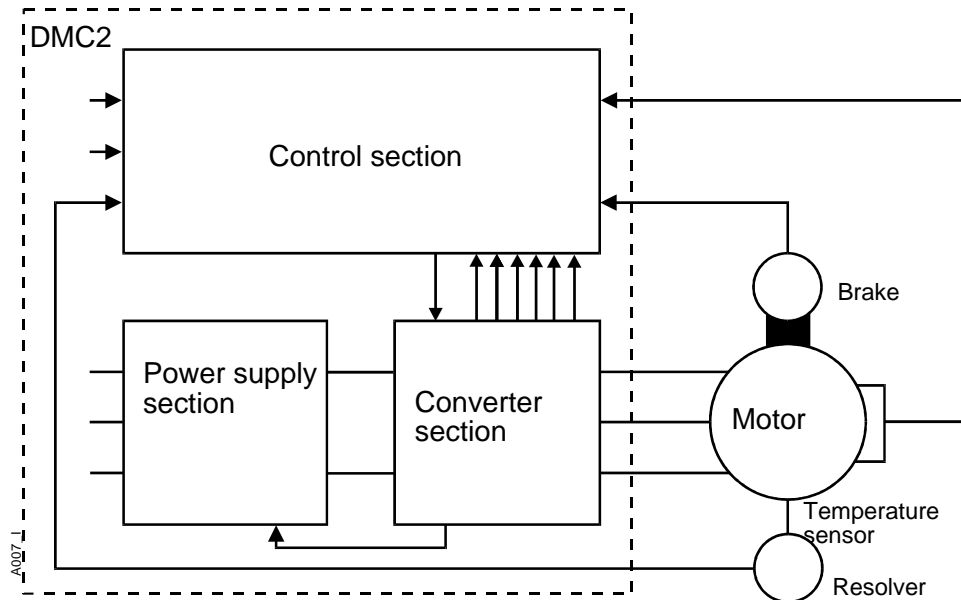

Figure 9. Block diagram of DMC².

CONTROL SECTION

[Figure 10](#). presents a block diagram of the Control Section of a DMC². Functions assigned to the blocks are described below

CONTROL UNIT

The control unit handles the firmware flow for each servo cycle, administrates the serial communication and executes the application code. The control unit apportions CPU time among the firmware, communications and the application.

RESOLVER MEASURING

Handles excitation and feedback signals from the resolver for control of rotor position, and axis speed and position. This function also supports a second resolver for master/slave tracking applications.

INPUTS AND OUTPUTS

Filters and processes analog and digital inputs and outputs such that external signals complying with international requirements and standards for programmable controllers are properly interpreted. There is also a High Speed Input (HSI) for fast indication.

DMC2 unit

ENABLE INPUT

Hardware input that must be high before the firmware can enable the power output stage of the Converter. When this input is low, the power output stage is disabled.

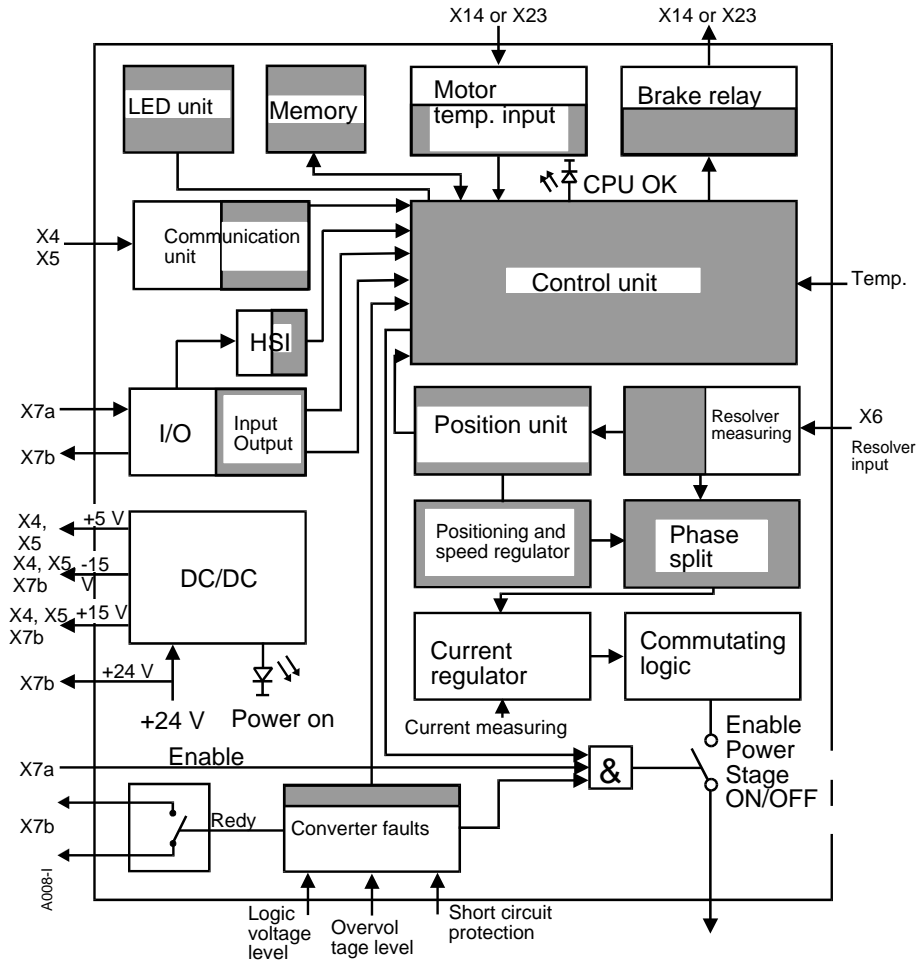

Figure 10. Control Section Block diagram. (Shaded blocks handled by software).

READY RELAY

A relay contact set that closes when no converter faults are indicated and the DMC² is ready for use. The ready relay will be open after power up until a reset pulse has been sent to the power stage in the converter section.

If one of these faults is indicated, the ready relay contact will open:

- Short circuit protection active in converter section.
- Over voltage level in converter section.
- Too low logic voltage level in converter section.
- Too low logic voltage level in control section
- **OUT.Fault** have been set from the software.

Any software fault can be programmed to set **OUT.Fault** and open the read relay contact.

POSITION AND SPEED REGULATOR

Combined position and speed PID regulator with different feed forward functions and programmable limit settings.

POSITIONING UNIT (CONTROLLER)

Includes Profile Generator, Electronic Gear Box, Pdata Array, Position Counter and Timers.

COMMUNICATION UNIT

Contains serial communication interface for RS-232, RS-422, Daisy chain, Sync signal (and CAN bus connection).

PROGRAM MEMORY

Contains memory for Firmware and application program and a non-volatile EEPROM memory for parameter storage.

MOTOR TEMP INPUT

For connection of the temperature sensor device in the motor. When the motor temperature input is active (open or high impedance), an internal variable (`Motor Temp.High`) is set. The variable `Motor Temp.High` can, in the application program, be used for shutting down the power output stage.

BRAKE RELAY

Software controlled relay that could be used for control of a brake in the motor.

CONVERTER FAULTS

Disables the power output stage and de-energizes the Ready relay upon recognition of a fault signal from the Converter section.

COMMUTATING LOGIC

Turns on and off the switches (IGBT's) in the output power stage depending on motor angle and magnitude of torque (current) command.

LED UNIT

A group of ten front panel LEDs. (Power On, CPU OK and LED 1 thru LED 8) and associated drive electronics.

LEDs controlled by hardware.

Power On	Green, lit when +5 V are available in controller section.
CPU OK	Green, lit when CPU has started up and runs.

LEDs controlled by software.

LD 1	Green, Software defined.
LD 2	Yellow, Software defined.
LD 3	Yellow, Software defined.
LD 4	Yellow, Software defined.
LD 5	Red, Software defined.
LD 6	Red, Software defined.

DMC2 unit

- LD 7 Red, Software defined.
- LD 8 Red, Software defined.

DC/DC (CONVERTER)

Reduces the +24VDC to +15VDC, -15VDC and +5VDC supply voltage for the logic in the controller section.

POWER SUPPLY SECTION

The power supply section converts three phase AC power to DC power which is used by the Converter section as a source of motor current. Figure 11. illustrates the power supply section of a AC supplied DMC² and Figure 12. illustrates the power supply section of a stand-alone power supply. The principal differences between the two configurations are:

- The stand-alone power supply does not include integral inrush current protection components.
- The regeneration resistor is integral to the AC supplied DMC². A separate external regeneration resistor must be provided for the stand-alone power supply.

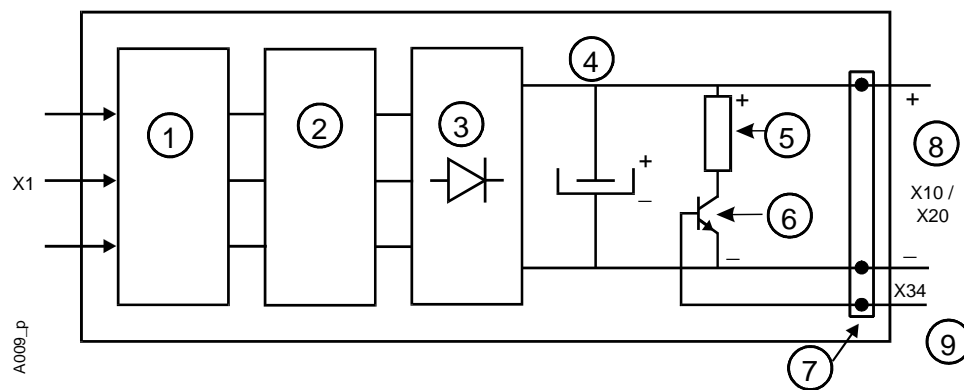

Figure 11. Block diagram of power supply section of AC supplied DMC².

- | | |
|------------------------------|--|
| 1. Internal EMC filter. | 2. Inrush current protection. |
| 3. Rectifier. | 4. Storage capacitor. |
| 5. Dynamic brake resistance. | |
| 6. Dynamic brake switch. | 7. Internal connection to converter section. |
| 8. DC Bus. | 9. To dynamic brake control. |

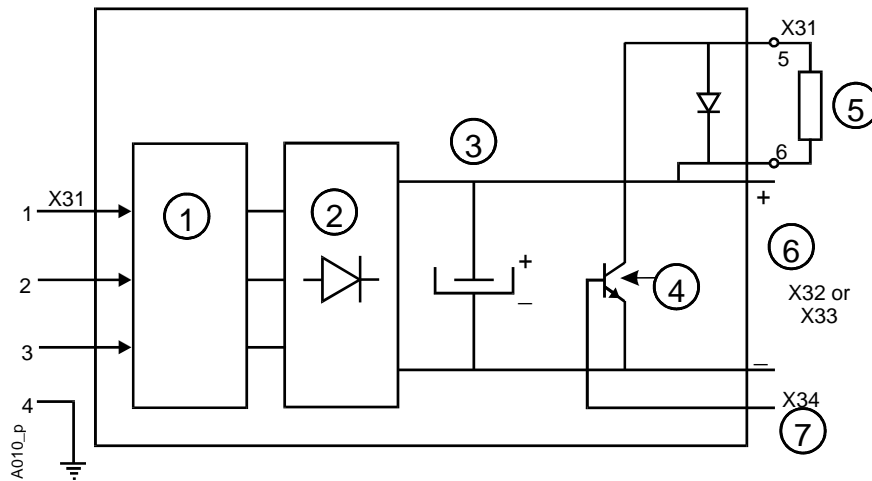

Figure 12. Block diagram of power supply section of stand-alone power supply.

- | | |
|------------------------------|--------------------------------|
| 1. Internal EMC filter | 2. Rectifier. |
| 3. Storage capacitor. | 4. Dynamic brake switch. |
| 5. Dynamic brake resistance. | |
| 6. DC Bus. | 7. From dynamic brake control. |

INTERNAL EMC FILTER

Attenuates conducted electrical noise into and out of power supply section.

INRUSH CURRENT PROTECTION

Limits the inrush current for protection of the rectifier diodes internally. This includes Contactors and switches externally.

RECTIFIER

Six-pulse rectification of the three-phase input power.

STORAGE CAPACITOR

Stores energy and filters the six pulse rectified voltage on the DC bus.

DYNAMIC BRAKE (REGENERATION, BLEEDER OR SHUNT CIRCUIT)

When Bus voltage rises to a pre-set level due to regeneration by the motor, the dynamic brake transistor is turned on allowing excess energy to be dissipated in the dynamic brake resistor.

DMC2 unit

CONVERTER SECTION

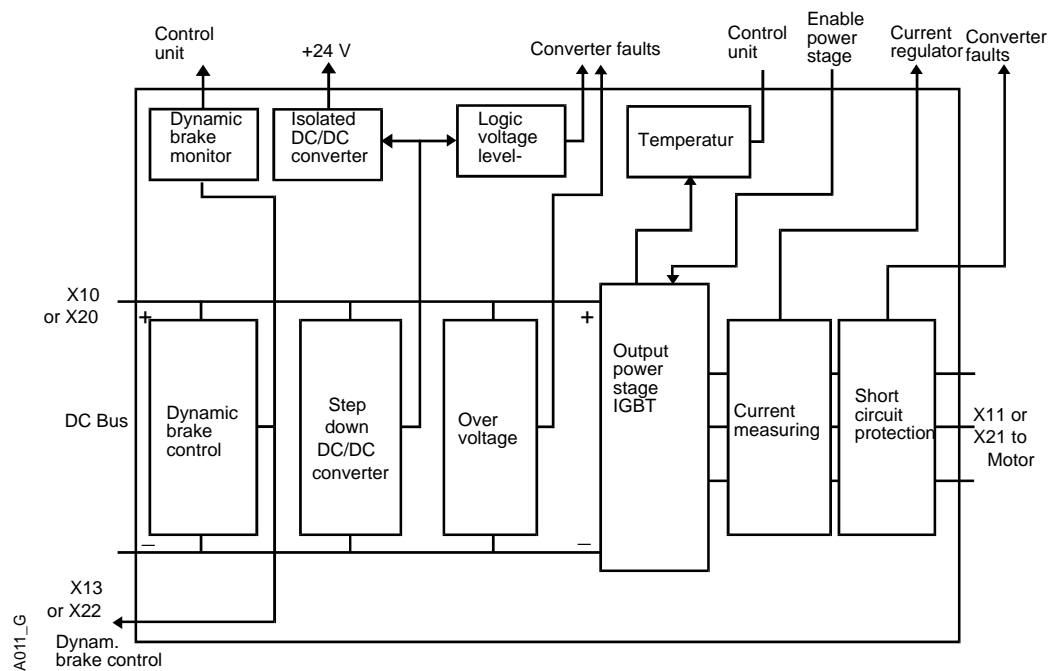

Figure 13. Converter Section, Block diagram.

SHORT CIRCUIT PROTECTION

Detects short circuits between motor windings and shorts to ground. Whenever current exceeds 300 % of the DMC²'s peak current rating for 10 ms, a short circuit protection fault occurs, immediately shutting down the output power stage. The short circuit detection is independent of the current measuring circuit.

TEMPERATURE (DRIVE OVER-TEMPERATURE PROTECTION)

Temperature sensor located in the output power stage, which sets an internal variable (Drive Temp High) whenever a drive over-temperature condition exists. The variable Drive Temp High can, in the application program, be used to shut down the output power stage.

OVER VOLTAGE LEVEL

Monitors the DC-bus voltage level. When the DC-bus voltage level is too high a over voltage level fault occurs, immediately shutting down the power stage.

LOGIC VOLTAGE LEVEL

Monitors the logic supply voltage level. When the logic voltage level is too low a logic voltage level fault occurs, immediately shutting down the power stage.

STEP DOWN DC/DC CONVERTER

Reduces the DC bus voltage to +24 V DC supply voltage for the logic.

ISOLATED DC/DC CONVERTER

Transform the +24 V DC supply voltage in the converter section to + 24 V DC supply voltage in the controller section with safe isolation.

CURRENT MEASURING

The current measurements are done in two motor phases with isolated current sensors able to measure AC, DC and impulse currents.

DYNAMIC BRAKE CONTROL (REGENERATION BLEEDER OR SHUNT CONTROL)

Controls the dynamic brake in the power supply section. When the DC bus voltage rises too high it will turn on the dynamic brake and turn it off when the voltage has reduced.

DYNAMIC BRAKE MONITOR

Measure the time the dynamic brake have been active and present it as a analog voltage that can be read from the software and used for overload detection.

SELECTING A DMC² FOR THE APPLICATION

PERFORMANCE SUMMARY AC SUPPLIED DMC²

[Table 3.](#) summarizes the principal performance characteristics of the available DMC² models with an integral AC power supply.

PERFORMANCE SUMMARY DC SUPPLIED DMC²

[Table 4.](#) summarizes the principal performance characteristics of the available DMC² models without an integral AC power supply.

STAND-ALONE POWER SUPPLIES, PS UNITS

When configuring a PDS with multiple DMC²s the optimum configuration is frequently a stand-alone power supply with DC supplied DMC²s. [Table 5](#) summarizes the principal performance characteristics for the available models of stand-alone power supply.

CONNECTOR KIT FOR DMC²

Input power, DC Bus power, motor, Dynamoc brake, Termistor/brake, Temperature switch, +24 V DC and I/O connections to the DMC² are made using transition connectors who mate with header type connectors on the DMC². [Table 6.](#) lists part numbers for these transition connectors along with mating DMC² connector kit designed for each model of the DMC².

Cabling

CABLING

POWER CABLE

Power cables shall be chosen so that national electrical regulations are fulfilled in the country where the system is to be used. We recommend that the power cable be sized for 2 times the fused current or at least 1.5 mm^2 .

MOTOR CABLE

Motor cables shall be chosen so that national electrical and EMC regulations are fulfilled in the country where the system is to be used. We recommend that the motor cable be sized for 2 times the continuous motor current or at least 1 mm^2 . [Table 7.](#) and [Table 8.](#) lists some motor cables available from us. A complete motor cable installation requires a threaded strain relief to be mounted on the motor junction box.

[Table 9.](#) lists strain relief's for the motor cable types listed in [Table 7.](#) and [Table 8.](#)

RESOLVER CABLE

Resolver cables shall be chosen so that national electrical and EMC regulations are fulfilled in the country where the system is to be used. We recommend resolver cables with shielded pair twisted conductors with an external common shield and an area of at least 0.25 mm^2 .

If cables recommended by us are used, electrical and EMC regulations within EC and USA are fulfilled. We supply completed resolver cable assemblies in various lengths as well as un-terminated cable, which may be ordered in custom lengths. [Table 10.- Table 13.](#) lists available resolver cable selections. [Table 14.](#) and [Table 20.](#) lists available resolver cable accessories.

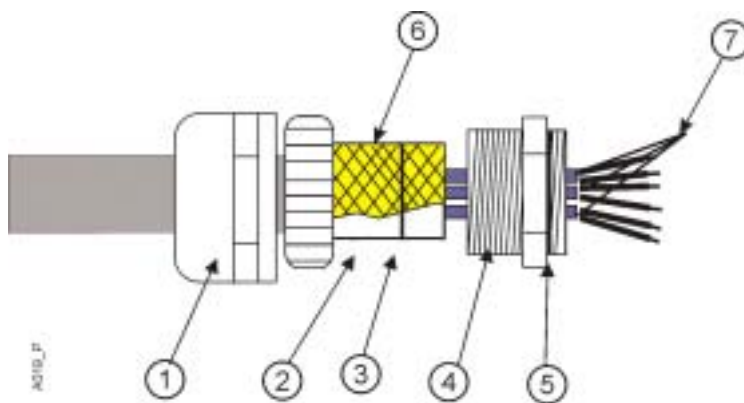

Figure 14. EMC shield with Hummel strain relief.

- | | | |
|--------------------|-------------|----------------|
| 1. Cap. | 2. Insert. | 3. O-Ring . |
| 4. Connecting nut. | 5. Sealing. | 6. EMC shield. |
| 7. Shield. | | |

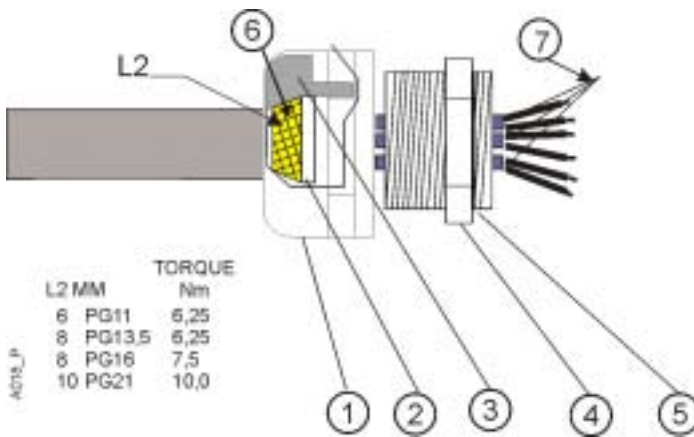

Figure 15. EMC shield with Pflitsch strain relief.

- | | | |
|--------------------|-------------|---------------------|
| 1. Cap. | 2. Insert. | 3. Clamping sleeve. |
| 4. Connecting nut. | 5. Sealing. | 6. EMC shield. |
| 7. Shield. | | |

COMMUNICATION CABLE

Cable assemblies for DMC² to PC and DMC² to DMC² interconnection are listed in [Table 15.](#) and [Table 16.](#) The DMC² to PC cables use a F 9 pin DSUB and 9 pol metal housing on the PC end. Cable assemblies for DMC² to Terminal PC are listed in [Table 17.](#)

CONTROL CIRCUIT CABLE

Shall be chosen so that national electrical regulations are fulfilled in the country where the system is to be used. We recommend that the control circuit cable having a cross-section of at least 0.5 mm² (AWG20).

FUSES

REQUIREMENTS

Fuses shall be chosen so that national electrical regulations are fulfilled in the country where the system is to be used. We recommend time delay fuse with a delayed opening of approximately 1 min total delay for 1.5 to 2 times rated current. [Table 2](#) below lists the fuse ratings for the various DMC² models.

If a circuit breaker is used, it must have a current interrupting capacity 6000 A and a delayed opening of approximately 1 min total delay for 1.5 to 2 times rated current of the DMC². If a circuit breaker is used, it should be used in conjunction with 100 amp fuses.

EMC filters

DMC ² Type	Time Delay Fuse Rating	Circuit Breaker Rating
DMC ² 50412P	6-8 A	6-8 A
DMC ² 50720P	6-8 A	6-8 A
DMC ² 51540P	10-16 A	10-16 A
PS380160	10-50 A	10-50 A
PS580160	10-50 A	10-50 A

Table 2 Fuse/circuit breaker ratings for DMC² models.

EMC FILTERS

REQUIREMENTS

EMC filters shall be chosen so that national electrical regulations are fulfilled in the country where the system is to be used. The filters used shall be tested to comply with the EMC regulations. We recommend the filters listed in [Table 21](#), which have been tested together with the DMC² unit. For filter dimensions, see part C.

CONTACTORS

One or two different types of contactors may be required depending on the system configuration:

- All system configurations use a main contactor. Paragraph "Main contactor selection" provides guidelines for main contactor selection. [Table 22](#).
- Systems utilizing a stand-alone power supply require an additional contactor, which inserts inrush current limiting resistance into the in feed circuit for the first 50 ms. after power-up. Paragraph "Inrush current contactor selection" provides guidelines for inrush current contactor selection. [Table 23](#).
- For Inrush Resistor, See [Table 24](#).

MAIN CONTACTOR SELECTION

- Use 4-pole contactors.
- The contactor's working current for AC1-operation at 40°C ambient temperature shall be equal or greater than 125 % of rated rms current for the input power fuses.
- The make current shall be lower than the contactors rated make current capacity.
- Operating rated voltage shall be +24 V DC or the voltage that are used for the auxiliaries' circuit.

INRUSH CURRENT CONTACTOR SELECTION.

- The contactor shall have a time delay on make of at least 10 ms.
- The contactor's working current for AC1-operation at 40°C ambient temperature shall be equal or greater than 125 % of rated rms current for the input power fuses.

- The make current shall be lower than the contactor's rated make current capacity.
- Operating rated voltage (50 or 60 Hz) shall be not less than the line-to-line voltage of the AC input voltage.

EXTERNAL DYNAMIC BRAKE RESISTORS

Select a power wire wound resistor type Dale HL or similar that are rated 1.5 TIMES the continuous dynamic brake power that are needed. This type of resistor is enabling to handle a peak power 50 TIMES its rated power in 1 second.

- Calculate needed power rating on the resistor.
- Calculate the peak power for 1 second.
- Calculate the max peak current for 700 V at the DC-bus.
- Calculate the resistance value.
- Check that maximum peak current and continuous current for the dynamic brake in the PS unit not are exceed.
- If the peak current is to low, select a resistor with higher power rating and calculate again.

EXAMPLE 1. CONTINUOUS POWER, 130W AND PEAK POWER 8kW.

Calculate needed power rating on the power resistor:

$$1,5 \times 130W = 200 W$$

Calculate peak power for 1 second:

$$200 \times 50 = 10 kW$$

Calculate max peak current for 400 V DC-bus:

$$10 kW / 700V = 14.3 A$$

Calculate resistance value: $700V / 14.3A = 49 \Omega$

another way to calculate the external dynamic brake resistor is to go the opposite way.

First select the resistance as close as possible to the minimum resistans that is allowed for the shunt regulator. This will give the maximum dynamic brake peak power for the dynamic brake in the PS unit.

- Calculate the max peak current for 700 V at the DC-bus.
- Calculate the peak power for 1 second.
- Calculate the power rating for the resistor that could handle the peak power.
- Calculate the minimum continuous power that could be handled by the resistors.
- Check that the continuous power is sufficient for the application. If the calculated continuous power is much larger then what is needed in the application, try to reduce the peak power it will save cost on the power resistors.

EXAMPLE 2. FOR PS580160 MINIMUM RESISTANS 10Ω.

Calculate the max peak current for 700 V at the DC-bus:

$$700V / 10 \Omega = 70 A$$

Calculate the peak power for 1 second:

$$700V \times 70 A = 49 kW$$

Calculate the power rating for the resistor that could handle the peak power:

$$49 kW / 50 = 980 W$$

Calculate the minimum continuous power that could be handle by the resistor:

$$980W / 1,5 = 653W$$



Peak power for 1 second in Watt is the same as pulse energy in Joule,
 $J = W/s$

TRANSFORMER SELECTION

In some application it is a need for transformer to convert the input voltage or for safety reasons.

Requirements on the transformer for a typical servo application with acceleration and deceleration peak torque of 2-3 times the continues torque:

- The output voltage should be 400 V AC.
- The transformers that have a continuous power rating equal our higher than the total continuous output power needed for the application.
- The transformer shall have a maximum of 5 % voltage drop at two times the continuous output power needed for the application.

EXAMPLE OF SYSTEM CONFIGURATIONS

DRIVE COMBINATION

To give good performance in dynamic applications should the drive-motor combination be able to give 2 to 3 times the rated torque at rated speed. The drive applications that are listed in [Table 25](#) and [Table 26](#) shows the components that are essential for an application.

They are optimized to take out the maximum of performance of drive and motor in a dynamic application.

SIZING COMPONENTS OF THE DMC² SYSTEM

- Calculate torque, power requirement and regeneration power requirement for the application.
- Choose motor, which satisfies torque, peak torque, and speed requirements.
- Choose DMC² unit with required continuous current, peak current and regeneration energy dissipation capacity.
- Choose cables and accessories, which satisfy voltage and current requirements and national electrical regulations.
- Overload Protection of the DMC² System.
- Use a motor that can handle a specified overload current and an overload protection device that activates before the specified overload is exceeded.
- Use a motor cable that can handle a current higher than the specified overload current for the motor.
- Connect the over-temperature protection device in the motor to the motor temperature input on the DMC² unit.
- Set the current limiting parameter `Reg.TorqLim` in the DMC² unit to the specified overload current for the motor. Use the internal variable for Current Regulator fault to shut down power stage in the DMC² unit if actual current measured in motor phases differs from command current.
- Use the internal variable for `Motor.TempHigh` to shut down the power stage in the DMC² unit if the motor overload protection device is activated.

DMC² Tables

PERFORMANCE SUMMARY AC SUPPLIED DMC².

Table 3

Order No 9032	AC Supply Models DMC ²	Input voltage 50/60Hz VCA	Input current A _{rms}	Output cont. current A _{rms}	Output peak current A	Output cont. power kW	Power loss W ¹⁾	Max cont. DC-bus current A ²⁾	Dynamic brake current A	Dynamic brake max. energy one pulse kJ	Dynamic brake cont. power W	Width mm	Weight kg	
0121 28	50412P	3x400	3	3	12	1.9	90	7	18.7	10	40	76	3.8	
0121 42	50412P-CAN													
0121 30	50720P	3x400	5	5	20	3.4	90	7	18.7	10	40	76	3.8	
0121 44	50720P-CAN													
0121 32	51540P	3x400	11	11	40	7.4	155	14	18.7	20	80	160	6.8	
0121 46	51540P-CAN													
1) Not including dynamic breaking power loss														
2) Including internal current to output power														

PERFORMANCE SUMMARY DC SUPPLIED DMC².

Table 4

Order No 9032	DC Supply Models DMC ²	Input voltage V DC	Cont. current A DC	Cont. current A _{rms}	Peak current A	Cont. output power kW	Power loss W	Width mm	Weight kg
0121 20	50412	570	3.5	3	12	1.9	60	46	2.7
0121 34	50412-CAN								
0121 22	50720	570	6	5	20	3.4	60	46	2.7
0121 36	50720-CAN								
0121 24	51540	570	13	11	40	7.4	115	122	5.1
0121 38	51540-CAN								
0121 26	53080	570	25.5	21	80	14.5	190	173	7.5
0121 40	53080-CAN								

PERFORMANCE SUMMARY STAND-ALONE POWER SUPPLIES, PS UNITS.

Table 5

Order No 9032	Power Supply Models PS	Input voltage 50 / 60 Hz V AC	Input current A _{rms}	Output cont. current A DC	Output peak current A DC	Output cont. power kW	Power loss W ¹⁾	Dynamic brake peak current A	Dynamic brake cont. current A	Dynamic brake max energy one pulse kJ	Dynamic brake cont. power W	Width mm	Weight kg
0101 01	580160	3x400	65	80	160	45.5	180	70	35	note 1	note 1	173	7.2
¹⁾ Depends on rating for the external dynamic brake resistor.													

CONNECTOR KIT FOR DMC²

Table 6

Order No Connection function	Name Phoenix	DMC ² connector designation	DMC ² 50412P 50720P	DMC ² 50412P 50720P	DMC ² 50412 50720	DMC ² 51540P	DMC ² 51540P	DMC ² 51540 53080	PS 580160
			Single	Master	Slave	Single	Master	Slave	
Power									
20D604B ¹⁾	GMSTB 2.5/4-ST-7.62	X1	1	1					
20D504R	PC4 HV/4-ST-7.62	X1	1	1		1	1		
Motor									
20D505Q	PC 4/5-ST-7.62	X11	1	1	1				
20D509Q	PC 4/9-ST-7.62	X21				1	1	1	
DC Bus									
20D503Q	PC 4/3-ST-7.62	X10		1	1				
20D506Q	PC 4/6-ST-7.62	X20, X32, X33					1	1	2
Dynamic brake									
20D503I	IC 2.5/3-ST-5.08	X13, X22, X34							2
Termistor / brake									
20D505B	MSTBA 2.5/5-ST-5.08	X14, X23	1	1	1	1	1	1	
Input and Output									
20D516S	MC1.5/15-ST-3.81	X7A	1	1	1	1	1	1	
19N017A	MC1.5/15-ST-3.81	X7B	1	1	1	1	1	1	
Temp. switch									
20D502A	MSTBA 2.5/2-ST-5.08	X35							1
+24Volt Extenal DC									
20D602B	GMSTB 2.5/2-ST-7.62	X2	1	1	1	1	1	1	
Connector Kit No			9032 0119 70	9032 0104 94	9032 0103 53	9032 0104 95	9032 0103 52	9032 0104 96	9032 0108 51

¹⁾20D604B This connector is only for DMC delivered before Feb 2001.

MOTOR CABLE, COMBI CY

Table 7

Order No	Name	No of leads	Current rating EN60204 A	Voltage rating V	Temp- erature °C	Motor leads area mm ²	Bend radius mm	Strain reliefs	Diameter ∅ mm	DC resistance mΩ/m	Capacitance conductor to shield pF/m	Shield coverage
27M012A	MC-COMBICY-1,0	4x1+2(2x0,25)	9.6/11.7	500	-5 to +70	1	5x∅	19N308A	12.7	19.5	200	82%
27M010D	MC-COMBICY-2,5	4x2,5+2(2x0,75)	16.5/21	500	-5 to +70	2.5	15x∅	19N310A	16	7.98	220	80%
27M014A	MC-COMBICY-4,0	4x4+(2x1)+(2x0,75)	23/28	500	-5 to +70	4	15x∅	19N310A	17	4.95	250	80%
27M735A	MC-COMBICY-2x4,0	8x4+2x(2x1)	2x23 / 2x28	500	-5 to +70	2x4	15x∅	19N310A	21.5	4.95	225	80%

HIGH FLEX MOTOR CABLE, EUROFLEX S 801 C

Table 8

Order No	Name	No of leads	Current rating EN60204 A	Voltage rating V	Temp- erature °C	Motor leads area mm ²	Bend radius mm	Strain reliefs	Diameter ∅ mm	DC resistance mΩ/m	Capacitance conductor to shield pF/m	Shield coverage
27M720A	MC-S801C-1.0	4x1+2(2x0.25)	9.6/11.7	750	-40 to +70	1	12x∅	19N308A	10.9			
27M721A	MC-S801C-2.5	4x2,5+2(2x0,75)	16.5/21	750	-40 to +70	2.5	12x∅	19N310A	14			
27M722A	MC-S801C-4.0	4x4+(2x1)+(2x0,75)	23/28	750	-40 to +70	4	12x∅	19N310A	16			
27M725A	MC-S801C-2x4.0	8x4+2x(2x1)	2x23/2x28	750	-40 to +70	2x4	12x∅	19N310A	21.1			

STRAIN RELIEFS FOR MOTOR CABLE

Table 9

Order No	Name	Pg	Cable diameter mm ∅		L2 mm
19N308A	HSK-M-EMV	21	13-18	Hummel	
19N309A	HSK-M-EMV	21	19-16	Hummel	
19N310A	HSK-M-EMV	29	13-20	Hummel	
19N300A	MCC-EP-PG16/1.0	16	12-15	Pflitsch	6
19N301A	MCC-EP-PG16/1.0	16	14-17	Pflitsch	8
19N302A	MCC-EP-PG16/1.0	16/21	16-20	Pflitsch	8
19N303A	MCC-EP-PG16/1.0	21	16-20	Pflitsch	10

RESOLVER CABLES WITH CONNECTORS FOR EP MOTORS

Table 10

Order No	Name	Type of cable	Cable area mm ²	Length m	Temp rating °C	DMC contact	Motor contact	Bend radius	Diameter mm Ø
27M017B	RC-DMC-EP-5	Shielded with three twisted and shielded pairs	0.25	5	-5 to +70	19N117K	19N117R + 19N304A	7.5xØ	9.9
27M017C	RC-DMC-EP-7.5		0.25	7.5	-5 to +70	19N117K		7.5xØ	9.9
27M017D	RC-DMC-EP-10		0.25	10	-5 to +70	19N117K		7.5xØ	9.9
27M017E	RC-DMC-EP-15		0.25	15	-5 to +70	19N117K		7.5xØ	9.9

RESOLVER CABLES WITH CONNECTORS FOR SEM MOTORS

Table 11

Order No	Name	Type of cable	Cable area mm ²	Length m	Temp rating °C	DMC contact	Motor contact	Bend radius	Diameter mm Ø
27M030B	RC-DMC-AHD-5	Shielded with three twisted and shielded pairs	0.25	5	-5 to +70	19N117K	19N410A + 20B231A (8 pcs) + 19N305A	7.5xØ	9.9
27M030C	RC-DMC-AHD-7.5		0.25	7.5	-5 to +70	19N117K		7.5xØ	9.9
27M030D	RC-DMC-AHD-10		0.25	10	-5 to +70	19N117K		7.5xØ	9.9
27M030E	RC-DMC-AHD-15		0.25	15	-5 to +70	19N117K		7.5xØ	9.9

RESOLVER CABLES, BY THE METER

Table 12

Order No	Name	Type of cable	Cable area mm ²	Length m	Temp rating °C	Bend radius	Diameter mm Ø
27M013A	RC-LIYCY-0.25	Shielded with three twisted and shielded pairs	0.25	By the meter	-5 to +70	7.5xØ	9.9

HIGH FLEX RESOLVER CABLES

Table 13

Order No	Name	Type of cable	Cable area mm ²	Length m	Temp rating °C	Bend radius	Diameter mm Ø
27M015A	RC-LY12Y11Y-0.25	Shielded with three twisted and shielded pairs	0.25	By the meter	-40 to +70	7.5xØ	10

STRAIN RELIEFS FOR RESOLVER CABLE

Table 14

Order No	Name	Pg	Cable diameter mm Ø		L2 mm
19N305A	HSK-M-EMV	11	5-10	Hummel	
19N304A	MCC-EP-PG11	11	6-10	Pflitsch	10

COMMUNICATIONS CABLES DMC² - PC

Table 15

Order No	Name	Length m	No of leads	Cable area mm ²	Shield
27M117A	CC-DMC-RS232-2	2	3	0.25	Yes
27M117B	CC-DMC-RS232-4	4	3	0.25	Yes

COMMUNICATIONS CABLES DMC² - DMC²

Table 16

Order No	Name	Length m	No of leads	Cable area mm ²	Shield
27M217A	CC-DMC-DMC-0.2	0.2	9	0.25	Yes
27M217B	CC-DMC-DMC-0.3	0.3	9	0.25	Yes

COMMUNICATIONS CABLES DMC² – TERMINAL PC

Table 17

Order No	Name	Length m	No of leads	Cable area mm ²	Shield
27M127A	CC-PC-DMC-3	3	9	0.25	Yes
27M127B	CC-PC-DMC-5	5	9	0.25	Yes
27M127D	CC-PC-DMC-1.5 Angle	1.5	9	0.25	Yes

SYNC CABLE

Table 18

Order No	Name	Length m	No of leads	Cable area mm ²	Shield
27M425A	Syncbox Cable	0,7	12	0.25	Yes

DMC² SYNCBOX

Table 19

Order No	Name	No of connectors		
27M425B	DMC Syncbox External resolver	3	EP MOTOR	
27M425C	DMC Syncbox Master / Slave	4	EP MOTOR	
27M425D	DMC Syncbox Master / Slave	8	EP MOTOR	
27M425E	DMC Syncbox External resolver	7	EP MOTOR	
9032 0108 80	DMC Syncbox External resolver	3	SEM MOTOR	2 pol resolver
9032 0108 81	DMC Syncbox External resolver	3	SEM MOTOR	6 pol resolver

CONNECTOR.

Table 20

Order No	Name	Remark	No of pin		Connector
9032 0103 17	Connector, female	D-SUB incl. hood	9	For external rotary	
9032 0103 18	Connector, male	D-SUB incl. hood	9	For external rotary	
9032 0103 14	CAN termination				FBU and CAN communication X4/X5
9032 0103 15	CAN termination			With external connection	FBU and CAN communication X4/X5
19N117K	Connector, male	D-SUB incl. hood	15	For resolver cable at DMC	X6A
19N117R	Connector, Burndy		8	For resolver cable at EP motor	
19N410A	Connector, AMP	Contact 20B231A (8pcs)	8	For resolver cable at SEM motor	
19N117A	Connector kit	4-10A incl. D-sub	9 pcs.		
19N117B	Connector kit	15-20A incl. D-sub	9 pcs.		

RECOMMENDED EMC FILTERS

Table 21

Order No	Name	Rated current (50_C) I_{rms}	Leakage current (230V/50Hz) mA	Power loss W	Weight Kg	Input connection	Output connection	Recommended for DMC ²
56S117A ¹⁾	FN251-8-07	8	1.31	7	0.75	Cable AWG16	Cable AWG16	50412P + 50720P
9032 0118 31	FN258-7/07	7	71	4.5	1.1	Cable AWG16	Cable AWG16	50412P + 50720P
56S117B ¹⁾	FN251-16-07	16	1.31	14	1.8	Cable AWG14	Cable AWG14	51540P
9032 0118 32	FN258-16/07	16	84	9	1.7	Cable AWG16	Cable AWG16	51540P
56S117C	FN351-50-33	50	190	13	3.1	Cable AWG6	Cable AWG6	53080+PS580160
56S117F	FN258-30/07	30	104	14	1.8	Cable AWG10	Cable AWG10	PS580160
56S117G	FN258-75/34	75	113	20	4	Cable AWG3	Cable AWG3	PS580160
¹⁾ 56S117A, 56S117B is second hand choice.								

RECOMMENDED MAIN CONTACTORS

Table 22

Name	Current rating, AC1 operating A	Supply voltage V DC	Fuses A	Recommended for 400 V AC application with maximum rated cont. output power kW
Type Telemecanique LP1-D25004BD	25	24	16	11
Type Telemecanique LP1-D25004BD	40	24	32	22

RECOMMENDED INRUSH CURRENT CONTACTORS

Table 23

Name	Current rating, AC1 operating A	Supply voltage V AC	Fuses A	Recommended for application with maximum rated cont. output power kW	Recommended inrush resistor
Type Telemecanique LC1-D12004Q5	25	400	16	11	4.7Ω/50W
Type Telemecanique LC1-D25004Q5	40	400	32	22	4.7Ω/50W

RECOMMENDED INRUSH RESISTORS

Table 24

Name	Rating	Inrush Current limit at 400 V AC
Type example (DALE HL 50)	4.7Ω/50W	120 A

SYSTEM CONFIGURATION DMC²

SYSTEM CONFIGURATIONS 400 VAC

Table 25

Motor-Drive combination	Power Supply	Motor Cable 15m	Motor Cable strain relief	Resolver Cable with conn. 15 m	Filter	Fuse	Power Cable rating	Main Cont. curr. rating A	Inrush Curr. cont.	Inrush resistor	Dynamic brake resistor
DMC ² 50412P	inbuilt	27M012A	19N300A	27M017E	56S117A	6	10 A → AWG16	10	inbuilt	inbuilt	inbuilt
DMC ² 50412P	inbuilt	27M012A	19N300A	27M017E	56S117A	6	10 A → AWG16	10	inbuilt	inbuilt	inbuilt
DMC ² 50720P	inbuilt	27M010D	19N301A	27M017E	56S117A	6	10 A → AWG16	10	inbuilt	inbuilt	inbuilt
DMC ² 51540P	inbuilt	27M010D	19N301A	27M017E	56S117B	16	20A → AWG14	25	inbuilt	inbuilt	inbuilt
DMC ² 53080	PS580160	27M014A	19N303A	27M017E	56S117C	25	40A → AWG8	40	40	4.7Ω/50W	10Ω/1000W

RATING FOR SYSTEM CONFIGURATIONS 400 VAC

Table 26

Motor / Drive combination	Rated torque Nm	Peak torque at rated speed Nm	Max. peak torque (at 150 rpm) Nm	Rated speed rpm	Rated power kW	Peak power at rated speed kW	Dynamic brake max. energy one pulse kJ	Dynamic brake cont. power W	Rotor inertia kgm ² x 10 ⁻³
EP075112-44T3B / DMC ² 50412P	1.7	5.5	8.5	3000	0.53	1.7	6.5	40	0.13
EP115052-66T3B / DMC ² 50412P	2.1	5.5	9	3000	0.66	1.7	6.5	40	0.29
EP115105-66T3B / DMC ² 50720P	3.8	13.5	15	3000	1.3	4.2	6.5	40	0.47
EP165090-66T3B / DMC ² 51540P	9	25	26	3000	2.8	7.8	7.8	80	1.67
EP165180-66T3B / DMC ² 53080	16	59	65	3000	5	18.5	10.4	150	3.01

DMC² Connections

GENERAL

This section provides details for connecting the DMC² to motor connections, power, dynamic brake, thermistor /brake, DC Bus, I/O, Daisy chain, LAN 2 and integral resolver.



The motor cable connector nomenclature and location is different for the various DMC² models.



WARNING

- ◆ Failure in properly ground this equipment could result is serious or fatal injury to personnel who come into contact with the equipment. All earth grounds must be installed per the instructions in this chapter, and the equipment must be securely connected to a quality earth ground before power is applied for the first time. In addition, the panel or enclosure housing the equipment must be securely earth grounded.
- ◆ Local regulations may require additional grounding measures beyond those shown in this chapter.
- ◆ Failure to properly ground the equipment may result in damage to the equipment or damage to other devices connected to the equipment.



WARNING

- ◆ This equipment uses high voltages, which can cause serious or fatal electrical shock.
- ◆ Can cause serious or fatal injury.
- ◆ Only qualified personnel should perform installation and wiring.

X Connector's

X CONNECTOR'S

Connector	Function	Interface	page
X1	Input power		51
X2	+ 24 V External DC		52
X4	Host	RS 232, RS 422, LAN 1, X5	52
X5	Next	RS 232, RS 422, LAN 1, X4	53
X6A	Resolver Feedback		54
X6B	Optional Position Sensor	Available only for DMC ² CAN	56
X7A	I/O		57
X7B	I/O		57
X8A	Measure connection	Available only for DMC ² CAN	61
X9	LAN 2	Available only for DMC ² CAN	62
X10	DC Bus	X10P, X32, X33	62
X11	Motor		62
X13	Dynamic brake	X34	63
X14	Thermistor/brake	X35	63
X20	DC Bus	X20P, X32, X33	64
X21	Motor		64
X22	Dynamic brake	X34	65
X23	Thermistor/brake	X35	65
X31	Input power		66
X32	DC Bus	X10, X20	66
X33	DC Bus	X10, X20	66
X34	Dynamic brake	X13, X22	67
X35	Thermistor/brake Temperature switch	X14, X23	67

DSUB CONNECTOR'S

Connector	D-Sub miniature in Metal housing	Pin	Male	Female
X4 and X5	High Density, VGA	15		X
X6A	Standard	15		X
X6B	Standard	25		X
X8A	Standard	9	X	
X9	Standard	9	X	

DMC² FRONT

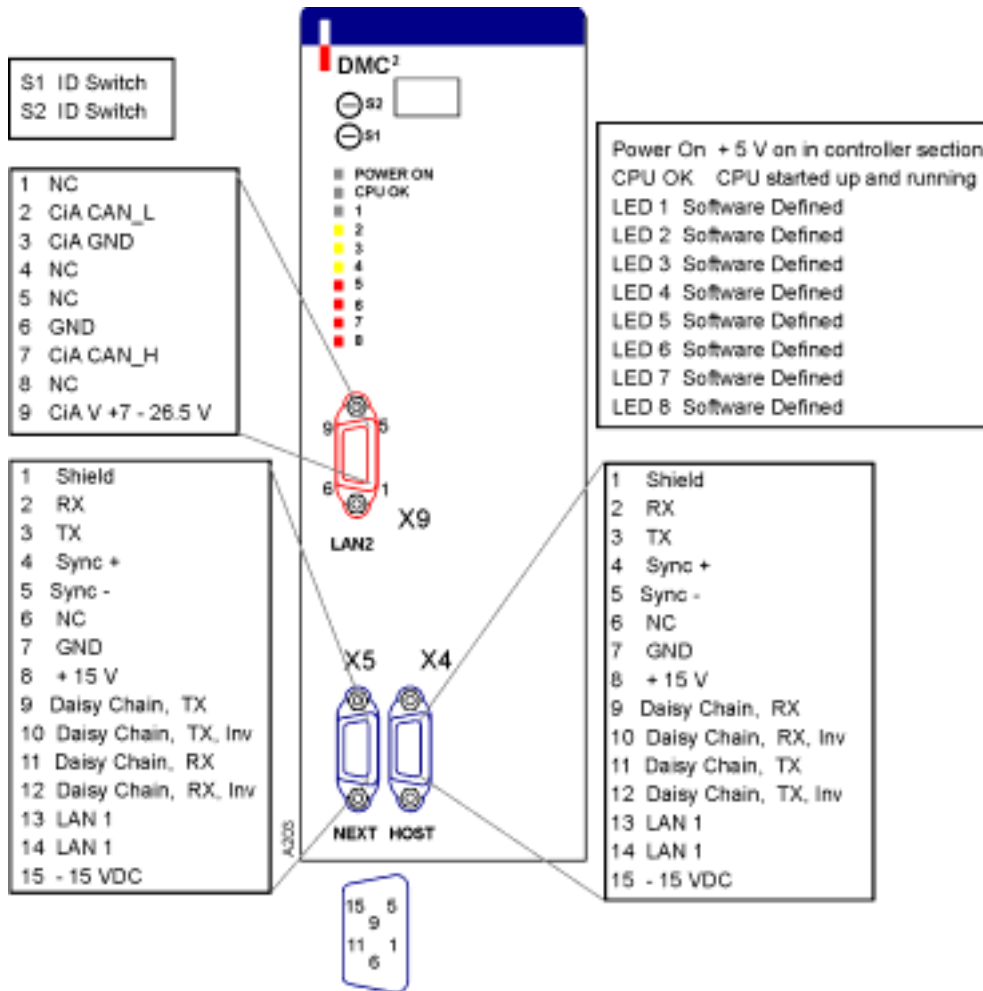

Figure 16. DMC² Front and Connections.

DMC2 I/O Connections

DMC² I/O CONNECTIONS

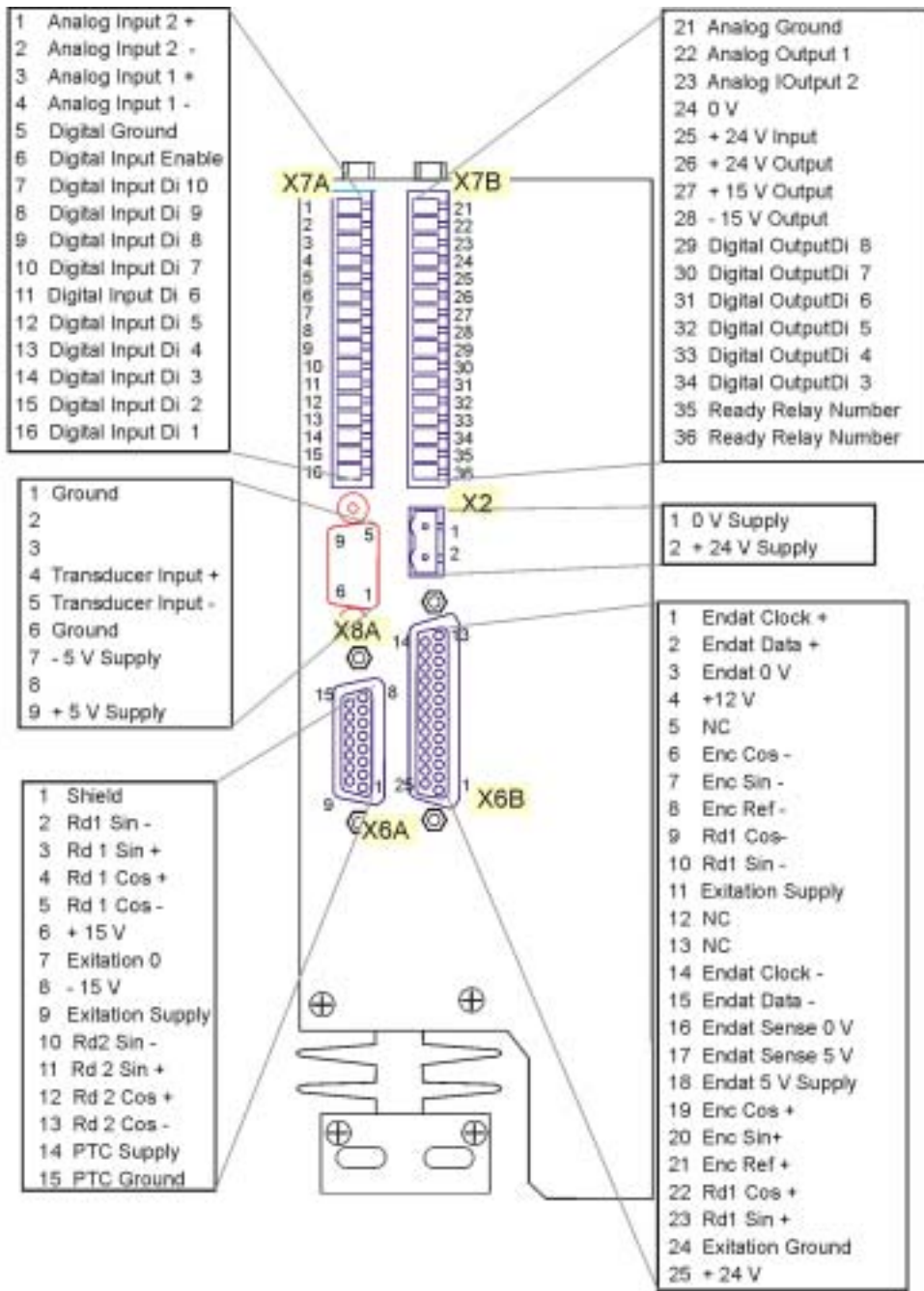

Figure 17. I/O Connections for all DMC² units, bottom view.

DMC² 50412/P, DMC² 50720/P

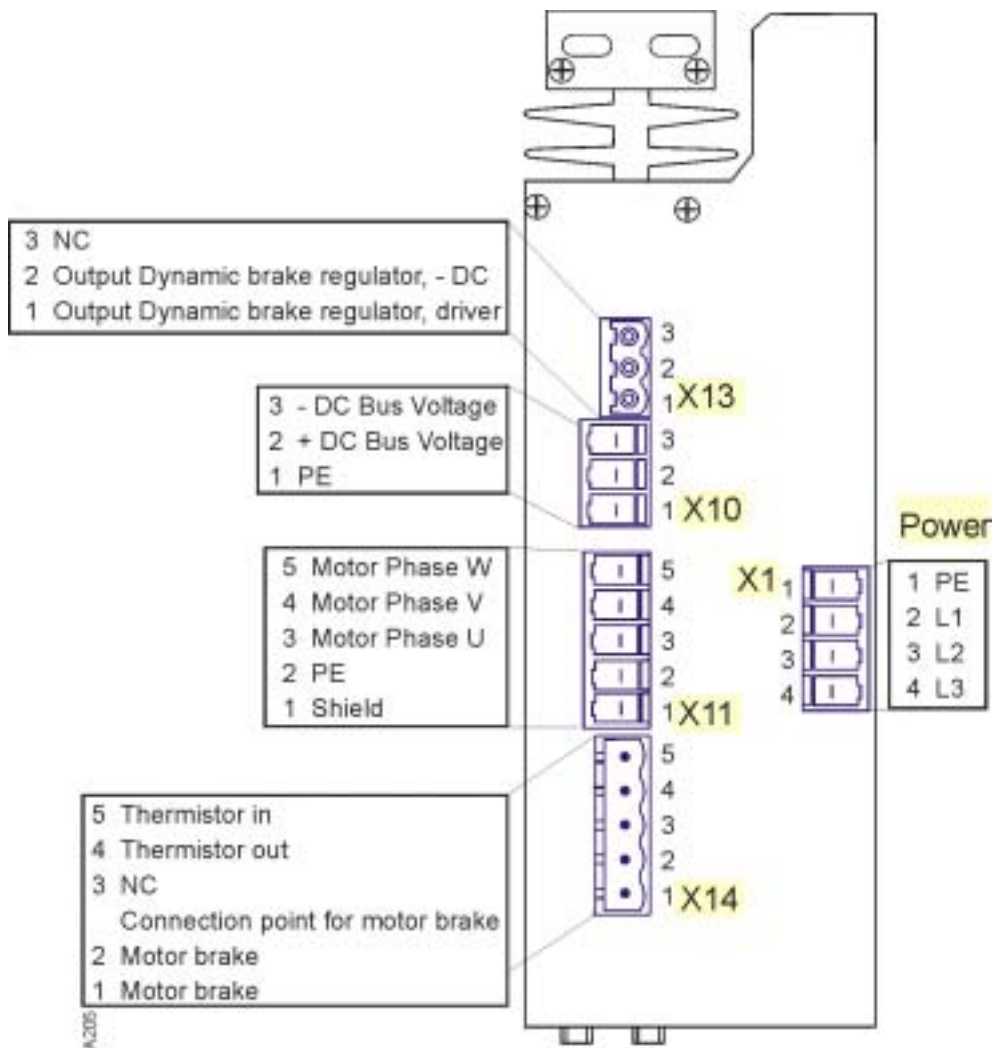

Figure 18. DMC² unit connectors on the topside, Motor, Power, Thermistor, DC Bus for 50412/P and 50720/P.

DMC2 51540/P, DMC2 53080

DMC² 51540/P, DMC² 53080

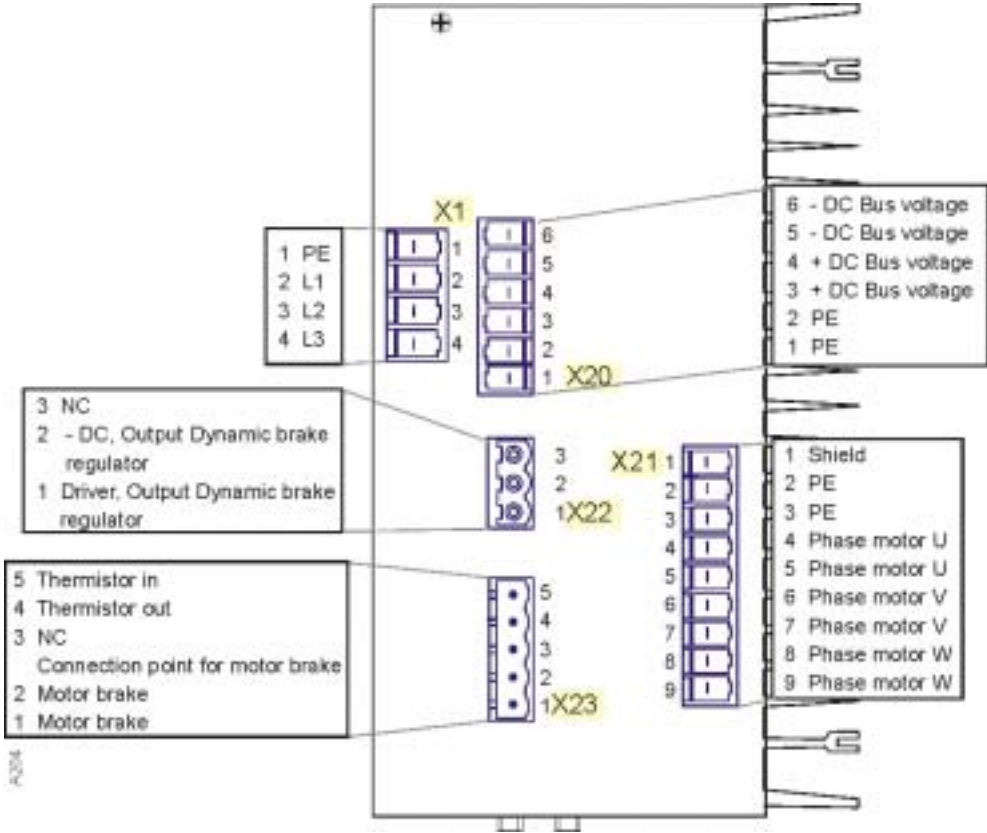

Figure 19. DMC² unit connectors on the topside, Motor, Power, Thermistor, DC Bus for 51540/P and 53080.

POWER SUPPLY 580160

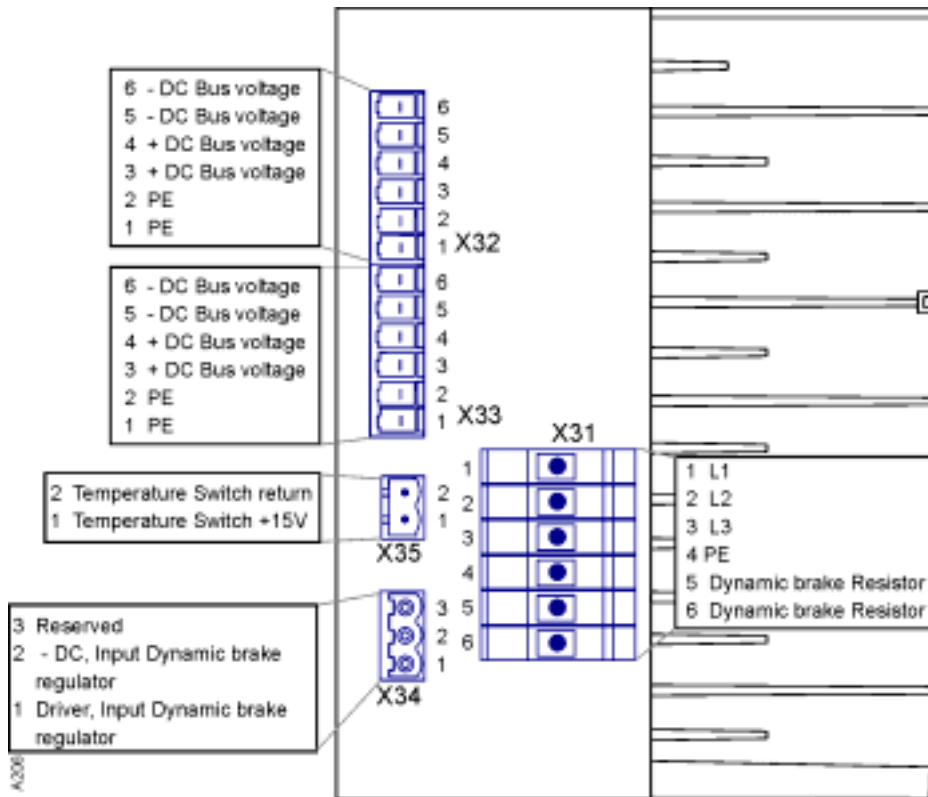

Figure 20. PS 580160 unit connectors on top side, Power, Dynamic brake and Thermistor.

X1

DMC ² P	50412	50720	51540	
DMC ²	50412	50720	51540	53080
Connector	See page			

Input power is connected to X1 Figure 18 or Figure 19 on top of the DMC² unit as shown in Figure 29 for a Single and Figure 30 for a Master/Follower application.

Connect DMC²5xxxxP models to 400 VAC mains.

DMC ² X1	Function
1	PE
2	Phase L1
3	Phase L2
4	Phase L3

Table 27. Connection Mains to DMC².

X2

X2

DMC ² P	50412	50720	51540	
DMC ²	50412	50720	51540	53080
Connector	See page 35			

Connections for 24V-logic **external** supply voltage. When connected, it supplies the internal control circuit, feedback sensors, communication and I/O ports.

The 24V logic supply shall always be connected before the main supply voltage is connected to the input power port. External fuse shall be used rated max 1.5A T (slow).

DMC ² X2	Function	Remark
1	0 V Supply	Internal connected to X7A, pin 5
2	+ 24 V Supply, +20%: -20%, maximum supply current 0.7A (not including load on digital outputs)	Internal connected to X7B, pin 25

Table 28. External +24 V Connection to DMC².

X4 (HOST)

DMC ² P	50412	50720	51540	
DMC ²	50412	50720	51540	53080
Connector	See page 46			

X4 is used for connections between external PC and other DMC² units.



The maximum length for this cable is 15 m.

DMC ² X4 (Host)	Function
1	Shield
2	RX
3	TX
4	Sync+
5	Sync-
6	NC
7	GND
8	+15 V
9	Daisy Chain, RX
10	Daisy Chain, RX inv
11	Daisy Chain, TX
12	Daisy Chain, TX inv
13	LAN 1
14	LAN 1
15	-15 VDC

X5 (NEXT)

DMC ² P	50412	50720	51540	
DMC ²	50412	50720	51540	53080
Connector	See page	46		

X5 is used for communication between two or more DMC² and for LAN1 communication.

DMC ² X5 (Next)	Function
1	Shield
2	RX
3	TX
4	Sync+
5	Sync-
6	NC
7	GND
8	+15 V
9	Daisy Chain, TX
10	Daisy Chain, TX inv
11	Daisy Chain, RX
12	Daisy Chain, RX inv
13	LAN 1
14	LAN 1
15	-15 VDC

X4 AND X5 CONNECTION

RS 232 INTERFACE

The RS-232 interface is used when connecting a PC to the DMC². Connect the serial communication cable from the computer to X4 ([Figure 16.](#)).

DMC ² X4	Function	PC 9 Pin	PC 25 Pin
1	Shield		
2	RX	3	2
3	TX	2	3
7	GND	5	7

Table 29. Host (X4) Connection to RS 232 Interface.

COMMUNICATION BETWEEN DMC²

Connect the Daisy Chain cable from X5 ([Figure 16.](#)) on the first DMC² unit to X4 on the second DMC² unit ([Table 30.](#)).

X6A

DMC ² X4	Function	DMC ² X5
1	Shield	1
4	Sync +	4
5	Sync -	5
7	GND	7
9	Daisy chain Rx ↔ Tx	9
10	Daisy chain Rx Inv ↔ Tx Inv	10
11	Daisy chain Tx ↔ Rx	11
12	Daisy chain Tx Inv ↔ Rx Inv	12
13	LAN 1 High	13
14	LAN 1 Low	14

Table 30. Next (X5) Connection to Host (X4) on DMC².

LAN 1 COMMUNICATION

Connect the Daisy Chain cable from X5 on the first DMC² unit to X4 on the second DMC² unit (Figure 16.). Use the CAN termination 9032 0103 14 at the first DMC² in the application and a CAN termination with possibility to measure data 9032 0103 15 at the last DMC² in the application.

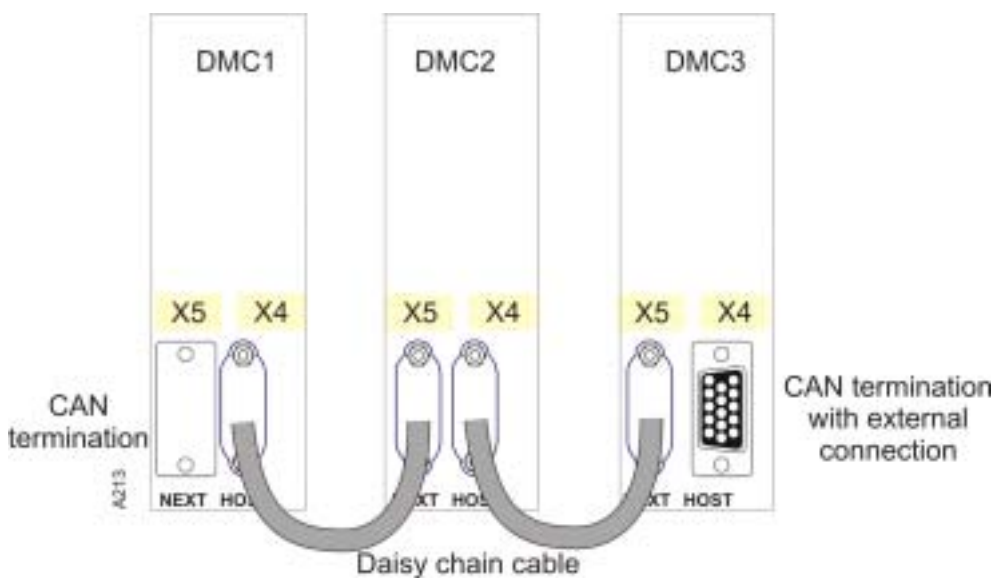

Figure 21. Typically LAN connection.

X6A

DMC ² P	50412	50720	51540	
DMC ²	50412	50720	51540	53080
Connector	See page	46		

This connector is used for resolver and external resolver connection. For location see Figure 17.

RESOLVER AND EXTERNAL RESOLVER CONNECTION

RESOLVER CONNECTION FROM MOTOR

On the DMC² end, connect the resolver cable to X6A. Use our connection set 19N117K. The connection on motor side is depending on the manufacturer of motor. It's therefore important to check the motor wiring diagram.

EXTERNAL RESOLVER

For input from an external resolver is Rd2 used and is connected to X6A on the DMC². See [Table 31](#).

DMC ² X6A	Function	Rd1	Rd2
1	Shield	X	
2	Rd1 Sin -	X	
3	Rd1 Sin +	X	
4	Rd1 Cos +	X	
5	Rd1 Cos -	X	
6	+15 V		
7	Ground	X	X
8	-15 V		
9	Excitation	X	X
10	Rd2 Sin -		X
11	Rd2 Sin +		X
12	Rd2 Cos +		X
13	Rd2 Cos -		X
14	PTC Supply		
15	PTC Return		

Table 31. External Resolver Connection.

SYNCBOX

At applications with more than one resolver is a syncbox necessary to use. Use a Syncbox cable to connect the DMC² with the Syncbox at X6A.

X6B

X6B

DMC ² P-CAM	50412	50720	51540	
DMC ² CAM	50412	50720	51540	53080
Connector	See page 46			

This connector could be used for the following sensors:

Sensor	Description
S1	Multiturn-Resolver with ENDAT serial interface.
S2	SinCos Encoder and Absolute SinCos Encoders with ENDAT serial interface.
S3	Incremental Encoder with index pulse, TTL interface and 5V supply.
S4	Pulse input, max input frequency 30 kHz.

DMC ² X6B	S1	S2	S3	S4	Function	Remark
1	X	X			Endat Clock+	ENDAT, RS485
2	X	X			Endat Data+	ENDAT, RS485
3	X	X	X		Endat 0 V	0 V supply; ENDAT or Encoder
4					+12 V	(+12 V Supply, 150 mA, not standard opt.).
5					NC	
6		X	X		Enc Cos-	ENDAT 1 Vpp or Encoder 5V TTL,120 ohm.
7		X	X		Enc Sin-	ENDAT 1 Vpp or Encoder 5V TTL,120 ohm.
8		X	X	X	Enc Ref-	ENDAT 1 Vpp or Encoder 5V TTL,120 ohm.
9	X				Rd1 Cos-	Internal connected to X6A:5
10	X				Rd1 Sin-	Internal connected to X6A:2
11	X				Excitation Supply	Internal connected to X6A:9
12					NC	
13					NC	
14	X	X			Endat Clock-	ENDAT, RS485
15	X	X			Endat Data-	ENDAT, RS485
16	X	X			Endat Sence 0 V	ENDAT, Voltage drop detection
17	X	X			Endat Sence 5 V	ENDAT, Voltage drop detection
18	X	X	X		Endat 5 V Supply	ENDAT, Max 300mA
19		X	X		Enc Cos+	ENDAT 1 Vpp or Encoder 5V TTL,120 ohm.
20		X	X		Enc Sin+	ENDAT 1 Vpp or Encoder 5V TTL,120 ohm.
21		X	X	X	Enc Ref+	ENDAT 1 Vpp or Encoder 5V TTL,120 ohm.
22	X				Rd1 Cos+	Internal connected to X6A:4
23	X				Rd1 Sin+	Internal connected to X6A:3
24	X				Excitation Ground	Internal connected to X6A:7
25					+24 V	(+24 V Supply, 150 mA, not standard opt.).

Table 32. Connection on X6B. X indicates used pin.

X7A/B

DMC ² P	50412	50720	51540	
DMC ²	50412	50720	51540	53080
Connector	See page	35		

All user connections to the DMC² I/O are made at X7A and X7B and [Figure 17](#) illustrates the location.

PINOUTS USER I/O

All user inputs and outputs are brought out to connectors X7A and X7B and are listed in [Table 33](#) below.

DMC ² X7A		DMC ² X7B	
	Function		Function
1	Analog input 2+	21	Analog GND
2	Analog input 2-	22	Analog output 1
3	Analog input 1+	23	Analog output 2
4	Analog Input 1-	24	Digital GND
5	GND	25	Input for +24 VDC external supply Parallel with X2:2
6	Digital input, HW enable	26	+24 VDC out
7	Digital input 10	27	+15 VDC out
8	Digital input 9	28	-15 VDC out
9	Digital input 8	29	Digital output 6
10	Digital input 7	30	Digital output 5
11	Digital input 6	31	Digital output 4
12	Digital input 5	32	Digital output 3
13	Digital input 4	33	Digital output 2
14	Digital input 3	34	Digital output 1
15	Digital input 2	35	Ready relay output, N.O.
16	Digital input 1 Used as other inputs and as HSI = High Speed Input	36	Ready relay output, N.O.

Table 33. I/O Connection (X7A and X7B) at DMC².

X7A/B

I/O CONNECTION EXAMPLES

NPN TRANSDUCER, OPEN COLLECTOR TYPE

Recommended min. conductor area: 0,5 mm² (AWG20).

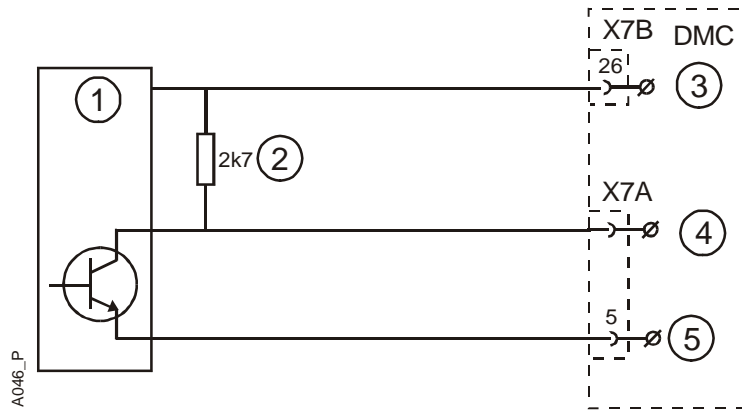

Figure 22. NPN open collector transistor interface to Digital input.

- | | | |
|--------------------|----------------------|------------|
| 1. NPN Transducer. | 2. Pull up resistor. | 3. 24V DC. |
| 4. Digital input. | 5. GND. | |

PNP TRANSDUCER

Recommended min. conductor area: 0,5 mm² (AWG20).

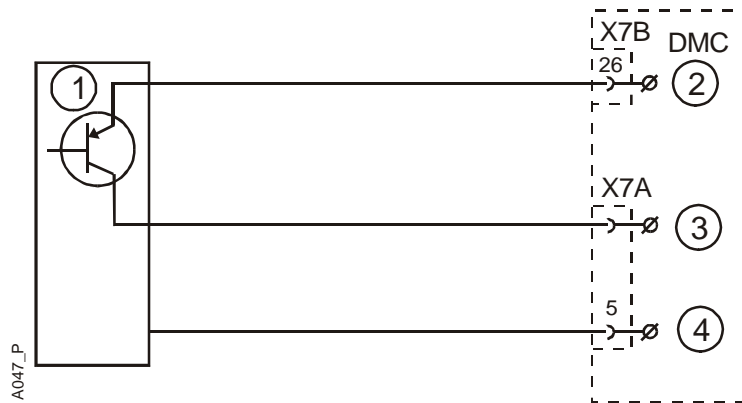

Figure 23. PNP transistor interface to digital input.

- | | | |
|--------------------|------------|-------------------|
| 1. PNP Transducer. | 2. 24V DC. | 3. Digital Input. |
| 4. GND. | | |

HIGH SPEED INPUT (DIGITAL INPUT1)

High speed: <1 micro second pulse.

Use shielded twisted pair cable.

Recommended min. conductor area: 0,5 mm² (AWG20).

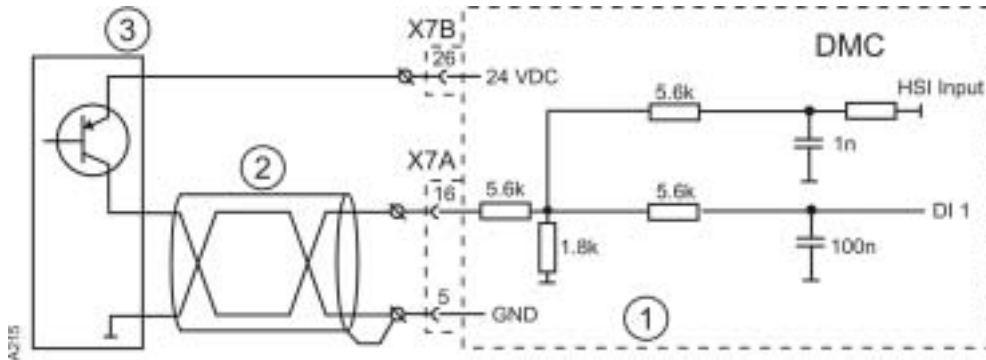

Figure 24. High speed input interface to digital input 1.

- 1. Digital input.
- 2. Shield.
- 3. Puls generator.

UNIPOLAR ANALOG INPUT

Recommended min. conductor area: 0,5 mm² (AWG20).

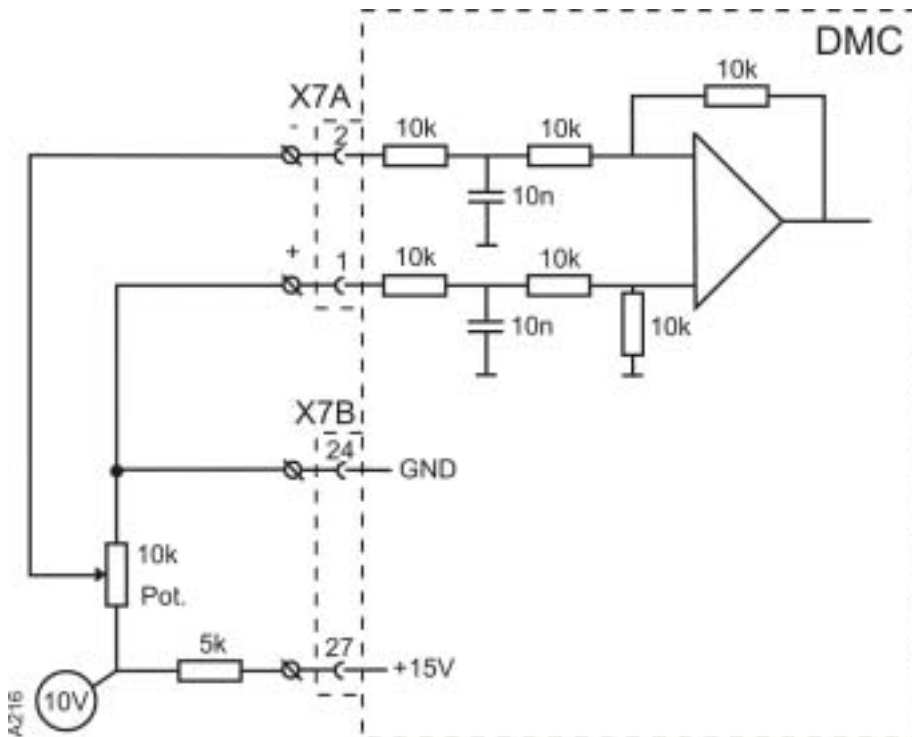

Figure 25. Unipolar analog input.

X7A/B

BIPOLAR ANALOG INPUT

Recommended min. conductor area: 0,5 mm² (AWG20).

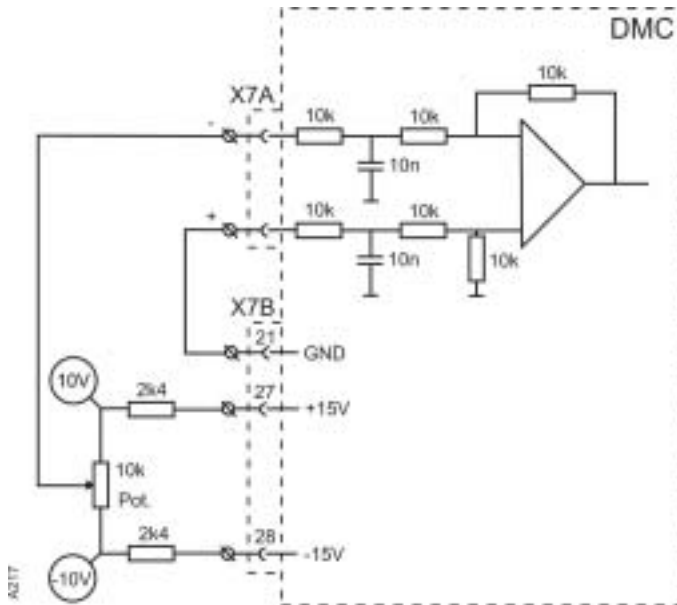

Figure 26. Bipolar analog input.

STANDARD DMC² OUTPUT

Recommended min. conductor area: 0,5 mm² (AWG20).

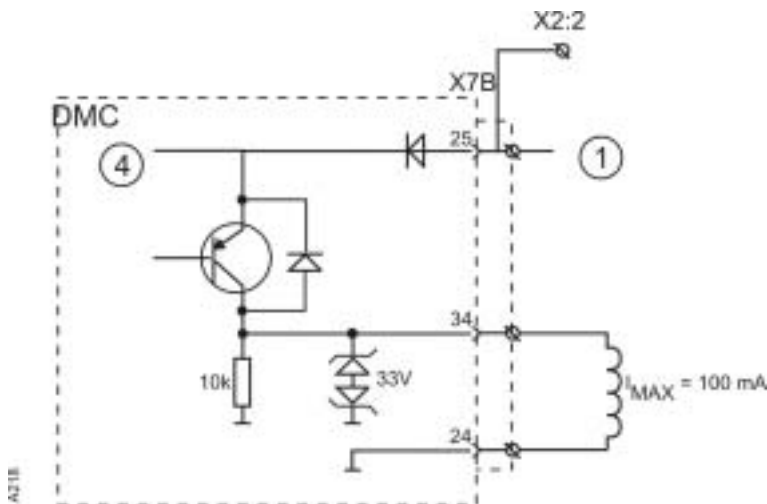

Figure 27. Standard DMC digital output.

1. User supplied power 24VDC for higher current output.
2. Output current $I_{MAX} = 100\text{mA}$.
3. To other outputs.
4. Internal +24 VDC.

ANALOG OUTPUTS

Recommended min. conductor area: 0,5 mm² (AWG20).

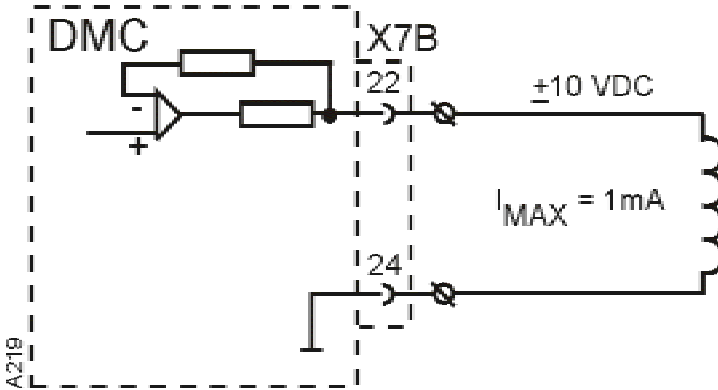

Figure 28. Analog output.

X8A

DMC ² P-CAN	50412	50720	51540	
DMC ² -CAN	50412	50720	51540	53080
Connector	See page 46			

For location, see [Figure 17](#).

DMC ² X8A	Function	Comment
1	GND	
2	NC	
3	NC	
4	Measure bridge Input +	Measure bridge input ±50mV
5	Measure bridge Input -	Measure bridge input ±50mV
6	GND	
7	-5V Supply Output	Supply to measure bridge. Max 10mA.
8	NC	
9	+5V Supply Output	Supply to measure bridge. Max 10mA.

Table 34. Measure Connection (X8).

X9A

X9A

DMC ² P	50412	50720	51540	
DMC ²	50412	50720	51540	53080
Connector	See page	46		

The CAN Bus is used for an external network. For location, see [Figure 17](#)

DMC ² X9A	Function	Comment
1	NC	
2	CiA CAN_L	
3	CiA GND	
4	NC	
5	NC	Shield
6	GND	Ground
7	CiA CAN_H	
8	NC	
9	CiA V+ 7-26.5 V	Supply

Table 35. LAN2 (X9) Connection.

X10

DMC ² P	50412	50720
DMC ²	50412	50720
Connector	See page	35

[Table 36](#) illustrates the input power connections to a DC supplied unit from an AC (P version) supplied unit. Connect the DC bus voltage from X10 to X10. [Figure 30](#) shows this application.

DMC ² P X10	Function	DMC ² X10
1	PE	1
2	+ DC bus voltage 570 VDC	2
3	- DC bus voltage 570 VDC	3

Table 36. DC Bus Connection.

X11

DMC ² P	50412	50720
DMC ²	50412	50720
Connector	See page	35

Figure 18 shows the connector X11. Table 37. describes the function. The motor connections are the same for AC and DC supplied DMC²s.

Use the appropriate threaded strain relief with shield connection listed in Table 9 to secure the motor cable to the junction box at the motor:

The cable shield must make secure metallic contact with the strain relief.

DMC ² X11	Function
1	Shield
2	PE
3	Motor U
4	Motor V
5	Motor W

Table 37. Motor Connection (X11) to DMC².

X13

DMC ² P	50412	50720
DMC ²	50412	50720
Connector	See page	35

Make the following dynamic brake circuit connections (Table 38), from X13 Figure 18 on DMC² unit to X34 on PS unit. Figure 20

DMC ² X13	Function	PS unit X34
1.	Output dynamic brake regulator, driver.	1
2.	Output dynamic brake regulator, -DC.	2
3.	NC.	3

Table 38. Dynamic brake (X13 and X34) Connection.

X14

DMC ² P	50412	50720
DMC ²	50412	50720
Connector	See page	35

Make the following connections (Table 39) at the DMC²:X14, (Figure 18 for placement) and the terminal block at the motor for thermistor and brake connections. See motor documentation for correct wiring.

X20

DMC ² X14	Function
1	Motor brake, Contact NO.
2	Motor brake, Contact NO.
3	NC, used as connection point
4	Thermistor out +15 VDC
5	Thermistor return

Table 39. Thermisto/brake (X14) Connection to DMC².

X20

DMC ² P		51540	
DMC ²		51540	53080
Connector	See page	35	

Table 40. illustrates the input power connections to a DC supplied unit from an AC (P version) supplied unit. Connect the DC bus voltage from X20 (P) (Figure 19 for placement) to X20. Figure 32 show how X20 is connected.

DMC ² P X20	Function	DMC ² X20	DMC ² X20
1	PE	1	1
2	PE	2	2
3	+ DC bus voltage 570 VDC	3	
4	+ DC bus voltage 570 VDC		4
5	- DC bus voltage 570 VDC	5	
6	- DC bus voltage 570 VDC		6

Table 40. DC Bus Connection (X20) between AC and DC.

X21

DMC ² P		51540	
DMC ²		51540	53080
Connector	See page	35	

Figure 19. shows the connector X21. Table 41 describes the function The motor connections are the same for AC and DC supplied DMC²s.

Use the appropriate threaded strain relief with shield connection listed in Table 9 to secure the motor cable to the motor.

The cable shield must make secure metallic contact with the strain relief.

DMC ² X21	Function
1	Shield
2	PE
3	PE
4	Motor U
5	Motor U
6	Motor V
7	Motor V
8	Motor W
9	Motor W

Table 41. Motor Connection (X21) to DMC².

X22

DMC ² P		51540	
DMC ²		51540	53080
Connector	See page	35	

Make the following dynamic brake circuit connections (Table 42) from X22 Figure 19 on DMC² unit to X34 on PS unit

DMC ² X22	Function	PS unit X34
1	Output dynamic brake regulator, driver	1
2	Output dynamic brake regulator, -DC	2
3	Reserved	3

Table 42. Dynamic brake (X22 and X34) Connection.

X23

DMC ² P		51540	
DMC ²		51540	53080
Connector	See page	35	

Make the following connections (Table 43) at the DMC², (Figure 19 for placement) X23 and the terminal block at the motor for thermistor and brake connections.

DMC ² X23	Function
1	Motor brake, Contact NO
2	Motor brake, Contact NO
3	NC, used as connection point
4	Thermistor out +15 VDC
5	Thermistor return

Table 43. Thermistor/brake (X23) Connection to DMC².

X31

X31

PS	580160
Connector	See page 35

At the power supply, make the following connections to X31 (see [Figure 20](#) and [Figure 31](#)) Note that the model PS580160 power supply is for 400 VAC, 3 phase applications. Use a WAGO 284 (10 mm²) Terminal block for interfacing to X31.

PS X31	Function
1	Phase L1, 400 VAC
2	Phase L2, 400 VAC
3	Phase L3, 400 VAC
4	PE
5	Dynamic brake resistor
6	Dynamic brake resistor

Table 44. Input Power at PS (X31).

X32 & X33

PS	580160
Connector	See page 35

DMC² 50412 OR DMC² 50720 DC BUS CONNECTION

The following information is applicable to DC supplied DMC²s ONLY.
Make the connections listed in [Table 45](#) below from X32 or X33 ([Figure 20](#)) on the stand-alone PS unit to X10 on the DMC² unit (see [Figure 18](#).) Note that X32 and X33 have a maximum current rating of 20 amps per pin.

PS unit X32 / X33	Function	DMC ² X10	DMC ² X10
1	PE	1	
2	PE		1
3	+ DC bus voltage	2	
4	+ DC bus voltage		2
5	- DC bus voltage	3	
6	- DC bus voltage		3

Table 45. DC Bus Connection from PS to DMC² 50412 and DMC² 50720.

DMC² 51540 OR DMC² 53080 DC BUS CONNECTION

Make the connections listed in [Table 46](#) below from X32 or X33 ([Figure 20](#)) on the stand-alone PS unit to X20 on the DMC² unit (see [Figure 19](#)).

Note that X32 and X33 have a maximum current rating of 20 amps per pin.

PS unit X32	Function	DMC ² X20	
(1.)	PE	1	
(2.)	PE	2	
3.	+ DC bus voltage	3	
4.	+ DC bus voltage	4	
5.	- DC bus voltage	5	
6.	- DC bus voltage	6	
PS unit X33	Function		DMC ² X20
(1.)	PE		1
(2.)	PE		2
3.	+ DC bus voltage		3
4.	+ DC bus voltage		4
5.	- DC bus voltage		5
6.	- DC bus voltage		6

Table 46. DC Bus Connection from PS to DMC² 51540 and DMC² 53080.

X34

PS 580160

Connector See page [35](#)

Make the following dynamic brake circuit connections from X34 ([Figure 20](#)) on PS unit to X13 ([Figure 18](#)) or X22 ([Figure 19](#)) on DMC² unit.

PS unit X34	Function	DMC ² X13	DMC ² X22
1.	Output dynamic brake regulator, driver.	1	1
2.	Output dynamic brake regulator, -DC.	2	2
3.	Reserved.	3	3

Table 47. Dynamic brake connection (X34).

X35

PS 580160

Connector See page

Make the following thermistor connections from X35 ([Figure 20](#)) on PS unit to X14 ([Figure 18](#)) or X23 ([Figure 19](#)) on DMC² unit.

Input wiring diagram

PS unit X35	Function	DMC ² X14	DMC ² X23
1.	Temperature switch out +15 VDC.	4	4
2.	Temperature switch return.	5	5
	NC, used as connection point.	3	3

Table 48. Thermistor connection (X35).

INPUT WIRING DIAGRAM

SINGLE INSTALLATION

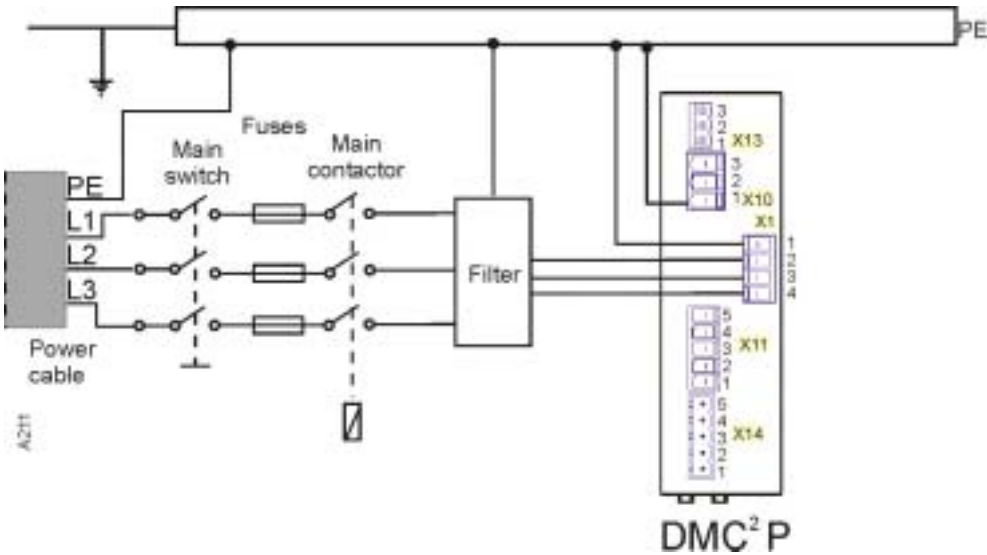

Figure 29. Input power connection to a single application.

DMC²-P/DMC² INSTALLATION

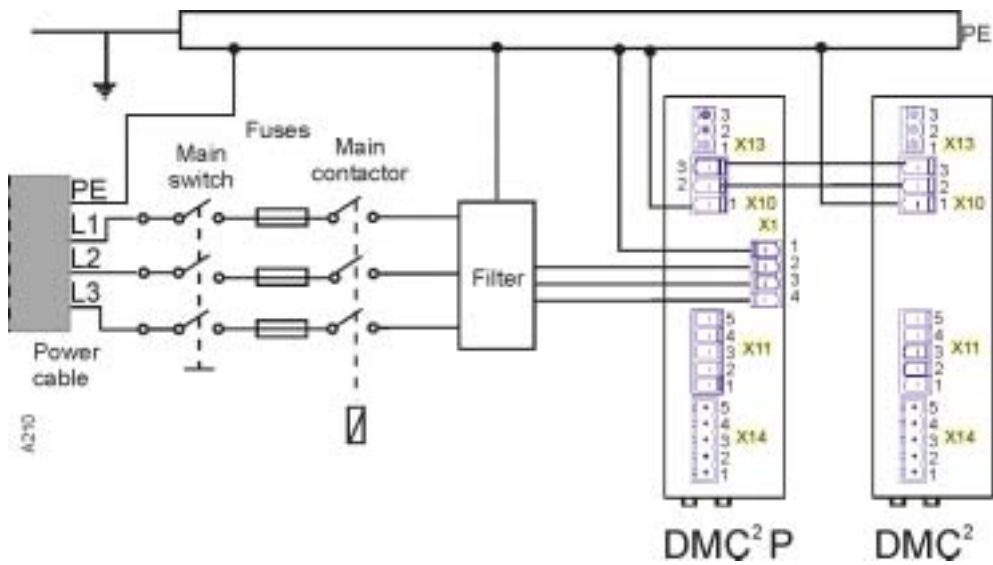

Figure 30. Input power connection to a Master/Follower application.

Input wiring diagram

POWER SUPPLY/DMC² 50412, 50720 INSTALLATION

Figure 31. Input power connection to a Power Supply application.

POWER SUPPLY/DMC² 51540, 53080 INSTALLATION

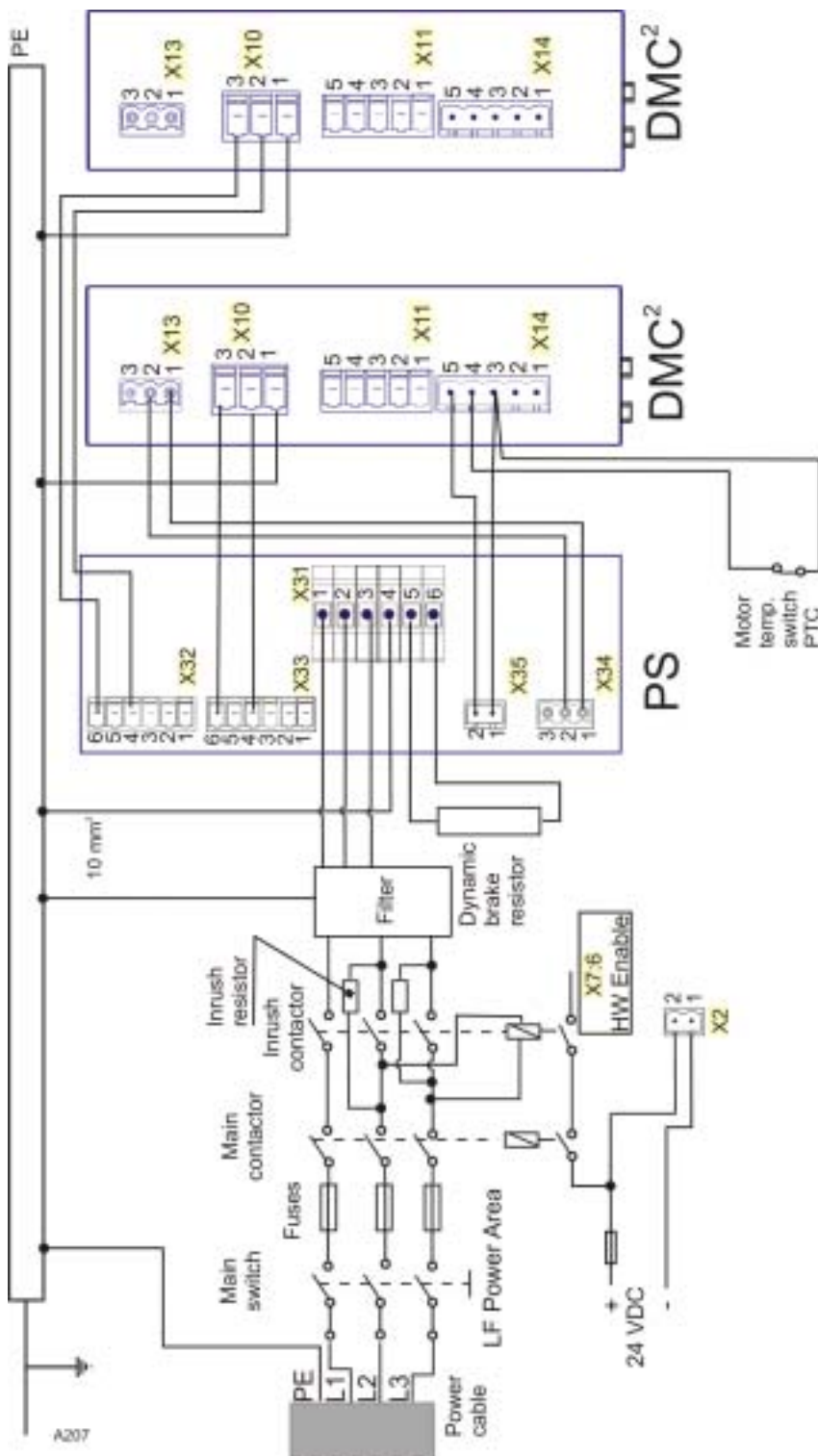
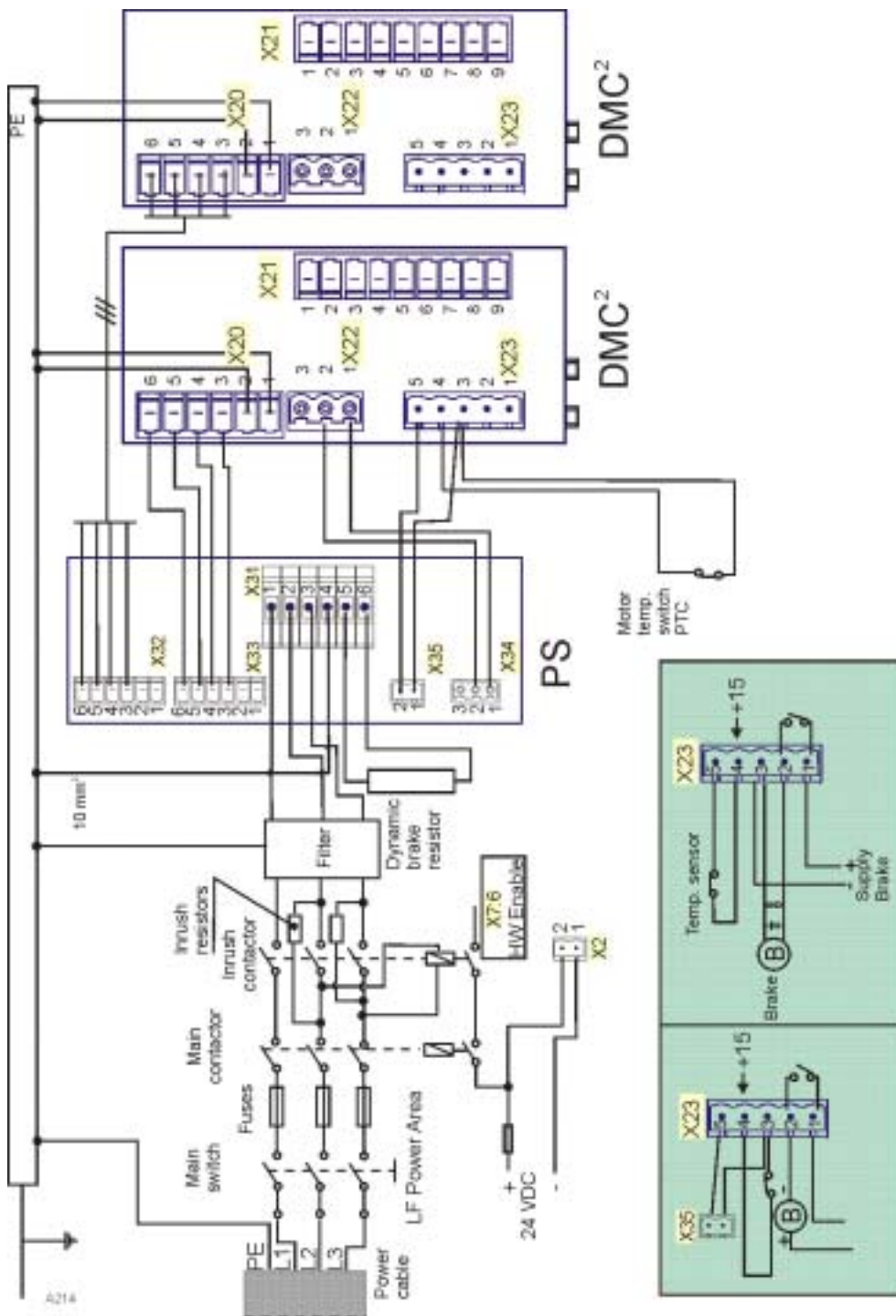

Figure 32. Input power connection to a Power Supply application.

Installing the DMC² in a cabinet

GENERAL

During mounting and installation of a DMC² unit in a cabinet beware of the following:

- Sufficient protective earth grounding.
- Thermal dimensioning of the cabinet and cooling of the DMC² unit.
- Placement of the DMC² unit in relation with other components in the cabinet.
- Installation performed in accordance with applicable regulations.

SEPARATION OF CONTROL AND POWER AREAS

The cabinet should be separated into different zones with high power/high voltage components separated from low power/low voltage components where possible. [Figure 33](#) shows an example of a typical installation in a cabinet. Note the separation of the input power section with dangerous voltages on the right and the terminal PC on the left. The DMC² units have been mounted in the upper half of the cabinet. This placement is suitable from several points of view. It prevents heat from the DMC² from heating other components in the cabinet. This arrangement also permits motor, power and ground cabling to be separated from other low level signal cabling (see [Figure 34](#). and [Figure 35](#).). [Figure 36](#). illustrates the recommended general cabinet arrangement in which four different zones are created:

- HF Control area
- HF Power area
- LF Control area
- LF Power area

Between cables and components in the HF and LF zones there should be at least a 200-mm. separation. Cables from LF zones, which pass through the HF zones, shall be shielded. Cables and components in power areas shall be separated from components in control areas.

Installation example

INSTALLATION EXAMPLE

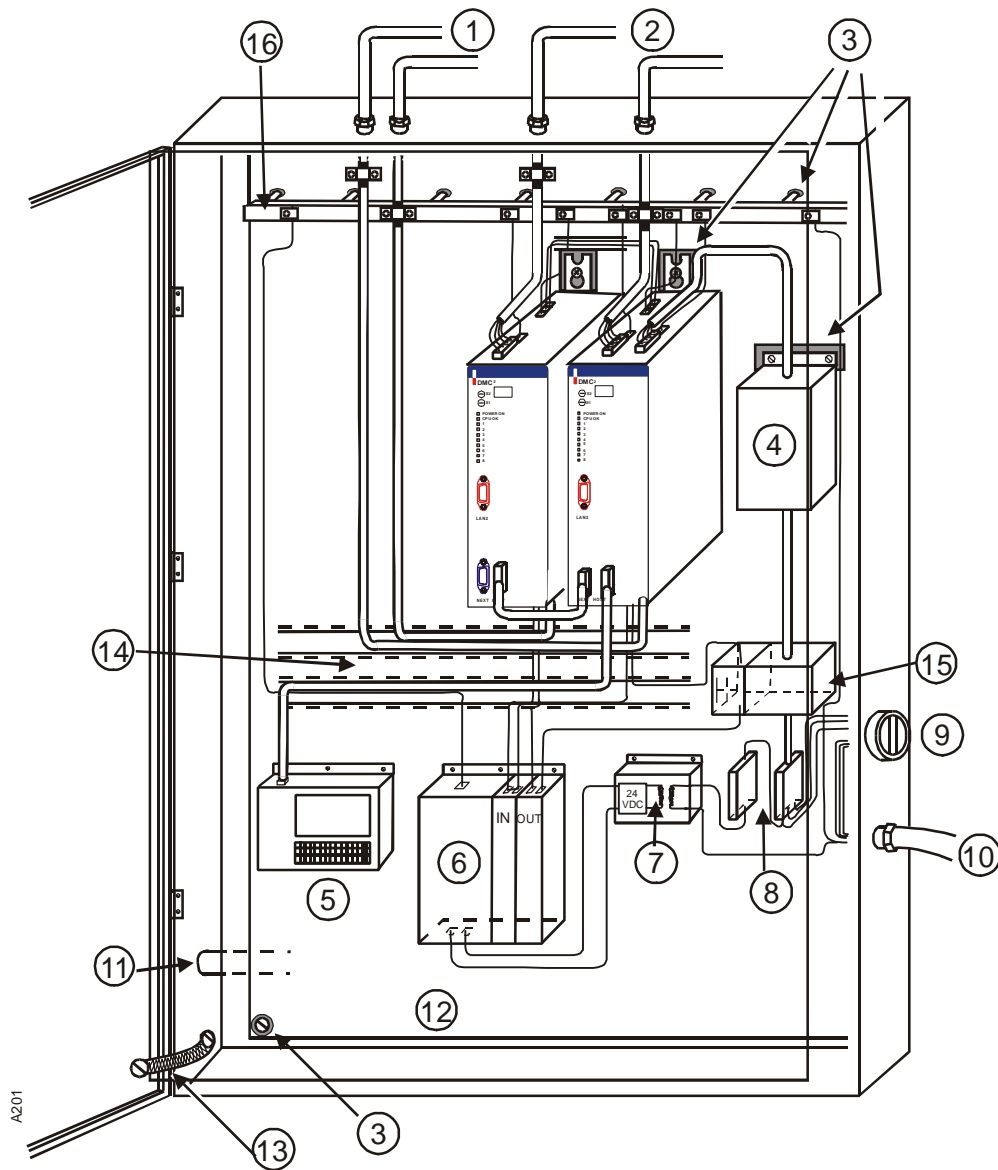

Figure 33. Example of installation in a cabinet.

- | | | |
|----------------------------|------------------------|----------------------------|
| 1. To resolver. | 2. To motor. | 3. Good electrical contact |
| 4. Filter. | 5. Terminale PC. | 6. PLC. |
| 7. Transformer. | 8. Fuses. | 9. Main switch. |
| 10. Power cable. | 11. I/O communication. | 12. Mounting plate. |
| 13. Earth wire. | 14. Cable channel. | 15. Contactor. |
| 16. Protective earth rail. | | |

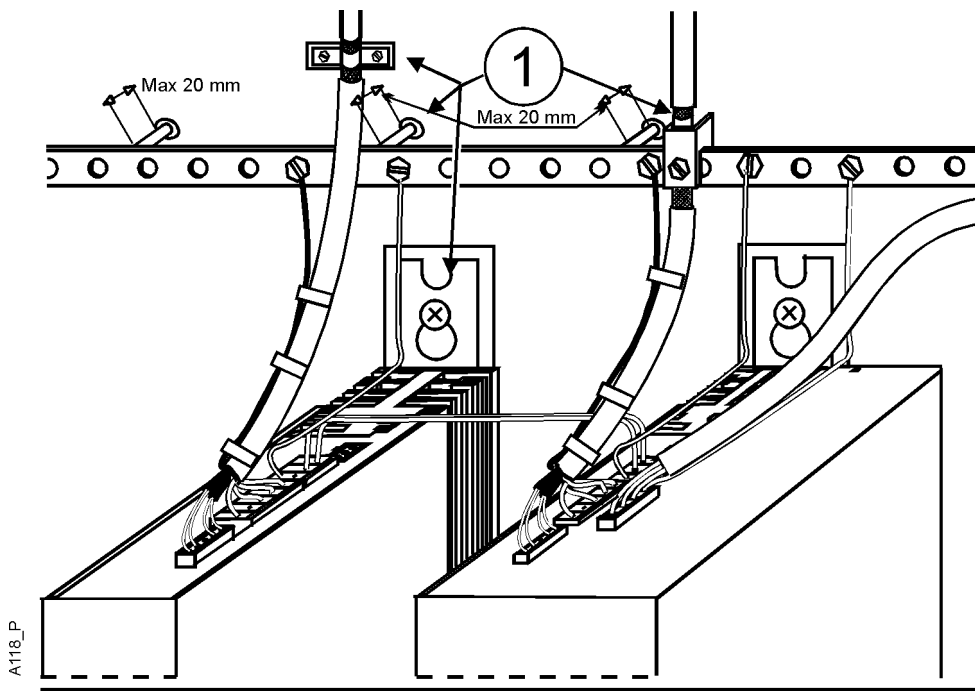

Figure 34. Motor, power and ground connections.

1. Good electrical contact here.

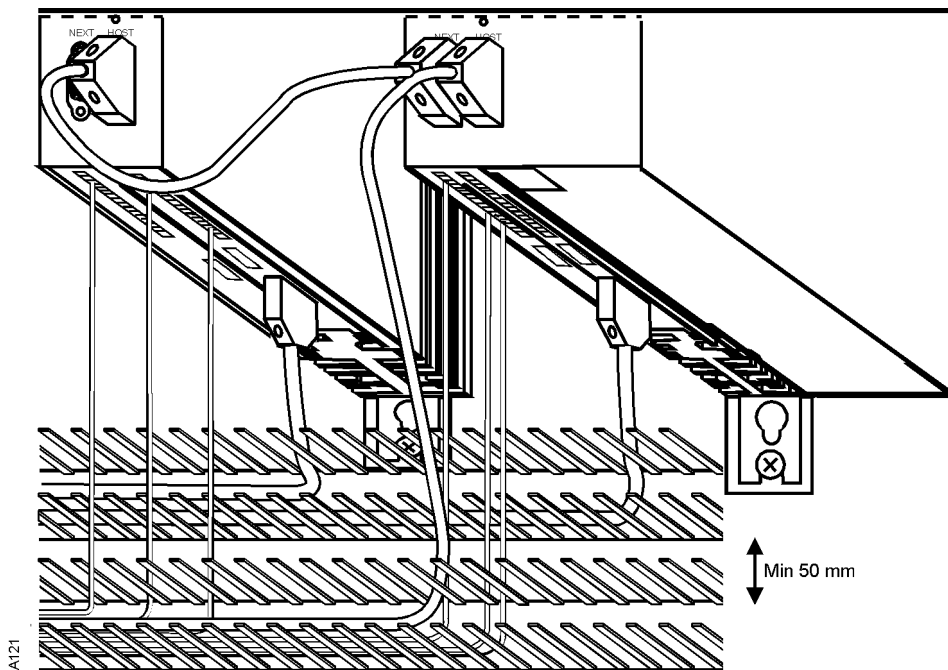

Figure 35. I/O resolver and communications connections.

Cabinet Space Requirements

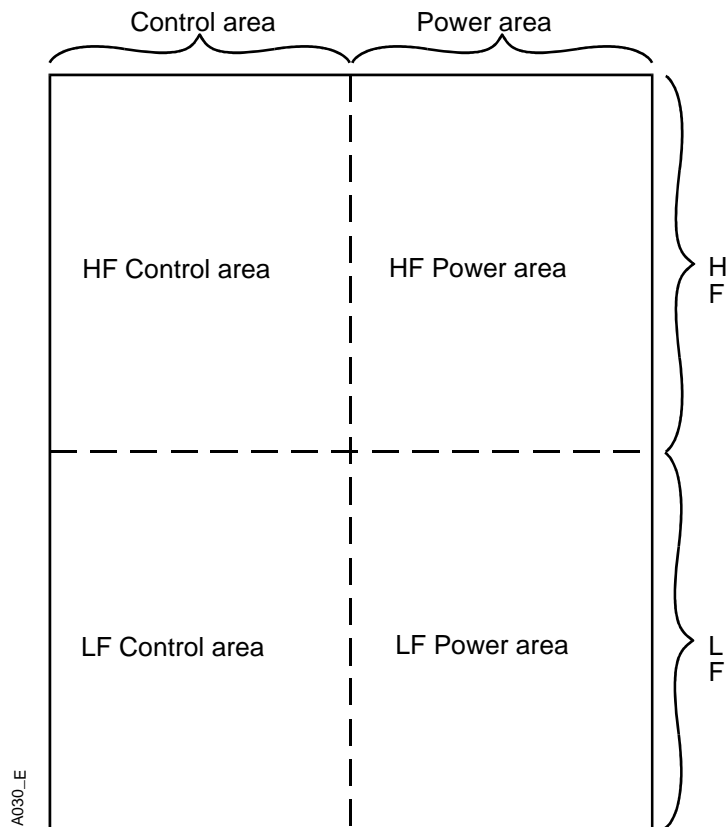

Figure 36. General cabinet layout recommendation.

CABINET SPACE REQUIREMENTS

MOUNTING DIMENSIONS AND CLEARANCES

Figure 37. shows recommended minimum clearances for air flow, cable bends, etc. when mounting the DMC² unit. Mounting dimensions for various DMC² models are shown in Figure 38.

Cabinet Space Requirements

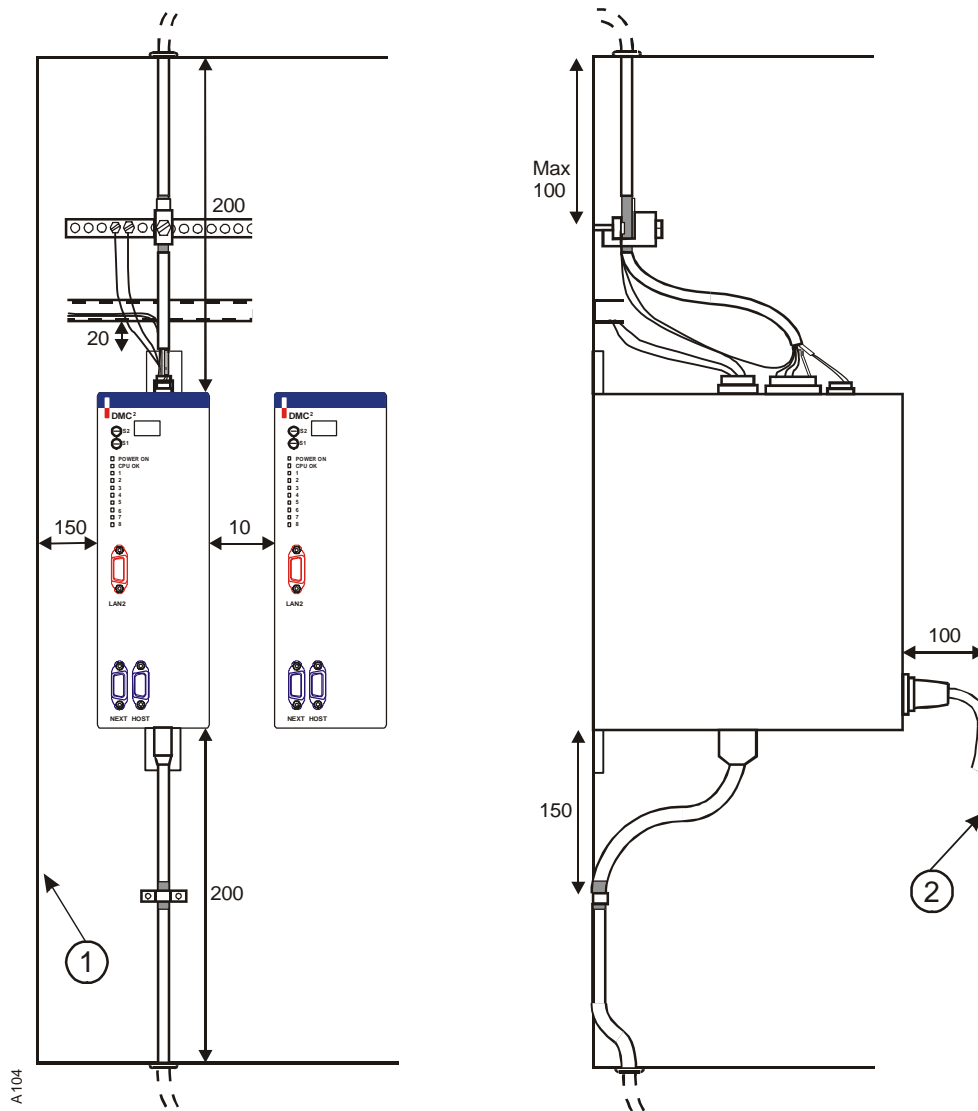

Figure 37. Minimum clearances when mounting DMC².

1. Cabinet wall.
2. Cabinet door.

Cabinet Space Requirements

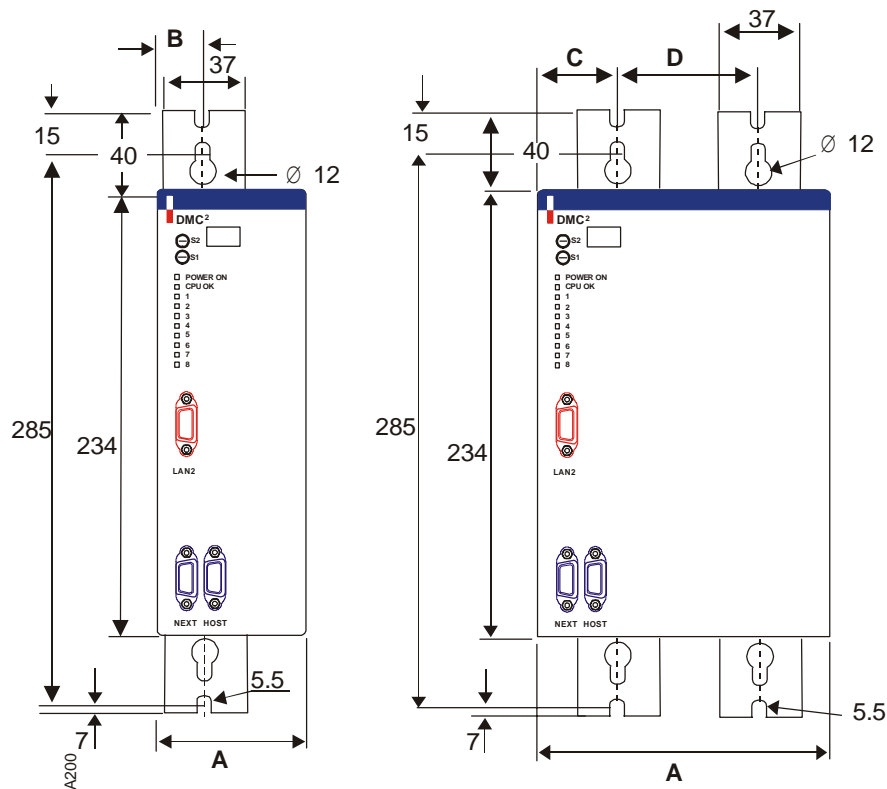

Figure 38. DMC² mounting dimensions (in mm). Depth for all units is 223 mm.

	50412 50720	50412P 50720P	51540	51540P	53080 PS580160
A	46	76	122	160	173
B	23.5	23.5	59		
C				22	59
D				75.5	91.5

ELECTROMAGNETIC COMPATIBILITY CONSIDERATIONS

The DMC² and other PDS components must be installed and operated in accordance with the instructions in this manual, to fulfill the EMC (Electromagnetic Compatibility) requirements.

SCREENING

The purpose of screening (shielding) is to prevent unwanted electromagnetic radiation from entering or escaping the system. This means that screening applies to cabinets as well as cables. The motor cable, resolver cable and the serial communication cable must be screened. The screens shall be connected to both ends of the cable with metallic connector housings (see Figure 39.). The junction box on the motor (see Figure 41.) must be metallic, not plastic.

STRAIN RELIEF

A complete cable installation, (Motor cable and Resolver cable [Figure 41](#)), require a strain relief to fulfil EMC regulations.

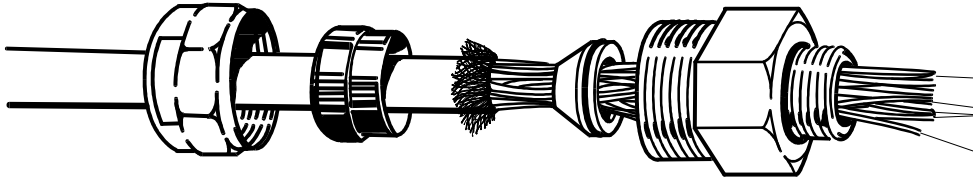

Figure 39. Screening of the cable.

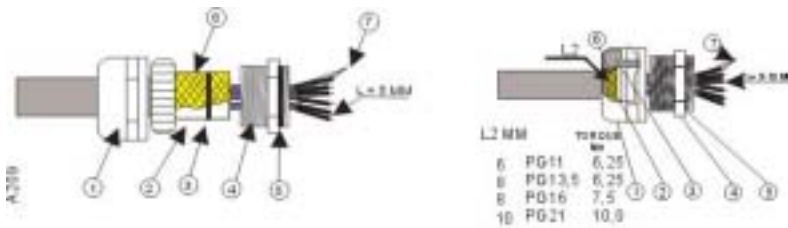

Figure 40. Hummel and Pflüch strain relief.

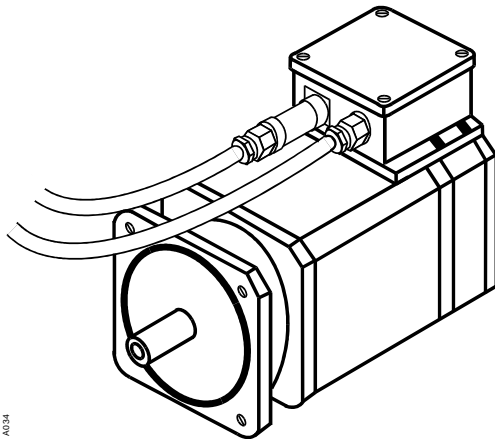

Figure 41. Motor and resolver cable connections at metallic junction box on motor.

GROUNDING FOR HIGH FREQUENCIES

The inner areas of the cabinet and the mounting plate shall be galvanized and without paint. If paint is used, it must be removed at the component mounting surfaces for good high frequency grounding.

Thermal Considerations

The cables shall be mounted along metallic surfaces. If possible, mount the cabinet and the machine with clean (no paint) surfaces against each other. (See [Figure 42.](#))

All cables entering the cabinet shall be high frequency earth grounded at the point where the cable enters the cabinet.

There must be good electrical contact between the DMC² unit and the shield of the motor cable. If the motor cable shield is connected to the protective earth rail, the protective earth rail shall be high frequency grounded to the mounting plate at several places. (See [Figure 34.](#))

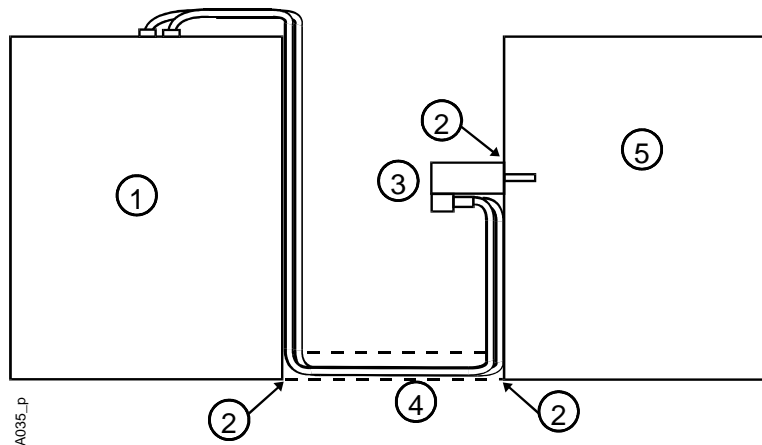

Figure 42. Example of high frequency grounding techniques.

- | | | |
|--|--------------------------|-----------------|
| 1. Cabinet with DMC ² unit. | 2. Metal clean surface. | 3. Servo motor. |
| 4. Metal cable rail. | 5. Machine to be driven. | |

PROTECTIVE EARTH GROUNDING

Do not daisy chain earth ground connections. Run a separate wire between each component to be grounded and the ground point.

The ground wire (protective earth ground) in the motor cable shall not be connected to the DMC². Connect it directly to the protective earth rail ([Figure 34.](#))

The earth ground for each DMC² shall utilize two conductors, each having the same wire gauge as the input power cable.

THERMAL CONSIDERATIONS

When DMC² units are mounted side by side (see [Figure 37.](#)), the cooling effect is decreased approximately 30 %. Using the cooling effect from the mounting plate on which the DMC² units are mounted can compensate this. The necessary area for compensation is 0,04 m²/DMC².

At temperatures above 40°C, a fan is recommended because of the decrease of current rating above this temperature. The use of a fan will also compensate for the increased ambient temperature and thus avoid the reduced lifetime of the electronics. The fan can be mounted either on the DMC² unit or beside it.

Technical Specifications

570 V DC BUS MODEL

Model	DMC ² 50412	DMC ² 50720	DMC ² 51540	DMC ² 53080
Peak current (A)	12	20	40	80
Cont. current (A) at 40° C	4	7	15	30
Cont. current, RMS (A) at 40°C	2.2	4.5	10.5	21
Cont. power (kW) at 40°C	1.4	3	6.3	13.8
Min motor inductance (phase-phase) (mH)	10	8	6	3
Efficiency at cont. current	95 %			
Speed linearity	< 1%			
Torque linearity	±1 % of full scale plus ±2% command value			
Current open loop bandwidth	2 kHz			
Speed loop bandwidth	Depending on motor and load			
Input voltage	570 VDC + 10% : -20%			
DC bus voltage	570 VDC + 10% : -20%			
Shunt regulation On	670 - 700 VDC			
Shut down DC bus voltage	700 - 725 VDC			
Speed range	1:9000			
Switching frequency	4kHz			
Ambient temperature	0°C to 60°C			
Storage temperature	-20°C to 80°C			
Humidity	95 %			
Height (mm)	234			
Depth (mm)	227			
Width (mm)	46	46	122	173
Weight (kg)	2.7	2.7	5.1	6.9
Protection	IP 20			

400 V AC Bus models

400 V AC BUS MODELS

Model	DMC ² 50412P	DMC ² 50720P	DMC ² 51540P
Peak current (A).	12	20	40
Cont. current (A) at 40°C.	4	7	15
Cont current, RMS (A) at 40°C.	2.2	4.5	10.5
Cont. power (kW) at 40°C.	1.9	3.4	7.4
Min motor ind. (phase-phase) (mH).	10	8	6
Efficiency at cont. current.	95 %		
Speed linearity.	< 1 %		
Torque linearity.	±1 % of full scale plus ±2% of command value		
Current open loop bandwidth.	2kHz		
Speed loop bandwidth.	Depending on motor and load.		
Input voltage.	3 phase 400 VAC + 10% : -20%		
DC bus voltage.	570 VDC + 10% : -20%		
Shunt regulation On.	675 - 700 VDC		
Shut down DC bus voltage.	700 - 725 VDC		
Speed range.	1:9000		
Switching frequency.	4 kHz		
Ambient temperature.	0°C to 60°C		
Storage temperature.	-20°C to 80°C		
Humidity.	95 %		
Height (mm).	234		
Depth (mm).	227		
Width (mm).	76	76	160
Weight (kg).	3.8	3.8	6.8
Protection.	IP 20		

STAND ALONE POWER SUPPLY

Model	PS 580160
Peak current (A).	160
Input Cont current, RMS (A) at 40°C.	65
Cont. power (kW) at 40°C.	45.5
Efficiency at cont. current.	
Input voltage.	3 phase 400 VAC -20% - +10%
DC bus Cont. current CC (A) at 40°C.	80
DC bus voltage.	570VDC,+10%:-20%
Ambient temperature.	0°C to 60°C
Storage temperature.	-20°C to 80°C
Humidity.	95%
Height (mm).	234
Depth (mm).	227
Width (mm).	173
Weight (kg).	7.2
Protection.	IP 20
Dynamic brake peak current (A).	70
Dynamic brake cont. current (A).	35
Dynamic brake max. energy on pulse.	Depends on rating for the external dynamic brake resistor.
Dynamic brake cont. power.	Depends on rating for the external dynamic brake resistor.

I/O

Digital inputs:	
Number of inputs	10
Maximum voltage	30 V
Input high	> 12.9 V, typical 10 V
Input low	<2 V, typical 5 V
Hysteresis	>3 V, typical 5 V
Input impedance to ground	6.8 kΩ
Filter time	0.7 ms

External Logic Supply

Digital outputs:	
Number of outputs	6
Output high	+24 V
Output low	< 0.7 V
Max voltage	+ 30 V DC
Max current	100 mA, short circuits proof.
Max voltage drop	3 V
Analog inputs:	
Number of inputs	2
Voltage range	±10 V
Common mode voltage	±10 V, Max.
Resolution	14 bit
Linearity	8 bit
Input impedance	40 kΩ
Filter time	0.1 ms
Analog outputs:	
Number of outputs	2
Resolution	12 bit
Voltage swing	±10 V
Max current	0.5 mA
Dedicated output for READY signal:	
Controlled by	Software and hardware
Type	Relay, normally open
Max voltage	24V DC
Max current	0.2A
Motor brake relay output:	
Rating AC	250 VAC / 2 A
Rating DC	24 VDC / 2A
External freewheeling diode required	

EXTERNAL LOGIC SUPPLY

Type	Specification
Voltage	+24 V ±20%
Max Supply Current	0.7 A
External fuse	1.5 A T (Slow)

OPTIONAL POSITION SENSORS

Encoder	Function	Specification	Remark
Incremental Encoder	External movement sensor.	5 V / RS422	Only one could be used at same time.
SinCos Encoder	Motor shaft or external movement sensor	1Vpp EnDat	

MEASURE CONNECTION

Function	Specification
Low-level differential analog input for measurement bridge.	Input $\pm 50\text{mV}$ $\pm 5\text{ V DC}$ supply available.

LAN2

Function	Specification
Second LAN interface in accordance with CANopen standard CiA 301.	Isolated 7-26.5 VDC external supply.

ENVIRONMENTAL DATA

Environment	Specification
Pollution degree (IEC 664,A)	Degree 2
Altitude	1000 m
Protection class	IP 20, Nema 1
EMC, Emission	EN 50081-2
EMC, Immunity	EN 50082-2

ENVIRONMENTAL TESTS

Operating on average load:	
Cold (IEC 68-2-1)	$\pm 0^{\circ}\text{C}$, 2 h
Heat (IEC 68-2-2)	$+40^{\circ}\text{C}$, 2 h
Operating on reduced load:	
Cold (IEC 68-2-1)	$\pm 0^{\circ}\text{C}$, 2 h
Heat (IEC 68-2-2)	$+60^{\circ}\text{C}$, 2 h

Resolver Specification

Power turned off, storage:	
Cold (IEC 68-2-1)	-40°C, 16 h
Heat (IEC 68-2-2)	+85°C, 16 h
Change (IEC 68-2-14)	-40°C to 85°C, 2 cycle
Humidity (IEC 68-2-30)	95%, +25°C - +40°C, 6 cycle
Bumps (IEC 68-2-29)	100 m/s ² s, 4 - 7 ms, 3x1000 cycle
Vibration (IEC 68-2-6)	10-55 Hz, ±0.15mm 55-150 Hz, 20 m/s ² s

RESOLVER SPECIFICATION

Winding Configuration	1-phase input / 2 phase output
Primary	Rotor
Pole Number	2-pole or more
Operating Frequency	4 kHz
Output Voltage	3 V _{rms}
Input Voltage	3 - 8 V _{rms} (depends on Transformation Ratio)
Transformation Ratio	0.4-1.0 at 4kHz
Phase Shift	±45°
Input Current	Max 150 mA (preferable max 75 mA) ¹⁾
Electrical Error	<25 arc minute
¹⁾ DMC ² resolver output are able to drive 150 mA. If two resolvers are driven from one DMC ² , then each resolvers input current should be max 75 mA.	

Start up and Commissioning

	<p>WARNING</p> <ul style="list-style-type: none">◆ The DMC² contains voltages, which may be as high as 575 volts. These high voltages can cause serious or fatal injury. Only qualified personnel familiar with this manual, software control of the DMC² and machinery driven by this equipment should attempt to start up or troubleshoot this equipment.◆ DO NOT touch electrical components, power devices or connections without first insuring that high voltage is not present. Storage capacitors within the equipment require 20 seconds to discharge after AC power is removed.◆ Incorrect programs, faulty equipment or faulty or incorrect connections may cause sudden, violent motion of the motor shaft and driven equipment. Peak torque of several times rated motor torque can occur under these conditions. Be certain that unexpected motor shaft movement will not cause injury to personnel or damage to the driven equipment.◆ High voltages may be present at the motor whenever AC power is applied, even when the motor is not moving. Make certain that no motor connections are exposed.
---	--

CHECKS PRIOR TO INITIAL POWER UP

BEFORE POWER UP THE FIRSTS TIME

- Check the wiring of the DMC² installation.
- Check ground and shields connections of the installation.
- Check that the voltage for mains is correct.
- Make sure that there is a fast way to disconnect the main power to the DMC² with an emergency stop.
- The DMC² should have a BRAM or EPROM with application program that sets up motor parameters, regulator parameters, protection functions and the functionality of the application.
- Make sure that the enable signal to the DMC² is disabled until the installation have been completely power up and are ready to be used.
- Make sure that the motor shaft can run freely and that the temperature protection in the motor is connected to the DMC².

BEFORE ENABLE THE POWER STAGE AFTER POWER UP

- If BRAM are used, down load an application program that sets up motor parameters, regulator parameters, protection functions and the functionality of the application.
- Set current limit to a low value so that the motor could handle the current without getting overheated.

Check that the resolver feedback and I/O functions in the application programs are working correctly.

LOAD A NEW FIRMWARE RELEASE

The PL command 'BOOT' can be used to enter boot mode, when an existing copy of firmware already resides in the flash.

Load a new firmware release

1. Turn power to the drive off.
2. Short pin 2 and pin3 on connector X5 or X4 (serial communication).
(This will echo content sent by the drive back to the drive).
3. Apply power to the drive.
4. Remove short applied at step 2.
5. Without removing power to the drive connect to the ECT terminal emulator.
Warning: Make sure that both the DMC² and the PC are earth grounded failure to do so may result in damage the DMC² unit and/or the PC!
6. The BOOT monitor should have been entered.
First, the current program must be erased, to do that type,
>EA
or
>EF
EA - Erase all.
EF - Erase firmware (currently same as EA).
H - Help.
When command has finished then next step.
7. Select CONTROLLER:DOWNLOAD from the menu and select the new firmware file
(firmware extension is *.hex).
8. Wait for download to finish
9. The new firmware should now be stored into the flash unless reported
otherwise, turn the power off or type,
>RF
RF - Run firmware
10. Download the application program again.
Note. Any stored PL program will have been erased from the flash. In a future
release the EF command will erase only the firmware parts.

BOOT MODE COMMAND

With the addition of the 'boot' command a user can enter the boot mode from the terminal. This simplifies the above procedure to,

1. Turn power to the drive on
2. Type 'boot' when the '>' prompt is seen.
>boot<ENTER>
3. The unit has entered 'BOOT MODE'. Continue from step 6 in the above list.

STARTUP MESSAGE

When power is applied to the DMC² the following startup message is displayed,

```
ACC DMC/ Inmotion Technology AB v05.00.00 Node#: 1 Baud: 9600
Mode: 0
```

This line is always sent using 9600 baud independent of the settings in the eeprom related to the COMM group or any programming of the COMM group. The line gives information about the content of the EEPROM used for initialization of the serial communication (COMM group).

The assignments made to the COMM group by the firmware at startup, are:

Node	COMM.Node = EEPROM.6 and 15.
Baud	<pre> If EEPROM.4 = 0 then COMM.Baud = BaudTable[EEPROM.6 >> 8] else COMM.Baud = EEPROM.4 </pre>
Mode	<pre> COMM.Mode = EEPROM.7 and 15 COMM.TLines = EEPROM.7 >> 8 </pre> <p>BaudTable is a table of 8 baudrate values, 50..9600</p>

If there appears to be a problem communicating with the DMC², then check the startup message first to verify that the initial settings are correct.