

BA33.0001  
13055270

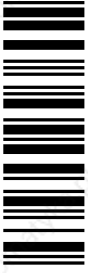

## Operating Instructions

# Global Drive

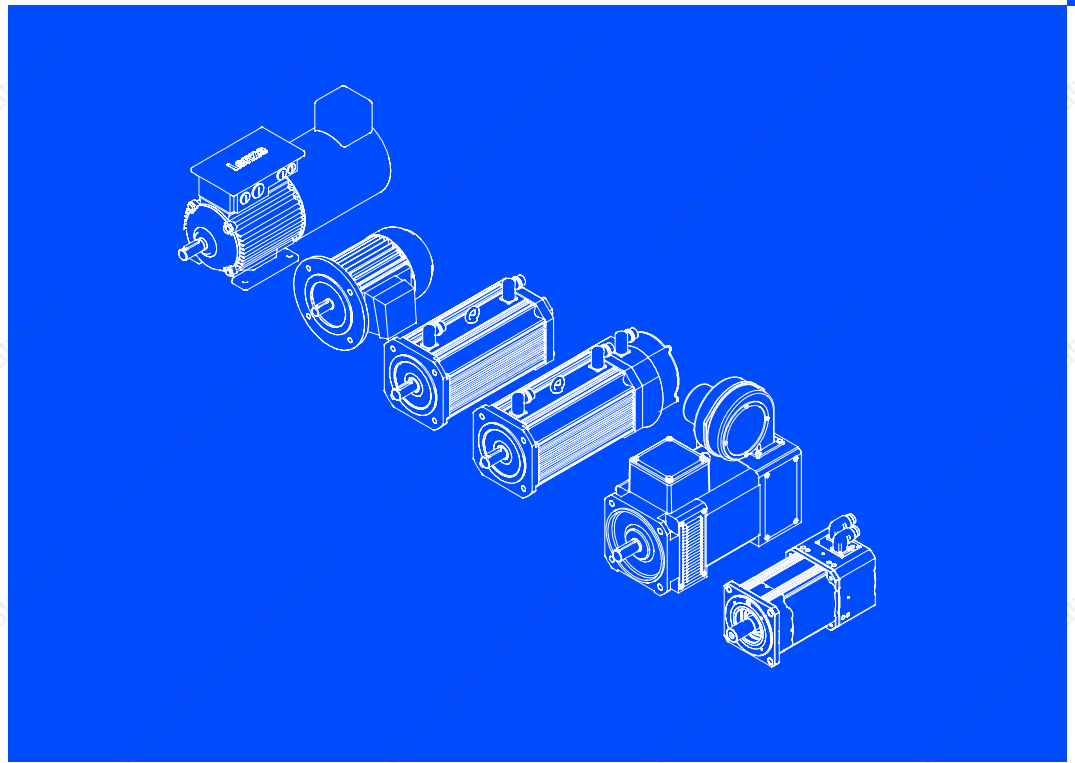

**Servo motors MDXK, MDFQA, MCS, MCA**  
**Three-phase AC motors MDXMA**

## Nameplates for MCS, MCA compact servo motors

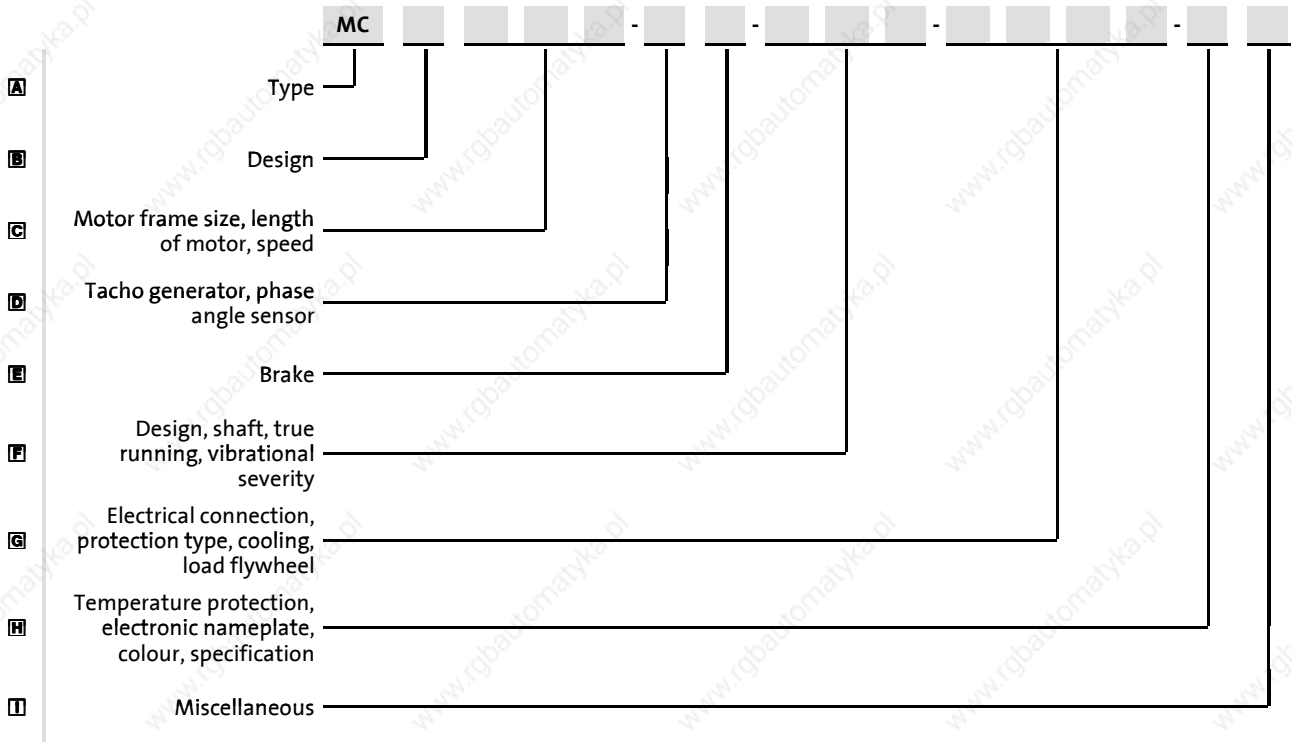

### Legend for nameplates of MCS, MCA compact servo motors

<b>A</b>	MC	Servo motor
<b>B</b>	A	Asynchronous
	S	Synchronous
<b>C</b>	06	Square dimension 62mm
	09	Square dimension 89mm
	10	Square dimension 102mm
	12	Square dimension 116mm
	13	Square dimension 130mm
	14	Square dimension 142mm
	17	Square dimension 165mm
	19	Square dimension 192mm
	21	Square dimension 214mm
	C ... X	Overall length
	XX	Speed in 100min <sup>-1</sup>
<b>D</b>	RS0	Resolver p=1
	SRS	Singleturn absolute value encoder with Sin-Cos signals, Hiperface
	SRM	Multiturn absolute value encoder with Sin-Cos signals, Hiperface
	ECN	Singleturn absolute value encoder with Sin-Cos signals, Endat
	EQN	Multiturn absolute value encoder with Sin-Cos signals, Endat
	EQI	Multiturn absolute value encoder with Sin-Cos signals, Endat
	CXX	Incremental encoder TTL with commutation signals UVW
	TXX	Incremental encoder TTL
	HXX	Incremental encoder HTL
	NNO	No encoder

### Legend for nameplates of MCS, MCA compact servo motors

<b>E</b>	B0	Without brake	P1	PM brake 24V-DC
	F1	Spring-operated brake 24V-DC	P2	PM-brake 24V-DC, reinforced
	F2	Spring-operated brake 24V-DC, reinforced	P5	PM brake 205V-DC
	F5	Spring-operated brake 205V-DC	P6	PM brake 205V-DC, reinforced
	F6	Spring-operated brake 205V-DC, reinforced		
<b>F</b>	A	Standard flange form A/FF with through hole, cyl. shaft without featherkey		
	B	Standard flange form A/FF with through hole, cyl. shaft with featherkey		
	C	Standard flange form C/FT with through hole, cyl. shaft without featherkey		
	N	Standard flange form C/FT with through hole, cyl. shaft with featherkey (standard add-on)		
	F	Identical to design A but with large flange		
	G	Identical to design B but with large flange		
	U	Identical to design C but with large flange		
	V	Identical to design N but with large flange		
	11	Shaft 11x23 (MCS06)	24	Shaft 24x50 (MCS14; MCA14, 17)
	14	Shaft 14x30 (MCS09; MCA 10)	28	Shaft 28x60 (MCS19; MCA19)
	19	Shaft 19x40 (MCS12; MCA13)	38	Shaft 38x80 (MCA21)
	N or R	True running/vibrational severity		
	Z0X	Direct gearbox attachment: motor without pinion for mounting on open gearbox with pinion; flange for direct gearbox attachment without intermediate cover, with tapered hollow shaft; tapered shaft MCS06 ... 19		
	Y0X	Direct gearbox attachment: motor without pinion for mounting on open gearbox with pinion; flange for direct gearbox attachment with intermediate cover, with tapered hollow shaft; tapered shaft MCA10 ... 21		
<b>G</b>	ST	Separate circular connector for power/brake, encoder/temperature, fan		
	SQ	Shared rectangular connector for power, encoder...		
	KK	Terminal box for power/brake, encoder/temperature, fan		
	KS	Terminal box for power/brake/fan and plug-in connection for encoder/temperature		
	5	IP54 without shaft sealing ring (except direct gearbox attachment)		
	6	IP65 with shaft sealing ring		
	A	IP64 (A flange, without shaft sealing ring) / IP65		
	B	IP54 with shaft sealing ring (A bearing oil-tight)		
	C	IP54 with shaft sealing ring double lip (A lag dustproof)		
	D	IP65 with shaft sealing ring, double lip		
	S00	Self-ventilation / without fan		
	I00	Internal cooling		
	F10	Separate fan 230V; AC; 1N		
	N	Without load flywheel		
J	With additional mass inertia			
<b>H</b>	0	Standard nameplate		
	2	Second nameplate provided unattached		
	S	Colour: black		
	0	Specification - Standard		
	R	Temperature protection KTY sensor		
	U	Specification - UL design, approval UR		
	E	Temperature protection KTY sensor; electronic nameplate		
<b>I</b>	Miscellaneous			

## Nameplates for MDXK servo motors and MDXMA three-phase AC motors

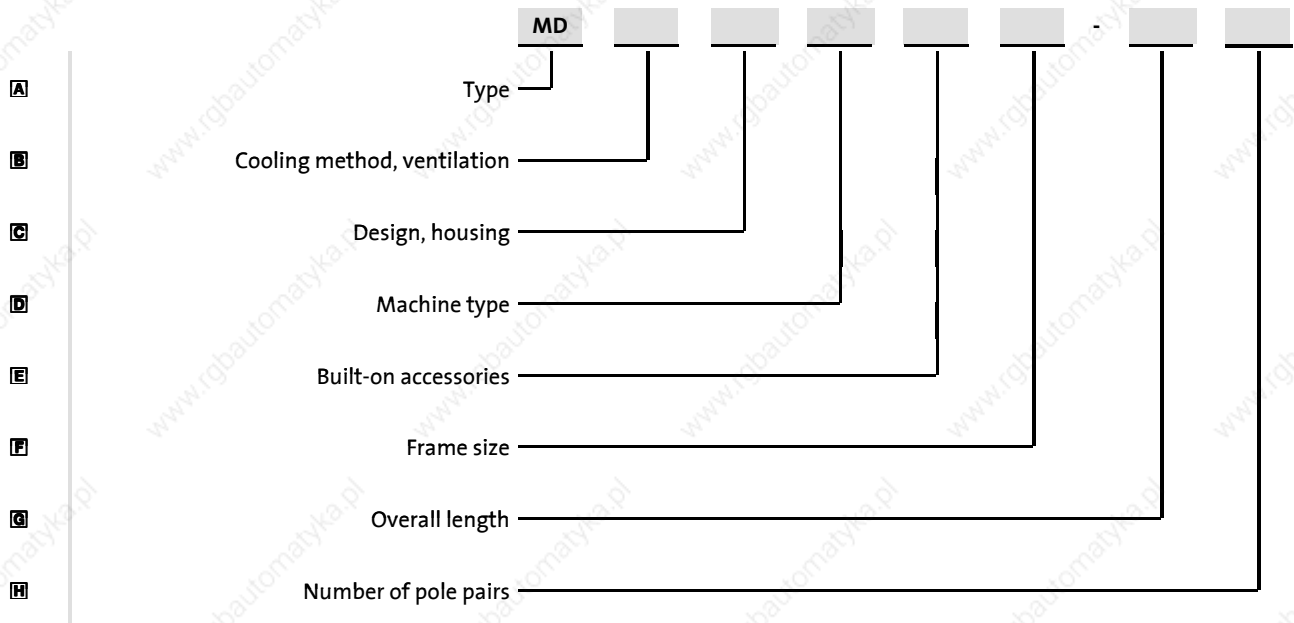









### Legend for nameplates of MDXK servo motors and MDXMA three-phase AC motors

<b>A</b>	D	Three-phase AC current		
<b>B</b>	F	Forced ventilated		
	S	Natural ventilation (cooling by convection and radiation)		
	E	Self-ventilated		
<b>C</b>	M	Modular three-phase AC motor		
	K	Compact servo motor with square housing and cooling ribs		
	Q	IP23 servo motor with square housing		
<b>D</b>	A	Asynchronous machine		
	S	Synchronous machine		
<b>E</b>	AG	Absolute value encoder		
	BA	Brake and Sin-Cos absolute value encoder or SSI absolute value encoder		
	BG	Brake, resolver and incremental encoder		
	BI	Brake and incremental encoder (pulse encoder)		
	BR	Brake		
	BS	Brake and resolver		
	BW	Brake, resolver and absolute value encoder		
	BX	Brake, encoder prepared		
	GX	No brake, encoder prepared	nM	Motor for direct gearbox attachment with shaft in acc. with module n (n = 1, 2, .....
	NN	No brake, no encoder		
	IG	Incremental encoder (pulse encoder)	RI	Resolver and incremental encoder
	RA	Resolver and absolute value encoder	RS	Resolver
<b>F</b>		036; 056; 071; 080; 090; 100; 112; 132; 160; 180		
<b>G</b>		0; 1; 2; 3		
<b>H</b>		1; 2; 3		



## What is new / what has changed in the Operating Instructions?

Material number	Edition	Important	Contents
00 408 498	1.0 03/99 TD09	1st edition	First printing
00 465 520	1.0 03/03 TD09	1st edition replaces 408 498	Completely revised
13055270	2.0 06/05 TD09	1st edition replaces 465 520	Supplement: Gearbox and brake data; Connection of incremental encoder; Example for function block interconnection

Safety instructions	
	Hazardous voltage on the power connections even when disconnected from mains: residual voltage >60 V! When carrying out work on the power connections always disconnect the controller from the mains and wait until the motor is at standstill (voltage at the contacts when the motor is rotating).
	Danger of burning! During operation, surfaces temperatures of up to 140 °C are possible. Protect against contact!
	Danger of injury through rotating shaft! Before working on motor, ensure motor is at standstill.
	Never disconnect from mains when energised! Otherwise, plug can be destroyed. Inhibit controller before disconnecting from the mains.
Mounting	
	Read these operating instructions before you start!
	<ul style="list-style-type: none"> <li>• Use an appropriate means of transport and lifting equipment!</li> <li>• The shaft must not be exposed to knocks or bumps! Motor can be destroyed! Drive elements must be mounted on the motor shaft via the threading. An extracting device must be used when dismantling. Fasten coupling securely.</li> <li>• Fasten motor and ensure unimpeded ventilation</li> <li>• If necessary, open condensation drain holes</li> <li>• Tighten coupling ring of connector</li> </ul>
	<ul style="list-style-type: none"> <li>• Motor must be carefully earthed, check cabling</li> <li>• Extensive shielding of motor cable on motor and controller</li> </ul>
	<ul style="list-style-type: none"> <li>• Maintenance interval for shaft sealing ring: approx. 2500 h</li> <li>• Maintenance interval for ball bearings: approx. 15000 h</li> <li>• Remove dirt at regular intervals</li> </ul>



### Tip!

Current documentation and software updates for Lenze products can be found on the Internet in the "Downloads" area under <http://www.Lenze.com>

© 2005 Lenze Drive Systems GmbH, Hans-Lenze-Straße 1, D-31855 Aerzen

No part of this documentation may be reproduced or made accessible to third parties without written consent by Lenze Drive Systems GmbH.

All information given in this documentation has been selected carefully and complies with the hardware and software described. Nevertheless, deviations cannot be ruled out. We do not take any responsibility or liability for damages which might possibly occur. Necessary corrections will be included in subsequent editions.

<b>1</b>	<b>Preface and general information</b> .....	<b>9</b>
1.1	About these Operating Instructions .....	9
1.2	Terminology used .....	9
1.3	Scope of supply .....	9
1.4	Legal regulations .....	10
<b>2</b>	<b>Safety instructions</b> .....	<b>11</b>
2.1	General safety and application instructions for Lenze motors .....	11
2.2	General safety and application notes for Lenze controllers .....	13
2.3	Residual hazards .....	16
2.4	Definition of notes used .....	17
<b>3</b>	<b>Technical data</b> .....	<b>18</b>
3.1	General data/operating conditions .....	18
3.2	Rated data .....	19
3.3	Sound pressure level .....	20
3.4	Holding brake (option) .....	21
3.4.1	Permanent magnet holding brakes .....	22
3.4.2	Spring-operated brakes .....	23
<b>4</b>	<b>Mechanical installation</b> .....	<b>24</b>
4.1	Transport, storage and installation .....	24
4.2	Assembly of built-on accessories .....	24
4.3	Mounting of motors on gearboxes with mounting flange (drive-end version N)	25
4.3.1	Important notes .....	25
4.3.2	Installation data .....	26
4.3.3	Tightening torques .....	27
4.3.4	Mounting the standard hub / clamping hub .....	27
4.3.5	Mounting the clamping ring hub .....	28
4.3.6	Dismounting the clamping ring hub .....	28
<b>5</b>	<b>Electrical installation</b> .....	<b>29</b>
5.1	Important notes .....	30
5.1.1	EMC-compliant wiring .....	32
5.2	Motor connection .....	32
5.2.1	Servo motors MDXK 036 ... 090, MDXK 100 ... 112, MCS 06 ... 19, MCA 10 ... 21 .....	32
5.2.2	Power connection .....	33
5.2.3	Servo motors MDFQA 100/112/132/160, three-phase AC motors MDXMA .....	34
5.3	Fan connection .....	35

5.4	Feedback connection .....	36
5.4.1	Resolver connection .....	36
5.4.2	Resolver connection .....	37
5.4.3	Sin-Cos absolute value encoder .....	37
5.4.4	Connection incremental encoder / SinCos encoder .....	38
5.4.5	Sin-Cos absolute value encoder with EnDat interface .....	39
<b>6</b>	<b>Commissioning .....</b>	<b>40</b>
6.1	Before switching on .....	40
6.2	Parameter setting .....	41
6.2.1	Servo controller 9300 .....	41
6.2.2	Servo controller ECS .....	42
6.2.3	Parameter setting of motor temperature detection .....	42
6.2.4	Parameterisation of the temperature sensor 9300 / ECS .....	42
6.3	Function block interconnection servo inverter 9300 .....	43
6.4	Parameterisation of function block interconnection .....	44
6.5	Functional test .....	45
<b>7</b>	<b>During operation .....</b>	<b>46</b>
<b>8</b>	<b>Troubleshooting and fault elimination .....</b>	<b>47</b>
<b>9</b>	<b>Maintenance/repair .....</b>	<b>49</b>
9.1	Maintenance intervals .....	49
9.2	Maintenance operations .....	49
9.2.1	Adjustment of the resolver using synchronous servo motors/rotor position adjustment .....	50
9.2.2	Temperature control for servo motors .....	50
9.3	Repair .....	51
<b>10</b>	<b>Notes .....</b>	<b>52</b>

## 1 Preface and general information

### 1.1 About these Operating Instructions

- ▶ These operating instructions serve to enhance safety when working on and with MDXK / MDFQA / MCS / MCA servo motors and MDXMA modular three-phase AC motors. They contain safety instructions which must be observed.
- ▶ All persons working on or with the stated servo motors or modular three-phase AC motors must have access to these operating instructions and observe the instructions and notes relevant for their work.
- ▶ The operating instructions must always be complete and in a perfectly readable state.
- ▶ If the information and notes provided in these operating instructions do not meet your requirements, please refer to the operating instructions for the controller and/or gearbox.

### 1.2 Terminology used

Term	Describes the following
Motor	Servo motor type MDXK, type MDFQA, type MCS, type MCA modular three-phase AC motor type MDXMA
Controller	Any servo inverter of the series 9300, ECS, 9400, 94, 940 Any frequency inverter in the series 8200
Drive system	Drive systems with servo motors type MDXK / MDFQA / MCS / MCA, with modular three-phase AC motors type MDXMA and with other Lenze drive components

### 1.3 Scope of supply

The drive systems are individually grouped. On delivery, check immediately whether it corresponds with the accompanying papers. Lenze does not grant any warranty for subsequent claims.

Claim for

- ▶ visible transport damages immediately to the forwarder.
- ▶ visible deficiencies / incomplete deliveries immediately to your Lenze representative.

# 1 Preface and general information

## Legal regulations

### 1.4 Legal regulations

Labelling	Nameplate	CE designation	Manufacturer
	Lenze motors are uniquely designated by the content of the nameplate.	Conforming to EC "Low-Voltage Directive"	Lenze Drive Systems GmbH Postfach 10 13 52 D-31763 Hameln
<b>Application as directed</b>	<p><b>MDXK / MDFQA / MCS / MCA servo motors, MDXMA modular three-phase AC motors</b></p> <ul style="list-style-type: none"> <li>can only be operated under the conditions described in these operating instructions.</li> <li>are components: <ul style="list-style-type: none"> <li>for use as small drives.</li> <li>for installation in a machine.</li> <li>used for assembly together with other components to form a machine.</li> </ul> </li> <li>comply with the requirements of the EC Low-Voltage Directive.</li> <li>are not machines within the sense of the EC Machine Directive.</li> <li>are not to be used as domestic appliances but exclusively as components for industrial applications.</li> </ul> <p><b>Drive systems with MDXK / MDFQA / MCS / MCA servo motors, with MDXMA modular three-phase AC motors</b></p> <ul style="list-style-type: none"> <li>comply with the EC Directive "Electromagnetic Compatibility" if they are installed in accordance with the guidelines for CE-typical drive systems.</li> <li>can be used: <ul style="list-style-type: none"> <li>on public and non-public mains.</li> <li>in industrial as well as residential and commercial premises.</li> </ul> </li> <li>The responsibility for ensuring that the application is in compliance with the EC Directive lies with the user.</li> </ul> <p><b>Any other use shall be deemed inappropriate!</b></p>		
<b>Liability</b>	<ul style="list-style-type: none"> <li>The information, data, and notes in these instructions were up to date at the time of printing. Claims referring to motors which have already been supplied cannot be derived from the information, illustrations and descriptions.</li> <li>The process-related notes and circuit sections used in these instructions are suggestions whose suitability for the respective application must be checked. Lenze assumes no guarantee for the suitability of the listed procedures and circuit samples.</li> <li>These operating instructions describe the product features without guaranteeing them.</li> <li>No liability shall be accepted for damage and downtimes resulting from: <ul style="list-style-type: none"> <li>non-observance of the operating instructions</li> <li>unauthorised changes or modifications to the motors</li> <li>operating errors</li> <li>improper work on and with the motors.</li> </ul> </li> </ul>		
<b>Warranty</b>	<ul style="list-style-type: none"> <li>Terms of warranty: see terms of sales and delivery of Lenze Drive Systems GmbH</li> <li>Warranty claims must be made to Lenze immediately after detecting the deficiency or fault.</li> <li>The warranty is void in all cases in which liability claims cannot be made.</li> </ul>		

## 2 Safety instructions

### 2.1 General safety and application instructions for Lenze motors

(according to Low-Voltage Directive 73/23/EEC)

#### General

Low-voltage machines have hazardous live and rotating parts and possibly also hot surfaces.

Synchronous machines induce voltages at open terminals during operation.

All operations concerning transport, connections, commissioning and maintenance must be carried out by qualified, skilled personnel (EN 50110-1 (VDE 0105-100) and IEC 60364 must be observed). Inappropriate use creates the risk of severe injury to persons and damage to material assets.

Low-voltage machines may only be operated under the conditions that are indicated in the section "Application as directed".

The conditions at the place of installation must comply with the data given on the nameplate and in the documentation.

#### Application as directed

Low-voltage machines are intended for commercial installations. They comply with the harmonised standards of the series EN 60034 (VDE 0530). Their use in potentially explosive atmospheres is prohibited unless they are expressly intended for such use (follow additional instructions).

Low-voltage machines are components for installation into machines as defined in the Machinery Directive 98/37/EC. Commissioning is prohibited until the conformity of the end product with this directive has been established (follow i. a. EN 60204-1)

Low-voltage machines with IP23 protection or less are only intended for outdoor use when applying special protective features.

The integrated brakes must not be used as safety brakes. It cannot be ruled out that factors which cannot be influenced, such as oil ingress due to a defective A-side shaft seal, cause a brake torque reduction.

#### Transport, storage

Damages must be reported immediately upon receipt to the forwarder; if required, commissioning must be excluded. Tighten screwed-in ring bolts before transport. They are designed for the weight of the low-voltage machines, do not apply extra loads. If necessary, use suitable and adequately dimensioned means of transport (e. g. rope guides).

Remove transport locking devices before commissioning. Reuse them for further transport. When storing low-voltage machines, ensure a dry, dust-free and low-vibration ( $v_{\text{eff}} \leq 0.2 \text{ mm/s}$ ) environment (damages while being stored).

**Installation**

Ensure an even surface, solid foot flange mounting and exact alignment if a direct clutch is connected. Avoid resonances with the rotational frequency and double mains frequency which may be caused by the assembly. Turn rotor by hand, listen for unusual slipping noises. Check the direction of rotation when the clutch is not active (observe section "Electrical connection").

Use appropriate means to mount or remove belt pulleys and clutches (heating) and cover them with a touch guard. Avoid impermissible belt tensions.

The machines are half-key balanced. The clutch must be half-key balanced, too. The visible jutting out part of the key must be removed.

If required, provide pipe connections. Designs with shaft end at bottom must be protected with a cover which prevents the ingress of foreign particles into the fan. Free circulation of the cooling air must be ensured. The exhaust air - also the exhaust air of other machines next to the drive system - must not be taken in immediately.

**Electrical connection**

All operations must only be carried out by qualified and skilled personnel on the low-voltage machine at standstill and deenergised and provided with a safe guard to prevent an unintentional restart. This also applies to auxiliary circuits (e. g. brake, encoder, separate fan).

Check safe isolation from supply!

If the tolerances specified in EN 60034-1; IEC 34 (VDE 0530-1) - voltage  $\pm 5\%$ , frequency  $\pm 2\%$ , waveform, symmetry - are exceeded, more heat will be generated and the electromagnetic compatibility will be affected.

Observe the data on the nameplate, operating notes, and the connection diagram in the terminal box.

The connection must ensure a continuous and safe electrical supply (no loose wire ends); use appropriate cable terminals. The connection to the PE conductor must be safe. The plug-in connector must be bolted tightly (to stop).

The clearances between blank, live parts and to earth must not fall below 8 mm at  $U_r \leq 550$  V, 10 mm at  $U_r \leq 725$  V, 14 mm at  $U_r \leq 1000$  V.

The terminal box must be free of foreign particles, dirt and moisture. All unused cable entries and the box itself must be sealed against dust and water.

### Commissioning and operation

Before commissioning after longer storage periods, measure insulation resistance. In case of values  $\leq 1 \text{ k}\Omega$  per volt of rated voltage, dry winding.

For trial run without output elements, lock the featherkey. Do not deactivate off the protective devices, not even in a trial run.

Check the correct operation of the brake before commissioning low-voltage machines with brakes.

Integrated thermal detectors do not provide full protection for the machine. If necessary, limit the maximum current. Parameterise the controller so that the motor will be switched off with  $I > I_r$  after a few seconds of operation, especially at the risk of blocking.

Vibrational severities  $v_{\text{eff}} \leq 3.5 \text{ mm/s}$  ( $P_r \leq 15 \text{ kW}$ ) or  $4.5 \text{ mm/s}$  ( $P_r > 15 \text{ kW}$ ) are acceptable if the clutch is activated.

If deviations from normal operation occur, e.g. increased temperatures, noises, vibrations, find the cause and, if required, contact the manufacturer. In case of doubt, switch off the low-voltage machine.

If the machine is exposed to dirt, clean the air channels regularly.

Shaft sealing rings and roller bearings have a limited service life.

Regrease bearings with relubricating devices while the low-voltage machine is running. Only use the grease recommended by the manufacturer. If the grease drain holes are sealed with a plug, (IP54 drive end; IP23 drive and non-drive end), remove plug before commissioning. Seal bore holes with grease. Replace prelubricated bearings (2Z bearing) after approx. 10,000 h - 20,000 h, at the latest however after 3 - 4 years.

**The product-specific safety and application notes given in these Instructions must be observed!**

## 2.2 General safety and application notes for Lenze controllers

(to: Low-Voltage Directive 73/23/EEC)

### General

Lenze controllers (frequency inverters, servo inverters, DC speed controllers) and the accessory components can include live and rotating parts - depending on their type of protection - during operation. Surfaces can be hot.

Non-authorized removal of the required cover, inappropriate use, incorrect installation or operation, create the risk of severe injury to persons or damage to material assets.

More information can be obtained from the documentation.

All operations concerning transport, installation, and commissioning as well as maintenance must be carried out by qualified, skilled personnel (IEC 364 and CENELEC HD 384 or DIN VDE 0100 and IEC report 664 or DIN VDE 0110 and national regulations for the prevention of accidents must be observed).

According to this basic safety information, qualified, skilled personnel are persons who are familiar with the assembly, installation, commissioning, and operation of the product and who have the qualifications necessary for their occupation.

**Application as directed**

Drive controllers are components which are designed for installation in electrical systems or machinery. They are not to be used as household appliances. They are intended exclusively for professional and commercial purposes according to EN 61000-3-2. The documentation includes information on compliance with the EN 61000-3-2.

When installing the controllers into machines, commissioning (i.e. starting of operation as directed) is prohibited until it is proven that the machine complies with the regulations of the EC Directive 98/37/EC (Machinery Directive); EN 60204 must be observed.

Commissioning (i.e. starting of operation as directed) is only allowed when there is compliance with the EMC Directive (89/336/EEC).

The controllers meet the requirements of the Low-Voltage Directive 73/23/EEC. The harmonised standards of the series EN 61800-5-1 apply to the controllers.

The technical data and information on connection conditions must be obtained from the nameplate and the documentation. They must be observed in any case.

**Warning:** The controllers can be used according to EN 61800-3 in drive systems of the category C2. These products can cause radio interferences in residential areas. In this case, special measures are required.

**Transport, storage**

Please observe the notes on transport, storage and appropriate handling.

Observe the climatic conditions according to EN-61800-5-1.

**Installation**

The controllers must be installed and cooled according to the instructions given in the corresponding documentation.

Ensure proper handling and avoid mechanical stress. Do not bend any components and do not change any insulation distances during transport or handling. Do not touch any electronic components and contacts.

Controllers contain electrostatically sensitive components, which can easily be damaged by inappropriate handling. Do not damage or destroy any electrical components since this might endanger your health!

### Electrical connection

When working on live controllers, the valid national regulations for the prevention of accidents (e. g. VBG 4) must be observed.

The electrical installation must be carried out according to the appropriate regulations (e.g. cable cross-sections, fuses, PE connection). Additional information can be obtained from the documentation.

The documentation contains information about installation in compliance with EMC (shielding, earthing, filters and cables). These notes must also be observed for CE-marked controllers. The manufacturer of the system or machine is responsible for the compliance with the required limit values demanded by the EMC legislation.

In the case of a malfunction (short circuit to frame or earth fault), Lenze controllers can cause a DC residual current in the protective conductor. If an earth-leakage circuit breaker (residual current device) is used as a protective means in the case of indirect contact, only an e.l.c.b. of type B may be used on the current supply side. Otherwise, another protective measure such as separation from the environment through double or reinforced insulation or disconnection from the mains by means of a transformer must be used.

### Operation

If necessary, systems including controllers must be equipped with additional monitoring and protection devices according to the valid safety regulations (e.g. law on technical equipment, regulations for the prevention of accidents). The controller can be adapted to your application. Please observe the corresponding information given in the documentation.

After a controller has been disconnected from the voltage supply, all live components and power connections must not be touched immediately because capacitors can still be charged. Please observe the corresponding stickers on the controller.

All protection covers and doors must be shut during operation.

**Note for UL approved systems with integrated controllers:** UL warnings are notes that only apply to UL systems. The documentation contains special information about UL.

### Safe standstill

Some variants of the controllers support safety functions (e. g. "safe standstill") according to the requirements of Appendix I no. 1.2.7 of the EC Directive "Machinery" 98/37/EC, EN 954-1 category 3 and EN 1037. The notes on the safety instructions in the documentation of the variants must be strictly observed.

### Maintenance and servicing

The controllers do not require any maintenance if the prescribed conditions of operation are observed.

If the ambient air is polluted, the cooling surfaces of the controller may become dirty or the air vents of the controller may be obstructed. Therefore, clean the cooling surfaces and air vents periodically under these operating conditions. Do not use sharp or pointed tools for this purpose!

**Disposal**

Recycle metal and plastic materials. Ensure professional disposal of assembled PCBs.

**The product-specific safety and application notes given in these Instructions must be observed!**

**2.3****Residual hazards****Protection of persons**

- ▶ The motor surfaces can become very hot. Danger of burns when touching!
  - If necessary, provide protection against contact.
- ▶ If the motor is inverter driven, high-frequency voltages may be capacitively transferred to the motor housing.
  - Ensure careful earthing of motor housing.
- ▶ Danger through unintended starts or electric shocks
  - Connections must only be made when the equipment is deenergised and the motor is at standstill.
  - Built-in brakes are not fail-safe brakes .

**Device protection**

- ▶ Integrated temperature sensors do not provide **full protection** for the machine.
  - If necessary, limit the maximum current, perform a function block interconnection with disconnection after a few seconds of operation with  $I > I_N$ , particularly if a danger of blocking exists.
  - Integrated overload protection does not protect against overloading under all conditions.
- ▶ Built-in brakes are **not fail-safe brakes** .
  - Torque can be reduced.
- ▶ Fuses do not protect the motor.
  - Use current-dependent motor protection switches for average switching frequency.
  - Use integrated temperature sensor for high switching frequency.
- ▶ Excessive torques may lead to demagnetisation or a breakage of the motor shaft.
  - Never exceed the maximum torques specified in the catalogue.
- ▶ Shear forces from the motor shaft are possible.
  - Shafts of motor and drive machine must be exactly aligned.

**Fire protection**

- ▶ Danger of fire
  - Avoid contact with inflammable substances.

## 2.4 Definition of notes used

The following signal words and symbols are used in this documentation to indicate dangers and important information:

### Safety instructions

Structure of safety instructions:



#### **Danger!**

(characterises the type and severity of danger)

#### **Note**

(describes the danger and gives information about how to prevent dangerous situations)

Pictograph and signal word	Meaning
<b>Danger!</b>	<b>Danger of personal injury through dangerous electrical voltage.</b> Reference to an imminent danger that may result in death or serious personal injury if the corresponding measures are not taken.
<b>Danger!</b>	<b>Danger of personal injury through a general source of danger.</b> Reference to an imminent danger that may result in death or serious personal injury if the corresponding measures are not taken.
<b>Stop!</b>	<b>Danger of property damage.</b> Reference to a possible danger that may result in property damage if the corresponding measures are not taken.

### Application notes

Pictograph and signal word	Meaning
<b>Note!</b>	Important note to ensure trouble-free operation
<b>Tip!</b>	Useful tip for simple handling
	Reference to another documentation

### 3 Technical data

#### General data/operating conditions

### 3 Technical data

#### 3.1 General data/operating conditions

Field	Values		
Conformity	CE	Low-Voltage Directive (73/23/EEC)	
Approvals	UL 1004	Underwriter Laboratories (File No. E210321)	
Climatic conditions	Average relative humidity 85 %, without condensation		
Permissible temperature ranges	Designs		
	<ul style="list-style-type: none"> <li>Non-ventilated or with integral fan without brake or with spring-operated brake</li> </ul>	-20 °C ... +40 °C	Without power reduction, over +40°C with power reduction, see catalogue
	<ul style="list-style-type: none"> <li>With permanent magnet brake</li> </ul>	-10 °C ... +40 °C	
	<ul style="list-style-type: none"> <li>With separate fan, without permanent magnet brake</li> </ul>	-15 °C ... +40 °C	Without power reduction
Mounting positions	Suitable for all mounting positions		Vertical arrangements to DIN-IEC 34 Part 7 are possible if they meet the designs
Protection type	See nameplate		Protection types only apply for horizontal installation
Thermal class	F (155 °C) to DIN-IEC 34 / VDE 0530		If the temperature limit is exceeded, the insulation will be damaged or destroyed
Tropical insulation	Can not be guaranteed		
Permissible installation height h	h ≤ 1000 m AMSL		Without power reduction
	1000 m AMSL < h ≤ 4000 m AMSL		With power reduction, see catalogue
Permissible voltage	1.5 kV peak value		5 kV/μs rate of rise
Vibration	Up to 2.0g / 20m/s <sup>2</sup> without resonance excitation, e.g. of the fan.		

3.2

Rated data

Rated data	Values	Comment
Motor, separate fan	See respective nameplate Further data is provided in the catalogue.	The specified values apply: <ul style="list-style-type: none"> <li>for MDXK, MDFQA, MCS, MCA servo motors for operation with Lenze servo inverters 9300, ECS for operation with 400 V mains and an inverter clock frequency of 4 kHz, 8 kHz and 16 kHz.</li> <li>for MDXM modular three-phase AC motors for mains operation or for operation with Lenze frequency inverters from 4 ... 16 kHz.</li> </ul>
Maximum motor speed [min <sup>-1</sup> ] (mechanical limit)	<ul style="list-style-type: none"> <li>Synchronous servo motors MCS: 4000 ... 8000</li> <li>Synchronous servo motors MDXKS: 5000 ... 8000</li> <li>Asynchronous servo motors MDXKA, MCA: 8000</li> <li>Asynchronous servo motors MDFQA: 4500 ... 5000</li> <li>Modular three-phase AC motors: 4500</li> </ul>	
Weights	See catalogue	The specified values serve as reference values for dimensioning.
Torques	See catalogue	<ul style="list-style-type: none"> <li>Torques that exceed the maximum values lead to shaft breakage or demagnetisation.</li> <li>The maximum torque values indicated in the catalogue must be observed.</li> <li>The indicated torques can be achieved through the utilisation of corresponding motor-controller combinations.</li> </ul>
Axial forces	See catalogue	Excessive forces reduce the service life of the bearings.
Radial forces	See catalogue	<ul style="list-style-type: none"> <li>Please observe the permitted forces indicated in the catalogue.</li> </ul>



**Note!**

MDXKA / MDFQA / MCS / MCA asynchronous motors and MDXMA modular three-phase AC motors can also be operated with other inverters. Please observe the minimum clock frequency indicated in the table. Depending on the modulation and control characteristic of the inverter, the temperature monitoring of the motor may be activated. If this is the case, reduce the power.

Motor type	Minimal inverter clock frequency [kHz]
MDXKA 056 ... 080 / MCA 10 ... 21	4
MDXKA 090 ... 112	4
MDFQA	8
MDXMA	4
MCS	4

## 3.3

### Sound pressure level

Motor type	Fan operation	Sound pressure level [db (A)]	Comments
MDSKA 056		60	Sound pressure level, A-weighting Distance = 1 m Motor in no-load operation, U = 3400 min <sup>-1</sup>
MDSKA 071		60	
MDFKA 071	X	62	Operation with 9300 servo inverters or 8200 frequency inverter Inverter clock frequency: 8 or 16 kHz
MDSKA 080		62	
MDFKA 080	X	64	
MDSKA 090		63	
MDFKA 090	X	66	
MDSKA 100		69	
MDFKA 100	X	72	
MDSKA 112		72	
MDFKA 112	X	75	
MDFQA 110	X	81	
MDFQA 112	X	84	
MDFQA 132	X	87	
MDFQA 160	X	89	
MDFMA	X	≤ 70	



#### Note!

The noise generated by motors with a separate fan can be reduced if they are operated with a 9300 servo:

- ▶ If the application does not require permanent ventilation with a separate fan (e.g. intermittent operation with long cooling periods), the fan should only be activated if the winding temperature exceeds a certain limit.
- ▶ We recommend: from 120 °C upwards

### 3.4 Holding brake (option)

The MDXKX, MCA and MCS servo motors can be equipped with permanent magnet holding brakes (option). The enclosed-ventilated MDFQA asynchronous servo motors and the MDXMA three-phase AC motors can be equipped with a spring-operated brake. The installation or mounting of the brakes increases the length of the motor.

**The brakes used are not fail-safe brakes in the sense that a torque reduction cannot occur through uncontrollable interference factors, such as through the entrance of oil.**

With long motor supply cables, the ohmic voltage drop along the cable must be observed and compensated for by a higher voltage at the cable entry.

The following applies to Lenze system cables:

$$U^* [V] = U_B [V] + (0.08 \left[ \frac{V}{m \cdot A} \right] \cdot L [m] \cdot I_B [A])$$

U*	Resulting supply voltage
U <sub>B</sub>	Rated voltage of the brake
L	Length of cable
I <sub>B</sub>	Rated current of the brake



#### Stop!

If no suitable voltage (incorrect size, incorrect polarity) is applied to the brake, the brake is applied and can overheat and be destroyed by the motor which continues to run.

The shortest operating times of the brakes are achieved by switching the voltage on the DC side and a suppressor circuit (varistor or spark suppressor). Without suppressor circuit, the operating times may increase. A varistor/spark suppressor limits the breaking voltage peaks. It must be observed that the power limit of the suppressor circuit is not exceeded. It is dependent on the brake current, brake voltage, disengagement time and the switchings per time unit.

The suppressor circuit is also required for radio interference suppression and for increasing the service life of the relay contacts (external, not integrated in the motor).

## 3.4.1 Permanent magnet holding brakes

These brakes serve as a holding brake to hold the axles when the machine is at standstill or deenergised. When controlling the brake it must be ensured that the brake is activated (released, engaged) at a speed of 0 min<sup>-1</sup> to avoid unnecessary and rapid wear on the friction surfaces of the brake.

When used solely as a holding brake, practically no wear occurs on the friction surfaces. If the max. permissible switching energy per emergency stop (see catalogue) is not exceeded, at least 2000 emergency stop functions are possible at a speed of 3000 min<sup>-1</sup>.

$W = \frac{1}{2} \cdot J_{\text{total}} \cdot \omega^2$	W [J]	Energy
	$J_{\text{total}}$ [kgm <sup>2</sup> ]	Total moment of inertia
	$\omega$ [1/s]	Angular speed $\omega = 2\pi \cdot n / 60$ , n = speed [min <sup>-1</sup> ]

The holding torques specified in the catalogue only apply when the motor is at standstill. In the case of a slipping brake, the dynamic braking torque always applies.

**Stop!**

The holding brake is only designed for a limited number of emergency stops. Utilisation as a working brake, e.g. to decelerate a load, is not permissible.

**Note!**

The brakes are maintenance-free and cannot be adjusted. In the event of wear, e.g. through emergency stops, the brakes must be replaced.

These brakes function in accordance with the closed-circuit principle, i.e. the brake is closed when the motor is deenergised.

Brakes with a rated voltage of DC 24 V are designed for smoothed DC voltages with a ripple of <1 %. It must be ensured that the connector on the motor side is supplied with the minimum voltage of DC 24 V -10 %. If necessary, the voltage drop in the cable should also be considered. If the maximum voltage DC 24 V + 5 % is exceeded, the brake can close again. Supplying the brake with bridged DC voltage (bridge rectifier without additional smoothing) or a DC voltage with a ripple of >1 % can lead to a malfunctioning of the brake or an increase in the engagement and disengagement times.

Brakes with a rated voltage of DC 205 V are designed for bridged DC voltage, i.e. for supply via a bridge rectifier from the 230 V mains (half-wave rectifier are not permissible). Supplying the brake with smoothed DC voltage can lead to a malfunction or an increase in the linking and disengagement times. With regard to the minimum and maximum voltages, the same conditions apply as for brakes with 24 V, i.e. the permissible voltage tolerance is 205 V DC +5 %, -10 %.

### 3.4.2 Spring-operated brakes

The spring-operated brakes serve as a holding brake to hold the axles when the machine is at standstill or deenergised. Permissible operating speeds and characteristics (📖 catalogue for spring-operated brakes). Emergency stops at higher speeds are possible but high switching energy increases wear on the friction surfaces and hub.



#### Stop!

In any case, the friction surfaces must be kept free of lubricant and grease, since even small amounts can drastically reduce the braking torque.

When used solely as a holding brake, very little wear occurs on the friction surfaces. Emergency stops lead to wear on the friction surfaces and also lead to the creation of dust. The lenze BFK 458 spring-operated brake can be adjusted up to 5 times. The BFK 418, 457 and 460 cannot be adjusted (Details 📖 catalogue and operating instructions for spring-operated brakes). Brakes that cannot be adjusted must be replaced once the wear limit has been reached.

The friction energy per switching cycle can be calculated using the formula below and may not exceed the limit value (depends on the switching rate) for emergency stops (📖 catalogue on spring-operated brakes).

$Q = \frac{1}{2} \cdot J_{\text{total}} \cdot \Delta\omega^2 \cdot \frac{M_K}{M_K - M_L}$	Q [J]	Friction energy
	$J_{\text{total}}$ [kgm <sup>2</sup> ]	Total mass moment of inertia (motor + load)
	$\Delta\omega$ [1/s]	Angular speed $\omega = 2\pi \cdot n / 60$ , n = speed [min <sup>-1</sup> ]
	$M_K$ [Nm]	Characteristic torque
	$M_L$ [Nm]	Load torque

Depending on the operating conditions and possible heat removal, the surface temperatures can reach up to 130 °C.

The spring-operated brakes operate according to the closed-circuit principle, i.e. the brake is closed in the deenergised state. The brakes can be fed with a bridged DC voltage (bridge rectifier) and a smoothed DC voltage. The permissible voltage tolerance is ±10%.



#### Note!

For additional information see the catalogues and operating instructions for spring-operated brakes.

## 4 Mechanical installation

### Transport, storage and installation

## 4 Mechanical installation

### 4.1 Transport, storage and installation

<b>Transport</b>	<ul style="list-style-type: none"><li>● Motors may only be transported using a suitable means of conveyance and appropriate hoists.<ul style="list-style-type: none"><li>– Ensure secure fastening: the motors are partially equipped with transport eyelets that are intended for secure fastening to hoists. They are <b>only</b> designed for the weight of the motor and must <b>not</b> be used if other components are mounted to the motor (weights: see catalogue).</li></ul></li><li>● Ensure vibration-free transport of motors.</li><li>● The motors must not be exposed to hard knocks and bumps.</li></ul>
<b>Storage location</b>	<ul style="list-style-type: none"><li>● Vibration-free<ul style="list-style-type: none"><li>– If vibrations cannot be avoided, the rotor must be rotated in the bearings once a week.</li></ul></li><li>● Dry, non-aggressive atmosphere</li><li>● Dust-free</li><li>● Without sudden temperature changes</li><li>● In the delivery state, all steel components have corrosion protection. Do not remove the protection! Check every three months and replace, if necessary.</li></ul>
<b>Installation</b>	<ul style="list-style-type: none"><li>● Provide fixings which correspond to the design, weight and torque of the motor.</li><li>● The foot and flange surfaces of the motor must be fitted evenly before the motor is fastened.<ul style="list-style-type: none"><li>– Incorrect motor alignment reduces the service life of the roller bearings and transmission elements.</li></ul></li><li>● Couplings and other transmission elements must be fitted in accordance with the regulations.<ul style="list-style-type: none"><li>– Impacts on shafts can cause bearing damage (▢ Ch. 4.2).</li></ul></li><li>● Do not exceed the permissible range of ambient operating temperature (▢ Ch. 3.1).</li><li>● Humidity ≤ 85%, non-condensing</li><li>● Vibration ≤ 2g / 20m/s<sup>2</sup> without resonance excitation</li><li>● Fasten motor securely</li><li>● Ensure that ventilation is not impeded</li><li>● During operation, surfaces are hot, up to 140 °C! Ensure that guard is in place!</li></ul>

### 4.2 Assembly of built-on accessories

Follow these instructions carefully. Please note that the warranty and product liability will become void in the event of impermissible alterations or modifications to the motors.

- ▶ For new motors, you may have to remove the corrosion protection from the shaft ends and flanges. In this case, ensure that no solvent enters the bearings!
- ▶ The mounting dimensions are standard dimensions in accordance with IEC 34.
- ▶ Attach transmission elements:
  - shocks and impacts must be avoided! They could destroy the motor.
  - use the centre bore in the motor shaft in accordance with DIN 332, design D.
  - tolerances of the shaft ends:  
≤ Ø 50 mm: ISO k6, > Ø 50 mm: ISO m6.
- ▶ Dismounting must only be carried out with an extracting device.
- ▶ When using belts for torque / power transmission:
  - check the belt tension
  - observe the permissible radial forces specified in the catalogue.

## Mounting of motors on gearboxes with mounting flange (drive-end version N) Important notes

### 4.3 Mounting of motors on gearboxes with mounting flange (drive-end version N)

#### 4.3.1 Important notes



#### Stop!

- ▶ In the case of impact load or load alternation, use a coupling hub with a clamping hub or clamping ring hub.
- ▶ If necessary, replace the featherkey of the motor with a shorter featherkey (Tab. 1).
- ▶ The motor shaft should not be exposed to knocks during assembly.

1. Fasten coupling hub with mounting dimension "m" as shown in Tab. 1, the motor shaft must not be exposed to knocks!
2. Connect the motor and the gearbox to the spider.
3. Fasten motor.

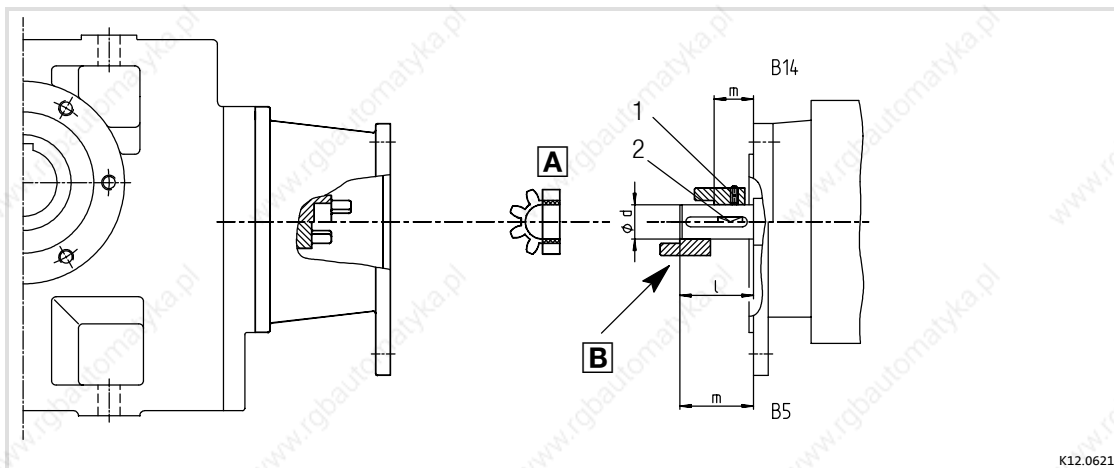

K12.0621

Fig. 1 Drive-end version N

- A** Spider
- B** Coupling hub

## 4

### Mechanical installation

Mounting of motors on gearboxes with mounting flange (drive-end version N)

Installation data

#### 4.3.2 Installation data

MDXKX	Lenze motor				Motor shaft		Featherkey <sup>1)</sup> DIN 6885/1 [mm]	Drive size	Mounting dimension m [mm]
	MDFQA	MDXMA	MCA	MCS	d [mm]	l <sub>max.</sub> [mm]			
MDSKS 036		MDXMA 063		MCS 06	11	23	2)	1A	23
MDSKX 056		MDXMA 071	MCA 10		14	30		1B	30
MDSKS 036		MDXMA 063			11	23		2B	23
MDXKX 071		MDXMA 080	MCA 13	MCS 06	19	40	B 6 x 6 x 16	1C	25
					14	40		2C	25
MDSKX 056		MDXMA 071	MCA 10		14	40	B 5 x 5 x 16	3C	25
		MDXMA 071		MCS 09	14	40		4C	25
MDXKA 080 MDXKA 090		MDXMA 090	MCA 14 MCA 17		24	50	2)	1D	50
MDXKX 071			MCA 13	MCS 12	19	40-50		2D	50
MDXKA 100		MDXMA 100 MDXMA 112	MCA 19		28	30-60	B 8 x 7 x 18	1E	30
MDXKA 080 MDXKA 090		MDXMA 090	MCA 14 MCA 17		24	30-60		2E	30
				MCS 14	24	50		2E with flange	50
MDXKX 071		MDXMA 080	MCA 13	MCS 12	19	30-60	B 6 x 6 x 18	3E	30
MDXKA 100		MDXMA 100 MDXMA 112	MCA 19	MCS 12	28	30-60	B 8 x 7 x 18	1F	30
MDXKA 080 MDXKA 090		MDXMA 090	MCA 14 MCA 17		24	30-60		2F	30
				MCS 14	24	50		2F with flange	50
MDXKA 112	MDFQA 100 MDFQA 112	MDXMA 132	MCA 21		38	80	2)	1G	80
MDXKA 100			MCA 19	MCS 19	28	60		2G	60
					38	80		3G	80
		MDXMA 160			42	110	2)	1H	110
		MDXMA 180			48	110		2H	110
MDXKA 112	MDFQA 100 MDFQA 112	MDXMA 132	MCA 21		38	80	2)	3H	80
	MDFQA 132 MDFQA 160	MDXMA 200			55	110		1K	110
		MDXMA 225			60	140		2K	140

Tab. 1 Mounting data for motors on gearboxes with mounting flange

- 1) Featherkey required when mounting with standard or clamping hub
- 2) Use original featherkey for motor!

## Mounting of motors on gearboxes with mounting flange (drive-end version N) Tightening torques

### 4.3.3 Tightening torques

Drive size	Standard hub Locking screw	Clamping hub Terminal screw		Clamping ring hub Clamping screw	
	Thread [mm]	Thread [mm]	Tightening torque [Nm]	Thread [mm]	Tightening torque [Nm]
1A	M4	M3	1.3	M3	1.3
1B	M4	M3	1.3	M3	1.3
2B					
1C	M5	M6	10.5	M4	2.9
2C					
3C					
4C					
1D	M5	M4	2.9	---	---
2D		M6	10.5	M4	2.9
1E	M5	M6	10.5	M5	6
2E					
2E with flange					
3E	M5	M6	10.5	M5	6
1F					
2F	M5	M6	10.5	M5	6
2F with flange					
1G	M6	M8	25	M5	6
2G					
3G					
1H	M8	M10	69	---	---
2H					
3H					
1K	M8	M10	69	M8	35
2K				---	---

Tab. 2 Tightening torques of hub connections

### 4.3.4 Mounting the standard hub / clamping hub

- Mounting the motor featherkey (2).
  - When using drive sizes □C, □E, □F, mount the featherkey that is provided.
- Push the coupling hub onto the motor shaft observing mounting dimension m.
- Secure the coupling hub against axial movement using the locking screw or terminal screw (1).
- Place spider (ring gear) in the coupling claw at the gear end.
- Align the coupling hub at the motor side with the counterpart.
- Slowly slide on motor and fasten to the flange of the gear unit.

## Mechanical installation

Mounting of motors on gearboxes with mounting flange (drive-end version N)

Mounting the clamping ring hub

### 4.3.5

#### Mounting the clamping ring hub

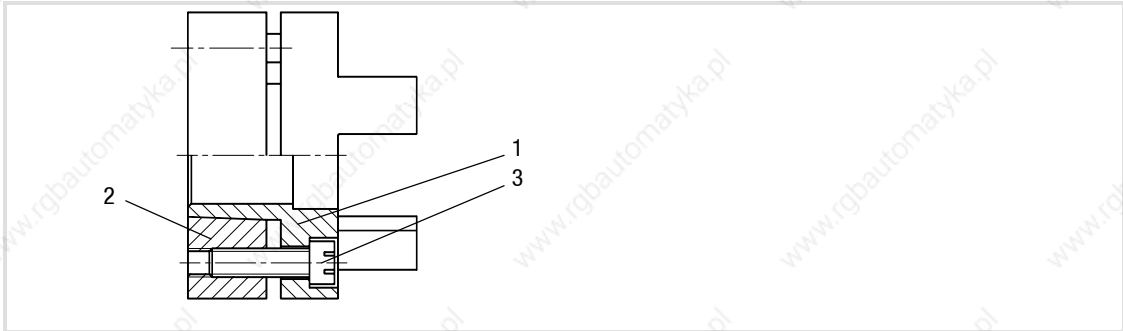

Fig. 2

Coupling

- |   |                         |
|---|-------------------------|
| 1 | Clamping ring hub       |
| 2 | Clamping ring           |
| 3 | Clamping screw (DIN912) |

1. Push coupling hub onto the motor shaft observing mounting dimension “m” (see Fig. 2 and Tab. 1).
2. Align hub and slightly tighten clamping screws.
3. Tighten screws evenly and crosswise using a torque spanner until all clamping screws have been tightened to the specified tightening torque.
4. Place spider (ring gear) in the coupling claw at the gear end.
5. Align the coupling hub at the motor side with the counterpart.
6. Slowly slide on motor and fasten to the flange of the gear unit.

### 4.3.6

#### Dismounting the clamping ring hub

1. Gradually and evenly loosen the clamping screws.
2. Remove the screws next to the jacking screw threads and screw these into thread that is provided only tightening the screws slightly.
3. When the screws in the jacking screw threads are gradually and evenly tightened crosswise the clamping ring will be pushed off the conical clamping ring hub.
4. All contact surfaces including the threads and head contact areas of the clamping screws should be cleaned and oiled slightly prior to reassembly.

## 5 Electrical installation



### Stop!

Electrical connections must be carried out in accordance with the national and regional regulations!

## 5.1

## Important notes

**Danger!**

Hazardous voltage at the power terminals, even if the plug is removed:  
residual voltage > 60 V!

Before working at the power terminals, disconnect the drive controller from the mains and wait until the motor stands still (voltage at the contact while the motor is turning).

<b>General information</b>		<ul style="list-style-type: none"> <li>Observe the notes in the terminal box of the motor.</li> <li>Make sure that the terminal bridges are arranged correctly.</li> <li>Tighten all screw connections.</li> <li>Connect PE conductor to earthing screw.</li> <li>Use a strain relief for the connecting cable.</li> <li>The motor must be earthed carefully.</li> </ul>
<b>Voltage supply</b>	Servo motors	<ul style="list-style-type: none"> <li>Servo motors must be supplied by servo inverters.</li> <li>Connect the integrated encoder at the motor side with the corresponding connections of the servo inverter.</li> </ul>
	Holding brake (optional)	<ul style="list-style-type: none"> <li>DC supply in accordance with nameplate on brake or AC supply via upstream rectifier (only spring-operated brakes, PM brakes 205 V<sup>1)</sup>).</li> <li>Brakes for 205 V can be fed from the 230 V mains via bridge rectifiers, brakes for 103 V from the 115 V mains.</li> <li>Brakes must not be supplied from AC mains using half-wave rectifiers.</li> </ul>
<b>Inverter operation</b>		<ul style="list-style-type: none"> <li>Observe the connection information in the corresponding operating instructions.</li> <li>Make sure that the motor and inverter are correctly assigned.</li> <li>Special attention must be paid to the speed limit and the winding load.<sup>2)</sup></li> </ul>
<b>Cable cross-section</b>		<ul style="list-style-type: none"> <li>Connecting cables must be correctly dimensioned to ensure that no impermissible heating occurs.</li> <li>Adhere to the minimum cross-section in acc. with DIN 57100 and fuse appropriately.</li> </ul>
<b>Motor protection</b>	Protection against overload	<ul style="list-style-type: none"> <li>Standard current-dependent motor protection switches for average switching               <ul style="list-style-type: none"> <li>Setting to the rated current indicated on the nameplate.</li> </ul> </li> <li>For very high switching rates: use Lenze three-phase AC motors with thermal switches or PTC thermistors in the winding.               <ul style="list-style-type: none"> <li>The thermal switches are integrated in the winding as NO contact or NC contact. The response temperature is permanently set.</li> </ul> </li> </ul>
	Motor supply cable	<ul style="list-style-type: none"> <li>No protection possible through the overtemperature protector switch or PTC thermistor of the motor winding               <ul style="list-style-type: none"> <li>Take measures according to DIN 57100 / VDE 0530.</li> </ul> </li> </ul>
	Inverter operation	<ul style="list-style-type: none"> <li>The current or voltage conversion can increase the output current significantly above the input current.               <ul style="list-style-type: none"> <li>The motor supply cable cannot be fused via the mains input fuses of the inverter. Take measures according to DIN 57100 / VDE 0530.</li> </ul> </li> </ul>

1) Supply PM brakes for 24 VDC only with smooth DC voltage (ripple ≤1%)

2) Voltage limits: 1.5 kV peak value, 5 kV/μs rate of rise; further information: catalogue.

**Stop!**

The bore holes in the terminal box are closed with plugs to enhance protection during transport. These must be replaced with screw fittings or blanking plugs to meet the requirements of the protection type.

In the case of MCS motors, the openings are cast closed and can be opened by the customer as required.

Power connections and connection studs when mounting terminal box			
Motor type	Power connection		Encoder/fan connection
	Screwed connections	Connection terminal	Screwed connections
MDSK 056 / MCA 10	1 x M20 x 1.5 + 1 x M16 x 1.5	0.08 ... 2.5 mm <sup>2</sup>	1 x M20 x 1.5 + 1 x M16 x 1.5
MDSK 071 / MCA 13			
MDSK 080 / MCA 14			
MDSK 090 / MCA 17			
MDSK 100 / MCA 19	1 x M32 x 1.5 + 1 x M25 x 1.5	0.2 ... 10 mm <sup>2</sup>	
MDSK 112 / MCA 21			
MCS 09; MCS 12; MCS 14D, MCS 14H; MCS 14L15; MCS 14P14; MCS 19F15; MCS 19J15	2 x M20 + 2 x M25 + 2 x M32	0.08 ... 2.5 mm <sup>2</sup> (4 mm <sup>2</sup> without wire end ferrule)	In the case of MCS motors only one terminal box is used for power and encoder
MCS 14L32; MCS 14P32; MCS 19F30; MCS 19J30; MCS 19P		0.2 ... 10 mm <sup>2</sup>	
	Power connection		Fan connection
	Screwed connections	Connection studs	Screwed connections
MDFQA 100	1 x M40 x 1.5 + 1 x M20 x 1.5 + 1 x M16 x 1.5	M6	1 x M16 x 1.5
MDFQA 112	1 x M50 x 1.5 + 1 x M20 x 1.5 + 1 x M16 x 1.5	M8	1 x M16 x 1.5
MDFQA 132	1 x M63 x 1.5 + 1 x M50 x 1.5 + 2 x M16 x 1.5	M12	1 x M16 x 1.5
MDFQA 160	2 x M63 x 1.5 + 1 x M16 x 1.5	M12	1 x M20 x 1.5

Tab. 3 Power connections and connection studs

### 5.1.1 EMC-compliant wiring

The EMC-compliant wiring of the motors is described in detail in the operating instructions of the Lenze servo inverters 9300 and ECS.

- ▶ Utilisation of EMC screwed metal connections with shield connection or extensive shield connection on the corresponding surfaces in the terminal box (MCS).
- ▶ Shield connection on the motor and on the device.

## 5 Electrical installation

### Motor connection

Servo motors MDXK 036 ... 090, MDXK 100 ... 112, MCS 06 ... 19, MCA 10 ... 21

### 5.2 Motor connection



#### Stop!

- ▶ Tighten coupling ring of connector.
- ▶ Also add O-ring in the event of vibrations:
  - power connection MDXK 036...090: O-ring 18 x 1.5 mm
  - power connection MDXK 100...112: O-ring 27 x 4 mm
  - encoder, fan connection, MDXK: O-ring 18 x 1.5 mm
  - power connection MCA and MCS: O-ring already installed
  - encoder, fan connection MCA and MCS: O-ring already installed
- ▶ Do not disconnect from the mains when the machine is energised! The plug could be destroyed! Inhibit the controller before disconnecting from the mains.

#### 5.2.1 Servo motors MDXK 036 ... 090, MDXK 100 ... 112, MCS 06 ... 19, MCA 10 ... 21

Connector (external view of poles)			Size 1.0; M23	
Pin	Meaning		MDXK 036 ... 090, MCS 06 ... 19, MCA 10 ... 17	MDXK 100 ... 112 without UR approval
1	Y1 / BD1	Holding brake + Holding brake -		
2	Y2 / BD2			
⊕	PE	PE conductor		
4	U	Power phase U		
5	V	Power phase V		
6	W	Power phase W		
Connector (external view of poles)			Size 1.5; M40	
Pin	Meaning		MDXK 100 ... 112, MCS 14 ... 19, MCA 19 ... 21	
+	Y1 / BD1	Holding brake + Holding brake -		
-	Y2 / BD2			
⊕	PE	PE conductor		
U	U	Power phase U		
V	V	Power phase V		
W	W	Power phase W		
Terminal box			MDXK 036 ... 112, MCS 09 ... 19, MCA 10 ... 21	
Terminal	Meaning			
U	U1	Motor winding phase U		
V	V1	Motor winding phase V		
W	W1	Motor winding phase W		
Y1 / BD1	+	Holding brake		
Y2 / BD2	-			
S1 / TB1	Thermostat (NC contact)			
T1	+ KTY	Temperature sensor KTY		
T2	-KTY			
P1 / TP1	PTC			
P2 / TP2	PTC			

5.2.2 Power connection

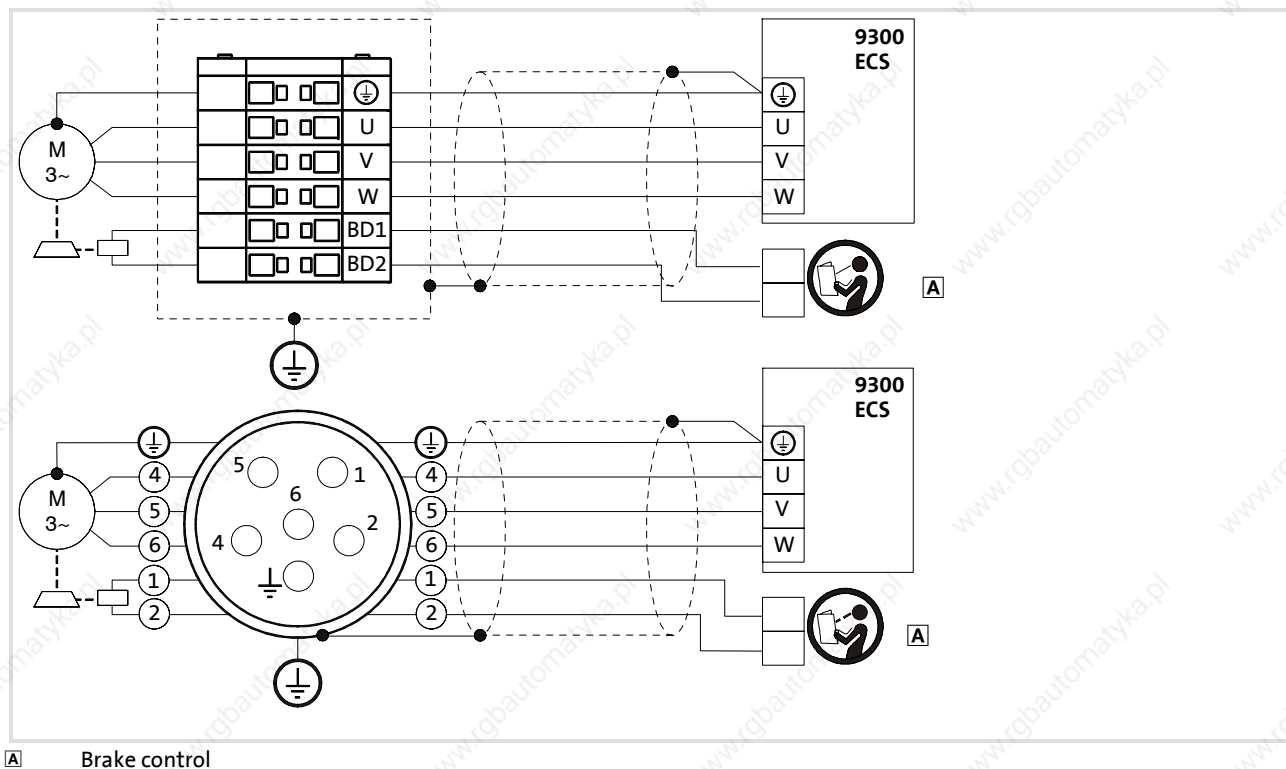

A Brake control

## 5 Electrical installation

### Motor connection

Servo motors MDFQA 100/112/132/160, three-phase AC motors MDXMA

### 5.2.3 Servo motors MDFQA 100/112/132/160, three-phase AC motors MDXMA

Terminal box			MDFQA 100	MDFQA 112/132/160, MDXMA
Terminal		Meaning		
1 2 3	U1 V1 W1	Motor winding phase U Motor winding phase V Motor winding phase W		<p>Star connection</p> <p>Delta connection</p>
⊕	PE	PE conductor for motor housing		
S1 / TB1 S2 / TB2		Thermostat (NC contact)		
T1 T2	+ KTY -KTY	Temperature sensor KTY		

### 5.3 Fan connection

#### MDXKX 071 ... 112

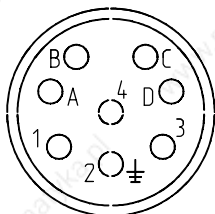
Connector (external view of poles)			Size 1.0; M23
Pin	Meaning		
1		Not assigned	
2	PE	PE conductor	
3		Not assigned	
4		Not assigned	
A	L1	Winding - fan	
B	N		
C		Not assigned	
D		Not assigned	

K33.0018/4

#### MCA 13 ... 21

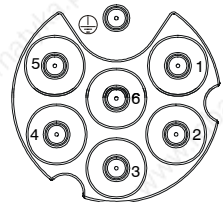
Connector (external view of poles)			Size M17
Pin	Meaning		
⊕	PE	PE conductor	
1	L1	Winding - fan	
2	N		

N

## 5 Electrical installation

Feedback connection  
Resolver connection

### 5.4 Feedback connection

#### 5.4.1 Resolver connection

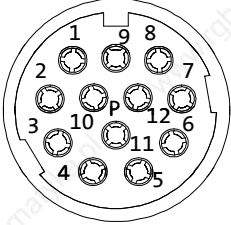
Connector (external view of poles)			
Pin	Meaning		Size 1.0; M23
1	+ Ref	Transformer winding (Reference winding)	 <p>0° coded</p>
2	- Ref		
3	+VCC ETS	Supply: electronic nameplate <sup>1)</sup>	
4	+ Cos	Stator windings cosine	
5	- Cos		
6	+ Sin	Stator windings Sine	
7	- Sin		
8		Not assigned	
9			
10			
11	+ KTY	Temperature sensor KTY	
12	-KTY		

Terminal box																																																																																																																											
Terminal	Meaning																																																																																																																										
T1	+ KTY	Temperature sensor KTY	<table border="1"> <tr><td>T1</td><td><input type="checkbox"/></td><td><input type="checkbox"/></td><td><input type="checkbox"/></td></tr> <tr><td>T2</td><td><input type="checkbox"/></td><td><input type="checkbox"/></td><td><input type="checkbox"/></td></tr> <tr><td>S1</td><td><input type="checkbox"/></td><td><input type="checkbox"/></td><td><input type="checkbox"/></td></tr> <tr><td>S2</td><td><input type="checkbox"/></td><td><input type="checkbox"/></td><td><input type="checkbox"/></td></tr> <tr><td>B1</td><td><input type="checkbox"/></td><td><input type="checkbox"/></td><td><input type="checkbox"/></td></tr> <tr><td>B2</td><td><input type="checkbox"/></td><td><input type="checkbox"/></td><td><input type="checkbox"/></td></tr> <tr><td>B3</td><td><input type="checkbox"/></td><td><input type="checkbox"/></td><td><input type="checkbox"/></td></tr> <tr><td>B4</td><td><input type="checkbox"/></td><td><input type="checkbox"/></td><td><input type="checkbox"/></td></tr> <tr><td>B5</td><td><input type="checkbox"/></td><td><input type="checkbox"/></td><td><input type="checkbox"/></td></tr> <tr><td>B6</td><td><input type="checkbox"/></td><td><input type="checkbox"/></td><td><input type="checkbox"/></td></tr> <tr><td>B7</td><td><input type="checkbox"/></td><td><input type="checkbox"/></td><td><input type="checkbox"/></td></tr> <tr><td>B8</td><td><input type="checkbox"/></td><td><input type="checkbox"/></td><td><input type="checkbox"/></td></tr> <tr><td>U1</td><td><input type="checkbox"/></td><td><input type="checkbox"/></td><td><input type="checkbox"/></td></tr> <tr><td>U2</td><td><input type="checkbox"/></td><td><input type="checkbox"/></td><td><input type="checkbox"/></td></tr> <tr><td>Y2</td><td><input type="checkbox"/></td><td><input type="checkbox"/></td><td><input type="checkbox"/></td></tr> <tr><td>Y1</td><td><input type="checkbox"/></td><td><input type="checkbox"/></td><td><input type="checkbox"/></td></tr> </table> <table border="1"> <tr><td>T1</td><td>○</td><td><input type="checkbox"/></td><td><input type="checkbox"/></td><td><input type="checkbox"/></td><td>○</td><td>T1</td></tr> <tr><td>T2</td><td>○</td><td><input type="checkbox"/></td><td><input type="checkbox"/></td><td><input type="checkbox"/></td><td>○</td><td>T2</td></tr> <tr><td>B7</td><td>○</td><td><input type="checkbox"/></td><td><input type="checkbox"/></td><td><input type="checkbox"/></td><td>○</td><td>B7</td></tr> <tr><td>B6</td><td>○</td><td><input type="checkbox"/></td><td><input type="checkbox"/></td><td><input type="checkbox"/></td><td>○</td><td>B6</td></tr> <tr><td>B5</td><td>○</td><td><input type="checkbox"/></td><td><input type="checkbox"/></td><td><input type="checkbox"/></td><td>○</td><td>B5</td></tr> <tr><td>B4</td><td>○</td><td><input type="checkbox"/></td><td><input type="checkbox"/></td><td><input type="checkbox"/></td><td>○</td><td>B4</td></tr> <tr><td>B2</td><td>○</td><td><input type="checkbox"/></td><td><input type="checkbox"/></td><td><input type="checkbox"/></td><td>○</td><td>B2</td></tr> <tr><td>B1</td><td>○</td><td><input type="checkbox"/></td><td><input type="checkbox"/></td><td><input type="checkbox"/></td><td>○</td><td>B1</td></tr> </table>	T1	<input type="checkbox"/>	<input type="checkbox"/>	<input type="checkbox"/>	T2	<input type="checkbox"/>	<input type="checkbox"/>	<input type="checkbox"/>	S1	<input type="checkbox"/>	<input type="checkbox"/>	<input type="checkbox"/>	S2	<input type="checkbox"/>	<input type="checkbox"/>	<input type="checkbox"/>	B1	<input type="checkbox"/>	<input type="checkbox"/>	<input type="checkbox"/>	B2	<input type="checkbox"/>	<input type="checkbox"/>	<input type="checkbox"/>	B3	<input type="checkbox"/>	<input type="checkbox"/>	<input type="checkbox"/>	B4	<input type="checkbox"/>	<input type="checkbox"/>	<input type="checkbox"/>	B5	<input type="checkbox"/>	<input type="checkbox"/>	<input type="checkbox"/>	B6	<input type="checkbox"/>	<input type="checkbox"/>	<input type="checkbox"/>	B7	<input type="checkbox"/>	<input type="checkbox"/>	<input type="checkbox"/>	B8	<input type="checkbox"/>	<input type="checkbox"/>	<input type="checkbox"/>	U1	<input type="checkbox"/>	<input type="checkbox"/>	<input type="checkbox"/>	U2	<input type="checkbox"/>	<input type="checkbox"/>	<input type="checkbox"/>	Y2	<input type="checkbox"/>	<input type="checkbox"/>	<input type="checkbox"/>	Y1	<input type="checkbox"/>	<input type="checkbox"/>	<input type="checkbox"/>	T1	○	<input type="checkbox"/>	<input type="checkbox"/>	<input type="checkbox"/>	○	T1	T2	○	<input type="checkbox"/>	<input type="checkbox"/>	<input type="checkbox"/>	○	T2	B7	○	<input type="checkbox"/>	<input type="checkbox"/>	<input type="checkbox"/>	○	B7	B6	○	<input type="checkbox"/>	<input type="checkbox"/>	<input type="checkbox"/>	○	B6	B5	○	<input type="checkbox"/>	<input type="checkbox"/>	<input type="checkbox"/>	○	B5	B4	○	<input type="checkbox"/>	<input type="checkbox"/>	<input type="checkbox"/>	○	B4	B2	○	<input type="checkbox"/>	<input type="checkbox"/>	<input type="checkbox"/>	○	B2	B1	○	<input type="checkbox"/>	<input type="checkbox"/>	<input type="checkbox"/>	○	B1
T1	<input type="checkbox"/>			<input type="checkbox"/>	<input type="checkbox"/>																																																																																																																						
T2	<input type="checkbox"/>	<input type="checkbox"/>		<input type="checkbox"/>																																																																																																																							
S1	<input type="checkbox"/>	<input type="checkbox"/>		<input type="checkbox"/>																																																																																																																							
S2	<input type="checkbox"/>	<input type="checkbox"/>		<input type="checkbox"/>																																																																																																																							
B1	<input type="checkbox"/>	<input type="checkbox"/>		<input type="checkbox"/>																																																																																																																							
B2	<input type="checkbox"/>	<input type="checkbox"/>		<input type="checkbox"/>																																																																																																																							
B3	<input type="checkbox"/>	<input type="checkbox"/>		<input type="checkbox"/>																																																																																																																							
B4	<input type="checkbox"/>	<input type="checkbox"/>		<input type="checkbox"/>																																																																																																																							
B5	<input type="checkbox"/>	<input type="checkbox"/>		<input type="checkbox"/>																																																																																																																							
B6	<input type="checkbox"/>	<input type="checkbox"/>		<input type="checkbox"/>																																																																																																																							
B7	<input type="checkbox"/>	<input type="checkbox"/>		<input type="checkbox"/>																																																																																																																							
B8	<input type="checkbox"/>	<input type="checkbox"/>		<input type="checkbox"/>																																																																																																																							
U1	<input type="checkbox"/>	<input type="checkbox"/>		<input type="checkbox"/>																																																																																																																							
U2	<input type="checkbox"/>	<input type="checkbox"/>		<input type="checkbox"/>																																																																																																																							
Y2	<input type="checkbox"/>	<input type="checkbox"/>		<input type="checkbox"/>																																																																																																																							
Y1	<input type="checkbox"/>	<input type="checkbox"/>	<input type="checkbox"/>																																																																																																																								
T1	○	<input type="checkbox"/>	<input type="checkbox"/>	<input type="checkbox"/>	○	T1																																																																																																																					
T2	○	<input type="checkbox"/>	<input type="checkbox"/>	<input type="checkbox"/>	○	T2																																																																																																																					
B7	○	<input type="checkbox"/>	<input type="checkbox"/>	<input type="checkbox"/>	○	B7																																																																																																																					
B6	○	<input type="checkbox"/>	<input type="checkbox"/>	<input type="checkbox"/>	○	B6																																																																																																																					
B5	○	<input type="checkbox"/>	<input type="checkbox"/>	<input type="checkbox"/>	○	B5																																																																																																																					
B4	○	<input type="checkbox"/>	<input type="checkbox"/>	<input type="checkbox"/>	○	B4																																																																																																																					
B2	○	<input type="checkbox"/>	<input type="checkbox"/>	<input type="checkbox"/>	○	B2																																																																																																																					
B1	○	<input type="checkbox"/>	<input type="checkbox"/>	<input type="checkbox"/>	○	B1																																																																																																																					
T2	-KTY																																																																																																																										
S1		Thermostat (NC contact)																																																																																																																									
S2																																																																																																																											
B1	+ Ref	Transformer winding (reference winding)																																																																																																																									
B2	- Ref																																																																																																																										
B3	+ VCC ETS	Supply: electronic nameplate <sup>1)</sup>																																																																																																																									
B4	+ Cos	Stator winding cosine																																																																																																																									
B5	- Cos																																																																																																																										
B6	+ Sin	Stator winding sine																																																																																																																									
B7	- Sin																																																																																																																										
B8		Not assigned																																																																																																																									
U1	L1	Separate fan																																																																																																																									
U2	N																																																																																																																										
Y2 <sup>2)</sup> / BD2	-	Holding brake																																																																																																																									
Y1 <sup>2)</sup> / BD1	+																																																																																																																										

1) Only for versions with electronic nameplate ETS.

2) When using the version "with an integrated rectifier" the voltage supply for the brake is applied directly to the rectifier. The terminals Y1 and Y2 are not provided in this version.

### 5.4.2 Resolver connection

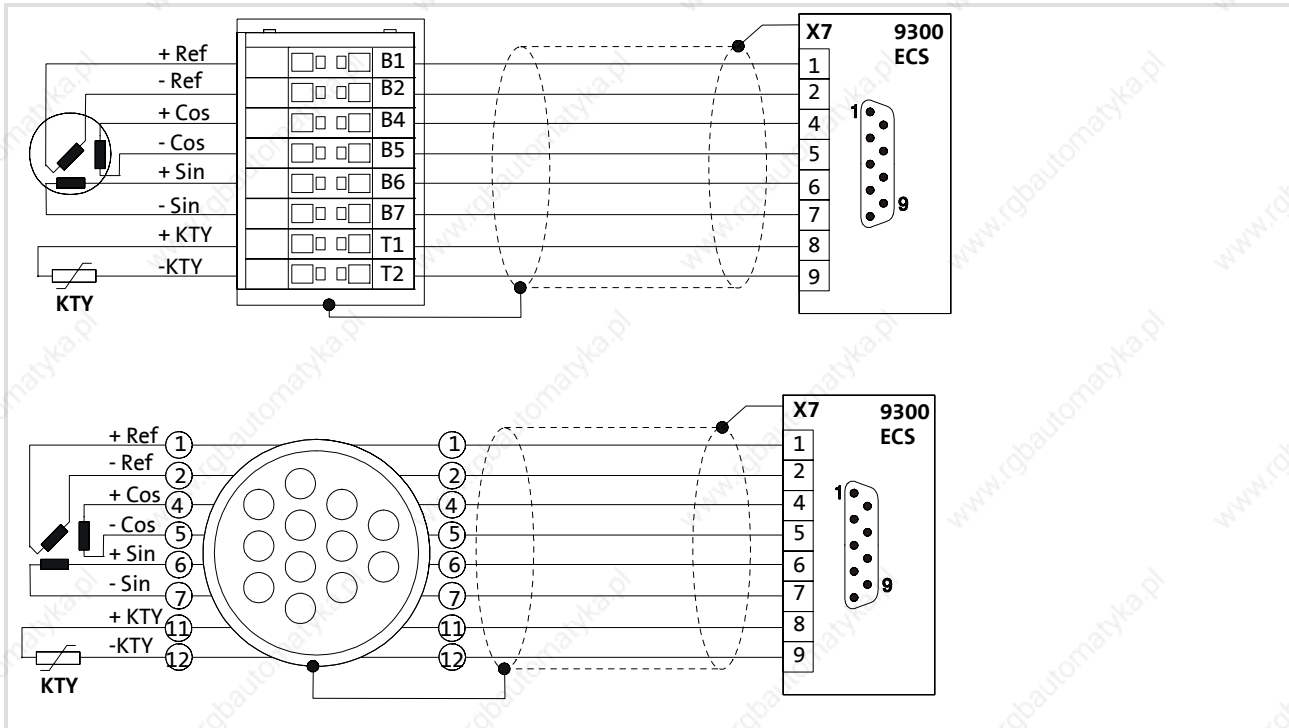

### 5.4.3 Sin-Cos absolute value encoder

Connector (external view of poles)

Pin		Meaning
1	B	Track B / + SIN
2	$\bar{A}$	Track A inverse / - COS
3	A	Track A / + COS
4	+ 5 V	Supply + 5 V / + 8 V
5	GND	Earth
6	$\bar{Z}$	Zero track inverse / - RS485
7	Z	Zero track / + RS485
8		Not assigned
9	$\bar{B}$	Track B inverse / - SIN
10		Not assigned
11	+ KTY	Temperature sensor KTY
12	-KTY	

Size 1.0; M23

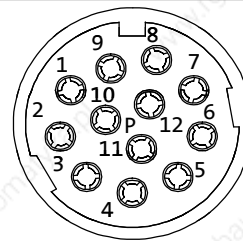

20° coded

# Electrical installation

## Feedback connection

### Connection incremental encoder / SinCos encoder

Terminal box		
Terminal		Meaning
T1	+ KTY	Temperature sensor KTY
T2	-KTY	
B1	+ 5 V	Supply + 5 V / + 8 V Earth
B2	GND	
B3	A	Track A / + COS
B4	$\bar{A}$	Track A inverse / - COS
B5	B	Track B / + SIN
B6	$\bar{B}$	Track B inverse / - SIN
B7	Z	Zero track inverse / - RS485 Zero track / + RS485
B8	$\bar{Z}$	
B10	Shield for housing	Shield for incremental encoder
U1	L1+	Separate fan
U2	N	

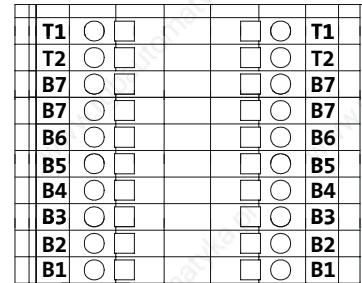
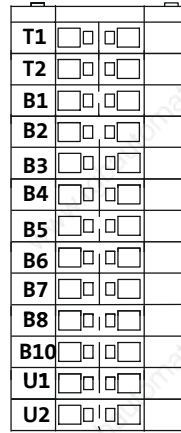

#### 5.4.4 Connection incremental encoder / SinCos encoder

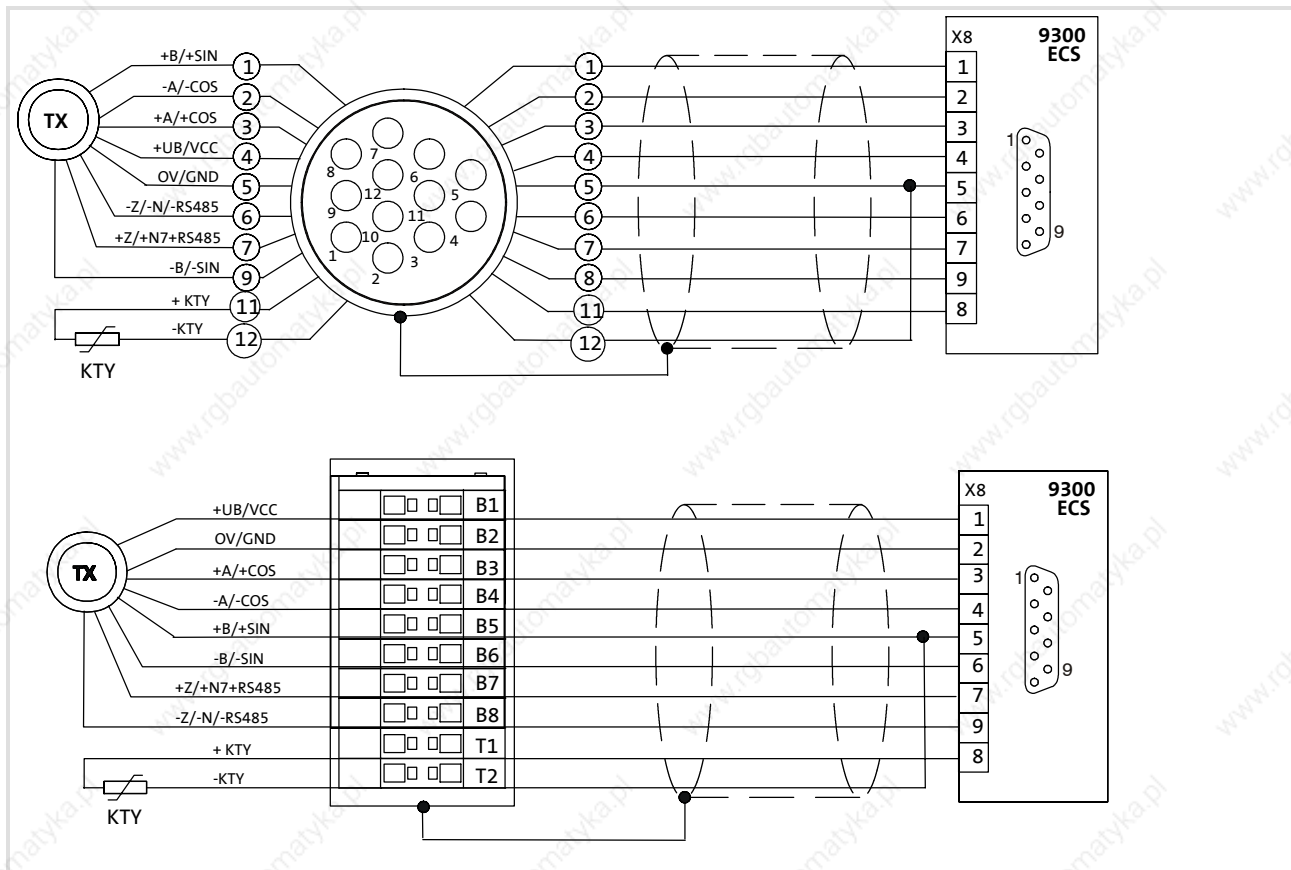

5.4.5 Sin-Cos absolute value encoder with EnDat interface

MCS connector (external view of poles)			Size 1.0; M23
Pin	Meaning		
1	UP sensor	Supply UP sensor	
2		Not assigned	
3			
4	0V sensor	Supply 0V sensor	
5	+ KTY	Temperature sensor KTY	
6	-KTY		
7	+ 5 V	Supply +5V / +VCC ETS 1)	
8	Clock pulse	Clock pulse EnDat interface	
9	Clock pulse	Clock pulse inverse EnDat interface	
10	GNG	Supply 0V / earth	
11	Shield	Shield for housing of encoder	
12	B	Track B / + SIN	
13	$\bar{B}$	Track B inverse / - SIN	
14	Data	Data EnDat interface	
15	A	Track A / + COS	
16	$\bar{A}$	Track A inverse / - COS	
17	$\bar{Data}$	Data inverse EnDat interface	

1) Only for versions with electronic nameplate ETS.

Terminal box				
Terminal	Meaning			
T1	+ KTY	Temperature sensor KTY	T1	<input type="checkbox"/>
T2	-KTY		T2	<input type="checkbox"/>
B1	+5V	Supply +5V / +VCC ETS 1)	B1	<input type="checkbox"/>
B2	GNG	Supply 0V / earth	B2	<input type="checkbox"/>
B3	A	Track A / + COS	B3	<input type="checkbox"/>
B4	$\bar{A}$	Track A inverse / - COS	B4	<input type="checkbox"/>
B5	B	Track B / + SIN	B5	<input type="checkbox"/>
B6	$\bar{B}$	Track B inverse / - SIN	B6	<input type="checkbox"/>
B7	Data	Data EnDat interface	B7	<input type="checkbox"/>
B8	Data	Data inverse EnDat interface	B8	<input type="checkbox"/>
B20	Clock pulse	Clock pulse EnDat interface	B10	<input type="checkbox"/>
B21	Clock pulse	Clock pulse inverse EnDat interface	B23	<input type="checkbox"/>
B22	UP sensor	Supply UP sensor	B20	<input type="checkbox"/>
B23	0V sensor	Supply 0V sensor	B24	<input type="checkbox"/>
B24	Shield	Shielding for housing of encoder	B21	<input type="checkbox"/>
B25		Not assigned	B25	<input type="checkbox"/>
U1	L1+	Separate fan	B22	<input type="checkbox"/>
U2	N		U1	<input type="checkbox"/>
			U2	<input type="checkbox"/>

	B20	<input type="checkbox"/>		<input type="checkbox"/>	B20
	B21	<input type="checkbox"/>		<input type="checkbox"/>	B21
	B22	<input type="checkbox"/>		<input type="checkbox"/>	B22
	B23	<input type="checkbox"/>		<input type="checkbox"/>	B23
	B24	<input type="checkbox"/>		<input type="checkbox"/>	B24
	B25	<input type="checkbox"/>		<input type="checkbox"/>	B25
	T2	<input type="checkbox"/>		<input type="checkbox"/>	T2
	T1	<input type="checkbox"/>		<input type="checkbox"/>	T1
	B8	<input type="checkbox"/>		<input type="checkbox"/>	B8
	B7	<input type="checkbox"/>		<input type="checkbox"/>	B7
	B6	<input type="checkbox"/>		<input type="checkbox"/>	B6
	B5	<input type="checkbox"/>		<input type="checkbox"/>	B5
	B4	<input type="checkbox"/>		<input type="checkbox"/>	B4
	B3	<input type="checkbox"/>		<input type="checkbox"/>	B3
	B2	<input type="checkbox"/>		<input type="checkbox"/>	B2
	B1	<input type="checkbox"/>		<input type="checkbox"/>	B1

1) Only for versions with electronic nameplate ETS.

## 6 Commissioning

### Before switching on

## 6 Commissioning

### 6.1 Before switching on

Before the initial commissioning, before commissioning after an extended standstill time or before commissioning after an overhaul of the motor, you must check the following:

- ▶ Are all screwed connections of the mechanical and electrical parts firmly tightened?
- ▶ Is the unrestricted cooling-air inlet and outlet ensured?
- ▶ Are the protective devices against overheating (thermal sensor evaluation) effective?
- ▶ Is the drive controller correctly parameterised for the motor?  
( Drive controller operating instructions)
- ▶ Are the electrical connections o.k.?
- ▶ Does the motor connection have the correct phase sequence?
- ▶ Are rotating parts and surfaces, which can become very hot, protected against touching?
- ▶ Is the permanent lubrication connected?



#### **Danger!**

Built-in brakes are not fail-safe brakes!

## 6.2 Parameter setting



### Stop!

The integrated thermal sensor does not prevent overload under all conditions!  
At commissioning, reduce the maximum current, e.g. to the rated current of the motor!

Perform function block interconnection (servo inverter 9300) or  $I^2xt$  monitoring (servo inverter ECS) with disconnection after several seconds of operation with  $I > I_N$ , particularly in case of danger of blocking.

- ▶ Commission the drive system according to the operating instructions of the drive controller.
  - Entering motor data, parameter setting via Global Drive Control
  - Parameter setting of motor temperature detection (is carried out automatically with parameter setting via GDC)
  - Specifying feedback system for speed and position control
  - Selecting the operating mode (control structure)
  - Entering machine data
  - Optimising the drive behaviour, if necessary (optimisation of current, speed, field and field-weakening control; observe the notes below!).



### Stop!

The parameter data that are set via GDC are used as default setting and must be optimised specific to each application!

### 6.2.1 Servo controller 9300

The input variable of the current controller is normalised to the maximum device current  $I_{\max. \text{ device}}$ . This allows the maximum device current to directly influence the current controller gain  $V_p$ . If a smaller or larger device is used after the current controller adjustment, the current controller must be adjusted again or the  $V_p$  must be matched.

The input and output variables of the speed controller are normalised to the maximum current  $I_{\max.}$  (C0022) and the maximum speed  $n_{\max.}$  (C0011). This allows C0022 and C0011 to directly influence the gain of the speed controller  $V_{pn}$ .

- ▶ The following applies to the servo controller 9300:
  - $V_p$  proportional  $I_{\max. \text{ device}}$
  - $V_{pn}$  proportional  $n_{\max.}$  (C0011)
  - $V_{pn}$  proportional  $1/I_{\max.}$  (C0022)

## 6 Commissioning

### Parameter setting Servo controller ECS

#### 6.2.2 Servo controller ECS

The input and output variables of the speed controller are normalised to the maximum current  $I_{\max}$ . (C0022) and the maximum speed  $n_{\max}$ . (C0011). This allows C0022 and C0011 to directly influence the gain of the speed controller  $V_{pn}$ .

- ▶ The following applies to the servo controller ECS:
  - $V_{pn}$  proportional  $n_{\max}$ . (C0011)
  - $V_{pn}$  proportional  $1/I_{\max}$ . (C0022)

#### 6.2.3 Parameter setting of motor temperature detection



##### Stop!

- ▶ Integrated overload protection does not prevent overloading under all conditions!
- ▶ Limit maximum current to required value!

The motor winding temperature is monitored by temperature sensors.

#### 6.2.4 Parameterisation of the temperature sensor 9300 / ECS

- ▶ MCS06
  - C1190 = 0 (Standard, KTY83-110)
- ▶ MCS09/12/14/19
  - C1190 = 1 (Characteristic, KTY83-110 + PTC150)
  - C1191/1 = 30
  - C1191/2 = 145
  - C1192/1 = 1180
  - C1192/2 = 2460
- ▶ MDXKX, MDFQA, MDXMA
  - C1190 = 0

6.3 Function block interconnection servo inverter 9300



**Stop!**

Perform function block interconnection (servo inverter 9300) or I<sup>2</sup>t monitoring (servo inverter ECS) with disconnection after several seconds of operation with I > I<sub>N</sub>, particularly in case of danger of blocking.

Example of function block interconnection for MCS06F41

$$I_0 = 1.5A, C0022 (I_{max.}) = 5.3A \Rightarrow C0472/1 = 8.83\%$$

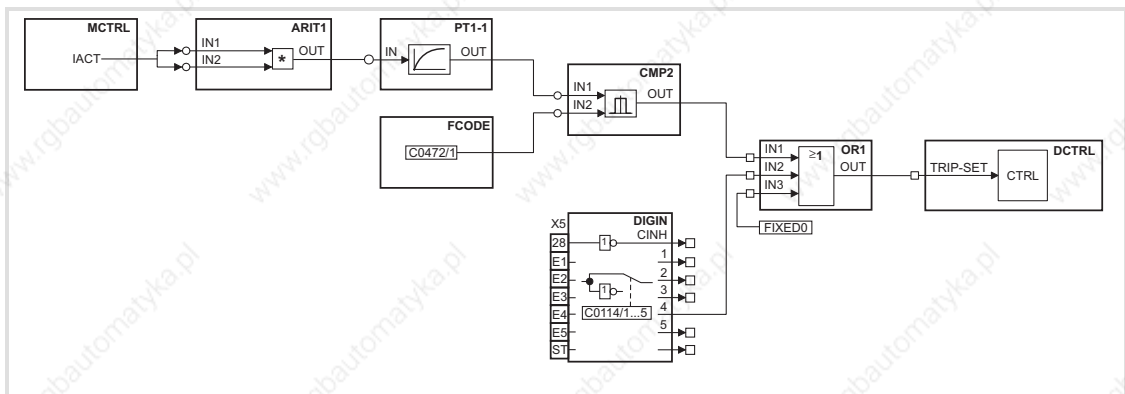

Display:

- Input value of PT1: C0642
- Output value of PT1: C0689/1
- Limit value: C0689/2

**Calculation of limit value (FCODE 0472/1):**

$$FCODE472/1 = (I_0 \cdot \frac{1}{I_{max}} \cdot 1.05)^2 \cdot 100$$

I <sub>0</sub> [A]	Standstill current of motor
I <sub>max</sub> [A]	Maximum current set in code C0022

Factor 1.05: for consideration of manufacturing tolerances and reaching the standstill torque; disconnection at I > 1.05 \* I<sub>0</sub>

**Time constant PT1: C0640 (currently 30 s)**

## 6.4 Parameterisation of function block interconnection

Basis for this function block interconnection is the configuration 1000 or 1010 (speed control).

Parameter setting arithmetic block ARIT1				
Code	Setting	Signal	Assignment	Meaning
C0338	3	ARIT1 FUNCT	OUT = IN1*IN2	Multiply input signals
C0339/1	5004	ARIT1-IN1	MCTRL-IACT	Input signal = motor current
C0339/2	5004	ARIT1-IN2	MCTRL-IACT	
Parameter setting PT1 element PT1-1				
Code	Setting	Signal	Assignment	Meaning
C0640	30 s	DELAY T	Time constant = 30 s	
C0641	5500	IN	ARIT1-OUT	Input signal = output from ARIT1
Parameter setting for the limit value in FCODE472/1				
Code	Setting			Meaning
C0472/1	$FCODE472/1 = \left( \frac{I_0}{I_{max}} \cdot 1.05 \right)^2 \cdot 100 \%$			The factor 1.05 is a starting value for commissioning. This value may need to be adjusted to achieve the standstill torques and maximum torques.
	$I_0$ [A]	Standstill current of the motor		
	$I_{max}$ [A]	Maximum current from C0022		
Parameter setting comparator CMP2				
Code	Setting	Signal	Assignment	Meaning
C0685	5	FUNCTION	$ In1  >  In2 $	Compare $I^2xt$ value with limit value
C0686	1.00 %	HYSTERESIS	Hysteresis = 1 %	Hysteresis of the output signal
C0687	1.00 %	WINDOW	Window = 1 %	Window for the output signal
C0688/1	5900	IN1	PT1-1-OUT	Input signal 1 = output from PT1-1 ( $I^2xt$ value)
C0688/2	19521	IN2	FCODE-0472/1	Input signal 2 = FCODE472/1 (limit value)
Parameter setting OR logic OR1				
Code	Setting	Signal	Assignment	Meaning
C0830/1	10665	IN1	CMP2-OUT	Input signal 1 = output from CMP2
C0830/2	54	IN2	DIGIN4	Input signal 2 = digital input E4
C0830/3	1000	IN3	FIXED0	Input signal 3 = "logical 0"
Parameter setting for the error input in the device control DCTRL				
Code	Setting	Signal	Assignment	Meaning
C0871	10550	TRIP-SET	OR1-OUT	TRIP is triggered if the $I^2xt$ monitoring has tripped or there is an external fault on E4

**Enter function blocks used in the processing table**

Code	Setting	Function block
C0465/32	5500	ARIT1
C0465/34	5900	PT1-1
C0465/35	10655	CMP2
C0465/36	10550	OR1

**6.5****Functional test**

- ▶ Check all functions of the drive after commissioning:
  - Direction of rotation of the motor  
If the motor does not rotate in the correct direction, exchange two phases.
  - Torque behaviour and current consumption
  - Function of the feedback system
- ▶ In case of malfunctions or faults:  Ch. 8.

## 7 During operation

### 7 During operation

Perform regular inspections during operation. Check the drives approx. every 50 operating hours. Pay particular attention to:

- ▶ Unusual noises
- ▶ Extremely hot surfaces (temperatures of 140°C can occur during normal operation).
- ▶ Oil spots on drive or leakage
- ▶ Irregular running
- ▶ Increased vibration
- ▶ Loose fixing elements
- ▶ Condition of electrical cables
- ▶ Impeded heat dissipation
  - Deposits on the drive system and in the cooling channels

In case of irregularities or faults:  Ch. 8.

## 8 Troubleshooting and fault elimination

If faults occur during the operation of the drive system:

- ▶ First check the possible causes of malfunction according to the following table.
- ▶ Also observe the corresponding chapters in the operating instructions to the other components of the drive system.

If the fault cannot be remedied using one of the listed measures, please contact the Lenze Service.



### Danger!

- ▶ Perform all work at the drive system only in the deenergised state!
- ▶ Hot motor surfaces, up to 140 °C. Observe cooling times!
- ▶ Remove the load from the motors or secure loads acting upon the drive!

Fault	Cause	Remedy
Motor too hot	Motor is designed for star connection but is connected in delta	Correct connection
Measurement required; permissible surface temperatures: <ul style="list-style-type: none"> <li>● non-ventilated motors up to 140 °C</li> <li>● forced or self-ventilated motors up to 110 °C</li> </ul>	Mains voltage is more than 10 % higher or lower than the rated motor voltage. A higher voltage is extremely unfavourable for motors with many poles as the idling current of these motors almost reaches the rated current, even at normal current.	Ensure appropriate mains voltage
	Insufficient cooling air, blocked air ducts.	Ensure unimpeded circulation of cooling air
	Prewarmed cooling air	Ensure a sufficient supply of fresh cooling air
	Overload, with normal mains voltage the current is too high and the speed too low	Use larger drive (determined by power measurement)
	Rated operating mode exceeded (S1 to S8 DIN 57530)	Adjust rated operating mode to the specified operating conditions. Determination of correct drive by expert or Lenze customer service
	Loose contact in supply cable (temporary single-phase operation!)	Tighten loose contact
	Fuse blown (single-phasing!)	Replace fuse

## 8 Troubleshooting and fault elimination

Fault	Cause	Remedy
Motor does not start	Voltage supply interrupted	<ul style="list-style-type: none"> <li>● Check error message at drive controller</li> <li>● Check electrical connection (☐ Ch. 5)</li> </ul>
	Controller inhibited	<ul style="list-style-type: none"> <li>● Check display at drive controller</li> <li>● Check controller enable</li> </ul>
	Fuse is blown	Replace fuse
	Motor protection responded	Check motor protection for correct setting and adjust it
	Motor contactor does not engage, fault in the control	Check control of motor contactor and remove fault
	Resolver cable is interrupted	<ul style="list-style-type: none"> <li>● Check error message at drive controller</li> <li>● Check resolver cable</li> </ul>
	Brake does not release	Check electrical connection Check air gap (see Brake operating instructions) Check continuity of magnetic coil
	Drive is blocked	Check components for easy movement, remove foreign bodies if necessary
	Motor cable polarity is reversed	Check electrical connection
Motor stops suddenly and does not start again	<ul style="list-style-type: none"> <li>● Polarity reversal of motor cable</li> <li>or</li> <li>● polarity reversal of resolver</li> </ul>	<ul style="list-style-type: none"> <li>● Connect the phases at the motor cable connection correctly and</li> <li>● connect the encoder correctly</li> </ul>
	Overtemperature protector switch is activated	<ul style="list-style-type: none"> <li>● Let motor cool down</li> <li>– Reduce load caused by longer acceleration times</li> </ul>
	Overload monitoring of the inverter is activated	<ul style="list-style-type: none"> <li>● Check settings on controller</li> <li>● Reduce load caused by longer acceleration times</li> </ul>
Wrong direction of rotation of the motor, correct display at controller	Reversed motor cable and resolver cable	<ul style="list-style-type: none"> <li>● Swapping two phases of the motor cable</li> <li>and</li> <li>● +COS/-COS connections of the resolver connection</li> </ul>
Motor rotates normally but does not reach the expected torque	Motor cable cyclically interchanged	Connect the phases at the motor cable connection correctly
Motor rotates uncontrolled in one direction at maximum speed	Motor cable is cyclically interchanged or polarity reversal of resolver cable, e.g. connections +Ref/-Ref	Check motor connection for resolver connection
Motor rotates slowly in one direction and cannot be influenced by the controller (only in the case of the asynchronous motors MDXKA, MDFQA, MDXMA)	Polarity reversal of motor or resolver cable	<ul style="list-style-type: none"> <li>● Swap two phases of the motor cable</li> <li>or</li> <li>● the +COS/-COS connections of the resolver</li> </ul>
Motor does not rotate, gearbox output is not running	Defective wheel-hub connection	Check the connection, replace the featherkey, if necessary, repair by the manufacturer
	Toothing worn out	Repair by the manufacturer
Uneven running	Insufficient shielding of motor or resolver cable	Check shielding and earthing (☐ Ch. LEERER MERKER)
	Drive controller gain too large	Adjust the gains of the controllers (see Drive controller operating instructions)
Vibrations	Insufficiently balanced coupling elements or machine	Rebalance
	Inadequate alignment of drive train	Realign machine, if necessary, check foundation
	Loose fixing screws	Check screwed connections and tighten if necessary
Running noises	Foreign bodies inside the motor	Repair by manufacturer, if necessary
	Bearing damage, spindle damage	Repair by manufacturer, if necessary
Surface temperature > 140 °C	Overload of drive	<ul style="list-style-type: none"> <li>● Check overload and reduce through longer acceleration times, if necessary</li> <li>● Check winding temperature (☐ Ch. 9.2.2)</li> </ul>
	Heat removal restricted due to deposit build-up	Clean surface and cooling ribs of the drives

## 9 Maintenance/repair

### 9.1 Maintenance intervals

- ▶ In general, the motors are maintenance-free.
- ▶ Wear only occurs on the bearings and shaft sealing rings.
  - Check bearings for running noise (at latest after approx. 15000 h).
  - Check shaft sealing ring (at latest after approx. 2500 h): oil leakage on the motor between the flange and the housing? If necessary, replace after 2500-3000 operating hours.
- ▶ To avoid overheating, remove deposits from the drives at regular intervals.
- ▶ It is recommended to regularly perform an inspection after approx. 50 operating hours. This allows for early identification and elimination of irregularities or faults.

### 9.2 Maintenance operations



#### Stop!

- ▶ Ensure that no foreign particles can gain access to the inside the motor!
- ▶ Ensure that the drive system is deenergised before working on it!
- ▶ Disconnect drives from the mains!
- ▶ Hot motor surfaces, up to 140 °C. Observe cooling times!
- ▶ Unload motor or secure loads that are applied to the drive!
- ▶ Never disconnect from the mains when energised!

**9.2.1 Adjustment of the resolver using synchronous servo motors/rotor position adjustment**

The factory settings of the Lenze resolver ensure trouble-free operation without adjustment at the controller.

If the resolver is in the wrong position, e.g. after working on the motor, it will have to be realigned or the rotor will have to be adjusted via the controller.

▶ For the **rotor adjustment**, the motor must be free of load and able to rotate with the controller (📖 operating instructions of controller). The rotor adjustment is saved in the controller and only applies for the respective motor-controller combination.

▶ **Resolver adjustment**

1. If necessary, release the brake and free end of motor shaft.
2. Connect the resolver to the drive controller and determine current rotor position (📖 Operating instructions for drive controller).
3. Allow DC current ( $< I_N$  of motor) to flow from phase V (positive connection) to phase W (negative connection), phase U is without current.
4. Turn the resolver stator so that the controller displays the rotor position "0".
5. Fasten the resolver stator in this position.

**9.2.2 Temperature control for servo motors**

You must determine the actual winding temperature at a surface temperature  $> 140\text{ °C}$ :

- ▶ Measuring method: 4-phase resistance measurement at motor power terminal
- ▶ The resistance measurement must be performed as quickly as possible after switching off and stopping the servo motor.

### Procedure

1. Inhibit controller.
2. Disconnect power connection; in the case of terminal box design, disconnect power supply between inverter and motor.
3. Measure the resistance between the following contacts or terminals:
  - Connector size 1.0; M23:  
pins U↔V, V↔W, W↔U
  - Connector size 1.5; M40:  
pins 4↔5, 5↔6 and 6↔4
  - Terminal box:  
terminals 1↔2, 2↔3 and 3↔1 and U↔V, V↔W, W↔U
4. The mean value calculated from the three measured values corresponds to twice the phase resistance (star connection).
  - Use the mean value as  $R_1$  and  $R_0$  in the following equation to calculate the winding temperature  $\vartheta_1$ :

$\vartheta_1 [^{\circ}\text{C}] = \frac{R_1 \cdot 255}{R_0} - 235$	$\vartheta_1$	Winding temperature during operation
	$R_1$	Winding resistance at operating temperature
	$R_0$	Winding resistance at 20°C

### 9.3

#### Repair

- ▶ It is recommended to have all repairs performed by Lenze Service.
- ▶ Delivery of spare parts is available upon request.

**10 Notes**

**10 Notes**





# Lenze worldwide

## Lenze AG

Postfach 10 13 52  
D-31763 Hameln  
Telefon +49 (0)51 54 / 82-0  
Telefax +49 (0)51 54 / 82-28 00  
E-Mail: Lenze@Lenze.de  
Internet: www.Lenze.com

## Lenze Drive Systems GmbH

Postfach 10 13 52  
D-31763 Hameln  
Telefon +49 (0)51 54 / 82-0  
Telefax +49 (0)51 54 / 82-2800

## Lenze GmbH & Co KG Anlagenbau

Buchenweg 1  
D-31855 Aerenzen  
Telefon +49 (0)51 54 / 82-0  
Telefax +49 (0)51 54 / 82-21 00

## Lenze GmbH & Co KG Kleinantriebe

Hans-Lenze-Straße 1  
D-32699 Extertal  
Telefon +49 (0)51 54 / 82-0  
Telefax +49 (0)51 54 / 82-14 85

## Lenze Service GmbH

Breslauer Straße 3  
D-32699 Extertal

## Mechanical Drives

Telefon +49 (0)51 54 / 82-1626  
Telefax +49 (0)51 54 / 82-1396

## Electronic Drives

Telefon +49 (0)51 54 / 82-11 11  
Telefax +49 (0)51 54 / 82-11 12

## Service Helpline

+49 (0)180 5 20 24 26

## Lenze Verbindungstechnik GmbH

IpF-Landesstraße 1  
A-4481 ASTEN  
Phone +43 (0)72 24 / 21 1-0  
Telefax +43 (0)72 24 / 21 19 98

## Lenze Deto Drive Systems GmbH & Co KG

Gewerbepark Süd 11  
A-6330 Kufstein  
Telefon +43 (0)53 72 / 653 15-200  
Telefax +43 (0)53 72 / 653 15-299

## LS Automation GmbH & Co KG

Jakob-Stadler-Platz 11  
D-78467 Konstanz  
Telefon +49 (0)75 31 / 9 42 19-0  
Telefax +49 (0)75 31 / 9 42 19 20

## encoway GmbH

Universitätsallee 21-23  
D-28359 Bremen  
Telefon +49 (0)421 / 2 46 77-0  
Telefax +49 (0)421 / 2 46 77-10

## Deutschland Germany

### Lenze Vertrieb GmbH

Ludwig-Erhard-Straße 52-56  
D-72760 Reutlingen  
Telefon +49 (0)71 21 / 9 39 39-0  
Telefax +49 (0)71 21 / 9 39 39-29

### Region Nord

Domenpark 1  
31840 Hessisch Oldendorf  
Telefon (0 51 52) 90 36-0  
Telefax (0 51 52) 90 36-33/44/55

### Region West

Postfach 10 12 20  
47497 Neukirchen-Vluyn  
Kelvinstraße 7  
47506 Neukirchen-Vluyn  
Telefon (0 28 45) 95 93-0  
Telefax (0 28 45) 95 93 93

### Region Mitte/Ost

Postfach 1463  
35724 Herborm  
Austraße 81  
35745 Herborm  
Telefon (0 27 72) 95 94-0  
Telefax (0 27 72) 5 30 79

### Region Südwest

Postfach 14 33  
71304 Waiblingen  
Schänzle 8  
71332 Waiblingen  
Telefon (0 71 51) 9 59 81 - 0  
Telefax (0 71 51) 9 59 81 50

### Region Süd

Fraunhoferstraße 16  
82132 Martinsried  
Telefon (0 89) 89 56 14-0  
Telefax (0 89) 89 56 14 14

## weltweit worldwide

### ALGERIA

see FRANCE

### ARGENTINA

E.R.H.S.A.  
Girardot 1368, 1427 BUENOS AIRES  
Phone +54 (0)11 / 45 54 32 32  
Telefax +54 (0)11 / 45 52 36 11

### AUSTRALIA

FCR Motion Technology Pty. Ltd.  
Unit 6, Automation Place  
38-40 Little Boundary Rd.  
LAVERTON NORTH, Vic. 3026  
Phone +61 (3) 9362 8800  
Telefax +61 (3) 9314 3744

### AUSTRIA

Lenze Antriebstechnik GmbH  
IpF-Landesstraße 1  
4481 ASTEN  
Phone +43 (0)7224 / 21 0-0  
Telefax +43 (0)7224 / 21 09 99

Office Dornbirn:  
Lustenauer Straße 64  
6850 DORNBIERN  
Phone +43 (0)5572 / 26 789-0  
Telefax +43 (0)5572 / 26 789-66

Office Wr. Neudorf:  
Triester Straße 14/109  
2351 WR. NEUDORF  
Phone +43 (0)2236 / 2 53 33-0  
Telefax +43 (0)2236 / 2 53 33-66

Office Graz:  
Seering 8  
8141 UNTERPREMSTÄTTEN  
Phone +43 (0)3135 / 56 900-0  
Telefax +43 (0)3135 / 56 900 999

Lenze Verbindungstechnik GmbH  
IpF-Landesstraße 1  
4481 ASTEN  
Phone +43 (0)7224 / 21 1-0  
Telefax +43 (0)7224 / 21 19 98

Lenze Anlagentechnik GmbH  
Mühlenstraße 3  
4470 ENNS  
Phone +43 (0)7223 / 886-0  
Telefax +43 (0)7223 / 886-997

### BELGIUM

Lenze b.v.b.a  
Noorderlaan 133, bus 15  
2030 ANTWERPEN  
Phone +32 (0)3 / 54 26 20 0  
Telefax +32 (0)3 / 54 13 75 4

### BOSNIA-HERZEGOVINA

see AUSTRIA

### BRAZIL

AC Control Ltda  
Rua Gustavo da Silveira 1199  
Vila Sta. Catarina  
SÃO PAULO - S.P.  
04376-000  
Phone +55 (11) 55 64 65 79 ramal: 214  
Telefax +55 (11) 56 79 75 10

### BULGARIA

see MACEDONIA

### CANADA

see USA

### CHILE

Sargent S.A.  
Technica Thomas C. Sargent  
S.A.C.é.I., Casilla 166-D  
SANTIAGO DE CHILE  
Phone +56 (0)2 / 51 03 000  
Telefax +56 (0)2 / 69 83 989

### CHINA

Lenze Mechatronic Drives (Shanghai)  
Co. Ltd., Section B, 50# building,  
No.199 North Ri Ying Road,  
Waigaoqiao Free Trade Zone  
SHANGHAI, 200131  
Phone +86-21-5046 0848  
Telefax +86-21-5046 0850

Beijing Office  
Rm. 401, Huaxin Mansion  
No. 33 An Ding Road  
Chaoyang District  
BEIJING 100029  
Phone +86-10-6441 1470  
Telefax +86-10-6441 1467

### CROATIA

Lenze Antriebstechnik GmbH  
Predstavništvo Zagreb  
Ulica Grada Gospića 3  
HR-1000 ZAGREB  
Phone +385-1-2 49 80 56  
Telefax +385-1-2 49 80 57

### CZECH REPUBLIC

Lenze, s.r.o.  
Central Trade Park D1  
396 01 HUMPOLEC  
Phone +420 565 507-111  
Telefax +420 565 507-399

Büro Červený Kostelec:  
17. listopadu 510  
549 41 ČERVENÝ KOSTELEČ  
Phone +420 491 467-111  
Telefax +420 491 467-166

### DENMARK

Lenze A/S  
Vallensbækvej 18A  
2605 BRØNDBY  
Phone +45 / 46 96 66 66  
Telefax +45 / 46 96 66 60  
24 stunde service +45 / 40 93 04 11

Buero Jylland:  
Lenze A/S  
Langhøjvej 1  
8381 TILST  
Phone +45 / 46 96 66 66  
Telefax +45 / 46 96 66 80

### EGYPT

WADI Co. for technologies  
and development  
P.O.Box 209, new center Ramses  
11794 CAIRO, Egypt  
11 Syria St., Mohandessin  
GIZA, Egypt  
Phone +20 (2) 347 6842  
Telefax +20 (2) 347 6843

### ESTONIA

see FINLAND

### FINLAND

Lenze Drives  
Rykmentintie 2 b  
20810 TURKU  
Phone +358 2 2748 180  
Telefax +358 2 2748 189

### FRANCE

Lenze S.A.  
**Siege**  
Z.A. de Chanteloup  
Rue Albert Einstein  
93603 AULNAY-SOUS-BOIS CEDEX

### Services Commerciaux

Tel. 0 825 086 036  
Fax 0 825 086 346

### Centre de formation

E-Mail : semin.sidonie@lenze.fr

### Questions générales / Documentation

E-Mail : info@lenze.fr

### Service Après-vente / assistance en ligne

Helpline 24/24 : 0 825 826 117  
E-Mail : helpline@lenze.fr

Agences en France

### Région France Nord :

Z.A. de Chanteloup  
Rue Albert Einstein  
93603 AULNAY-SOUS-BOIS CEDEX

Lille  
59420 MOUVAUX

Strasbourg  
67960 ENTZHEIM

Rouen  
76500 ELBEUF

### Région France Sud :

Rond point du sans souci  
69578 LIMONEST Cedex

Toulouse  
31400 TOULOUSE

Agen

47270 SAINT-PIERRE DE CLAIRAC

**GREECE**

George P. Alexandris S.A.  
12K. Mavromichali Str.  
185 45 PIRAEUS  
Phone +30 (0)210/41 11 84 15  
Telefax +30 (0)210/41 11 81 71  
4 12 70 58

183 Monastiriou Str.  
546 27 THESSALONIKI  
Phone +30 (0)310/5 56 65 04  
Telefax +30 (0)310/51 18 15

**HUNGARY**

Lenze Antriebstechnik Handelsgesellschaft mbH  
2040 BUDAÖRS  
Gyár utca 2., P.O.Box 322.  
Phone +36 (0)23/501-320  
Telefax +36 (0)23/501-339

**ICELAND**

see DENMARK

**INDIA**

Electronic Service:  
National Power Systems,  
10, Saibaba Shopping Centre  
Keshav Rao Kadam Marg,  
Off Lamington Rd,  
MUMBAI 400 008  
Phone +91 22/2300 5667, 2301 3712  
Telefax +91 22/2300 5668

V3 Controls Pvt. Ltd.  
1, "Devyani", Next to SBI, Baner ITI Road,  
Sanewadi, Aundh.  
PUNE 411 007, MS  
Phone +91 20/25 88 68 62  
Telefax +91 20/25 88 03 50

Mechanical Service:  
Emco Lenze Pvt. Ltd.  
1st Floor, Sita Mauli  
Madanlal Dhingra Road  
Panch Pakhadi, Thane (West)  
MAHARASHATRA 400 602  
Phone +91 22/25 40 54 88  
+91 22/25 45 22 44  
Telefax +91 22/25 45 22 33

**INDONESIA**

P.T. Futurindo Globalsatya  
Jl.: Prof. Dr. Latumenten No. 18  
Kompleks Perkantoran  
Kota Grogol Permai Blok A 35  
JAKARTA 11460  
Buero 1:  
Phone +62 (0)21/766 42 34  
765 86 23  
Telefax +62 (0)21/766 44 20  
Buero 2:  
Phone +62 (0)21/567 96 31  
567 96 32  
Telefax +62 (0)21/566 87 50

**IRAN**

Tavan Ressian Co. Ltd.  
P.O.Box. 19395-5177, No. 44, Habibi St.,  
South Dastour St., Sadr EXP'Way,  
TEHRAN 19396  
Phone +98 21 / 260 26 55  
260 67 66  
260 92 99  
Telefax +98 21 / 200 28 83

**ISRAEL**

Greenshpon Engineering Works LTD  
Bar-Lev Industrial Park  
MISGAV 20179  
Phone +972 4 99 13 18 1  
Telefax +972 4 99 13 47 7

**ITALY**

Gerit Trasmissioni S.p.A.  
Viale Monza 338  
20128 MILANO  
Phone +39 02 / 270 98.1  
Telefax +39 02 / 270 98 290

**JAPAN**

Miki Pulley Co., Ltd.  
1-39-7 Komatsubara  
Zama-city  
KANAGAWA 228-8577  
Phone +81 (0)462/58 16 61  
Telefax +81 (0)462/58 17 04

**LATVIA**

see LITHUANIA

**LITHUANIA**

Lenze UAB  
Breslaujos g.3  
44403 KAUNAS  
Phone +370 37 407174  
Telefax +370 37 407175

**LUXEMBOURG**

see BELGIUM

**MACEDONIA**

Lenze Antriebstechnik GmbH  
Pretstavništvo Skopje  
ul. Nikola Rusinski 3/A/2  
1000 SKOPJE  
Phone +389 2 30 90 090  
Telefax +389 2 30 90 091

**MALAYSIA**

D.S.C. Engineering SDN BHD  
3A & 3B, Jalan SS21/56B  
Damansara Utama  
47400, PETALING JAYA, SELANGOR  
Phone +60 (0)3 / 77 25 62 43  
77 25 62 46  
77 28 65 30  
Telefax +60 (0)3 / 77 29 50 31

Lenze S.E.A. Sdn Bhd  
Damansara Technology Park  
No. 28, Jalan PUJ 3/47  
47810, PETALING JAYA, SELANGOR

**MAURITIUS**

Automation & Controls Engineering Ltd  
3, Royal Road, Le Hochet, Terre Rouge  
MAURITIUS  
Phone +230 248 8211  
Telefax +230 248 8968

**MEXICO**

Automatización y Control  
de Energía S.A. de C.V.  
Av. 2 No. 89 Esq Calle 13  
Col. San Pedro de los Pinos  
C.P. 03800 MEXICO D.F.  
Phone +52 (55)5277/5998  
Telefax +52 (55)5277/5937

**MOROCCO**

GUORFET G.T.D.R  
Automatisation Industrielle  
Bd Chefchaouni Route 110 km, 11.500  
No. 353-Ain-Sabaa  
CASABLANCA  
Phone +212/22-35 70 78  
Telefax +212/22-35 71 04

**NETHERLANDS**

Lenze B.V., Postbus 31 01  
5203 DC'S-HERTOGENBOSCH  
Ploegweg 15  
5232 BR'S-HERTOGENBOSCH  
Phone +31 (0)73 / 64 56 50 0  
Telefax +31 (0)73 / 64 56 51 0

**NEW ZEALAND**

Tranz Corporation  
343 Church Street  
P.O. Box 12-320, Penrose  
AUCKLAND  
Phone +64 (0)9 / 63 45 51 1  
Telefax +64 (0)9 / 63 45 51 8

**NORWAY**

Dtc- Lenze as  
Stallbakken 5, 2005 RAEILINGEN  
Phone +47 / 64 80 25 10  
Telefax +47 / 64 80 25 11

**PHILIPPINES**

Jupp & Company Inc.  
Unit 224 Cityland Pioneer Bldg.,  
Pioneer Street  
MANDALUYONG CITY  
Phone +63 2/687 7423  
683 0042  
683 0047  
Telefax +63 2/687 7421

**POLAND**

Lenze-Rotiv Sp. z o.o.  
ul. Rozdzieńskiego 188b  
40-203 KATOWICE  
Phone +48 (0)32 / 2 03 97 73  
Telefax +48 (0)32 / 7 81 01 80  
Lenze Systemy Automatyki Sp. z o.o.  
Ul. Rydygiera 47  
87-100 TORUN  
Phone +48 (0)56 / 6 58 28 00  
6 45 34 60  
6 45 35 70  
Telefax +48 (0)56 / 6 45 33 56

**PORTUGAL**

Costa Leal el Victor  
Electronica-Pneumatica, Lda.  
Rua Prof. Augusto Lessa, 269,  
Apart. 52053  
4202-801 PORTO  
Phone +351-22/5 50 85 20  
Telefax +351-22/5 02 40 05

**ROMANIA**

see AUSTRIA

**RUSSIA**

Inteldrive  
1 Buhvostova Street 12/11  
Korpus 18 Office 322  
MOSCOW 107258  
Phone +7 (0)095 / 963 96 86  
Telefax +7 (0)095 / 962 67 94

**SERBIA-MONTENEGRO**

see MACEDONIA

**SINGAPORE**

see MALAYSIA

**SLOVAC REPUBLIC**

ECS Sluzby spol. s.r.o.  
Staromlynska 29  
82106 BRATISLAVA  
Phone +421 2 45 25 96 06  
+421 2 45 64 31 47  
+421 2 45 64 31 48  
Telefax +421 2 45 25 96 06

**SLOVENIA**

Lenze pogonska tehnika GmbH  
Zbiljska Cesta 4  
1215 MEDVODE  
Phone +386 (0)1 361 61 41  
Telefax +386 (0)1 361 22 88

**SOUTH AFRICA**

S.A. Power Services (Pty.) Ltd.  
Unit 14, Meadowbrook Business Estates  
Jacaranda Ave, Olivevale  
Randburg 2158, P.O.Box 1137  
RANDBURG 2125  
Phone +27(11) 462-8810  
Telefax +27(11) 704-5775

**SOUTH KOREA**

Hankuk Mechatro Ltd.  
Room# 1409, Samhwan officetel 830-295  
Beomil-dong, Dong-Gu  
PUSAN  
Phone +82 (0)51-635-6663  
Telefax +82 (0)51-635-6632

**SPAIN**

Lenze Transmisiones, S.A.  
(Headquarter)  
Mila i Fontanals, 135-139  
08205 SABADELL  
Barcelona  
Phone +34 937 207 680  
Telefax +34 937 120 215

Lenze Delegación Bilbao  
P.I. Ibarra Barr. Ed. METRO 2º-E  
48940 LEJONA  
Vizcaya  
Phone +34 944 630 510/ 507  
Telefax +34 944 314 196

**Lenze Delegación Levante**

Cullera, 73 - 4ºD  
46035 BENIMAMET  
Valencia  
Phone +34 963 905 220/335  
Telefax +34 963 900 647

**Lenze Delegación Madrid**

Arturo Soria, 187 - Of. 8  
28043 MADRID  
Phone +34 915 103 341  
Telefax +34 915 102 061

**SWEDEN**

Lenze Transmissioner AB  
P.O.Box 10 74, Attorps gatan, Tornby Ind.  
58110 LINKÖPING  
Phone +46 (0)13 / 35 58 00  
Telefax +46 (0)13 / 10 36 23

**SWITZERLAND**

Lenze Bachofen AG  
Ackerstrasse 45  
8610 USTER  
Phone +41 (0) 43 399 14 14  
Telefax +41 (0) 43 399 14 24  
Vente Suisse Romande:  
Route de Prilly 25  
1023 CRISSIER  
Phone +41 (0)21 / 63 72 19 0  
Telefax +41 (0)21 / 63 72 19 9

**SYRIA**

Zahabi Co.  
8/5 Shouhaday Street  
P.O.Box 8262  
ALEPPO-SYRIA  
Phone +963 21 21 22 23 5  
Telefax +963 21 21 22 23 7

**TAIWAN**

ACE Pillar Co. Ltd.  
No.12, Lane 61, Sec. 1,  
Kuanfu Road  
San-Chung City  
TAIPEI HSIEN  
Phone +886 (0)2 / 299 58 40 0  
Telefax +886 (0)2 / 299 53 46 6

**THAILAND**

PackSys Global (Thailand) Ltd.  
429 Moo 7, Theparak Road,  
Tambol Theparak  
Amphur Muang  
SAMUTPRAKARN 10270  
Phone +66 2 383 5633  
Telefax +66 2 383 5637

**TUNESIA**

AMF Industrielle Sarl  
Route de Gremda - Km 0,2  
Immeuble El Madina,  
Centre Bloc B - 5 ème - appt 52  
3002 SFAIX  
Phone +21674 403 514  
Telefax +21674 402 516

**TURKEY**

LSE Elektrik  
Elektronik Makina  
Otomasyon Mühendislik  
San. Ve Tic. Ltd. Şti.  
Atatürk mah. Cumhuriyet cad.  
Yurt sok. No:7  
ÜMRANIYE/İSTANBUL  
Phone +90 (0)216 / 3165138 pbx  
Telefax +90 (0)216 / 443 4277

Bursa Address:  
Demirtaspa Mh.  
Ata Sk. Petek Bozkaya Is Merkezi  
D Blok No :5 / A  
OSMANGAZI / BURSA  
Phone +90 (0)224-2733232 pbx  
+90 (0)224-2734151  
+90 (0)224-2733238  
Telefax +90 (0)224-2734150

**UKRAINE**

SV Altera, Ltd.  
Lepse ave., 4  
KIEV, 03067  
Phone +38 044 496 18 88  
Telefax +38 044 496 18-18

**UNITED ARAB EMIRATES**

LPT (FCZ)  
Executive Suite X4-37  
P.O. Box: 9304, SAIF ZONE  
SHARJAH AIRPORT INTERNATIONAL  
FREE ZONE (SAIF ZONE)  
Phone +971 6 5573205  
Telefax +971 6 5573206

**UNITED KINGDOM/IRE**

Lenze Ltd.  
Caxton Road  
BEDFORD MK 41 OHT  
Phone +44 (0)1234 / 32 13 21  
Telefax +44 (0)1234 / 26 18 15

**USA**

AC Technology Corp.  
630 Douglas Street  
UXBRIDGE, MA 01569  
Phone +1 508 / 278-9100  
Telefax +1 508 / 278-7873

Lenze Corporation  
1730 East Logan Avenue  
EMPORIA, KS 66 801  
Phone +1 620 / 343-8401  
+1 888 / 269-2381  
Telefax +1 620 / 342-2595  
+1 800 / 469-0931

Lenze DETO Drive Systems USA, LLC  
5912 Sterling Drive  
HOWELL, MI 48843  
Phone +1 517 / 586-4057  
Telefax +1 517 / 586-4058

Lenze Drive Systems GmbH  
Hans-Lenze-Straße 1  
D-31855 Aenzen  
Germany



+49 (0) 51 54 82-0



Service 00 80 00 24 4 68 77 (24 h helpline)



Service +49 (0) 51 54 82-1112

E-Mail [Lenze@Lenze.de](mailto:Lenze@Lenze.de)

Internet [www.Lenze.com](http://www.Lenze.com)

BA33.0001 2.0 06/2005  
© 2005  
TD09

