

Hall-Effect Vane Sensor 2AV63

INTRODUCTION

ChenYang Hall-Effect Vane Sensor 2AV63 is designed to work in the conditions of automobile environment. The device is produced in compliance with the international standard and has the features: modern design, accurateness, endurance, narrow temperature drifting, smooth and clean output curve as well as non instantaneous dithering.

The sensor is applicable to engines with electronic ejection. The main applications are in automobile industry, i.e. as a breakerless trigger in electronic systems, in control engineering, especially in those areas where switches/ sensors must operate maintenance-free under harsh environmental conditions, e.g. rpm sensors, limit switches, position sensors, speed measurements, shaft encoders, scanning of coding disks etc.

The 2AV63 is replacement for the similar products 2AV54, 2AV16A, 2AV51A and 2AV56. They are compatible in electrical and mechanical properties but with different circuitry principle.

CROSS REFERENCE (Table 1)

Part Number	Replacement
2AV63	2AV54, 2AV16A, 2AV51A, 2AV56, 2AV63

FEATURES

- Contactless switch/sensor with open collector output (40mA)
- Static switching/sensing
- High switching/sensing frequency
- Hermetically sealed with plastic
- Unaffected by dirt, light and vibration
- Large temperature and voltage ranges
- Integrated protection of overvoltage etc.

The Hall Effect vane sensor 2AV63 is a non-contact sensor/switch, which consists of a monolithic integrated Hall Effect circuit and a special magnetic circuit hermetically sealed in a plastic package. The sensor is actuated by a soft-iron vane passing through the air gap between magnet and Hall sensor.

MEASURING PRINCIPLE

The Hall Effect vane sensor consist of a Hall IC and a permanent magnet (SmCo, NdFeB disc or block), which are hermetically sealed in plastic (see the following figures). The sensor is actuated by a soft iron vane that passes through the air gap between the magnet and Hall IC. The open collector output is conductive (low) when the vane is outside the air gap (see Fig. a)), and blocks (high) when the vane moves into the air gap (see Fig. b)). The output remains high as long as the vane positions in the air gap. This is the so called static function. The output signal shape is in this case independent on the operating frequency.

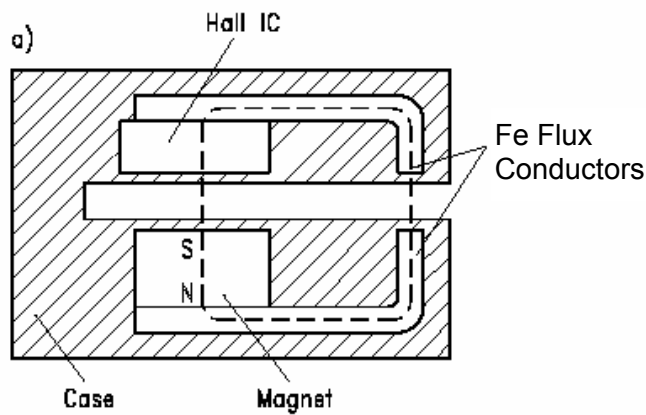

a) Magnetic flux through the Hall-effect switch with no vane in the gap

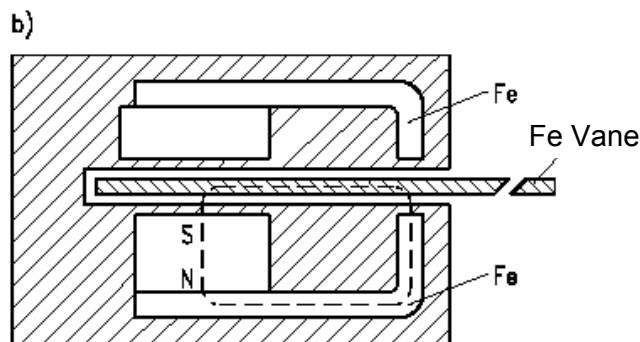

b) Magnetic flux short-circuited by the soft-iron vane

Overvoltage is integrated in the circuit in order to protect against most of the voltage peaks occurring in automotive and industrial applications. The output stage has a Schmitt trigger characteristic. Most of electronic circuits can be driven directly thanks to the open collector output current of maximum 40mA.

MECHANICAL CHARACTERISTICS

The Hall Effect vane sensor is hermetically sealed in a special plastic package, so that it can also be used under harsh environmental conditions. The package is waterproof, resistant to vibration, gasoline, oil and salt. Two tubular rivets are incorporated in the package to mount the sensor on the carrier plate. The sensor has three leads for power supply, output and ground.

ABSOLUTE MAXIMUM RATINGS (Table 2)

Supply Voltage	30V
Reverse Battery Voltage	- 40V
Output OFF Voltage	40V
Reverse Output Voltage	- 0.5V
Output Current (at TA=25°C)	40mA for 5 minutes max
Operating Temperature Range	- 40°C~ +150°C
Storage Temperature Range	- 40°C~ +175°C

ELECTRICAL CHARACTERISTICS at $V_{cc}=12V$ (Table 3)

Supply Voltage	4.5V~24V
Supply Current	$\leq 9mA$
Output Saturation Voltage(Sinking 20mA)	$\leq 0.4V$
Output Leakage Current	$\leq 10\mu A$
Output Rise Time	$\leq 2\mu S$
Output Fall Time	$\leq 2\mu S$
Output type	NPN (OC)

MECHANICAL PARAMETERS (Table 4)

Part number	De(mm) operation distance			Da(mm) release distance		
	Min	Typ	Max	Min	Typ	Max
2AV63	0.85	1.45	2.05	1.54	2.29	3.04

Test conditions: $V_{cc}=12\pm 0.1V$, $T_A=25\pm 5^\circ C$, $h=7.1\pm 0.2mm$, $e_1=e_2$

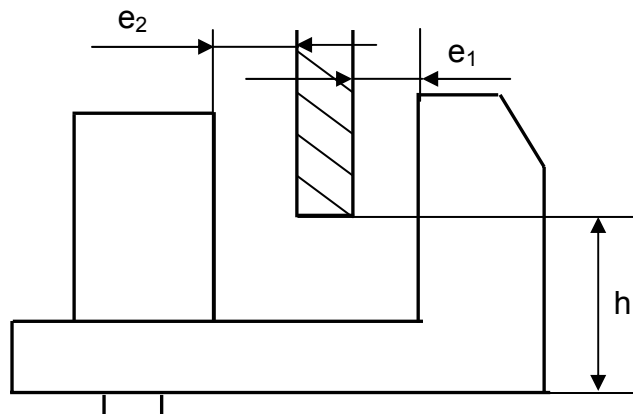

VIBRATION LEVEL:

At ambient operating temperature:	+90°C
Frequency range:	100Hz ~ 500Hz
Amplitude:	100 μm
Acceleration:	300m/s ²

Vibration in X,Y,Z direction, 8 hours per direction, 24 hours total

TESTS

The following tests are made according to Chinese Standards and International Standards:

- 1) Shock Test: Acceleration: 30g, Time: 18ms, De and Da are within the range defined in Table 4
- 2) Vibration Test: Acceleration: 10g, frequency 10Hz-150Hz, continuous vibration, 15times, De and Da are within the range defined in Table 4
- 3) Low Temperature Test: -40°C , 24h, the deviations of De and Da are within $\pm 0.2\text{mm}$
- 4) High Temperature Test: $+150^{\circ}\text{C}$, 48h, the deviations of De and Da are within $\pm 0.2\text{mm}$
- 5) Temperature Shock Test:

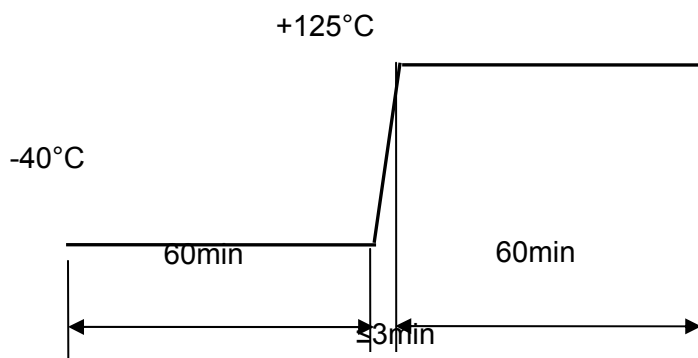

The deviations of De and Da are $\pm 0.2\text{mm}$

- 6) Test under Humid Conditions: temperature 40°C , humidity: 90% ~ 95%, 48h, De and Da are within the range defined in Table 4
- 7) High Voltage Test: 800V DC between any two leads
- 8) Steady-load Test: under max. load, 130°C , 240h, the deviations of De and Da are within $\pm 0.2\text{mm}$

APPLICATION NOTES

The output of these sensors is sinking current (OC, open collector). A pull-up resistor ($1\text{k}\Omega \sim 10\text{k}\Omega$) should be connected to the sensor output circuit (between power supply + and output).

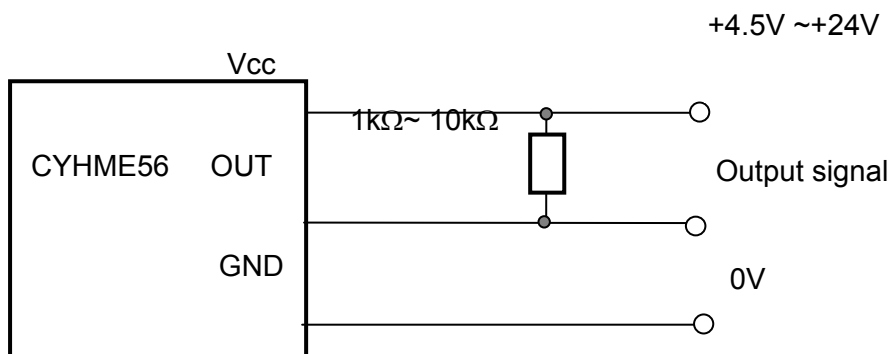

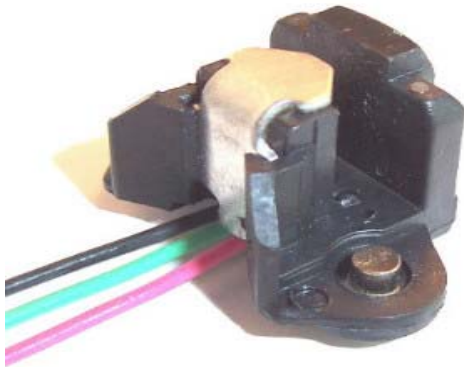

The standard length of the leads is 150mm
Diameter: $\varnothing 1.4\text{mm}$

Red (Vcc) Green (OUT) Black (GND)

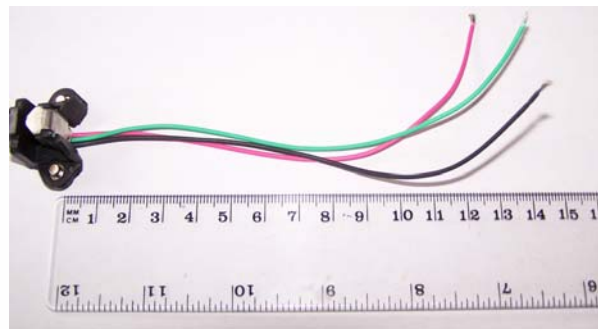
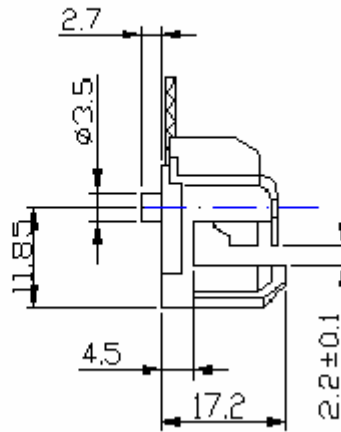
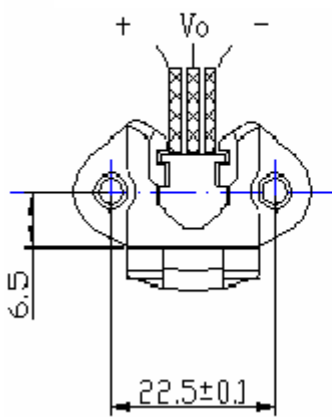

The type and length of the leads can be made according to customer's requirements