

**SG1-80 w/o Mounting Bracket:**

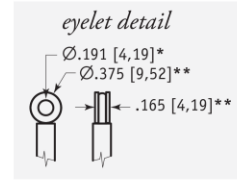

\*tolerance = +.005 -.001 [+13 -.03]  
 \*\*tolerance = +.005 -.005 [+13 -.13]

**SG1-120 w/o Mounting Bracket:**

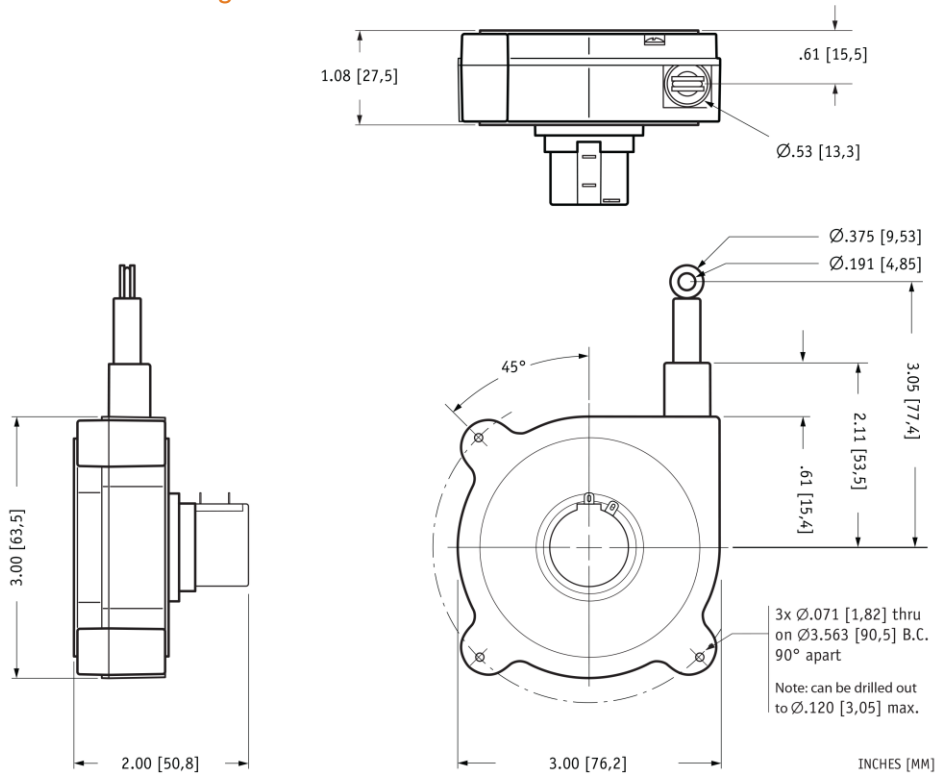
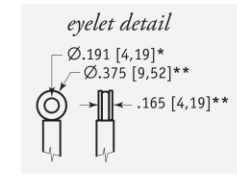
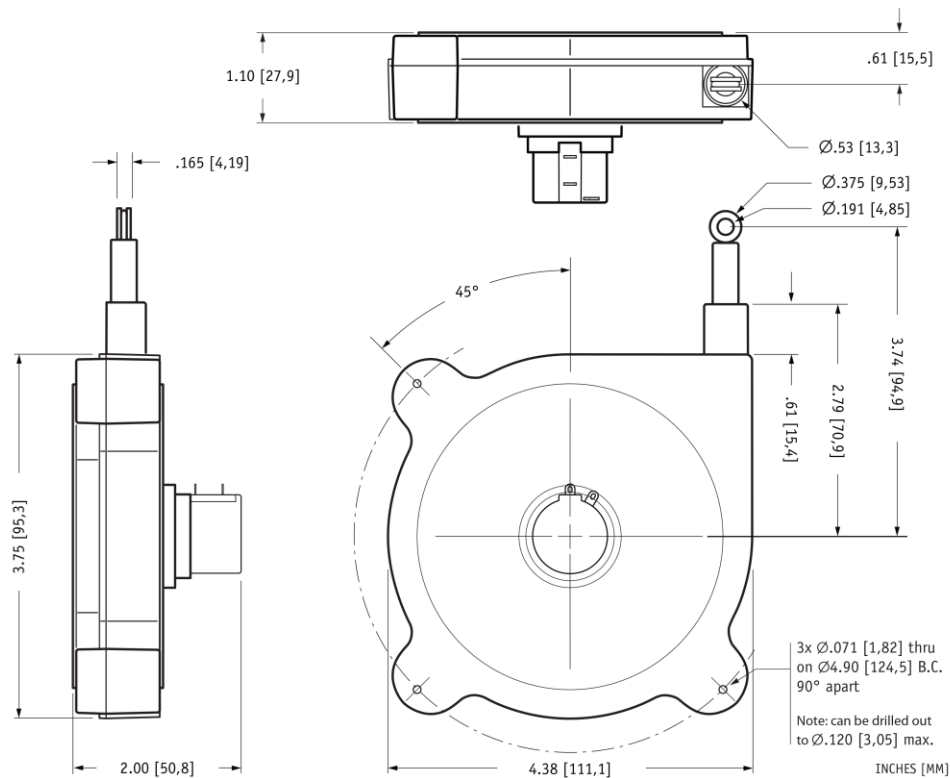

\*tolerance = +.005 -.001 [+13 -.03]  
 \*\*tolerance = +.005 -.005 [+13 -.13]

**SG1-80 w/ Mounting Bracket:**

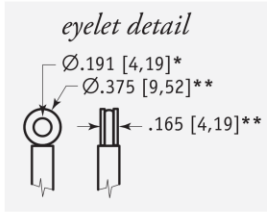

\*tolerance = +.005 -.001 [+13 -.03]  
 \*\*tolerance = +.005 -.005 [+13 -.13]

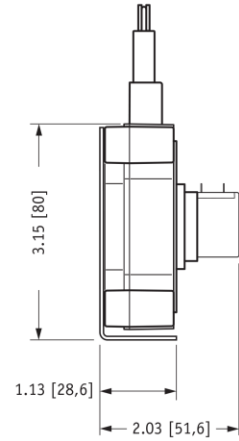
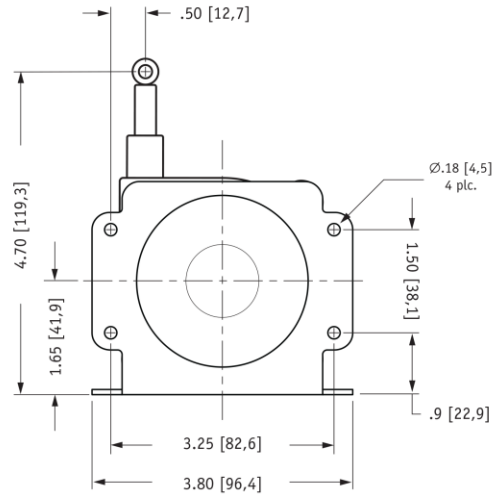
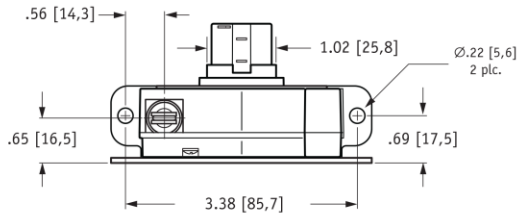

INCHES [MM]

**SG1-120 w/ Mounting Bracket:**

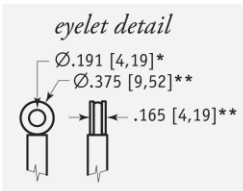

\*tolerance = +.005 -.001 [+13 -.03]  
 \*\*tolerance = +.005 -.005 [+13 -.13]

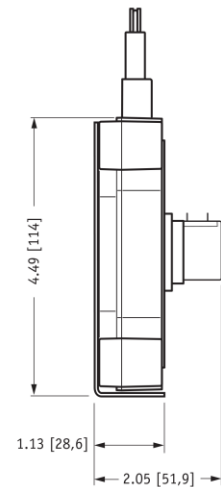
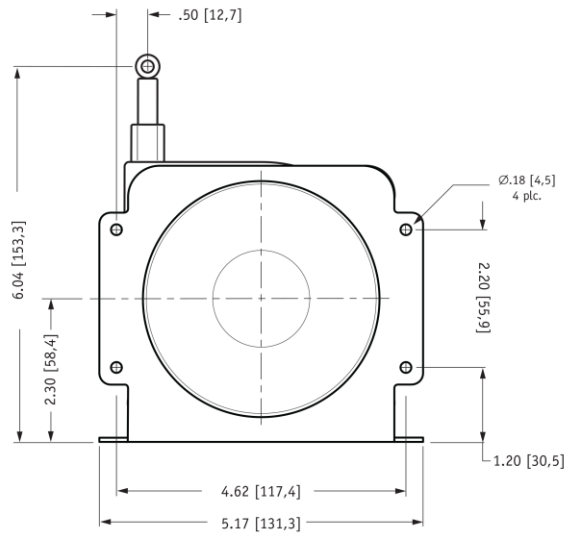
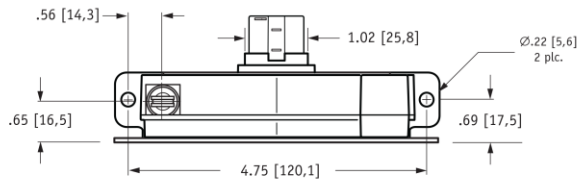

INCHES [MM]