

## X20 System Slice-based I/O and control system

There are many different slice based I/O and control systems.  
With the X20 System, B&R is setting new standards  
according to the motto "Perfection in Automation".



## Table of contents

<b>System characteristics .....</b>	<b>40</b>
<b>Product overview .....</b>	<b>68</b>
<b>Product data sheets .....</b>	<b>86</b>
<b>Accessories .....</b>	<b>388</b>
<b>Mechanical and electrical configuration .....</b>	<b>392</b>

## System characteristics



### The new standard for automation

There are many different I/O slice systems. With the X20 System, B&R is setting new standards according to the motto "Perfection in Automation". Born from experience gained from applications all over the world, numerous conversations with customers, and with the aim for more simple, economical and secure usage, the X20 System is the new universal solution for any automation task in machine and system manufacturing.

### More than just I/O

With well thought-out details and a sophisticated ergonomic design, the X20 System is more than a remote I/O system, it is a complete control solution. The X20 System family makes it possible to combine the exact components necessary depending on the user's demands and individual application requirements.

- The X20 System is the ideal addition to a standard fieldbus and expands the possibilities of standard control systems. Simply connect it and configure it.
- Teamed up with other B&R components, the X20 System achieves its full potential and allows the implementation of applications with unimagined performance and flexibility. Seamless integration is a major advantage.

### 3 x 1 = One

Three basic elements result in one module:

Terminal block – Electronic module – Bus module

This modularity results in a system that combines the advantages of both rack and I/O slice systems:

- Prewiring without the module
- Hot pluggable electronics
- Extra bus slots for added options

**The X20 System is distinguished by a 50% increase in component density, perfected connection technology and optimal granularity.**

### • Added value

12 channels with a width of 12.5 mm allow a component density never before achieved with optimal terminal ergonomics. As a result, the X20 System offers 50% more channels than conventional slice systems. And this without sacrificing terminal connections.

### • Continuity

Consistent implementation of 1-wire, 2-wire or 3-wire connections - no additional jumper terminals needed.

### • Granularity

One channel and two channel modules: Maximum flexibility so you only have to pay for what you really need.



## Optimally designed

X20 modules are divided into three parts to guarantee the simplest applicability throughout their entire lifecycle. The division into bus module, electronic module and terminal block provides many advantages.

- **Preconfigured for different machine types**

The X20 System bus modules are the basic platform for many machine variations. The design of the machine determines which electronics modules are used. The software recognizes the layout automatically and provides the necessary functions. Handling a range of machine types couldn't be easier.

- **Industrial switching cabinet construction**

The X20 System terminal blocks, which are separated from the electronics modules, make it possible to prewire complete switching cabinets. Ideal for series production machines.

- **Easy maintenance**

X20 modules can be easily exchanged to simplify troubleshooting. The electronic modules can be exchanged without interrupting operation. The wiring stays the same thanks to the separate terminal blocks. Being able to exchange the automation components quickly reduces down-time.



## System characteristics

### Remote backplane

The main idea: Decentralized backplane for a rack system - in other words, the cable is the backplane. All modules are connected using a uniform backplane (X2X Link). Directly connected X20, X67 or XV modules can each be placed at a distance of up to 100 m outside the confines of the switching cabinet. X2X Link guarantees the highest possible level of resistance to disturbances based on twisted copper cables.

This results in a universal remote backplane that handles communication between bus modules as well as communication via the X2X Link cable, without converters or any loss in performance. A unique feature of the X20 is the possibility to later integrate machine options on bus modules that are not yet being used without having to change the software addressing.

Note: A 100 m X2X Link cable is available from B&R for custom prefabrication (model number: X67CA0X99.1000).

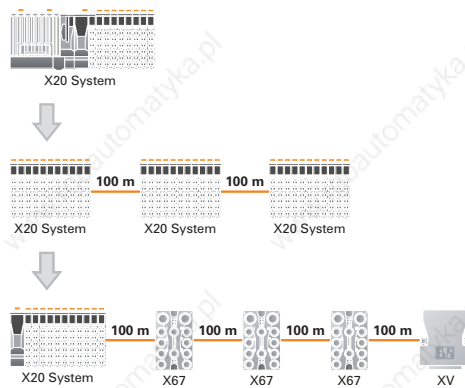

## X20 CPUs

### General information

The new, optimally scaled X20 System CPU line satisfies a wide range of needs. It can be implemented anywhere, from standard applications to the most demanding applications with the highest performance requirements. It can even effectively handle cycle times of 200  $\mu$ s.

At B&R, RS232, Ethernet and USB are already standard equipment. Network capability and connecting USB devices are therefore possible at no additional cost. In addition, every CPU has a POWERLINK connection for real-time communication. The possibility to directly connect axes is already integrated. Although most demands are met by a standard CPU, there are up to three multipurpose slots for additional interface modules.

Because the X20 CPU was designed for mounting rail installation in a switching cabinet, up to 250 X20 I/O modules - 3000 channels - can be connected directly. This provides the highest performance as well as the advantages of the remote backplane.



## System characteristics

### Remote backplane

A power supply integrated in the CPU with I/O supply terminals provides power for the backplane and I/O sensors and actuators, eliminating the need for additional system components. With a direct I/O connection to an X20 CPU, you get all the advantages of the remote backplane, i.e. the ability to repeatedly place I/O line sections anywhere within 100 m using a cable or to add modules with IP67 protection.

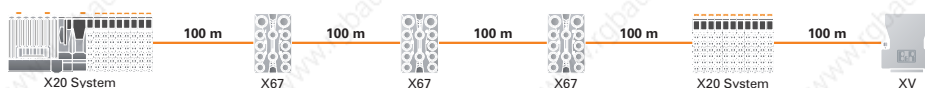

### B&R Automation Studio

B&R Automation Studio is the only programming tool needed for all platforms. All relevant IEC61131-3 languages and C can be used to create the application software. Integrated visualization, NC and soft CNC functions and Web server technologies complete the range of useful features.

### PC-based technology

Based on the latest Intel Celeron processor technology, the X20 CPUs can utilize 200  $\mu$ s cycle times. Large amounts of RAM grant the user unrestricted freedom with applications. It is complemented by a battery buffered non-volatile SRAM for task specific data and remanent variables. In the case of a power outage, variables that have been declared as being remanent are automatically copied from the fast RAM to the secure SRAM. The data content remains in tact until the controller is restarted, and the process can simply be resumed. In addition, a slot for CompactFlash cards is integrated in the system for saving programs or application data, such as recipes.



## System characteristics

### Suitable for industrial use

Providing the highest performance, with many standard interfaces and interface modules for expansions, yet the dimensions are unbelievably compact. The dimensions of the CPU match those of the X20 modules, which prevents unnecessary waste of space in the switching cabinet.

Fan-free operation - a demand the X20 CPUs can satisfy. None of the processors requires a fan, which makes them virtually maintenance-free. To permit the Celeron 650 CPU to operate over the entire temperature range, it comes with a fan.

Preventative maintenance is possible thanks to monitoring the function of the fan, monitoring the temperature of the processor and the ability to exchange the fan from the outside without a tool and without removing the CPU.



## X20 Compact CPUs

### General information

With a width of 37.5 mm the new X20 Compact CPUs are extremely compact, yet surprisingly powerful. Less powerful than the PC-based CPUs, there are several models of Compact CPU available in two performance classes.

The Compact CPUs are ideal for situations where cycle times in the millisecond range are acceptable and value is the deciding factor. A range of models with CAN and Ethernet can adapt optimally to all demands. The result: extremely sleek automation solutions.

The Compact CPU's design and dimensions correspond to the X20 System. The X20 I/O modules are connected directly to the CPU.

These are attached seamlessly to the CPU, making the entire system an extreme space saver in the switching cabinet. Despite the sleek profile, the CPU supply, the X2X Link supply, and the I/O module supply are integrated in the system. No additional power modules are necessary.

All CPUs have at least two things in common: multitasking capability and programming with B&R Automation Studio using all relevant IEC61131-3 languages and C.

### Product range

The product range begins with the sleekest solution, the X20 Compact CPU equipped with an RS232 online interface and the integrated X20 module connection. Selecting another bus module adds a CAN interface to the solution. The top end of the product range includes CPUs with a Fast Ethernet interface. The design with Ethernet is also available as a variant with approximately 60% more processing power.



# System characteristics

## X20 fieldbus CPUs with integrated fieldbus connection

### General information

Remote design of I/O systems is one of the standard topologies used in automation solutions for machines and equipment. In addition, fieldbuses with bus controllers are normally used. Larger topologies or standard fieldbuses like CANopen, Profibus DP, or DeviceNet can cause relatively long reaction times.

An input must travel via the bus controller to the CPU before it is processed. The output data must then return on the same path. This is sufficient for most I/O functions. However, this reaction time is too long for some functions. The best solution is for the bus controller to process the data. This type of data preprocessing is usually associated with limited CPU function in the programmable bus controller.

Fieldbus CPUs with integrated fieldbus connection overcome these limitations. Fieldbus CPUs are variations of Compact CPUs. In addition to these features, there is also the option of connecting fieldbus modules to the left side. The full CPU function of the Compact CPUs plus a plug-in fieldbus module create many more possibilities than simply data preprocessing. There are enough reserves for relatively complex application processing. Intelligent substations are another area of use. That means a part of the machine must continue to function, even when separated from the main controller.

Based on the Compact CPU platform with up to two plug-in interface modules for the respective fieldbus connection, this results in a very compact (62.5 mm), powerful, and intelligent fieldbus controller.

### Product range

As with Compact CPUs, the new CPUs with fieldbus connection are available in two performance classes. Depending on the bus module being used, the CPU has an RS232 interface or an RS232 interface supplemented with a CAN interface. The CPU with higher processing power is available with or without an Ethernet onboard interface. Various fieldbus modules are available.

### Programming

All CPUs have several features in common, including integrated connection of X20 modules and system multitasking capability. With B&R Automation Studio, programming can be done in all IEC 61131-3 languages and in C.



## Integration of all standard fieldbuses

The X20 System is ideally suited for expanding existing control systems using standard fieldbus technology.

Using bus controllers, the X20 System can be used as a powerful I/O expansion unit. Standardized EDS or GSD description files allow X20 System components to be easily integrated, configured, and programmed in a non-B&R system programming environment.

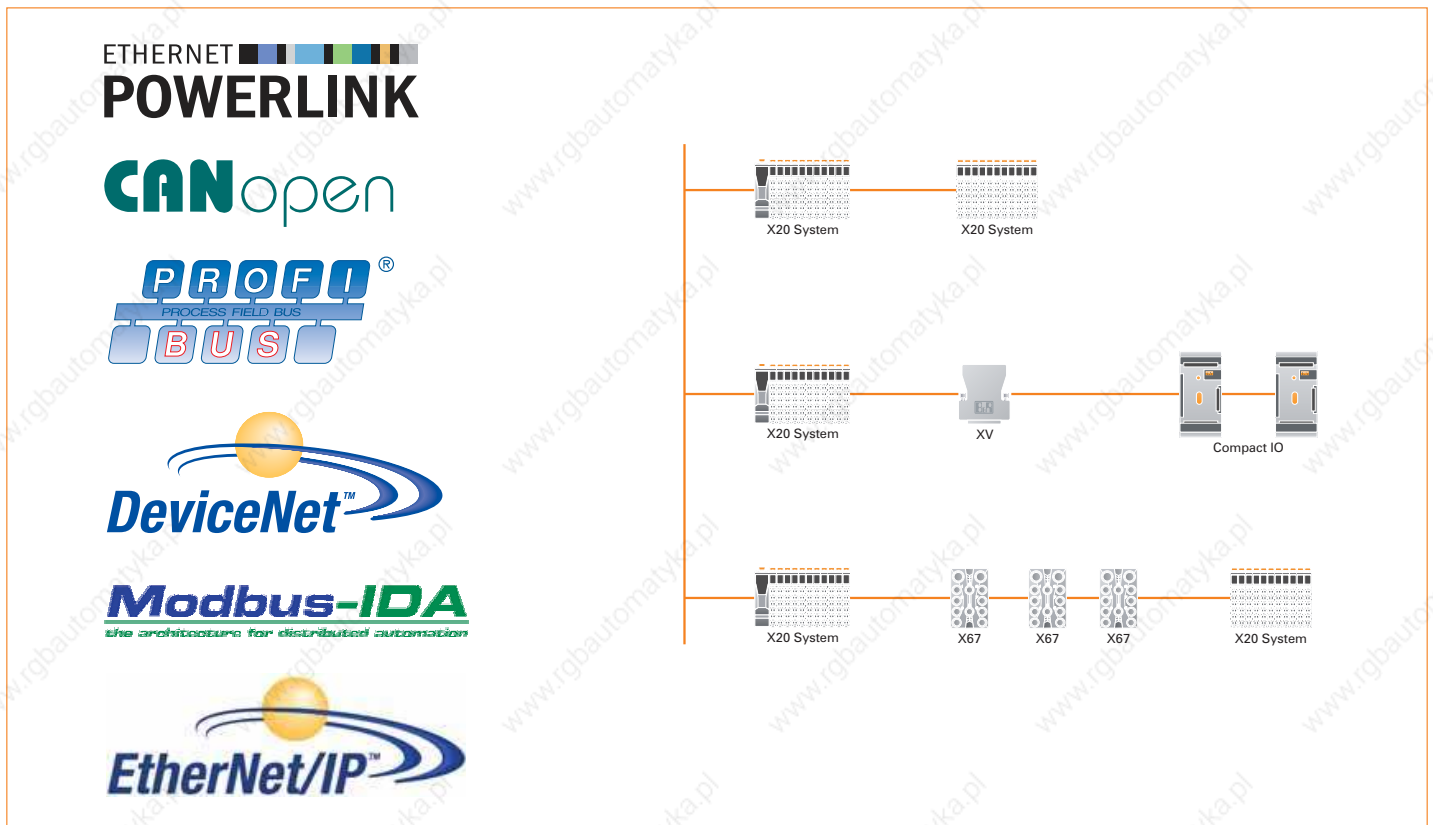

## System characteristics

### Complete system

#### X67 - with IP67 protection

The X67 is the more robust version of the X20 for use outside the switching cabinet. The same basic technology, with an extremely robust housing and 4 to 32 channel modules, guarantees economical solutions in the roughest conditions (X67 System, 419).

#### Integrated valve manifold control

The development of the XV system now allows direct and manufacturer-independent control of valve manifolds. A complete digital output module in a size and form comparable with a normal DSUB connector. XV allows any valve manifold manufacturer to be selected because it is connected directly to the standardized multiple pin connector on the valve manifold. Fully integrated in the remote backplane, it rounds off the X20 and X67 for complete automation solutions (XV System, 569).

One system, several variations - advantages that pay off. You select your automation components and distribute them as needed inside and outside the switching cabinet.

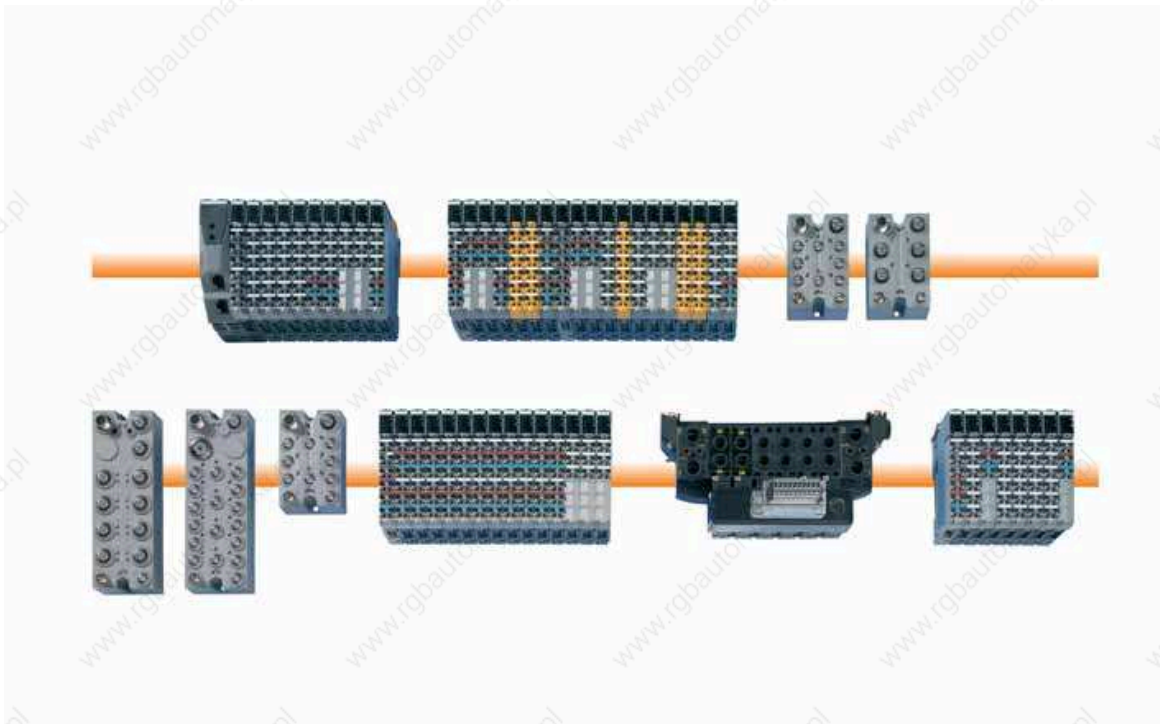

## Easy wiring

Industrial switching cabinet construction streamlines production cycles. Prefabricated cable trees enable faster and easier assembly directly on the machine or system. The X20 System supports efficient prewiring of the entire switching cabinet using separate terminal blocks. The complete X20 System configuration is mounted in the switching cabinet and connected to the prewired cable trees. The supply of the X20 modules and the supply of the sensors and actuators do not add any requirements for energy distribution. The X20 System reduces manual wiring to a minimum.

### Install the wires, plug it in, and it's ready to go

Simple, tool-free wiring for fast installation. The X20 System terminal blocks use a fully-integrated and proven push-in connector system. Each terminal can also handle double wire sleeves up to a diameter of  $2 \times 0.75 \text{ mm}^2$ . The user saves time wiring the system and distributing the signals. The wire connections can be removed with a screwdriver. Each terminal also has an access point for a measurement probe. A great deal of thought was given to designing every aspect the X20 System. Right down to the wire connectors.

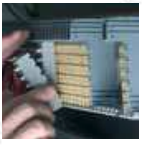

#### Detached

The terminals can be prewired apart from the actual I/O module. This provides many advantages for switching cabinet construction. Separate manufacturing, just-in-time logistics and the installation of preassembled systems during start-up become reality.

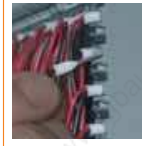

#### Tool-free

Simple, tool-free wiring for fast installation. The X20 System terminals use a fully-integrated and proven push-in connector system. Available with 6-pin and extremely compact 12-pin terminals.



#### Coded in the system

Factory coding prevents dangerous mix-ups. Coding guarantees that only parts that are permitted to be combined can be combined. Intuitively and without additional work.

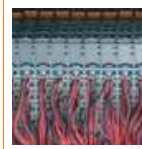

#### Ergonomic

Component density must not come at the expense of ergonomics. With terminal spacing of more than 5 mm, this was handled optimally on the X20 System. Experience gained in the field - used in the field.



#### Coded in the application

Incorrectly inserting terminals does not necessarily damage the electronics, but always causes faulty functioning of the system. Application coding prevents this problem.



#### Clarity

Distinct forms intuitively define various functions, such as clearly assigned latching and unlatching functions for terminals. This prevents errors from the very beginning.



#### Labeling

Each terminal is clearly labeled, directly in the plastic. Additional label tabs are available as system accessories including a printer with ECAD connection.



#### Easy servicing

A system's strengths can be seen in its details: In addition to the terminal connector and unlocking mechanism, each terminal has an access point for a test probe. You can easily measure the terminal potential without disconnecting the wire.

## System characteristics



### Sophisticated mechanics

The name B&R stands for many years of experience in developing and manufacturing industrial electronics. But it's also the mechanics of the X20 System that have been thought through to the last detail. Its robust design, long guides, and strengthened housing guarantee the stability it needs in industrial environments. These features allow the X20 System to be mounted on a rail with the same ease as a rack system. They also make it just as simple to remove it from the rail. The sophisticated mechanics of the X20 are needed not just to provide this type of handling, but also to be able to quickly and easily remove I/O slices from the entire system.



**Unlocking mechanism with two positions**  
Closed for secure fit on the mounting rail.



**Defined open position makes the difference**  
Open to remove a module or the entire system.

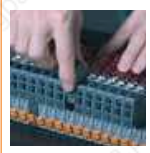

**Removing a single module from the system**  
Remove or re-insert vertically.

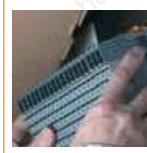

**Mount the entire system as a whole**  
Or just as easily remove the the entire system.

## Diagnostics

Only with outstanding diagnostic options can errors be found quickly. The X20 System offers several levels of diagnostics:

- Directly on the module using visual LED displays. Bus status, I/O status and channel states are displayed in direct relationship to the channels or the function. The different states are displayed in different ways, e.g. green for OK, red for error.
- Via software in the cyclical data image. With the X20 System, status data does not result in additional communication load, which would result in considerable differences between theoretically possible bus speeds and real requirements during operation. All necessary status data is always transferred cyclically, with no exceptions.
- Expanded diagnostic data in non-cyclic data traffic without loss in performance. If a problem occurs, detailed diagnostic data can be requested from the application by the respective module using an asynchronous channel. There is no additional communication load whatsoever, and cycle times remain unchanged.



## Embedded parameter chip

Information such as module type, serial number, functionality and version number is contained in the embedded parameter chip of the X20 module. This information is automatically evaluated by the programming environment (Automation Studio) and by the application program. This prevents errors, during both commissioning and service. In addition, the system configuration is automated and flexible variations are made possible.

Serial numbers of modules that are defined worldwide are gaining increasing significance in validated systems as demanded, for example, in the FDA.

## System characteristics

### Space for options

The X20 System family makes it possible to combine the exact components necessary depending on the user's demands and individual application requirements. This allows machine options to be implemented easily and flexibly. Bus modules provide the base, and are more or less a rack replacement. Depending on the option, the necessary electronics modules are then inserted in the predefined slots. Addresses are assigned implicitly via the slot. Software that has been developed once is valid for all versions and does not need to be changed. This is even possible for later machine expansion. The I/O modules are simply inserted in the defined bus modules, and assigned to the corresponding potential groups and E-stop groups. To prevent unwanted expansion, each module can be identified and then enabled using the application software.

### Flexibility for options

The implementation of different machine variations using free bus modules is only one of the many features that the X20 System offers. With the support of B&R Automation Studio (☐ 1805), there is an optimized solution using I/O configuration. What does this mean?

Each I/O configuration is created optimally according to the actual requirements. However, the application software is already designed for all options. Only the I/O channels that are actually available are configured in the application program. If an expansion is required, then the additional hardware needed can be easily connected and the I/O configuration changed. This is done without having to compile the application software.

It doesn't matter how the I/O configuration list is created:

- Manually in B&R Automation Studio
- With tools, e.g. using a database or a spreadsheet program
- Directly from an ERP system, exactly like with the parts list for the machine
- Automatically in the application software, regardless of the hardware being used

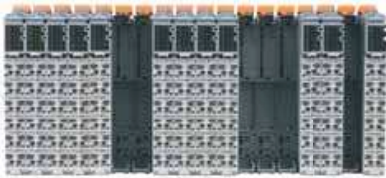

#### Machine variation A

The possibilities of the X20 System can be explained using examples. This is a machine constellation with two variations, A and B. All of the necessary electronics modules for machine variation A are shown in the picture to the left. The bus modules needed for variation B are also present, but without electronic modules.



#### Machine variation B

Variation B shows the necessary electronic modules but the modules necessary for variation A are missing. The distribution of the free bus modules for the variations is also clear: The variable I/O modules can be very easily connected to the required electrically isolated groups and don't need to be attached in the back. The extensive process of taking apart the configuration to expand existing electrically isolated groups is also eliminated. Simply insert the electronic module and put on the terminal block.

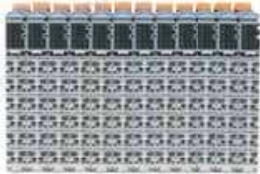

#### Machine variation A - optimized

The features included in Automation Studio can also be used to achieve completely optimized hardware configuration without losing the advantage of comprehensive application software for all variations. As described earlier, simply switching physical I/O points to the application program makes it extremely easy to optimize the hardware variations without even requiring compilation.

### Definable X2X Link address

The decentralized X2X Link backplane, which connects the individual I/O modules with each other, is set up to be self-addressing. It is not necessary to set the node numbers. The module address is assigned according to its position in the X2X Link line.

In certain cases, e.g. when configurations of modular machines change, it is necessary to define specific module groups at a fixed address, regardless of the preceding modules in the line.

For this purpose, there are modules in both the X20 System and the X67 System with node number switches, which allow you to set the X2X Link address. All subsequent modules refer to this offset and are addressed again automatically.

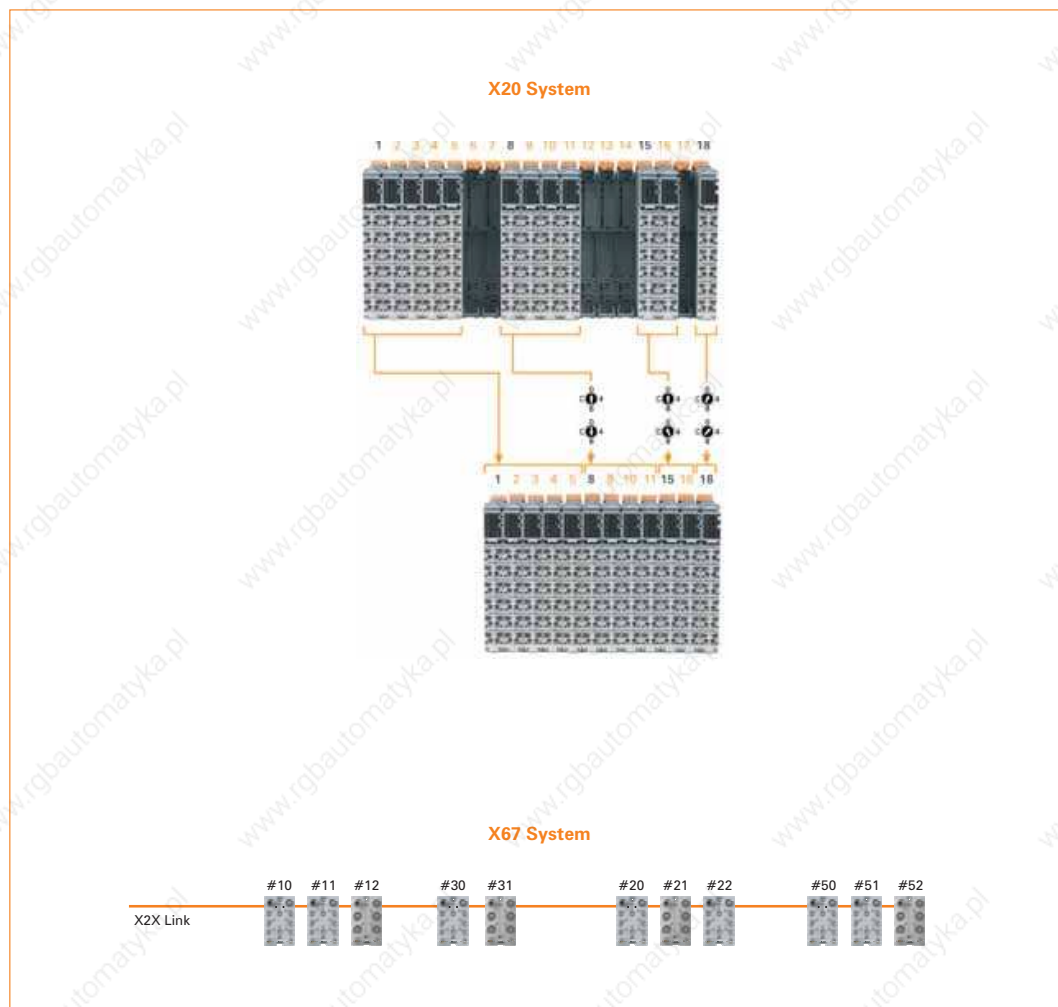

# System characteristics

## Universal 1, 2, or 3 wire technology

Consistent connection types for all requirements – no additional jumper terminals are needed.  
All connection types can also be mixed and matched.



**Universal 3-wire connections**  
Integrated supply and ground for sensors and actuators.

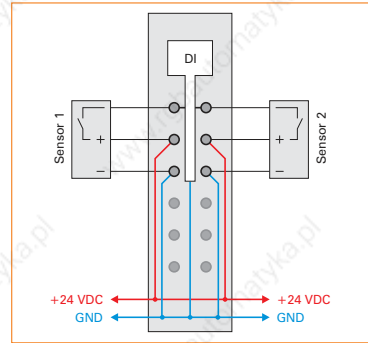

**Universal 2-wire connections**  
Extra terminals are not needed.

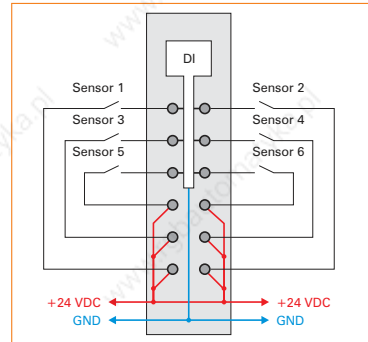

**Universal 1-wire connections**  
12 channels - unequalled component density

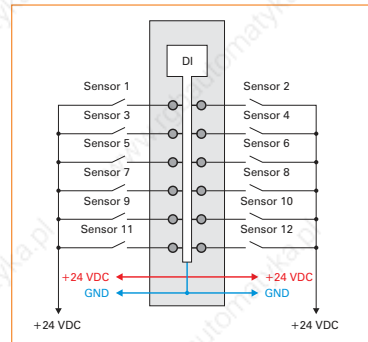

### **POWERLINK cable redundancy system**

It is often indispensable to have redundant network cabling, especially in systems that handle technical processes. The potential for danger, especially to the lines that run through the system, is disproportionately high in relation to the need to keep communication active in all operating situations. This risk is effectively reduced with double cabling that is routed separately.

The POWERLINK cable redundancy system is based on the principle of doubling the transfer routing as well as providing continual and simultaneous monitoring. That means data is simultaneously fed into two cable lines using a corresponding mechanism. The same mechanisms are used to receive these telegrams from the redundant network.

### **X20 redundancy system**

For the POWERLINK cable redundancy system, the following devices were developed based on the X20 System with link selector:

- X20HB8884 compact link selector
- X20BC8084 bus controller

## System characteristics

### Compact link selector HB8884

The compact link selector was developed for connecting POWERLINK V2 controlled nodes. The device structure follows the proven X20 philosophy. The 62.5 mm wide module is operated as a stand-alone unit. That makes it possible to operate all types of POWERLINK V2 devices on a network with cable redundancy.

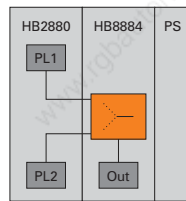

Function principle of the HB8884 compact link selector

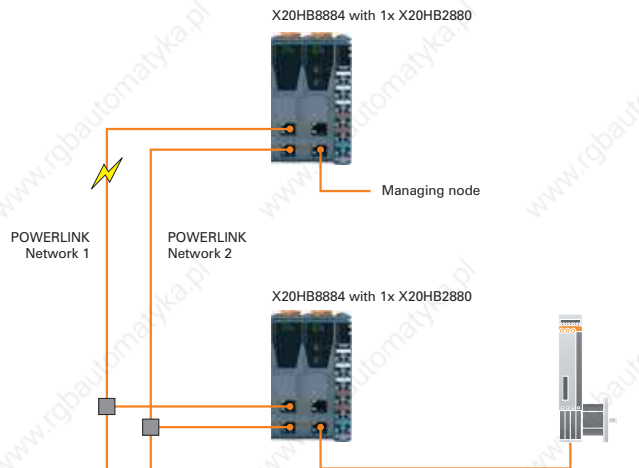

HB8884 with external hubs

### HB8884 with hub expansion modules

Expanding the HB8884 with two active X20HB2885 hub modules eliminates the need to connect external hubs. Two hot-swap capable modules are required so that devices on the out-port can continue operating uninterrupted even when a hub is replaced. Additionally, a redundant supply voltage for the system can be easily implemented using two X20 supply modules.

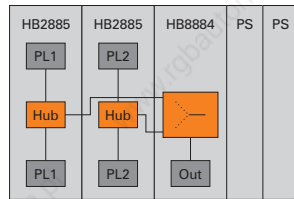

Function principle of the HB8884 compact link selector with hub expansion modules

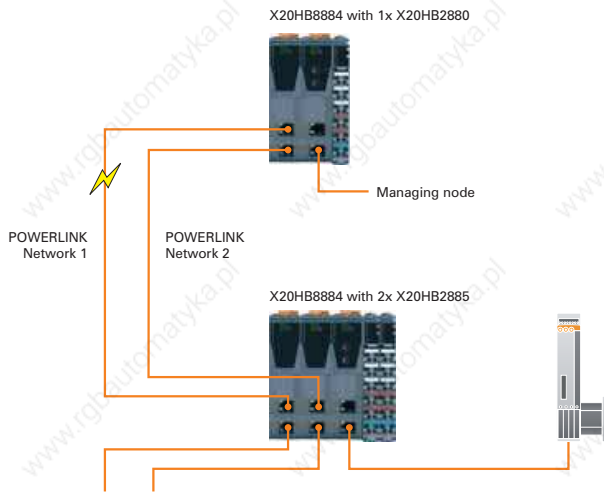

HB8884 with hub expansion modules

## System characteristics

### BC8084 bus controller

For connecting an X20 System, the link selector function is integrated in the X20 bus controller BC8084. The bus controller is connected to the POWERLINK network via external hubs.

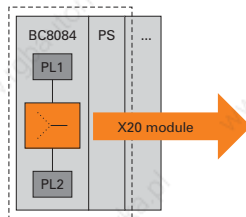

Function principle of the BC8084 bus controller

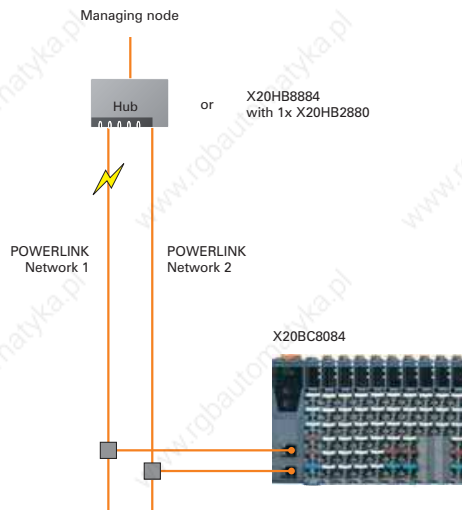

BC8084 with external hubs

### BC8084 with hub expansion modules

Expanding the BC8084 with two active X20HB2885 hub modules eliminates the need to connect external hubs. Two hot-swap capable modules are required so that the I/O can continue operating uninterrupted even when a hub is replaced. Additionally, a redundant supply voltage for the system can be easily implemented using two X20 supply modules.

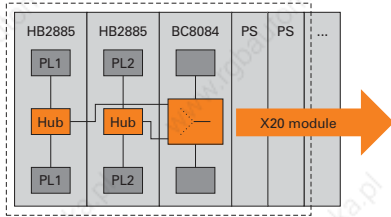

Function principle of the BC8084 bus controller with hub expansion modules

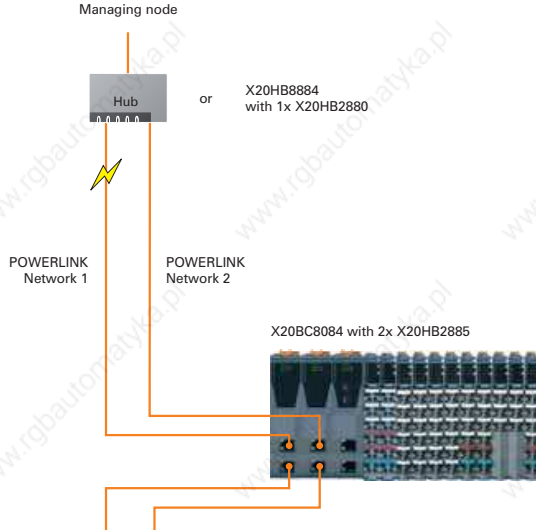

BC8084 with hub expansion modules

## System characteristics

### Redundancy

Redundancy is often only associated with process automation. However, this subject is much broader, as are the necessary solutions for redundancy tasks. While process automation often utilizes complete cable redundancy in networks, ring redundancy is used in machine manufacturing for dependable data transfer.

### Ring redundancy

Cost-effective wiring methods and ring redundancy often lead to a conflict of objectives. When taking a better look at the actual requirements, many tasks could be much better solved using partial ring topologies. POWERLINK offers these solutions.

Ring redundancy does not require additional devices. It is simply a configurable property of the B&R POWERLINK Manager with integrated hub. The two ports work either as hub hosting two branches of a POWERLINK network or a port is used for line looping to close the ring for redundant data transfer.

There is no limit to the number of times the ring itself can branch. That means that with just one additional cable, ring redundancy is possible up to the exact point in the network where it is needed. At the same time, the user retains all the freedom of branched cabling on the rest of the machine - redundancy has never been so economical.

- Switching speeds in the  $\mu\text{s}$  range
- Partial ring
- Cost-effective redundancy systems
- Configurable with software

### Classic ring redundancy

Classic ring redundancy incorporates every participant in the ring. In the event of a disruption (e.g. caused by line interruption), communication is supplied from both sides.

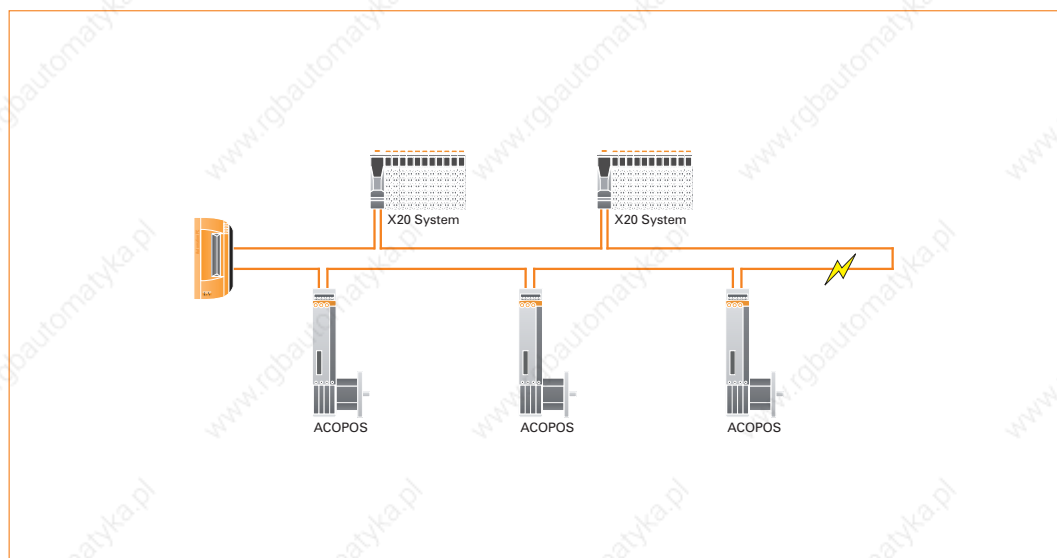

### Partial ring redundancy

Only one part of the topology is implemented as ring with redundancy properties. Hubs can be used to dock all standard topologies such as star, tree or line on the ring.

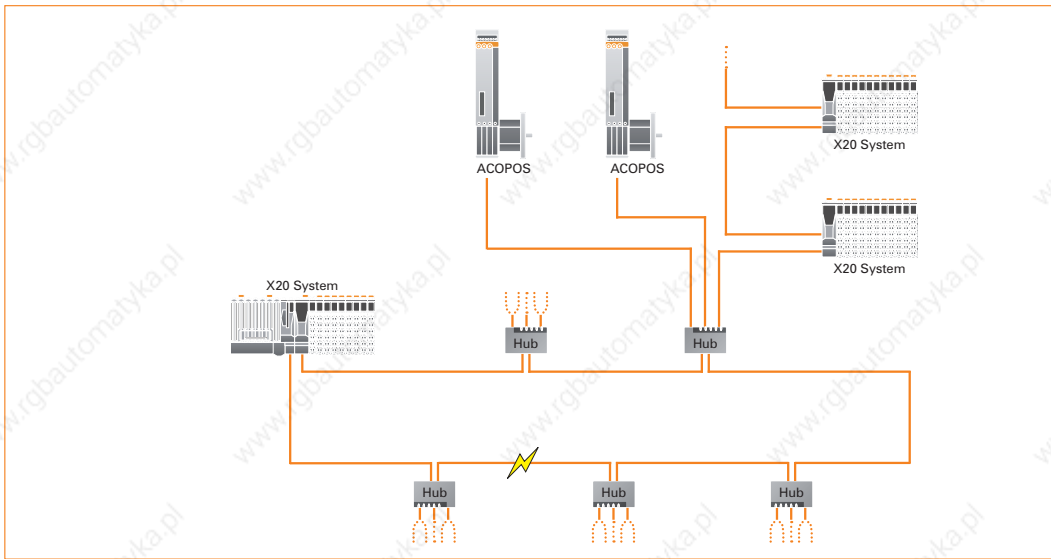

### Ring redundancy via slip ring

A practical example for the use of partial ring redundancy: Data transfer via a slip ring should be made redundant for reasons of operational safety. Redundancy on the actual rotating parts of the machine is not necessary. Ring cabling would actually be relatively difficult and uneconomical due to the required looping and inability for branching. That is why this part is implemented as tree with line structure in the branches.

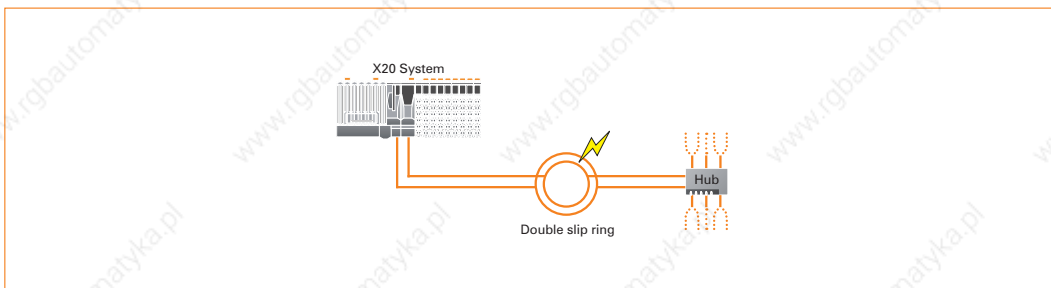

## System characteristics

### X20 System configuration

The X20 System is designed so that can be connected to either standard fieldbuses (with a bus controller) or the remote X2X Link backplane (with a bus receiver). The connection to the next station is made with a bus transmitter. Supply modules and I/O modules are placed between the bus receiver or bus controller and the bus transmitter as needed.

The power supply design for the X20 is explained in section "Mechanical and Electrical Configuration" (▮ 392).

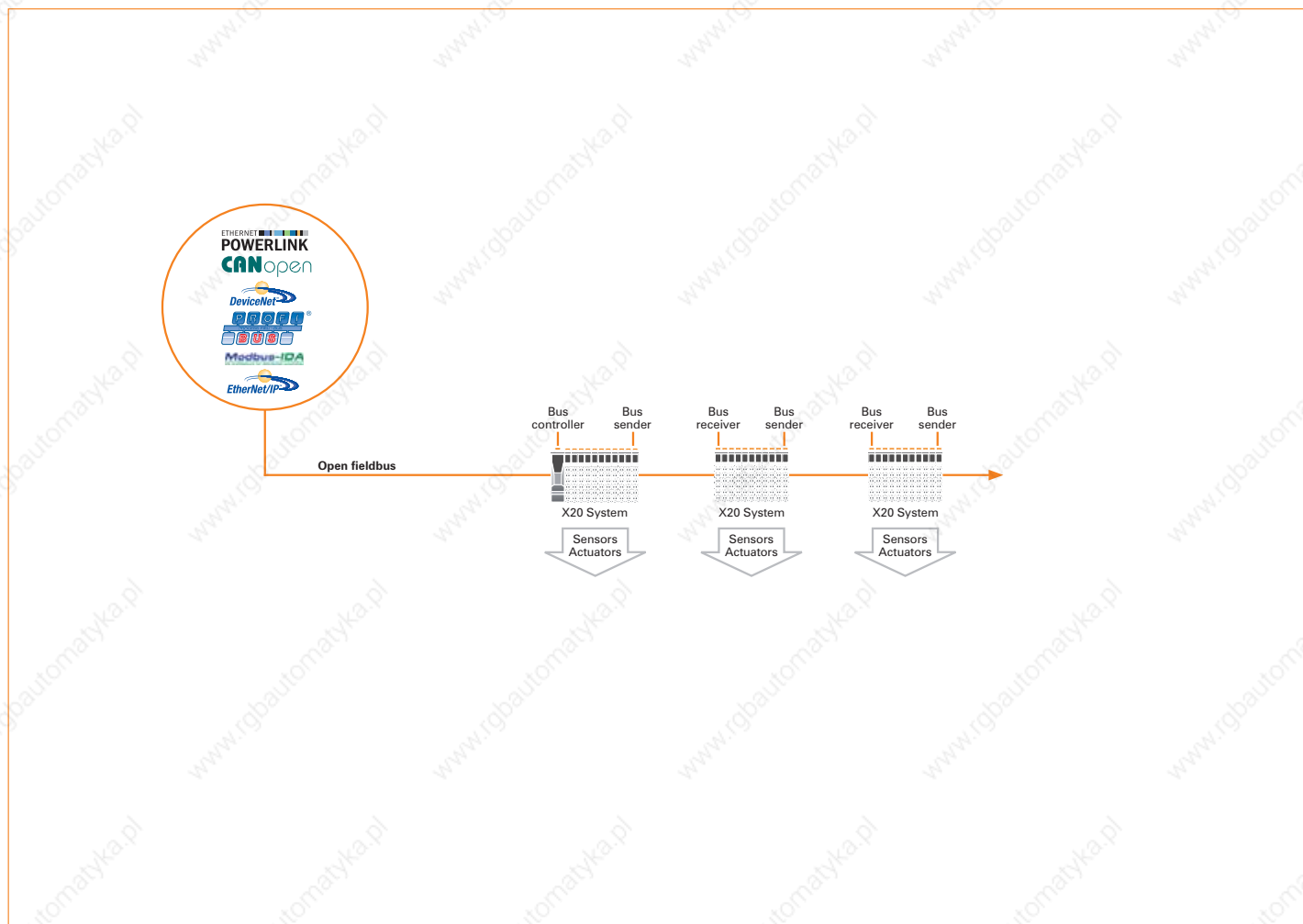



## System characteristics

### Fieldbus connection

Several bus controllers for standard fieldbus technologies like POWERLINK, DeviceNet, Profibus, CANopen, Modbus/TCP or EtherNet/IP are available to connect X20 modules to existing control systems. Fieldbus configurations transparently integrate the X20 System into the 3rd-party development environment.

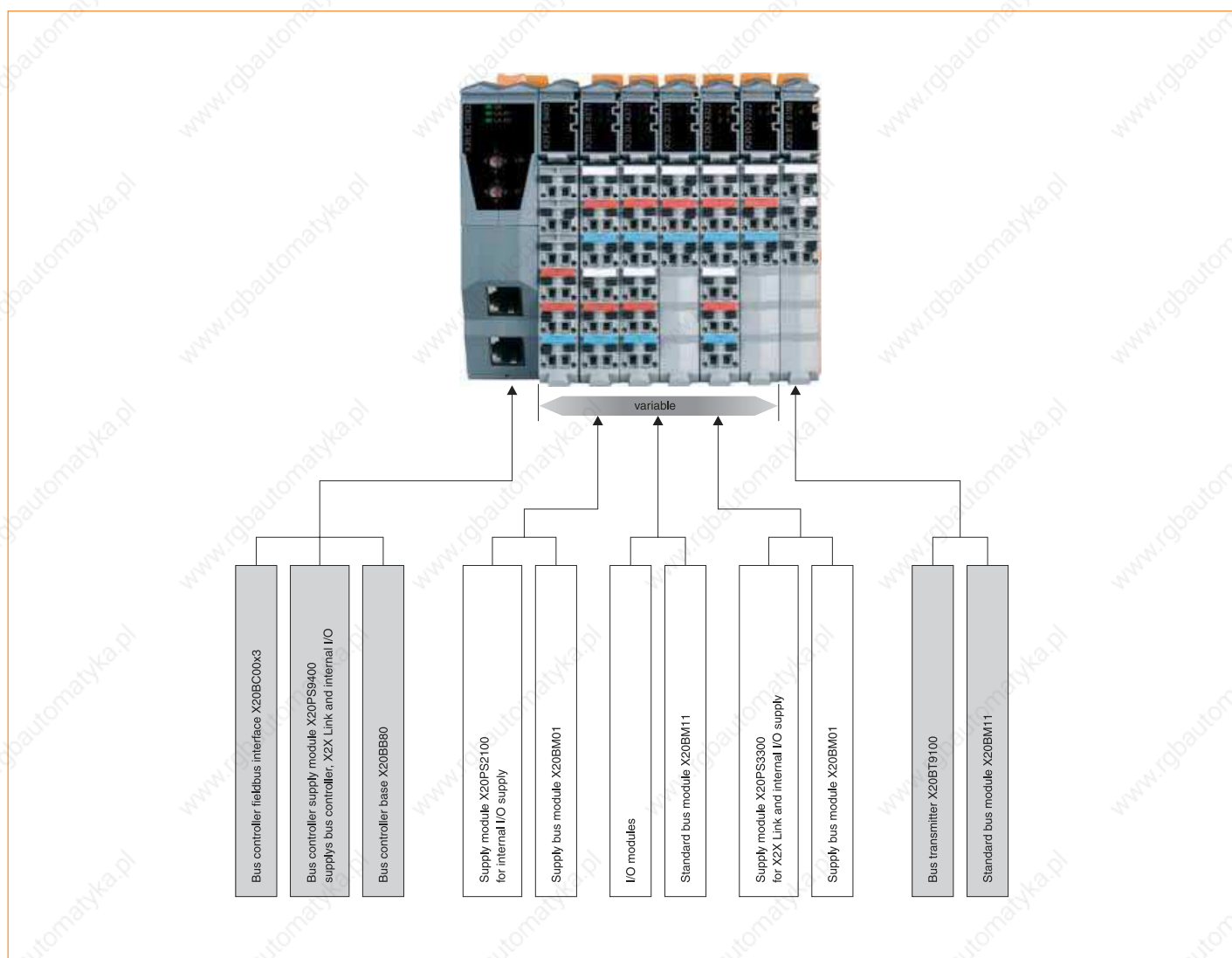

### Connection to X2X Link backplane

The bus receiver BR9300 is used to connect the X20 System directly to the remote X2X link backplane.

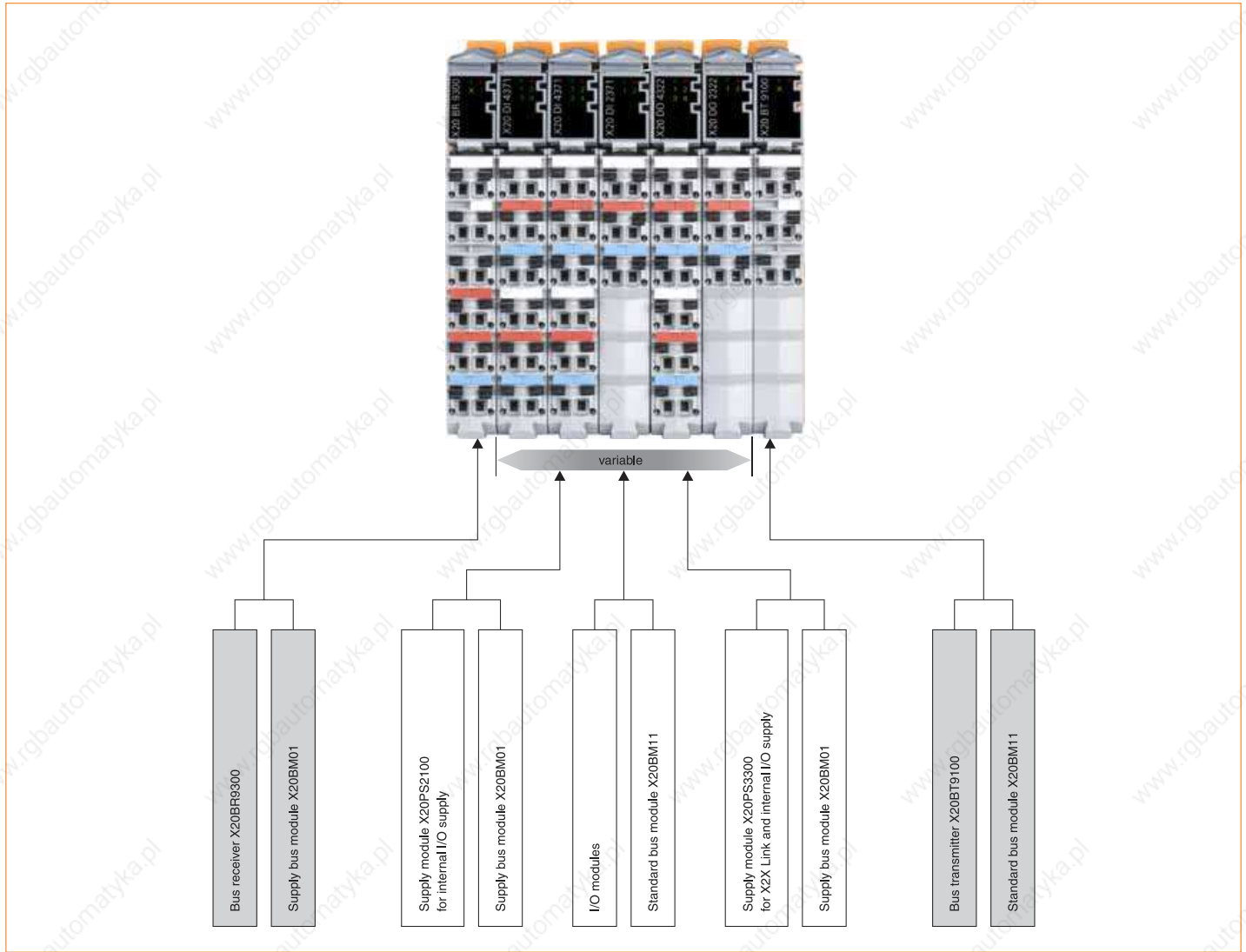

# Product overview

## Bus modules



Model number	Short description	
X20BM01	X20 supply bus module, internal I/O supply is isolated to the left	86
X20BM05	X20 supply bus module with node number switch, internal I/O supply is isolated to the left	87
X20BM11	X20 bus module, 24 V coded, internal I/O supply is interconnected	88
X20BM12	X20 bus module, 240 V coded, internal I/O supply is interconnected	89
X20BM15	X20 bus module with node number switches, internal I/O supply is interconnected	90
X20BM21	X20 bus module for double-width modules, internal I/O supply is isolated to the left	91
X20BM31	X20 bus module for double-width modules, internal I/O supply is interconnected	92

## Terminal blocks



Model number	Short description	
X20TB06	X20 terminal block, 6-pin, 24 V coded	94
X20TB12	X20 terminal block, 12-pin, 24 V coded	94
X20TB32	X20 terminal block, 12-pin, 240 V coded	95

## Selection table CPUs

	CP1483	CP1484 / CP3484	CP1485 / CP3485	CP1486 / CP3486
Processor	x86 100 comp.	Celeron 266 comp.	Celeron 400	Celeron 650
Fastest task class	1 ms	800 $\mu$ s	400 $\mu$ s	200 $\mu$ s
Cache	L1: 16 KB L2: -	L1: 2x 16 KB L2: -	L1: 2x 16 KB L2: 256 KB	L1: 2x 16 KB L2: 256 KB
RAM	32 MB SDRAM	32 MB SDRAM	64 MB SDRAM	64 MB SDRAM
User RAM	128 KB SRAM	1 MB SRAM	1 MB SRAM	1 MB SRAM
Remanent variables	32 KB	64 KB	256 KB	256 KB
Interface slots	1	1 / 3	1 / 3	1 / 3
Cooling	Fan-free	Fan-free	Fan-free	Fan-free derating / exchangeable fan
Processor support	Integrated I/O processor	Integrated I/O processor	Integrated I/O processor	Integrated I/O processor
Onboard interfaces	RS232, on X20 standard terminals, 115.2 kBit/s Ethernet, RJ45, 10/100 MBit/s POWERLINK, RJ45, 100 MBit/s 2x USB 1.1 1x X2X Link	RS232, on X20 standard terminals, 115.2 kBit/s Ethernet, RJ45, 10/100 MBit/s POWERLINK, RJ45, 100 MBit/s 2x USB 1.1 1x X2X Link	RS232, on X20 standard terminals, 115.2 kBit/s Ethernet, RJ45, 10/100 MBit/s POWERLINK, RJ45, 100 MBit/s 2x USB 1.1 1x X2X Link	RS232, on X20 standard terminals, 115.2 kBit/s Ethernet, RJ45, 10/100 MBit/s POWERLINK, RJ45, 100 MBit/s 2x USB 1.1 1x X2X Link
Dimensions (WxHxD) mm	150 x 99 x 85	150 / 200 x 99 x 85	150 / 200 x 99 x 85	150 / 200 x 99 x 85
Page	▣ 120	▣ 116 ▣ 112	▣ 108 ▣ 104	▣ 100 ▣ 96

## CPUs



Model number	Short description	
X20CP3486	X20 CPU, Celeron 650, 64 MB DRAM, 1 MB SRAM, exchangeable application memory: CompactFlash, 3 insert slots for X20IF modules, 2 USB interfaces, 1 RS232 interface, 1 Ethernet interface 10/100 Base T, 1 POWERLINK V1/V2 interface, order program memory separately.	▣ 96
X20CP1486	X20 CPU, Celeron 650, 64 MB DRAM, 1 MB SRAM, exchangeable application memory: CompactFlash, 1 insert slot for X20IF modules, 2 USB interfaces, 1 RS232 interface, 1 Ethernet interface 10/100 Base T, 1 POWERLINK V1/V2 interface, order program memory separately.	▣ 100
X20CP3485-1	X20 CPU, Celeron 400, 64 MB DRAM, 1 MB SRAM, exchangeable application memory: CompactFlash, 3 insert slots for X20IF modules, 2 USB interfaces, 1 RS232 interface, 1 Ethernet interface 10/100 Base T, 1 POWERLINK V1/V2 interface, order program memory separately.	▣ 104
X20CP1485-1	X20 CPU, Celeron 400, 64 MB DRAM, 1 MB SRAM, exchangeable application memory: CompactFlash, 1 insert slot for X20IF modules, 2 USB interfaces, 1 RS232 interface, 1 Ethernet interface 10/100 Base T, 1 POWERLINK V1/V2 interface, order program memory separately.	▣ 108
X20CP3484	X20 CPU, Celeron 266 compatible, 32 MB DRAM, 1 MB SRAM, exchangeable application memory: CompactFlash, 3 insert slots for X20IF modules, 2 USB interfaces, 1 RS232 interface, 1 Ethernet interface 10/100 Base T, 1 POWERLINK V1/V2 interface, order program memory separately.	▣ 112
X20CP1484	X20 CPU, Celeron 266 compatible, 32 MB DRAM, 1 MB SRAM, exchangeable application memory: CompactFlash, 1 insert slot for X20IF modules, 2 USB interfaces, 1 RS232 interface, 1 Ethernet interface 10/100 Base T, 1 POWERLINK V1/V2 interface, order program memory separately.	▣ 116
X20CP1483	X20 CPU, x86 100 MHz Intel compatible, 32 MB DRAM, 128 KB SRAM, exchangeable application memory: CompactFlash, 1 insert slot for X20IF modules, 2 USB interfaces, 1 RS232 interface, 1 Ethernet interface 10/100 Base-T, 1 POWERLINK V1/V2 interface, order program memory separately.	▣ 120

# Product overview

## Compact CPUs



Model number	Short description	
X20CP0292	X20 CPU, Compact CPU $\mu$ P 25, 750 KB SRAM, 3 MB FlashPROM, RS232 and CAN support corresponds to Compact CPU base, 1 Ethernet interface 100 Base-T	126
X20CP0291	X20 CPU, Compact CPU $\mu$ P 16, 100 KB SRAM, 1 MB FlashPROM, RS232 and CAN support corresponds to Compact CPU base, 1 Ethernet interface 100 Base-T	128
X20CP0201	X20 CPU, Compact CPU $\mu$ P 16, 100 KB SRAM, 1 MB FlashPROM, RS232 and CAN support corresponds to Compact CPU base	130

## Compact CPU - system modules



Model number	Short description	
X20BB22	X20 Compact CPU base, for Compact CPU and Compact CPU supply module, base for integrated RS232 interface, X20 connection, X20 end plates (left and right), X20AC0SL1/X20AC0SR1 included	132
X20BB27	X20 Compact CPU base, for Compact CPU and Compact CPU supply module, base for integrated RS232 and CAN interface, X20 connection, X20 end plates (left and right), X20AC0SL1/X20AC0SR1 included	133
X20PS9500	X20 supply module for Compact and fieldbus CPUs and internal I/O supply, X2X Link bus supply	134
X20PS9502	X20 supply module for Compact and fieldbus CPUs and internal I/O supply, X2X Link bus supply, supply feed not electrically isolated	138

## Fieldbus CPUs



Model number	Short description	
X20XC0292	X20 CPU, Fieldbus CPU $\mu$ P 25, 750 KB SRAM, 3 MB FlashPROM, RS232, CAN and IF support, corresponds to fieldbus Compact CPU base, 1 Ethernet interface 100 Base-T	142
X20XC0202	X20 CPU, Fieldbus CPU $\mu$ P 25, 750 KB SRAM, 3 MB FlashPROM, RS232, CAN and IF support, corresponds to Fieldbus CPU base	146
X20XC0201	X20 CPU, Fieldbus CPU $\mu$ P 16, 100 KB SRAM, 1 MB FlashPROM, RS232, CAN and IF support, corresponds to Fieldbus CPU base	148

## Fieldbus CPU system modules



Model number	Short description	
X20BB32	X20 Fieldbus CPU base, for Fieldbus CPU and Compact CPU supply module, base for integrated RS232 interface, slot for X20 interface module, X20 connection, X20 end plates (left and right), X20AC0SL1/X20AC0SR1 included	150
X20BB37	X20 Fieldbus CPU base, for Fieldbus CPU and Compact CPU supply module, base for integrated RS232 and CAN interface, slot for X20 interface module, X20 connection, X20 end plates (left and right), X20AC0SL1/X20AC0SR1 included	151
X20BB42	X20 Fieldbus CPU base, for Fieldbus CPU and Compact CPU supply module, base for integrated RS232 interface, 2x slots for X20 interface module, X20 connection, X20 end plates (left and right) X20AC0SL1/X20AC0SR1 included	152
X20BB47	X20 Fieldbus CPU base, for Fieldbus CPU and Compact CPU supply module, base for integrated RS232 and CAN interface, 2x slots for X20 interface modules, X20 connection, X20 end plates (left and right), X20AC0SL1/X20AC0SR1 included	153
X20PS9500	X20 supply module for Compact and fieldbus CPUs and internal I/O supply, X2X Link bus supply	134
X20PS9502	X20 supply module for Compact and fieldbus CPUs and internal I/O supply, X2X Link bus supply, Supply not electrically isolated	138
X20IF1020	X20 interface module, 1 RS232, max. 115.2 kBit/s, electrically isolated	189
X20IF1030	X20 interface module, 1 RS485/RS422, max. 115.2 kBit/s, electrically isolated	190
X20IF1061	X20 interface module, 1 Profibus DP master interface, max. 12 MBit/s, max. 3.5 KB input data and max. 3.5 KB output data, electrically isolated	191
X20IF1063	X20 interface module, 1 Profibus DP slave interface, max. 12 MBit/s, electrically isolated	192
X20IF1074	X20 IF interface module for SGC, 1CAN interface, max. 1MBit/s, electrically isolated, order 1x TB2105 terminal block separately.	154

## Bus controller



Model number	Short description	
X20BC0043	X20 bus controller fieldbus interface, 1 CANopen interface, status indicator LEDs, order 1x TB2105 terminal block separately.	156
X20BC0053	X20 bus controller fieldbus interface, 1 DeviceNet interface, status indicator LEDs, order 1x TB2105 terminal block separately.	158
X20BC0063	X20 bus controller fieldbus interface, 1 Profibus DP interface, status indicator LEDs, 9-pin DSUB connection	160
X20BC0073	X20 bus controller fieldbus interface, 1 CAN I/O interface, status indicator LEDs, order 1x TB2105 terminal block separately.	162
X20BC0083	X20 bus controller fieldbus interface, POWERLINK V1/V2 interface, integrated 2x hub, status indicator LEDs, 2x RJ45 connection	164
X20BC0087	X20 bus controller fieldbus interface, Modbus/TCP interface, integrated 2x switch, status indicator LEDs, 2x RJ45 connection	166
X20BC0088	X20 bus controller fieldbus interface, EtherNet/IP interface, LEDs for status display, 2x RJ45 connection	168

## Bus controller system modules



Model number	Short description	
X20BB80	X20 bus base, for X20 base module (BC, HB, etc.) and X20 supply module, X20 end plates (left and right) X20AC0SL1/X20AC0SR1 included	170
X20PS9400	X20 supply module for bus controller and internal I/O supply, X2X link bus supply	172
X20PS9402	X20 supply module for bus controller and internal I/O supply, X2X link bus supply, supply feed not electrically isolated	174

## Expandable bus controllers



Model number	Short description	
X20BC1083	X20 bus controller fieldbus interface, POWERLINK V1/V2 interface, integrated 2x hub, supports expansion with X20 status indicator LEDs, 2x RJ45 connection	178
X20BC8083	X20 bus controller fieldbus interface, POWERLINK V1/V2 interface, integrated 2x hub, supports expansion with X20 hub modules, status indicator LEDs, 2x RJ45 connection	180
X20BC8084	X20 bus controller fieldbus interface, POWERLINK V1/V2 interface, integrated Compact Link Selector, supports expansion with active X20 hub modules, status indicator LEDs, 2x RJ45 connection	182

## Expandable bus controller system modules



Model number	Short description	
X20BB81	X20 bus base with 1 expansion slot, for X20 base module (BC, HB, etc.) and an X20 auxiliary module (IF, HB, etc.) and X20 supply module, X20 end plates (left and right) X20AC0SL1/X20AC0SR1 included	184
X20BB82	X20 bus base with 2 expansion slots, for X20 base module (BC, HB, etc.) and two X20 auxiliary modules (IF, HB, etc.) and X20 supply module, X20 end plates (left and right), X20AC0SL1/X20AC0SR1 included	185
X20PS9400	X20 supply module for bus controller and internal I/O supply, X2X link bus supply	172
X20PS9402	X20 supply module for bus controller and internal I/O supply, X2X link bus supply, supply feed not electrically isolated	174
X20IF1091-1	X20 IF interface module for expandable bus controller, 1X2X Link master interface, electrically isolated, Order 1x TB704 terminal block separately.	186
X20HB2880	X20 hub expansion module, 2x hub connection, status indicator LEDs, 2x RJ45 connection	187
X20HB2885	X20 hub expansion module, integrated active 2x hub, status indicator LEDs, 2x RJ45 connection	188

## Product overview

### Selection table according to interfaces

	RS232	RS485/RS422	Profibus DP master	Profibus DP slave	CAN bus	X2X	Ethernet POWERLINK	
X20IF1020	1	-	-	-	-	-	-	189
X20IF1030	-	1	-	-	-	-	-	190
X20IF1061	-	-	1	-	-	-	-	191
X20IF1063	-	-	-	1	-	-	-	192
X20IF1072	-	-	-	-	1	-	-	193
X20IF1082	-	-	-	-	-	-	1	194
X20IF1091	-	-	-	-	-	1	-	195
X20IF2772	-	-	-	-	2	-	-	196
X20IF2792	-	-	-	-	1	1	-	197

### Communication in the X20 IF module

The IF modules are added to the X20 CPU as an application-specific interface expansion.



Model number	Short description	
X20IF1020	X20 interface module, 1 RS232, max. 115.2 kBit/s, electrically isolated	189
X20IF1030	X20 interface module, 1 RS485/RS422, max. 115.2 kBit/s, electrically isolated	190
X20IF1061	X20 interface module, 1 Profibus DP master interface, max. 12 MBit/s, max. 3.5 KB input data and max. 3.5 KB output data, electrically isolated	191
X20IF1063	X20 interface module, 1 Profibus DP slave interface, max. 12 MBit/s, electrically isolated	192
X20IF1072	X20 interface module, 1 CAN interface, max. 1 MBit/s, electrically isolated, order 1x TB2105 terminal block separately.	193
X20IF1082	X20 interface module, 1 POWERLINK V1/V2 interface, managing or controlled node, integrated 2x hub	194
X20IF1091	X20 interface module, 1 X2X Link master interface, electrically isolated, order 1x TB704 terminal block separately.	195
X20IF2772	X20 interface module, 2 CAN interfaces, max. 1 MBit/s, electrically isolated, order 2x TB2105 terminal block separately.	196
X20IF2792	X20 interface module, 1 CAN interface, max. 1 MBit/s, electrically isolated, 1 X2X Link master interface, electrically isolated, order 1x TB2105 and 1x TB704 terminal block separately.	197

### Communication in the X20 electronics module

The CS modules allow complex devices to be remotely connected to the X20 System via a serial interface.



Model number	Short description	
X20CS1011	X20 interface module, 1x Moeller SmartWire	198
X20CS1020	X20 interface module, 1x RS232, max. 115.2 kBit/s	200
X20CS1030	X20 interface module, 1x RS485/RS422, max. 250 kBit/s	202
X20CS1070	X20 interface module, 1x CAN, max. 1 MBit/s, object buffers in both send and receive directions	204
X20CS2770	X20 interface module, 2x CAN, max. 1 MBit/s, object buffers in both send and receive directions	206

## Bus receivers / transmitters



Model number	Short description	
X20BR9300	X20 bus receiver (X2X Link) with feed for internal I/O supply, and X2X Link bus supply	208
X20BT9100	X20 bus transmitter (X2X Link)	210
X20BT9400	X20 bus sender X2X Link, X2X Link supply for X67 modules, reverse polarity protection, short circuit protection, overload protection, parallel connection possible, redundancy operation possible	212

## Supply modules



Model number	Short description	
X20PS2100	X20 supply module for internal I/O supply	214
X20PS2110	X20 supply module for internal I/O supply, integrated microfuse	216
X20PS3300	X20 supply module for internal I/O supply, X2X link supply	218
X20PS3310	X20 supply module for internal I/O supply, X2X Link bus supply, integrated microfuse	220

## Dummy module



Model number	Short description	
X20ZF0000	Dummy X20 module (non-functional)	380

## X20 hub system



Model number	Short description	
X20BC8083	X20 bus controller fieldbus interface, POWERLINK V1/V2 interface, integrated 2x hub, supports expansion with X20 hub modules, status indicator LEDs, 2x RJ45 connection	180
X20HB8880	X20 hub base module, integrated 2x hub, status indicator LEDs, 2x RJ45 connection	382

# Product overview

## System modules for the X20 hub system



Model number	Short description	
X20BB80	X20 bus base, for X20 base module (BC, HB, etc.) and X20 supply module, X20 end plates (left and right) X20AC0SL1/X20AC0SR1 included	170
X20BB81	X20 bus base with 1 expansion slot, for X20 base module (BC, HB, etc.) and one X20 auxiliary module (IF, HB, etc.) and X20 supply module, X20 end plates (left and right), X20AC0SL1/X20AC0SR1 included	184
X20BB82	X20 bus base with 2 expansion slots, for X20 base module (BC, HB, etc.) and two X20 auxiliary modules (IF, HB, etc.) and X20 supply module, X20 end plates (left and right), X20AC0SL1/X20AC0SR1 included	185
X20HB2880	X20 hub expansion module, 2x hub connection, status indicator LEDs, 2x RJ45 connection	187
X20PS8002	X20 supply module for stand alone hub and compact link selector	384
X20PS9400	X20 supply module for bus controller and internal I/O supply, X2X link bus supply	172
X20PS9402	X20 supply module for bus controller and internal I/O supply, X2X link bus supply, supply feed not electrically isolated	174

## X20 redundancy system



Model number	Short description	
X20BC8084	X20 bus controller fieldbus interface, POWERLINK V1/V2 interface, integrated Compact Link Selector, supports expansion with active X20 hub modules, status indicator LEDs, 2x RJ45 connection	182
X20HB8884	X20 compact link selector, status indicator LEDs, 2x RJ45 connection, order bus base, supply module and terminal block separately!	386

## System modules for the X20 redundancy system



Model number	Short description	
X20BB80	X20 bus base, for X20 base module (BC, HB, etc.) and X20 supply module, X20 end plates (left and right) X20AC0SL1/X20AC0SR1 included	170
X20BB81	X20 bus base with 1 expansion slot, for X20 base module (BC, HB, etc.) and one X20 auxiliary module (IF, HB, etc.) and X20 supply module, X20 end plates (left and right), X20AC0SL1/X20AC0SR1 included	184
X20BB82	X20 bus base with 2 expansion slots, for X20 base module (BC, HB, etc.) and two X20 auxiliary modules (IF, HB, etc.) and X20 supply module, X20 end plates (left and right), X20AC0SL1/X20AC0SR1 included	185
X20HB2880	X20 hub expansion module, 2x hub connection, status indicator LEDs, 2x RJ45 connection	187
X20HB2885	X20 hub expansion module, integrated active 2x hub, status indicator LEDs, 2x RJ45 connection	188
X20PS8002	X20 supply module for stand alone hub and compact link selector	384
X20PS9400	X20 supply module for bus controller and internal I/O supply, X2X link bus supply	172
X20PS9402	X20 supply module for bus controller and internal I/O supply, X2X link bus supply, supply feed not electrically isolated	174

## Accessories

Short description	
Terminal locking clip, plain text cover, locking plate, etc.	388







# Product overview

## Digital input



Model number	Short description	
X20DI2371	X20 digital input module, 2 inputs, 24 VDC, sink, configurable input filter, 3-line connections	222
X20DI2372	X20 digital input module, 2 inputs, 24 VDC, source, configurable input filter, 3-line connections	224
X20DI2377	X20 digital input module, 2 inputs, 24 VDC, sink, configurable input filter, 2 event counters 50kHz	226
X20DI2653	X20 digital input module, 2 inputs, 100-240 VAC, 240 V coded, 3-line connections	228
X20DI4371	X20 digital input module, 4 inputs, 24 VDC, sink, configurable input filter, 3-line connections	230
X20DI4372	X20 digital input module, 4 inputs, 24 VDC, source, configurable input filter, 3-line connections	232
X20DI4653	X20 digital input module, 4 inputs, 100-240 VAC, 240 V coded, 2-line connections	234
X20DI4760	X20 digital input module, 4 NAMUR inputs, 8.05 VDC	236
X20DI6371	X20 digital input module, 6 inputs, 24 VDC, sink, configurable input filter, 2-line connections	238
X20DI6372	X20 digital input module, 6 inputs, 24 VDC, source, configurable input filter, 2-line connections	240
X20DI6553	X20 digital input module, 6 inputs, 100-120 VAC, 240 V coded, 1-line connections	242
X20DI8371	X20 digital input module, 8 inputs, 24 VDC, sink, configurable input filter, 1-line connections	244
X20DI9371	X20 digital input module, 12 inputs, 24 VDC, sink, configurable input filter, 1-line connections	246
X20DI9372	X20 digital input module, 12 inputs, 24 VDC, source, configurable input filter, 1-line connections	248

## Digital output



Model number	Short description	
X20DO2321	X20 digital output module, 2 outputs, 24 VDC, 0.5 A, sink, 3-line connections	250
X20DO2322	X20 digital output module, 2 outputs, 24 VDC, 0.5 A, source, 3-line connections	252
X20DO2623	X20 digital output module, 2 outputs, 100-240 VAC, 1.0 A, source, 240 V coded, 3-line connections	254
X20DO2649	X20 digital output module, 2 relays, change-over contacts, 230 VAC / 5 A, 30 VDC / 5 A	256
X20DO4321	X20 digital output module, 4 outputs, 24 VDC, 0.5 A, sink, 3-line connections	258
X20DO4322	X20 digital output module, 4 outputs, 24 VDC, 0.5 A, source, 3-line connections	260
X20DO4331	X20 digital output module, 4 outputs, 24 VDC, 2.0 A, sink, 3-line connections	262
X20DO4332	X20 digital output module, 4 outputs, 24 VDC, 2.0 A, source, 3-line connections	264
X20DO4529	X20 digital output module, 4 relays, change-over contacts, 115 VAC / 0.5 A, 30 VDC / 1 A	266
X20DO4623	X20 digital output module, 4 outputs, 100-240 VAC, 0.5 A, source, 240 V coded, 2-line connections	268
X20DO6321	X20 digital output module, 6 outputs, 24 VDC, 0.5 A, sink, 2-line connections	270
X20DO6322	X20 digital output module, 6 outputs, 24 VDC, 0.5 A, source, 2-line connections	272
X20DO6529	X20 digital output module, 6 relays, N.O. contacts, 115 VAC / 0.5 A, 30 VDC / 1 A	274
X20DO8322	X20 digital output module, 8 outputs, 24 VDC, 0.5 A, source, 1-line connections	276
X20DO8331	X20 digital output module, 8 outputs, 24 VDC, 2.0 A, sink, feed directly on module, 1-line connections	278
X20DO8332	X20 digital output module, 8 outputs, 24 VDC, 2.0 A, source, feed directly on module, 1-line connections	280
X20DO9321	X20 digital output module, 12 outputs, 24 VDC, 0.5 A, sink, 1-line connections	282
X20DO9322	X20 digital output module, 12 outputs, 24 VDC, 0.5 A, source, 1-line connections	284

## Digital inputs and outputs



Model number	Short description	
X20DM9324	X20 digital mixed module, 8 inputs, 24 VDC, sink, configurable input filter, 4 outputs, 24 VDC, 0.5 A, source, 1-wire connections	286

## Analog input



Model number	Short description	
X20AI1744	1 DMS input, 24-bit converter resolution, external filter modeling	288
X20AI2622	X20 analog input module, 2 inputs, $\pm 10$ V / 0 to 20 mA, 12-bit resolution, configurable input filter	290
X20AI2632	X20 analog input module, 2 inputs, $\pm 10$ V / 0 to 20 mA, 16-bit resolution, configurable input filter	292
X20AI2632-1	X20 analog input module, 2 inputs, $\pm 11$ V / 0 to 22 mA, 16-bit resolution, configurable input filter	294
X20AI4622	X20 analog input module, 4 inputs, $\pm 10$ V or 0 to 20 mA / 4 to 20 mA, 12-bit resolution, configurable input filter	296
X20AI4632	X20 analog input module, 4 inputs, $\pm 10$ V / 0 to 20 mA, 16-bit resolution, configurable input filter	298
X20AI4632-1	X20 analog input module, 4 inputs, $\pm 11$ V / 0 to 22 mA, 16-bit resolution, configurable input filter	300

## Analog output



Model number	Short description	
X20AO2622	X20 analog output module, 2 outputs, $\pm 10$ V / 0 to 20 mA, 12-bit resolution	302
X20AO2632	X20 analog output module, 2 outputs, $\pm 10$ V / 0 to 20 mA, 16-bit resolution	304
X20AO4622	X20 analog output module, 4 outputs, $\pm 10$ V / 0 to 20 mA, 12-bit resolution	306
X20AO4632	X20 analog output module, 4 outputs, $\pm 10$ V / 0 to 20 mA, 16-bit resolution	308

# Product overview

## Temperature



Model number	Short description	
X20AT2222	X20 temperature input module, 2 resistance measurement inputs, PT100, PT1000, resolution 0.1 K, 3-line connections	310
X20AT2311	X20 temperature input module, 2 resistance measurement inputs, PT100, resolution 1.0 mK, 4-line connections	314
X20AT2402	X20 temperature input module, 2 thermocouple inputs, type J,K,N,S, resolution 0.1 K	316
X20AT4222	X20 temperature input module, 4 resistance measurement inputs, PT100, PT1000, resolution 0.1 K, 3-line connections	312
X20AT6402	X20 temperature input module, 6 thermocouple inputs, type J,K,N,S, resolution 0.1 K	318

## Motor module



Model number	Short description	
X20MM2436	X20 PWM motor bridge module, 24 - 39 VDC $\pm$ 25% module supply, 2x PWM motor bridges, 3 A, 4x digital inputs can be configured as incremental encoders	320
X20MM4456	X20 PWM motor bridge module, 24 - 48 VDC $\pm$ 25% module supply, 4x PWM motor bridges, 6 A, 4x 4 digital inputs can be configured as incremental encoders	322
X20SM1426	X20 stepper motor module, 24 VDC supply, 1x motor connection, 1 A, 1.2 A max., 4x digital input 24 VDC, sink, can be used as incremental encoders	324
X20SM1436	X20 stepper motor module, 24 - 39 VDC $\pm$ 25% supply, 1x motor connection, 3 A, 3.5 A max., 4x digital input 24 VDC, sink, can be used as incremental encoders	326

## Other functions



Model number	Short description	
X20CM0985	X20 digital/analog mixed module, multi-measurement transformer/synchronization module, 5x DO, 24 VDC, 0.5 A, source, 1 relay 0.5 A, 8x AI $\pm$ 480 V/120 V, 16-bit converter resolution, 3x AI $\pm$ 5 A/1 A, 16-bit converter resolution	328
X20CM1201	X20 combination module, 1x AB incremental encoder 24 V, 4x digital inputs 24 V, 4 channels, 24 V can be configured as input or output, flexible digital controller logic	332
X20CM8281	X20 universal mixed module, 4 outputs, 24 VDC, sink, 1-line connections, 2 digital outputs, 0.5 A, source, 1-line connections, 1 analog input, $\pm$ 10 V or 0 to 20 mA / 4 to 20 mA, 12-bit resolution, 1 analog output, $\pm$ 10 V / 0 to 20 mA, 12-bit resolution, 2 counters as event counters or gate measurement	334
X20CM8323	X20 PWM module, 8 digital outputs for switching electromechanical loads, 0.6 A continuous current, 2 A peak current, current monitoring, switching time detection	338
X20PD0011	X20 potential distributor, 12x GND, integrated microfuse	340
X20PD0012	X20 potential distributor, 12x 24 VDC, integrated microfuse	342
X20PD0016	X20 potential distributor, 5x GND, 5x 24 VDC, each with 1x potential-free feed, integrated microfuse	344
X20PD2113	X20 potential distributor, 6x GND, 6x 24 VDC, with feed possibility, integrated microfuse	346
X20PS4951	X20 supply module for potentiometers, 4x $\pm$ 10 V potentiometer supply	348

## Counting



Model number	Short description	
X20CM1941	X20 resolver module, 14-bit resolver input, up to 12-bit ABR output	350
X20DC1196	X20 digital counter module, 1 channel ABR, 5 V, 250 kHz input frequency, 4x evaluation	352
X20DC1198	X20 digital counter module, 1 channel SSI, 5 V, 1 MBit/s, 32-bit	354
X20DC1396	X20 digital counter module, 1 channel ABR, 24 V, 100 kHz input frequency, 4x evaluation	356
X20DC1398	X20 digital counter module, 1 channel SSI, 24 V, 125 MBit/s, 32-bit	358
X20DC2190	X20 digital counter module, ultrasonic transducer module, interfaces: EP Start/Stop, DPI/IP, 2 transducer rods, 4 path evaluation	360
X20DC2396	X20 digital counter module, 2 channel ABR, 24 V, 100 kHz input frequency, 4x evaluation	362
X20DC2398	X20 digital counter module, 2 channel SSI, 24 V, 125 MBit/s, 32-bit	364
X20DC2395	X20 digital counter module, 1x SSI absolute encoder, 24 V, 1x ABR incremental encoder, 24 V, 2x AB incremental encoder, 24 V, 4x event counter or 2x PWM, local time measurement functions	366
X20DC4395	X20 digital counter module, 2x SSI absolute encoder, 24 V, 2x ABR incremental encoder, 24 V, 4x AB incremental encoder, 24 V, 8x event counter or 4x PWM, local time measurement functions	370
X20DS1119	X20 multi-function digital signal processor, 3 digital 5 V (symmetric) channels, can be configured as inputs or outputs, 2 digital 24 V (asymmetric) input channels, up to 2 event counters, universal counter pair as A/B counter or up/down counter, linear movement generator (A/B; direction/frequency) with one reference pulse, SSI absolute encoder	374
X20DS1319	X20 multi-function digital signal processor, 4 digital input channels, 4 digital channels that can be configured as inputs or outputs, up to 2 event counters, universal counter pair as A/B counter or up/down counter, linear movement generator (A/B; direction/frequency) with up to 2 reference pulses, SSI absolute encoder	378

## Product overview

### Integrated safety technology

The addition of the Integrated Safety Technology programs to the X20 System help it satisfy all requirements of safety-related applications.

The Integrated Safety Technology products include:

- Safe digital input modules
- Safe digital output modules
- SafeLOGIC

The following pages contain a product overview of all X20 safety modules. More detailed information can be found in chapter 4, Integrated Safety Technology.





# Product overview

## Bus modules



Model number	Short description	
X20BM33	X20 bus module, safety coded, internal I/O supply is interconnected	546

## Terminal blocks



Model number	Short description	
X20TB52	X20 terminal block, 12-pin, safety coded	547

## Safe CPUs



Model number	Short description	
X20SL8000	X20 SafeLOGIC, Safety CPU standard, exchangeable User RAM: memory key, 1 POWERLINK V2 interface, Controlled Node, integrated 2x hub, incl. supply module, terminal block X20TB52, X20 locking plate (right), order memory key separately.	548
X20SL8001	X20 SafeLOGIC, Safety CPU plus, exchangeable User RAM: memory key, 1 POWERLINK V2 interface, Controlled Node, integrated 2x hub, incl. supply module, terminal block X20TB52, X20 locking plate (right), order memory key separately.	550

## Safe digital input



Model number	Short description	
X20SI2100	X20 safe digital input module, 2 failsafe inputs, 2 pulse outputs, 24 VDC, configurable input filters	552
X20SI4100	X20 safe digital input module, 4 failsafe inputs, 4 pulse outputs, 24 VDC, configurable input filters	554

## Safe digital output



Model number	Short description	
X20SO2110	X20 safe digital output module, 2 failsafe semiconductor outputs with current monitoring, 24 VDC, 0.5 A	556
X20SO2120	X20 safe digital output module, 2 failsafe semiconductor outputs with current monitoring, 24 VDC, 2 A	558
X20SO4110	X20 safe digital output module, 4 failsafe semiconductor outputs with current monitoring, 24 VDC, 0.5 A	560
X20SO4120	X20 safe digital output module, 4 failsafe semiconductor outputs with current monitoring, 24 VDC, 2 A	562

## Accessories



Model number	Short description	
X20MK0201	X20 memory key, 2 MB	564
X20MK0203	X20 memory key, 8 MB	564

# Bus module BM01



The BM01 bus module is the base for all X20 supply modules.

- Base for all X20 supply modules
- For creating electrical potential groups
- The internal I/O supply is interrupted to the left

<b>Short description</b>	<b>X20BM01</b>
Bus module	Supply bus module, internal I/O supply is isolated to the left
<b>General information</b>	<b>X20BM01</b>
Power consumption	
Bus	0.13 W
I/O internal	-
Certification	CE, C-UL-US, GOST-R
<b>Operational conditions</b>	<b>X20BM01</b>
Operating temperature	
Horizontal installation	0°C to +55°C
Vertical installation	0°C to +50°C
Relative humidity	5 to 95%, non-condensing
Mounting orientation	Horizontal or vertical
Installation at altitudes above sea level	
0 - 2000 m	No derating
>2000 m	Reduction of ambient temperature by 0.5°C per 100 m
Protection type	IP20
<b>Storage and transport conditions</b>	<b>X20BM01</b>
Temperature	-25°C to +70°C
Relative humidity	5 to 95%, non-condensing
<b>Mechanical characteristics</b>	<b>X20BM01</b>
Spacing	12.5 <sup>+0.2</sup> mm

## Potential control

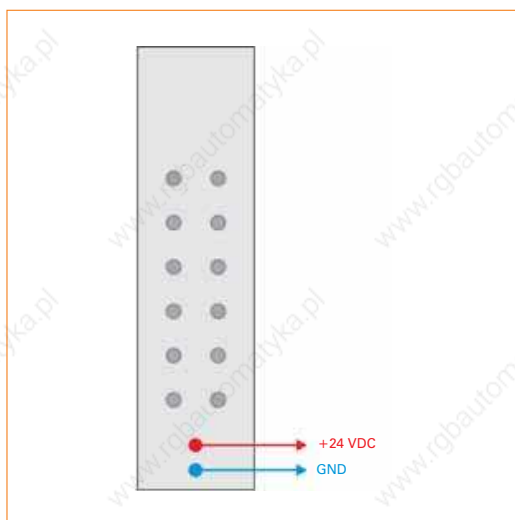

# Bus module BM05



The BM05 bus module is the base for all X20 supply modules. This bus module is also used to determine a unique address using node number switches.

- The BM05 is the base for all X20 supply modules.
- For creating electrical potential groups
- The internal I/O supply is isolated to the left
- Manual node number assignment
- Independent of electronics module
- Manual and automatic addressing can be mixed as desired

<b>Short description</b>	<b>X20BM05</b>
Bus module	Supply bus module, internal I/O supply is isolated to the left, manual node number assignment
<b>General information</b>	<b>X20BM05</b>
Power consumption	
Bus	0.13 W
I/O internal	-
Certification	CE, C-UL-US (in development), GOST-R
<b>Operational conditions</b>	<b>X20BM05</b>
Operating temperature	
Horizontal installation	0°C to +55°C
Vertical installation	0°C to +50°C
Relative humidity	5 to 95%, non-condensing
Mounting orientation	Horizontal or vertical
Installation at altitudes above sea level	
0 - 2000 m	No derating
>2000 m	Reduction of ambient temperature by 0.5°C per 100 m
Protection type	IP20
<b>Storage and transport conditions</b>	<b>X20BM05</b>
Temperature	-25°C to +70°C
Relative humidity	5 to 95%, non-condensing
<b>Mechanical characteristics</b>	<b>X20BM05</b>
Spacing	12.5 <sup>+0.2</sup> mm

## Potential control

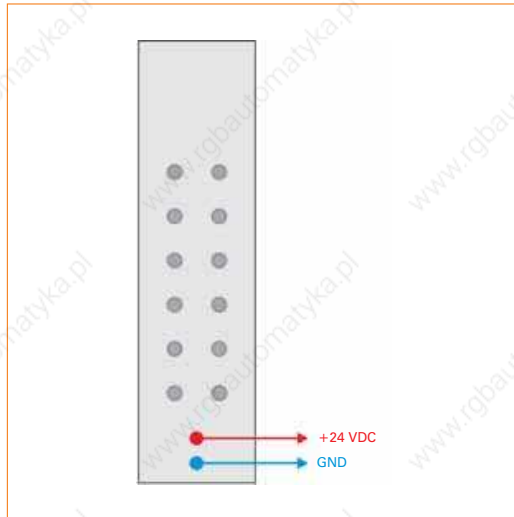

# Bus module BM11



The BM11 bus module serves as the base for all 24 VDC X20 I/O modules.

- Bus module for 24 VDC I/O modules
- The internal I/O supply is interconnected

<b>Short description</b>	<b>X20BM11</b>
Bus module	Bus module for 24 VDC I/O modules, the internal I/O supply is interconnected
<b>General information</b>	<b>X20BM11</b>
Power consumption	
Bus	0.13 W
I/O internal	-
Certification	CE, C-UL-US, GOST-R
<b>Operational conditions</b>	<b>X20BM11</b>
Operating temperature	
Horizontal installation	0°C to +55°C
Vertical installation	0°C to +50°C
Relative humidity	5 to 95%, non-condensing
Mounting orientation	Horizontal or vertical
Installation at altitudes above sea level	
0 - 2000 m	No derating
>2000 m	Reduction of ambient temperature by 0.5°C per 100 m
Protection type	IP20
<b>Storage and transport conditions</b>	<b>X20BM11</b>
Temperature	-25°C to +70°C
Relative humidity	5 to 95%, non-condensing
<b>Mechanical characteristics</b>	<b>X20BM11</b>
Spacing	12.5 <sup>+0.2</sup> mm

## Potential control

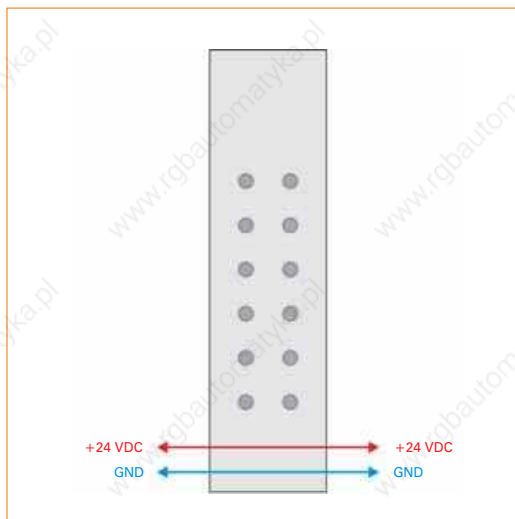

# Bus module BM12



The BM12 bus module serves as the base for all 240 VAC X20 I/O modules. The internal I/O supply is interconnected.

- Bus module for 240 VAC I/O modules
- The internal I/O supply is interconnected
- Special color
- 240 V coding for bus module, electronic module and terminal block

<b>Short description</b>	<b>X20BM12</b>
Bus module	Bus module for 240 VAC I/O modules, the internal I/O supply is interconnected
<b>General information</b>	<b>X20BM12</b>
Power consumption	
Bus	0.13 W
I/O internal	-
Certification	CE, C-UL-US (in development), GOST-R
<b>Operational conditions</b>	<b>X20BM12</b>
Operating temperature	
Horizontal installation	0°C to +55°C
Vertical installation	0°C to +50°C
Relative humidity	5 to 95%, non-condensing
Mounting orientation	Horizontal or vertical
Installation at altitudes above sea level	
0 - 2000 m	No derating
>2000 m	Reduction of ambient temperature by 0.5°C per 100 m
Protection type	IP20
<b>Storage and transport conditions</b>	<b>X20BM12</b>
Temperature	-25°C to +70°C
Relative humidity	5 to 95%, non-condensing
<b>Mechanical characteristics</b>	<b>X20BM12</b>
Spacing	12.5 <sup>+0.2</sup> mm

## Potential control

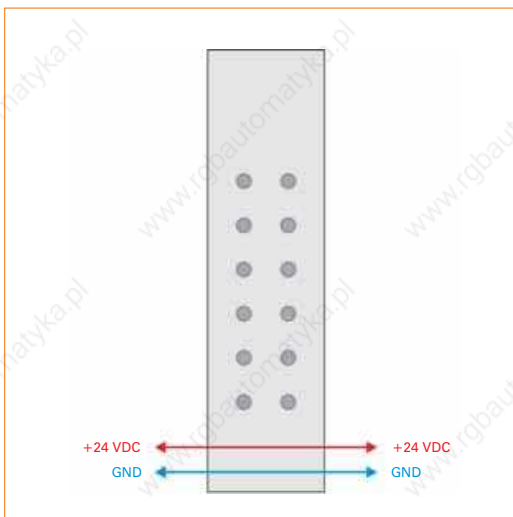

# Bus module BM15



The BM15 bus module serves as the base for all 24 VDC X20 I/O modules. This bus module is also used to determine a unique address using node number switches.

- The BM15 is the base for all X20 24 VDC I/O modules.
- The internal I/O supply is interconnected
- Manual node number assignment
- Independent of electronics module
- Manual and automatic addressing can be mixed as desired

<b>Short description</b>	<b>X20BM15</b>
Bus module	Bus module for 24 VDC I/O modules, the internal I/O supply is interconnected, manual node number assignment
<b>General information</b>	<b>X20BM15</b>
Power consumption	
Bus	0.13 W
I/O internal	-
Certification	CE, C-UL-US (in development), GOST-R
<b>Operational conditions</b>	<b>X20BM15</b>
Operating temperature	
Horizontal installation	0°C to +55°C
Vertical installation	0°C to +50°C
Relative humidity	5 to 95%, non-condensing
Mounting orientation	Horizontal or vertical
Installation at altitudes above sea level	
0 - 2000 m	No derating
>2000 m	Reduction of ambient temperature by 0.5°C per 100 m
Protection type	IP20
<b>Storage and transport conditions</b>	<b>X20BM15</b>
Temperature	-25°C to +70°C
Relative humidity	5 to 95%, non-condensing
<b>Mechanical characteristics</b>	<b>X20BM15</b>
Spacing	12.5 <sup>+0.2</sup> mm

## Potential control

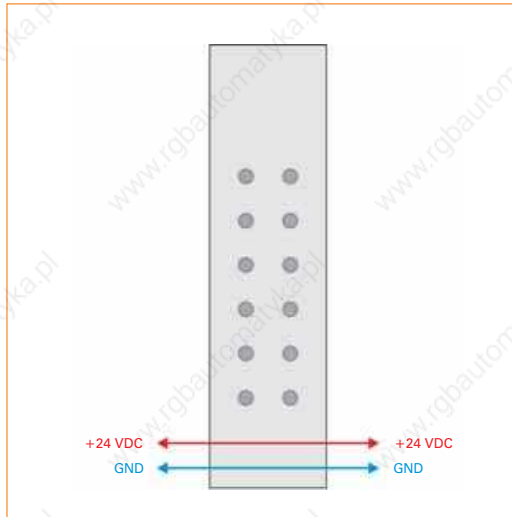

# Bus module BM21



The BM21 bus module serves as a base for all double-width X20 I/O modules. The internal I/O supply is isolated to the left. This allows the BM21 bus module to be used to set up a separate potential group, if the BT9100 bus transmitter is used for the supply.

- For creating electrical potential groups
- The internal I/O supply is isolated to the left

<b>Short description</b>	<b>X20BM21</b>
Bus module	Double-width bus module, internal I/O supply is isolated to the left
<b>General information</b>	<b>X20BM21</b>
Power consumption	
Bus	0.13 W
I/O internal	-
Certification	CE, C-UL-US, GOST-R
<b>Operational conditions</b>	<b>X20BM21</b>
Operating temperature	
Horizontal installation	0°C to +55°C
Vertical installation	0°C to +50°C
Relative humidity	5 to 95%, non-condensing
Mounting orientation	Horizontal or vertical
Installation at altitudes above sea level	
0 - 2000 m	No derating
>2000 m	Reduction of ambient temperature by 0.5°C per 100 m
Protection type	IP20
<b>Storage and transport conditions</b>	<b>X20BM21</b>
Temperature	-25°C to +70°C
Relative humidity	5 to 95%, non-condensing
<b>Mechanical characteristics</b>	<b>X20BM21</b>
Spacing	25 <sup>+0.2</sup> mm

## Potential control

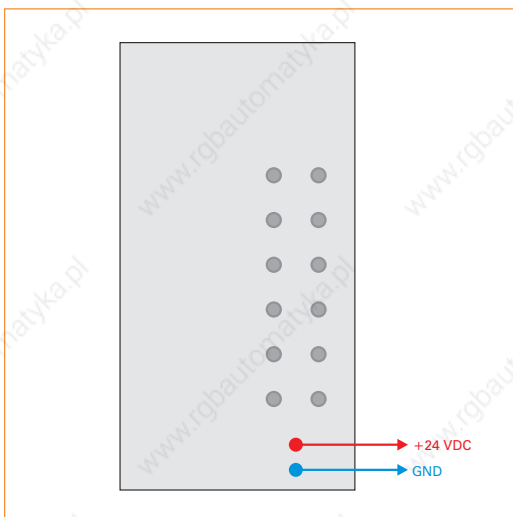

# Bus module BM31



The BM31 bus module serves as a base for all double-width X20 I/O modules. The internal I/O supply is interconnected.

- Bus module for double-width I/O modules
- The internal I/O supply is interconnected

<b>Short description</b>	<b>X20BM31</b>
Bus module	Double-width bus module, the internal I/O supply is interconnected
<b>General information</b>	<b>X20BM31</b>
Power consumption	
Bus	0.13 W
I/O internal	-
Certification	CE, C-UL-US, GOST-R
<b>Operational conditions</b>	<b>X20BM31</b>
Operating temperature	
Horizontal installation	0°C to +55°C
Vertical installation	0°C to +50°C
Relative humidity	5 to 95%, non-condensing
Mounting orientation	Horizontal or vertical
Installation at altitudes above sea level	
0 - 2000 m	No derating
>2000 m	Reduction of ambient temperature by 0.5°C per 100 m
Protection type	IP20
<b>Storage and transport conditions</b>	<b>X20BM31</b>
Temperature	-25°C to +70°C
Relative humidity	5 to 95%, non-condensing
<b>Mechanical characteristics</b>	<b>X20BM31</b>
Spacing	25 <sup>+0.2</sup> mm

## Potential control

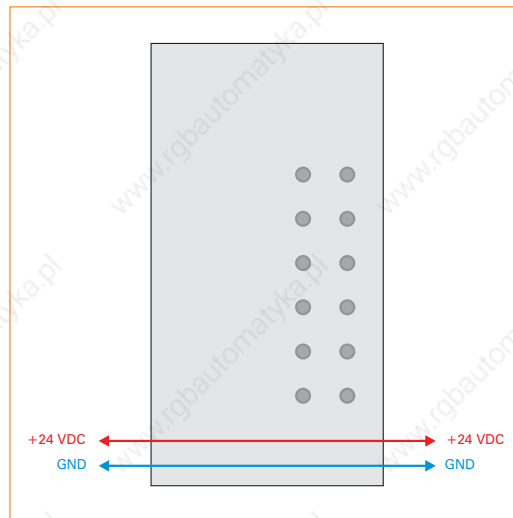



## 6/12-pin terminal block TB06/TB12

The X20 24 VDC modules are wired using the TB06 and TB12 terminal blocks.

- Tool-free wiring thanks to push-in construction
- Simple wire release using lever
- Identification option for each terminal
- Plain text labeling also possible
- Test access for standard probes
- Can be customer-coded



Short description	X20TB06	X20TB12
Terminal block	6-pin	12-pin
Terminal block	X20TB06	X20TB12
Type of terminal	Push-in terminal	Push-in terminal
Distance between contacts		
Left - right	4.2 mm	4.2 mm
Above - below	10.96 mm	10.96 mm
Contact resistance	≤5 mΩ	≤5 mΩ
Rated voltage	230 VAC	230 VAC
Rated Current <sup>1)</sup>	10 A / contact	10 A / contact
Connection cross section		
Solid wire line	0.08 mm <sup>2</sup> - 2.5 mm <sup>2</sup> / AWG 28 - 14	0.08 mm <sup>2</sup> - 2.5 mm <sup>2</sup> / AWG 28 - 14
Fine wire line	0.25 mm <sup>2</sup> - 2.5 mm <sup>2</sup> / AWG 24 - 14	0.25 mm <sup>2</sup> - 2.5 mm <sup>2</sup> / AWG 24 - 14
With wire tip sleeves	0.25 mm <sup>2</sup> - 1.5 mm <sup>2</sup> / AWG 24 - 16	0.25 mm <sup>2</sup> - 1.5 mm <sup>2</sup> / AWG 24 - 16
	Up to 2x 0.75 mm <sup>2</sup> for double wire tip sleeves	Up to 2x 0.75 mm <sup>2</sup> for double wire tip sleeves
Cable type	Copper wires only (no aluminum wires!)	Copper wires only (no aluminum wires!)

<sup>1)</sup> The respective limit data for the I/O modules must be taken into consideration.

## 12-pin terminal block TB32

The X20 240 VAC modules are wired using TB32 terminal blocks.

- Tool-free wiring with push-in technology
- Simple wire release using lever
- Ability to label each terminal
- Plain text labeling also possible
- Test access for standard probes
- Can be customer-coded
- Special color
- 240 V coding



<b>Short description</b>	<b>X20TB32</b>
Terminal block	12-pin terminal block for 240 VAC I/O modules
<b>Terminal block</b>	<b>X20TB32</b>
Type of terminal	Push-in terminal
Distance between contacts	
Left - right	4.2 mm
Above - below	10.96 mm
Contact resistance	≤5 mΩ
Rated voltage	230 VAC
Rated Current <sup>1)</sup>	10 A / contact
Connection cross section	
Solid wire line	0.08 mm <sup>2</sup> - 2.5 mm <sup>2</sup> / AWG 28 - 14
Fine wire line	0.25 mm <sup>2</sup> - 2.5 mm <sup>2</sup> / AWG 24 - 14
With wire tip sleeves	0.25 mm <sup>2</sup> - 1.5 mm <sup>2</sup> / AWG 24 - 16
	Up to 2x 0.75 mm <sup>2</sup> for double wire tip sleeves
Cable type	Copper wires only (no aluminum wires!)

1) The respective limit data for the I/O modules must be taken into consideration.

# CPU CP3486

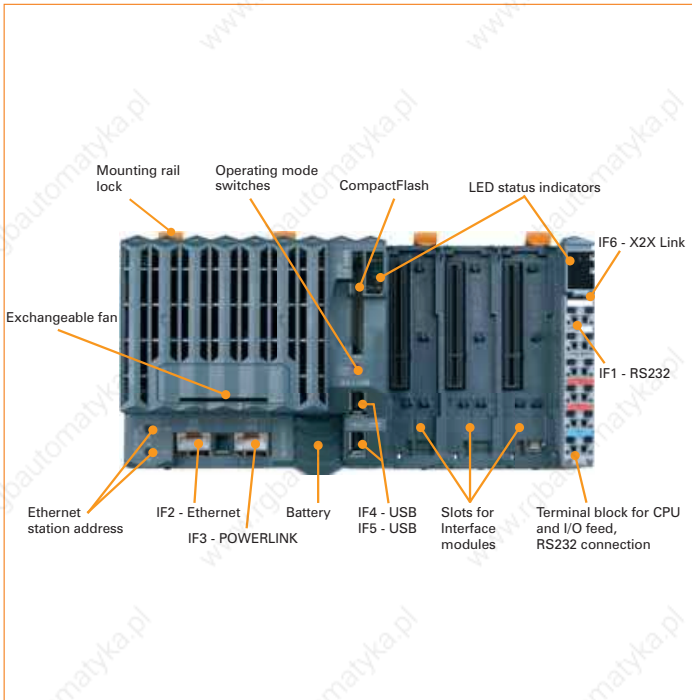

The CP3486 is a high-performance CPU for the X20 System. This CPU can be used anywhere from high-end applications in machine manufacturing to demanding tasks in process control.

Ethernet and USB are onboard. In addition, the CPU has a POWERLINK V1/V2 connection for real-time communication. In addition, there are three multi-purpose slots for additional interface modules.

- Intel Celeron 650 Performance with additional I/O processor
- Ethernet, POWERLINK V1/V2 and USB onboard
- 3 slots for modular interface expansion
- Compact Flash as removable application memory
- Fan can be exchanged from the outside, tool-free
- Extremely compact

## ETHERNET POWERLINK



<b>Short description</b>	<b>X20CP3486</b>
System module	CPU
Processor	Celeron 650
Interfaces	1x RS232, 1x Ethernet, 1x POWERLINK V1/V2, 2x USB, 1x X2X Link
<b>Controller</b>	<b>X20CP3486</b>
Fastest task class cycle time	200 $\mu$ s
Typical instruction cycle time	0.01 $\mu$ s
L1 cache for data and program code	2x 16 KB
L2 cache	256 KB
Standard memory	
Working memory (SDRAM)	64 MB SDRAM
User RAM (SRAM)	1 MB SRAM
Remanent variables	256 KB
FPU	Yes
Integrated I/O processor	Processes I/O data points in the background
Data buffering	
Lithium battery	At least 3 years
Battery monitoring	Yes
CompactFlash slot	1
Real-time clock	Nonvolatile memory, resolution 1 second
Modular interface slots	3

<b>Interfaces</b>		<b>X20CP3486</b>
<b>Interface IF1</b>		
Type		RS232
Design		Contact via 12-pin terminal block TB12
Maximum transfer rate		115.2 kBit/s
<b>Interface IF2</b>		
Type		Ethernet
Design		Shielded RJ45 port
Transfer rate		10/100 MBit/s
Cable length		Max. 100 m between two stations (segment length)
<b>Interface IF3</b>		
Fieldbus		POWERLINK V1/V2
Type		100 Base-T (ANSI/IEEE 802.3)
Design		Shielded RJ45 port
Transfer rate		100 MBit/s
Cable length		Max. 100 m between two stations (segment length)
<b>Interfaces IF4 and IF5</b>		
		USB Rev. 1.1
<b>IF6 interface</b>		
		X2X Link
<b>CPU and X2X Link supply</b>		
Input voltage		24 VDC (-15% / +20%)
Input current		Max. 2.2 A
Reverse polarity protection		Yes
Fuse		Integrated, cannot be exchanged
<b>X2X Link supply output</b>		
Rated output power		7.0 W
Parallel operation		Yes <sup>1)</sup>
Redundant operation of X2X Link supply		Yes
<small>1) In parallel operation, only 75% of the rated power can be assumed. Please ensure that all parallel operating power supplies are switched on and off simultaneously.</small>		
<b>Input I/O supply</b>		
Input voltage		24 VDC (-15% / +20%)
Fuse		Recommended pre-fusing max. 10 A slow-blow
<b>Output I/O supply</b>		
Rated output voltage		24 VDC
Permitted contact load		10.0 A
<b>General supply</b>		
Rated output power		7.0 W
<b>Status indicators</b>		
		Overload, operating status, module status, RS232 data transfer
<b>Diagnostics</b>		
Module run/error		Yes, with status LED and software status
Overload		Yes, with status LED and software status
RS232 data transfer		Yes, with status LED
<b>Electrical isolation</b>		
X2X bus supply		Yes
I/O supply		No

# CPU CP3486

General information	X20CP3486
Status indicators	CPU function, overtemperature, Ethernet, Ethernet POWERLINK, CompactFlash, battery
Diagnostics	
CPU function	Yes, with status LED
Over-temperature	Yes, with status LED
Ethernet	Yes, with status LED
Ethernet POWERLINK	Yes, with status LED
CompactFlash	Yes, with status LED
Battery	Yes, with status LED and software status
Fans	Yes, with software status
Visual Components capability	Yes
ACOPOS capability	Yes
Cooling	Fan-free with derating (see operational conditions) Exchangeable fans for entire temperature range Fan is monitored
Electrical isolation	
PLC - IF1/IF4/IF5	No
PLC - IF2/IF3/IF6	Yes
IF1/IF4/IF5 - IF2/IF3/IF6	Yes
IF1 - IF4/IF5	No
IF4 - IF5	No
Power consumption, without memory card, without interface module and USB	13.5 W
Internal power consumption of the X2X Link and I/O supply <sup>1)</sup>	
Bus	1.42 W
I/O internal	0.6 W
Certification	CE, C-UL-US, GOST-R
<sup>1)</sup> The specified values are maximum values. The exact calculation is available for download as a data sheet with the other module documentation on the B&R homepage.	
Operational conditions	X20CP3486
Operating temperature	
Horizontal installation	0°C to +55°C, fan-free: 0°C to +45°C
Vertical installation	0°C to +55°C, fan-free not permitted
Relative humidity	5 to 95%, non-condensing
Mounting orientation	Horizontal or vertical
Installation at altitudes above sea level	
0 - 2000 m	No derating
>2000 m	Reduction of ambient temperature by 0.5°C per 100 m
Protection type	IP20
Storage and transport conditions	X20CP3486
Temperature	-25°C to +70°C
Relative humidity	5 to 95%, non-condensing
Mechanical characteristics	X20CP3486
Dimensions (W x H x D)	200 x 99 x 85 mm
Comment	Order application memory (CompactFlash) separately Backup battery included in delivery X20 locking plate (right) included in delivery X20 terminal block (12-pin) included in delivery Interface module slot covers included in the delivery

Required accessories	
5CFCRD.0064-03	CompactFlash 64 MB ATA/IDE SiliconSystems
5CFCRD.0128-03	CompactFlash 128 MB ATA/IDE SiliconSystems
5CFCRD.0256-03	CompactFlash 256 MB ATA/IDE SiliconSystems
5CFCRD.0512-03	CompactFlash 512 MB ATA/IDE SiliconSystems
5CFCRD.1024-03	CompactFlash 1024 MB ATA/IDE SiliconSystems
5CFCRD.2048-03	CompactFlash 2048 MB ATA/IDE SiliconSystems
5CFCRD.4096-03	CompactFlash 4096 MB ATA/IDE SiliconSystems
5CFCRD.8192-03	CompactFlash 8192 MB ATA/IDE SiliconSystems
Optional accessories	
4A0006.00-000	Lithium battery, 3 V / 950 mAh, button cell
0AC201.9	Lithium batteries, 5 pcs., 3 V / 950 mAh, button cell
X20IFxxx	Communication with Ethernet POWERLINK, X2X Link, CAN bus, Profibus DP, RS232, RS422, RS485
X20AC0EF1	X20 CPU exchangeable fan

# CPU CP1486

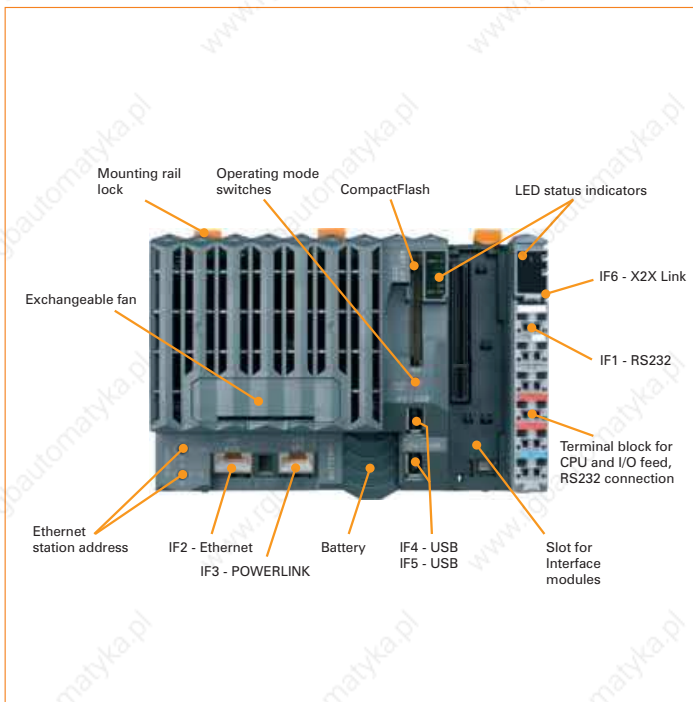

The CP1486 is a high-performance CPU for the X20 System. This CPU can be used anywhere from high-end applications in machine manufacturing to demanding tasks in process control.

Ethernet and USB are onboard. In addition, the CPU has a POWERLINK V1/V2 connection for real-time communication. The only differences from the CP3486 are that the CP1486 only has one slot for interface modules and a smaller width.

- Intel Celeron 650 Performance with additional I/O processor
- Ethernet, POWERLINK V1/V2 and USB onboard
- 1 slot for modular interface expansion
- Compact Flash as removable application memory
- Fan can be exchanged from the outside, tool-free
- Extremely compact

ETHERNET   
**POWERLINK**



<b>Short description</b>	<b>X20CP1486</b>
System module	CPU
Processor	Celeron 650
Interfaces	1x RS232, 1x Ethernet, 1x POWERLINK V1/V2, 2x USB, 1x X2X Link
<b>Controller</b>	<b>X20CP1486</b>
Fastest task class cycle time	200 $\mu$ s
Typical instruction cycle time	0.01 $\mu$ s
L1 cache for data and program code	2x 16 KB
L2 cache	256 KB
Standard memory	
Working memory (SDRAM)	64 MB SDRAM
User RAM (SRAM)	1 MB SRAM
Remanent variables	256 KB
FPU	Yes
Integrated I/O processor	Processes I/O data points in the background
Data buffering	
Lithium battery	At least 3 years
Battery monitoring	Yes
CompactFlash slot	1
Real-time clock	Nonvolatile memory, resolution 1 second
Modular interface slots	1

<b>Interfaces</b>		<b>X20CP1486</b>
<b>Interface IF1</b>		
Type		RS232
Design		Contact via 12-pin terminal block TB12
Maximum transfer rate		115.2 kBit/s
<b>Interface IF2</b>		
Type		Ethernet
Design		Shielded RJ45 port
Transfer rate		10/100 MBit/s
Cable length		Max. 100 m between two stations (segment length)
<b>Interface IF3</b>		
Fieldbus		POWERLINK V1/V2
Type		100 Base-T (ANSI/IEEE 802.3)
Design		Shielded RJ45 port
Transfer rate		100 MBit/s
Cable length		Max. 100 m between two stations (segment length)
<b>Interfaces IF4 and IF5</b>		
IF6 interface		USB Rev. 1.1
<b>CPU and X2X Link supply</b>		
Input voltage		24 VDC (-15% / +20%)
Input current		Max. 2.2 A
Reverse polarity protection		Yes
Fuse		Integrated, cannot be exchanged
<b>X2X Link supply output</b>		
Rated output power		7.0 W
Parallel operation		Yes <sup>1)</sup>
Redundant operation of X2X Link supply		Yes
1) In parallel operation, only 75% of the rated power can be assumed. Please ensure that all parallel operating power supplies are switched on and off simultaneously.		
<b>Input I/O supply</b>		
Input voltage		24 VDC (-15% / +20%)
Fuse		Recommended pre-fusing max. 10 A slow-blow
<b>Output I/O supply</b>		
Rated output voltage		24 VDC
Permitted contact load		10.0 A
<b>General supply</b>		
Status indicators		Overload, operating status, module status, RS232 data transfer
<b>Diagnostics</b>		
Module run/error		Yes, with status LED and software status
Overload		Yes, with status LED and software status
RS232 data transfer		Yes, with status LED
<b>Electrical isolation</b>		
X2X bus supply		Yes
I/O supply		No

# CPU CP1486

General information	X20CP1486
Status indicators	CPU function, overtemperature, Ethernet, Ethernet POWERLINK, CompactFlash, battery
Diagnostics	
CPU function	Yes, with status LED
Over-temperature	Yes, with status LED
Ethernet	Yes, with status LED
Ethernet POWERLINK	Yes, with status LED
CompactFlash	Yes, with status LED
Battery	Yes, with status LED and software status
Fans	Yes, with software status
Visual Components capability	Yes
ACOPOS capability	Yes
Cooling	Fan-free with derating (see operational conditions) Exchangeable fans for entire temperature range Fan is monitored
Electrical isolation	
PLC - IF1/IF4/IF5	No
PLC - IF2/IF3/IF6	Yes
IF1/IF4/IF5 - IF2/IF3/IF6	Yes
IF1 - IF4/IF5	No
IF4 - IF5	No
Power consumption, without memory card, without interface module and USB	13.5 W
Internal power consumption of the X2X Link and I/O supply <sup>1)</sup>	
Bus	1.42 W
I/O internal	0.6 W
Certification	CE, C-UL-US, GOST-R
<sup>1)</sup> The specified values are maximum values. The exact calculation is available for download as a data sheet with the other module documentation on the B&R homepage.	
Operational conditions	X20CP1486
Operating temperature	
Horizontal installation	0°C to +55°C, fan-free: 0°C to +45°C
Vertical installation	0°C to +55°C, fan-free not permitted
Relative humidity	5 to 95%, non-condensing
Mounting orientation	Horizontal or vertical
Installation at altitudes above sea level	
0 - 2000 m	No derating
>2000 m	Reduction of ambient temperature by 0.5°C per 100 m
Protection type	IP20
Storage and transport conditions	X20CP1486
Temperature	-25°C to +70°C
Relative humidity	5 to 95%, non-condensing
Mechanical characteristics	X20CP1486
Dimensions (W x H x D)	150 x 99 x 85 mm
Comment	Order application memory (CompactFlash) separately Backup battery included in delivery X20 locking plate (right) included in delivery X20 terminal block (12-pin) included in delivery Interface module slot covers included in the delivery

Required accessories	
5CFCRD.0064-03	CompactFlash 64 MB ATA/IDE SiliconSystems
5CFCRD.0128-03	CompactFlash 128 MB ATA/IDE SiliconSystems
5CFCRD.0256-03	CompactFlash 256 MB ATA/IDE SiliconSystems
5CFCRD.0512-03	CompactFlash 512 MB ATA/IDE SiliconSystems
5CFCRD.1024-03	CompactFlash 1024 MB ATA/IDE SiliconSystems
5CFCRD.2048-03	CompactFlash 2048 MB ATA/IDE SiliconSystems
5CFCRD.4096-03	CompactFlash 4096 MB ATA/IDE SiliconSystems
5CFCRD.8192-03	CompactFlash 8192 MB ATA/IDE SiliconSystems
Optional accessories	
4A0006.00-000	Lithium battery, 3 V / 950 mAh, button cell
0AC201.9	Lithium batteries, 5 pcs., 3 V / 950 mAh, button cell
X20IFxxx	Communication with Ethernet POWERLINK, X2X Link, CAN bus, Profibus DP, RS232, RS422, RS485
X20AC0EF1	X20 CPU exchangeable fan

# CPU CP3485

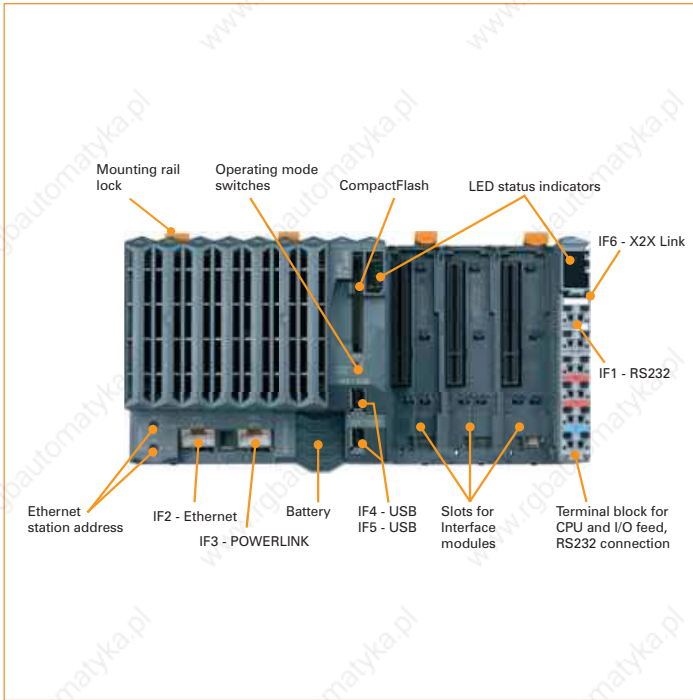

The CP3485 is a powerful CPU for the X20 System. This CPU is especially useful for applications which require short cycle times, have to process very large amounts of data, or carry out floating point operations.

Ethernet and USB are onboard. In addition, the CPU has a POWERLINK V1/V2 connection for real-time communication. In addition, there are three multi-purpose slots for additional interface modules.

- Intel Celeron 400 Performance with additional I/O processor
- Ethernet, POWERLINK V1/V2 and USB onboard
- 3 slots for modular interface expansion
- Compact Flash as removable application memory
- Fan-free
- Extremely compact

ETHERNET   
**POWERLINK**



<b>Short description</b>	<b>X20CP3485-1</b>
System module	CPU
Processor	Celeron 400
Interfaces	1x RS232, 1x Ethernet, 1x POWERLINK V1/V2, 2x USB, 1x X2X Link
<b>Controller</b>	<b>X20CP3485-1</b>
Fastest task class cycle time	400 $\mu$ s
Typical instruction cycle time	0.015 $\mu$ s
L1 cache for data and program code	2x 16 KB
L2 cache	256 KB
Standard memory	
Working memory (SDRAM)	64 MB SDRAM
User RAM (SRAM)	1 MB SRAM
Remanent variables	256 KB
FPU	Yes
Integrated I/O processor	Processes I/O data points in the background
Data buffering	
Lithium battery	At least 3 years
Battery monitoring	Yes
CompactFlash slot	1
Real-time clock	Nonvolatile memory, resolution 1 second
Modular interface slots	3

<b>Interfaces</b>	<b>X20CP3485-1</b>
<b>Interface IF1</b>	
Type	RS232
Design	Contact via 12-pin terminal block TB12
Maximum transfer rate	115.2 kBit/s
<b>Interface IF2</b>	
Type	Ethernet
Design	Shielded RJ45 port
Transfer rate	10/100 MBit/s
Cable length	Max. 100 m between two stations (segment length)
<b>Interface IF3</b>	
Fieldbus	POWERLINK V1/V2
Type	100 Base-T (ANSI/IEEE 802.3)
Design	Shielded RJ45 port
Transfer rate	100 MBit/s
Cable length	Max. 100 m between two stations (segment length)
<b>Interfaces IF4 and IF5</b>	
IF6 interface	USB Rev. 1.1
IF6 interface	X2X Link
<b>CPU and X2X Link supply</b>	
Input voltage	24 VDC (-15% / +20%)
Input current	Max. 2.2 A
Reverse polarity protection	Yes
Fuse	Integrated, cannot be exchanged
<b>X2X Link supply output</b>	
Rated output power	7.0 W
Parallel operation	Yes <sup>1)</sup>
Redundant operation of X2X Link supply	Yes
1) In parallel operation, only 75% of the rated power can be assumed. Please ensure that all parallel operating power supplies are switched on and off simultaneously.	
<b>Input I/O supply</b>	
Input voltage	24 VDC (-15% / +20%)
Fuse	Recommended pre-fusing max. 10 A slow-blow
<b>Output I/O supply</b>	
Rated output voltage	24 VDC
Permitted contact load	10.0 A
<b>General supply</b>	
General supply	X20CP3485-1
Status indicators	Overload, operating status, module status, RS232 data transfer
<b>Diagnostics</b>	
Module run/error	Yes, with status LED and software status
Overload	Yes, with status LED and software status
RS232 data transfer	Yes, with status LED
<b>Electrical isolation</b>	
X2X bus supply	Yes
I/O supply	No

# CPU CP3485

General information		X20CP3485-1
Status indicators	CPU function, overtemperature, Ethernet, Ethernet POWERLINK, CompactFlash, battery	
Diagnostics		
CPU function	Yes, with status LED	
Over-temperature	Yes, with status LED	
Ethernet	Yes, with status LED	
Ethernet POWERLINK	Yes, with status LED	
CompactFlash	Yes, with status LED	
Battery	Yes, with status LED and software status	
Visual Components capability	Yes	
ACOPOS capability	Yes	
Cooling	Fan-free	
Electrical isolation		
PLC - IF1/IF4/IF5	No	
PLC - IF2/IF3/IF6	Yes	
IF1/IF4/IF5 - IF2/IF3/IF6	Yes	
IF1 - IF4/IF5	No	
IF4 - IF5	No	
Power consumption, without memory card, without interface module and USB	10.5 W	
Internal power consumption of X2X Link and I/O supply <sup>1)</sup>		
Bus	1.42 W	
I/O internal	0.6 W	
Certification	CE, C-UL-US, GOST-R	
1) The specified values are maximum values. The exact calculation is available for download as a data sheet with the other module documentation on the B&R homepage.		
Operational conditions		X20CP3485-1
Operating temperature		
Horizontal installation	0°C to +55°C	
Vertical installation	0°C to +50°C	
Relative humidity	5 to 95%, non-condensing	
Mounting orientation		
Horizontal or vertical		
Installation at altitudes above sea level		
0 - 2000 m	No derating	
>2000 m	Reduction of ambient temperature by 0.5°C per 100 m	
Protection type	IP20	
Storage and transport conditions		X20CP3485-1
Temperature	-25°C to +70°C	
Relative humidity	5 to 95%, non-condensing	
Mechanical characteristics		X20CP3485-1
Dimensions (W x H x D)	200 x 99 x 85 mm	
Comment	Order application memory (CompactFlash) separately Backup battery included in delivery X20 locking plate (right) included in delivery X20 terminal block (12-pin) included in delivery Interface module slot covers included in the delivery	

<b>Required accessories</b>	
5CFCRD.0064-03	CompactFlash 64 MB ATA/IDE SiliconSystems
5CFCRD.0128-03	CompactFlash 128 MB ATA/IDE SiliconSystems
5CFCRD.0256-03	CompactFlash 256 MB ATA/IDE SiliconSystems
5CFCRD.0512-03	CompactFlash 512 MB ATA/IDE SiliconSystems
5CFCRD.1024-03	CompactFlash 1024 MB ATA/IDE SiliconSystems
5CFCRD.2048-03	CompactFlash 2048 MB ATA/IDE SiliconSystems
5CFCRD.4096-03	CompactFlash 4096 MB ATA/IDE SiliconSystems
5CFCRD.8192-03	CompactFlash 8192 MB ATA/IDE SiliconSystems
<b>Optional accessories</b>	
4A0006.00-000	Lithium battery, 3 V / 950 mAh, button cell
0AC201.9	Lithium batteries, 5 pcs., 3 V / 950 mAh, button cell
X20IFxxxx	Communication with Ethernet POWERLINK, X2X Link, CAN bus, Profibus DP, RS232, RS422, RS485

# CPU CP1485

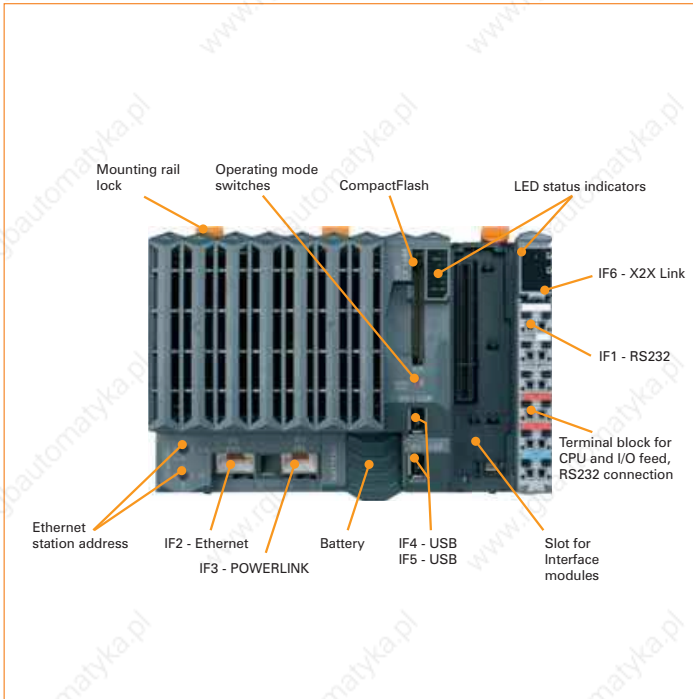

The CP1485 is a powerful CPU for the X20 System. This CPU is especially useful for applications which require short cycle times, have to process very large amounts of data, or carry out floating point operations.

Ethernet and USB are onboard. In addition, the CPU has a POWERLINK V1/V2 connection for real-time communication. The only differences from the CP3485 are that the CP1485 only has one slot for interface modules and a smaller width.

- Intel Celeron 400 Performance with additional I/O processor
- Ethernet, POWERLINK V1/V2 and USB onboard
- 1 slot for modular interface expansion
- Compact Flash as removable application memory
- Fan-free
- Extremely compact

ETHERNET   
**POWERLINK**



<b>Short description</b>	<b>X20CP1485-1</b>
System module	CPU
Processor	Celeron 400
Interfaces	1x RS232, 1x POWERLINK V1/V2, 2x USB, 1x X2X Link
<b>Controller</b>	<b>X20CP1485-1</b>
Fastest task class cycle time	400 $\mu$ s
Typical instruction cycle time	0.015 $\mu$ s
L1 cache for data and program code	2x 16 KB
L2 cache	256 KB
Standard memory	
Working memory (SDRAM)	64 MB SDRAM
User RAM (SRAM)	1 MB SRAM
Remanent variables	256 KB
FPU	Yes
Integrated I/O processor	Processes I/O data points in the background
Data buffering	
Lithium battery	At least 3 years
Battery monitoring	Yes
CompactFlash slot	1
Real-time clock	Nonvolatile memory, resolution 1 second
Modular interface slots	1

<b>Interfaces</b>	<b>X20CP1485-1</b>
Interface IF1	
Type	RS232
Design	Contact via 12-pin terminal block TB12
Maximum transfer rate	115.2 kBit/s
Interface IF2	
Type	Ethernet
Design	Shielded RJ45 port
Transfer rate	10/100 MBit/s
Cable length	Max. 100 m between two stations (segment length)
Interface IF3	
Fieldbus	POWERLINK V1/V2
Type	100 Base-T (ANSI/IEEE 802.3)
Design	Shielded RJ45 port
Transfer rate	100 MBit/s
Cable length	Max. 100 m between two stations (segment length)
Interfaces IF4 and IF5	USB Rev. 1.1
IF6 interface	X2X Link
<b>CPU and X2X Link supply</b>	<b>X20CP1485-1</b>
Input voltage	24 VDC (-15% / +20%)
Input current	Max. 2.2 A
Reverse polarity protection	Yes
Fuse	Integrated, cannot be exchanged
<b>X2X Link supply output</b>	<b>X20CP1485-1</b>
Rated output power	7.0 W
Parallel operation	Yes <sup>1)</sup>
Redundant operation of X2X Link supply	Yes
1) In parallel operation, only 75% of the rated power can be assumed. Please ensure that all parallel operating power supplies are switched on and off simultaneously.	
<b>Input I/O supply</b>	<b>X20CP1485-1</b>
Input voltage	24 VDC (-15% / +20%)
Fuse	Recommended pre-fusing max. 10 A slow-blow
<b>Output I/O supply</b>	<b>X20CP1485-1</b>
Rated output voltage	24 VDC
Permitted contact load	10.0 A
<b>General supply</b>	<b>X20CP1485-1</b>
Status indicators	Overload, operating status, module status, RS232 data transfer
Diagnostics	
Module run/error	Yes, with status LED and software status
Overload	Yes, with status LED and software status
RS232 data transfer	Yes, with status LED
Electrical isolation	
X2X bus supply	Yes
I/O supply	No

# CPU CP1485

General information		X20CP1485-1
Status indicators	CPU function, overtemperature, Ethernet, Ethernet POWERLINK, CompactFlash, battery	
<b>Diagnostics</b>		
CPU function	Yes, with status LED	
Over-temperature	Yes, with status LED	
Ethernet	Yes, with status LED	
Ethernet POWERLINK	Yes, with status LED	
CompactFlash	Yes, with status LED	
Battery	Yes, with status LED and software status	
Visual Components capability	Yes	
ACOPOS capability	Yes	
Cooling	Fan-free	
<b>Electrical isolation</b>		
PLC - IF1/IF4/IF5	No	
PLC - IF2/IF3/IF6	Yes	
IF1/IF4/IF5 - IF2/IF3/IF6	Yes	
IF1 - IF4/IF5	No	
IF4 - IF5	No	
Power consumption, without memory card, without interface module and USB	10.5 W	
<b>Internal power consumption of X2X Link and I/O supply <sup>1)</sup></b>		
Bus	1.42 W	
I/O internal	0.6 W	
Certification	CE, C-UL-US, GOST-R	
1) The specified values are maximum values. The exact calculation is available for download as a data sheet with the other module documentation on the B&R homepage.		
Operational conditions		X20CP1485-1
<b>Operating temperature</b>		
Horizontal installation	0°C to +55°C	
Vertical installation	0°C to +50°C	
Relative humidity	5 to 95%, non-condensing	
Mounting orientation	Horizontal or vertical	
<b>Installation at altitudes above sea level</b>		
0 - 2000 m	No derating	
>2000 m	Reduction of ambient temperature by 0.5°C per 100 m	
Protection type	IP20	
Storage and transport conditions		X20CP1485-1
Temperature	-25°C to +70°C	
Relative humidity	5 to 95%, non-condensing	
Mechanical characteristics		X20CP1485-1
Dimensions (W x H x D)	150 x 99 x 85 mm	
Comment	Order application memory (CompactFlash) separately Backup battery included in delivery X20 locking plate (right) included in delivery X20 terminal block (12-pin) included in delivery Interface module slot covers included in the delivery	

Required accessories	
5CFCRD.0064-03	CompactFlash 64 MB ATA/IDE SiliconSystems
5CFCRD.0128-03	CompactFlash 128 MB ATA/IDE SiliconSystems
5CFCRD.0256-03	CompactFlash 256 MB ATA/IDE SiliconSystems
5CFCRD.0512-03	CompactFlash 512 MB ATA/IDE SiliconSystems
5CFCRD.1024-03	CompactFlash 1024 MB ATA/IDE SiliconSystems
5CFCRD.2048-03	CompactFlash 2048 MB ATA/IDE SiliconSystems
5CFCRD.4096-03	CompactFlash 4096 MB ATA/IDE SiliconSystems
5CFCRD.8192-03	CompactFlash 8192 MB ATA/IDE SiliconSystems
Optional accessories	
4A0006.00-000	Lithium battery, 3 V / 950 mAh, button cell
0AC201.9	Lithium batteries, 5 pcs., 3 V / 950 mAh, button cell
X20IFxxxx	Communication with Ethernet POWERLINK, X2X Link, CAN bus, Profibus DP, RS232, RS422, RS485

# CPU CP3484

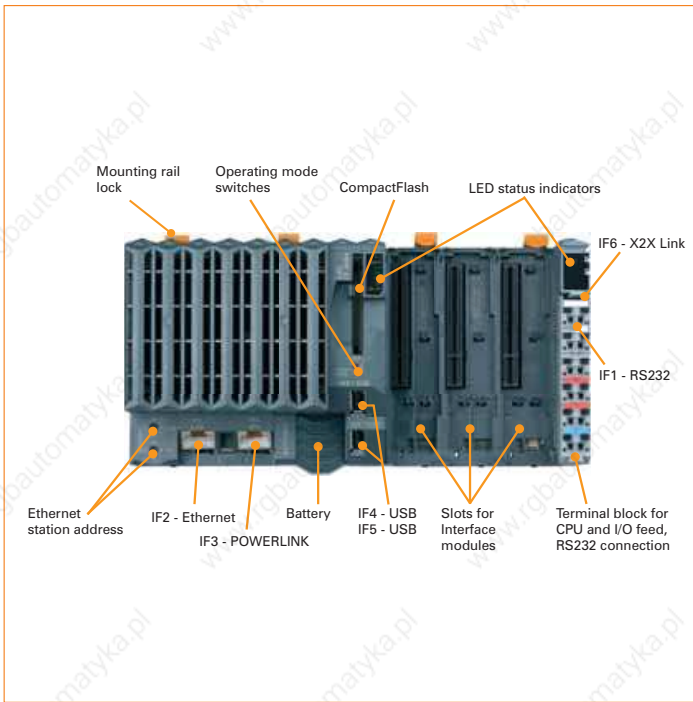

The CP3484 is the smallest Celeron based CPU for the X20 System. However, its shortest cycle time of 800  $\mu$ s still shows its power. The basic features are the same as those of the larger types.

Ethernet and USB are onboard. In addition, the CPU has a POWERLINK V1/V2 connection for real-time communication. In addition, there are three multi-purpose slots for additional interface modules.

- Intel Celeron 266 Performance with additional I/O processor
- Ethernet, POWERLINK V1/V2 and USB onboard
- 3 slots for modular interface expansion
- Compact Flash as removable application memory
- Fan-free
- Extremely compact

## ETHERNET POWERLINK



<b>Short description</b>	<b>X20CP3484</b>
System module	CPU
Processor	Celeron 266 comp.
Interfaces	1x RS232, 1x Ethernet, 1x POWERLINK V1/V2, 2x USB, 1x X2X Link
<b>Controller</b>	<b>X20CP3484</b>
Fastest task class cycle time	800 $\mu$ s
Typical instruction cycle time	0.022 $\mu$ s
L1 cache for data and program code	2x 16 KB
L2 cache	-
Standard memory	
Working memory (SDRAM)	32 MB SDRAM
User RAM (SRAM)	1 MB SRAM
Remanent variables	64 KB
FPU	Yes
Integrated I/O processor	Processes I/O data points in the background
Data buffering	
Lithium battery	At least 3 years
Battery monitoring	Yes
CompactFlash slot	1
Real-time clock	Nonvolatile memory, resolution 1 second
Modular interface slots	3

<b>Interfaces</b>		<b>X20CP3484</b>
<b>Interface IF1</b>		
Type		RS232
Design		Contact via 12-pin terminal block TB12
Maximum transfer rate		115.2 kBit/s
<b>Interface IF2</b>		
Type		Ethernet
Design		Shielded RJ45 port
Transfer rate		10/100 MBit/s
Cable length		Max. 100 m between two stations (segment length)
<b>Interface IF3</b>		
Fieldbus		POWERLINK V1/V2
Type		100 Base-T (ANSI/IEEE 802.3)
Design		Shielded RJ45 port
Transfer rate		100 MBit/s
Cable length		Max. 100 m between two stations (segment length)
<b>Interfaces IF4 and IF5</b>		
		USB Rev. 1.1
<b>IF6 interface</b>		
		X2X Link
<b>CPU and X2X Link supply</b>		<b>X20CP3484</b>
Input voltage		24 VDC (-15% / +20%)
Input current		Max. 2.2 A
Reverse polarity protection		Yes
Fuse		Integrated, cannot be exchanged
<b>X2X Link supply output</b>		<b>X20CP3484</b>
Rated output power		7.0 W
Parallel operation		Yes <sup>1)</sup>
Redundant operation of X2X Link supply		Yes
1) In parallel operation, only 75% of the rated power can be assumed. Please ensure that all parallel operating power supplies are switched on and off simultaneously.		
<b>Input I/O supply</b>		<b>X20CP3484</b>
Input voltage		24 VDC (-15% / +20%)
Fuse		Recommended pre-fusing max. 10 A slow-blow
<b>Output I/O supply</b>		<b>X20CP3484</b>
Rated output voltage		24 VDC
Permitted contact load		10.0 A
<b>General supply</b>		<b>X20CP3484</b>
Status indicators		Overload, operating status, module status, RS232 data transfer
<b>Diagnostics</b>		
Module run/error		Yes, with status LED and software status
Overload		Yes, with status LED and software status
RS232 data transfer		Yes, with status LED
<b>Electrical isolation</b>		
X2X bus supply		Yes
I/O supply		No

# CPU CP3484

General information		X20CP3484
Status indicators	CPU function, overtemperature, Ethernet, Ethernet POWERLINK, CompactFlash, battery	
Diagnostics		
CPU function	Yes, with status LED	
Over-temperature	Yes, with status LED	
Ethernet	Yes, with status LED	
Ethernet POWERLINK	Yes, with status LED	
CompactFlash	Yes, with status LED	
Battery	Yes, with status LED and software status	
Visual Components capability	Yes	
ACOPOS capability	Yes	
Cooling	Fan-free	
Electrical isolation		
PLC - IF1/IF4/IF5	No	
PLC - IF2/IF3/IF6	Yes	
IF1/IF4/IF5 - IF2/IF3/IF6	Yes	
IF1 - IF4/IF5	No	
IF4 - IF5	No	
Power consumption, without memory card, without interface module and USB	10.5 W	
Internal power consumption of X2X Link and I/O supply <sup>1)</sup>		
Bus	1.42 W	
I/O internal	0.6 W	
Certification	CE, C-UL-US, GOST-R	
1) The specified values are maximum values. The exact calculation is available for download as a data sheet with the other module documentation on the B&R homepage.		
Operational conditions		X20CP3484
Operating temperature		
Horizontal installation	0°C to +55°C	
Vertical installation	0°C to +50°C	
Relative humidity	5 to 95%, non-condensing	
Mounting orientation	Horizontal or vertical	
Installation at altitudes above sea level		
0 - 2000 m	No derating	
>2000 m	Reduction of ambient temperature by 0.5°C per 100 m	
Protection type	IP20	
Storage and transport conditions		X20CP3484
Temperature	-25°C to +70°C	
Relative humidity	5 to 95%, non-condensing	
Mechanical characteristics		X20CP3484
Dimensions (W x H x D)	200 x 99 x 85 mm	
Comment	Order application memory (CompactFlash) separately Backup battery included in delivery X20 locking plate (right) included in delivery X20 terminal block (12-pin) included in delivery Interface module slot covers included in the delivery	

<b>Required accessories</b>	
5CFCRD.0064-03	CompactFlash 64 MB ATA/IDE SiliconSystems
5CFCRD.0128-03	CompactFlash 128 MB ATA/IDE SiliconSystems
5CFCRD.0256-03	CompactFlash 256 MB ATA/IDE SiliconSystems
5CFCRD.0512-03	CompactFlash 512 MB ATA/IDE SiliconSystems
5CFCRD.1024-03	CompactFlash 1024 MB ATA/IDE SiliconSystems
5CFCRD.2048-03	CompactFlash 2048 MB ATA/IDE SiliconSystems
5CFCRD.4096-03	CompactFlash 4096 MB ATA/IDE SiliconSystems
5CFCRD.8192-03	CompactFlash 8192 MB ATA/IDE SiliconSystems
<b>Optional accessories</b>	
4A0006.00-000	Lithium battery, 3 V / 950 mAh, button cell
0AC201.9	Lithium batteries, 5 pcs., 3 V / 950 mAh, button cell
X20IFxxxx	Communication with Ethernet POWERLINK, X2X Link, CAN bus, Profibus DP, RS232, RS422, RS485

# CPU CP1484

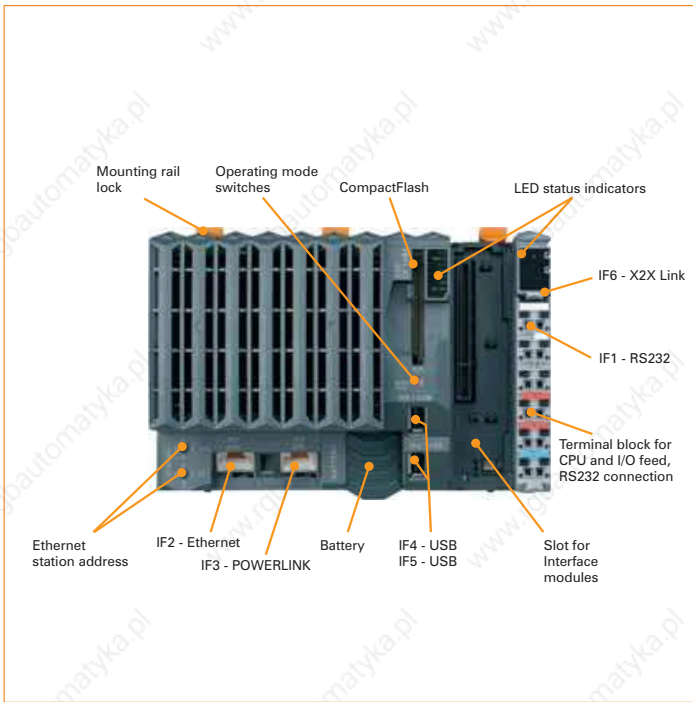

The CP1484 is the smallest Celeron based CPU for the X20 System. However, its shortest cycle time of 800  $\mu$ s still shows its power. The basic features are the same as those of the larger types.

Ethernet and USB are onboard. In addition, the CPU has a POWERLINK V1/V2 connection for real-time communication. The only differences from the CP3484 are that the CP1484 only has one slot for interface modules and a smaller width.

- Intel Celeron 266 Performance with additional I/O processor
- Ethernet, POWERLINK V1/V2 and USB onboard
- 1 slot for modular interface expansion
- Compact Flash as removable application memory
- Fan-free
- Extremely compact

ETHERNET   
**POWERLINK**



<b>Short description</b>	<b>X20CP1484</b>
System module	CPU
Processor	Celeron 266 comp.
Interfaces	1x RS232, 1x Ethernet, 1x POWERLINK V1/V2, 2x USB, 1x X2X Link
<b>Controller</b>	<b>X20CP1484</b>
Fastest task class cycle time	800 $\mu$ s
Typical instruction cycle time	0.022 $\mu$ s
L1 cache for data and program code	2x 16 KB
L2 cache	-
Standard memory	
Working memory (SDRAM)	32 MB SDRAM
User RAM (SRAM)	1 MB SRAM
Remanent variables	64 KB
FPU	Yes
Integrated I/O processor	Processes I/O data points in the background
Data buffering	
Lithium battery	At least 3 years
Battery monitoring	Yes
CompactFlash slot	1
Real-time clock	Nonvolatile memory, resolution 1 second
Modular interface slots	1

<b>Interfaces</b>		<b>X20CP1484</b>
<b>Interface IF1</b>		
Type		RS232
Design		Contact via 12-pin terminal block TB12
Maximum transfer rate		115.2 kBit/s
<b>Interface IF2</b>		
Type		Ethernet
Design		Shielded RJ45 port
Transfer rate		10/100 MBit/s
Cable length		Max. 100 m between two stations (segment length)
<b>Interface IF3</b>		
Fieldbus		POWERLINK V1/V2
Type		100 Base-T (ANSI/IEEE 802.3)
Design		Shielded RJ45 port
Transfer rate		100 MBit/s
Cable length		Max. 100 m between two stations (segment length)
<b>Interfaces IF4 and IF5</b>		
		USB Rev. 1.1
<b>IF6 interface</b>		
		X2X Link
<b>CPU and X2X Link supply</b>		<b>X20CP1484</b>
Input voltage		24 VDC (-15% / +20%)
Input current		Max. 2.2 A
Reverse polarity protection		Yes
Fuse		Integrated, cannot be exchanged
<b>X2X Link supply output</b>		<b>X20CP1484</b>
Rated output power		7.0 W
Parallel operation		Yes <sup>1)</sup>
Redundant operation of X2X Link supply		Yes
<small>1) In parallel operation, only 75% of the rated power can be assumed. Please ensure that all parallel operating power supplies are switched on and off simultaneously.</small>		
<b>Input I/O supply</b>		<b>X20CP1484</b>
Input voltage		24 VDC (-15% / +20%)
Fuse		Recommended pre-fusing max. 10 A slow-blow
<b>Output I/O supply</b>		<b>X20CP1484</b>
Rated output voltage		24 VDC
Permitted contact load		10.0 A
<b>General supply</b>		<b>X20CP1484</b>
Status indicators		Overload, operating status, module status, RS232 data transfer
<b>Diagnostics</b>		
Module run/error		Yes, with status LED and software status
Overload		Yes, with status LED and software status
RS232 data transfer		Yes, with status LED
<b>Electrical isolation</b>		
X2X bus supply		Yes
I/O supply		No

# CPU CP1484

General information		X20CP1484
Status indicators	CPU function, overtemperature, Ethernet, Ethernet POWERLINK, CompactFlash, battery	
<b>Diagnostics</b>		
CPU function	Yes, with status LED	
Over-temperature	Yes, with status LED	
Ethernet	Yes, with status LED	
Ethernet POWERLINK	Yes, with status LED	
CompactFlash	Yes, with status LED	
Battery	Yes, with status LED and software status	
Visual Components capability	Yes	
ACOPOS capability	Yes	
Cooling	Fan-free	
<b>Electrical isolation</b>		
PLC - IF1/IF4/IF5	No	
PLC - IF2/IF3/IF6	Yes	
IF1/IF4/IF5 - IF2/IF3/IF6	Yes	
IF1 - IF4/IF5	No	
IF4 - IF5	No	
Power consumption, without memory card, without interface module and USB	10.5 W	
<b>Internal power consumption of X2X Link and I/O supply <sup>1)</sup></b>		
Bus	1.42 W	
I/O internal	0.6 W	
Certification	CE, C-UL-US, GOST-R	
1) The specified values are maximum values. The exact calculation is available for download as a data sheet with the other module documentation on the B&R homepage.		
Operational conditions		X20CP1484
<b>Operating temperature</b>		
Horizontal installation	0°C to +55°C	
Vertical installation	0°C to +50°C	
Relative humidity	5 to 95%, non-condensing	
Mounting orientation	Horizontal or vertical	
<b>Installation at altitudes above sea level</b>		
0 - 2000 m	No derating	
>2000 m	Reduction of ambient temperature by 0.5°C per 100 m	
Protection type	IP20	
Storage and transport conditions		X20CP1484
Temperature	-25°C to +70°C	
Relative humidity	5 to 95%, non-condensing	
Mechanical characteristics		X20CP1484
Dimensions (W x H x D)	150 x 99 x 85 mm	
Comment	Order application memory (CompactFlash) separately Backup battery included in delivery X20 locking plate (right) included in delivery X20 terminal block (12-pin) included in delivery Interface module slot covers included in the delivery	

Required accessories	
5CFCRD.0064-03	CompactFlash 64 MB ATA/IDE SiliconSystems
5CFCRD.0128-03	CompactFlash 128 MB ATA/IDE SiliconSystems
5CFCRD.0256-03	CompactFlash 256 MB ATA/IDE SiliconSystems
5CFCRD.0512-03	CompactFlash 512 MB ATA/IDE SiliconSystems
5CFCRD.1024-03	CompactFlash 1024 MB ATA/IDE SiliconSystems
5CFCRD.2048-03	CompactFlash 2048 MB ATA/IDE SiliconSystems
5CFCRD.4096-03	CompactFlash 4096 MB ATA/IDE SiliconSystems
5CFCRD.8192-03	CompactFlash 8192 MB ATA/IDE SiliconSystems
Optional accessories	
4A0006.00-000	Lithium battery, 3 V / 950 mAh, button cell
0AC201.9	Lithium batteries, 5 pcs., 3 V / 950 mAh, button cell
X20IFxxxx	Communication with Ethernet POWERLINK, X2X Link, CAN bus, Profibus DP, RS232, RS422, RS485

# CPU CP1483

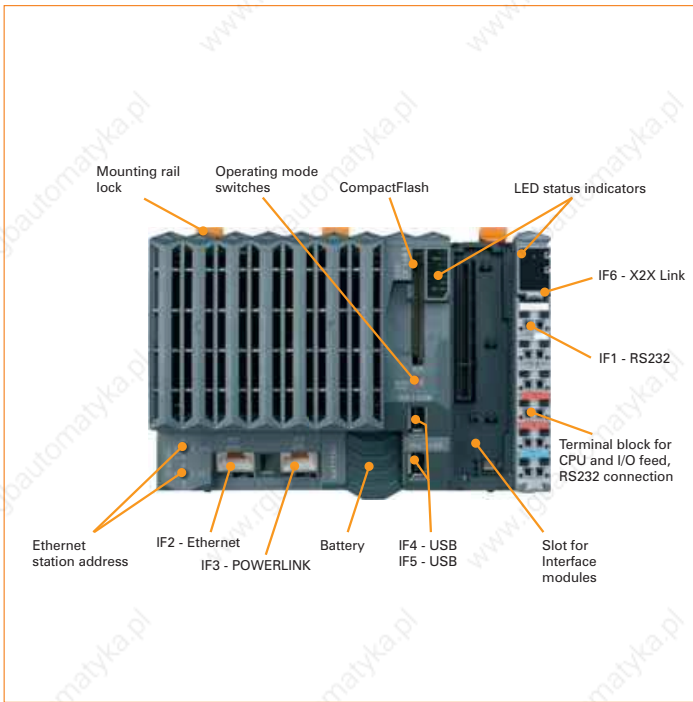

The x86 100 MHz-compatible CP1483 is the entry-level X20 CPU. With an optimum price/performance ratio, it has the same basic features as all of the larger CPUs.

Ethernet and USB are onboard. In addition, the CPU has a POWERLINK V1/V2 connection for real-time communication. In addition, a multi-purpose slot is provided for an additional interface module.

- Intel x86 100 MHz-compatible with additional I/O processor
- Ethernet, POWERLINK V1/V2 and USB onboard
- 1 slot for modular interface expansion
- Compact Flash as removable application memory
- Fan-free
- Extremely compact

## ETHERNET POWERLINK



<b>Short description</b>	<b>X20CP1483</b>
System module	CPU
Processor	x86 100 comp.
Interfaces	1x RS232, 1x Ethernet, 1x POWERLINK V1/V2, 2x USB, 1x X2X Link
<b>Controller</b>	<b>X20CP1483</b>
Fastest task class cycle time	1 ms
Typical instruction cycle time	0.076 $\mu$ s
L1 cache for data and program code	16 KB
L2 cache	-
Standard memory	
Working memory (SDRAM)	32 MByte
User RAM (SRAM)	128 KB
Remanent variables	32 KB
FPU	Yes
Integrated I/O processor	Processes I/O data points in the background
Data buffering	
Lithium battery	At least 3 years
Battery monitoring	Yes
CompactFlash slot	1
Real-time clock	Nonvolatile memory, resolution 1 second
Modular interface slots	1

<b>Interfaces</b>		<b>X20CP1483</b>
<b>Interface IF1</b>		
Type		RS232
Design		Contact via 12-pin terminal block TB12
Maximum transfer rate		115.2 kBit/s
<b>Interface IF2</b>		
Type		Ethernet
Design		Shielded RJ45 port
Transfer rate		10/100 MBit/s
Cable length		Max. 100 m between two stations (segment length)
<b>Interface IF3</b>		
Fieldbus		POWERLINK V1/V2
Type		100 Base-T (ANSI/IEEE 802.3)
Design		Shielded RJ45 port
Transfer rate		100 MBit/s
Cable length		Max. 100 m between two stations (segment length)
<b>Interfaces IF4 and IF5</b>		
		USB Rev. 1.1
IF6 interface		X2X Link
<b>CPU and X2X Link supply</b>		<b>X20CP1483</b>
Input voltage		24 VDC (-15% / +20%)
Input current		Max. 2.2 A
Reverse polarity protection		Yes
Fuse		Integrated, cannot be exchanged
<b>X2X Link supply output</b>		<b>X20CP1483</b>
Rated output power		7.0 W
Parallel operation		Yes <sup>1)</sup>
Redundant operation of X2X Link supply		Yes
1) In parallel operation, only 75% of the rated power can be assumed. Please ensure that all parallel operating power supplies are switched on and off simultaneously.		
<b>Input I/O supply</b>		<b>X20CP1483</b>
Input voltage		24 VDC (-15% / +20%)
Fuse		Recommended pre-fusing max. 10 A slow-blow
<b>Output I/O supply</b>		<b>X20CP1483</b>
Rated output voltage		24 VDC
Permitted contact load		10.0 A
<b>General supply</b>		<b>X20CP1483</b>
Status indicators		Overload, operating status, module status, RS232 data transfer
<b>Diagnostics</b>		
Module run/error		Yes, with status LED and software status
Overload		Yes, with status LED and software status
RS232 data transfer		Yes, with status LED
<b>Electrical isolation</b>		
X2X bus supply		Yes
I/O supply		No

# CPU CP1483

General information		X20CP1483
Status indicators	CPU function, overtemperature, Ethernet, Ethernet POWERLINK, CompactFlash, battery	
<b>Diagnostics</b>		
CPU function	Yes, with status LED	
Over-temperature	Yes, with status LED	
Ethernet	Yes, with status LED	
Ethernet POWERLINK	Yes, with status LED	
CompactFlash	Yes, with status LED	
Battery	Yes, with status LED and software status	
Fan diagnostics	-	
Visual Components capability	Yes	
ACOPOS capability	Yes	
Cooling	Fan-free	
<b>Electrical isolation</b>		
PLC - IF1/IF4/IF5	No	
PLC - IF2/IF3/IF6	Yes	
IF1/IF4/IF5 - IF2/IF3/IF6	Yes	
IF1 - IF4/IF5	No	
IF4 - IF5	No	
Power consumption, without memory card, without interface module and USB	TBD	
<b>Internal power consumption of X2X Link and I/O supply <sup>1)</sup></b>		
Bus	1.22 W	
I/O internal	0.6 W	
Certification	CE, C-UL-US (in development), GOST-R	
1) The specified values are maximum values. The exact calculation is available for download as a data sheet with the other module documentation on the B6R homepage.		
Operational conditions		X20CP1483
<b>Operating temperature</b>		
Horizontal installation	0°C to +55°C	
Vertical installation	0°C to +50°C	
Relative humidity	5 to 95%, non-condensing	
Mounting orientation	Horizontal or vertical	
<b>Installation at altitudes above sea level</b>		
0 - 2000 m	No derating	
>2000 m	Reduction of ambient temperature by 0.5°C per 100 m	
Protection type	IP20	
Storage and transport conditions		X20CP1483
Temperature	-25°C to +70°C	
Relative humidity	5 to 95%, non-condensing	
Mechanical characteristics		X20CP1483
Dimensions (W x H x D)	150 x 99 x 85 mm	
Comment	Order application memory (CompactFlash) separately Backup battery included in delivery X20 locking plate (right) included in delivery X20 terminal block (12-pin) included in delivery Interface module slot covers included in the delivery	

<b>Required accessories</b>	
5CFCRD.0064-03	CompactFlash 64 MB ATA/IDE SiliconSystems
5CFCRD.0128-03	CompactFlash 128 MB ATA/IDE SiliconSystems
5CFCRD.0256-03	CompactFlash 256 MB ATA/IDE SiliconSystems
5CFCRD.0512-03	CompactFlash 512 MB ATA/IDE SiliconSystems
5CFCRD.1024-03	CompactFlash 1024 MB ATA/IDE SiliconSystems
5CFCRD.2048-03	CompactFlash 2048 MB ATA/IDE SiliconSystems
5CFCRD.4096-03	CompactFlash 4096 MB ATA/IDE SiliconSystems
5CFCRD.8192-03	CompactFlash 8192 MB ATA/IDE SiliconSystems
<b>Optional accessories</b>	
4A0006.00-000	Lithium battery, 3 V / 950 mAh, button cell
0AC201.9	Lithium batteries, 5 pcs., 3 V / 950 mAh, button cell
X20IFxxxx	Communication with Ethernet POWERLINK, X2X Link, CAN bus, Profibus DP, RS232, RS422, RS485

# Compact CPUs

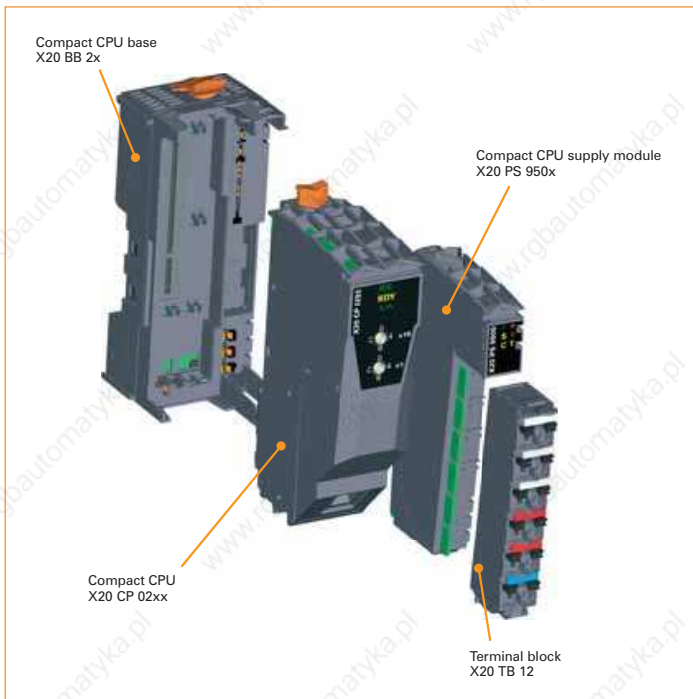

## Compact CPUs with a modular design

The completely modular structure of the Compact CPUs allows the user to assemble a CPU that meets the unique power supply and interface requirements.

### Compact CPU

- Embedded  $\mu$ P 25 with Ethernet on-board
- Embedded  $\mu$ P 16 with or without Ethernet on-board

### Bus module

- Bus module with RS232 connection
- Bus module with RS232 and CAN bus connections

### Supply module

- Supply module for Compact CPU, X2X Link bus supply and I/O
- RS232 interface
- CAN bus
- Without or without electrical isolation of the CPU/X2X Link supply

### Terminal block

- 12-pin terminal block

## The battery-free CPU

To meet the high demands of the market, the Compact CPU was designed to run without a battery. The following features make operation without a buffer battery possible.

### Real-time clock

The real-time clock is buffered for approx. 1000 hours by a gold foil capacitor.

### FRAM instead of SRAM for remanent variables

This FRAM stores its contents ferromagnetically. Unlike normal SRAM, this does not require a battery.

## Compact design

Despite the sleek profile of only 37.5 mm, the CPU feed, the X2X Link bus supply, and the I/O module feed are integrated in the CPU. No additional power modules are necessary.



# Compact CPU CP0292



The structure of the X20 Compact CPU is described on page 124. In addition to the structure, other general information is also provided.

The CP0292 is the most powerful of the X20 Compact CPUs. Equipped with Embedded  $\mu$ P 25 and additional memory, it is predestined for drive and visualization applications.

The CPU is network-capable due to an onboard Ethernet interface.

- Embedded  $\mu$ P 25
- 750 KB User SRAM
- 3 MB User FlashPROM
- Ethernet on-board
- Only 37.5 mm wide
- Battery-free



<b>Short description</b>	<b>X20CP0292</b>
System module	CPU
Processor	Embedded $\mu$ P 25
Interfaces	1x Ethernet onboard
<b>Controller</b>	<b>X20CP0292</b>
Fastest task class cycle time	2 ms
Typical instruction cycle time	0.5 $\mu$ s
Standard memory	
User RAM	750 KByte SRAM <sup>1)</sup>
User PROM	3 MB FlashPROM
Remanent variables	2.75 KByte FRAM <sup>2)</sup>
Backup battery	No
Integrated I/O processor	Processes I/O data points in the background
Real-time clock <sup>3)</sup>	Yes, resolution 1 s

1) Not buffered.

2) The FRAM stores its contents ferromagnetically. Therefore, no buffer battery is needed.

3) The real-time clock is buffered for approx. 1000 hours by a gold foil capacitor. The gold foil capacitor is completely loaded after 18 continuous hours of operation.

<b>Interfaces</b>	<b>X20CP0292</b>
Interface IF2	
Type	Ethernet
Design	Shielded RJ45 port
Transfer rate	100 MBit/s
Cable length	Max. 100 m between two stations (segment length)
Additional interfaces	
X20BB22	Compact CPU base module with integrated RS232 interface
X20BB27	Compact CPU base module with integrated RS232 and CAN interfaces
<b>General information</b>	<b>X20CP0292</b>
Status indicators	CPU function, Ethernet
Diagnostics	
CPU function	Yes, with status LED
Ethernet	Yes, with status LED
Over-temperature	Yes, with software status
Visual Components capability	Yes
ACOPOS capability	Yes
Temperature sensor	Yes
Electrical isolation	
PLC - IF2	Yes
Power consumption	3.0 W
Certification	CE, C-UL-US, GOST-R
<b>Operational conditions</b>	<b>X20CP0292</b>
Operating temperature	
Horizontal installation	0°C to +55°C
Vertical installation	0°C to +50°C
Relative humidity	5 to 95%, non-condensing
Mounting orientation	Horizontal or vertical
Installation at altitudes above sea level	
0 - 2000 m	No derating
>2000 m	Reduction of ambient temperature by 0.5°C per 100 m
Protection type	IP20
<b>Storage and transport conditions</b>	<b>X20CP0292</b>
Temperature	-25°C to +70°C
Relative humidity	5 to 95%, non-condensing
<b>Mechanical characteristics</b>	<b>X20CP0292</b>
Grid size <sup>1)</sup>	37.5 <sup>+0.2</sup> mm
Comment	Order terminal block 1x X20TB12 separately Order supply module 1x X20PS9500 or X20PS9502 separately Order Compact CPU base 1x X20BB22 or X20BB27 separately

1) Spacing is based on the width of the Compact CPU base X20BB22 or X20BB27. An X20PS9500 or X20PS9502 supply module is also always required for the CPU.

Required accessories		
X20TB12	X20 terminal block, 12-pin, 24 V coded	94
X20BB22	X20 Compact CPU base, for Compact CPU and Compact CPU supply module, base for integrated RS232 interface, X20 connection, X20 end plates (left and right), X20AC0SL1/X20AC0SR1 included	132
X20BB27	X20 Compact CPU base, for Compact CPU and Compact CPU supply module, base for integrated RS232 and CAN interfaces, X20 connection, X20 end plates (left and right), X20AC0SL1/X20AC0SR1 included	133
X20PS9500	X20 supply module for Compact and fieldbus CPUs and internal I/O supply, X2X Link bus supply	134
X20PS9502	X20 supply module for Compact and fieldbus CPUs and internal I/O supply, X2X Link bus supply, supply feed not electrically isolated	138

## Compact CPU CP0291



The structure of the X20 Compact CPU is described on page 124. In addition to the structure, other general information is also provided.

With the same processor and the same amount of memory, the CP0291 is just as powerful as the CP0201.

The CP0291, however, also has an onboard Ethernet interface.

- Embedded  $\mu$ P 16
- 100 KB User SRAM
- 1 MB User FlashPROM
- Ethernet on-board
- Only 37.5 mm wide
- Battery-free



Short description	X20CP0291
System module	CPU
Processor	Embedded $\mu$ P 16
Interfaces	1x Ethernet onboard
Controller	X20CP0291
Fastest task class cycle time	4 ms
Typical instruction cycle time	0.8 $\mu$ s
Standard memory	
User RAM	100 KByte SRAM <sup>1)</sup>
User PROM	1 MB FlashPROM
Remanent variables	2.75 KByte FRAM <sup>2)</sup>
Backup battery	No
Integrated I/O processor	Processes I/O data points in the background
Real-time clock <sup>3)</sup>	Yes, resolution 1 s

1) Not buffered.

2) The FRAM stores its contents ferromagnetically. Therefore, no buffer battery is needed.

3) The real-time clock is buffered for approx. 1000 hours by a gold foil capacitor. The gold foil capacitor is completely loaded after 18 continuous hours of operation.

<b>Interfaces</b>		<b>X20CP0291</b>
Interface IF2		
Type	Ethernet	
Design	Shielded RJ45 port	
Transfer rate	100 MBit/s	
Cable length	Max. 100 m between two stations (segment length)	
Additional interfaces		
X20BB22	Compact CPU base module with integrated RS232 interface	
X20BB27	Compact CPU base module with integrated RS232 and CAN interfaces	
<b>General information</b>		<b>X20CP0291</b>
Status indicators	CPU function, Ethernet	
Diagnostics		
CPU function	Yes, with status LED	
Ethernet	Yes, with status LED	
Visual Components capability	Limited (User PROM)	
ACOPOS capability	Limited (User PROM)	
Temperature sensor	No	
Electrical isolation		
PLC - IF2	Yes	
Power consumption	2.7 W	
Certification	CE, C-UL-US, GOST-R	
<b>Operational conditions</b>		<b>X20CP0291</b>
Operating temperature		
Horizontal installation	0°C to +55°C	
Vertical installation	0°C to +50°C	
Relative humidity	5 to 95%, non-condensing	
Mounting orientation		
Installation at altitudes above sea level	Horizontal or vertical	
0 - 2000 m	No derating	
>2000 m	Reduction of ambient temperature by 0.5°C per 100 m	
Protection type	IP20	
<b>Storage and transport conditions</b>		<b>X20CP0291</b>
Temperature	-25°C to +70°C	
Relative humidity	5 to 95%, non-condensing	
<b>Mechanical characteristics</b>		<b>X20CP0291</b>
Grid size <sup>1)</sup>	37.5 <sup>+0.2</sup> mm	
Comment		
Order terminal block 1x X20TB12 separately		
Order supply module 1x X20PS9500 or X20PS9502 separately		
Order Compact CPU base 1x X20BB22 or X20BB27 separately		

1) Spacing is based on the width of the Compact CPU base X20BB22 or X20BB27. An X20PS9500 or X20PS9502 supply module is also always required for the CPU.

<b>Required accessories</b>		
X20TB12	X20 terminal block, 12-pin, 24 V coded	▣ 94
X20BB22	X20 Compact CPU base, for Compact CPU and Compact CPU supply module, base for integrated RS232 interface, X20 connection, X20 end plates (left and right), X20AC0SL1/X20AC0SR1 included	▣ 132
X20BB27	X20 Compact CPU base, for Compact CPU and Compact CPU supply module, base for integrated RS232 and CAN interfaces, X20 connection, X20 end plates (left and right), X20AC0SL1/X20AC0SR1 included	▣ 133
X20PS9500	X20 supply module for Compact and fieldbus CPUs and internal I/O supply, X2X Link bus supply	▣ 134
X20PS9502	X20 supply module for Compact and fieldbus CPUs and internal I/O supply, X2X Link bus supply, supply feed not electrically isolated	▣ 138

## Compact CPU CP0201



The structure of the X20 Compact CPU is described on page 124. In addition to the structure, other general information is also provided.

The CP0201 is the entry-level X20 Compact CPU. This CPU is used when a cycle time of 2 ms (typ. 5 ms) is sufficient and the cost/performance ratio is a key factor.

Going without an onboard Ethernet interface additionally reduces costs for the CP0201.

- Embedded  $\mu$ P 16
- 100 KB User SRAM
- 1 MB User FlashPROM
- Only 37.5 mm wide
- Battery-free



Short description	X20CP0201
System module	CPU
Processor	Embedded $\mu$ P 16
Controller	X20CP0201
Fastest task class cycle time	4 ms
Typical instruction cycle time	0.8 $\mu$ s
Standard memory	
User RAM	100 KByte SRAM <sup>1)</sup>
User PROM	1 MB FlashPROM
Remanent variables	2.75 KByte FRAM <sup>2)</sup>
Backup battery	No
Integrated I/O processor	Processes I/O data points in the background
Real-time clock <sup>3)</sup>	Yes, resolution 1 s

1) Not buffered.

2) The FRAM stores its contents ferromagnetically. Therefore, no buffer battery is needed.

3) The real-time clock is buffered for approx. 1000 hours by a gold foil capacitor. The gold foil capacitor is completely loaded after 18 continuous hours of operation.

<b>Interfaces</b>	<b>X20CP0201</b>
Interfaces are located on the base module	
X20BB22	Compact CPU base module with integrated RS232 interface
X20BB27	Compact CPU base module with integrated RS232 and CAN interfaces
<b>General information</b>	<b>X20CP0201</b>
Status indicators	CPU function
<b>Diagnostics</b>	
CPU function	Yes, with status LED
Visual Components capability	Limited (User PROM)
ACOPOS capability	Limited (User PROM)
Temperature sensor	No
Power consumption	2.2 W
Certification	CE, C-UL-US, GOST-R
<b>Operational conditions</b>	<b>X20CP0201</b>
Operating temperature	
Horizontal installation	0°C to +55°C
Vertical installation	0°C to +50°C
Relative humidity	5 to 95%, non-condensing
Mounting orientation	Horizontal or vertical
Installation at altitudes above sea level	
0 - 2000 m	No derating
>2000 m	Reduction of ambient temperature by 0.5°C per 100 m
Protection type	IP20
<b>Storage and transport conditions</b>	<b>X20CP0201</b>
Temperature	-25°C to +70°C
Relative humidity	5 to 95%, non-condensing
<b>Mechanical characteristics</b>	<b>X20CP0201</b>
Grid size <sup>1)</sup>	37.5 <sup>+0.2</sup> mm
Comment	Order terminal block 1x X20TB12 separately Order supply module 1x X20PS9500 or X20PS9502 separately Order Compact CPU base 1x X20BB22 or X20BB27 separately

1) Spacing is based on the width of the Compact CPU base X20BB22 or X20BB27. An X20PS9500 or X20PS9502 supply module is also always required for the CPU.

Required accessories		
X20TB12	X20 terminal block, 12-pin, 24 V coded	94
X20BB22	X20 Compact CPU base, for Compact CPU and Compact CPU supply module, base for integrated RS232 interface, X20 connection, X20 end plates (left and right), X20AC0SL1/X20AC0SR1 included	132
X20BB27	X20 Compact CPU base, for Compact CPU and Compact CPU supply module, base for integrated RS232 and CAN interfaces, X20 connection, X20 end plates (left and right), X20AC0SL1/X20AC0SR1 included	133
X20PS9500	X20 supply module for Compact and fieldbus CPUs and internal I/O supply, X2X Link bus supply	134
X20PS9502	X20 supply module for Compact and fieldbus CPUs and internal I/O supply, X2X Link bus supply, supply feed not electrically isolated	138

# Bus module BB22



The BB22 bus module is the base for all X20 Compact CPUs. The left and right locking plates are included in the delivery.

- Base for all X20 Compact CPUs
- RS232 connection

<b>Short description</b>	<b>X20BB22</b>
Bus module	X20 Compact CPU base - backplane for Compact CPU and Compact CPU supply module
Interfaces	1x RS232 connection
<b>General information</b>	<b>X20BB22</b>
Electrical isolation	
Bus - RS232	No
Power consumption	
Bus	0.32 W
I/O internal	-
Certification	CE, C-UL-US, GOST-R
<b>Operational conditions</b>	<b>X20BB22</b>
Operating temperature	
Horizontal installation	0°C to +55°C
Vertical installation	0°C to +50°C
Relative humidity	5 to 95%, non-condensing
Mounting orientation	Horizontal or vertical
Installation at altitudes above sea level	
0 - 2000 m	No derating
>2000 m	Reduction of ambient temperature by 0.5°C per 100 m
Protection type	IP20
<b>Storage and transport conditions</b>	<b>X20BB22</b>
Temperature	-25°C to +70°C
Relative humidity	5 to 95%, non-condensing
<b>Mechanical characteristics</b>	<b>X20BB22</b>
Spacing	37.5 <sup>+0.2</sup> mm
Comment	Left and right X20 end plates included in delivery

## Potential control

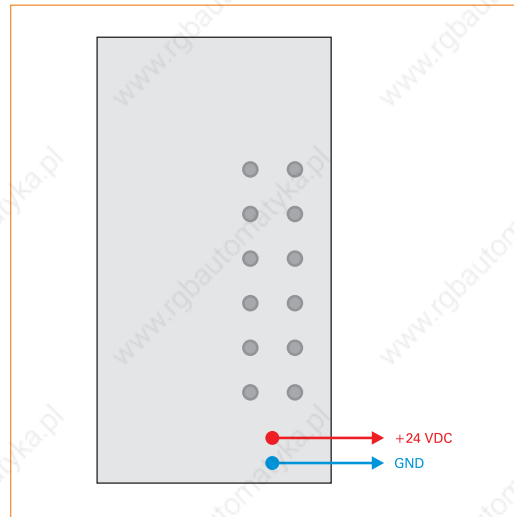

# Bus module BB27



The BB27 bus module is the base for all X20 Compact CPUs. The left and right locking plates are included in the delivery.

- Base for all X20 Compact CPUs
- RS232 connection
- CAN bus connection
- Integrated terminating resistor for CAN bus

<b>Short description</b>	<b>X20BB27</b>
Bus module	X20 Compact CPU base - backplane for Compact CPU and Compact CPU supply module
Interfaces	1x RS232 connection, 1x CAN bus connection
<b>General information</b>	<b>X20BB27</b>
<b>Electrical isolation</b>	
Bus - RS232	No
Bus - CAN bus	No
RS232 - CAN bus	No
<b>Power consumption</b>	
Bus	0.53 W
I/O internal	-
Certification	CE, C-UL-US, GOST-R
<b>Operational conditions</b>	<b>X20BB27</b>
<b>Operating temperature</b>	
Horizontal installation	0°C to +55°C
Vertical installation	0°C to +50°C
<b>Relative humidity</b>	
Relative humidity	5 to 95%, non-condensing
<b>Mounting orientation</b>	
Mounting orientation	Horizontal or vertical
<b>Installation at altitudes above sea level</b>	
0 - 2000 m	No derating
>2000 m	Reduction of ambient temperature by 0.5°C per 100 m
Protection type	IP20
<b>Storage and transport conditions</b>	<b>X20BB27</b>
Temperature	-25°C to +70°C
Relative humidity	5 to 95%, non-condensing
<b>Mechanical characteristics</b>	<b>X20BB27</b>
Spacing	37.5 <sup>+0.2</sup> mm
Comment	Left and right X20 end plates included in delivery

## Potential control

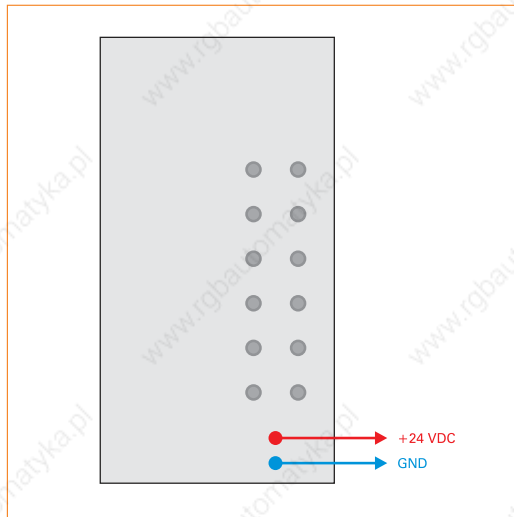

## Supply module PS9500



The supply module PS9500 is used together with an X20 Compact or Fieldbus CPU. It is equipped with a feed for the CPU, the X2X Link, and the internal I/O supply.

- Supply for the Compact or Fieldbus CPU, X2X Link, and internal I/O supply
- Electrical isolation of feed and CPU / X2X Link supply
- Redundancy of CPU / X2X Link supply possible by operating multiple supply modules simultaneously
- RS232 can be configured as an online interface
- CAN bus

<b>Short description</b>	<b>X20PS9500</b>
Power supply module	24 VDC supply module for Compact or Fieldbus CPUs, X2X Link bus supply and I/O
Interfaces	1x RS232, 1x CAN bus <sup>1)</sup>
<small>1) CAN bus only together with the X20BB27 X20BB37 or X20BB47 bus module.</small>	
<b>CPU / X2X Link supply input</b>	<b>X20PS9500</b>
Input voltage	24 VDC (-15% / +20%)
Input current	Max. 0.7 A
Reverse polarity protection	Yes
Fuse	Integrated, cannot be exchanged
<b>CPU / X2X Link supply output</b>	<b>X20PS9500</b>
Rated output power	7.0 W
Parallel operation	Yes <sup>1)</sup>
Redundant operation of the CPU / X2X Link supply	Yes
<small>1) In parallel operation, only 75% of the rated power can be assumed. Please ensure that all parallel operating power supplies are switched on and off simultaneously.</small>	
<b>Input I/O supply</b>	<b>X20PS9500</b>
Input voltage	24 VDC (-15% / +20%)
Fuse	Recommended pre-fusing max. 10 A slow-blow
<b>Output I/O supply</b>	<b>X20PS9500</b>
Rated output voltage	24 VDC
Permitted contact load	10.0 A
<b>Interfaces</b>	<b>X20PS9500</b>
<b>Interface IF1</b>	
Type	RS232
Design	Contact via 12-pin terminal block TB12
Maximum transfer rate	115.2 kBit/s
<b>Interface IF3 <sup>1)</sup></b>	
Type	CAN bus
Design	Contact via 12-pin terminal block TB12
Maximum transfer rate	1 MBit/s
<small>1) CAN bus only together with the X20BB27 X20BB37 or X20BB47 bus module.</small>	
<b>General information</b>	<b>X20PS9500</b>
Status indicators	Overload, operating status, module status, RS232, CAN bus <sup>1)</sup>
<b>Diagnostics</b>	
Module run/error	Yes, with status LED and software status
Overload	Yes, with status LED and software status
RS232 data transfer	Yes, with status LED
CAN bus data transfer <sup>1)</sup>	Yes, with status LED
<b>Electrical isolation</b>	
CPU / X2X bus supply	Yes
I/O supply	No
<b>Power consumption <sup>2)</sup></b>	
Bus	1.42 W
I/O internal	0.6 W
Certification	CE, C-UL-US, GOST-R
<small>1) CAN bus only together with the X20BB27 X20BB37 or X20BB47 bus module.</small>	
<small>2) The specified values are maximum values. The exact calculation is available for download as a data sheet with the other module documentation on the B&amp;R homepage.</small>	

<b>Operational conditions</b>	<b>X20PS9500</b>
Operating temperature	
Horizontal installation	0°C to +55°C
Vertical installation	0°C to +50°C
Relative humidity	5 to 95%, non-condensing
Mounting orientation	Horizontal or vertical
Installation at altitudes above sea level	
0 - 2000 m	No derating
>2000 m	Reduction of ambient temperature by 0.5°C per 100 m
Protection type	IP20
<b>Storage and transport conditions</b>	<b>X20PS9500</b>
Temperature	-25°C to +70°C
Relative humidity	5 to 95%, non-condensing
<b>Mechanical characteristics</b>	<b>X20PS9500</b>
Spacing	12.5 <sup>+0.2</sup> mm
Comment	Order terminal block 1x X20TB12 separately Order Compact CPU base 1x X20BB22 or X20BB27 separately Order Fieldbus CPU base 1x X20BB3x/4x separately

# Supply module PS9500

## Pin assignments

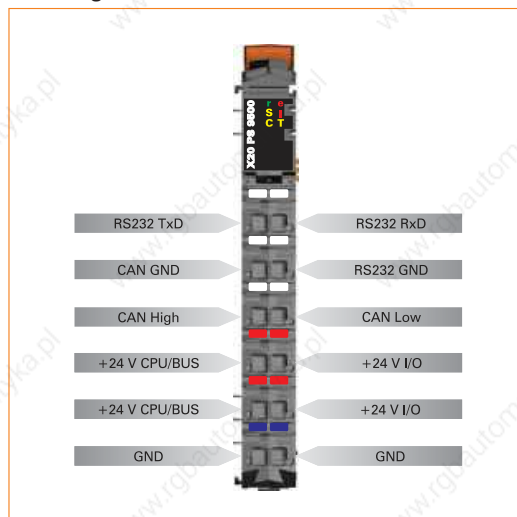

## Connection example

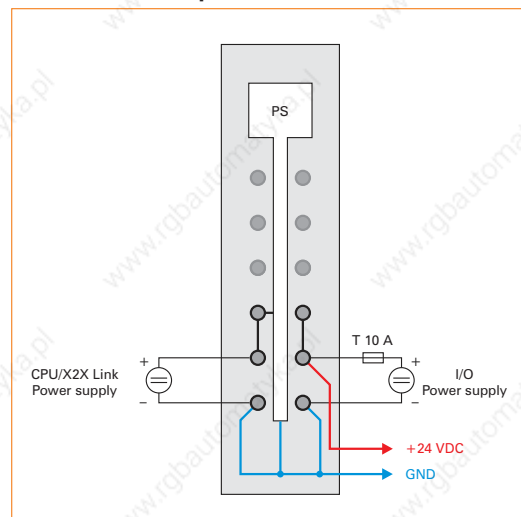

### Required accessories

X20TB12	X20 terminal block, 12-pin, 24 V coded	▮ 94
X20BB22	X20 Compact CPU base, for Compact CPU and Compact CPU supply module, base for integrated RS232 interface, X20 connection, X20 end plates (left and right), X20AC0SL1/X20AC0SR1 included	▮ 132
X20BB27	X20 Compact CPU base, for Compact CPU and Compact CPU supply module, base for integrated RS232 and CAN interfaces, X20 connection, X20 end plates (left and right), X20AC0SL1/X20AC0SR1 included	▮ 133
X20BB32	X20 Fieldbus CPU base, for Fieldbus CPU and Compact CPU supply module, base for integrated RS232 interface, slot for X20 interface module, X20 connection, X20 end plates (left and right), X20AC0SL1/X20AC0SR1 included	▮ 150
X20BB37	X20 Fieldbus CPU base, for Fieldbus CPU and Compact CPU supply module, base for integrated RS232 and CAN interface, slot for X20 interface module, X20 connection, X20 end plates (left and right), X20AC0SL1/X20AC0SR1 included	▮ 151
X20BB42	X20 Fieldbus CPU base, for Fieldbus CPU and Compact CPU supply module, base for integrated RS232 interface, 2x slots for X20 interface modules, X20 connection, X20 end plates (left and right) X20AC0SL1/X20AC0SR1 included	▮ 152
X20BB47	X20 Fieldbus CPU base, for Fieldbus CPU and Compact CPU supply module, base for integrated RS232 and CAN interface, 2x slots for X20 interface modules, X20 connection, X20 end plates (left and right), X20AC0SL1/X20AC0SR1 included	▮ 153



## Supply module PS9502



The supply module PS9502 is used together with an X20 Compact or Fieldbus CPU. It is equipped with a feed for the Compact or Fieldbus CPU, the X2X Link and the internal I/O supply.

The module is intended as a low-cost supply module for small X20 systems. Potential groups are able to be formed. An expansion or redundancy of the X2X Link with the PS3300 or PS3310 supply module is not possible. Expansion of the X20 system with a bus transmitter is not permitted either.

- Supply for the Compact or Fieldbus CPU, X2X Link, and internal I/O supply
- Low-cost supply module for small X20 systems
- No electrical isolation of feed and CPU / X2X Link supply
- Expansion or redundancy of CPU / X2X Link supply not possible by operating multiple supply modules simultaneously
- RS232 can be configured as an online interface
- CAN bus

<b>Short description</b>	<b>X20PS9502</b>
Power supply module	24 VDC supply module for Compact or Fieldbus CPU, X2X Link bus supply and I/O
Interfaces	1x RS232, 1x CAN bus <sup>1)</sup>
1) CAN bus only together with the X20BB27 or X20BB37 bus module.	
<b>CPU / X2X Link supply input</b>	<b>X20PS9502</b>
Input voltage	24 VDC (-15% / +20%)
Input current	Max. 0.7 A
Reverse polarity protection	Yes
Fuse	Integrated, cannot be exchanged
<b>CPU / X2X Link supply output</b>	<b>X20PS9502</b>
Rated output power	
Horizontal installation	7.0 W at 45°C and 5.0 W at 55°C
Vertical installation	7.0 W at 40°C and 5.0 W at 50°C
Parallel operation	No
Redundant operation of the CPU / X2X Link supply	No
<b>Input I/O supply</b>	<b>X20PS9502</b>
Input voltage	24 VDC (-15% / +20%)
Fuse	Recommended pre-fusing max. 10 A slow-blow
<b>Output I/O supply</b>	<b>X20PS9502</b>
Rated output voltage	24 VDC
Permitted contact load	10.0 A
<b>Interfaces</b>	<b>X20PS9502</b>
Interface IF1	
Type	RS232
Design	Contact via 12-pin terminal block TB12
Maximum transfer rate	115.2 kBit/s
Interface IF3 <sup>1)</sup>	
Type	CAN bus
Design	Contact via 12-pin terminal block TB12
Maximum transfer rate	1 MBit/s
1) CAN bus only together with the X20BB27 or X20BB37 bus module.	
<b>General information</b>	<b>X20PS9502</b>
Status indicators	Operating status, module status, RS232, CAN bus <sup>1)</sup>
Diagnostics	
Module run/error	Yes, with status LED and software status
Overload	Yes, with status LED and software status
RS232 data transfer	Yes, with status LED
CAN bus data transfer <sup>1)</sup>	Yes, with status LED
Electrical isolation	
CPU / X2X bus supply	No
I/O supply	No
Power consumption <sup>2)</sup>	
Bus	1.44 W
I/O internal	0.6 W
Certification	CE, C-UL-US (in development), GOST-R

1) CAN bus only together with the X20BB27 or X20BB37 bus module.

2) The specified values are maximum values. The exact calculation is available for download as a data sheet with the other module documentation on the B5R homepage.

<b>Operational conditions</b>	<b>X20PS9502</b>
Operating temperature	
Horizontal installation	0°C to +55°C
Vertical installation	0°C to +50°C
Relative humidity	5 to 95%, non-condensing
Mounting orientation	Horizontal or vertical
Installation at altitudes above sea level	
0 - 2000 m	No derating
>2000 m	Reduction of ambient temperature by 0.5°C per 100 m
Protection type	IP20
<b>Storage and transport conditions</b>	<b>X20PS9502</b>
Temperature	-25°C to +70°C
Relative humidity	5 to 95%, non-condensing
<b>Mechanical characteristics</b>	<b>X20PS9502</b>
Spacing	12.5 <sup>+0.2</sup> mm
Comment	Order terminal block 1x X20TB12 separately Order Compact CPU base 1x X20BB22 or X20BB27 separately Order Fieldbus CPU base 1x X20BB32 or X20BB37 separately

# Supply module PS9502

## Pin assignments

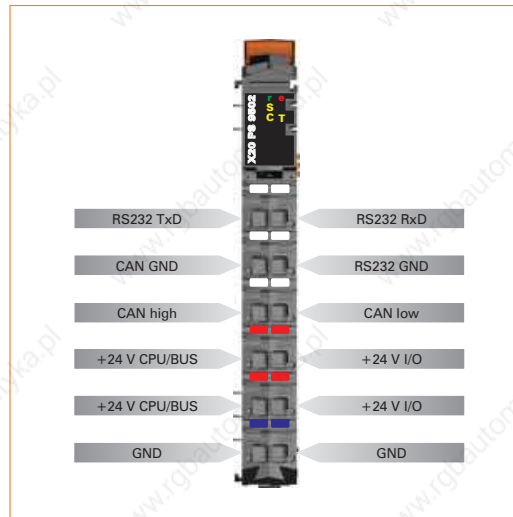

## Connection example

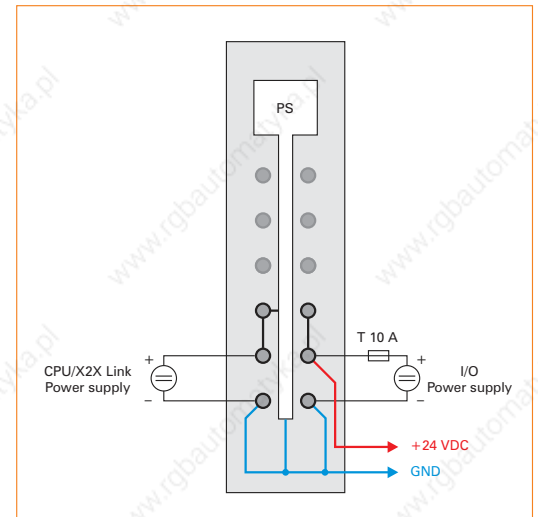

Required accessories		
X20TB12	X20 terminal block, 12-pin, 24 V coded	▮ 94
X20BB22	X20 Compact CPU base, for Compact CPU and Compact CPU supply module, base for integrated RS232 interface, X20 connection, X20 end plates (left and right), X20AC0SL1/X20AC0SR1 included	▮ 132
X20BB27	X20 Compact CPU base, for Compact CPU and Compact CPU supply module, base for integrated RS232 and CAN interfaces, X20 connection, X20 end plates (left and right), X20AC0SL1/X20AC0SR1 included	▮ 133
X20BB32	X20 Fieldbus CPU base, for Fieldbus CPU and Compact CPU supply module, base for integrated RS232 interface, slot for X20 interface module, X20 connection, X20 end plates (left and right), X20AC0SL1/X20AC0SR1 included	▮ 150
X20BB37	X20 Fieldbus CPU base, for Fieldbus CPU and Compact CPU supply module, base for integrated RS232 and CAN interface, slot for X20 interface module, X20 connection, X20 end plates (left and right), X20AC0SL1/X20AC0SR1 included	▮ 151
X20BB42	X20 Fieldbus CPU base, for Fieldbus CPU and Compact CPU supply module, base for integrated RS232 interface, 2 slots for X20 interface smodule, X20 connection, X20 end plates (left and right), X20AC0SL1/X20AC0SR1 included	▮ 152
X20BB47	X20 Fieldbus CPU base, for Fieldbus CPU and Compact CPU supply module, base for integrated RS232 and CAN interface, 2 slots for X20 interface modules, X20 connection, X20 end plates (left and right), X20AC0SL1/X20AC0SR1 included	▮ 153

# Fieldbus CPUs



## Adaptable to individual requirements

Fieldbus CPUs are a variation of Compact CPUs. Their modular structure makes it easy to meet the individual requirements of an application.

### Fieldbus CPU

- Embedded  $\mu$ P 25 with or without Ethernet on-board
- Embedded  $\mu$ P 16

### Interface module

- Profibus DP master
- Profibus DP slave
- CAN bus
- RS232
- RS485/RS422

### Bus module

- Bus module with RS232 connection
- Bus module with RS232 and CAN bus connections
- Both versions with one or two slots for interface modules

### Supply module

- Supply module for Fieldbus CPU, X2X Link bus supply and I/O
- RS232 interface connection
- CAN bus connection
- Without or without electrical isolation of the CPU/X2X Link supply

### Terminal block

- 12-pin terminal block

## The battery-free CPU

To meet the high demands of the market, the Fieldbus CPU was designed to run without a battery. This makes it completely maintenance-free. The following features make operation without a buffer battery possible.

### Real-time clock

The real-time clock is buffered for approx. 1000 hours by a gold foil capacitor.

### FRAM instead of SRAM for remanent variables

This FRAM stores its contents ferroelectrically. Unlike normal SRAM, this does not require a battery.

## Compact design

Despite the sleek profile of only 62.5 mm, the CPU supply, the X2X Link bus supply, and the I/O module supply are integrated in the CPU. No additional power supply modules are necessary.

# Fieldbus CPU XC0292



The structure of the X20 Fieldbus CPU is described on page 141. In addition to the structure, other general information is also provided.

Fieldbus CPUs are variations of Compact CPUs. In addition to these features, there is also the option of connecting fieldbus modules to the left side. These CPUs make applications possible in which data preprocessing has to take place remotely within the I/O bus connection.

Equipped with Embedded  $\mu$ P 25 and additional memory, the XC0292 is predestined for drive and visualization applications. Unlike XC0202, the XC0292 is equipped with an Ethernet on-board interface.

- Embedded  $\mu$ P 25
- 750 KB User SRAM
- 3 MB User FlashPROM
- Ethernet on-board
- Up to two slots for fieldbus modules
- Only 62.5 mm wide
- Battery-free



Short description	X20XC0292
System module	CPU
Processor	Embedded $\mu$ P 25
Interfaces	1x Ethernet onboard
<b>Controller</b>	<b>X20XC0292</b>
Fastest task class cycle time	2 ms
Typical instruction cycle time	0.5 $\mu$ s
Standard memory	
User RAM	750 KByte SRAM <sup>1)</sup>
User PROM	3 MB FlashPROM
Permanent variables	2.75 KByte FRAM <sup>2)</sup>
Backup battery	No
Integrated I/O processor	Processes I/O data points in the background
Real-time clock <sup>3)</sup>	Yes, resolution 1 s
Slots for fieldbus modules	
X20BB3x	1
X20BB4x	2

1) Not buffered.

2) The FRAM stores its contents ferromagnetically. Therefore, no buffer battery is needed.

3) The real-time clock is buffered for approx. 1000 hours by a gold foil capacitor. The gold foil capacitor is completely loaded after 18 continuous hours of operation.

<b>Interfaces</b>		<b>X20XC0292</b>
<b>Interface IF2</b>		
Type	Ethernet	
Design	Shielded RJ45 port	
Transfer rate	100 MBit/s	
Cable length	Max. 100 m between two stations (segment length)	
<b>Additional interfaces</b>		
X20BB32 and X20BB42	Fieldbus CPU base module with integrated RS232 interface	
X20BB37 and X20BB47	Fieldbus CPU base module with integrated RS232 and CAN interfaces	
<b>General information</b>		<b>X20XC0292</b>
Status indicators	CPU function, Ethernet	
<b>Diagnostics</b>		
CPU function	Yes, with status LED	
Ethernet	Yes, with status LED	
Over-temperature	Yes, with software status	
Visual Components capability	Yes	
ACOPOS capability	Yes	
Temperature sensor	Yes	
Power consumption	2.8 W	
Certification	CE, C-UL-US (in development), GOST-R	
<b>Operational conditions</b>		<b>X20XC0292</b>
<b>Operating temperature</b>		
Horizontal installation	0°C to +55°C	
Vertical installation	0°C to +50°C	
Relative humidity	5 to 95%, non-condensing	
Mounting orientation	Horizontal or vertical	
<b>Installation at altitudes above sea level</b>		
0 - 2000 m	No derating	
>2000 m	Reduction of ambient temperature by 0.5°C per 100 m	
Protection type	IP20	
<b>Storage and transport conditions</b>		<b>X20XC0292</b>
Temperature	-25°C to +70°C	
Relative humidity	5 to 95%, non-condensing	
<b>Mechanical characteristics</b>		<b>X20XC0292</b>
<b>Grid size <sup>1)</sup></b>		
X20BB3x	62.5 <sup>+0.2</sup> mm	
X20BB4x	87.5 <sup>+0.2</sup> mm	
Comment	Order terminal block 1x X20TB12 separately Order supply module 1x X20PS9500 or X20PS9502 separately Order Fieldbus CPU base 1x X20BB3x/4x separately	

<sup>1)</sup> Spacing is based on the width of the Fieldbus CPU base X20BB3x/4x. The CPU always requires up to two fieldbus modules and one supply module X20PS9500 or X20PS9502.

## Fieldbus CPU XC0292

Required accessories		
X20TB12	X20 terminal block, 12-pin, 24 V coded	94
X20BB32	X20 Fieldbus CPU base, for Fieldbus CPU and Compact CPU supply module, base for integrated RS232 interface, slot for X20 interface module, X20 connection, X20 end plates (left and right), X20AC0SL1/X20AC0SR1 included	150
X20BB37	X20 Fieldbus CPU base, for Fieldbus CPU and Compact CPU supply module, base for integrated RS232 and CAN interface, slot for X20 interface module, X20 connection, X20 end plates (left and right) X20AC0SL1/X20AC0SR1 included	151
X20BB42	X20 Fieldbus CPU base, for Fieldbus CPU and Compact CPU supply module, base for integrated RS232 interface, 2 slots for X20 interface smodule, X20 connection, X20 end plates (left and right), X20AC0SL1/X20AC0SR1 included	152
X20BB47	X20 Fieldbus CPU base, for Fieldbus CPU and Compact CPU supply module, base for integrated RS232 and CAN interface, 2 slots for X20 interface modules, X20 connection, X20 end plates (left and right), X20AC0SL1/X20AC0SR1 included	153
X20PS9500	X20 supply module for Compact and fieldbus CPUs and internal I/O supply, X2X Link bus supply	134
X20PS9502	X20 supply module for Compact and fieldbus CPUs and internal I/O supply, X2X Link bus supply, Supply not electrically isolated	138
Optional accessories		
X20IFxxx	Communication with CAN bus, Profibus DP, RS232, RS422, RS485	70



# Fieldbus CPU XC0202



The structure of the X20 Fieldbus CPU is described on page 141. In addition to the structure, other general information is also provided.

Fieldbus CPUs are variations of Compact CPUs. In addition to these features, there is also the option of connecting fieldbus modules to the left side. These CPUs make applications possible in which data preprocessing has to take place remotely within the I/O bus connection.

Equipped with Embedded  $\mu$ P 25 and additional memory, the XC0202 is predestined for drive and visualization applications.

- Embedded  $\mu$ P 25
- 750 KB User SRAM
- 3 MB User FlashPROM
- Up to two slots for fieldbus modules
- Only 62.5 mm wide
- Battery-free



Short description	X20XC0202
System module	CPU
Processor	Embedded $\mu$ P 25
<b>Controller</b>	<b>X20XC0202</b>
Fastest task class cycle time	2 ms
Typical instruction cycle time	0.5 $\mu$ s
Standard memory	
User RAM	750 KByte SRAM <sup>1)</sup>
User PROM	3 MB FlashPROM
Permanent variables	2.75 KByte FRAM <sup>2)</sup>
Backup battery	No
Integrated I/O processor	Processes I/O data points in the background
Real-time clock <sup>3)</sup>	Yes, resolution 1 s
Slots for fieldbus modules	
X20BB3x	1
X20BB4x	2

1) Not buffered.

2) The FRAM stores its contents ferromagnetically. Therefore, no buffer battery is needed.

3) The real-time clock is buffered for approx. 1000 hours by a gold foil capacitor. The gold foil capacitor is completely loaded after 18 continuous hours of operation.

Interfaces	X20XC0202
Interfaces (located on the base module)	
X20BB32 and X20BB42	Fieldbus CPU base module with integrated RS232 interface
X20BB37 and X20BB47	Fieldbus CPU base module with integrated RS232 and CAN interfaces

<b>General information</b>	<b>X20XC0202</b>
Status indicators	CPU function
Diagnostics	
CPU function	Yes, with status LED
Over-temperature	Yes, with software status
Visual Components capability	Yes
ACOPOS capability	Yes
Temperature sensor	Yes
Power consumption	2.2 W
Certification	CE, C-UL-US, GOST-R
<b>Operational conditions</b>	<b>X20XC0202</b>
Operating temperature	
Horizontal installation	0°C to +55°C
Vertical installation	0°C to +50°C
Relative humidity	5 to 95%, non-condensing
Mounting orientation	Horizontal or vertical
Installation at altitudes above sea level	
0 - 2000 m	No derating
>2000 m	Reduction of ambient temperature by 0.5°C per 100 m
Protection type	IP20
<b>Storage and transport conditions</b>	<b>X20XC0202</b>
Temperature	-25°C to +70°C
Relative humidity	5 to 95%, non-condensing
<b>Mechanical characteristics</b>	<b>X20XC0202</b>
Grid size <sup>1)</sup>	
X20BB3x	62.5 <sup>+0.2</sup> mm
X20BB4x	87.5 <sup>+0.2</sup> mm
Comment	Order terminal block 1x X20TB12 separately Order supply module 1x X20PS9500 or X20PS9502 separately Order Fieldbus CPU base 1x X20BB3x/4x separately

<sup>1)</sup> Spacing is based on the width of the Fieldbus CPU base X20BB3x/4x. The CPU always requires up to two fieldbus modules and one supply module X20PS9500 or X20PS9502.

<b>Required accessories</b>		
X20TB12	X20 terminal block, 12-pin, 24 V coded	94
X20BB32	X20 Fieldbus CPU base, for Fieldbus CPU and Compact CPU supply module, base for integrated RS232 interface, slot for X20 interface module, X20 connection, X20 end plates (left and right), X20AC0SL1/X20AC0SR1 included	150
X20BB37	X20 Fieldbus CPU base, for Fieldbus CPU and Compact CPU supply module, base for integrated RS232 and CAN interface, slot for X20 interface module, X20 connection, X20 end plates (left and right), X20AC0SL1/X20AC0SR1 included	151
X20BB42	X20 Fieldbus CPU base, for Fieldbus CPU and Compact CPU supply module, base for integrated RS232 interface, 2x slots for X20 interface module, X20 connection, X20 end plates (left and right) X20AC0SL1/X20AC0SR1 included	152
X20BB47	X20 Fieldbus CPU base, for Fieldbus CPU and Compact CPU supply module, base for integrated RS232 and CAN interface, 2x slots for X20 interface module, X20 connection, X20 end plates (left and right) X20AC0SL1/X20AC0SR1 included	153
X20PS9500	X20 supply module for Compact and fieldbus CPUs and internal I/O supply, X2X Link bus supply	134
X20PS9502	X20 supply module for Compact and fieldbus CPUs and internal I/O supply, X2X Link bus supply, supply feed not electrically isolated	138
<b>Optional accessories</b>		
X20IFxxxx	Communication with CAN bus, Profibus DP, RS232, RS422, RS485	70

# Fieldbus CPU XC0201



The structure of the X20 Fieldbus CPU is described on page 141. In addition to the structure, other general information is also provided.

Fieldbus CPUs are variations of Compact CPUs. In addition to these features, there is also the option of connecting fieldbus modules to the left side. These CPUs make applications possible in which data preprocessing has to take place remotely within the I/O bus connection.

The XC201 is the entry-level X20 Fieldbus CPU. This CPU is used when a cycle time of 2 ms (typ. 5 ms) is sufficient and the cost/performance ratio is a key factor.

- Embedded  $\mu$ P 16
- 100 KB User SRAM
- 1 MB User FlashPROM
- Up to two slots for fieldbus modules
- Only 62.5 mm wide
- Battery-free



Short description	X20XC0201
System module	CPU
Processor	Embedded $\mu$ P 16
<b>Controller</b>	<b>X20XC0201</b>
Fastest task class cycle time	4 ms
Typical instruction cycle time	0.8 $\mu$ s
Standard memory	
User RAM	100 KByte SRAM <sup>1)</sup>
User PROM	1 MB FlashPROM
Permanent variables	2.75 KByte FRAM <sup>2)</sup>
Backup battery	No
Integrated I/O processor	Processes I/O data points in the background
Real-time clock <sup>3)</sup>	Yes, resolution 1 s
Slots for fieldbus modules	
X20BB3x	1
X20BB4x	2

1) Not buffered.

2) The FRAM stores its contents ferromagnetically. Therefore, no buffer battery is needed.

3) The real-time clock is buffered for approx. 1000 hours by a gold foil capacitor. The gold foil capacitor is completely loaded after 18 continuous hours of operation.

Interfaces	X20XC0201
Interfaces (located on the base module)	
X20BB32 and X20BB42	Fieldbus CPU base module with integrated RS232 interface
X20BB37 and X20BB47	Fieldbus CPU base module with integrated RS232 and CAN interfaces

<b>General information</b>	<b>X20XC0201</b>
Status indicators	CPU function
Diagnostics	
CPU function	Yes, with status LED
Visual Components capability	Limited (User PROM)
ACOPOS capability	Limited (User PROM)
Temperature sensor	No
Power consumption	2.0 W
Certification	CE, C-UL-US, GOST-R
<b>Operational conditions</b>	<b>X20XC0201</b>
Operating temperature	
Horizontal installation	0°C to +55°C
Vertical installation	0°C to +50°C
Relative humidity	5 to 95%, non-condensing
Mounting orientation	Horizontal or vertical
Installation at altitudes above sea level	
0 - 2000 m	No derating
>2000 m	Reduction of ambient temperature by 0.5°C per 100 m
Protection type	IP20
<b>Storage and transport conditions</b>	<b>X20XC0201</b>
Temperature	-25°C to +70°C
Relative humidity	5 to 95%, non-condensing
<b>Mechanical characteristics</b>	<b>X20XC0201</b>
Grid size <sup>1)</sup>	
X20BB3x	62.5 <sup>+0.2</sup> mm
X20BB4x	87.5 <sup>+0.2</sup> mm
Comment	Order terminal block 1x X20TB12 separately Order supply module 1x X20PS9500 or X20PS9502 separately Order Fieldbus CPU base 1x X20BB3x/4x separately

1) Spacing is based on the width of the Fieldbus CPU base X20BB3x/4x. The CPU always requires up to two fieldbus modules and one supply module X20PS9500 or X20PS9502.

<b>Required accessories</b>		
X20TB12	X20 terminal block, 12-pin, 24 V coded	94
X20BB32	X20 Fieldbus CPU base, for Fieldbus CPU and Compact CPU supply module, base for integrated RS232 interface, slot for X20 interface module, X20 connection, X20 end plates (left and right), X20AC0SL1/X20AC0SR1 included	150
X20BB37	X20 Fieldbus CPU base, for Fieldbus CPU and Compact CPU supply module, base for integrated RS232 and CAN interface, slot for X20 interface module, X20 connection, X20 end plates (left and right), X20AC0SL1/X20AC0SR1 included	151
X20BB42	X20 Fieldbus CPU base, for Fieldbus CPU and Compact CPU supply module, base for integrated RS232 interface, 2x slots for X20 interface module, X20 connection, X20 end plates (left and right) X20AC0SL1/X20AC0SR1 included	152
X20BB47	X20 Fieldbus CPU base, for Fieldbus CPU and Compact CPU supply module, base for integrated RS232 and CAN interface, 2x slots for X20 interface module, X20 connection, X20 end plates (left and right) X20AC0SL1/X20AC0SR1 included	153
X20PS9500	X20 supply module for Compact and fieldbus CPUs and internal I/O supply, X2X Link bus supply	134
X20PS9502	X20 supply module for Compact and fieldbus CPUs and internal I/O supply, X2X Link bus supply, supply feed not electrically isolated	138
<b>Optional accessories</b>		
X20IFxxxx	Communication with CAN bus, Profibus DP, RS232, RS422, RS485	70

# Bus module BB32



The BB32 bus module is the base for all X20 Fieldbus CPUs. The left and right locking plates are included in the delivery.

- Base for all X20 Fieldbus CPUs
- RS232 connection

<b>Short description</b>	<b>X20BB32</b>
Bus module	X20 Fieldbus CPU base, backplane for Fieldbus CPU, Fieldbus CPU supply module and interface module
Interfaces	1x RS232 connection
<b>General information</b>	<b>X20BB32</b>
Electrical isolation	
Bus - RS232	No
Power consumption	
Bus	0.35 W
I/O internal	-
Certification	CE, C-UL-US, GOST-R
<b>Operational conditions</b>	<b>X20BB32</b>
Operating temperature	
Horizontal installation	0°C to +55°C
Vertical installation	0°C to +50°C
Relative humidity	5 to 95%, non-condensing
Mounting orientation	Horizontal or vertical
Installation at altitudes above sea level	
0 - 2000 m	No derating
>2000 m	Reduction of ambient temperature by 0.5°C per 100 m
Protection type	IP20
<b>Storage and transport conditions</b>	<b>X20BB32</b>
Temperature	-25°C to +70°C
Relative humidity	5 to 95%, non-condensing
<b>Mechanical characteristics</b>	<b>X20BB32</b>
Spacing	62.5 <sup>+0.2</sup> mm
Comment	Left and right X20 end plates included in delivery

## Potential control

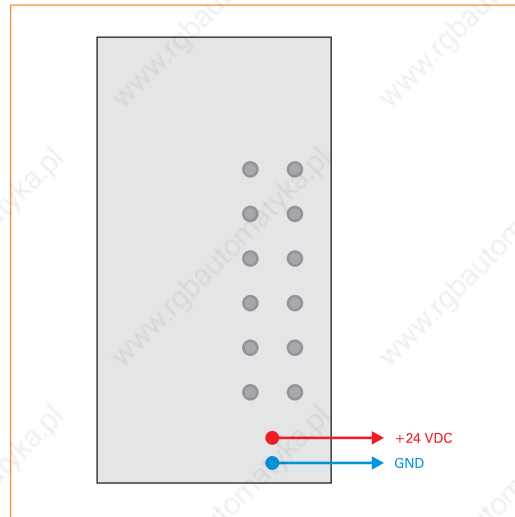

# Bus module BB37



The BB37 bus module is the base for all X20 Fieldbus CPUs. The left and right locking plates are included in the delivery.

- Base for all X20 Fieldbus CPUs
- RS232 connection
- CAN bus connection
- Integrated terminating resistor for CAN bus

<b>Short description</b>	<b>X20BB37</b>
Bus module	X20 Fieldbus CPU base, backplane for Fieldbus CPU, Fieldbus CPU supply module and interface module
Interfaces	1x RS232 connection, 1x CAN bus connection
<b>General information</b>	<b>X20BB37</b>
Electrical isolation	
Bus - RS232	No
Bus - CAN bus	No
RS232 - CAN bus	No
Power consumption	
Bus	0.56 W
I/O internal	-
Certification	CE, C-UL-US (in development), GOST-R
<b>Operational conditions</b>	<b>X20BB37</b>
Operating temperature	
Horizontal installation	0°C to +55°C
Vertical installation	0°C to +50°C
Relative humidity	5 to 95%, non-condensing
Mounting orientation	Horizontal or vertical
Installation at altitudes above sea level	
0 - 2000 m	No derating
>2000 m	Reduction of ambient temperature by 0.5°C per 100 m
Protection type	IP20
<b>Storage and transport conditions</b>	<b>X20BB37</b>
Temperature	-25°C to +70°C
Relative humidity	5 to 95%, non-condensing
<b>Mechanical characteristics</b>	<b>X20BB37</b>
Spacing	62.5 <sup>+0.2</sup> mm
Comment	Left and right X20 end plates included in delivery

## Potential control

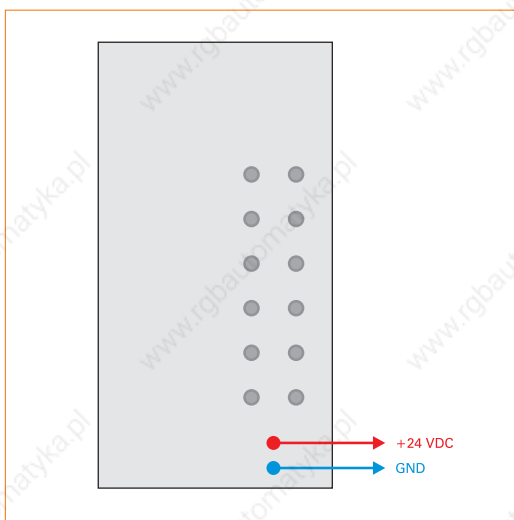

# Bus module BB42



The BB42 bus module is a base for all X20 Fieldbus CPUs. It is equipped with two slots for interface modules. The left and right locking plates are included in the delivery.

- Base for all X20 Fieldbus CPUs
- Two slots for interface modules
- RS232 connection

<b>Short description</b>	<b>X20BB42</b>
Bus module	X20 Fieldbus CPU base, backplane for Fieldbus CPU, Fieldbus CPU supply module and two interface modules
Interfaces	1x RS232 connection
<b>General information</b>	<b>X20BB42</b>
Electrical isolation	
Bus - RS232	No
Power consumption	
Bus	TBD
I/O internal	-
Certification	CE, C-UL-US (in development), GOST-R
<b>Operational conditions</b>	<b>X20BB42</b>
Operating temperature	
Horizontal installation	0°C to +55°C
Vertical installation	0°C to +50°C
Relative humidity	5 to 95%, non-condensing
Mounting orientation	Horizontal or vertical
Installation at altitudes above sea level	
0 - 2000 m	No derating
>2000 m	Reduction of ambient temperature by 0.5°C per 100 m
Protection type	IP20
<b>Storage and transport conditions</b>	<b>X20BB42</b>
Temperature	-25°C to +70°C
Relative humidity	5 to 95%, non-condensing
<b>Mechanical characteristics</b>	<b>X20BB42</b>
Spacing	87.5 <sup>+0.2</sup> mm
Comment	Left and right X20 end plates included in delivery

## Potential control

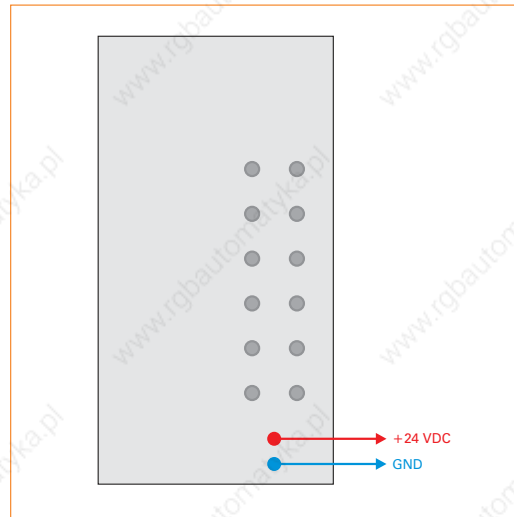

# Bus module BB47



The BB47 bus module is a base for all X20 Fieldbus CPUs. It is equipped with two slots for interface modules. The left and right locking plates are included in the delivery.

- Base for all X20 Fieldbus CPUs
- Two slots for interface modules
- RS232 connection
- CAN bus connection
- Integrated terminating resistor for CAN bus

<b>Short description</b>	<b>X20BB47</b>
Bus module	X20 Fieldbus CPU base, backplane for Fieldbus CPU, Fieldbus CPU supply module and two interface modules
Interfaces	1x RS232 connection, 1x CAN bus connection
<b>General information</b>	<b>X20BB47</b>
Electrical isolation	
Bus - RS232	No
Bus - CAN bus	No
RS232 - CAN bus	No
Power consumption	
Bus	TBD
I/O internal	-
Certification	CE, C-UL-US (in development), GOST-R
<b>Operational conditions</b>	<b>X20BB47</b>
Operating temperature	
Horizontal installation	0°C to +55°C
Vertical installation	0°C to +50°C
Relative humidity	5 to 95%, non-condensing
Mounting orientation	Horizontal or vertical
Installation at altitudes above sea level	
0 - 2000 m	No derating
>2000 m	Reduction of ambient temperature by 0.5°C per 100 m
Protection type	IP20
<b>Storage and transport conditions</b>	<b>X20BB47</b>
Temperature	-25°C to +70°C
Relative humidity	5 to 95%, non-condensing
<b>Mechanical characteristics</b>	<b>X20BB47</b>
Spacing	87.5 <sup>+0.2</sup> mm
Comment	Left and right X20 end plates included in delivery

## Potential control

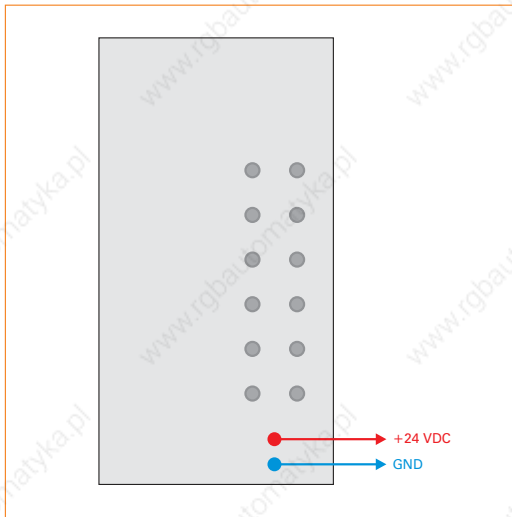

## Interface module IF1074



The IF1074 module is an interface module for the X20 fieldbus CPU.

- CAN bus connection
- Integrated terminating resistor

# CAN

<b>Short description</b>	<b>X20IF1074</b>
Communication module	1x CAN bus
<b>Interfaces</b>	<b>X20IF1074</b>
Interface IF1	
Type	CAN bus
Design	5-pin multipoint connector
Maximum transfer rate	1 MBit/s
<b>General information</b>	<b>X20IF1074</b>
Status indicators	Module status, data transfer, terminating resistor
Diagnostics	
Module status	Yes, with status LED
Data transfer	Yes, with status LED
Terminating resistor	Yes, with status LED
Electrical isolation	
PLC - IF1	Yes
Power consumption	0.69 W
Certification	CE, C-UL-US (in development), GOST-R
<b>Operational conditions</b>	<b>X20IF1074</b>
Operating temperature	
Horizontal installation	0°C to +55°C
Vertical installation	0°C to +50°C
Relative humidity	
	5 to 95%, non-condensing
Mounting orientation	
	Horizontal or vertical
Installation at altitudes above sea level	
0 - 2000 m	No derating
>2000 m	Reduction of ambient temperature by 0.5°C per 100 m
Protection type	IP20
<b>Storage and transport conditions</b>	<b>X20IF1074</b>
Temperature	-25°C to +70°C
Relative humidity	5 to 95%, non-condensing
<b>Mechanical characteristics</b>	<b>X20IF1074</b>
Slot	In X20 fieldbus CPU
Comment	Order 1x TB2105 terminal block separately

Required accessories		
0TB2105.9010	Accessory terminal block, 5-pin, screw clamp, 1.5 mm <sup>2</sup>	681
0TB2105.9110	Accessory terminal block, 5-pin, cage clamp, 2.5 mm <sup>2</sup>	681

# Bus controller

## X20 bus controllers

The bus controllers are a continuation of the completely modular strategy used for the I/O slices. Made up of a base module, a supply module to supply the voltage for the entire system, and a fieldbus interface, the bus controller is an extremely flexible fieldbus connection.

The entire backplane can be preinstalled. With the removable terminals, the entire system can be wired separately from the electronics module. The individual modules are put in place during commissioning. This is where the I/O system is adapted to the fieldbus being used. Unlike the Compact CPU with integrated fieldbus connection, the bus controller does not need to be programmed in order to transfer or receive the I/O data on the fieldbus. It can be configured on the fieldbus master.

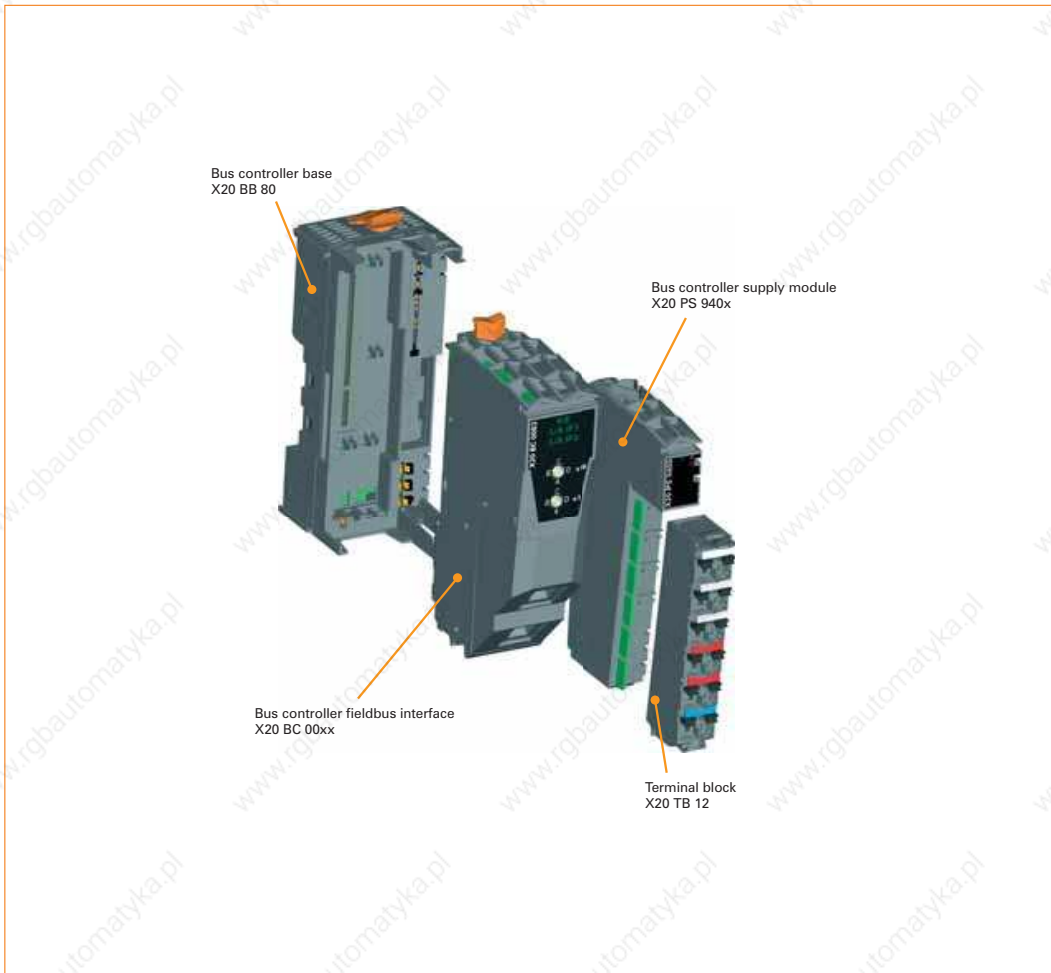

# CANopen bus controller BC0043



The structure of the X20 bus controller is described on page 155. In addition to the structure, other general information is also provided.

CAN (Controller Area Network) has spread considerably in automation technology. CAN topology is based on a line structure and uses twisted pair wires for data transfer. CANopen is a higher-layer protocol based on CAN. This standardized protocol offers highly flexible configuration possibilities.

The BC0043 bus controller makes it possible to connect X2X Link I/O nodes to CANopen. It has automatic transfer rate detection and auto-mapping of the I/O modules connected with X2X Link. All CANopen operating modes such as synchronous, event, and polling modes are supported together with PDO linking, life/node guarding, emergency objects, and much more.

- Fieldbus: CANopen
- I/O configuration via the fieldbus
- 20 Receive PDOs and 20 Transmit PDOs
- Select between entry of a fixed transfer rate or automatic transfer rate detection.
- Integrated terminating resistor



<b>Short description</b>	<b>X20BC0043</b>
Bus controller	CANopen
<b>Fieldbus</b>	<b>X20BC0043</b>
Type	CANopen
Design	5-pin multipoint connector
Maximum distance	1000 m
Maximum transfer rate	1 MBit/s
Determination of transfer rate	Automatic transfer rate detection or fixed rate setting
<b>General information</b>	<b>X20BC0043</b>
Status indicators	Module status, bus function, data transfer, terminating resistor
<b>Diagnostics</b>	
Module status	Yes, with status LED and software status
Bus function	Yes, with status LED
Data transfer	Yes, with status LED
Terminating resistor	Yes, with status LED
<b>Electrical isolation</b>	
Fieldbus - X2X bus	No
Fieldbus - I/O	Yes
Power consumption of the bus	1.5 W
Certification	CE, C-UL-US, GOST-R



<b>Operational conditions</b>	<b>X20BC0043</b>
Operating temperature	
Horizontal installation	0°C to +55°C
Vertical installation	0°C to +50°C
Relative humidity	5 to 95%, non-condensing
Mounting orientation	Horizontal or vertical
Installation at altitudes above sea level	
0 - 2000 m	No derating
>2000 m	Reduction of ambient temperature by 0.5°C per 100 m
Protection type	IP20
<b>Storage and transport conditions</b>	<b>X20BC0043</b>
Temperature	-25°C to +70°C
Relative humidity	5 to 95%, non-condensing
<b>Mechanical characteristics</b>	<b>X20BC0043</b>
Grid size <sup>1)</sup>	37.5 <sup>+0.2</sup> mm
Comment	Order 1x TB2105 terminal block separately Order terminal block 1x X20TB12 separately Order supply module 1x X20PS9400 or X20PS9402 separately Order 1x X20BB80 bus base separately

1) The spacing is based on the width of the X20BB80 bus base. An X20PS9400 or X20PS9402 supply module is also always required for the bus controller.

**Note:** This bus controller only supports the default function model of multi-function modules. The default function model is explained in the description for each multi-function module.

Required accessories		
0TB2105.9010	Accessory terminal block, 5-pin, screw clamp, 1.5 mm <sup>2</sup>	▣ 681
0TB2105.9110	Accessory terminal block, 5-pin, cage clamps, 2.5 mm <sup>2</sup>	▣ 681
X20TB12	X20 terminal block, 12-pin, 24 V coded	▣ 94
X20PS9400	X20 supply module for bus controller and internal I/O supply, X2X link bus supply	▣ 172
X20PS9402	X20 supply module for bus controller and internal I/O supply, X2X link bus supply, Supply not electrically isolated	▣ 174
X20BB80	X20 bus base, for X20 base module (BC, HB, etc.) and X20 supply module, X20 end plates (left and right) X20AC0SL1/X20AC0SR1 included	▣ 170

## DeviceNet bus controller BC0053



The structure of the X20 bus controller is described on page 155. In addition to the structure, other general information is also provided.

DeviceNet was developed by Allen Bradley as a CAN bus based automation network. It is based on a producer/consumer protocol. From the user's point of view, all data is handled separately from CAN bus transfer possibilities (e.g. longer data packets are automatically fragmented by DeviceNet). Access occurs using I/O messages with defined properties.

The BC0053 bus controller makes it possible to connect X2X Link I/O nodes to DeviceNet. It has automatic transfer rate detection and auto-mapping of the I/O modules connected with X2X Link. Explicit messaging, change of state, cyclic, polled and bit strobe are supported as DeviceNet operating modes. In addition to the standard communication objects, there are also a number of manufacturer-specific objects.

X20 or other modules that are based on X2X Link can be connected to the bus controller. The entire configuration of this type of modular system is supported by the DeviceNet standard. Allen Bradley developed this modular I/O configuration to simplify the necessary configuration steps and to achieve the required configuration of a modular DeviceNet device intuitively on a flat and very user-friendly interface. The X20 DeviceNet bus controller from B&R also supports this type of configuration.

- Fieldbus: DeviceNet
- I/O configuration via the fieldbus
- Support of both linear and modular systems (Allen Bradley)
- Integrated terminating resistor



<b>Short description</b>	<b>X20BC0053</b>
Bus controller	DeviceNet
<b>Fieldbus</b>	<b>X20BC0053</b>
Type	DeviceNet
Design	5-pin multipoint connector
Maximum distance	500 m at 125 kBit/sec
Maximum transfer rate	500 kBit/s
Determination of transfer rate	Automatic transfer rate detection
<b>General information</b>	<b>X20BC0053</b>
Status indicators	Module status, bus function, 24 V DeviceNet voltage, data transfer, terminating resistor
<b>Diagnostics</b>	
Module status	Yes, with status LED and software status
Bus function	Yes, with status LED
24 V DeviceNet voltage	Yes, with status LED
Data transfer	Yes, with status LED
Terminating resistor	Yes, with status LED
<b>Electrical isolation</b>	
Fieldbus - X2X bus	No
Fieldbus - I/O	Yes
Power consumption of the bus	1.5 W
Certification	CE, C-UL-US, GOST-R



<b>Operational conditions</b>	<b>X20BC0053</b>
Operating temperature	
Horizontal installation	0°C to +55°C
Vertical installation	0°C to +50°C
Relative humidity	5 to 95%, non-condensing
Mounting orientation	Horizontal or vertical
Installation at altitudes above sea level	
0 - 2000 m	No derating
>2000 m	Reduction of ambient temperature by 0.5°C per 100 m
Protection type	IP20
<b>Storage and transport conditions</b>	<b>X20BC0053</b>
Temperature	-25°C to +70°C
Relative humidity	5 to 95%, non-condensing
<b>Mechanical characteristics</b>	<b>X20BC0053</b>
Grid size <sup>1)</sup>	37.5 <sup>+0.2</sup> mm
Comment	Order 1x TB2105 terminal block separately Order terminal block 1x X20TB12 separately Order supply module 1x X20PS9400 or X20PS9402 separately Order 1x X20BB80 bus base separately

1) The spacing is based on the width of the X20BB80 bus base. An X20PS9400 or X20PS9402 supply module is also always required for the bus controller.

**Note:** This bus controller only supports the default function model of multi-function modules. The default function model is explained in the description for each multi-function module.

<b>Required accessories</b>		
0TB2105.9010	Accessory terminal block, 5-pin, screw clamp, 1.5 mm <sup>2</sup>	▣ 681
0TB2105.9110	Accessory terminal block, 5-pin, cage clamps, 2.5 mm <sup>2</sup>	▣ 681
X20TB12	X20 terminal block, 12-pin, 24 V coded	▣ 94
X20PS9400	X20 supply module for bus controller and internal I/O supply, X2X link bus supply	▣ 172
X20PS9402	X20 supply module for bus controller and internal I/O supply, X2X link bus supply, Supply not electrically isolated	▣ 174
X20BB80	X20 bus base, for X20 base module (BC, HB, etc.) and X20 supply module, X20 end plates (left and right) X20AC0SL1/X20AC0SR1 included	▣ 170

## Profibus DP bus controller BC0063



The structure of the X20 bus controller is described on page 155. In addition to the structure, other general information is also provided.

Profibus DP is based on the physics of the RS485 interface. Data transfer is controlled using a hybrid bus access procedure. Active stations receive communication rights via a token passing procedure and can then access all stations on the network according to the master-slave principle. The maximum time of circulation for a token can be configured, which results in a defined cycle time.

Access represents various services for the user, for cyclic and for acyclic data transfer.

The BC0063 bus controller makes it possible to connect X2X Link I/O nodes to Profibus DP. It supports Profibus DP with all of its options and other additional properties. In addition to the device, module, and channel diagnostics provided in the Profibus standard, it is also possible, for example, to switch to the slot diagnostics option in S7 format. X20 or other modules that are based on X2X Link can be connected to the bus controller. The modular system configuration is optimally supported by Profibus DP.

- Fieldbus: Profibus DP
- I/O configuration via the fieldbus
- Extensive device, module, and channel diagnosis according to Profibus DP standard
- Communication with X2X Link I/O nodes even works when some nodes are missing or without power



<b>Short description</b>	<b>X20BC0063</b>
Bus controller	Profibus DP slave
<b>Fieldbus</b>	<b>X20BC0063</b>
Type	Profibus DP slave
Design	9-pin DSUB socket
Maximum distance	See Profibus DP specifications
Maximum transfer rate	12 MBit/s
Determination of transfer rate	Automatic transfer rate detection
<b>General information</b>	<b>X20BC0063</b>
Status indicators	Module status, bus function, data transfer
<b>Diagnostics</b>	
Module status	Yes, with status LED and software status
Bus function	Yes, with status LED
Data transfer	Yes, with status LED
<b>Electrical isolation</b>	
Fieldbus - X2X bus	No
Fieldbus - I/O	Yes
Power consumption of the bus	2.3 W
Certification	CE, C-UL-US, GOST-R



<b>Operational conditions</b>	<b>X20BC0063</b>
Operating temperature	
Horizontal installation	0°C to +55°C
Vertical installation	0°C to +50°C
Relative humidity	5 to 95%, non-condensing
Mounting orientation	Horizontal or vertical
Installation at altitudes above sea level	
0 - 2000 m	No derating
>2000 m	Reduction of ambient temperature by 0.5°C per 100 m
Protection type	IP20
<b>Storage and transport conditions</b>	<b>X20BC0063</b>
Temperature	-25°C to +70°C
Relative humidity	5 to 95%, non-condensing
<b>Mechanical characteristics</b>	<b>X20BC0063</b>
Grid size <sup>1)</sup>	37.5 <sup>+0.2</sup> mm
Comment	Order terminal block 1x X20TB12 separately Order supply module 1x X20PS9400 or X20PS9402 separately Order 1x X20BB80 bus base separately

1) The spacing is based on the width of the X20BB80 bus base. An X20PS9400 or X20PS9402 supply module is also always required for the bus controller.

**Note:** This bus controller only supports the default function model of multi-function modules. The default function model is explained in the description for each multi-function module.

<b>Required accessories</b>		
X20TB12	X20 terminal block, 12-pin, 24 V coded	▣ 94
X20PS9400	X20 supply module for bus controller and internal I/O supply, X2X link bus supply	▣ 172
X20PS9402	X20 supply module for bus controller and internal I/O supply, X2X link bus supply, Supply not electrically isolated	▣ 174
X20BB80	X20 bus base, for X20 base module (BC, HB, etc.) and X20 supply module, X20 end plates (left and right) X20AC0SL1/X20AC0SR1 included	▣ 170
<b>Optional accessories</b>		
0G1000.00-090	Bus connector, RS485, for Profibus networks	▣ 690

## CAN I/O bus controller BC0073



The structure of the X20 bus controller is described on page 155. In addition to the structure, other general information is also provided.

The bus controller BC0073 lets you connect X2X Link I/O nodes to CAN I/O. CAN I/O is a transfer protocol based on the CAN bus standard and is fully integrated into the B&R system. From the user's point of view, it doesn't matter if I/O points are operated locally or remotely via CAN I/O.

Up to 43 I/O modules can be connected to the bus controller. Up to 16 of them can be analog modules.

- Fieldbus: CAN bus
- Automatic firmware update via the fieldbus
- Integrated I/O access in B&R Automation Studio
- Integrated terminating resistor



<b>Short description</b>	<b>X20BC0073</b>
Bus controller	CAN I/O slave
<b>Fieldbus</b>	<b>X20BC0073</b>
Type	CAN I/O slave
Design	5-pin multipoint connector
Maximum distance	1000 m
Maximum transfer rate	1 MBit/s
Determination of transfer rate	Automatic transfer rate detection, permanently set or from internal EEPROM
<b>General information</b>	<b>X20BC0073</b>
Status indicators	Module status, bus function, data transfer, terminating resistor
<b>Diagnostics</b>	
Module status	Yes, with status LED and software status
Bus function	Yes, with status LED
Data transfer	Yes, with status LED
Terminating resistor	Yes, with status LED
<b>Electrical isolation</b>	
Fieldbus - X2X bus	No
Fieldbus - I/O	Yes
Power consumption of the bus	1.5 W
Certification	CE, C-UL-US, GOST-R

# CAN

<b>Operational conditions</b>	<b>X20BC0073</b>
Operating temperature	
Horizontal installation	0°C to +55°C
Vertical installation	0°C to +50°C
Relative humidity	5 to 95%, non-condensing
Mounting orientation	Horizontal or vertical
Installation at altitudes above sea level	
0 - 2000 m	No derating
>2000 m	Reduction of ambient temperature by 0.5°C per 100 m
Protection type	IP20
<b>Storage and transport conditions</b>	<b>X20BC0073</b>
Temperature	-25°C to +70°C
Relative humidity	5 to 95%, non-condensing
<b>Mechanical characteristics</b>	<b>X20BC0073</b>
Grid size <sup>1)</sup>	37.5 <sup>+0.2</sup> mm
Comment	Order 1x TB2105 terminal block separately Order terminal block 1x X20TB12 separately Order supply module 1x X20PS9400 or X20PS9402 separately Order 1x X20BB80 bus base separately

1) The spacing is based on the width of the X20BB80 bus base. An X20PS9400 or X20PS9402 supply module is also always required for the bus controller.

**Note:** This bus controller only supports the default function model of multi-function modules. The default function model is explained in the description for each multi-function module.

Required accessories		
0TB2105.9010	Accessory terminal block, 5-pin, screw clamp, 1.5 mm <sup>2</sup>	▣ 681
0TB2105.9110	Accessory terminal block, 5-pin, cage clamps, 2.5 mm <sup>2</sup>	▣ 681
X20TB12	X20 terminal block, 12-pin, 24 V coded	▣ 94
X20PS9400	X20 supply module for bus controller and internal I/O supply, X2X link bus supply	▣ 172
X20PS9402	X20 supply module for bus controller and internal I/O supply, X2X link bus supply, Supply not electrically isolated	▣ 174
X20BB80	X20 bus base, for X20 base module (BC, HB, etc.) and X20 supply module, X20 end plates (left and right) X20AC0SL1/X20AC0SR1 included	▣ 170

## Ethernet POWERLINK bus controller BC0083



The structure of the X20 bus controller is described on page 155. In addition to the structure, other general information is also provided.

The BC0083 bus controller makes it possible to connect X2X Link I/O nodes to POWERLINK V1/V2. It is also possible to operate the X2X Link cycle synchronously 1:1 and synchronous to POWERLINK using a prescaler.

POWERLINK is a standard protocol for Fast Ethernet with true real-time properties. The Ethernet POWERLINK Standardization Group (EPSG, [www.ethernet-powerlink.org](http://www.ethernet-powerlink.org)) ensures that the standard remains open and is continually developed.

- POWERLINK V1/V2
- I/O configuration and firmware update via the fieldbus
- Integrated hub for efficient cabling



<b>Short description</b>	<b>X20BC0083</b>
Bus controller	POWERLINK V1/V2 controlled node
<b>Fieldbus</b>	<b>X20BC0083</b>
Type	POWERLINK V1/V2 100 Base-T (ANSI/IEE 802.3)
Design	Internal 2x hub, 2x shielded RJ45 port
Cable length	Max. 100 m between two stations (segment length)
Transfer rate	100 MBit/s
<b>General information</b>	<b>X20BC0083</b>
Status indicators	Module status, bus function
Diagnostics	
Module status	Yes, with status LED and software status
Bus function	Yes, with status LED and software status
Electrical isolation	
Fieldbus - X2X bus	Yes
Fieldbus - I/O	Yes
Power consumption of the bus	2.0 W
Certification	CE, C-UL-US, GOST-R

ETHERNET   
**POWERLINK**

<b>Operational conditions</b>	<b>X20BC0083</b>
Operating temperature	
Horizontal installation	0°C to +55°C
Vertical installation	0°C to +50°C
Relative humidity	5 to 95%, non-condensing
Mounting orientation	Horizontal or vertical
Installation at altitudes above sea level	
0 - 2000 m	No derating
>2000 m	Reduction of ambient temperature by 0.5°C per 100 m
Protection type	IP20
<b>Storage and transport conditions</b>	<b>X20BC0083</b>
Temperature	-25°C to +70°C
Relative humidity	5 to 95%, non-condensing
<b>Mechanical characteristics</b>	<b>X20BC0083</b>
Grid size <sup>1)</sup>	37.5 <sup>+0.2</sup> mm
Comment	Order terminal block 1x X20TB12 separately Order supply module 1x X20PS9400 or X20PS9402 separately Order 1x X20BB80 bus base separately

1) The spacing is based on the width of the X20BB80 bus base. An X20PS9400 or X20PS9402 supply module is also always required for the bus controller.

Required accessories		
X20TB12	X20 terminal block, 12-pin, 24 V coded	▣ 94
X20PS9400	X20 supply module for bus controller and internal I/O supply, X2X link bus supply	▣ 172
X20PS9402	X20 supply module for bus controller and internal I/O supply, X2X link bus supply, Supply not electrically isolated	▣ 174
X20BB80	X20 bus base, for X20 base module (BC, HB, etc.) and X20 supply module, X20 end plates (left and right) X20AC0SL1/X20AC0SR1 included	▣ 170

## Bus controller Modbus/TCP BC0087



The structure of the X20 bus controller is described on page 155. In addition to the structure, other general information is also provided.

Ethernet TCP/IP has been permitted as an additional transfer method for Modbus protocol, which has been around since 1979. Today, Modbus/TCP is an open internet draft standard that Schneider Automation has introduced to the IETF (Internet Engineering Task Force), the organization responsible for Internet standardization. The Modbus services and the object model that have been preserved since the original have been kept unchanged for use with TCP/IP as the transfer medium.

Thus, a new member has been added to the Modbus family, which now consists of the classic Modbus RTU (asynchronous transfer via RS232 or RS485), Modbus Plus (high speed communication via a token passing network) and Modbus/TCP (Ethernet TCP/IP based client-server communication). All the variations share a common application protocol, which defines a universal object model for automation data and communication services for access.

The BC0087 bus controller makes it possible to connect X2X Link I/O nodes to Modbus/TCP. The bus controller is operated with the Modbus/TCP library or by external systems with a Modbus/TCP master function.

- Fieldbus: Modbus/TCP
- I/O configuration via the fieldbus
- DHCP capable
- Integrated 2x switch for efficient cabling
- Configurable I/O cycle (0.5 - 4 ms)
- Response time: 1 - 8 ms (depending on the load on the integrated switch)



<b>Short description</b>	<b>X20BC0087</b>
Bus controller	Modbus/TCP
<b>Fieldbus</b>	<b>X20BC0087</b>
Type	Ethernet
Design	Internal 2x switch, 2x shielded RJ45 port
Cable length	Max. 100 m between two stations (segment length)
Transfer rate	100 MBit/s, auto-negotiation (automatic recognition of full-duplex/half-duplex), Auto-MDI/MDIX
<b>General information</b>	<b>X20BC0087</b>
Status indicators	Module status, bus function
Diagnostics	
Module status	Yes, with status LED and software status
Bus function	Yes, with status LED and software status
Electrical isolation	
Fieldbus - X2X bus	Yes
Fieldbus - I/O	Yes
Power consumption of the bus	2.0 W
Certification	CE, C-UL-US, GOST-R

**Modbus-IDA**  
the architecture for distributed automation

<b>Operational conditions</b>	<b>X20BC0087</b>
Operating temperature	
Horizontal installation	0°C to +55°C
Vertical installation	0°C to +50°C
Relative humidity	5 to 95%, non-condensing
Mounting orientation	Horizontal or vertical
Installation at altitudes above sea level	
0 - 2000 m	No derating
>2000 m	Reduction of ambient temperature by 0.5°C per 100 m
Protection type	IP20
<b>Storage and transport conditions</b>	<b>X20BC0087</b>
Temperature	-25°C to +70°C
Relative humidity	5 to 95%, non-condensing
<b>Mechanical characteristics</b>	<b>X20BC0087</b>
Grid size <sup>1)</sup>	37.5 <sup>+0.2</sup> mm
Comment	Order terminal block 1x X20TB12 separately Order supply module 1x X20PS9400 or X20PS9402 separately Order 1x X20BB80 bus base separately

1) The spacing is based on the width of the X20BB80 bus base. An X20PS9400 or X20PS9402 supply module is also always required for the bus controller.

**Note:** Only the default function model is supported (see respective module description) when the bus controller automatically configures multi-function modules. All other function models are supported when configured accordingly (see BC0087 User's Manual).

Required accessories		
X20TB12	X20 terminal block, 12-pin, 24 V coded	▣ 94
X20PS9400	X20 supply module for bus controller and internal I/O supply, X2X link bus supply	▣ 172
X20PS9402	X20 supply module for bus controller and internal I/O supply, X2X link bus supply, Supply not electrically isolated	▣ 174
X20BB80	X20 bus base, for X20 base module (BC, HB, etc.) and X20 supply module, X20 end plates (left and right) X20AC0SL1/X20AC0SR1 included	▣ 170

## Bus controller EtherNet/IP BC0088



The structure of the X20 bus controller is described on page 155. In addition to the structure, other general information is also provided.

EtherNet/IP is a fieldbus based on Ethernet. EtherNet/IP was developed by Allen-Bradley (part of Rockwell Automation) and later transferred to the Open DeviceNet Vendor Association (ODVA) as open standard. In 1998 a ControlNet International working group designed a procedure to set the already released application protocol, Common Industrial Protocol, to Ethernet. EtherNet/IP was released in March 2000 as open industry standard based on this procedure.

The BC0088 bus controller makes it possible to connect X2X Link I/O nodes to EtherNet/IP. The bus controller is operated via the corresponding X20 interface module or with external systems that have an EtherNet/IP scanner function.

- Fieldbus: EtherNet/IP
- Integrated 3-port switch for efficient cabling
- Auto configuration of the I/O modules
- Can be configured by the scanner (master) using configuration assembly
- DHCP capable
- Configurable I/O cycle (0.5 - 4 ms)
- Minimum fieldbus cycle time (also Request Packet Interval or RPI): 1 ms



<b>Short description</b>	<b>X20BC0088</b>
Bus controller	EtherNet/IP
<b>Fieldbus</b>	<b>X20BC0088</b>
Type	Ethernet
Design	Internal 2-port hardware switch, 2x shielded RJ45 port
Cable length	Max. 100 m between two stations (segment length)
Transfer rate	10/100 MBit/s
	Full-duplex / half-duplex
	Auto negotiation
	Auto-MDI/MDIX
<b>General information</b>	<b>X20BC0088</b>
Status indicators	Module status, network status, bus function
Diagnostics	
Module status	Yes, with status LED and software status
Network status	Yes, with status LED and software status
Bus function	Yes, with status LED and software status
Electrical isolation	
Fieldbus - X2X bus	Yes
Fieldbus - I/O	Yes
Power consumption of the bus	2.0 W
Certification	CE, C-UL-US, GOST-R



<b>Operational conditions</b>	<b>X20BC0088</b>
Operating temperature	
Horizontal installation	0°C to +55°C
Vertical installation	0°C to +50°C
Relative humidity	5 to 95%, non-condensing
Mounting orientation	Horizontal or vertical
Installation at altitudes above sea level	
0 - 2000 m	No derating
>2000 m	Reduction of ambient temperature by 0.5°C per 100 m
Protection type	IP20
<b>Storage and transport conditions</b>	<b>X20BC0088</b>
Temperature	-25°C to +70°C
Relative humidity	5 to 95%, non-condensing
<b>Mechanical characteristics</b>	<b>X20BC0088</b>
Grid size <sup>1)</sup>	37.5 <sup>+0.2</sup> mm
Comment	Order terminal block 1x X20TB12 separately Order supply module 1x X20PS9400 or X20PS9402 separately Order 1x X20BB80 bus base separately

1) The spacing is based on the width of the X20BB80 bus base. An X20PS9400 or X20PS9402 supply module is also always required for the bus controller.

**Note:** Only the default function model is supported (see respective module description) when the bus controller automatically configures multi-function modules. Configuration assemblies can be created by using the B&R FieldbusDESIGNER. All other function models are supported when using a configuration assembly.

Required accessories		
X20TB12	X20 terminal block, 12-pin, 24 V coded	▣ 94
X20PS9400	X20 supply module for bus controller and internal I/O supply, X2X link bus supply	▣ 172
X20PS9402	X20 supply module for bus controller and internal I/O supply, X2X link bus supply, Supply not electrically isolated	▣ 174
X20BB80	X20 bus base, for X20 base module (BC, HB, etc.) and X20 supply module, X20 end plates (left and right) X20AC0SL1/X20AC0SR1 included	▣ 170

# Bus module BB80



The following expansion modules are used on the BB80 bus module:

- X20 base module (BC, HB, etc.)
- X20 supply module

The left and right locking plates are included in the delivery.

- X20 bus base

<b>Short description</b>	<b>X20BB80</b>
Bus module	Bus base - backplane for bus controller fieldbus interface and bus controller supply module
<b>General information</b>	<b>X20BB80</b>
Power consumption	
Bus	-
I/O internal	-
Certification	CE, C-UL-US, GOST-R
<b>Operational conditions</b>	<b>X20BB80</b>
Operating temperature	
Horizontal installation	0°C to +55°C
Vertical installation	0°C to +50°C
Relative humidity	5 to 95%, non-condensing
Mounting orientation	Horizontal or vertical
Installation at altitudes above sea level	
0 - 2000 m	No derating
>2000 m	Reduction of ambient temperature by 0.5°C per 100 m
Protection type	IP20
<b>Storage and transport conditions</b>	<b>X20BB80</b>
Temperature	-25°C to +70°C
Relative humidity	5 to 95%, non-condensing
<b>Mechanical characteristics</b>	<b>X20BB80</b>
Spacing	37.5 <sup>+0.2</sup> mm
Comment	Left and right X20 end plates included in delivery

## Potential control

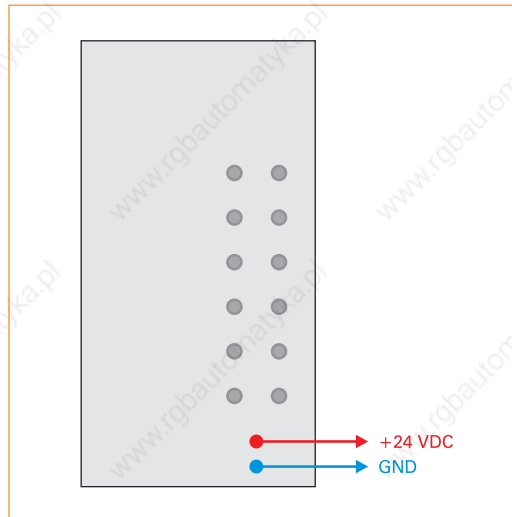



## Supply module PS9400



- Supply for the bus controller, X2X Link, and internal I/O supply
- Feed and bus controller / X2X Link supply electrically isolated
- Redundancy of bus controller / X2X Link supply possible by operating multiple supply modules simultaneously

<b>Short description</b>	<b>X20PS9400</b>
Power supply module	24 VDC supply module for bus controller, X2X Link bus supply and I/O
<b>Bus controller / X2X Link supply input</b>	<b>X20PS9400</b>
Input voltage	24 VDC (-15% / +20%)
Input current	Max. 0.7 A
Reverse polarity protection	Yes
Fuse	Integrated, cannot be exchanged
<b>Bus controller / X2X Link supply output</b>	<b>X20PS9400</b>
Rated output power	7.0 W
Parallel operation	Yes <sup>1)</sup>
Redundant operation of bus controller / X2X Link supply	Yes
<small>1) In parallel operation, only 75% of the rated power can be assumed. Please ensure that all parallel operating power supplies are switched on and off simultaneously.</small>	
<b>Input I/O supply</b>	<b>X20PS9400</b>
Input voltage	24 VDC (-15% / +20%)
Fuse	Recommended pre-fusing max. 10 A slow-blow
<b>Output I/O supply</b>	<b>X20PS9400</b>
Rated output voltage	24 VDC
Permitted contact load	10.0 A
<b>General information</b>	<b>X20PS9400</b>
Status indicators	Overload, operating status, module status
Diagnostics	
Module run/error	Yes, with status LED and software status
Overload	Yes, with status LED and software status
Electrical isolation	
Bus controller / X2X bus supply	Yes
I/O supply	No
Power consumption <sup>1)</sup>	
Bus	1.42 W
I/O internal	0.6 W
Certification	CE, C-UL-US, GOST-R
<small>1) The specified values are maximum values. The exact calculation is available for download as a data sheet with the other module documentation on the B&amp;R homepage.</small>	
<b>Operational conditions</b>	<b>X20PS9400</b>
Operating temperature	
Horizontal installation	0°C to +55°C
Vertical installation	0°C to +50°C
Relative humidity	5 to 95%, non-condensing
Mounting orientation	Horizontal or vertical
Installation at altitudes above sea level	
0 - 2000 m	No derating
>2000 m	Reduction of ambient temperature by 0.5°C per 100 m
Protection type	IP20
<b>Storage and transport conditions</b>	<b>X20PS9400</b>
Temperature	-25°C to +70°C
Relative humidity	5 to 95%, non-condensing
<b>Mechanical characteristics</b>	<b>X20PS9400</b>
Spacing	12.5 <sup>+0.2</sup> mm
Comment	Order terminal block 1x X20TB12 separately Order 1x X20BB8x bus base separately

## Pin assignments

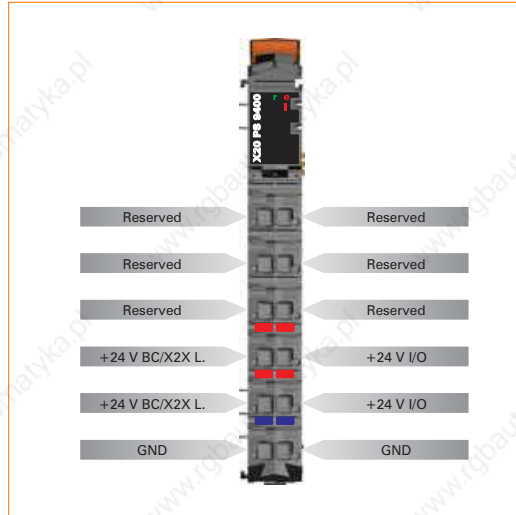

## Connection example

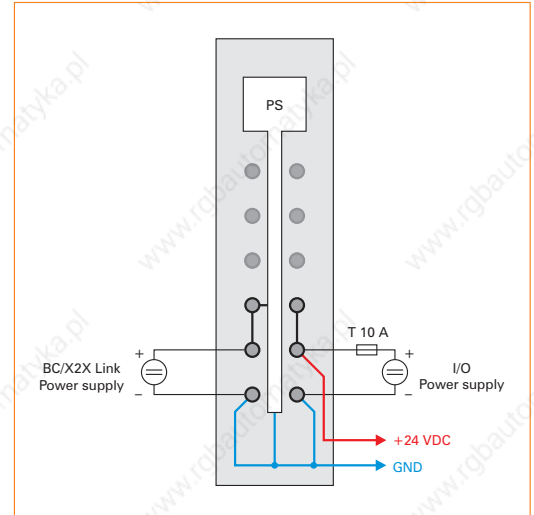

### Required accessories

X20TB12	X20 terminal block, 12-pin, 24 V coded	94
X20BB80	X20 bus base, for X20 base module (BC, HB, etc.) and X20 supply module, X20 end plates (left and right) X20AC0SL1/X20AC0SR1 included	170
X20BB81	X20 bus base with 1 expansion slot, for X20 base module (BC, HB, etc.) and one X20 auxiliary module (IF, HB, etc.) and X20 supply module, X20 end plates (left and right), X20AC0SL1/X20AC0SR1 included	184
X20BB82	X20 bus base with 2 expansion slots, for X20 base module (BC, HB, etc.) and two X20 auxiliary modules (IF, HB, etc.) and X20 supply module, X20 end plates (left and right), X20AC0SL1/X20AC0SR1 included	185

## Supply module PS9402



The supply module PS9402 is used together with an X20 bus controller. It is equipped with a feed for the bus controller, the X2X Link, and the internal I/O supply.

The module is intended as a low-cost supply module for small X20 systems. Potential groups are able to be formed. An expansion or redundancy of the X2X Link with the PS3300 or PS3310 supply module is not possible. Expansion of the X20 system with a bus transmitter is not allowed either.

- Supply for the bus controller, X2X Link, and internal I/O supply
- Low-cost supply module for small X20 systems
- Feed and bus controller / X2X Link supply not electrically isolated
- Expansion or redundancy of bus controller / X2X Link supply not possible by operating multiple supply modules simultaneously

<b>Short description</b>	<b>X20PS9402</b>
Power supply module	24 VDC supply module for bus controller, X2X Link bus supply and I/O
<b>Bus controller / X2X Link supply input</b>	<b>X20PS9402</b>
Input voltage	24 VDC (-15% / +20%)
Input current	Max. 0.7 A
Reverse polarity protection	Yes
Fuse	Integrated, cannot be exchanged
<b>Bus controller / X2X Link supply output</b>	<b>X20PS9402</b>
Rated output power	
Horizontal installation	7.0 W at 45°C and 5.0 W at 55°C
Vertical installation	7.0 W at 40°C and 5.0 W at 50°C
Parallel operation	No
Redundant operation of bus controller / X2X Link supply	No
<b>Input I/O supply</b>	<b>X20PS9402</b>
Input voltage	24 VDC (-15% / +20%)
Fuse	Recommended pre-fusing max. 10 A slow-blow
<b>Output I/O supply</b>	<b>X20PS9402</b>
Rated output voltage	24 VDC
Permitted contact load	10.0 A
<b>General information</b>	<b>X20PS9402</b>
Status indicators	Operating status, module status
Diagnostics	
Module run/error	Yes, with status LED and software status
Overload	Yes, with status LED and software status
Electrical isolation	
Bus controller / X2X bus supply	No
I/O supply	No
Power consumption <sup>1)</sup>	
Bus	1.44 W
I/O internal	0.6 W
Certification	CE, C-UL-US (in development), GOST-R
<small>1) The specified values are maximum values. The exact calculation is also available for download as a data sheet with the other module documentation on the B&amp;R homepage.</small>	
<b>Operational conditions</b>	<b>X20PS9402</b>
Operating temperature	
Horizontal installation	0°C to +55°C
Vertical installation	0°C to +50°C
Relative humidity	5 to 95%, non-condensing
Mounting orientation	Horizontal or vertical
Installation at altitudes above sea level	
0 - 2000 m	No derating
>2000 m	Reduction of ambient temperature by 0.5°C per 100 m
Protection type	IP20
<b>Storage and transport conditions</b>	<b>X20PS9402</b>
Temperature	-25°C to +70°C
Relative humidity	5 to 95%, non-condensing
<b>Mechanical characteristics</b>	<b>X20PS9402</b>
Spacing	12.5 <sup>+0.2</sup> mm
Comment	Order terminal block 1x X20TB12 separately Order 1x X20BB8x bus base separately

### Pin assignments

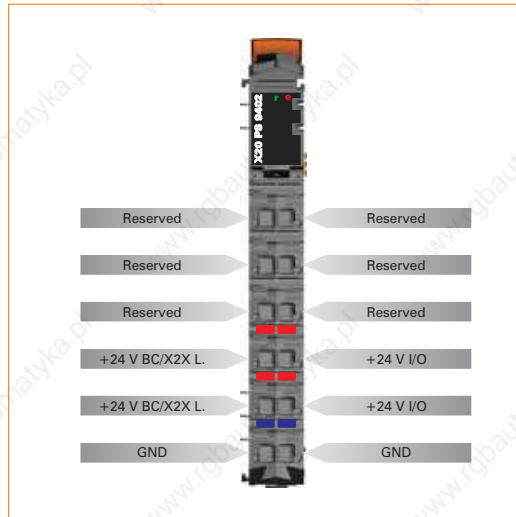

### Connection example

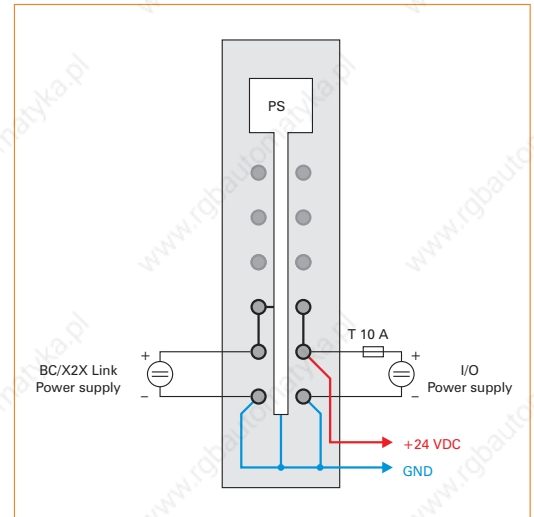

#### Required accessories

X20TB12	X20 terminal block, 12-pin, 24 V coded	▮ 94
X20BB80	X20 bus base, for X20 base module (BC, HB, etc.) and X20 supply module, X20 end plates (left and right) X20AC0SL1/X20AC0SR1 included	▮ 170
X20BB81	X20 bus base with 1 expansion slot, for X20 base module (BC, HB, etc.) and one X20 auxiliary module (IF, HB, etc.) and X20 supply module, X20 end plates (left and right), X20AC0SL1/X20AC0SR1 included	▮ 184

## Expandable bus controllers

### Expandable bus controllers

The expandable bus controller is based on the POWERLINK bus controller BC0083. The expanded bus modules allow up to two interface or hub expansion modules to be mounted depending on the bus controller.

Despite the sleek profile of only 62.5 mm and 87.5 mm, the bus controller feed, the X2X Link bus supply, and the I/O module feed are integrated in the bus controller. No additional power modules are necessary.





## Expandable bus controllers BC1083



The structure of the expandable bus controller is described on page 176. In addition to the structure, other general information is also provided.

The BC1083 bus controller makes it possible to connect X2X Link I/O nodes to POWERLINK V1/V2. It is also possible to operate the X2X Link cycle synchronously 1:1 or synchronous to POWERLINK using a prescaler.

POWERLINK is a standard protocol for Fast Ethernet with true real-time properties. The Ethernet POWERLINK Standardization Group (EPSG, [www.ethernet-powerlink.org](http://www.ethernet-powerlink.org)) ensures that the standard remains open and is continually developed.

- POWERLINK V1/V2
- I/O configuration and firmware update via the fieldbus
- Integrated hub for efficient cabling
- Up to two slots for interface modules



<b>Short description</b>	<b>X20BC1083</b>
Bus controller	POWERLINK V1/V2 Controlled Node with up to two slots for interface modules
<b>Fieldbus</b>	<b>X20BC1083</b>
Type	POWERLINK V1/V2 100 Base-T (ANSI/IEE 802.3)
Design	Internal 2x hub, 2x shielded RJ45 port
Cable length	Max. 100 m between two stations (segment length)
Transfer rate	100 MBit/s
<b>General information</b>	<b>X20BC1083</b>
Status indicators	Module status, bus function
Diagnostics	
Module status	Yes, with status LED and software status
Bus function	Yes, with status LED and software status
Electrical isolation	
Fieldbus - X2X bus	Yes
Fieldbus - I/O	Yes
Power consumption of the bus	2.0 W
Certification	CE, C-UL-US, GOST-R

ETHERNET   
**POWERLINK**

<b>Operational conditions</b>	<b>X20BC1083</b>
Operating temperature	
Horizontal installation	0°C to +55°C
Vertical installation	0°C to +50°C
Relative humidity	5 to 95%, non-condensing
Mounting orientation	Horizontal or vertical
Installation at altitudes above sea level	
0 - 2000 m	No derating
>2000 m	Reduction of ambient temperature by 0.5°C per 100 m
Protection type	IP20
<b>Storage and transport conditions</b>	<b>X20BC1083</b>
Temperature	-25°C to +70°C
Relative humidity	5 to 95%, non-condensing
<b>Mechanical characteristics</b>	<b>X20BC1083</b>
Grid size <sup>1)</sup>	
X20BB81	62.5 <sup>+0.2</sup> mm
X20BB82	87.5 <sup>+0.2</sup> mm
Comment	Order terminal block 1x X20TB12 separately Order supply module 1x X20PS9400 or X20PS9402 separately Order 1x X20BB81 or X20BB82 bus base separately

1) The spacing is based on the width of the X20BB81 or X20BB82 bus base. Up to two interfaces modules and one X20PS9400 or X20PS9402 supply module are also always required for the bus controller.

Required accessories		
X20TB12	X20 terminal block, 12-pin, 24 V coded	▣ 94
X20PS9400	X20 supply module for bus controller and internal I/O supply, X2X link bus supply	▣ 172
X20PS9402	X20 supply module for bus controller and internal I/O supply, X2X link bus supply, Supply not electrically isolated	▣ 174
X20BB81	X20 bus base with 1 expansion slot, for X20 base module (BC, HB, etc.) and one X20 auxiliary module (IF, HB, etc.) and X20 supply module, X20 end plates (left and right), X20AC0SL1/X20AC0SR1 included	▣ 184
X20BB82	X20 bus base with 2 expansion slots, for X20 base module (BC, HB, etc.) and two X20 auxiliary modules (IF, HB, etc.) and X20 supply module, X20 end plates (left and right), X20AC0SL1/X20AC0SR1 included	▣ 185
Optional accessories		
X20IF1091-1	X20 interface module for expandable bus controller, 1 X2X Link master interface, electrically isolated, order 1x TB704 terminal block separately.	▣ 186

## Expandable bus controllers BC8083



The structure of the expandable bus controller is described on page 176. In addition to the structure, other general information is also provided.

The BC8083 bus controller makes it possible to connect X2X Link I/O nodes to POWERLINK V1 and V2. It is also possible to operate the X2X Link cycle synchronously 1:1 or synchronous to POWERLINK using a prescaler.

POWERLINK is a standard protocol for Fast Ethernet with true real-time properties. The Ethernet POWERLINK Standardization Group (EPSP, [www.ethernet-powerlink.org](http://www.ethernet-powerlink.org)) ensures that the standard remains open and is continually developed.

The expanded bus modules allow up to two hub expansion modules to be mounted next to the bus controller. Each expansion module is equipped with two RJ45 connections. Together with the main device, this means that up to six hub ports are available.

- POWERLINK V1/V2
- I/O configuration and firmware update via the fieldbus
- Integrated hub for efficient cabling
- Up to two slots for hub expansion modules
- 2/4/6x Fast Ethernet Hub



<b>Short description</b>	<b>X20BC8083</b>
Bus controller	POWERLINK V1/V2 Controlled Node with up to two slots for hub expansion modules
<b>Fieldbus</b>	<b>X20BC8083</b>
Type	POWERLINK V1/V2 100 Base-T (ANSI/IEE 802.3)
Design	Internal 2x hub, 2x shielded RJ45 port
Cable length	Max. 100 m between two stations (segment length)
Transfer rate	100 MBit/s
<b>General information</b>	<b>X20BC8083</b>
Status indicators	Module status, bus function
Diagnostics	
Module status	Yes, with status LED and software status
Bus function	Yes, with status LED and software status
Electrical isolation	
Fieldbus - X2X bus	Yes
Fieldbus - I/O	Yes
Power consumption of the bus	2.0 W
Certification	CE, C-UL-US (in development), GOST-R

ETHERNET   
**POWERLINK**

<b>Operational conditions</b>	<b>X20BC8083</b>
Operating temperature	
Horizontal installation	0°C to +55°C
Vertical installation	0°C to +50°C
Relative humidity	5 to 95%, non-condensing
Mounting orientation	Horizontal or vertical
Installation at altitudes above sea level	
0 - 2000 m	No derating
>2000 m	Reduction of ambient temperature by 0.5°C per 100 m
Protection type	IP20
<b>Storage and transport conditions</b>	<b>X20BC8083</b>
Temperature	-25°C to +70°C
Relative humidity	5 to 95%, non-condensing
<b>Mechanical characteristics</b>	<b>X20BC8083</b>
Grid size <sup>1)</sup>	
X20BB80	37.5 <sup>+0.2</sup> mm
X20BB81	62.5 <sup>+0.2</sup> mm
X20BB82	87.5 <sup>+0.2</sup> mm
Comment	Order terminal block 1x X20TB12 separately Order supply module 1x X20PS9400 or X20PS9402 separately Order 1x X20BB8x bus base separately

1) The spacing is based on the width of the X20BB8x bus base. Up to two X20HB2880 hub expansion modules and one X20PS9400 or X20PS9402 supply module are also always required for the bus controller.

<b>Required accessories</b>		
X20TB12	X20 terminal block, 12-pin, 24 V coded	▣ 94
X20PS9400	X20 supply module for bus controller and internal I/O supply, X2X link bus supply	▣ 172
X20PS9402	X20 supply module for bus controller and internal I/O supply, X2X link bus supply, Supply not electrically isolated	▣ 174
X20BB80	X20 bus base, for X20 base module (BC, HB, etc.) and X20 supply module, X20 end plates (left and right) X20AC0SL1/X20AC0SR1 included	▣ 170
X20BB81	X20 bus base with 1 expansion slot, for X20 base module (BC, HB, etc.) and one X20 auxiliary module (IF, HB, etc.) and X20 supply module, X20 end plates (left and right), X20AC0SL1/X20AC0SR1 included	▣ 184
X20BB82	X20 bus base with 2 expansion slots, for X20 base module (BC, HB, etc.) and two X20 auxiliary modules (IF, HB, etc.) and X20 supply module, X20 end plates (left and right), X20AC0SL1/X20AC0SR1 included	▣ 185
<b>Optional accessories</b>		
X20HB2880	X20 hub expansion module, integrated 2x hub, status indicator LEDs, 2x RJ45 connection	▣ 187

## Expandable bus controllers BC8084



The structure of the expandable bus controller is described on page 176. In addition to the structure, other general information is also provided.

The BC8084 bus controller makes it possible to connect X2X Link I/O nodes to POWERLINK V1 and V2. It is also possible to operate the X2X Link cycle synchronously 1:1 or synchronously to POWERLINK using a prescaler.

POWERLINK is a standard protocol for Fast Ethernet with true real-time properties. The Ethernet POWERLINK Standardization Group (EPSP, [www.ethernet-powerlink.org](http://www.ethernet-powerlink.org)) ensures that the standard remains open and is continually developed.

Using POWERLINK, systems with redundant cabling can be implemented. Unlike ring redundancy, cable looping, which can sometimes be problematic, is not required for cable redundancy. This allows the creation of all types of tree structures. When using a device with the link selector function, data is always transferred via the highest quality network lines. The Link Selector function is integrated in the BC8084 bus controller (see section "POWERLINK cable redundancy section", on page 57 and "X20 redundancy system", on page 57).

- POWERLINK V1/V2
- I/O configuration and firmware update via the fieldbus
- Integrated compact link selector function
- Two active hub expansion modules can be connected to the bus controller
- Redundant supply possible



<b>Short description</b>	<b>X20BC8084</b>
Bus controller	POWERLINK V1/V2 Controlled Node with Compact Link Selector
<b>Fieldbus</b>	<b>X20BC8084</b>
Type	POWERLINK V1/V2 100 Base-T (ANSI/IEE 802.3)
Design	Internal 2x hub, 2x shielded RJ45 port
Cable length	Max. 100 m between two stations (segment length)
Transfer rate	100 MBit/s
<b>General information</b>	<b>X20BC8084</b>
Status indicators	Module status, bus function
Diagnostics	
Module status	Yes, with status LED and software status
Bus function	Yes, with status LED and software status
Electrical isolation	
Fieldbus - X2X bus	Yes
Fieldbus - I/O	Yes
Power consumption of the bus	2.0 W
Certification	CE, C-UL-US (in development), GOST-R

ETHERNET   
**POWERLINK**

<b>Operational conditions</b>	<b>X20BC8084</b>
Operating temperature	
Horizontal installation	0°C to +55°C
Vertical installation	0°C to +50°C
Relative humidity	5 to 95%, non-condensing
Mounting orientation	Horizontal or vertical
Installation at altitudes above sea level	
0 - 2000 m	No derating
>2000 m	Reduction of ambient temperature by 0.5°C per 100 m
Protection type	IP20
<b>Storage and transport conditions</b>	<b>X20BC8084</b>
Temperature	-25°C to +70°C
Relative humidity	5 to 95%, non-condensing
<b>Mechanical characteristics</b>	<b>X20BC8084</b>
Grid size <sup>1)</sup>	
X20BB81	62.5 <sup>+0.2</sup> mm
X20BB82	87.5 <sup>+0.2</sup> mm
Comment	Order terminal block 1x X20TB12 separately Order supply module 1x X20PS9400 or X20PS9402 separately Order 1x X20BB81 or X20BB82 bus base separately

1) The spacing is based on the width of the X20BB81 or X20BB82 bus base. Up to two X20HB2885 hub expansion modules and one X20PS9400 or X20PS9402 supply module are also always required for the bus controller.

<b>Required accessories</b>		
X20TB12	X20 terminal block, 12-pin, 24 V coded	94
X20PS9400	X20 supply module for bus controller and internal I/O supply, X2X link bus supply	172
X20PS9402	X20 supply module for bus controller and internal I/O supply, X2X link bus supply, Supply not electrically isolated	174
X20BB80	X20 bus base, for X20 base module (BC, HB, etc.) and X20 supply module, X20 end plates (left and right) X20AC0SL1/X20AC0SR1 included	170
X20BB82	X20 bus base with 2 expansion slots, for X20 base module (BC, HB, etc.) and two X20 auxiliary modules (IF, HB, etc.) and X20 supply module, X20 end plates (left and right), X20AC0SL1/X20AC0SR1 included	185
<b>Optional accessories</b>		
X20HB2885	X20 hub expansion module, integrated active 2x hub, status indicator LEDs, 2x RJ45 connection	188

# Bus module BB81



The BB81 bus module has an expansion slot. The following expansion modules are used on the module:

- X20 base module (BC, HB, etc.)
- X20 add-on module (IF, HB, etc.)
- X20 supply module

The left and right locking plates are included in the delivery.

- X20 bus base with one expansion slot

<b>Short description</b>	<b>X20BB81</b>
Bus module	X20 bus base with one expansion slot
<b>General information</b>	<b>X20BB81</b>
Power consumption	
Bus	-
I/O internal	-
Certification	CE, C-UL-US, GOST-R
<b>Operational conditions</b>	<b>X20BB81</b>
Operating temperature	
Horizontal installation	0°C to +55°C
Vertical installation	0°C to +50°C
Relative humidity	5 to 95%, non-condensing
Mounting orientation	Horizontal or vertical
Installation at altitudes above sea level	
0 - 2000 m	No derating
>2000 m	Reduction of ambient temperature by 0.5°C per 100 m
Protection type	IP20
<b>Storage and transport conditions</b>	<b>X20BB81</b>
Temperature	-25°C to +70°C
Relative humidity	5 to 95%, non-condensing
<b>Mechanical characteristics</b>	<b>X20BB81</b>
Spacing	62.5 <sup>+0.2</sup> mm
Comment	Left and right X20 end plates included in delivery

## Potential control

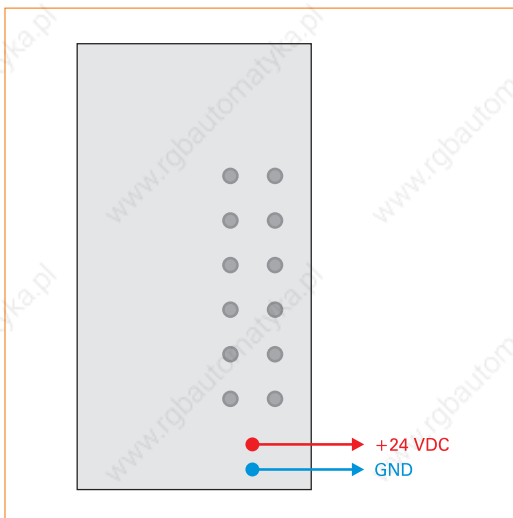

# Bus module BB82



The BB82 bus module has two expansion slots. The following expansion modules are used on the module:

- X20 base module (BC, HB, etc.)
- Two X20 add-on module (IF, HB, etc.)
- X20 supply module

The left and right locking plates are included in the delivery.

- X20 bus base with two expansion slots

<b>Short description</b>	<b>X20BB82</b>
Bus module	Bus base with two expansion slots
<b>General information</b>	<b>X20BB82</b>
Power consumption	
Bus	-
I/O internal	-
Certification	CE, C-UL-US (in development), GOST-R
<b>Operational conditions</b>	<b>X20BB82</b>
Operating temperature	
Horizontal installation	0°C to +55°C
Vertical installation	0°C to +50°C
Relative humidity	5 to 95%, non-condensing
Mounting orientation	Horizontal or vertical
Installation at altitudes above sea level	
0 - 2000 m	No derating
>2000 m	Reduction of ambient temperature by 0.5°C per 100 m
Protection type	IP20
<b>Storage and transport conditions</b>	<b>X20BB82</b>
Temperature	-25°C to +70°C
Relative humidity	5 to 95%, non-condensing
<b>Mechanical characteristics</b>	<b>X20BB82</b>
Spacing	87.5 <sup>+0.2</sup> mm
Comment	Left and right X20 end plates included in delivery

## Potential control

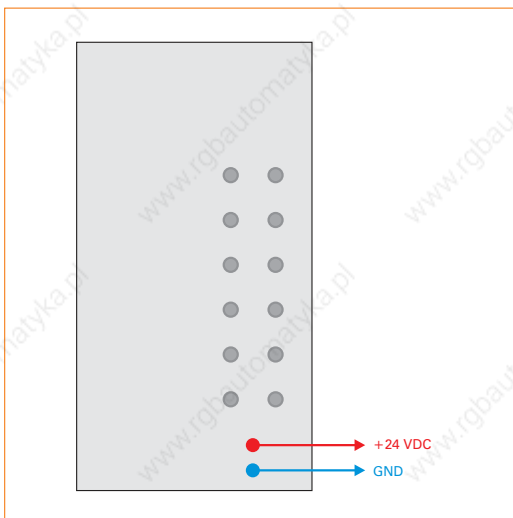

## Interface module IF1091-1



The IF1091-1 interface module is operated in the BC1083 expandable bus controller. It is equipped with an X2X Link master interface.

- X2X Link Connection

<b>Short description</b>	<b>X20IF1091-1</b>
Communication module	1x X2X Link master
<b>Interfaces</b>	<b>X20IF1091-1</b>
<b>Interface IF1</b>	
Type	X2X Link master
Design	4-pin multipoint connector
<b>General information</b>	<b>X20IF1091-1</b>
Status indicators	Module status, data transfer
<b>Diagnostics</b>	
Module status	Yes, with status LED
Data transfer	Yes, with status LED
<b>Electrical isolation</b>	
PLC - IF1	Yes
Power consumption	1.29 W
Certification	CE, C-UL-US (in development), GOST-R
<b>Operational conditions</b>	<b>X20IF1091-1</b>
<b>Operating temperature</b>	
Horizontal installation	0°C to +55°C
Vertical installation	0°C to +50°C
Relative humidity	5 to 95%, non-condensing
Mounting orientation	Horizontal or vertical
<b>Installation at altitudes above sea level</b>	
0 - 2000 m	No derating
>2000 m	Reduction of ambient temperature by 0.5°C per 100 m
Protection type	IP20
<b>Storage and transport conditions</b>	<b>X20IF1091-1</b>
Temperature	-25°C to +70°C
Relative humidity	5 to 95%, non-condensing
<b>Mechanical characteristics</b>	<b>X20IF1091-1</b>
Slot	In expandable bus controllers
Comment	Order 1x TB704 terminal block separately

<b>Required accessories</b>		
0TB704.9	Accessory terminal block, 4-pin, screw clamp, 1.5 mm <sup>2</sup>	680
0TB704.91	Accessory terminal block, 4-pin, cage clamp, 2.5 mm <sup>2</sup>	680

## Hub expansion module HB2880



The BC8083 POWERLINK bus controller and the HB8880 stand alone hub are equipped with a modular hub expansion. Depending on the bus base used, one or two additional slots are available. The HB2880 hub expansion module can be operated in these slots.

The HB2880 hub expansion module is equipped with an integrated 2x hub. The Ethernet connections are made using RJ45 connectors. The module and network status is indicated using LEDs.

- Hub expansion module
- 2x Fast Ethernet hub

<b>Short description</b>	<b>X20HB2880</b>
Hub	2x Fast Ethernet hub for hub expansion
<b>Interfaces</b>	<b>X20HB2880</b>
Type	Ethernet
Standard (compliance)	ANSI/IEEE 802.3
Signal	10/100 Base-T
Port design	Shielded RJ45 ports
Transfer rate	10 MBit/s or 100 MBit/s
Cable length	Max. 100 m between two stations (segment length)
1) If devices that use 10 MBit/s as well as 100 MBit/s are connected, then there is no communication between these devices. Devices with 10/100 MBit/s auto-negotiation are always operated with 100 MBit/s on the hub.	
<b>General information</b>	<b>X20HB2880</b>
Status indicators	Module status, bus function
Diagnostics	
Module status	Yes, with status LED
Bus function	Yes, with status LED
Electrical isolation	
Fieldbus supply	Yes
Power consumption	TBD
Certification	CE, C-UL-US (in development), GOST-R
<b>Operational conditions</b>	<b>X20HB2880</b>
Operating temperature	
Horizontal installation	0°C to +55°C
Vertical installation	0°C to +50°C
Relative humidity	5 to 95%, non-condensing
Mounting orientation	Horizontal or vertical
Installation at altitudes above sea level	
0 - 2000 m	No derating
>2000 m	Reduction of ambient temperature by 0.5°C per 100 m
Protection type	IP20
<b>Storage and transport conditions</b>	<b>X20HB2880</b>
Temperature	-25°C to +70°C
Relative humidity	5 to 95%, non-condensing
<b>Mechanical characteristics</b>	<b>X20HB2880</b>
Slot	Hub expansion for BC8083 and HB8880

## Hub expansion module HB2885



The HB2885 hub expansion module can be operated on the BC8084 POWERLINK bus controller and on the HB8884 compact link selector. It is equipped with an integrated 2x hub. The Ethernet connections are made using RJ45 connectors. The module and network status is indicated using LEDs.

- Hub expansion module
- 2x Fast Ethernet hub
- Hot-swap capable

<b>Short description</b>	<b>X20HB2885</b>
Hub	2x Fast Ethernet hub for hub expansion
<b>Interfaces</b>	<b>X20HB2885</b>
Type	Ethernet
Standard (compliance)	ANSI/IEEE 802.3
Signal	10/100 Base-T
Port design	Shielded RJ45 ports
Transfer rate	10 MBit/s or 100 MBit/s
Cable length	Max. 100 m between two stations (segment length)
1) If devices that use 10 MBit/s as well as 100 MBit/s are connected, then there is no communication between these devices. Devices with 10/100 MBit/s auto-negotiation are always operated with 100 MBit/s on the hub.	
<b>General information</b>	<b>X20HB2885</b>
Status indicators	Module status, bus function
Diagnostics	
Module status	Yes, with status LED
Bus function	Yes, with status LED
Electrical isolation	
Fieldbus supply	Yes
Power consumption	TBD
Certification	CE, C-UL-US (in development), GOST-R
<b>Operational conditions</b>	<b>X20HB2885</b>
Operating temperature	
Horizontal installation	0°C to +55°C
Vertical installation	0°C to +50°C
Relative humidity	5 to 95%, non-condensing
Mounting orientation	Horizontal or vertical
Installation at altitudes above sea level	
0 - 2000 m	No derating
>2000 m	Reduction of ambient temperature by 0.5°C per 100 m
Protection type	IP20
<b>Storage and transport conditions</b>	<b>X20HB2885</b>
Temperature	-25°C to +70°C
Relative humidity	5 to 95%, non-condensing
<b>Mechanical characteristics</b>	<b>X20HB2885</b>
Slot	Hub expansion for BC8084 and HB8884

# Interface module IF1020



- RS232 interface configurable as online interface

<b>Short description</b>	<b>X20IF1020</b>
Communication module	1x RS232
<b>Interfaces</b>	<b>X20IF1020</b>
<b>Interface IF1</b>	
Type	RS232
Design	9-pin DSUB plug
Maximum transfer rate	115.2 kBit/s
<b>General information</b>	<b>X20IF1020</b>
Status indicators	Module status, data transfer
<b>Diagnostics</b>	
Module status	Yes, with status LED
Data transfer	Yes, with status LED
<b>Electrical isolation</b>	
PLC - IF1	Yes
Power consumption	0.33 W
Certification	CE, C-UL-US, GOST-R
<b>Operational conditions</b>	<b>X20IF1020</b>
<b>Operating temperature</b>	
Horizontal installation	0°C to +55°C
Vertical installation	0°C to +50°C
<b>Relative humidity</b>	
	5 to 95%, non-condensing
<b>Mounting orientation</b>	
	Horizontal or vertical
<b>Installation at altitudes above sea level</b>	
0 - 2000 m	No derating
>2000 m	Reduction of ambient temperature by 0.5°C per 100 m
Protection type	IP20
<b>Storage and transport conditions</b>	<b>X20IF1020</b>
Temperature	-25°C to +70°C
Relative humidity	5 to 95%, non-condensing
<b>Mechanical characteristics</b>	<b>X20IF1020</b>
Slot	In X20 CPU

<b>Optional accessories</b>	
0G0001.00-090	Cable PC <-> PLC/PW, RS232, online cable

## Interface module IF1030



- RS485/RS422 connection

<b>Short description</b>	<b>X20IF1030</b>
Communication module	1x RS485/RS422
<b>Interfaces</b>	<b>X20IF1030</b>
Interface IF1	
Type	RS485/RS422
Design	9-pin DSUB socket
Maximum transfer rate	115.2 kBit/s
<b>General information</b>	<b>X20IF1030</b>
Status indicators	Module status, data transfer
Diagnostics	
Module status	Yes, with status LED
Data transfer	Yes, with status LED
Electrical isolation	
PLC - IF1	Yes
Power consumption	0.4 W
Certification	CE, C-UL-US, GOST-R
<b>Operational conditions</b>	<b>X20IF1030</b>
Operating temperature	
Horizontal installation	0°C to +55°C
Vertical installation	0°C to +50°C
Relative humidity	5 to 95%, non-condensing
Mounting orientation	Horizontal or vertical
Installation at altitudes above sea level	
0 - 2000 m	No derating
>2000 m	Reduction of ambient temperature by 0.5°C per 100 m
Protection type	IP20
<b>Storage and transport conditions</b>	<b>X20IF1030</b>
Temperature	-25°C to +70°C
Relative humidity	5 to 95%, non-condensing
<b>Mechanical characteristics</b>	<b>X20IF1030</b>
Slot	In X20 CPU

<b>Optional accessories</b>	
0G1000.00-090	Bus connector, RS485, for Profibus networks

# Interface module IF1061



- Profibus DP master



<b>Short description</b>	<b>X20IF1061</b>
Communication module	1x Profibus DP master
<b>Interfaces</b>	<b>X20IF1061</b>
Interface IF1	
Fieldbus	Profibus DP master
Type	RS485
Design	9-pin DSUB socket
Maximum transfer rate	12 MBit/s
<b>General information</b>	<b>X20IF1061</b>
Status indicators	Module status, bus status
Diagnostics	
Module status	Yes, with status LED and software status
Bus status	Yes, with status LED and software status
Electrical isolation	
PLC - IF1	Yes
Power consumption	1.4 W
Certification	CE, C-UL-US, GOST-R
<b>Operational conditions</b>	<b>X20IF1061</b>
Operating temperature	
Horizontal installation	0°C to +55°C
Vertical installation	0°C to +50°C
Relative humidity	5 to 95%, non-condensing
Mounting orientation	Horizontal or vertical
Installation at altitudes above sea level	
0 - 2000 m	No derating
>2000 m	Reduction of ambient temperature by 0.5°C per 100 m
Protection type	IP20
<b>Storage and transport conditions</b>	<b>X20IF1061</b>
Temperature	-25°C to +70°C
Relative humidity	5 to 95%, non-condensing
<b>Mechanical characteristics</b>	<b>X20IF1061</b>
Slot	In X20 CPU

<b>Optional accessories</b>	
0G1000.00-090	Bus connector, RS485, for Profibus networks
	690

## Interface module IF1063



- Profibus DP Slave connection



<b>Short description</b>	<b>X20IF1063</b>
Communication module	1x Profibus DP slave
<b>Interfaces</b>	<b>X20IF1063</b>
<b>Interface IF1</b>	
Fieldbus	Profibus DP slave
Type	RS485
Design	9-pin DSUB socket
Maximum transfer rate	12 MBit/s
<b>General information</b>	<b>X20IF1063</b>
Status indicators	Module status, data transfer
<b>Diagnostics</b>	
Module status	Yes, with status LED
Data transfer	Yes, with status LED
<b>Electrical isolation</b>	
PLC - IF1	Yes
Power consumption	0.87 W
Certification	CE, C-UL-US, GOST-R
<b>Operational conditions</b>	<b>X20IF1063</b>
<b>Operating temperature</b>	
Horizontal installation	0°C to +55°C
Vertical installation	0°C to +50°C
Relative humidity	5 to 95%, non-condensing
<b>Mounting orientation</b>	
Installation at altitudes above sea level	Horizontal or vertical
0 - 2000 m	No derating
>2000 m	Reduction of ambient temperature by 0.5°C per 100 m
Protection type	IP20
<b>Storage and transport conditions</b>	<b>X20IF1063</b>
Temperature	-25°C to +70°C
Relative humidity	5 to 95%, non-condensing
<b>Mechanical characteristics</b>	<b>X20IF1063</b>
Slot	In X20 CPU

<b>Optional accessories</b>		
0G1000.00-090	Bus connector, RS485, for Profibus networks	690

## Interface module IF1072



- CAN Bus Connection
- Integrated terminating resistor

**CAN**

<b>Short description</b>		<b>X20IF1072</b>
Communication module		1x CAN bus
<b>Interfaces</b>		<b>X20IF1072</b>
Interface IF1		
Type		CAN bus
Design		5-pin multipoint connector
Maximum transfer rate		1 MBit/s
<b>General information</b>		<b>X20IF1072</b>
Status indicators		Module status, data transfer, terminating resistor
Diagnostics		
Module status		Yes, with status LED
Data transfer		Yes, with status LED
Terminating resistor		Yes, with status LED
Electrical isolation		
PLC - IF1		Yes
Power consumption		0.79 W
Certification		CE, C-UL-US, GOST-R
<b>Operational conditions</b>		<b>X20IF1072</b>
Operating temperature		
Horizontal installation		0°C to +55°C
Vertical installation		0°C to +50°C
Relative humidity		
		5 to 95%, non-condensing
Mounting orientation		
		Horizontal or vertical
Installation at altitudes above sea level		
0 - 2000 m		No derating
>2000 m		Reduction of ambient temperature by 0.5°C per 100 m
Protection type		
		IP20
<b>Storage and transport conditions</b>		<b>X20IF1072</b>
Temperature		-25°C to +70°C
Relative humidity		5 to 95%, non-condensing
<b>Mechanical characteristics</b>		<b>X20IF1072</b>
Slot		In X20 CPU
Comment		Order 1x TB2105 terminal block separately

<b>Required accessories</b>		
0TB2105.9010	Accessory terminal block, 5-pin, screw clamp, 1.5 mm <sup>2</sup>	681
0TB2105.9110	Accessory terminal block, 5-pin, cage clamp, 2.5 mm <sup>2</sup>	681

## Interface module IF1082



- POWERLINK V1/V2 for real-time Ethernet communication
- Integrated hub for efficient cabling
- Configurable ring redundancy

ETHERNET   
**POWERLINK**

<b>Short description</b>	<b>X20IF1082</b>
Communication module	1x POWERLINK V1/V2 managing or controlled node
<b>Interfaces</b>	<b>X20IF1082</b>
Interface IF1	
Fieldbus	POWERLINK V1/V2
Type	100 Base-T (ANSI/IEEE 802.3)
Design	Internal 2x hub, 2x shielded RJ45 port
Transfer rate	100 MBit/s
Cable length	Max. 100 m between two stations (segment length)
<b>General information</b>	<b>X20IF1082</b>
Status indicators	Module status, bus function
Diagnostics	
Module status	Yes, with status LED and software status
Bus function	Yes, with status LED and software status
Electrical isolation	
PLC - IF1	Yes
Power consumption	2.0 W
Certification	CE, C-UL-US, GOST-R
<b>Operational conditions</b>	<b>X20IF1082</b>
Operating temperature	
Horizontal installation	0°C to +55°C
Vertical installation	0°C to +50°C
Relative humidity	5 to 95%, non-condensing
Mounting orientation	Horizontal or vertical
Installation at altitudes above sea level	
0 - 2000 m	No derating
>2000 m	Reduction of ambient temperature by 0.5°C per 100 m
Protection type	IP20
<b>Storage and transport conditions</b>	<b>X20IF1082</b>
Temperature	-25°C to +70°C
Relative humidity	5 to 95%, non-condensing
<b>Mechanical characteristics</b>	<b>X20IF1082</b>
Slot	In X20 CPU

<b>Optional accessories</b>		
X20CA0E61.xxxx	POWERLINK connection cable - RJ45 to RJ45	391
X67CA0E41.xxxx	POWERLINK attachment cable - RJ45 to M12	391

# Interface module IF1091



- X2X Link Connection

<b>Short description</b>		<b>X20IF1091</b>
Communication module		1x X2X Link master
<b>Interfaces</b>		<b>X20IF1091</b>
Interface IF1		
Type		X2X Link master
Design		4-pin multipoint connector
<b>General information</b>		<b>X20IF1091</b>
Status indicators		Module status, data transfer
Diagnostics		
Module status		Yes, with status LED
Data transfer		Yes, with status LED
Electrical isolation		
PLC - IF1		Yes
Power consumption		0.97 W
Certification		CE, C-UL-US, GOST-R
<b>Operational conditions</b>		<b>X20IF1091</b>
Operating temperature		
Horizontal installation		0°C to +55°C
Vertical installation		0°C to +50°C
Relative humidity		5 to 95%, non-condensing
Mounting orientation		Horizontal or vertical
Installation at altitudes above sea level		
0 - 2000 m		No derating
>2000 m		Reduction of ambient temperature by 0.5°C per 100 m
Protection type		IP20
<b>Storage and transport conditions</b>		<b>X20IF1091</b>
Temperature		-25°C to +70°C
Relative humidity		5 to 95%, non-condensing
<b>Mechanical characteristics</b>		<b>X20IF1091</b>
Slot		In X20 CPU
Comment		Order 1x TB704 terminal block separately

<b>Required accessories</b>		
0TB704.9	Accessory terminal block, 4-pin, screw clamp, 1.5 mm <sup>2</sup>	680
0TB704.91	Accessory terminal block, 4-pin, cage clamp, 2.5 mm <sup>2</sup>	680

## Interface module IF2772



- Dual CAN bus connection
- Integrated terminating resistors

# CAN

<b>Short description</b>	<b>X20IF2772</b>
Communication module	2x CAN bus
<b>Interfaces</b>	<b>X20IF2772</b>
Interfaces IF1 and IF2	
Type	CAN bus
Design	2x 5-pin multipoint connector
Maximum transfer rate	1 MBit/s
<b>General information</b>	<b>X20IF2772</b>
Status indicators	Module status, data transfer, terminating resistor
Diagnostics	
Module status	Yes, with status LED
Data transfer	Yes, with status LED
Terminating resistor	Yes, with status LED
Electrical isolation	
PLC - IF1/IF2	Yes
IF1 - IF2	Yes
Power consumption	1.2 W
Certification	CE, C-UL-US, GOST-R
<b>Operational conditions</b>	<b>X20IF2772</b>
Operating temperature	
Horizontal installation	0°C to +55°C
Vertical installation	0°C to +50°C
Relative humidity	5 to 95%, non-condensing
Mounting orientation	
Installation at altitudes above sea level	
0 - 2000 m	No derating
>2000 m	Reduction of ambient temperature by 0.5°C per 100 m
Protection type	IP20
<b>Storage and transport conditions</b>	<b>X20IF2772</b>
Temperature	-25°C to +70°C
Relative humidity	5 to 95%, non-condensing
<b>Mechanical characteristics</b>	<b>X20IF2772</b>
Slot	In X20 CPU
Comment	Order 2x TB718 terminal blocks separately

Required accessories		
0TB2105.9010	Accessory terminal block, 5-pin, screw clamp, 1.5 mm <sup>2</sup>	681
0TB2105.9110	Accessory terminal block, 5-pin, cage clamp, 2.5 mm <sup>2</sup>	681

## Interface module IF2792



- X2X Link connection
- CAN bus connection
- Integrated terminating resistor

# CAN

<b>Short description</b>	<b>X20IF2792</b>
Communication module	1x X2X Link master, 1x CAN bus
<b>Interfaces</b>	<b>X20IF2792</b>
<b>Interface IF1</b>	
Type	X2X Link master
Design	4-pin multipoint connector
<b>Interface IF2</b>	
Type	CAN bus
Design	5-pin multipoint connector
Maximum transfer rate	1 MBit/s
<b>General information</b>	<b>X20IF2792</b>
Status indicators	Module status, data transfer, terminating resistor
<b>Diagnostics</b>	
Module status	Yes, with status LED
Data transfer	Yes, with status LED
Terminating resistor	Yes, with status LED
<b>Electrical isolation</b>	
PLC - IF1/IF2	Yes
IF1 - IF2	Yes
Power consumption	1.51 W
Certification	CE, C-UL-US, GOST-R
<b>Operational conditions</b>	<b>X20IF2792</b>
<b>Operating temperature</b>	
Horizontal installation	0°C to +55°C
Vertical installation	0°C to +50°C
Relative humidity	5 to 95%, non-condensing
<b>Mounting orientation</b>	
Installation at altitudes above sea level	Horizontal or vertical
<b>Installation at altitudes above sea level</b>	
0 - 2000 m	No derating
>2000 m	Reduction of ambient temperature by 0.5°C per 100 m
Protection type	IP20
<b>Storage and transport conditions</b>	<b>X20IF2792</b>
Temperature	-25°C to +70°C
Relative humidity	5 to 95%, non-condensing
<b>Mechanical characteristics</b>	<b>X20IF2792</b>
Slot	In X20 CPU
Comment	Order 1x TB704 and 1x TB2105 terminal blocks separately

<b>Required accessories</b>		
0TB704.9	Accessory terminal block, 4-pin, screw clamp, 1.5 mm <sup>2</sup>	680
0TB704.91	Accessory terminal block, 4-pin, cage clamp, 2.5 mm <sup>2</sup>	680
0TB2105.9010	Accessory terminal block, 5-pin, screw clamp, 1.5 mm <sup>2</sup>	681
0TB2105.9110	Accessory terminal block, 5-pin, cage clamp, 2.5 mm <sup>2</sup>	681

# Interface module CS1011



- X2X SmartWire master for controlling up to 16 SmartWire slaves
- External 24 VDC feed protected against reverse polarity for supplying the slave application (e.g. Moeller xStart protection DILM)

<b>Short description</b>	<b>X20CS1011</b>
Communication module	1 SmartWire master for controlling up to 16 slaves
<b>SmartWire master</b>	<b>X20CS1011</b>
Transfer rate	19200 Bit/s
Data format	1 start bit, 8 data bits, no parity bit, 1 stop bit
Bus level	17 V (recessive), 0 V (dominant)
SWIRE terminal 2	0 V / 5 V (active), CMOS level
SWIRE terminal 6 (17 VDC)	
Section	16.3 VDC to 16.8 VDC
Typical	16.6 VDC
Load	Max. 400 mA for 16 SmartWire slaves
Short circuit protection	Yes
U-Aux (24 VDC aux supply)	
Input voltage	24 VDC (-15% / +20%)
Reverse polarity protection	Yes
Connection	External via terminal block <sup>1)</sup>
Fuse	Recommended pre-fusing max. 3 A slow-blow
SWIRE terminal 1 (24 VDC)	
Section	Supply like feed
Load	Maximum 3 A for supplying 16 SmartWire slave auxiliary
Short circuit protection	No
Bus extension	Maximum 4 m
Configuration button	
Internal	On the front of the X20CS1011 module
External	Connection via terminal block
<sup>1)</sup> Using an external feed makes it possible to shut down via E-stop or switching relay	
<b>General information</b>	<b>X20CS1011</b>
Status indicators	SmartWire bus function, external supply voltage, operating state, module status
Diagnostics	
Module run/error	Yes, with status LED and software status
SmartWire operating state	Yes, with status LED and software status
U Aux	Yes, with status LED
Certification	CE, C-UL-US (in development), GOST-R
Electrical isolation	
SmartWire bus - X2X bus	Yes
SmartWire supply (17 VDC) -	No
Bus supply (24 VDC)	
Power consumption	
Bus	0.01 W
I/O internal	1.0 W
Power output	
I/O internal	6.8 W for supplying external slaves (equal to 16 slaves each with 0.425 W)
<b>Operational conditions</b>	<b>X20CS1011</b>
Operating temperature	
Horizontal installation	0°C to +55°C
Vertical installation	0°C to +50°C
Relative humidity	5 to 95%, non-condensing
Mounting orientation	Horizontal or vertical
Installation at altitudes above sea level	
0 - 2000 m	No derating
>2000 m	Reduction of ambient temperature by 0.5°C per 100 m
Protection type	IP20

<b>Storage and transport conditions</b>	<b>X20CS1011</b>
Temperature	-25°C to +70°C
Relative humidity	5 to 95%, non-condensing
<b>Mechanical characteristics</b>	<b>X20CS1011</b>
Spacing	12.5 <sup>+0.2</sup> mm
Comment	Order SmartWire connection cable X20CA4S00.00xx separately Order bus module 1x X20BM11 separately

### Pin assignments

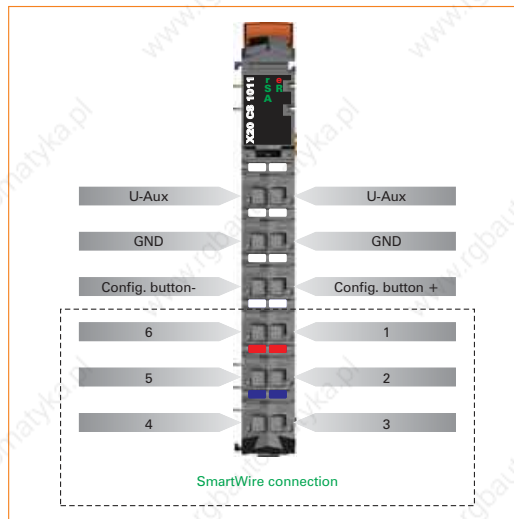

### Connection example

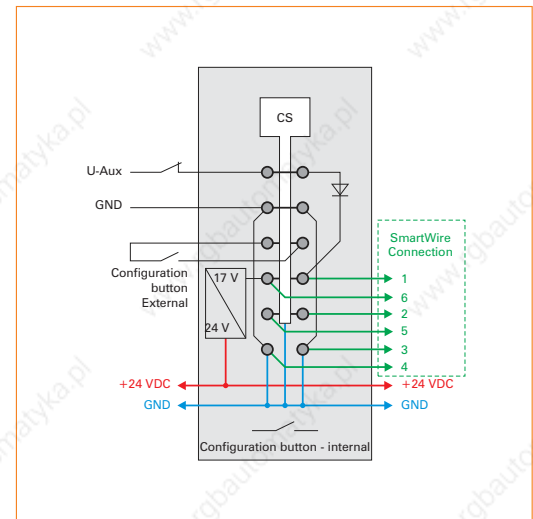

Required accessories	
X20CA4S00.0005	SmartWire connection cable, X20TB12 on SmartWire plug, 0.5 m
X20CA4S00.0015	SmartWire connection cable, X20TB12 on SmartWire plug, 1.5 m
X20BM11	X20 bus module, 24 V coded, internal I/O supply is interconnected

## Interface module CS1020



- RS232 interface for serial, remote connection of complex devices to the X20 System

<b>Short description</b>		<b>X20CS1020</b>
Communication module		1x RS232
<b>Interfaces</b>		<b>X20CS1020</b>
Interface IF1		
Type		RS232
Design		Contact via 12-pin terminal block TB12
Maximum transfer rate		115.2 kBit/s
<b>General information</b>		<b>X20CS1020</b>
Status indicators		Data transfer, operating status, module status
Diagnostics		
Module run/error		Yes, with status LED and software status
Data transfer		Yes, with status LED
Electrical isolation		
IF1 - Bus		Yes
IF1 - I/O supply		No
Power consumption		
Bus		0.01 W
I/O internal		1.44 W
Certification		CE, C-UL-US, GOST-R
<b>Operational conditions</b>		<b>X20CS1020</b>
Operating temperature		
Horizontal installation		0°C to +55°C
Vertical installation		0°C to +50°C
Relative humidity		5 to 95%, non-condensing
Mounting orientation		Horizontal or vertical
Installation at altitudes above sea level		
0 - 2000 m		No derating
>2000 m		Reduction of ambient temperature by 0.5°C per 100 m
Protection type		IP20
<b>Storage and transport conditions</b>		<b>X20CS1020</b>
Temperature		-25°C to +70°C
Relative humidity		5 to 95%, non-condensing
<b>Mechanical characteristics</b>		<b>X20CS1020</b>
Spacing		12.5 <sup>+0.2</sup> mm
Comment		Order terminal block 1x X20TB06 or X20TB12 separately Order bus module 1x X20BM11 separately

## Pin assignments

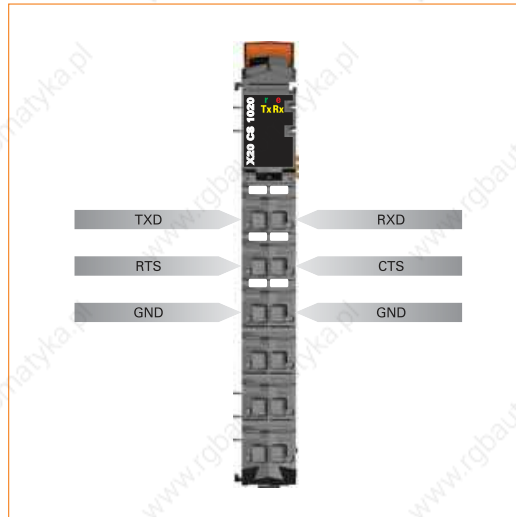

### Required accessories

X20TB06	X20 terminal block, 6-pin, 24 V coded	94
X20TB12	X20 terminal block, 12-pin, 24 V coded	94
X20BM11	X20 bus module, 24 V coded, internal I/O supply is interconnected	88

## Interface module CS1030



- RS485/RS422 interface for serial, remote connection of complex devices to the X20 System
- Integrated terminating resistor

<b>Short description</b>	<b>X20CS1030</b>
Communication module	1x RS485/RS422
<b>Interfaces</b>	<b>X20CS1030</b>
Interface IF1	
Type	RS485/RS422
Design	Contact via 12-pin terminal block TB12
Maximum transfer rate	250 kBit/s
<b>General information</b>	<b>X20CS1030</b>
Status indicators	Data transfer, terminating resistor, operating status, module status
Diagnostics	
Module run/error	Yes, with status LED and software status
Data transfer	Yes, with status LED
Terminating resistor	Yes, with status LED
Electrical isolation	
IF1 - Bus	Yes
IF1 - I/O supply	Yes
Power consumption	
Bus	0.01 W
I/O internal	1.44 W
Certification	CE, C-UL-US, GOST-R
<b>Operational conditions</b>	<b>X20CS1030</b>
Operating temperature	
Horizontal installation	0°C to +55°C
Vertical installation	0°C to +50°C
Relative humidity	5 to 95%, non-condensing
Mounting orientation	Horizontal or vertical
Installation at altitudes above sea level	
0 - 2000 m	No derating
>2000 m	Reduction of ambient temperature by 0.5°C per 100 m
Protection type	IP20
<b>Storage and transport conditions</b>	<b>X20CS1030</b>
Temperature	-25°C to +70°C
Relative humidity	5 to 95%, non-condensing
<b>Mechanical characteristics</b>	<b>X20CS1030</b>
Spacing	12.5 <sup>+0.2</sup> mm
Comment	Order terminal block 1x X20TB06 or X20TB12 separately Order bus module 1x X20BM11 separately

## Pin assignments



Required accessories		
X20TB06	X20 terminal block, 6-pin, 24 V coded	94
X20TB12	X20 terminal block, 12-pin, 24 V coded	94
X20BM11	X20 bus module, 24 V coded, internal I/O supply is interconnected	88

## Interface module CS1070



- CAN bus interface for serial, remote connection of complex devices to the X20 System
- Integrated terminating resistor

# CAN

<b>Short description</b>	<b>X20CS1070</b>
Communication module	1x CAN bus
<b>Interfaces</b>	<b>X20CS1070</b>
Interface IF1	
Type	CAN bus
Design	Contact via 12-pin terminal block TB12
Maximum transfer rate	1 MBit/s
<b>General information</b>	<b>X20CS1070</b>
Status indicators	Data transfer, terminating resistor, operating status, module status
Diagnostics	
Module run/error	Yes, with status LED and software status
Data transfer	Yes, with status LED
Terminating resistor	Yes, with status LED
Electrical isolation	
IF1 - Bus	Yes
IF1 - I/O supply	Yes
Power consumption	
Bus	0.01 W
I/O internal	1.44 W
Certification	CE, C-UL-US, GOST-R
<b>Operational conditions</b>	<b>X20CS1070</b>
Operating temperature	
Horizontal installation	0°C to +55°C
Vertical installation	0°C to +50°C
Relative humidity	5 to 95%, non-condensing
Mounting orientation	Horizontal or vertical
Installation at altitudes above sea level	
0 - 2000 m	No derating
>2000 m	Reduction of ambient temperature by 0.5°C per 100 m
Protection type	IP20
<b>Storage and transport conditions</b>	<b>X20CS1070</b>
Temperature	-25°C to +70°C
Relative humidity	5 to 95%, non-condensing
<b>Mechanical characteristics</b>	<b>X20CS1070</b>
Spacing	12.5 <sup>+0.2</sup> mm
Comment	Order terminal block 1x X20TB06 or X20TB12 separately Order bus module 1x X20BM11 separately

## Pin assignments



### Required accessories

X20TB06	X20 terminal block, 6-pin, 24 V coded	94
X20TB12	X20 terminal block, 12-pin, 24 V coded	94
X20BM11	X20 bus module, 24 V coded, internal I/O supply is interconnected	88

## Interface module CS2770



- 2 CAN bus interfaces for serial, remote connection of complex devices to the X20 System
- Integrated terminating resistors

# CAN

<b>Short description</b>	<b>X20CS2770</b>
Communication module	2x CAN bus
<b>Interfaces</b>	<b>X20CS2770</b>
<b>Interface IF1</b>	
Type	CAN bus
Design	Contact via 12-pin terminal block TB12
Maximum transfer rate	1 MBit/s
<b>Interface IF2</b>	
Type	CAN bus
Design	Contact via 12-pin terminal block TB12
Maximum transfer rate	1 MBit/s
<b>General information</b>	<b>X20CS2770</b>
Status indicators	Data transfer, terminating resistor, operating status, module status
<b>Diagnostics</b>	
Module run/error	Yes, with status LED and software status
Data transfer	Yes, with status LED
Terminating resistor	Yes, with status LED
<b>Electrical isolation</b>	
IF1/F2 - Bus	Yes
IF1/F2 - I/O supply	Yes
IF1 - IF2	Yes
<b>Power consumption</b>	
Bus	0.01 W
I/O internal	1.5 W
Certification	CE, C-UL-US, GOST-R
<b>Operational conditions</b>	<b>X20CS2770</b>
<b>Operating temperature</b>	
Horizontal installation	0°C to +55°C
Vertical installation	0°C to +50°C
Relative humidity	5 to 95%, non-condensing
Mounting orientation	Horizontal or vertical
<b>Installation at altitudes above sea level</b>	
0 - 2000 m	No derating
>2000 m	Reduction of ambient temperature by 0.5°C per 100 m
Protection type	IP20
<b>Storage and transport conditions</b>	<b>X20CS2770</b>
Temperature	-25°C to +70°C
Relative humidity	5 to 95%, non-condensing
<b>Mechanical characteristics</b>	<b>X20CS2770</b>
Spacing	12.5 <sup>+0.2</sup> mm
Comment	Order terminal block 1x X20TB12 separately Order bus module 1x X20BM11 separately

## Pin assignments



### Required accessories

X20TB12	X20 terminal block, 12-pin, 24 V coded	94
X20BM11	X20 bus module, 24 V coded, internal I/O supply is interconnected	88

# Bus receivers BR9300



The bus receiver BR9300 is used to connect the X20 system to the X2X link. The module is equipped with a feed for the X2X Link as well as the internal I/O supply. The left and right locking plates are included in the delivery.

- X2X Link bus receiver
- Supply for X2X Link and internal I/O supply
- Electrical isolation of feed and X2X Link supply
- X2X Link supply redundancy possible by using several supply modules at the same time

<b>Short description</b>	<b>X20BR9300</b>
Bus receivers	X2X Link bus receiver with supply for I/O and bus
<b>X2X Link supply input</b>	<b>X20BR9300</b>
Input voltage	24 VDC (-15% / +20%)
Input current	Max. 0.7 A
Reverse polarity protection	Yes
Fuse	Integrated, cannot be exchanged
<b>X2X Link supply output</b>	<b>X20BR9300</b>
Rated output power	7.0 W
Parallel operation	Yes <sup>1)</sup>
Redundant operation	Yes
<small>1) In parallel operation, only 75% of the rated power can be assumed. Please ensure that all parallel operating power supplies are switched on and off simultaneously.</small>	
<b>Input I/O supply</b>	<b>X20BR9300</b>
Input voltage	24 VDC (-15% / +20%)
Fuse	Recommended pre-fusing max. 10 A slow-blow
<b>Output I/O supply</b>	<b>X20BR9300</b>
Rated output voltage	24 VDC
Permitted contact load	10.0 A
<b>General information</b>	<b>X20BR9300</b>
Status indicators	X2X bus function, overload, operating status, module status
Diagnostics	
Module run/error	Yes, with status LED and software status
X2X bus function	Yes, with status LED
Overload	Yes, with status LED and software status
Electrical isolation	
X2X Link supply	Yes
I/O supply	No
Power consumption <sup>1)</sup>	
Bus	1.62 W
I/O internal	0.6 W
Certification	CE, C-UL-US, GOST-R
<small>1) The specified values are maximum values. The exact calculation is available for download as a data sheet with the other module documentation on the B&amp;R homepage.</small>	
<b>Operational conditions</b>	<b>X20BR9300</b>
Operating temperature	
Horizontal installation	0°C to +55°C
Vertical installation	0°C to +50°C
Relative humidity	5 to 95%, non-condensing
Mounting orientation	Horizontal or vertical
Installation at altitudes above sea level	
0 - 2000 m	No derating
>2000 m	Reduction of ambient temperature by 0.5°C per 100 m
Protection type	IP20
<b>Storage and transport conditions</b>	<b>X20BR9300</b>
Temperature	-25°C to +70°C
Relative humidity	5 to 95%, non-condensing
<b>Mechanical characteristics</b>	<b>X20BR9300</b>
Spacing	12.5 <sup>+0.2</sup> mm
Comment	Order terminal block 1x X20TB12 separately Order supply bus module 1x X20BM01 separately Left and right X20 end plates included in delivery

## Pin assignments

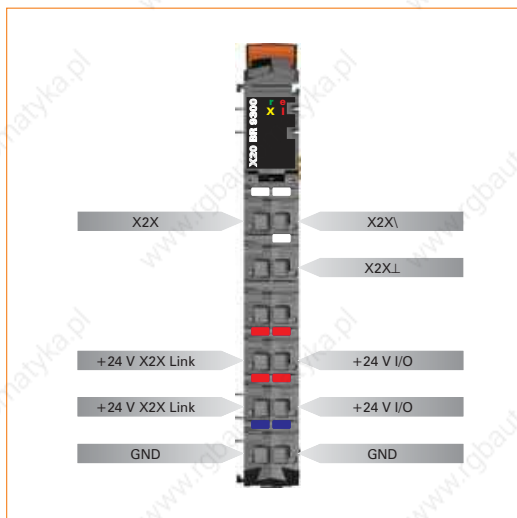

## Connection example

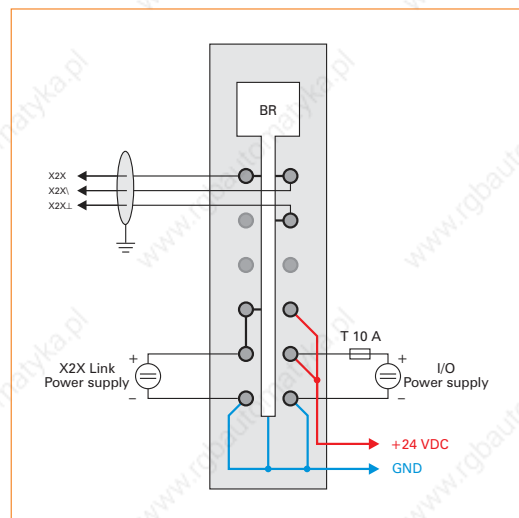

### Required accessories

X20TB12	X20 terminal block, 12-pin, 24 V coded	94
X20BM01	X20 supply bus module, internal I/O supply is isolated to the left	86

### Optional accessories

X67CA0X99.1000	Cable for custom prefabrication, 100.0 m
----------------	--

## Bus transmitters BT9100



The bus transmitter BT9100 provides for the seamless expansion of the X20 system. The stations can be up to 100 m away from each other.

- X2X Link bus transmitter
- For seamless expansion of the systems
- Up to 100 m segment lengths
- Feed for internal I/O power supply

**Note:**

If the feed is being used for internal I/O supply, this potential group cannot be supplied by any other module. An I/O module with bus module BM01 should be used to separate the potential group (see section "Supply feed via bus transmitter", on page 404).

<b>Short description</b>	<b>X20BT9100</b>
Bus transmitters	X2X Link bus transmitter with supply for I/O
<b>Input I/O supply</b>	<b>X20BT9100</b>
Input voltage	24 VDC (-15% / +20%)
Fuse	Recommended pre-fusing max. 10 A slow-blow
<b>Output I/O supply</b>	<b>X20BT9100</b>
Rated output voltage	24 VDC
Permitted contact load	10.0 A
<b>General information</b>	<b>X20BT9100</b>
Status indicators	X2X bus function, operating status, module status
Diagnostics	
Module run/error	Yes, with status LED and software status
X2X bus function	Yes, with status LED
Power consumption <sup>1)</sup>	
Bus	0.5 W
I/O internal	
as bus transmitter	0.1 W
additionally as supply module	0.6 W
Certification	CE, C-UL-US, GOST-R
<small>1) The specified values are maximum values. The exact calculation is available for download as a data sheet with the other module documentation on the B&amp;R homepage.</small>	
<b>Operational conditions</b>	<b>X20BT9100</b>
Operating temperature	
Horizontal installation	0°C to +55°C
Vertical installation	0°C to +50°C
Relative humidity	5 to 95%, non-condensing
Mounting orientation	Horizontal or vertical
Installation at altitudes above sea level	
0 - 2000 m	No derating
>2000 m	Reduction of ambient temperature by 0.5°C per 100 m
Protection type	IP20
<b>Storage and transport conditions</b>	<b>X20BT9100</b>
Temperature	-25°C to +70°C
Relative humidity	5 to 95%, non-condensing
<b>Mechanical characteristics</b>	<b>X20BT9100</b>
Spacing	12.5 <sup>+0.2</sup> mm
Comment	Order terminal block 1x X20TB06 or X20TB12 separately Order bus module 1x X20BM11 separately

## Pin assignments



## Connection example

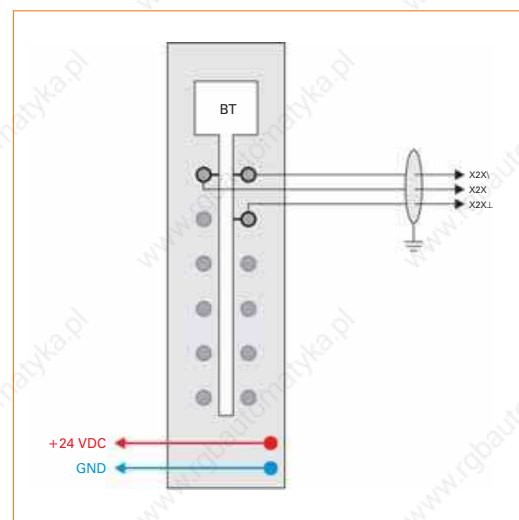

### Required accessories

X20TB06	X20 terminal block, 6-pin, 24 V coded	94
X20TB12	X20 terminal block, 12-pin, 24 V coded	94
X20BM11	X20 bus module, 24 V coded, internal I/O supply is interconnected	88

### Optional accessories

X67CA0X99.1000	Cable for custom prefabrication, 100.0 m	
----------------	--	--

## Bus transmitters BT9400



To make a connection from an X20 System to an X67 System, a bus transmitter is simply plugged into the end of the X20 block in order to connect the X2X Link cable. The BT9400 bus transmitter also provides the X2X supply voltage for the X67 System. The X67 system supply module that was previously required is no longer needed.

- X2X Link bus transmitter
- For seamless expansion of the systems
- Up to 100 m segment lengths
- Feed for internal I/O power supply
- Integrated X2X Link supply for the X67 System

### Note:

If the feed is being used for internal I/O supply, this potential group cannot be supplied by any other module. An I/O module with bus module BM01 should be used to separate the potential group (see section "Supply feed via bus transmitter", on page 404).

<b>Short description</b>	<b>X20BT9400</b>
Bus transmitters	X2X Link bus transmitter with supply for I/O and integrated X67 System supply
<b>X67 X2X Link supply input</b>	<b>X20BT9400</b>
Input voltage	24 VDC (-15% / +20%)
Input current	Max. 0.5 A
Reverse polarity protection	Yes
Fuse	Integrated, cannot be exchanged
<b>X67 X2X Link supply output</b>	<b>X20BT9400</b>
Number of X67 modules	
Horizontal installation	Max. 8
Vertical installation	Max. 6
Parallel connection with X67PS1300	Yes <sup>1)</sup>
<small>1) Only the PS1300 can be used for calculating the total number of X67 modules.</small>	
<b>Input I/O supply</b>	<b>X20BT9400</b>
Input voltage	24 VDC (-15% / +20%)
Fuse	Recommended pre-fusing max. 10 A slow-blow
<b>Output I/O supply</b>	<b>X20BT9400</b>
Rated output voltage	24 VDC
Permitted contact load	10.0 A
<b>General information</b>	<b>X20BT9400</b>
Status indicators	X2X bus function, operating status, module status
Diagnosics	
Module run/error	Yes, with status LED and software status
X2X bus function	Yes, with status LED
Power consumption <sup>1)</sup>	
Bus	0.5 W
I/O internal	
as bus transmitter	0.1 W
additionally as supply module	0.6 W
X67 X2X Link (internal)	1.38 W
Certification	CE, C-UL-US (in development), GOST-R
<small>1) The specified values are maximum values. The exact calculation is available for download as a data sheet with the other module documentation on the B&amp;R homepage.</small>	
<b>Operational conditions</b>	<b>X20BT9400</b>
Operating temperature	
Horizontal installation	0°C to +55°C
Vertical installation	0°C to +50°C
Relative humidity	5 to 95%, non-condensing
Mounting orientation	Horizontal or vertical
Installation at altitudes above sea level	
0 - 2000 m	No derating
>2000 m	Reduction of ambient temperature by 0.5°C per 100 m
Protection type	IP20
<b>Storage and transport conditions</b>	<b>X20BT9400</b>
Temperature	-25°C to +70°C
Relative humidity	5 to 95%, non-condensing
<b>Mechanical characteristics</b>	<b>X20BT9400</b>
Spacing	12.5 <sup>+0.2</sup> mm
Comment	Order terminal block 1x X20TB12 separately Order bus module 1x X20BM11 separately

## Pin assignments

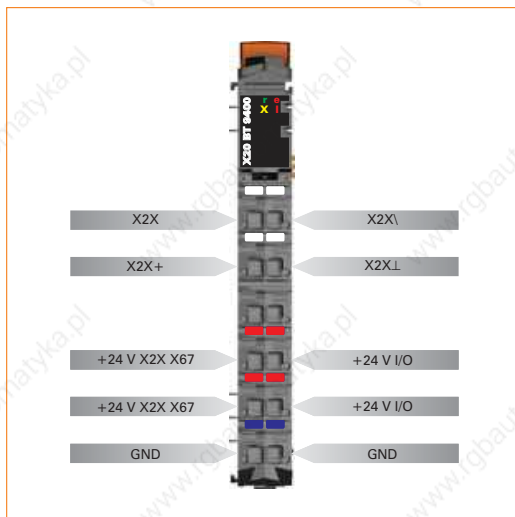

## Connection example

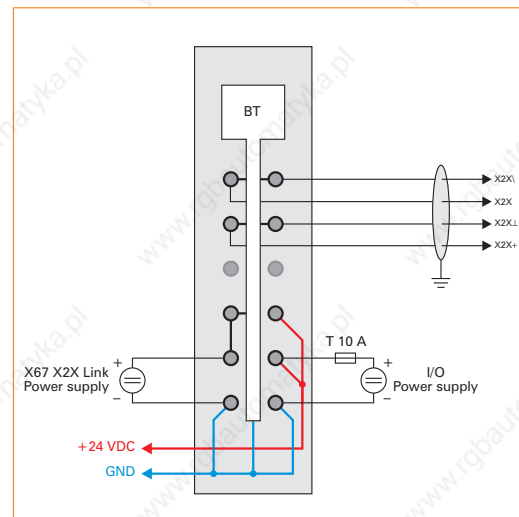

### Required accessories

X20TB12	X20 terminal block, 12-pin, 24 V coded	94
X20BM11	X20 bus module, 24 V coded, internal I/O supply is interconnected	88

### Optional accessories

X67CA0X99.1000	Cable for custom prefabrication, 100.0 m
----------------	--

## Supply module PS2100



- 24 VDC supply module for internal I/O supply

<b>Short description</b>	<b>X20PS2100</b>
Power supply module	24 VDC supply module for internal I/O supply
<b>Input I/O supply</b>	<b>X20PS2100</b>
Input voltage	24 VDC (-15% / +20%)
Fuse	Recommended pre-fusing max. 10 A slow-blow
<b>Output I/O supply</b>	<b>X20PS2100</b>
Rated output voltage	24 VDC
Permitted contact load	10.0 A
<b>General information</b>	<b>X20PS2100</b>
Status indicators	Operating status, module status
Diagnostics	
Module run/error	Yes, with status LED and software status
Electrical isolation	
I/O supply	No
<b>Power consumption <sup>1)</sup></b>	
Bus	0.2 W
I/O internal	0.6 W
Certification	CE, C-UL-US, GOST-R, BG-PRÜFZERT <sup>2)</sup>
<sup>1)</sup> The specified values are maximum values. The exact calculation is available for download as a data sheet with the other module documentation on the B&R homepage. <sup>2)</sup> Operating principle checked: Shutdown initiated by external safety switching device	
<b>Operational conditions</b>	<b>X20PS2100</b>
Operating temperature	
Horizontal installation	0°C to +55°C
Vertical installation	0°C to +50°C
Relative humidity	5 to 95%, non-condensing
Mounting orientation	Horizontal or vertical
Installation at altitudes above sea level	
0 - 2000 m	No derating
>2000 m	Reduction of ambient temperature by 0.5°C per 100 m
Protection type	IP20
<b>Storage and transport conditions</b>	<b>X20PS2100</b>
Temperature	-25°C to +70°C
Relative humidity	5 to 95%, non-condensing
<b>Mechanical characteristics</b>	<b>X20PS2100</b>
Spacing	12.5 <sup>+0.2</sup> mm
Comment	Order terminal block 1x X20TB12 separately Order supply bus module 1x X20BM01 separately

### Pin assignments



### Connection example

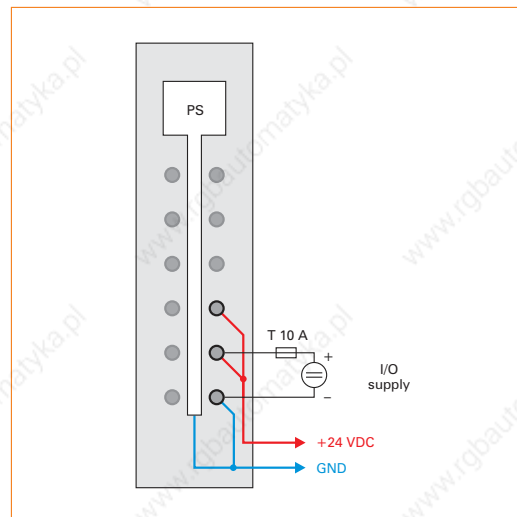

#### Required accessories

X20TB12	X20 terminal block, 12-pin, 24 V coded	94
X20BM01	X20 supply bus module, internal I/O supply is isolated to the left	86

## Supply module PS2110



- 24 VDC supply module for internal I/O supply
- Fuse for I/O supply integrated in module

<b>Short description</b>	<b>X20PS2110</b>
Power supply module	24 VDC supply module for internal I/O supply
<b>Input I/O supply</b>	<b>X20PS2110</b>
Input voltage	24 VDC (-15% / +20%)
Fuse	Integrated T 6.3 A, exchangeable
<b>Output I/O supply</b>	<b>X20PS2110</b>
Rated output voltage	24 VDC
Permitted contact load	10.0 A
<b>General information</b>	<b>X20PS2110</b>
Status indicators	Operating status, module status
Diagnostics	
Module run/error	Yes, with status LED and software status
Electrical isolation	
I/O supply	No
<b>Power consumption <sup>1)</sup></b>	
Bus	0.2 W
I/O internal	0.82 W
Certification	CE, C-UL-US, GOST-R, BG-PRÜFZERT <sup>2)</sup>
<sup>1)</sup> The specified values are maximum values. The exact calculation is available for download as a data sheet with the other module documentation on the B5R homepage. <sup>2)</sup> Operating principle checked: Shutdown initiated by external safety switching device	
<b>Operational conditions</b>	<b>X20PS2110</b>
Operating temperature	
Horizontal installation	0°C to +55°C
Vertical installation	0°C to +50°C
Relative humidity	5 to 95%, non-condensing
Mounting orientation	Horizontal or vertical
Installation at altitudes above sea level	
0 - 2000 m	No derating
>2000 m	Reduction of ambient temperature by 0.5°C per 100 m
Protection type	IP20
<b>Storage and transport conditions</b>	<b>X20PS2110</b>
Temperature	-25°C to +70°C
Relative humidity	5 to 95%, non-condensing
<b>Mechanical characteristics</b>	<b>X20PS2110</b>
Spacing	12.5 <sup>+0.2</sup> mm
Comment	Order terminal block 1x X20TB12 separately Order supply bus module 1x X20BM01 separately

### Pin assignments



### Connection example

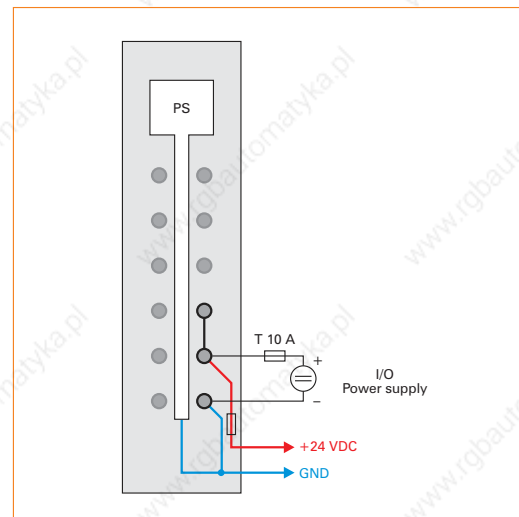

#### Required accessories

X20TB12	X20 terminal block, 12-pin, 24 V coded	94
X20BM01	X20 supply bus module, internal I/O supply is isolated to the left	86

# Supply module PS3300



- Supply for X2X Link and internal I/O supply
- Electrical isolation of feed and X2X Link supply
- Redundancy of X2X Link supply possible by operating multiple supply modules at the same time

<b>Short description</b>	<b>X20PS3300</b>
Power supply module	24 VDC supply module for I/O and bus
<b>X2X Link supply input</b>	<b>X20PS3300</b>
Input voltage	24 VDC (-15% / +20%)
Input current	Max. 0.7 A
Reverse polarity protection	Yes
Fuse	Integrated, cannot be exchanged
<b>X2X Link supply output</b>	<b>X20PS3300</b>
Rated output power	7.0 W
Parallel operation	Yes <sup>1)</sup>
Redundant operation	Yes
<small>1) In parallel operation, only 75% of the rated power can be assumed. Please ensure that all parallel operating power supplies are switched on and off simultaneously.</small>	
<b>Input I/O supply</b>	<b>X20PS3300</b>
Input voltage	24 VDC (-15% / +20%)
Fuse	Recommended pre-fusing max. 10 A slow-blow
<b>Output I/O supply</b>	<b>X20PS3300</b>
Rated output voltage	24 VDC
Permitted contact load	10.0 A
<b>General information</b>	<b>X20PS3300</b>
Status indicators	Overload, operating status, module status
Diagnostics	
Module run/error	Yes, with status LED and software status
Overload	Yes, with status LED and software status
Electrical isolation	
X2X Link supply	Yes
I/O supply	No
Power consumption <sup>1)</sup>	
Bus	1.31 W
I/O internal	0.6 W
Certification	CE, C-UL-US, GOST-R
<small>1) The specified values are maximum values. The exact calculation is available for download as a data sheet with the other module documentation on the B&amp;R homepage.</small>	
<b>Operational conditions</b>	<b>X20PS3300</b>
Operating temperature	
Horizontal installation	0°C to +55°C
Vertical installation	0°C to +50°C
Relative humidity	5 to 95%, non-condensing
Mounting orientation	Horizontal or vertical
Installation at altitudes above sea level	
0 - 2000 m	No derating
>2000 m	Reduction of ambient temperature by 0.5°C per 100 m
Protection type	IP20
<b>Storage and transport conditions</b>	<b>X20PS3300</b>
Temperature	-25°C to +70°C
Relative humidity	5 to 95%, non-condensing
<b>Mechanical characteristics</b>	<b>X20PS3300</b>
Spacing	12.5 <sup>+0.2</sup> mm
Comment	Order terminal block 1x X20TB12 separately Order supply bus module 1x X20BM01 separately

### Pin assignments

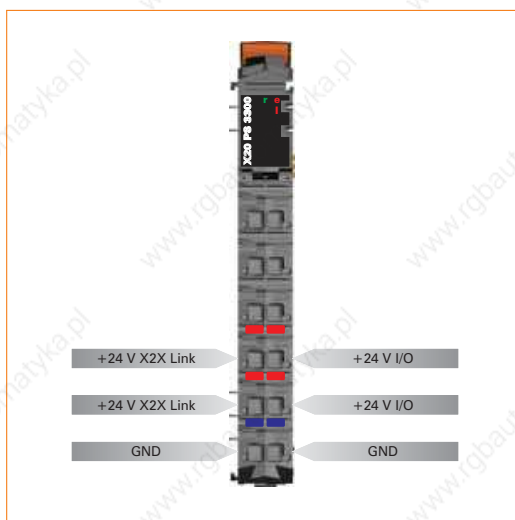

### Connection example

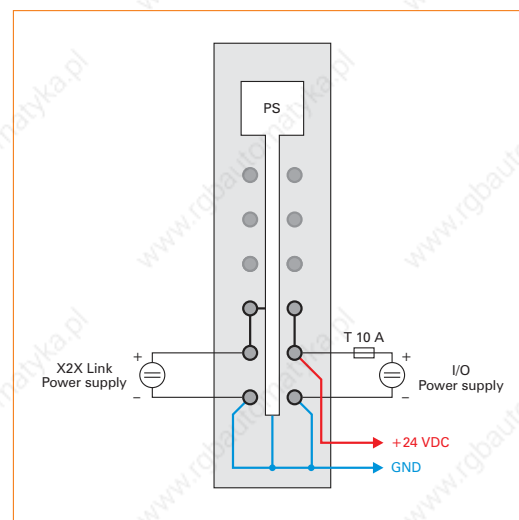

#### Required accessories

X20TB12	X20 terminal block, 12-pin, 24 V coded	94
X20BM01	X20 supply bus module, internal I/O supply is isolated to the left	86

# Supply module PS3310



- Supply for X2X Link and internal I/O supply
- Electrical isolation of feed and X2X Link supply
- Redundancy of X2X Link supply possible by operating multiple supply modules at the same time
- Fuse for I/O supply integrated in module

<b>Short description</b>	<b>X20PS3310</b>
Power supply module	24 VDC supply module for I/O and bus
<b>Input X2X bus supply</b>	<b>X20PS3310</b>
Input voltage	24 VDC (-15% / +20%)
Input current	Max. 0.7 A
Reverse polarity protection	Yes
Fuse	Integrated, cannot be exchanged
<b>Output X2X bus supply</b>	<b>X20PS3310</b>
Rated output power	7.0 W
Parallel operation	Yes <sup>1)</sup>
Redundant operation	Yes
1) In parallel operation, only 75% of the rated power can be assumed. Please ensure that all parallel operating power supplies are switched on and off simultaneously.	
<b>Input I/O supply</b>	<b>X20PS3310</b>
Input voltage	24 VDC (-15% / +20%)
Fuse	Integrated T 6.3 A, exchangeable
<b>Output I/O supply</b>	<b>X20PS3310</b>
Rated output voltage	24 VDC
Permitted contact load	10.0 A
<b>General information</b>	<b>X20PS3310</b>
Status indicators	Overload, operating status, module status
Diagnostics	
Module run/error	Yes, with status LED and software status
Overload	Yes, with status LED and software status
Electrical isolation	
X2X bus supply	Yes
I/O supply	No
Power consumption <sup>1)</sup>	
Bus	1.31 W
I/O internal	0.82 W
Certification	CE, C-UL-US, GOST-R
1) The specified values are maximum values. The exact calculation is available for download as a data sheet with the other module documentation on the B&R homepage.	
<b>Operational conditions</b>	<b>X20PS3310</b>
Operating temperature	
Horizontal installation	0°C to +55°C
Vertical installation	0°C to +50°C
Relative humidity	5 to 95%, non-condensing
Mounting orientation	Horizontal or vertical
Installation at altitudes above sea level	
0 - 2000 m	No derating
>2000 m	Reduction of ambient temperature by 0.5°C per 100 m
Protection type	IP20
<b>Storage and transport conditions</b>	<b>X20PS3310</b>
Temperature	-25°C to +70°C
Relative humidity	5 to 95%, non-condensing
<b>Mechanical characteristics</b>	<b>X20PS3310</b>
Spacing	12.5 <sup>+0.2</sup> mm
Comment	Order terminal block 1x X20TB12 separately Order supply bus module 1x X20BM01 separately

### Pin assignments

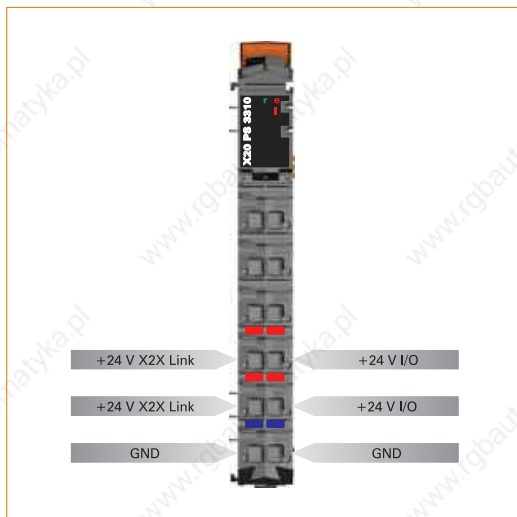

### Connection example

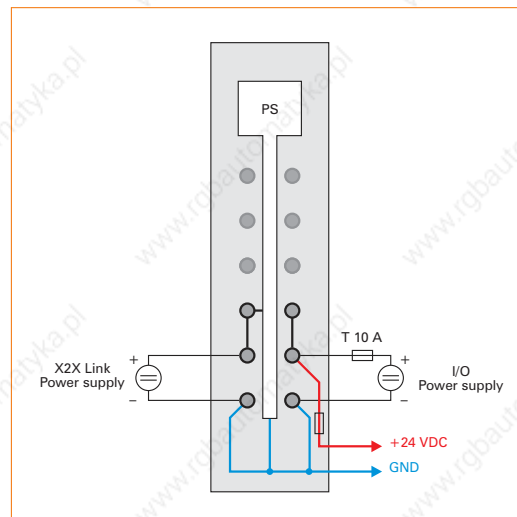

#### Required accessories

X20TB12	X20 terminal block, 12-pin, 24 V coded	94
X20BM01	X20 supply bus module, internal I/O supply is isolated to the left	86

## Digital input module DI2371



- 2 digital inputs
- Sink connection
- 3-wire connection
- 24 VDC and GND for sensor supply
- Software input filter can be configured for the entire module

<b>Short description</b>	<b>X20DI2371</b>
I/O module	Two 24 VDC digital inputs for 3-line connections
<b>Digital inputs</b>	<b>X20DI2371</b>
Rated voltage	24 VDC
Input filter	
Hardware	≤100 μs
Software	Default 1 ms, can be configured between 0 and 25 ms in 0.2 ms intervals
Connection type	3-line connections
Input circuit	Sink
Sensor supply	0.5 A total current
<b>General information</b>	<b>X20DI2371</b>
Status indicators	I/O function per channel, operating state, module status
Diagnostics	
Module run/error	Yes, with status LED and software status
Electrical isolation	
Channel - Bus	Yes
Channel - Channel	No
Power consumption	
Bus	0.12 W
I/O internal	0.29 W
Certification	CE, C-UL-US, GOST-R
<b>Operational conditions</b>	<b>X20DI2371</b>
Operating temperature	
Horizontal installation	0°C to +55°C
Vertical installation	0°C to +50°C
Relative humidity	5 to 95%, non-condensing
Mounting orientation	Horizontal or vertical
Installation at altitudes above sea level	
0 - 2000 m	No derating
>2000 m	Reduction of ambient temperature by 0.5°C per 100 m
Protection type	IP20
<b>Storage and transport conditions</b>	<b>X20DI2371</b>
Temperature	-25°C to +70°C
Relative humidity	5 to 95%, non-condensing
<b>Mechanical characteristics</b>	<b>X20DI2371</b>
Spacing	12.5 <sup>+0.2</sup> mm
Comment	Order terminal block 1x X20TB06 or X20TB12 separately Order bus module 1x X20BM11 separately

*The module is designed for X20 6-pin terminal blocks. However, the 12-pin terminal block can also be used.*

## Pin assignments

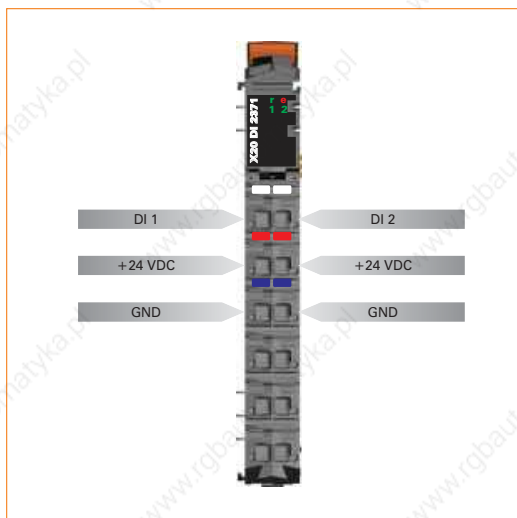

## Connection example

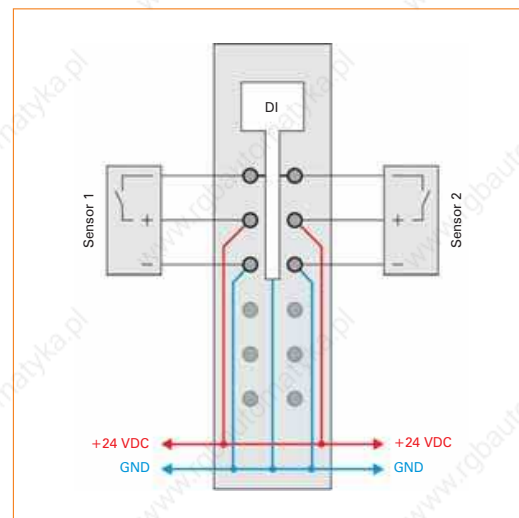

### Required accessories

X20TB06	X20 terminal block, 6-pin, 24 V coded	94
X20TB12	X20 terminal block, 12-pin, 24 V coded	94
X20BM11	X20 bus module, 24 V coded, internal I/O supply is interconnected	88

## Digital input module DI2372



- 2 digital inputs
- source connection
- 3-wire connection
- 24 VDC and GND for sensor supply
- Software input filter can be configured for the entire module

<b>Short description</b>	<b>X20DI2372</b>
I/O module	Two 24 VDC digital inputs for 3-line connections
<b>Digital inputs</b>	<b>X20DI2372</b>
Rated voltage	24 VDC
Input filter	
Hardware	≤100 μs
Software	Default 1 ms, can be configured between 0 and 25 ms in 0.2 ms intervals
Connection type	3-line connections
Input circuit	Source
Sensor supply	0.5 A total current
<b>General information</b>	<b>X20DI2372</b>
Status indicators	I/O function per channel, operating state, module status
Diagnostics	
Module run/error	Yes, with status LED and software status
Electrical isolation	
Channel - Bus	Yes
Channel - Channel	No
Power consumption	
Bus	0.12 W
I/O internal	0.29 W
Certification	CE, C-UL-US, GOST-R
<b>Operational conditions</b>	<b>X20DI2372</b>
Operating temperature	
Horizontal installation	0°C to +55°C
Vertical installation	0°C to +50°C
Relative humidity	5 to 95%, non-condensing
Mounting orientation	Horizontal or vertical
Installation at altitudes above sea level	
0 - 2000 m	No derating
>2000 m	Reduction of ambient temperature by 0.5°C per 100 m
Protection type	IP20
<b>Storage and transport conditions</b>	<b>X20DI2372</b>
Temperature	-25°C to +70°C
Relative humidity	5 to 95%, non-condensing
<b>Mechanical characteristics</b>	<b>X20DI2372</b>
Spacing	12.5 <sup>+0.2</sup> mm
Comment	Order terminal block 1x X20TB06 or X20TB12 separately Order bus module 1x X20BM11 separately

*The module is designed for X20 6-pin terminal blocks. However, the 12-pin terminal block can also be used.*

## Pin assignments



## Connection example

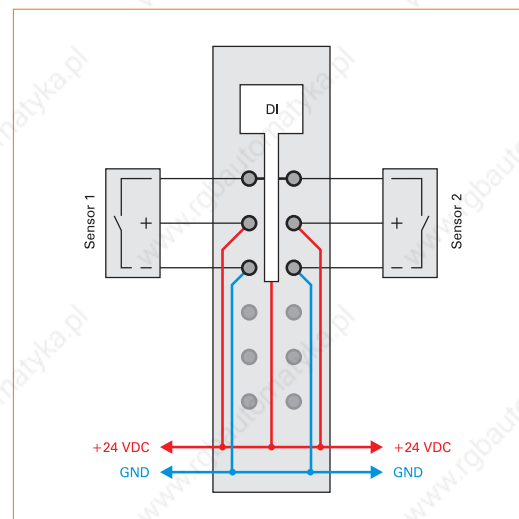

### Required accessories

X20TB06	X20 terminal block, 6-pin, 24 V coded	94
X20TB12	X20 terminal block, 12-pin, 24 V coded	94
X20BM11	X20 bus module, 24 V coded, internal I/O supply is interconnected	88

## Digital input module DI2377



- 2 digital inputs
- Sink connection
- 3-wire connection
- 2 counter inputs with 50 kHz counter frequency
- Gate measurement
- 24 VDC and GND for sensor supply
- Software input filter can be configured for the entire module

<b>Short description</b>	<b>X20DI2377</b>
I/O module	Two 24 VDC digital inputs for 3-line connections, special functions
<b>Digital inputs</b>	<b>X20DI2377</b>
Rated voltage	24 VDC
Input filter	
Hardware	≤10 μs
Software	Default 0 ms, can be configured between 0 and 25 ms in 0.2 ms intervals
Connection type	3-line connections
Input circuit	Sink
Additional functions for inputs	50 kHz event counting, gate measurement
Sensor supply	0.5 A total current
<b>General information</b>	<b>X20DI2377</b>
Status indicators	I/O function per channel, operating state, module status
Diagnosics	
Module run/error	Yes, with status LED and software status
Electrical isolation	
Channel - Bus	Yes
Channel - Channel	No
Power consumption	
Bus	0.15 W
I/O internal	0.82 W
Certification	CE, C-UL-US, GOST-R
<b>Operational conditions</b>	<b>X20DI2377</b>
Operating temperature	
Horizontal installation	0°C to +55°C
Vertical installation	0°C to +50°C
Relative humidity	5 to 95%, non-condensing
Mounting orientation	Horizontal or vertical
Installation at altitudes above sea level	
0 - 2000 m	No derating
>2000 m	Reduction of ambient temperature by 0.5°C per 100 m
Protection type	IP20
<b>Storage and transport conditions</b>	<b>X20DI2377</b>
Temperature	-25°C to +70°C
Relative humidity	5 to 95%, non-condensing
<b>Mechanical characteristics</b>	<b>X20DI2377</b>
Spacing	12.5 <sup>+0.2</sup> mm
Comment	Order terminal block 1x X20TB06 or X20TB12 separately Order bus module 1x X20BM11 separately

*The module is designed for X20 6-pin terminal blocks. However, the 12-pin terminal block can also be used.*

## Pin assignments

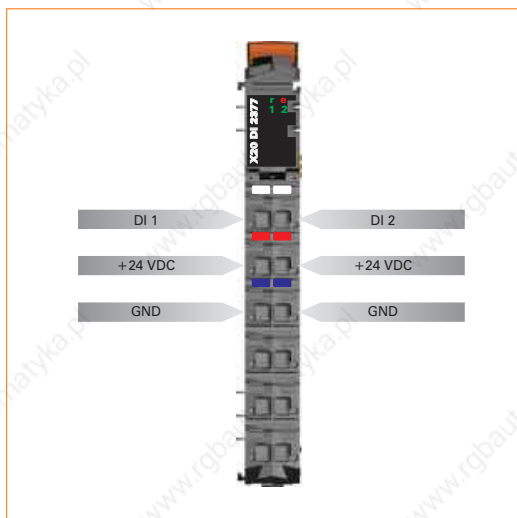

## Connection example

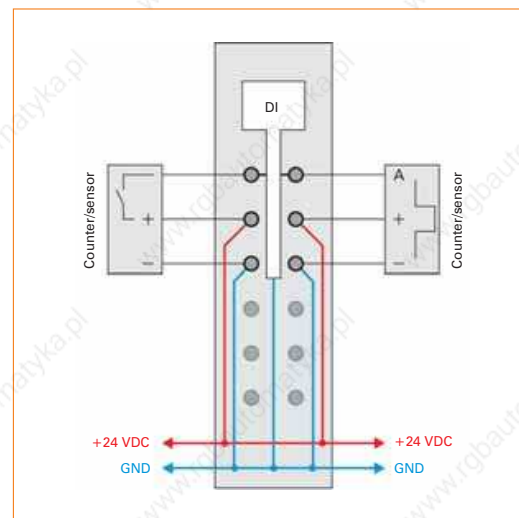

### Required accessories

X20TB06	X20 terminal block, 6-pin, 24 V coded	94
X20TB12	X20 terminal block, 12-pin, 24 V coded	94
X20BM11	X20 bus module, 24 V coded, internal I/O supply is interconnected	88

## Digital input module DI2653



- 2 digital inputs
- 120/240 VAC inputs
- 50 Hz or 60 Hz
- 3-wire connection
- Special color
- 240 V coded

<b>Short description</b>	<b>X20DI2653</b>
I/O module	2 digital inputs for 100 - 240 VAC, 3-line connections
<b>Digital inputs</b>	<b>X20DI2653</b>
Rated voltage	100 - 240 VAC
Rated frequency	47 - 63 Hz
Input filter	
Hardware	
0 → 1	≤40 ms
1 → 0	≤30 ms
Software	Default 1 ms. Can be configured between 0 and 25 ms in 0.2 ms intervals
Connection type	3-line connections
<b>General information</b>	<b>X20DI2653</b>
Status indicators	I/O function per channel, operating state, module status
Diagnostics	
Module run/error	Yes, with status LED and software status
I/O external supply	Yes, with software status (typical threshold 85 VAC)
Electrical isolation	
Channel - Bus	Yes
Channel - Channel	No
Power consumption	
Bus	0.14 W
I/O internal	-
I/O external	0.55 W
Certification	CE, C-UL-US, GOST-R
<b>Operational conditions</b>	<b>X20DI2653</b>
Operating temperature	
Horizontal installation	0°C to +55°C
Vertical installation	0°C to +50°C
Relative humidity	5 to 95%, non-condensing
Mounting orientation	Horizontal or vertical
Installation at altitudes above sea level	
0 - 2000 m	No derating
>2000 m	Reduction of ambient temperature by 0.5°C per 100 m
Protection type	IP20
<b>Storage and transport conditions</b>	<b>X20DI2653</b>
Temperature	-25°C to +70°C
Relative humidity	5 to 95%, non-condensing
<b>Mechanical characteristics</b>	<b>X20DI2653</b>
Spacing	12.5 <sup>+0.2</sup> mm
Comment	Order terminal block 1x X20TB32 separately Order bus module 1x X20BM12 separately

## Pin assignments

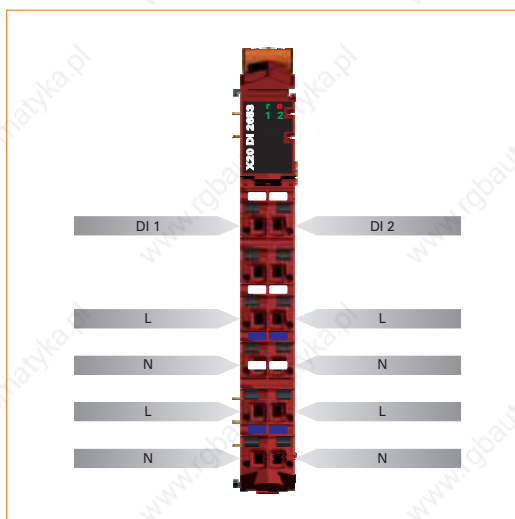

## Connection example

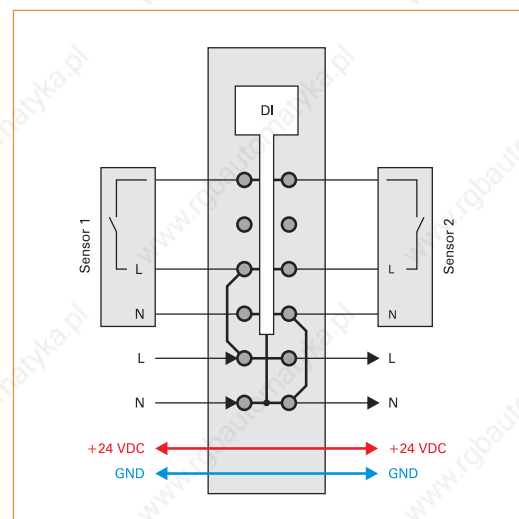

### Required accessories

X20TB32	X20 terminal block, 12-pin, 240 V coded	95
X20BM12	X20 bus module, 240 V coded, internal I/O supply is interconnected	89

## Digital input module DI4371



- 4 digital inputs
- Sink connection
- 3-wire connection
- 24 VDC and GND for sensor supply
- Software input filter can be configured for the entire module

<b>Short description</b>	<b>X20DI4371</b>
I/O module	Four 24 VDC digital inputs for 3-line connections
<b>Digital inputs</b>	<b>X20DI4371</b>
Rated voltage	24 VDC
Input filter	
Hardware	≤100 μs
Software	Default 1 ms, can be configured between 0 and 25 ms in 0.2 ms intervals
Connection type	3-line connections
Input circuit	Sink
Sensor supply	0.5 A total current
<b>General information</b>	<b>X20DI4371</b>
Status indicators	I/O function per channel, operating state, module status
Diagnostics	
Module run/error	Yes, with status LED and software status
Electrical isolation	
Channel - Bus	Yes
Channel - Channel	No
Power consumption	
Bus	0.14 W
I/O internal	0.59 W
Certification	CE, C-UL-US, GOST-R
<b>Operational conditions</b>	<b>X20DI4371</b>
Operating temperature	
Horizontal installation	0°C to +55°C
Vertical installation	0°C to +50°C
Relative humidity	5 to 95%, non-condensing
Mounting orientation	Horizontal or vertical
Installation at altitudes above sea level	
0 - 2000 m	No derating
>2000 m	Reduction of ambient temperature by 0.5°C per 100 m
Protection type	IP20
<b>Storage and transport conditions</b>	<b>X20DI4371</b>
Temperature	-25°C to +70°C
Relative humidity	5 to 95%, non-condensing
<b>Mechanical characteristics</b>	<b>X20DI4371</b>
Spacing	12.5 <sup>+0.2</sup> mm
Comment	Order terminal block 1x X20TB12 separately Order bus module 1x X20BM11 separately

### Pin assignments

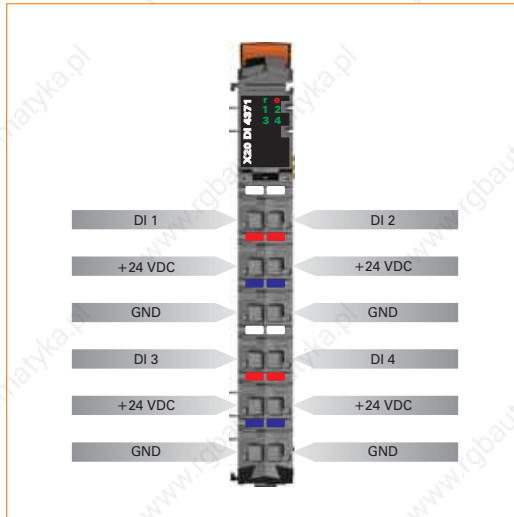

### Connection example

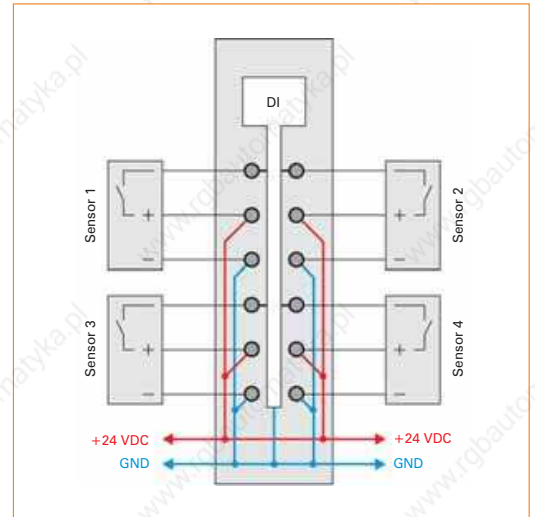

#### Required accessories

X20TB12	X20 terminal block, 12-pin, 24 V coded	94
X20BM11	X20 bus module, 24 V coded, internal I/O supply is interconnected	88

## Digital input module DI4372



- 4 digital inputs
- source connection
- 3-wire connection
- 24 VDC and GND for sensor supply
- Software input filter can be configured for the entire module

<b>Short description</b>	<b>X20DI4372</b>
I/O module	Four 24 VDC digital inputs for 3-line connections
<b>Digital inputs</b>	<b>X20DI4372</b>
Rated voltage	24 VDC
Input filter	
Hardware	≤100 μs
Software	Default 1 ms, can be configured between 0 and 25 ms in 0.2 ms intervals
Connection type	3-line connections
Input circuit	Source
Sensor supply	0.5 A total current
<b>General information</b>	<b>X20DI4372</b>
Status indicators	I/O function per channel, operating state, module status
Diagnostics	
Module run/error	Yes, with status LED and software status
Electrical isolation	
Channel - Bus	Yes
Channel - Channel	No
Power consumption	
Bus	0.14 W
I/O internal	0.59 W
Certification	CE, C-UL-US, GOST-R
<b>Operational conditions</b>	<b>X20DI4372</b>
Operating temperature	
Horizontal installation	0°C to +55°C
Vertical installation	0°C to +50°C
Relative humidity	5 to 95%, non-condensing
Mounting orientation	Horizontal or vertical
Installation at altitudes above sea level	
0 - 2000 m	No derating
>2000 m	Reduction of ambient temperature by 0.5°C per 100 m
Protection type	IP20
<b>Storage and transport conditions</b>	<b>X20DI4372</b>
Temperature	-25°C to +70°C
Relative humidity	5 to 95%, non-condensing
<b>Mechanical characteristics</b>	<b>X20DI4372</b>
Spacing	12.5 <sup>+0.2</sup> mm
Comment	Order terminal block 1x X20TB12 separately Order bus module 1x X20BM11 separately

### Pin assignments

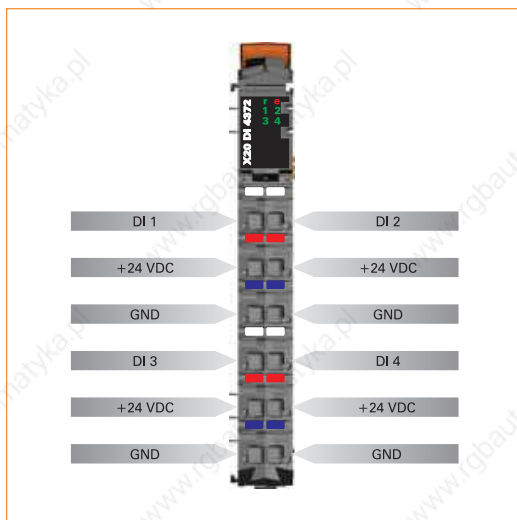

### Connection example

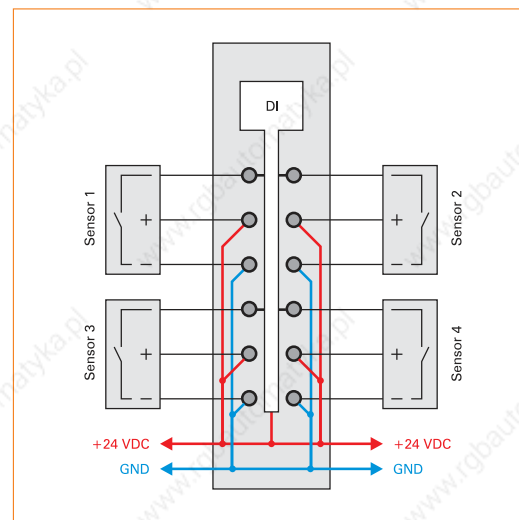

#### Required accessories

X20TB12	X20 terminal block, 12-pin, 24 V coded	94
X20BM11	X20 bus module, 24 V coded, internal I/O supply is interconnected	88

## Digital input module DI4653



- 4 digital inputs
- 120/240 VAC inputs
- 50 Hz or 60 Hz
- 2-wire connection
- Special color
- 240 V coded

<b>Short description</b>	<b>X20DI4653</b>
I/O module	4 digital inputs for 100 - 240 VAC, 2-line connections
<b>Digital inputs</b>	<b>X20DI4653</b>
Rated voltage	100 - 240 VAC
Rated frequency	47 - 63 Hz
Input filter	
Hardware	
0 → 1	≤40 ms
1 → 0	≤30 ms
Software	Default 1 ms, can be configured between 0 and 25 ms in 0.2 ms intervals
Connection type	2-line connections
<b>General information</b>	<b>X20DI4653</b>
Status indicators	I/O function per channel, operating state, module status
Diagnostics	
Module run/error	Yes, with status LED and software status
I/O external supply	Yes, with software status (typical threshold 85 VAC)
Electrical isolation	
Channel - Bus	Yes
Channel - Channel	No
Power consumption	
Bus	0.17 W
I/O internal	-
I/O external	0.91 W
Certification	CE, C-UL-US, GOST-R
<b>Operational conditions</b>	<b>X20DI4653</b>
Operating temperature	
Horizontal installation	0°C to +55°C
Vertical installation	0°C to +50°C
Relative humidity	5 to 95%, non-condensing
Mounting orientation	Horizontal or vertical
Installation at altitudes above sea level	
0 - 2000 m	No derating
>2000 m	Reduction of ambient temperature by 0.5°C per 100 m
Protection type	IP20
<b>Storage and transport conditions</b>	<b>X20DI4653</b>
Temperature	-25°C to +70°C
Relative humidity	5 to 95%, non-condensing
<b>Mechanical characteristics</b>	<b>X20DI4653</b>
Spacing	12.5 <sup>+0.2</sup> mm
Comment	Order terminal block 1x X20TB32 separately Order bus module 1x X20BM12 separately

### Pin assignments

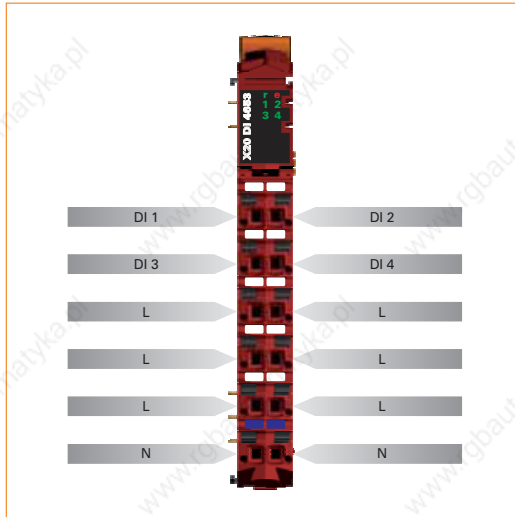

### Connection example

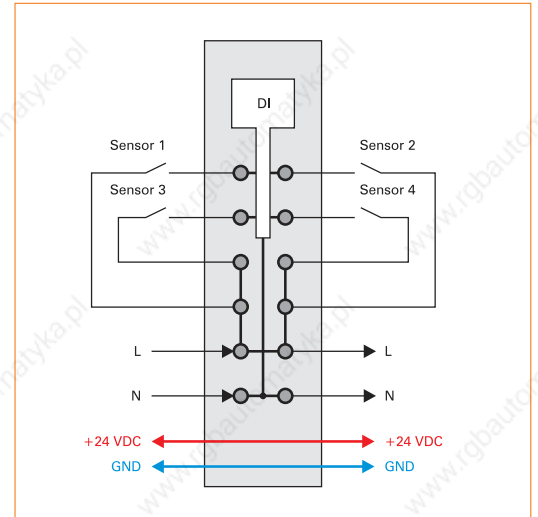

#### Required accessories

X20TB32	X20 terminal block, 12-pin, 240 V coded	95
X20BM12	X20 bus module, 240 V coded, internal I/O supply is interconnected	89

## Digital input module DI4760



- 4 digital inputs
- Input module for NAMUR encoders
- Open connection and short-circuit detection
- Every input can be used as a counter input

<b>Short description</b>	<b>X20DI4760</b>
I/O module	4 NAMUR inputs, special function
<b>NAMUR inputs</b>	<b>X20DI4760</b>
No load voltage	8.05 V ± 0.33%
Input delay	
1 input active	≤310 μs
2 inputs active	≤450 μs
3 inputs active	≤570 μs
4 inputs active	≤735 μs
Input circuit	For NAMUR encoders according to EN 60947-5-6
<b>Event counter</b>	<b>X20DI4760</b>
Amount	4
Counter size	8-bit
Input frequency	
1 input active	Max. 1600 Hz
2 inputs active	Max. 1100 Hz
3 inputs active	Max. 870 Hz
4 inputs active	Max. 680 Hz
Evaluation	Every positive edge, cyclic counter
Signal form	Symmetric square wave pulse or corresponding minimum pulse duration <sup>1)</sup>
1) Minimum pulse duration:	$t[s] \geq \frac{1}{2 \cdot f_{max}[Hz]}$
<b>General information</b>	<b>X20DI4760</b>
Status indicators	I/O function by channel, open line and short circuit detection by channel, operating status, module status
Diagnostics	
Module run/error	Yes, with status LED and software status
Open line	Yes, with status LED and software status
Short circuit	Yes, with status LED and software status
Electrical isolation	
Channel - Bus	Yes
Channel - Channel	No
Power consumption	
Bus	0.01 W
I/O internal	1.5 W
Certification	CE, C-UL-US, GOST-R
<b>Operational conditions</b>	<b>X20DI4760</b>
Operating temperature	
Horizontal installation	0°C to +55°C
Vertical installation	Values derated when mounted vertically
Relative humidity	5 to 95%, non-condensing
Mounting orientation	Horizontal or vertical
Installation at altitudes above sea level	
0 - 2000 m	No derating
>2000 m	Reduction of ambient temperature by 0.5°C per 100 m
Protection type	IP20
<b>Storage and transport conditions</b>	<b>X20DI4760</b>
Temperature	-25°C to +70°C
Relative humidity	5 to 95%, non-condensing
<b>Mechanical characteristics</b>	<b>X20DI4760</b>
Spacing	12.5 <sup>+0.2</sup> mm
Comment	Order terminal block 1x X20TB12 separately Order bus module 1x X20BM11 separately

### Pin assignments

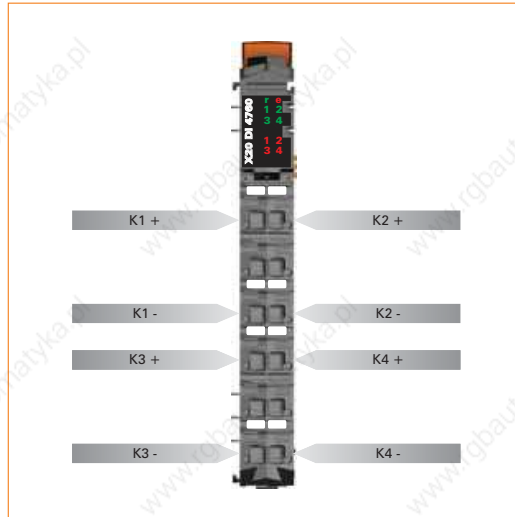

### Connection example

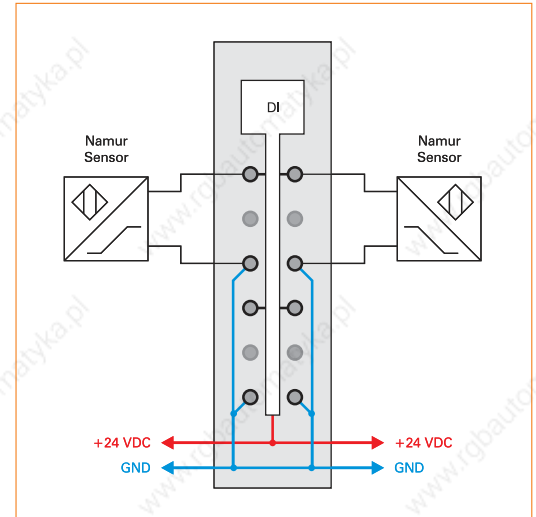

#### Required accessories

X20TB12	X20 terminal block, 12-pin, 24 V coded	94
X20BM11	X20 bus module, 24 V coded, internal I/O supply is interconnected	88

## Digital input module DI6371



- 6 digital inputs
- Sink connection
- 2-wire connection
- 24 VDC for sensor supply
- Software input filter can be configured for the entire module
- 1-line connection with 6-pin terminal block

<b>Short description</b>	<b>X20DI6371</b>
I/O module	Six 24 VDC digital inputs for 1 or 2-wire connections
<b>Digital inputs</b>	<b>X20DI6371</b>
Rated voltage	24 VDC
Input filter	
Hardware	≤100 μs
Software	Default 1 ms, can be configured between 0 and 25 ms in 0.2 ms intervals
Connection type	1 or 2 line connection
Input circuit	Sink
<b>General information</b>	<b>X20DI6371</b>
Status indicators	I/O function per channel, operating state, module status
Diagnostics	
Module run/error	Yes, with status LED and software status
Electrical isolation	
Channel - Bus	Yes
Channel - Channel	No
Power consumption	
Bus	0.15 W
I/O internal	0.88 W
Certification	CE, C-UL-US, GOST-R
<b>Operational conditions</b>	<b>X20DI6371</b>
Operating temperature	
Horizontal installation	0°C to +55°C
Vertical installation	0°C to +50°C
Relative humidity	5 to 95%, non-condensing
Mounting orientation	Horizontal or vertical
Installation at altitudes above sea level	
0 - 2000 m	No derating
>2000 m	Reduction of ambient temperature by 0.5°C per 100 m
Protection type	IP20
<b>Storage and transport conditions</b>	<b>X20DI6371</b>
Temperature	-25°C to +70°C
Relative humidity	5 to 95%, non-condensing
<b>Mechanical characteristics</b>	<b>X20DI6371</b>
Spacing	12.5 <sup>+0.2</sup> mm
Comment	Order terminal block 1x X20TB06 or X20TB12 separately Order bus module 1x X20BM11 separately

**The X20 6-pin terminal block can be used for universal 1-line wiring.  
Two-line wiring can be implemented using the 12-pin terminal block.**

### Pin assignments

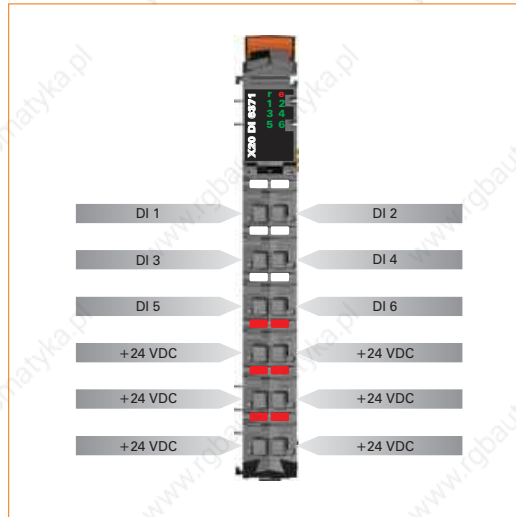

### Connection example

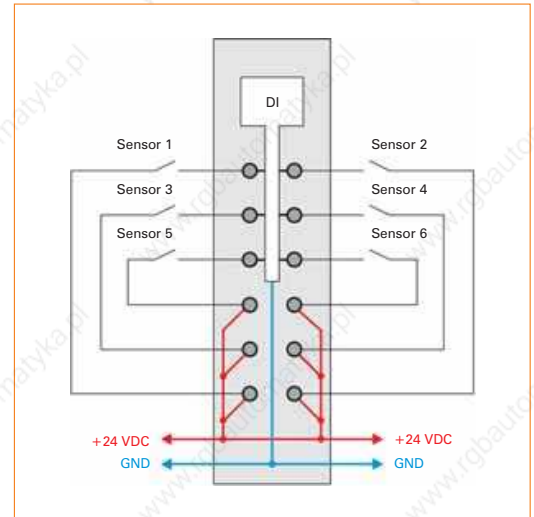

#### Required accessories

X20TB06	X20 terminal block, 6-pin, 24 V coded	▮ 94
X20TB12	X20 terminal block, 12-pin, 24 V coded	▮ 94
X20BM11	X20 bus module, 24 V coded, internal I/O supply is interconnected	▮ 88

## Digital input module DI6372



- 6 digital inputs
- source connection
- 2-wire connection
- 24 VDC for sensor supply
- Software input filter can be configured for the entire module
- 1-line connection with 6-pin terminal block

<b>Short description</b>	<b>X20DI6372</b>
I/O module	Six 24 VDC digital inputs for 1 or 2-wire connections
<b>Digital inputs</b>	<b>X20DI6372</b>
Rated voltage	24 VDC
Input filter	
Hardware	≤100 μs
Software	Default 1 ms, can be configured between 0 and 25 ms in 0.2 ms intervals
Connection type	1 or 2 line connection
Input circuit	Source
<b>General information</b>	<b>X20DI6372</b>
Status indicators	I/O function per channel, operating state, module status
Diagnostics	
Module run/error	Yes, with status LED and software status
Electrical isolation	
Channel - Bus	Yes
Channel - Channel	No
Power consumption	
Bus	0.15 W
I/O internal	0.88 W
Certification	CE, C-UL-US, GOST-R
<b>Operational conditions</b>	<b>X20DI6372</b>
Operating temperature	
Horizontal installation	0°C to +55°C
Vertical installation	0°C to +50°C
Relative humidity	5 to 95%, non-condensing
Mounting orientation	Horizontal or vertical
Installation at altitudes above sea level	
0 - 2000 m	No derating
>2000 m	Reduction of ambient temperature by 0.5°C per 100 m
Protection type	IP20
<b>Storage and transport conditions</b>	<b>X20DI6372</b>
Temperature	-25°C to +70°C
Relative humidity	5 to 95%, non-condensing
<b>Mechanical characteristics</b>	<b>X20DI6372</b>
Spacing	12.5 <sup>+0.2</sup> mm
Comment	Order terminal block 1x X20TB06 or X20TB12 separately Order bus module 1x X20BM11 separately

*The X20 6-pin terminal block can be used for universal 1-line wiring.  
Two-line wiring can be implemented using the 12-pin terminal block.*

## Pin assignments

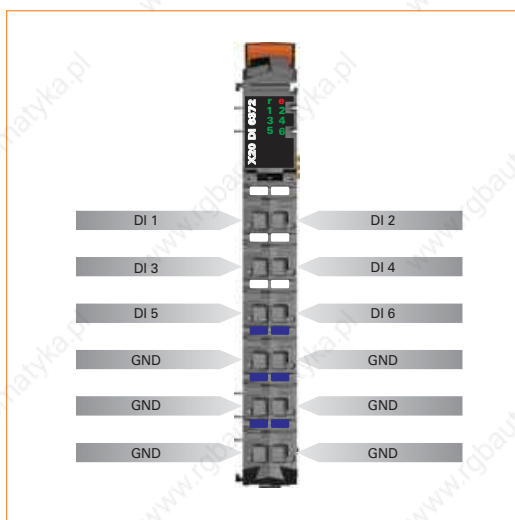

## Connection example

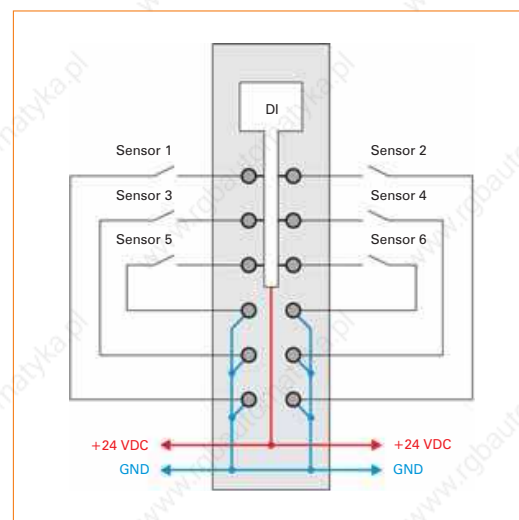

### Required accessories

X20TB06	X20 terminal block, 6-pin, 24 V coded	▯ 94
X20TB12	X20 terminal block, 12-pin, 24 V coded	▯ 94
X20BM11	X20 bus module, 24 V coded, internal I/O supply is interconnected	▯ 88

## Digital input module DI6553



- 6 digital inputs
- 120 VAC inputs
- 50 Hz or 60 Hz
- 1-wire connection
- Special color
- 240 V coded

<b>Short description</b>	<b>X20DI6553</b>
I/O module	6 digital inputs for 100 - 120 VAC, 1-line connections
<b>Digital inputs</b>	<b>X20DI6553</b>
Rated voltage	100 - 120 VAC
Rated frequency	47 - 63 Hz
Input filter	
Hardware	
0 → 1	≤15 ms
1 → 0	≤30 ms
Software	Default 1 ms, can be configured between 0 and 25 ms in 0.2 ms intervals
Connection type	1-line connections
<b>General information</b>	<b>X20DI6553</b>
Status indicators	I/O function per channel, operating state, module status
Diagnostics	
Module run/error	Yes, with status LED and software status
I/O external supply	Yes, with software status (typical threshold 85 VAC)
Electrical isolation	
Channel - Bus	Yes
Channel - Channel	No
Power consumption	
Bus	0.21 W
I/O internal	-
I/O external	0.68 W
Certification	CE, C-UL-US, GOST-R
<b>Operational conditions</b>	<b>X20DI6553</b>
Operating temperature	
Horizontal installation	0°C to +55°C
Vertical installation	0°C to +50°C
Relative humidity	5 to 95%, non-condensing
Mounting orientation	Horizontal or vertical
Installation at altitudes above sea level	
0 - 2000 m	No derating
>2000 m	Reduction of ambient temperature by 0.5°C per 100 m
Protection type	IP20
<b>Storage and transport conditions</b>	<b>X20DI6553</b>
Temperature	-25°C to +70°C
Relative humidity	5 to 95%, non-condensing
<b>Mechanical characteristics</b>	<b>X20DI6553</b>
Spacing	12.5 <sup>+0.2</sup> mm
Comment	Order terminal block 1x X20TB32 separately Order bus module 1x X20BM12 separately

### Pin assignments

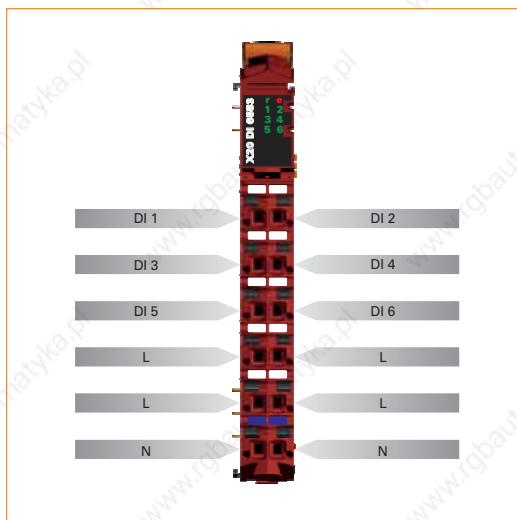

### Connection example

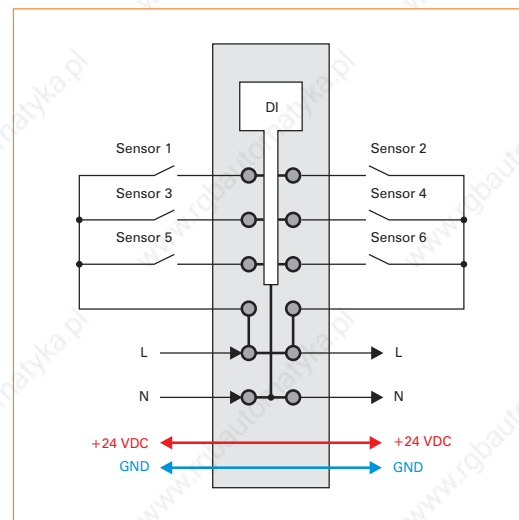

#### Required accessories

X20TB32	X20 terminal block, 12-pin, 240 V coded	95
X20BM12	X20 bus module, 240 V coded, internal I/O supply is interconnected	89

## Digital input module DI8371



- 8 digital inputs
- Sink connection
- 1-wire connection
- Software input filter can be configured for the entire module

<b>Short description</b>	<b>X20DI8371</b>
I/O module	Eight 24 VDC digital inputs for 1-line connections
<b>Digital inputs</b>	<b>X20DI8371</b>
Rated voltage	24 VDC
Input filter	
Hardware	≤100 μs
Software	Default 1 ms, can be configured between 0 and 25 ms in 0.2 ms intervals
Connection type	1-line connections
Input circuit	Sink
<b>General information</b>	<b>X20DI8371</b>
Status indicators	I/O function per channel, operating state, module status
Diagnostics	
Module run/error	Yes, with status LED and software status
Electrical isolation	
Channel - Bus	Yes
Channel - Channel	No
Power consumption	
Bus	0.18 W
I/O internal	-
I/O external	1.2 W
Certification	CE, C-UL-US (in development), GOST-R
<b>Operational conditions</b>	<b>X20DI8371</b>
Operating temperature	
Horizontal installation	0°C to +55°C
Vertical installation	0°C to +50°C
Relative humidity	5 to 95%, non-condensing
Mounting orientation	Horizontal or vertical
Installation at altitudes above sea level	
0 - 2000 m	No derating
>2000 m	Reduction of ambient temperature by 0.5°C per 100 m
Protection type	IP20
<b>Storage and transport conditions</b>	<b>X20DI8371</b>
Temperature	-25°C to +70°C
Relative humidity	5 to 95%, non-condensing
<b>Mechanical characteristics</b>	<b>X20DI8371</b>
Spacing	12.5 <sup>+0.2</sup> mm
Comment	Order terminal block 1x X20TB12 separately Order bus module 1x X20BM11 separately

## Pin assignments

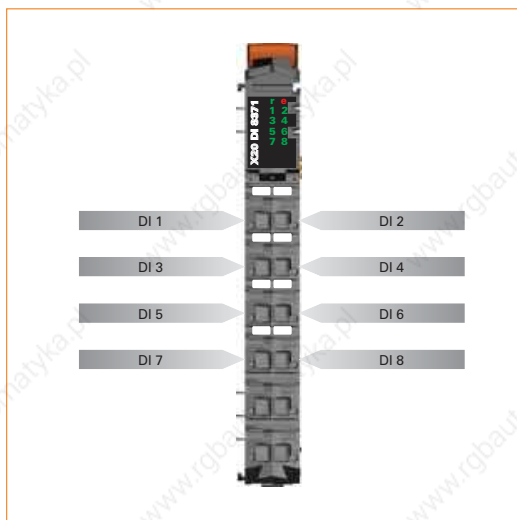

## Connection example

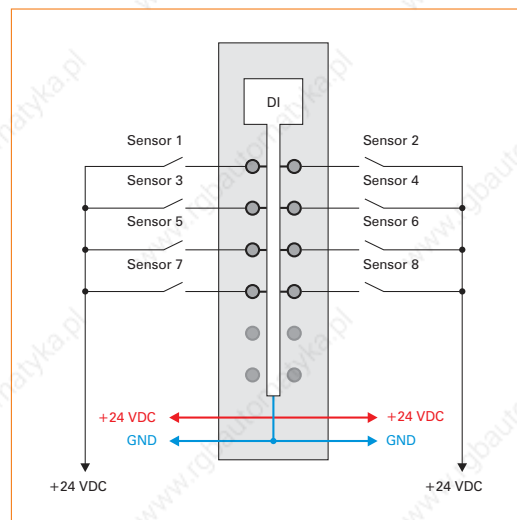

### Required accessories

X20TB12	X20 terminal block, 12-pin, 24 V coded	94
X20BM11	X20 bus module, 24 V coded, internal I/O supply is interconnected	88

## Digital input module DI9371



- 12 digital inputs
- Sink connection
- 1-wire connection
- Software input filter can be configured for the entire module

<b>Short description</b>	<b>X20DI9371</b>
I/O module	Twelve 24 VDC digital inputs for 1-wire connections
<b>Digital inputs</b>	<b>X20DI9371</b>
Rated voltage	24 VDC
Input filter	
Hardware	≤100 μs
Software	Default 1 ms, can be configured between 0 and 25 ms in 0.2 ms intervals
Connection type	1-line connections
Input circuit	Sink
Simultaneousness	
With 24 V I/O supply	100%
With 28.8 V I/O supply	75%
<b>General information</b>	<b>X20DI9371</b>
Status indicators	I/O function per channel, operating state, module status
Diagnosics	
Module run/error	Yes, with status LED and software status
Electrical isolation	
Channel - Bus	Yes
Channel - Channel	No
Power consumption	
Bus	0.18 W
I/O internal	–
I/O external	1.75 W
Certification	CE, C-UL-US, GOST-R
<b>Operational conditions</b>	<b>X20DI9371</b>
Operating temperature	
Horizontal installation	0°C to +55°C
Vertical installation	0°C to +50°C
Relative humidity	5 to 95%, non-condensing
Mounting orientation	Horizontal or vertical
Installation at altitudes above sea level	
0 - 2000 m	No derating
>2000 m	Reduction of ambient temperature by 0.5°C per 100 m
Protection type	IP20
<b>Storage and transport conditions</b>	<b>X20DI9371</b>
Temperature	-25°C to +70°C
Relative humidity	5 to 95%, non-condensing
<b>Mechanical characteristics</b>	<b>X20DI9371</b>
Spacing	12.5 <sup>+0.2</sup> mm
Comment	Order terminal block 1x X20TB12 separately Order bus module 1x X20BM11 separately

### Pin assignments

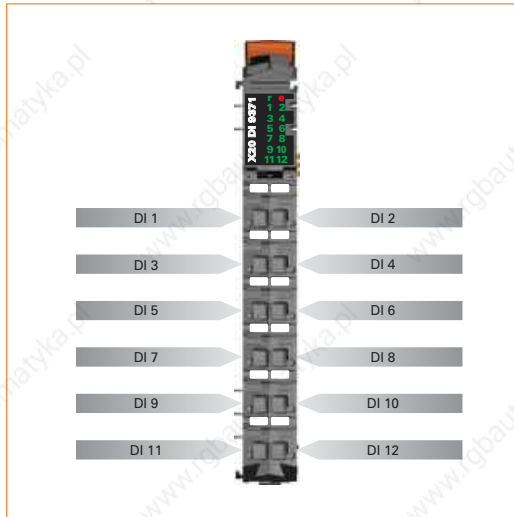

### Connection example

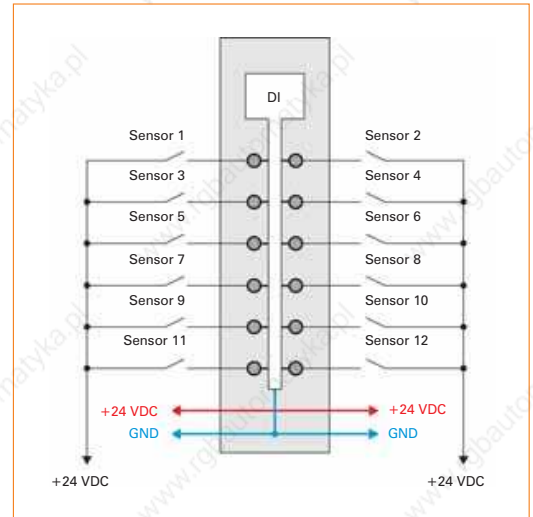

#### Required accessories

X20TB12	X20 terminal block, 12-pin, 24 V coded	94
X20BM11	X20 bus module, 24 V coded, internal I/O supply is interconnected	88

## Digital input module DI9372



- 12 digital inputs
- source connection
- 1-wire connection
- Software input filter can be configured for the entire module

<b>Short description</b>	<b>X20DI9372</b>
I/O module	Twelve 24 VDC digital inputs for 1-wire connections
<b>Digital inputs</b>	<b>X20DI9372</b>
Rated voltage	24 VDC
Input filter	
Hardware	≤100 μs
Software	Default 1 ms, can be configured between 0 and 25 ms in 0.2 ms intervals
Connection type	1-line connections
Input circuit	Source
Simultaneousness	
With 24 V I/O supply	100%
With 28.8 V I/O supply	75%
<b>General information</b>	<b>X20DI9372</b>
Status indicators	I/O function per channel, operating state, module status
Diagnosics	
Module run/error	Yes, with status LED and software status
Electrical isolation	
Channel - Bus	Yes
Channel - Channel	No
Power consumption	
Bus	0.18 W
I/O internal	1.75 W
Certification	CE, C-UL-US, GOST-R
<b>Operational conditions</b>	<b>X20DI9372</b>
Operating temperature	
Horizontal installation	0°C to +55°C
Vertical installation	0°C to +50°C
Relative humidity	5 to 95%, non-condensing
Mounting orientation	Horizontal or vertical
Installation at altitudes above sea level	
0 - 2000 m	No derating
>2000 m	Reduction of ambient temperature by 0.5°C per 100 m
Protection type	IP20
<b>Storage and transport conditions</b>	<b>X20DI9372</b>
Temperature	-25°C to +70°C
Relative humidity	5 to 95%, non-condensing
<b>Mechanical characteristics</b>	<b>X20DI9372</b>
Spacing	12.5 <sup>+0.2</sup> mm
Comment	Order terminal block 1x X20TB12 separately Order bus module 1x X20BM11 separately

### Pin assignments

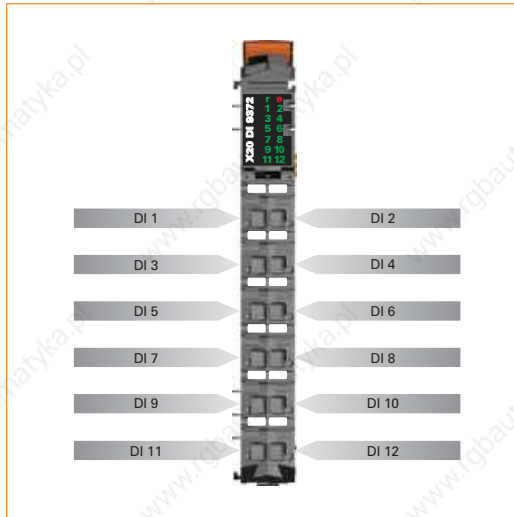

### Connection example

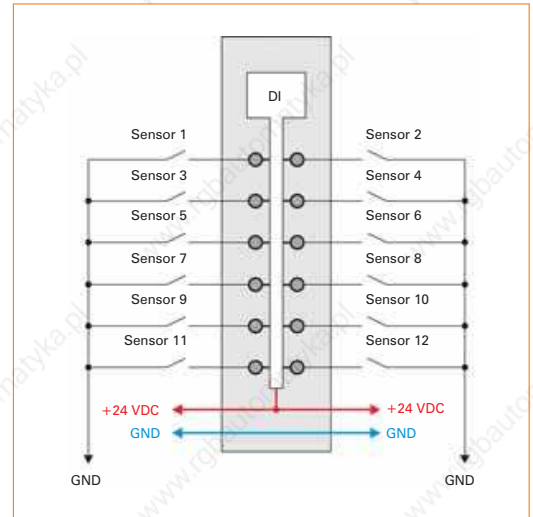

#### Required accessories

X20TB12	X20 terminal block, 12-pin, 24 V coded	94
X20BM11	X20 bus module, 24 V coded, internal I/O supply is interconnected	88

## Digital output module DO2321



- 2 digital outputs
- Sink connection
- 3-wire connection
- 24 VDC and GND for actuator supply
- Integrated output protection

<b>Short description</b>	<b>X20DO2321</b>
I/O module	Two 24 VDC digital outputs for 3-line connections
<b>Digital outputs</b>	<b>X20DO2321</b>
Rated voltage	24 VDC
Rated output current	0.5 A
Total current	1.0 A
Connection type	3-line connections
Output circuit	Sink
Output protection	Thermal cutoff for overcurrent and short circuit, integrated protection for switching inductances
Actuator supply	0.5 A in total for output-independent actuator supply
<b>General information</b>	<b>X20DO2321</b>
Status indicators	I/O function per channel, operating state, module status
Diagnostics	
Module run/error	Yes, with status LED and software status
Outputs	Yes, with status LED and software status (output error status)
Electrical isolation	
Channel - Bus	Yes
Channel - Channel	No
Power consumption	
Bus	0.13 W
I/O internal	0.3 W
Certification	CE, C-UL-US, GOST-R
<b>Operational conditions</b>	<b>X20DO2321</b>
Operating temperature	
Horizontal installation	0°C to +55°C
Vertical installation	0°C to +50°C
Relative humidity	5 to 95%, non-condensing
Mounting orientation	Horizontal or vertical
Installation at altitudes above sea level	
0 - 2000 m	No derating
>2000 m	Reduction of ambient temperature by 0.5°C per 100 m
Protection type	IP20
<b>Storage and transport conditions</b>	<b>X20DO2321</b>
Temperature	-25°C to +70°C
Relative humidity	5 to 95%, non-condensing
<b>Mechanical characteristics</b>	<b>X20DO2321</b>
Spacing	12.5 <sup>+0.2</sup> mm
Comment	Order terminal block 1x X20TB06 or X20TB12 separately Order bus module 1x X20BM11 separately

*The module is designed for X20 6-pin terminal blocks. However, the 12-pin terminal block can also be used.*

### Pin assignments



### Connection example

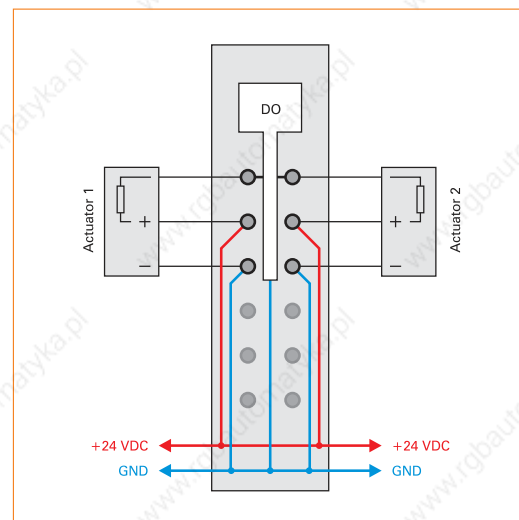

#### Required accessories

X20TB06	X20 terminal block, 6-pin, 24 V coded	94
X20TB12	X20 terminal block, 12-pin, 24 V coded	94
X20BM11	X20 bus module, 24 V coded, internal I/O supply is interconnected	88

## Digital output module DO2322



- 2 digital outputs
- source connection
- 3-wire connection
- 24 VDC and GND for actuator supply
- Integrated output protection

<b>Short description</b>	<b>X20DO2322</b>
I/O module	Two 24 VDC digital outputs for 3-line connections
<b>Digital outputs</b>	<b>X20DO2322</b>
Rated voltage	24 VDC
Rated output current	0.5 A
Total current	1.0 A
Connection type	3-line connections
Output circuit	Source
Output protection	Thermal cutoff for overcurrent and short circuit, integrated protection for switching inductances
Actuator supply	0.5 A in total for output-independent actuator supply
<b>General information</b>	<b>X20DO2322</b>
Status indicators	I/O function per channel, operating state, module status
Diagnostics	
Module run/error	Yes, with status LED and software status
Outputs	Yes, with status LED and software status (output error status)
Electrical isolation	
Channel - Bus	Yes
Channel - Channel	No
Power consumption	
Bus	0.13 W
I/O internal	0.33 W
Certification	CE, C-UL-US, GOST-R, BG-PRÜFZERT <sup>1)</sup>
<small>1) Operating principle checked: Shutdown initiated by external safety switching device</small>	
<b>Operational conditions</b>	<b>X20DO2322</b>
Operating temperature	
Horizontal installation	0°C to +55°C
Vertical installation	0°C to +50°C
Relative humidity	5 to 95%, non-condensing
Mounting orientation	Horizontal or vertical
Installation at altitudes above sea level	
0 - 2000 m	No derating
>2000 m	Reduction of ambient temperature by 0.5°C per 100 m
Protection type	IP20
<b>Storage and transport conditions</b>	<b>X20DO2322</b>
Temperature	-25°C to +70°C
Relative humidity	5 to 95%, non-condensing
<b>Mechanical characteristics</b>	<b>X20DO2322</b>
Spacing	12.5 <sup>+0.2</sup> mm
Comment	Order terminal block 1x X20TB06 or X20TB12 separately Order bus module 1x X20BM11 separately

*The module is designed for X20 6-pin terminal blocks. However, the 12-pin terminal block can also be used.*

### Pin assignments



### Connection example

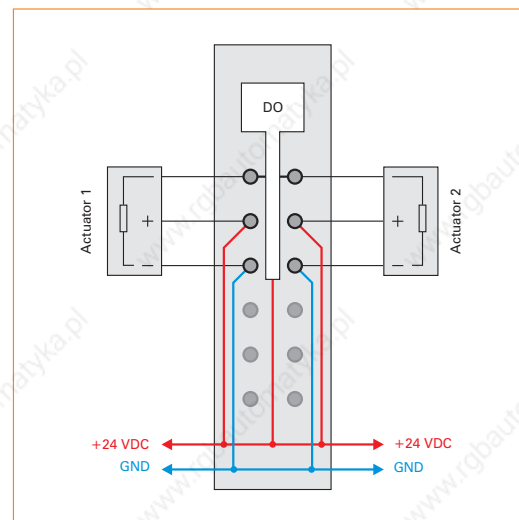

#### Required accessories

X20TB06	X20 terminal block, 6-pin, 24 V coded	94
X20TB12	X20 terminal block, 12-pin, 24 V coded	94
X20BM11	X20 bus module, 24 V coded, internal I/O supply is interconnected	88

## Digital output module DO2623



- 2 digital outputs
- Outputs with integrated snubber circuit
- Outputs with 100 - 240 VAC
- L switching
- 50 Hz or 60 Hz
- 3-wire connection
- Integrated full-wave control
- Special color
- 240 V coding

<b>Short description</b>	<b>X20DO2623</b>
I/O module	2 digital SSR outputs 100 - 240 VAC, 3-line connections
<b>Digital outputs</b>	<b>X20DO2623</b>
Design	SSR
Wiring	L switching
Rated voltage	100 - 240 VAC
Rated frequency	47 to 63 Hz
Rated output current	1.0 A
Total current	1.0 A
Surge current	40 A (20 ms), 10 A (1 s)
Connection type	3-line connections
Zero cross-over switches	Yes
<b>General information</b>	<b>X20DO2623</b>
Status indicators	I/O function per channel, operating state, module status
Diagnosics	
Module run/error	Yes, with status LED and software status
Outputs	Yes, with status LED
Electrical isolation	
Channel - Bus	Yes
Channel - Channel	No
Power consumption	
Bus	0.35 W
I/O internal	-
I/O external	0.38 W
Certification	CE, C-UL-US, GOST-R
<b>Operational conditions</b>	<b>X20DO2623</b>
Operating temperature	
Horizontal installation	0°C to +55°C
Vertical installation	0°C to +50°C
Relative humidity	5 to 95%, non-condensing
Mounting orientation	Horizontal or vertical
Installation at altitudes above sea level	
0 - 2000 m	No derating
>2000 m	Reduction of ambient temperature by 0.5°C per 100 m
Protection type	IP20
<b>Storage and transport conditions</b>	<b>X20DO2623</b>
Temperature	-25°C to +70°C
Relative humidity	5 to 95%, non-condensing
<b>Mechanical characteristics</b>	<b>X20DO2623</b>
Spacing	12.5 <sup>+0.2</sup> mm
Comment	Order terminal block 1x X20TB32 separately Order bus module 1x X20BM12 separately

### Pin assignments

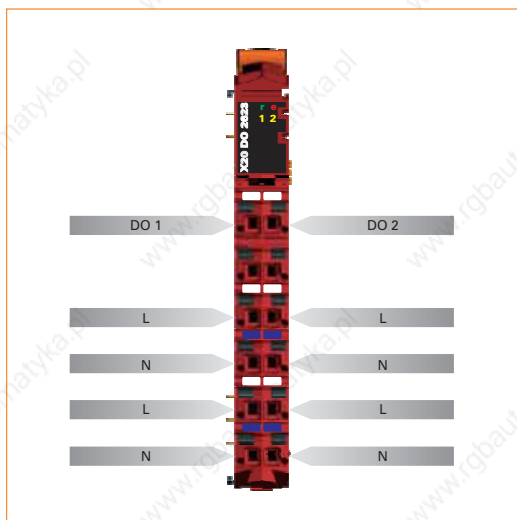

### Connection example

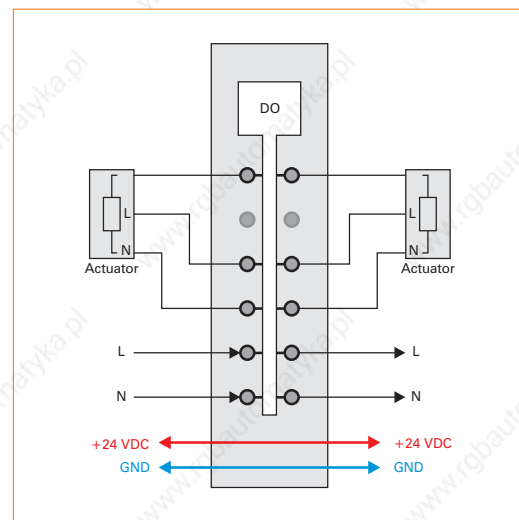

#### Required accessories

X20TB32	X20 terminal block, 12-pin, 240 V coded	95
X20BM12	X20 bus module, 240 V coded, internal I/O supply is interconnected	89

## Digital output module DO2649



- 2 digital outputs
- Relay module for 230 VAC
- 2 change over contacts
- Outputs single channel isolated

<b>Short description</b>	<b>X20DO2649</b>
I/O module	2 digital outputs 30 VDC / 230 VAC, outputs are single-channel isolated
<b>Digital outputs</b>	<b>X20DO2649</b>
Design	Relay / Change-over
	Channels are single-channel isolated
Rated voltage	30 VDC / 230 VAC
Rated frequency	DC / 45 to 63 Hz
Rated output current	5.0 A at 30 VDC / 5.0 A at 230 VAC
Total current	10.0 A at 30 VDC / 10.0 A at 115 VAC
Switching capacity	
Minimum	10 mA / 5 VDC
Maximum	180 W / 1500 VA
Actuator supply	External
<b>General information</b>	<b>X20DO2649</b>
Status indicators	I/O function per channel, operating state, module status
Diagnostics	
Module run/error	Yes, with status LED and software status
Outputs	Yes, with status LED
Electrical isolation	
Channel - Bus	Yes
Channel - Channel	Yes
Power consumption	
Bus	0.45 W
I/O internal	-
Certification	CE, C-UL-US, GOST-R
<b>Operational conditions</b>	<b>X20DO2649</b>
Operating temperature	
Horizontal installation	0°C to +55°C
Vertical installation	0°C to +50°C
Relative humidity	5 to 95%, non-condensing
Mounting orientation	Horizontal or vertical
Installation at altitudes above sea level	
0 - 2000 m	No derating
>2000 m	Reduction of ambient temperature by 0.5°C per 100 m
Protection type	IP20
<b>Storage and transport conditions</b>	<b>X20DO2649</b>
Temperature	-25°C to +70°C
Relative humidity	5 to 95%, non-condensing
<b>Mechanical characteristics</b>	<b>X20DO2649</b>
Spacing	12.5 <sup>+0.2</sup> mm
Comment	Order terminal block 1x X20TB12 separately Order bus module 1x X20BM11 separately

### Pin assignments



### Connection example

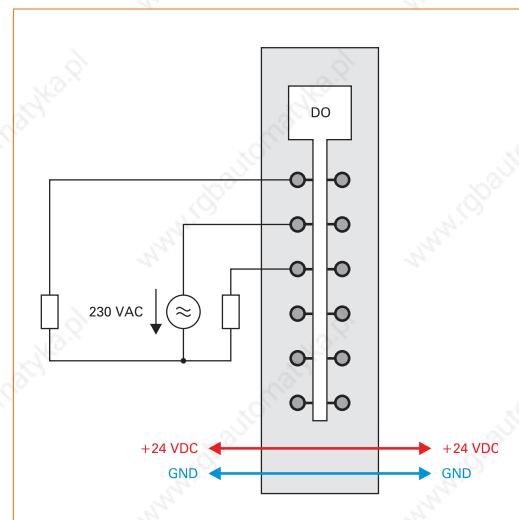

#### Required accessories

X20TB12	X20 terminal block, 12-pin, 24 V coded	94
X20BM11	X20 bus module, 24 V coded, internal I/O supply is interconnected	88

## Digital output module DO4321



- 4 digital outputs
- Sink connection
- 3-wire connection
- 24 VDC and GND for actuator supply
- Integrated output protection

<b>Short description</b>	<b>X20DO4321</b>
I/O module	Four 24 VDC digital outputs for 3-line connections
<b>Digital outputs</b>	<b>X20DO4321</b>
Rated voltage	24 VDC
Rated output current	0.5 A
Total current	2.0 A
Connection type	3-line connections
Output circuit	Sink
Output protection	Thermal cutoff for overcurrent and short circuit, integrated protection for switching inductances
Actuator supply	0.5 A in total for output-independent actuator supply
<b>General information</b>	<b>X20DO4321</b>
Status indicators	I/O function per channel, operating state, module status
Diagnostics	
Module run/error	Yes, with status LED and software status
Outputs	Yes, with status LED and software status (output error status)
Electrical isolation	
Channel - Bus	Yes
Channel - Channel	No
Power consumption	
Bus	0.16 W
I/O internal	0.49 W
Certification	CE, C-UL-US, GOST-R
<b>Operational conditions</b>	<b>X20DO4321</b>
Operating temperature	
Horizontal installation	0°C to +55°C
Vertical installation	0°C to +50°C
Relative humidity	5 to 95%, non-condensing
Mounting orientation	Horizontal or vertical
Installation at altitudes above sea level	
0 - 2000 m	No derating
>2000 m	Reduction of ambient temperature by 0.5°C per 100 m
Protection type	IP20
<b>Storage and transport conditions</b>	<b>X20DO4321</b>
Temperature	-25°C to +70°C
Relative humidity	5 to 95%, non-condensing
<b>Mechanical characteristics</b>	<b>X20DO4321</b>
Spacing	12.5 <sup>+0.2</sup> mm
Comment	Order terminal block 1x X20TB12 separately Order bus module 1x X20BM11 separately

### Pin assignments

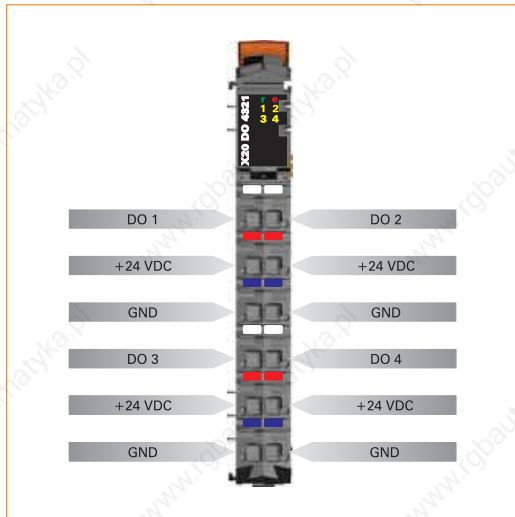

### Connection example

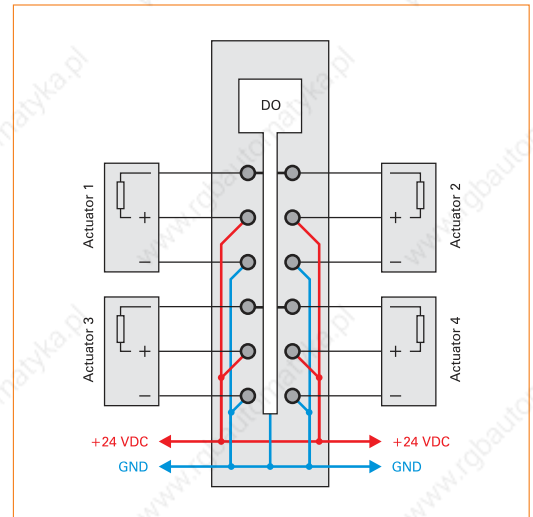

#### Required accessories

X20TB12	X20 terminal block, 12-pin, 24 V coded	▣ 94
X20BM11	X20 bus module, 24 V coded, internal I/O supply is interconnected	▣ 88

## Digital output module DO4322



- 4 digital outputs
- source connection
- 3-wire connection
- 24 VDC and GND for actuator supply
- Integrated output protection

<b>Short description</b>	<b>X20DO4322</b>
I/O module	Four 24 VDC digital outputs for 3-line connections
<b>Digital outputs</b>	<b>X20DO4322</b>
Rated voltage	24 VDC
Rated output current	0.5 A
Total current	2.0 A
Connection type	3-line connections
Output circuit	Source
Output protection	Thermal cutoff for overcurrent and short circuit, integrated protection for switching inductances
Actuator supply	0.5 A in total for output-independent actuator supply
<b>General information</b>	<b>X20DO4322</b>
Status indicators	I/O function per channel, operating state, module status
Diagnostics	
Module run/error	Yes, with status LED and software status
Outputs	Yes, with status LED and software status (output error status)
Electrical isolation	
Channel - Bus	Yes
Channel - Channel	No
Power consumption	
Bus	0.16 W
I/O internal	0.49 W
Certification	CE, C-UL-US, GOST-R, BG-PRÜFZERT <sup>1)</sup>
<small>1) Operating principle checked: Shutdown initiated by external safety switching device</small>	
<b>Operational conditions</b>	<b>X20DO4322</b>
Operating temperature	
Horizontal installation	0°C to +55°C
Vertical installation	0°C to +50°C
Relative humidity	5 to 95%, non-condensing
Mounting orientation	Horizontal or vertical
Installation at altitudes above sea level	
0 - 2000 m	No derating
>2000 m	Reduction of ambient temperature by 0.5°C per 100 m
Protection type	IP20
<b>Storage and transport conditions</b>	<b>X20DO4322</b>
Temperature	-25°C to +70°C
Relative humidity	5 to 95%, non-condensing
<b>Mechanical characteristics</b>	<b>X20DO4322</b>
Spacing	12.5 <sup>+0.2</sup> mm
Comment	Order terminal block 1x X20TB12 separately Order bus module 1x X20BM11 separately

### Pin assignments

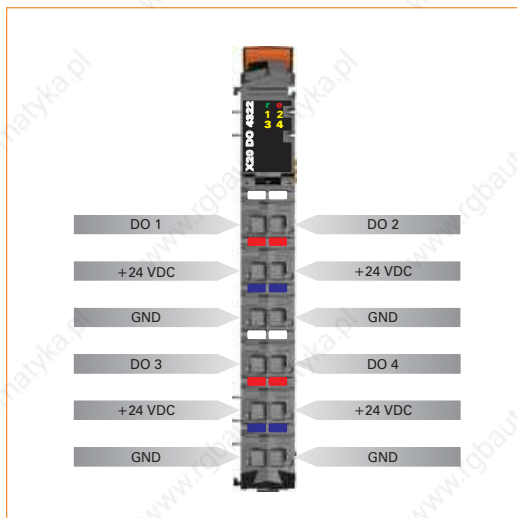

### Connection example

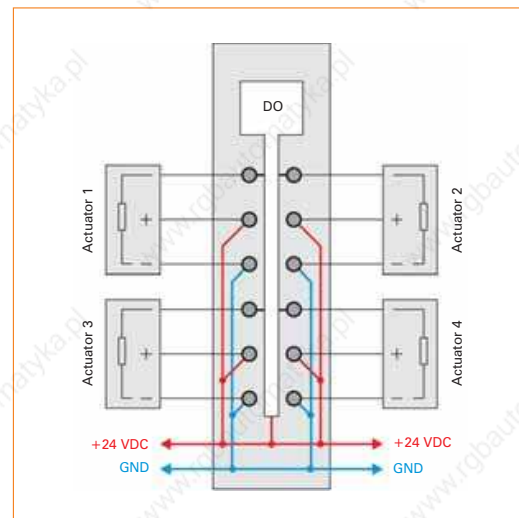

#### Required accessories

X20TB12	X20 terminal block, 12-pin, 24 V coded	94
X20BM11	X20 bus module, 24 V coded, internal I/O supply is interconnected	88

## Digital output module DO4331



- 4 digital outputs with 2 A
- Sink connection
- 3-wire connection
- 24 VDC and GND for actuator supply
- Integrated output protection

<b>Short description</b>	<b>X20DO4331</b>
I/O module	Four 24 VDC digital outputs for 3-line connections
<b>Digital outputs</b>	<b>X20DO4331</b>
Rated voltage	24 VDC
Rated output current	2.0 A
Total current	8.0 A
Connection type	3-line connections
Output circuit	Sink
Output protection	Thermal cutoff for overcurrent and short circuit, integrated protection for switching inductances
Additional functions for outputs	To increase the output current, outputs can be switched in parallel
Actuator supply	0.5 A in total for output-independent actuator supply
<b>General information</b>	<b>X20DO4331</b>
Status indicators	I/O function per channel, operating state, module status
<b>Diagnostics</b>	
Module run/error	Yes, with status LED and software status
Outputs	Yes, with status LED and software status (output error status)
<b>Electrical isolation</b>	
Channel - Bus	Yes
Channel - Channel	No
<b>Power consumption</b>	
Bus	0.16 W
I/O internal	0.49 W
Certification	CE, C-UL-US, GOST-R
<b>Operational conditions</b>	<b>X20DO4331</b>
<b>Operating temperature</b>	
Horizontal installation	0°C to +55°C
Vertical installation	0°C to +50°C
Relative humidity	5 to 95%, non-condensing
Mounting orientation	Horizontal or vertical
<b>Installation at altitudes above sea level</b>	
0 - 2000 m	No derating
>2000 m	Reduction of ambient temperature by 0.5°C per 100 m
Protection type	IP20
<b>Storage and transport conditions</b>	<b>X20DO4331</b>
Temperature	-25°C to +70°C
Relative humidity	5 to 95%, non-condensing
<b>Mechanical characteristics</b>	<b>X20DO4331</b>
Spacing	12.5 <sup>+0.2</sup> mm
Comment	Order terminal block 1x X20TB12 separately Order bus module 1x X20BM11 separately

### Pin assignments

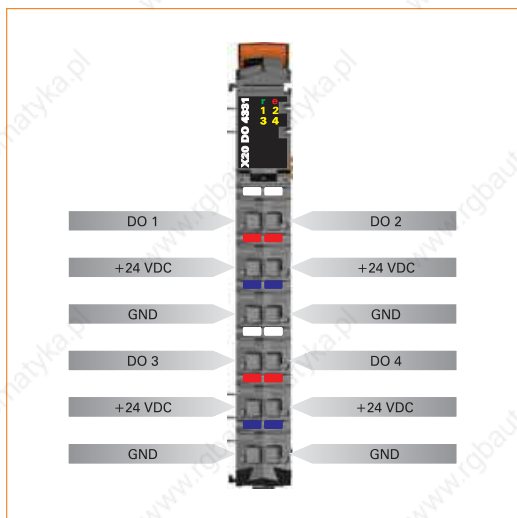

### Connection example

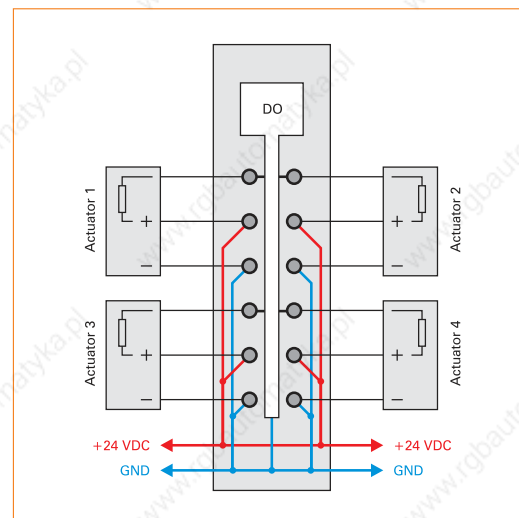

#### Required accessories

X20TB12	X20 terminal block, 12-pin, 24 V coded	94
X20BM11	X20 bus module, 24 V coded, internal I/O supply is interconnected	88

## Digital output module DO4332



- 4 digital outputs with 2 A
- source connection
- 3-wire connection
- 24 VDC and GND for actuator supply
- Integrated output protection

<b>Short description</b>	<b>X20DO4332</b>
I/O module	Four 24 VDC digital outputs for 3-line connections
<b>Digital outputs</b>	<b>X20DO4332</b>
Rated voltage	24 VDC
Rated output current	2.0 A
Total current	4.0 A
Connection type	3-line connections
Output circuit	Source
Output protection	Thermal cutoff for overcurrent and short circuit, integrated protection for switching inductances
Additional functions for outputs	To increase the output current, outputs can be switched in parallel
Actuator supply	0.5 A in total for output-independent actuator supply
<b>General information</b>	<b>X20DO4332</b>
Status indicators	I/O function per channel, operating state, module status
<b>Diagnostics</b>	
Module run/error	Yes, with status LED and software status
Outputs	Yes, with status LED and software status (output error status)
<b>Electrical isolation</b>	
Channel - Bus	Yes
Channel - Channel	No
<b>Power consumption</b>	
Bus	0.16 W
I/O internal	0.5 W
Certification	CE, C-UL-US, GOST-R, BG-PRÜFZERT <sup>1)</sup>
<small>1) Operating principle checked: Shutdown initiated by external safety switching device</small>	
<b>Operational conditions</b>	<b>X20DO4332</b>
<b>Operating temperature</b>	
Horizontal installation	0°C to +55°C
Vertical installation	0°C to +50°C
Relative humidity	5 to 95%, non-condensing
Mounting orientation	Horizontal or vertical
Installation at altitudes above sea level	
0 - 2000 m	No derating
>2000 m	Reduction of ambient temperature by 0.5°C per 100 m
Protection type	IP20
<b>Storage and transport conditions</b>	<b>X20DO4332</b>
Temperature	-25°C to +70°C
Relative humidity	5 to 95%, non-condensing
<b>Mechanical characteristics</b>	<b>X20DO4332</b>
Spacing	12.5 <sup>+0.2</sup> mm
Comment	Order terminal block 1x X20TB12 separately Order bus module 1x X20BM11 separately

### Pin assignments

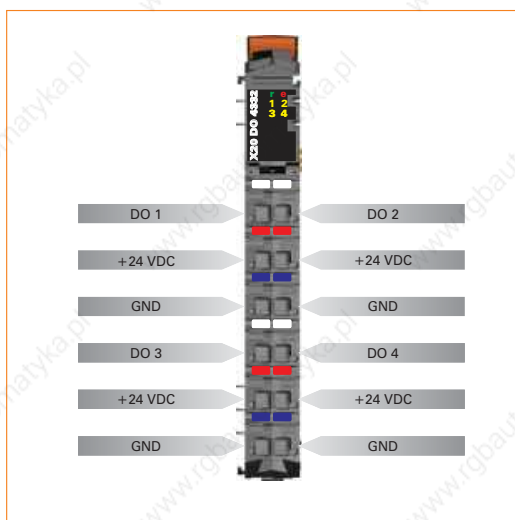

### Connection example

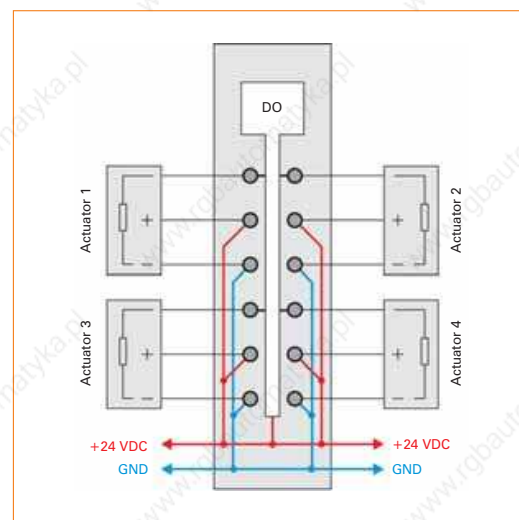

#### Required accessories

X20TB12	X20 terminal block, 12-pin, 24 V coded	94
X20BM11	X20 bus module, 24 V coded, internal I/O supply is interconnected	88

## Digital output module DO4529



- 4 digital outputs
- Relay module for 115 VAC
- 4 change over contacts
- Outputs single channel isolated

<b>Short description</b>	<b>X20DO4529</b>
I/O module	4 digital outputs 30 VDC / 115 VAC, outputs are single-channel isolated
<b>Digital outputs</b>	<b>X20DO4529</b>
Design	Relay / Change-over Channels are single-channel isolated
Rated voltage	30 VDC / 115 VAC
Rated frequency	DC / 45 to 63 Hz
Rated output current	1.0 A at 30 VDC / 0.5 A at 115 VAC
Total current	4.0 A at 30 VDC / 2.0 A at 115 VAC
Switching capacity	
Minimum	0.01 mA / 10 mV DC
Maximum	30 W / 62.5 VA
Actuator supply	External
<b>General information</b>	<b>X20DO4529</b>
Status indicators	I/O function per channel, operating state, module status
Diagnostics	
Module run/error	Yes, with status LED and software status
Outputs	Yes, with status LED
Electrical isolation	
Channel - Bus	Yes
Channel - Channel	Yes
Power consumption	
Bus	0.8 W
I/O internal	-
Certification	CE, C-UL-US, GOST-R
<b>Operational conditions</b>	<b>X20DO4529</b>
Operating temperature	
Horizontal installation	0°C to +55°C
Vertical installation	0°C to +50°C
Relative humidity	5 to 95%, non-condensing
Mounting orientation	Horizontal or vertical
Installation at altitudes above sea level	
0 - 2000 m	No derating
>2000 m	Reduction of ambient temperature by 0.5°C per 100 m
Protection type	IP20
<b>Storage and transport conditions</b>	<b>X20DO4529</b>
Temperature	-25°C to +70°C
Relative humidity	5 to 95%, non-condensing
<b>Mechanical characteristics</b>	<b>X20DO4529</b>
Spacing	12.5 <sup>+0.2</sup> mm
Comment	Order terminal block 1x X20TB12 separately Order bus module 1x X20BM11 separately

### Pin assignments

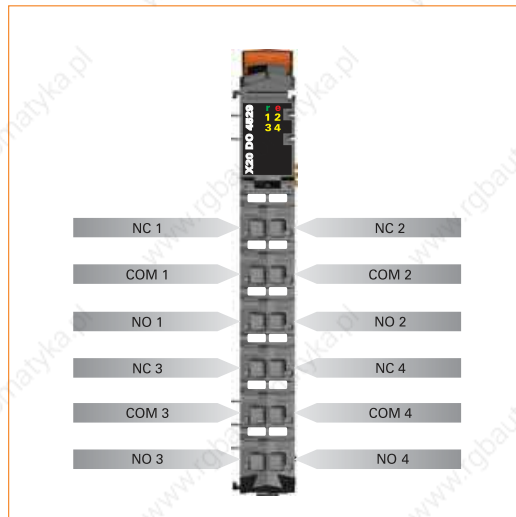

### Connection example

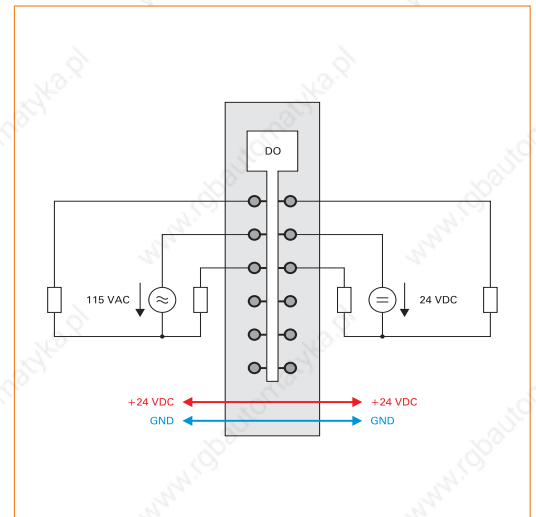

#### Required accessories

X20TB12	X20 terminal block, 12-pin, 24 V coded	94
X20BM11	X20 bus module, 24 V coded, internal I/O supply is interconnected	88

## Digital output module DO4623



- 4 digital outputs
- Outputs with integrated snubber circuit
- Outputs with 100 - 240 VAC
- L switching
- 50 Hz or 60 Hz
- 2-wire connection
- Integrated full-wave control
- Special color
- 240 V coding

<b>Short description</b>	<b>X20DO4623</b>
I/O module	4 digital SSR outputs 100 - 240 VAC, 2-line connections
<b>Digital outputs</b>	<b>X20DO4623</b>
Design	SSR
Wiring	L switching
Rated voltage	100 - 240 VAC
Rated frequency	47 to 63 Hz
Rated output current	0.5 A
Total current	1.0 A
Surge current	7 A (20 ms), 2 A (1 s)
Connection type	2-line connections
Zero cross-over switches	Yes
<b>General information</b>	<b>X20DO4623</b>
Status indicators	I/O function per channel, operating state, module status
Diagnostics	
Module run/error	Yes, with status LED and software status
Outputs	Yes, with status LED
Electrical isolation	
Channel - Bus	Yes
Channel - Channel	No
Power consumption	
Bus	0.52 W
I/O internal	-
I/O external	0.38 W
Certification	CE, C-UL-US, GOST-R
<b>Operational conditions</b>	<b>X20DO4623</b>
Operating temperature	
Horizontal installation	0°C to +55°C
Vertical installation	0°C to +50°C
Relative humidity	5 to 95%, non-condensing
Mounting orientation	Horizontal or vertical
Installation at altitudes above sea level	
0 - 2000 m	No derating
>2000 m	Reduction of ambient temperature by 0.5°C per 100 m
Protection type	IP20
<b>Storage and transport conditions</b>	<b>X20DO4623</b>
Temperature	-25°C to +70°C
Relative humidity	5 to 95%, non-condensing
<b>Mechanical characteristics</b>	<b>X20DO4623</b>
Spacing	12.5 <sup>+0.2</sup> mm
Comment	Order terminal block 1x X20TB32 separately Order bus module 1x X20BM12 separately

### Pin assignments

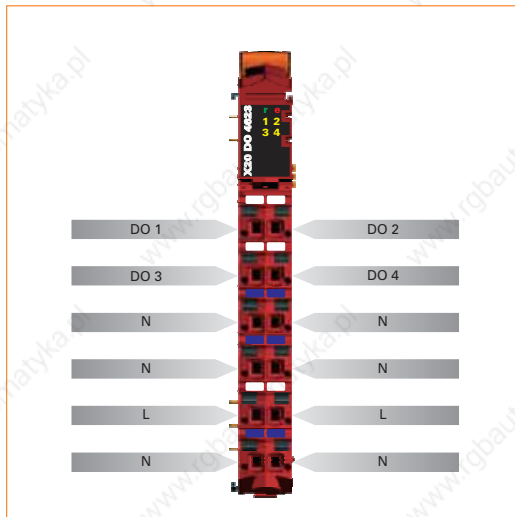

### Connection example

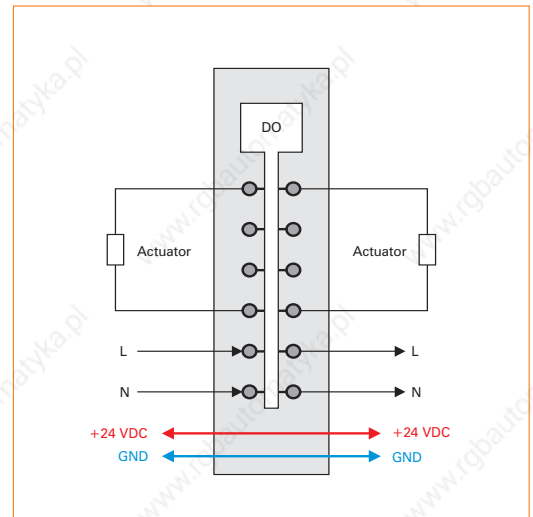

Required accessories		
X20TB32	X20 terminal block, 12-pin, 240 V coded	95
X20BM12	X20 bus module, 240 V coded, internal I/O supply is interconnected	89

## Digital output module DO6321



- 6 digital outputs
- Sink connection
- 2-wire connection
- 24 VDC for signal supply
- Integrated output protection
- 1-line connection with 6-pin terminal block

<b>Short description</b>	<b>X20DO6321</b>
I/O module	Six 24 VDC digital outputs for 1 or 2-wire connections
<b>Digital outputs</b>	<b>X20DO6321</b>
Rated voltage	24 VDC
Rated output current	0.5 A
Total current	3.0 A
Connection type	1 or 2 line connection
Output circuit	Sink
Output protection	Thermal cutoff for overcurrent and short circuit, integrated protection for switching inductances
<b>General information</b>	<b>X20DO6321</b>
Status indicators	I/O function per channel, operating state, module status
<b>Diagnostics</b>	
Module run/error	Yes, with status LED and software status
Outputs	Yes, with status LED and software status (output error status)
<b>Electrical isolation</b>	
Channel - Bus	Yes
Channel - Channel	No
<b>Power consumption</b>	
Bus	0.2 W
I/O internal	0.59 W
Certification	CE, C-UL-US, GOST-R, BG-PRÜFZERT <sup>1)</sup>
1) Operating principle checked: Shutdown initiated by external safety switching device	
<b>Operational conditions</b>	<b>X20DO6321</b>
<b>Operating temperature</b>	
Horizontal installation	0°C to +55°C
Vertical installation	0°C to +50°C
Relative humidity	5 to 95%, non-condensing
Mounting orientation	Horizontal or vertical
<b>Installation at altitudes above sea level</b>	
0 - 2000 m	No derating
>2000 m	Reduction of ambient temperature by 0.5°C per 100 m
Protection type	IP20
<b>Storage and transport conditions</b>	<b>X20DO6321</b>
Temperature	-25°C to +70°C
Relative humidity	5 to 95%, non-condensing
<b>Mechanical characteristics</b>	<b>X20DO6321</b>
Spacing	12.5 <sup>+0.2</sup> mm
Comment	Order terminal block 1x X20TB06 or X20TB12 separately Order bus module 1x X20BM11 separately

*The X20 6-pin terminal block can be used for universal 1-line wiring.  
Two-line wiring can be implemented using the 12-pin terminal block.*

## Pin assignments

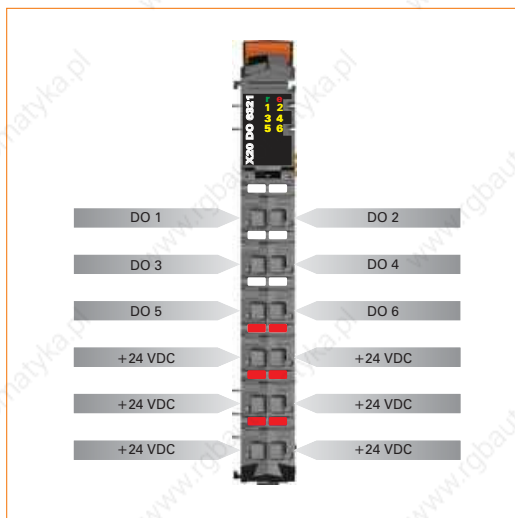

## Connection example

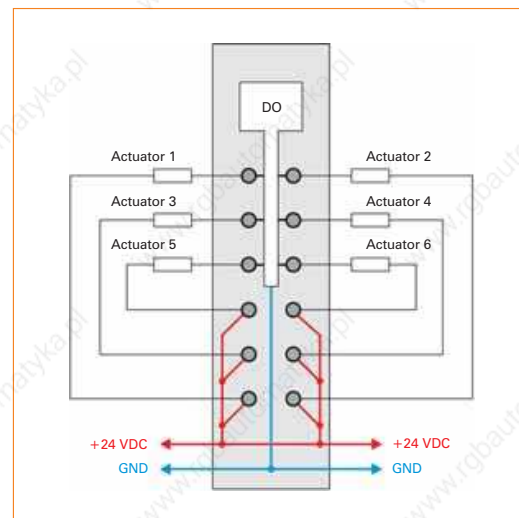

### Required accessories

X20TB06	X20 terminal block, 6-pin, 24 V coded	94
X20TB12	X20 terminal block, 12-pin, 24 V coded	94
X20BM11	X20 bus module, 24 V coded, internal I/O supply is interconnected	88

## Digital output module DO6322



- 6 digital outputs
- Source connection
- 2-wire connection
- GND for signal supply
- Integrated output protection
- 1-line connection with 6-pin terminal block

<b>Short description</b>	<b>X20DO6322</b>
I/O module	Six 24 VDC digital outputs for 1 or 2-wire connections
<b>Digital outputs</b>	<b>X20DO6322</b>
Rated voltage	24 VDC
Rated output current	0.5 A
Total current	3.0 A
Connection type	1 or 2 line connection
Output circuit	Source
Output protection	Thermal cutoff for overcurrent and short circuit, integrated protection for switching inductances
<b>General information</b>	<b>X20DO6322</b>
Status indicators	I/O function per channel, operating state, module status
<b>Diagnostics</b>	
Module run/error	Yes, with status LED and software status
Outputs	Yes, with status LED and software status (output error status)
<b>Electrical isolation</b>	
Channel - Bus	Yes
Channel - Channel	No
<b>Power consumption</b>	
Bus	0.18 W
I/O internal	0.71 W
Certification	CE, C-UL-US, GOST-R, BG-PRÜFZERT <sup>1)</sup>
1) Operating principle checked: Shutdown initiated by external safety switching device	
<b>Operational conditions</b>	<b>X20DO6322</b>
<b>Operating temperature</b>	
Horizontal installation	0°C to +55°C
Vertical installation	0°C to +50°C
<b>Relative humidity</b>	5 to 95%, non-condensing
<b>Mounting orientation</b>	Horizontal or vertical
<b>Installation at altitudes above sea level</b>	
0 - 2000 m	No derating
>2000 m	Reduction of ambient temperature by 0.5°C per 100 m
<b>Protection type</b>	IP20
<b>Storage and transport conditions</b>	<b>X20DO6322</b>
Temperature	-25°C to +70°C
Relative humidity	5 to 95%, non-condensing
<b>Mechanical characteristics</b>	<b>X20DO6322</b>
Spacing	12.5 <sup>+0.2</sup> mm
<b>Comment</b>	Order terminal block 1x X20TB06 or X20TB12 separately Order bus module 1x X20BM11 separately

*The X20 6-pin terminal block can be used for universal 1-line wiring.  
Two-line wiring can be implemented using the 12-pin terminal block.*

### Pin assignments

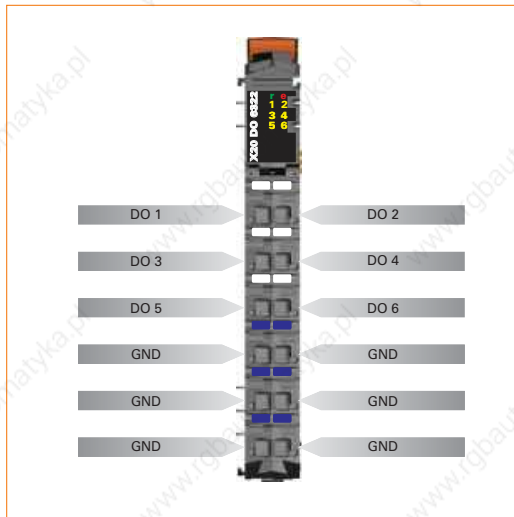

### Connection example

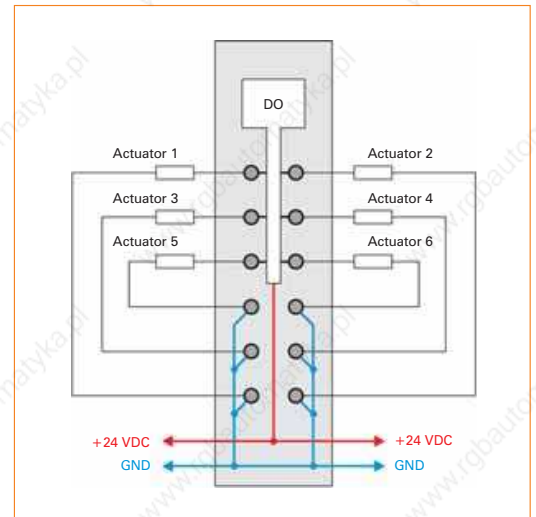

Required accessories		
X20TB06	X20 terminal block, 6-pin, 24 V coded	94
X20TB12	X20 terminal block, 12-pin, 24 V coded	94
X20BM11	X20 bus module, 24 V coded, internal I/O supply is interconnected	88

## Digital output module DO6529



- 6 digital outputs
- Relay module for 115 VAC
- 6 normally open contact
- Outputs single channel isolated

<b>Short description</b>	<b>X20DO6529</b>
I/O module	6 digital outputs 30 VDC / 115 VAC, outputs are single-channel isolated
<b>Digital outputs</b>	<b>X20DO6529</b>
Design	Relay / N.O. Channels are single-channel isolated
Rated voltage	30 VDC / 115 VAC
Rated frequency	DC / 45 to 63 Hz
Rated output current	1.0 A at 30 VDC / 0.5 A at 115 VAC
Total current	6.0 A at 30 VDC / 3.0 A at 115 VAC
Switching capacity	
Minimum	0.01 mA / 10 mV DC
Maximum	30 W / 62.5 VA
Actuator supply	External
<b>General information</b>	<b>X20DO6529</b>
Status indicators	I/O function per channel, operating state, module status
Diagnostics	
Module run/error	Yes, with status LED and software status
Outputs	Yes, with status LED
Electrical isolation	
Channel - Bus	Yes
Channel - Channel	Yes
Power consumption	
Bus	1.1 W
I/O internal	-
Certification	CE, C-UL-US, GOST-R
<b>Operational conditions</b>	<b>X20DO6529</b>
Operating temperature	
Horizontal installation	0°C to +55°C
Vertical installation	0°C to +50°C
Relative humidity	5 to 95%, non-condensing
Mounting orientation	Horizontal or vertical
Installation at altitudes above sea level	
0 - 2000 m	No derating
>2000 m	Reduction of ambient temperature by 0.5°C per 100 m
Protection type	IP20
<b>Storage and transport conditions</b>	<b>X20DO6529</b>
Temperature	-25°C to +70°C
Relative humidity	5 to 95%, non-condensing
<b>Mechanical characteristics</b>	<b>X20DO6529</b>
Spacing	12.5 <sup>+0.2</sup> mm
Comment	Order terminal block 1x X20TB12 separately Order bus module 1x X20BM11 separately

### Pin assignments

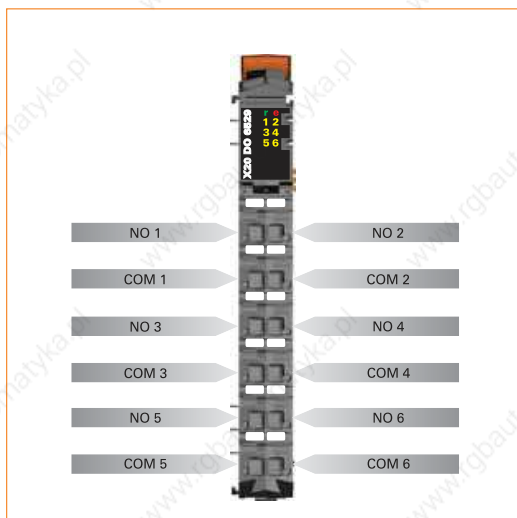

### Connection example

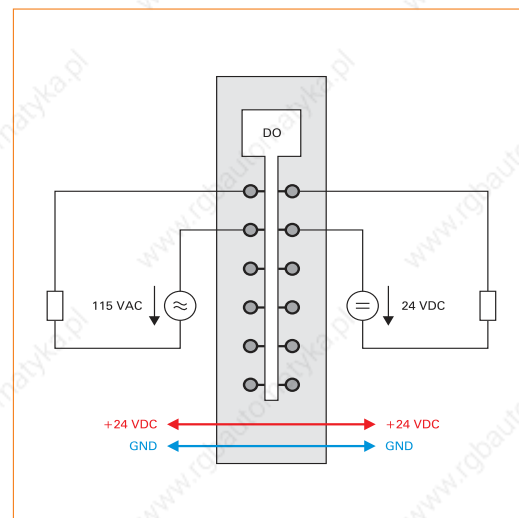

#### Required accessories

X20TB12	X20 terminal block, 12-pin, 24 V coded	94
X20BM11	X20 bus module, 24 V coded, internal I/O supply is interconnected	88

## Digital output module DO8322



- 8 digital outputs
- Source connection
- 1-wire connection
- Integrated output protection

<b>Short description</b>	<b>X20DO8322</b>
I/O module	Eight 24 VDC digital outputs for 1-wire connections
<b>Digital outputs</b>	<b>X20DO8322</b>
Rated voltage	24 VDC
Rated output current	0.5 A
Total current	4.0 A
Connection type	1-line connections
Output circuit	Source
Output protection	Thermal cutoff for overcurrent and short circuit, integrated protection for switching inductances
<b>General information</b>	<b>X20DO8322</b>
Status indicators	I/O function per channel, operating state, module status
<b>Diagnostics</b>	
Module run/error	Yes, with status LED and software status
Outputs	Yes, with status LED and software status (output error status)
<b>Electrical isolation</b>	
Channel - Bus	Yes
Channel - Channel	No
<b>Power consumption</b>	
Bus	0.26 W
I/O internal	0.8 W
Certification	CE, C-UL-US in preparation, GOST-R, BG-PRÜFZERT <sup>1)</sup>
1) Operating principle checked: Shutdown initiated by external safety switching device	
<b>Operational conditions</b>	<b>X20DO8322</b>
<b>Operating temperature</b>	
Horizontal installation	0°C to +55°C
Vertical installation	0°C to +50°C
<b>Relative humidity</b>	5 to 95%, non-condensing
<b>Mounting orientation</b>	Horizontal or vertical
<b>Installation at altitudes above sea level</b>	
0 - 2000 m	No derating
>2000 m	Reduction of ambient temperature by 0.5°C per 100 m
<b>Protection type</b>	IP20
<b>Storage and transport conditions</b>	<b>X20DO8322</b>
Temperature	-25°C to +70°C
Relative humidity	5 to 95%, non-condensing
<b>Mechanical characteristics</b>	<b>X20DO8322</b>
Spacing	12.5 <sup>+0.2</sup> mm
Comment	Order terminal block 1x X20TB12 separately Order bus module 1x X20BM11 separately

## Pin assignments

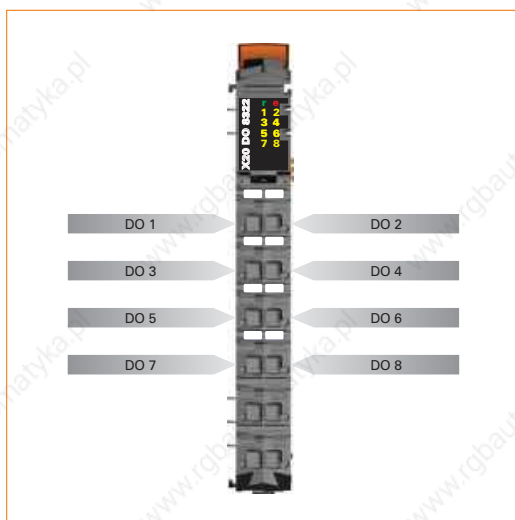

## Connection example

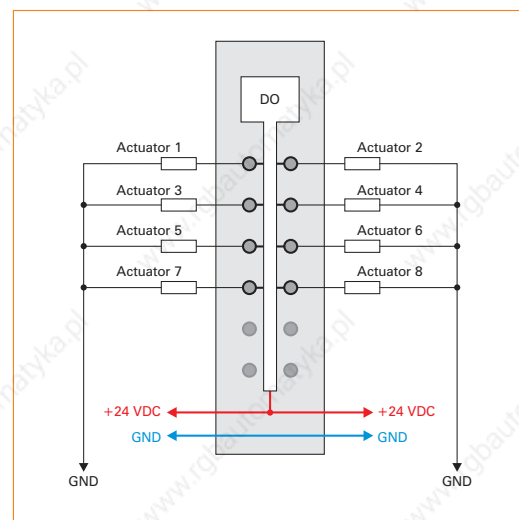

### Required accessories

X20TB12	X20 terminal block, 12-pin, 24 V coded	94
X20BM11	X20 bus module, 24 V coded, internal I/O supply is interconnected	88

## Digital output module DO8331



- 8 digital outputs with 2 A
- Sink connection
- 1-wire connection
- Power supply integrated in the module integrated
- Integrated output protection

<b>Short description</b>	<b>X20DO8331</b>
I/O module	Eight 24 VDC digital outputs for 1-wire connections
<b>Digital outputs</b>	<b>X20DO8331</b>
Rated voltage	24 VDC
Rated output current	2.0 A
Total current	8.0 A
Connection type	1-line connections
Output circuit	Sink
Output protection	Thermal cutoff for overcurrent and short circuit, integrated protection for switching inductances, reverse polarity protection for supply voltage
Additional functions for outputs	To increase the output current, outputs can be switched in parallel
<b>General information</b>	<b>X20DO8331</b>
Status indicators	I/O function per channel, operating state, module status
<b>Diagnostics</b>	
Module run/error	Yes, with status LED and software status
Outputs	Yes, with status LED and software status (output error status)
Supply voltage monitoring	Yes, with software status
<b>Electrical isolation</b>	
Channel - Bus	Yes
Channel - Channel	No
<b>Power consumption</b>	
Bus	0.22 W
I/O internal	-
I/O external	0.9 W
Certification	CE, C-UL-US, GOST-R
<b>Operational conditions</b>	<b>X20DO8331</b>
<b>Operating temperature</b>	
Horizontal installation	0°C to +55°C
Vertical installation	0°C to +50°C
Relative humidity	5 to 95%, non-condensing
Mounting orientation	Horizontal or vertical
<b>Installation at altitudes above sea level</b>	
0 - 2000 m	No derating
>2000 m	Reduction of ambient temperature by 0.5°C per 100 m
Protection type	IP20
<b>Storage and transport conditions</b>	<b>X20DO8331</b>
Temperature	-25°C to +70°C
Relative humidity	5 to 95%, non-condensing
<b>Mechanical characteristics</b>	<b>X20DO8331</b>
Spacing	12.5 <sup>+0.2</sup> mm
Comment	Order terminal block 1x X20TB12 separately Order bus module 1x X20BM11 separately

*The output supply is fed directly to the module. An additional supply module is not needed. There is no connection between the module and the I/O supply potential on the bus module.*

## Pin assignments

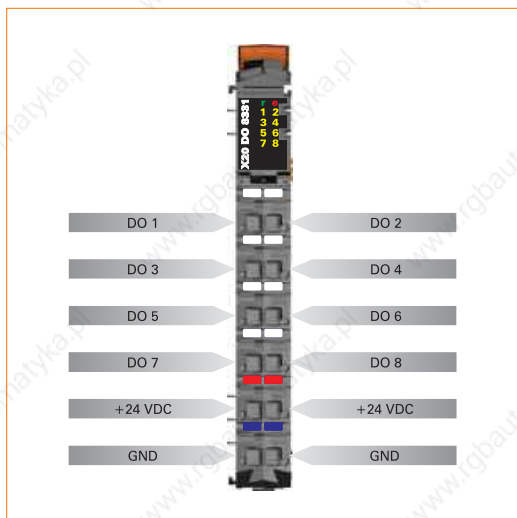

## Connection example

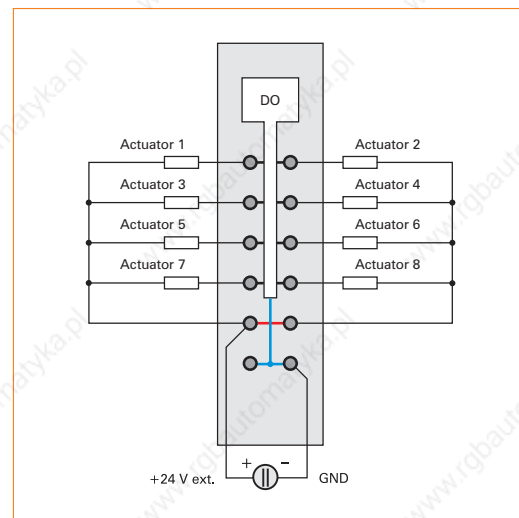

### Required accessories

X20TB12	X20 terminal block, 12-pin, 24 V coded	94
X20BM11	X20 bus module, 24 V coded, internal I/O supply is interconnected	88

## Digital output module DO8332



- 8 digital outputs with 2 A
- source connection
- 1-wire connection
- Power supply integrated in the module integrated
- Integrated output protection

<b>Short description</b>	<b>X20DO8332</b>
I/O module	Eight 24 VDC digital outputs for 1-wire connections
<b>Digital outputs</b>	<b>X20DO8332</b>
Rated voltage	24 VDC
Rated output current	2.0 A
Total current	8.0 A
Connection type	1-line connections
Output circuit	Source
Output protection	Thermal cutoff for overcurrent and short circuit, integrated protection for switching inductances, reverse polarity protection for supply voltage
Additional functions for outputs	To increase the output current, outputs can be switched in parallel
<b>General information</b>	<b>X20DO8332</b>
Status indicators	I/O function per channel, operating state, module status
<b>Diagnostics</b>	
Module run/error	Yes, with status LED and software status
Outputs	Yes, with status LED and software status (output error status)
Supply voltage monitoring	Yes, with software status
<b>Electrical isolation</b>	
Channel - Bus	Yes
Channel - Channel	No
<b>Power consumption</b>	
Bus	0.22 W
I/O internal	-
I/O external	0.92 W
Certification	CE, C-UL-US, GOST-R
<b>Operational conditions</b>	<b>X20DO8332</b>
<b>Operating temperature</b>	
Horizontal installation	0°C to +55°C
Vertical installation	0°C to +50°C
Relative humidity	5 to 95%, non-condensing
Mounting orientation	Horizontal or vertical
<b>Installation at altitudes above sea level</b>	
0 - 2000 m	No derating
>2000 m	Reduction of ambient temperature by 0.5°C per 100 m
Protection type	IP20
<b>Storage and transport conditions</b>	<b>X20DO8332</b>
Temperature	-25°C to +70°C
Relative humidity	5 to 95%, non-condensing
<b>Mechanical characteristics</b>	<b>X20DO8332</b>
Spacing	12.5 <sup>+0.2</sup> mm
Comment	Order terminal block 1x X20TB12 separately Order bus module 1x X20BM11 separately

*The output supply is fed directly to the module. An additional supply module is not needed. There is no connection between the module and the I/O supply potential on the bus module.*

### Pin assignments

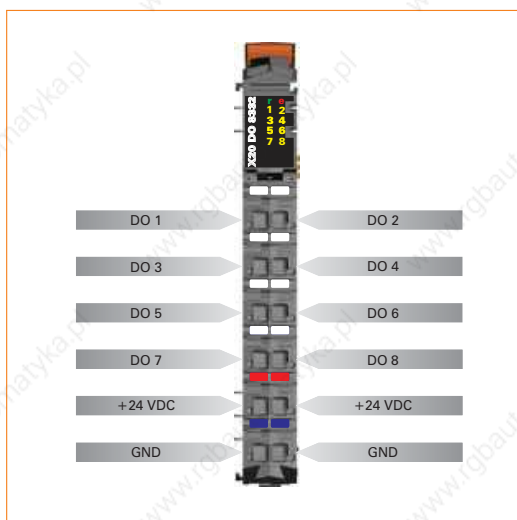

### Connection example

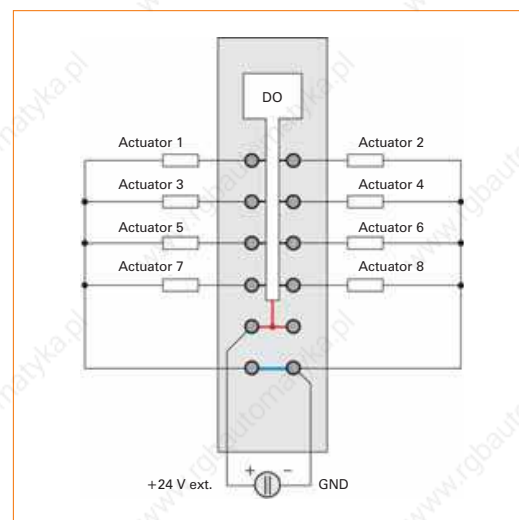

#### Required accessories

X20TB12	X20 terminal block, 12-pin, 24 V coded	94
X20BM11	X20 bus module, 24 V coded, internal I/O supply is interconnected	88

## Digital output module DO9321



- 12 digital outputs
- Sink connection
- 1-wire connection
- Integrated output protection

<b>Short description</b>	<b>X20DO9321</b>
I/O module	Twelve 24 VDC digital outputs for 1-wire connections
<b>Digital outputs</b>	<b>X20DO9321</b>
Rated voltage	24 VDC
Rated output current	0.5 A
Total current	6.0 A
Connection type	1-line connections
Output circuit	Sink
Output protection	Thermal cutoff for overcurrent and short circuit, integrated protection for switching inductances
<b>General information</b>	<b>X20DO9321</b>
Status indicators	I/O function per channel, operating state, module status
<b>Diagnostics</b>	
Module run/error	Yes, with status LED and software status
Outputs	Yes, with status LED and software status (output error status)
<b>Electrical isolation</b>	
Channel - Bus	Yes
Channel - Channel	No
<b>Power consumption</b>	
Bus	0.26 W
I/O internal	0.99 W
Certification	CE, C-UL-US, GOST-R, BG-PRÜFZERT <sup>1)</sup>
1) Operating principle checked: Shutdown initiated by external safety switching device	
<b>Operational conditions</b>	<b>X20DO9321</b>
<b>Operating temperature</b>	
Horizontal installation	0°C to +55°C
Vertical installation	0°C to +50°C
<b>Relative humidity</b>	5 to 95%, non-condensing
<b>Mounting orientation</b>	Horizontal or vertical
<b>Installation at altitudes above sea level</b>	
0 - 2000 m	No derating
>2000 m	Reduction of ambient temperature by 0.5°C per 100 m
<b>Protection type</b>	IP20
<b>Storage and transport conditions</b>	<b>X20DO9321</b>
Temperature	-25°C to +70°C
Relative humidity	5 to 95%, non-condensing
<b>Mechanical characteristics</b>	<b>X20DO9321</b>
Spacing	12.5 <sup>+0.2</sup> mm
<b>Comment</b>	Order terminal block 1x X20TB12 separately Order bus module 1x X20BM11 separately

### Pin assignments

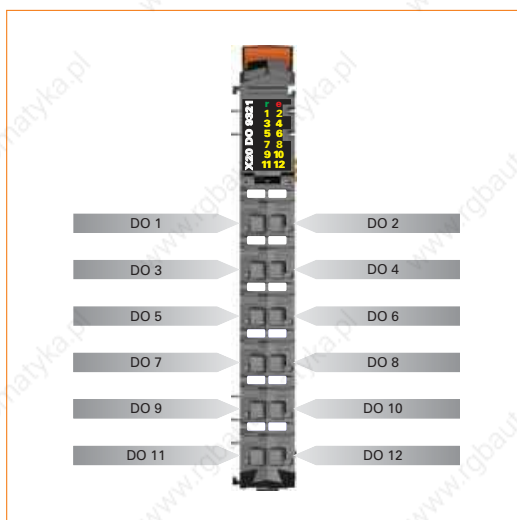

### Connection example

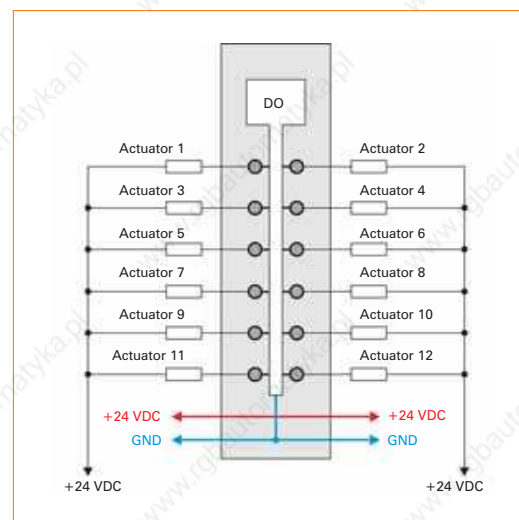

#### Required accessories

X20TB12	X20 terminal block, 12-pin, 24 V coded	94
X20BM11	X20 bus module, 24 V coded, internal I/O supply is interconnected	88

## Digital output module DO9322



- 12 digital outputs
- Source connection
- 1-wire connection
- Integrated output protection

<b>Short description</b>	<b>X20DO9322</b>
I/O module	Twelve 24 VDC digital outputs for 1-wire connections
<b>Digital outputs</b>	<b>X20DO9322</b>
Rated voltage	24 VDC
Rated output current	0.5 A
Total current	6.0 A
Connection type	1-line connections
Output circuit	Source
Output protection	Thermal cutoff for overcurrent and short circuit, integrated protection for switching inductances
<b>General information</b>	<b>X20DO9322</b>
Status indicators	I/O function per channel, operating state, module status
<b>Diagnostics</b>	
Module run/error	Yes, with status LED and software status
Outputs	Yes, with status LED and software status (output error status)
<b>Electrical isolation</b>	
Channel - Bus	Yes
Channel - Channel	No
<b>Power consumption</b>	
Bus	0.26 W
I/O internal	1.15 W
Certification	CE, C-UL-US, GOST-R, BG-PRÜFZERT <sup>1)</sup>
1) Operating principle checked: Shutdown initiated by external safety switching device	
<b>Operational conditions</b>	<b>X20DO9322</b>
<b>Operating temperature</b>	
Horizontal installation	0°C to +55°C
Vertical installation	0°C to +50°C
<b>Relative humidity</b>	5 to 95%, non-condensing
<b>Mounting orientation</b>	Horizontal or vertical
<b>Installation at altitudes above sea level</b>	
0 - 2000 m	No derating
>2000 m	Reduction of ambient temperature by 0.5°C per 100 m
<b>Protection type</b>	IP20
<b>Storage and transport conditions</b>	<b>X20DO9322</b>
Temperature	-25°C to +70°C
Relative humidity	5 to 95%, non-condensing
<b>Mechanical characteristics</b>	<b>X20DO9322</b>
Spacing	12.5 <sup>+0.2</sup> mm
<b>Comment</b>	Order terminal block 1x X20TB12 separately Order bus module 1x X20BM11 separately

## Pin assignments

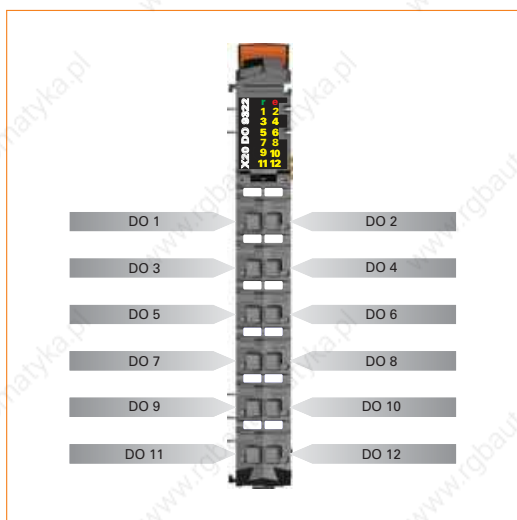

## Connection example

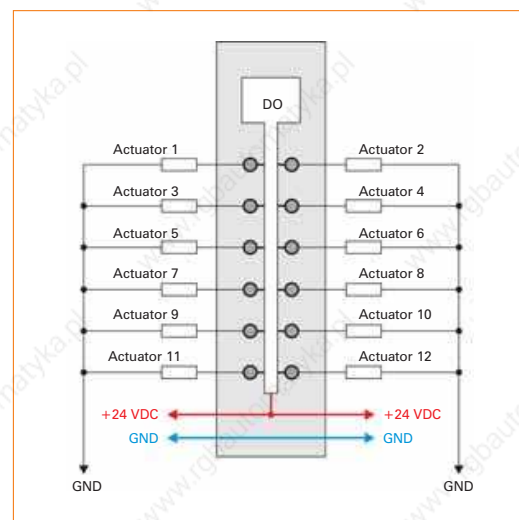

### Required accessories

X20TB12	X20 terminal block, 12-pin, 24 V coded	94
X20BM11	X20 bus module, 24 V coded, internal I/O supply is interconnected	88

## Digital mixed module DM9324



- 8 digital inputs, sink connection
- 4 digital outputs, source connection
- 1-wire connection
- Software input filter can be configured for the entire module
- Integrated output protection

<b>Short description</b>	<b>X20DM9324</b>
I/O module	Eight 24 VDC digital inputs for 1-wire connections, four 24 VDC digital outputs for 1-wire connections
Rated voltage	24 VDC
<b>Digital inputs</b>	<b>X20DM9324</b>
Input filter	
Hardware	≤100 μs
Software	Default 1 ms, can be configured between 0 and 25 ms in 0.2 ms intervals
Connection type	1-line connections
Input circuit	Sink
<b>Digital outputs</b>	<b>X20DM9324</b>
Rated output current	0.5 A
Total current	2.0 A
Connection type	1-line connections
Output circuit	Source
Output protection	Thermal cutoff for overcurrent or short circuit, integrated protection for switching inductances
<b>General information</b>	<b>X20DM9324</b>
Status indicators	I/O function per channel, operating state, module status
Diagnostics	
Module run/error	Yes, with status LED and software status
Outputs	Yes, with status LED and software status (output error status)
Electrical isolation	
Channel - Bus	Yes
Channel - Channel	No
Power consumption	
Bus	0.21 W
I/O internal	0.5 W
I/O external	1.17 W
Certification	CE, C-UL-US, GOST-R
<b>Operational conditions</b>	<b>X20DM9324</b>
Operating temperature	
Horizontal installation	0°C to +55°C
Vertical installation	0°C to +50°C
Relative humidity	5 to 95%, non-condensing
Mounting orientation	Horizontal or vertical
Installation at altitudes above sea level	
0 - 2000 m	No derating
>2000 m	Reduction of ambient temperature by 0.5°C per 100 m
Protection type	IP20
<b>Storage and transport conditions</b>	<b>X20DM9324</b>
Temperature	-25°C to +70°C
Relative humidity	5 to 95%, non-condensing
<b>Mechanical characteristics</b>	<b>X20DM9324</b>
Spacing	12.5 <sup>+0.2</sup> mm
Comment	Order terminal block 1x X20TB12 separately Order bus module 1x X20BM11 separately

### Pin assignments

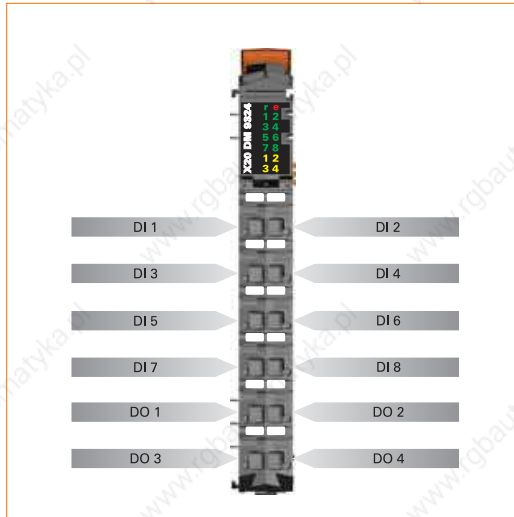

### Connection example

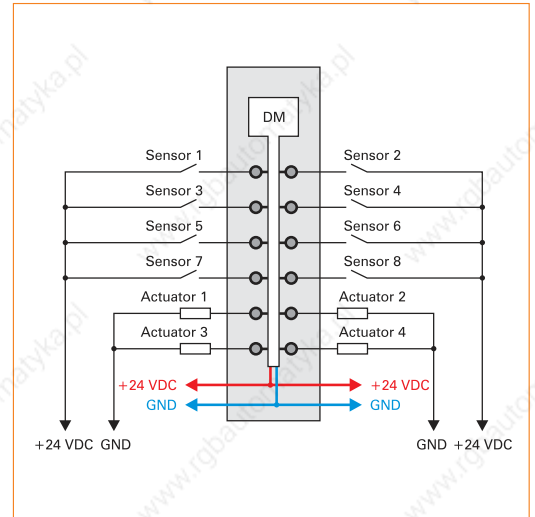

#### Required accessories

X20TB12	X20 terminal block, 12-pin, 24 V coded	94
X20BM11	X20 bus module, 24 V coded, internal I/O supply is interconnected	88

## Analog input module AI1744



- 1 full-bridge strain gauge input
- Advanced filter functions
- Data output rate up to 7.5 kHz

<b>Short description</b>	<b>X20AI1744</b>
I/O module	1 full-bridge strain gauge input
<b>Full-bridge strain gauge</b>	<b>X20AI1744</b>
Measurement area	$\pm 2$ to $\pm 16$ mV/V, set using software
Digital converter resolution	24-bit
Data output rate	2.5 - 7500 scans per second, can be set using software
Operating range / measurement sensor	85 to 5000 $\Omega$
Bridge voltage	5.5 VDC / max. 65 mA
Short circuit, overload protection	Yes
Connection	4-wire connection
<b>General information</b>	<b>X20AI1744</b>
Status indicators	Channel status, operating status, module status
Diagnostics	
Module run/error	Yes, with status LED and software status
Input	Yes, with status LED and software status
Wire break	Yes, with software status
Electrical isolation	
Bus - Analog input	Yes
Bus - Bridge supply voltage	Yes
Power consumption	
Bus	0.01 W
I/O internal	1.25 W
Certification	CE, C-UL-US, GOST-R
<b>Operational conditions</b>	<b>X20AI1744</b>
Operating temperature	
Horizontal installation	0°C to +55°C
Vertical installation	0°C to +50°C
Relative humidity	5 to 95%, non-condensing
Mounting orientation	Horizontal or vertical
Installation at altitudes above sea level	
0 - 2000 m	No derating
>2000 m	Reduction of ambient temperature by 0.5°C per 100 m
Protection type	IP20
<b>Storage and transport conditions</b>	<b>X20AI1744</b>
Temperature	-25°C to +70°C
Relative humidity	5 to 95%, non-condensing
<b>Mechanical characteristics</b>	<b>X20AI1744</b>
Spacing	12.5 <sup>+0.2</sup> mm
Comment	Order terminal block 1x X20TB12 separately Order bus module 1x X20BM11 separately

### Pin assignments

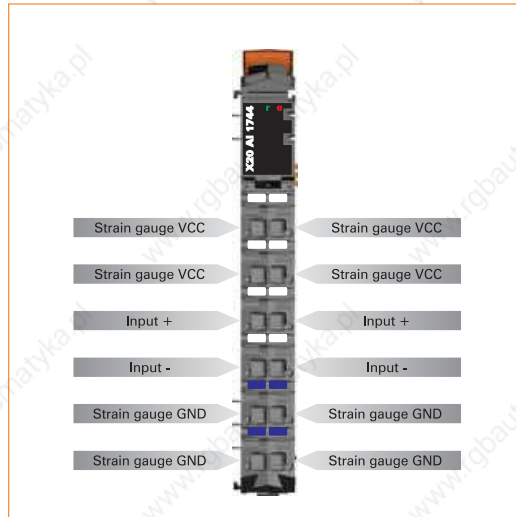

### Connection example

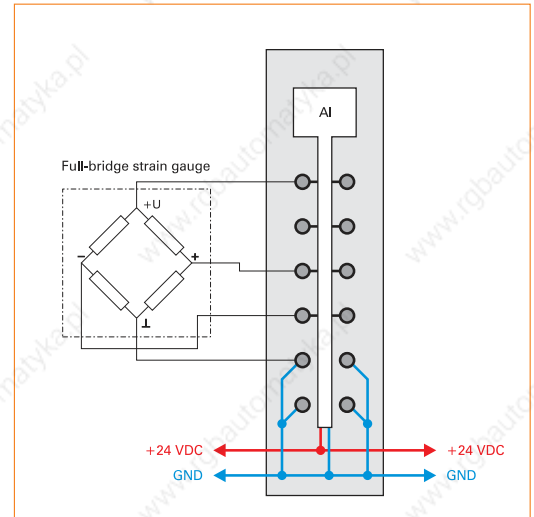

#### Required accessories

X20TB12	X20 terminal block, 12-pin, 24 V coded	94
X20BM11	X20 bus module, 24 V coded, internal I/O supply is interconnected	88

## Analog input module AI2622



- 2 analog inputs
- Either current or voltage signal
- 13-bit digital converter resolution

<b>Short description</b>	<b>X20AI2622</b>	
I/O module	2 analog inputs $\pm 10$ V or 0 to 20 mA / 4 to 20 mA	
<b>Analog inputs</b>	<b>Voltage</b>	<b>Current</b>
Input	$\pm 10$ V or 0 to 20 mA/4 to 20 mA, using different connection terminal points	
Input type	Differential input	
Digital converter resolution	$\pm 12$ -bit	12-bit
Conversion time	300 $\mu$ s for all inputs	
Output format	UINT	
Input impedance in signal range	20 M $\Omega$	
Load	-	< 400 $\Omega$
Maximum error at 25°C		
Gain	0.08% <sup>1)</sup>	0 to 20 mA = 0.08% <sup>1)</sup> / 4 to 20 mA = 0.1% <sup>1)</sup>
Offset	0.015% <sup>2)</sup>	0 to 20 mA = 0.03% <sup>3)</sup> / 4 to 20 mA = 0.0375% <sup>3)</sup>
Input protection	Protection against wiring with supply voltage	
1) Based on the current measurement value.		
2) Refers to the 20 V measurement range.		
3) Refers to the 20 mA measurement range.		
<b>General information</b>	<b>X20AI2622</b>	
Status indicators	I/O function per channel, operating state, module status	
<b>Diagnostics</b>		
Module run/error	Yes, with status LED and software status	
Inputs	Yes, with status LED and software status	
Channel type	Yes, with software status	
<b>Electrical isolation</b>		
Channel - Bus	Yes	
Channel - Channel	No	
<b>Power consumption</b>		
Bus	0.01 W	
I/O internal	0.8 W	
Certification	CE, C-UL-US, GOST-R	
<b>Operational conditions</b>	<b>X20AI2622</b>	
<b>Operating temperature</b>		
Horizontal installation	0°C to +55°C	
Vertical installation	0°C to +50°C	
Relative humidity	5 to 95%, non-condensing	
Mounting orientation	Horizontal or vertical	
<b>Installation at altitudes above sea level</b>		
0 - 2000 m	No derating	
>2000 m	Reduction of ambient temperature by 0.5°C per 100 m	
Protection type	IP20	
<b>Storage and transport conditions</b>	<b>X20AI2622</b>	
Temperature	-25°C to +70°C	
Relative humidity	5 to 95%, non-condensing	
<b>Mechanical characteristics</b>	<b>X20AI2622</b>	
Spacing	12.5 <sup>+0.2</sup> mm	
Comment	Order terminal block 1x X20TB06 or X20TB12 separately Order bus module 1x X20BM11 separately	

*The module is designed for X20 6-pin terminal blocks. However, the 12-pin terminal block can also be used.*

## Pin assignments



## Connection example

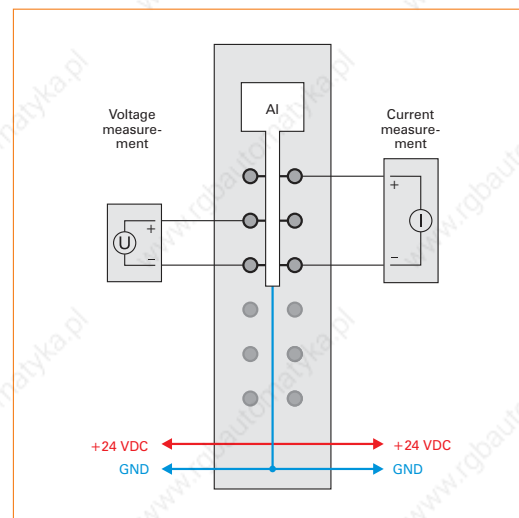

### Required accessories

X20TB06	X20 terminal block, 6-pin, 24 V coded	94
X20TB12	X20 terminal block, 12-pin, 24 V coded	94
X20BM11	X20 bus module, 24 V coded, internal I/O supply is interconnected	88

## Analog input module AI2632



- 2 analog inputs
- Either current or voltage signal
- 16-bit digital converter resolution
- Simultaneous input conversion
- Very fast conversion time

<b>Short description</b>	<b>X20AI2632</b>	
I/O module	2 analog inputs, $\pm 10$ V or 0 to 20 mA	
<b>Analog inputs</b>	<b>Voltage</b>	<b>Current</b>
Input	$\pm 10$ V or 0 to 20 mA, using different connection terminal points	
Input type	Differential input	
Digital converter resolution	$\pm 15$ -bit	15-bit
Conversion time	50 $\mu$ s for all inputs	
Output format	UINT	
Input impedance in signal range	20 M $\Omega$	-
Load	-	< 400 $\Omega$
Maximum error at 25°C		
Gain	0.08% <sup>1)</sup>	0.08% <sup>1)</sup>
Offset	0.01% <sup>2)</sup>	0.02% <sup>3)</sup>
Input protection	Protection against wiring with supply voltage	
1) Based on the current measurement value.		
2) Refers to the 20 V measurement range.		
3) Refers to the 20 mA measurement range.		
<b>General information</b>	<b>X20AI2632</b>	
Status indicators	I/O function per channel, operating state, module status	
Diagnostics		
Module run/error	Yes, with status LED and software status	
Inputs	Yes, with status LED and software status	
Channel type	Yes, with software status	
Electrical isolation		
Channel - Bus	Yes	
Channel - Channel	No	
Power consumption		
Bus	0.01 W	
I/O internal	1.2 W	
Certification	CE, C-UL-US, GOST-R	
<b>Operational conditions</b>	<b>X20AI2632</b>	
Operating temperature		
Horizontal installation	0°C to +55°C	
Vertical installation	0°C to +50°C	
Relative humidity	5 to 95%, non-condensing	
Mounting orientation	Horizontal or vertical	
Installation at altitudes above sea level		
0 - 2000 m	No derating	
>2000 m	Reduction of ambient temperature by 0.5°C per 100 m	
Protection type	IP20	
<b>Storage and transport conditions</b>	<b>X20AI2632</b>	
Temperature	-25°C to +70°C	
Relative humidity	5 to 95%, non-condensing	
<b>Mechanical characteristics</b>	<b>X20AI2632</b>	
Spacing	12.5 <sup>+0.2</sup> mm	
Comment	Order terminal block 1x X20TB06 or X20TB12 separately Order bus module 1x X20BM11 separately	

*The module is designed for X20 6-pin terminal blocks. However, the 12-pin terminal block can also be used.*

## Pin assignments



## Connection example

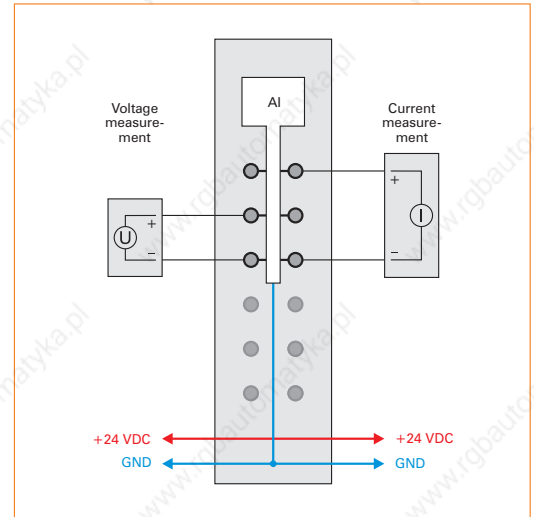

### Required accessories

X20TB06	X20 terminal block, 6-pin, 24 V coded	94
X20TB12	X20 terminal block, 12-pin, 24 V coded	94
X20BM11	X20 bus module, 24 V coded, internal I/O supply is interconnected	88

# Analog input module

## AI2632-1



- 2 analog inputs
- Either current or voltage signal
- 16-bit digital converter resolution
- Simultaneous input conversion
- Very fast conversion time

<b>Short description</b>	<b>X20AI2632-1</b>	
I/O module	2 analog inputs, $\pm 11$ V or 0 to 22 mA	
<b>Analog inputs</b>	<b>Voltage</b>	<b>Current</b>
Input	$\pm 11$ V or 0 to 22 mA, using different connection terminal points	
Input type	Differential input	
Digital converter resolution	$\pm 15$ -bit	15-bit
Conversion time	50 $\mu$ s for all inputs	
Output format	UINT	
Input impedance in signal range	20 M $\Omega$	-
Load	-	< 400 $\Omega$
Maximum error at 25°C		
Gain	0.08% <sup>1)</sup>	0.08% <sup>1)</sup>
Offset	0.01% <sup>2)</sup>	0.02% <sup>3)</sup>
Input protection	Protection against wiring with supply voltage	
1) Based on the current measurement value.		
2) Refers to the 22 V measurement range.		
3) Refers to the 22 mA measurement range.		
<b>General information</b>	<b>X20AI2632-1</b>	
Status indicators	I/O function per channel, operating state, module status	
Diagnostics		
Module run/error	Yes, with status LED and software status	
Inputs	Yes, with status LED and software status	
Channel type	Yes, with software status	
Electrical isolation		
Channel - Bus	Yes	
Channel - Channel	No	
Power consumption		
Bus	0.01 W	
I/O internal	1.2 W	
Certification	CE, C-UL-US, GOST-R	
<b>Operational conditions</b>	<b>X20AI2632-1</b>	
Operating temperature		
Horizontal installation	0°C to +55°C	
Vertical installation	0°C to +50°C	
Relative humidity	5 to 95%, non-condensing	
Mounting orientation	Horizontal or vertical	
Installation at altitudes above sea level		
0 - 2000 m	No derating	
>2000 m	Reduction of ambient temperature by 0.5°C per 100 m	
Protection type	IP20	
<b>Storage and transport conditions</b>	<b>X20AI2632-1</b>	
Temperature	-25°C to +70°C	
Relative humidity	5 to 95%, non-condensing	
<b>Mechanical characteristics</b>	<b>X20AI2632-1</b>	
Spacing	12.5 <sup>+0.2</sup> mm	
Comment	Order terminal block 1x X20TB06 or X20TB12 separately Order bus module 1x X20BM11 separately	

*The module is designed for X20 6-pin terminal blocks. However, the 12-pin terminal block can also be used.*

## Pin assignments

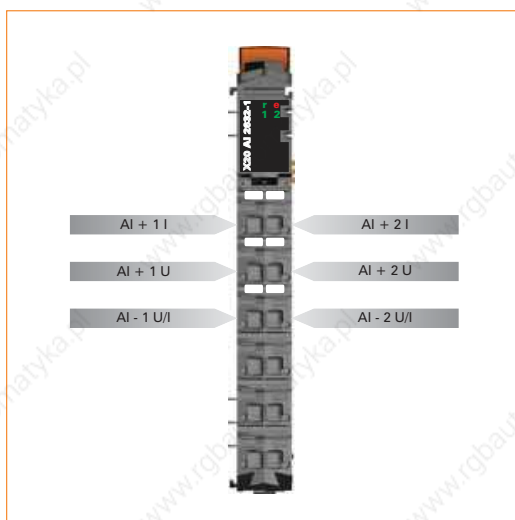

## Connection example

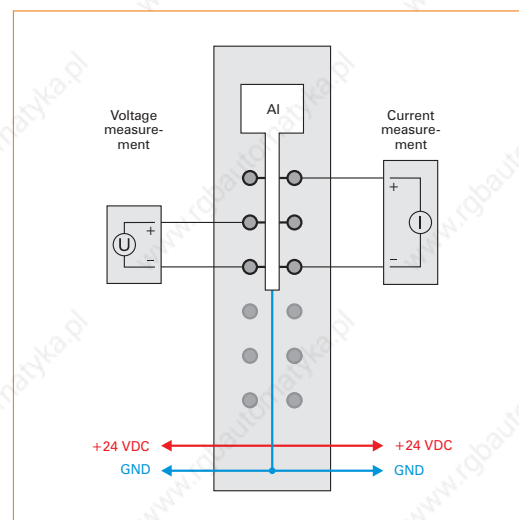

### Required accessories

X20TB06	X20 terminal block, 6-pin, 24 V coded	94
X20TB12	X20 terminal block, 12-pin, 24 V coded	94
X20BM11	X20 bus module, 24 V coded, internal I/O supply is interconnected	88

## Analog input module AI4622



- 4 analog inputs
- Either current or voltage signal
- 13-bit digital converter resolution

<b>Short description</b>	<b>X20AI4622</b>	
I/O module	4 analog inputs $\pm 10$ V or 0 to 20 mA / 4 to 20 mA	
<b>Analog inputs</b>	<b>Voltage</b>	<b>Current</b>
Input	$\pm 10$ V or 0 to 20 mA/4 to 20 mA, using different connection terminal points	
Input type	Differential input	
Digital converter resolution	$\pm 12$ -bit	12-bit
Conversion time	400 $\mu$ s for all inputs	
Output format	UINT	
Input impedance in signal range	20 M $\Omega$	-
Load	-	< 400 $\Omega$
Maximum error at 25°C		
Gain	0.08% <sup>1)</sup>	0 to 20 mA = 0.08% <sup>1)</sup> / 4 to 20 mA = 0.1% <sup>1)</sup>
Offset	0.015% <sup>2)</sup>	0 to 20 mA = 0.03% <sup>3)</sup> / 4 to 20 mA = 0.0375% <sup>3)</sup>
Input protection	Protection against wiring with supply voltage	
1) Based on the current measurement value.		
2) Refers to the 20 V measurement range.		
3) Refers to the 20 mA measurement range.		
<b>General information</b>	<b>X20AI4622</b>	
Status indicators	I/O function per channel, operating state, module status	
<b>Diagnostics</b>		
Module run/error	Yes, with status LED and software status	
Inputs	Yes, with status LED and software status	
Channel type	Yes, with software status	
<b>Electrical isolation</b>		
Channel - Bus	Yes	
Channel - Channel	No	
<b>Power consumption</b>		
Bus	0.01 W	
I/O internal	1.1 W	
Certification	CE, C-UL-US, GOST-R	
<b>Operational conditions</b>	<b>X20AI4622</b>	
<b>Operating temperature</b>		
Horizontal installation	0°C to +55°C	
Vertical installation	0°C to +50°C	
Relative humidity	5 to 95%, non-condensing	
Mounting orientation	Horizontal or vertical	
<b>Installation at altitudes above sea level</b>		
0 - 2000 m	No derating	
>2000 m	Reduction of ambient temperature by 0.5°C per 100 m	
Protection type	IP20	
<b>Storage and transport conditions</b>	<b>X20AI4622</b>	
Temperature	-25°C to +70°C	
Relative humidity	5 to 95%, non-condensing	
<b>Mechanical characteristics</b>	<b>X20AI4622</b>	
Spacing	12.5 <sup>+0.2</sup> mm	
Comment	Order terminal block 1x X20TB12 separately Order bus module 1x X20BM11 separately	

## Pin assignments

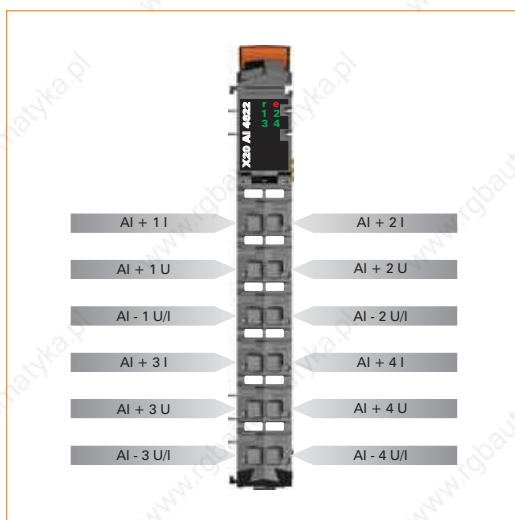

## Connection example

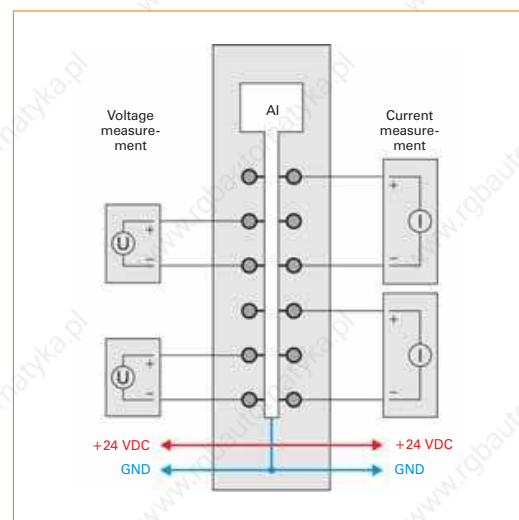

### Required accessories

X20TB12	X20 terminal block, 12-pin, 24 V coded	94
X20BM11	X20 bus module, 24 V coded, internal I/O supply is interconnected	88

# Analog input module AI4632



- 4 analog inputs
- Either current or voltage signal
- 16-bit digital converter resolution
- Simultaneous conversion of the inputs
- Very fast conversion time

<b>Short description</b>	<b>X20AI4632</b>	
I/O module	4 analog inputs, $\pm 10$ V or 0 to 20 mA	
<b>Analog inputs</b>	<b>Voltage</b>	<b>Current</b>
Input	$\pm 10$ V or 0 to 20 mA, using different connection terminal points	
Input type	Differential input	
Digital converter resolution	$\pm 15$ -bit	15-bit
Conversion time	50 $\mu$ s for all inputs	
Output format	UINT	
Input impedance in signal range	20 M $\Omega$	
Load	-	< 400 $\Omega$
Maximum error at 25°C		
Gain	0.08% <sup>1)</sup>	0.08% <sup>1)</sup>
Offset	0.01% <sup>2)</sup>	0.02% <sup>3)</sup>
Input protection	Protection against wiring with supply voltage	
1) Based on the current measurement value.		
2) Refers to the 20 V measurement range.		
3) Refers to the 20 mA measurement range.		
<b>General information</b>	<b>X20AI4632</b>	
Status indicators	I/O function per channel, operating state, module status	
Diagnostics		
Module run/error	Yes, with status LED and software status	
Inputs	Yes, with status LED and software status	
Channel type	Yes, with software status	
Electrical isolation		
Channel - Bus	Yes	
Channel - Channel	No	
Power consumption		
Bus	0.01 W	
I/O internal	1.5 W	
Certification	CE, C-UL-US, GOST-R	
<b>Operational conditions</b>	<b>X20AI4632</b>	
Operating temperature		
Horizontal installation	0°C to +55°C	
Vertical installation	0°C to +50°C	
Relative humidity	5 to 95%, non-condensing	
Mounting orientation	Horizontal or vertical	
Installation at altitudes above sea level		
0 - 2000 m	No derating	
>2000 m	Reduction of ambient temperature by 0.5°C per 100 m	
Protection type	IP20	
<b>Storage and transport conditions</b>	<b>X20AI4632</b>	
Temperature	-25°C to +70°C	
Relative humidity	5 to 95%, non-condensing	
<b>Mechanical characteristics</b>	<b>X20AI4632</b>	
Spacing	12.5 <sup>+0.2</sup> mm	
Comment	Order terminal block 1x X20TB12 separately Order bus module 1x X20BM11 separately	

### Pin assignments

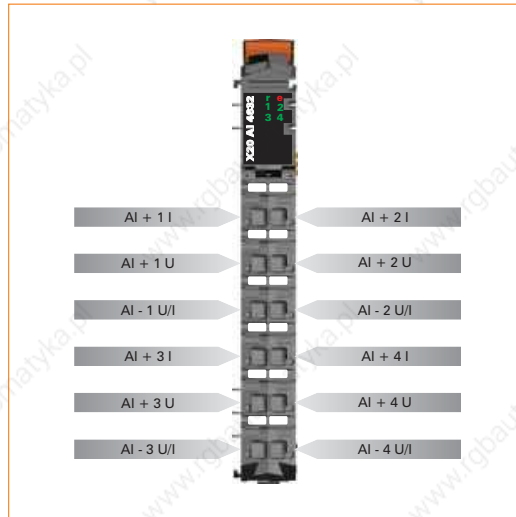

### Connection example

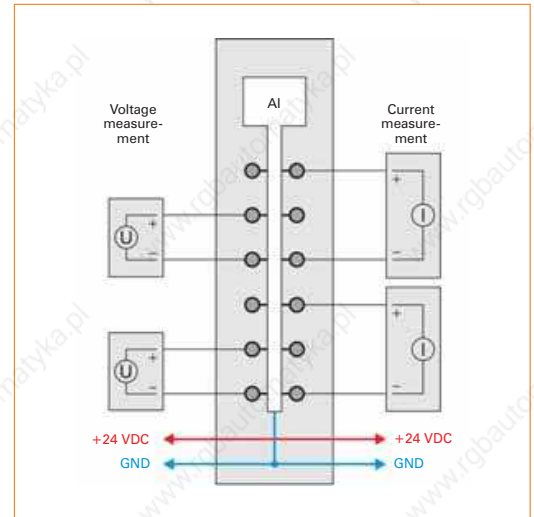

#### Required accessories

X20TB12	X20 terminal block, 12-pin, 24 V coded	94
X20BM11	X20 bus module, 24 V coded, internal I/O supply is interconnected	88

# Analog input module

## AI4632-1



- 4 analog inputs
- Either current or voltage signal
- 16-bit digital converter resolution
- Simultaneous conversion of the inputs
- Very fast conversion time

<b>Short description</b>	<b>X20AI4632-1</b>	
I/O module	4 analog inputs, $\pm 11$ V or 0 to 22 mA	
<b>Analog inputs</b>	<b>Voltage</b>	<b>Current</b>
Input	$\pm 11$ V or 0 to 22 mA, using different connection terminal points	
Input type	Differential input	
Digital converter resolution	$\pm 15$ -bit	15-bit
Conversion time	50 $\mu$ s for all inputs	
Output format	UINT	
Input impedance in signal range	20 M $\Omega$	-
Load	-	< 400 $\Omega$
Maximum error at 25°C		
Gain	0.08% <sup>1)</sup>	0.08% <sup>1)</sup>
Offset	0.01% <sup>2)</sup>	0.02% <sup>3)</sup>
Input protection	Protection against wiring with supply voltage	
1) Based on the current measurement value.		
2) Refers to the 22 V measurement range.		
3) Refers to the 22 mA measurement range.		
<b>General information</b>	<b>X20AI4632-1</b>	
Status indicators	I/O function per channel, operating state, module status	
Diagnostics		
Module run/error	Yes, with status LED and software status	
Inputs	Yes, with status LED and software status	
Channel type	Yes, with software status	
Electrical isolation		
Channel - Bus	Yes	
Channel - Channel	No	
Power consumption		
Bus	0.01 W	
I/O internal	1.5 W	
Certification	CE, C-UL-US, GOST-R	
<b>Operational conditions</b>	<b>X20AI4632-1</b>	
Operating temperature		
Horizontal installation	0°C to +55°C	
Vertical installation	0°C to +50°C	
Relative humidity	5 to 95%, non-condensing	
Mounting orientation	Horizontal or vertical	
Installation at altitudes above sea level		
0 - 2000 m	No derating	
>2000 m	Reduction of ambient temperature by 0.5°C per 100 m	
Protection type	IP20	
<b>Storage and transport conditions</b>	<b>X20AI4632-1</b>	
Temperature	-25°C to +70°C	
Relative humidity	5 to 95%, non-condensing	
<b>Mechanical characteristics</b>	<b>X20AI4632-1</b>	
Spacing	12.5 <sup>+0.2</sup> mm	
Comment	Order terminal block 1x X20TB12 separately Order bus module 1x X20BM11 separately	

### Pin assignments

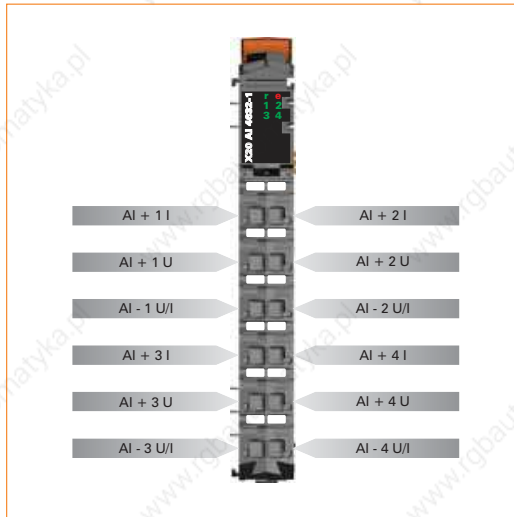

### Connection example

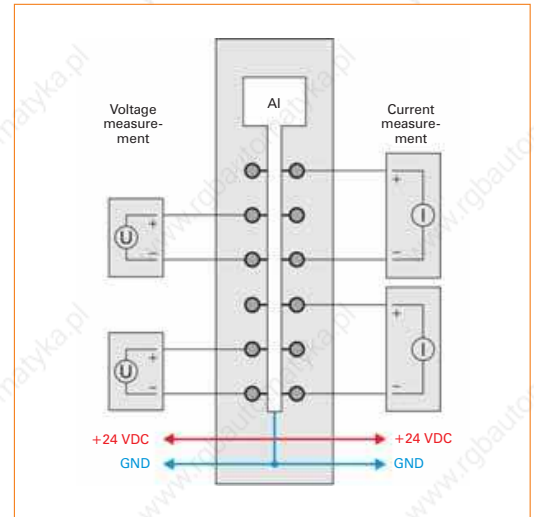

#### Required accessories

X20TB12	X20 terminal block, 12-pin, 24 V coded	94
X20BM11	X20 bus module, 24 V coded, internal I/O supply is interconnected	88

## Analog output module AO2622



- 2 analog outputs
- Either current or voltage signal
- 12-bit digital converter resolution

<b>Short description</b>	<b>X20AO2622</b>
I/O module	2 analog outputs, $\pm 10$ V or 0 to 20 mA
<b>Analog outputs</b>	<b>X20AO2622</b>
Output	$\pm 10$ V or 0 to 20 mA, using different connection terminal points
Digital converter resolution	12-bit
Conversion time	200 $\mu$ s for all outputs
Power on/off behavior	Internal enable relay for boot procedure and errors
Maximum error at 25°C	
Gain	0.15%, based on the current output value
Offset	0.05%, based on the entire output range
Output protection	Short circuit protection
<b>General information</b>	<b>X20AO2622</b>
Status indicators	I/O function per channel, operating state, module status
Diagnostics	
Module run/error	Yes, with status LED and software status
Channel type	Yes, with software status
Electrical isolation	
Channel - Bus	Yes
Channel - Channel	No
Power consumption	
Bus	0.01 W
I/O internal	1.1 W
Certification	CE, C-UL-US, GOST-R
<b>Operational conditions</b>	<b>X20AO2622</b>
Operating temperature	
Horizontal installation	0°C to +55°C
Vertical installation	0°C to +50°C
Relative humidity	5 to 95%, non-condensing
Mounting orientation	Horizontal or vertical
Installation at altitudes above sea level	
0 - 2000 m	No derating
>2000 m	Reduction of ambient temperature by 0.5°C per 100 m
Protection type	IP20
<b>Storage and transport conditions</b>	<b>X20AO2622</b>
Temperature	-25°C to +70°C
Relative humidity	5 to 95%, non-condensing
<b>Mechanical characteristics</b>	<b>X20AO2622</b>
Spacing	12.5 <sup>+0.2</sup> mm
Comment	Order terminal block 1x X20TB06 or X20TB12 separately Order bus module 1x X20BM11 separately

*The module is designed for X20 6-pin terminal blocks. However, the 12-pin terminal block can also be used.*

## Pin assignments



## Connection example

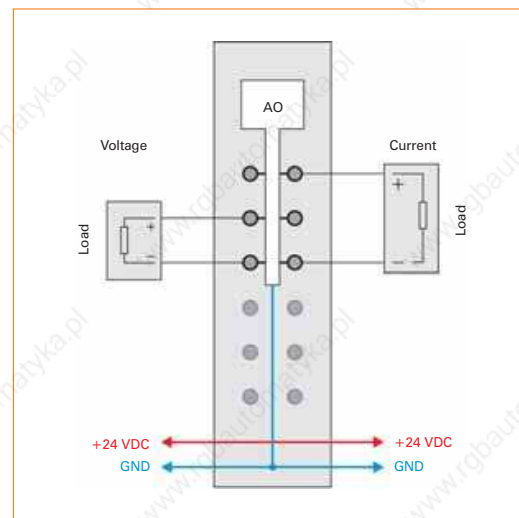

### Required accessories

X20TB06	X20 terminal block, 6-pin, 24 V coded	94
X20TB12	X20 terminal block, 12-pin, 24 V coded	94
X20BM11	X20 bus module, 24 V coded, internal I/O supply is interconnected	88

## Analog output module AO2632



- 2 analog outputs
- Either current or voltage signal
- 16-bit digital converter resolution

<b>Short description</b>	<b>X20AO2632</b>	
I/O module	2 analog outputs, $\pm 10$ V or 0 to 20 mA	
<b>Analog outputs</b>	<b>X20AO2632</b>	
Output	$\pm 10$ V or 0 to 20 mA, using different connection terminal points	
Digital converter resolution	16-bit	
Conversion time	50 $\mu$ s for all outputs	
Power on/off behavior	Internal enable relay for boot procedure and errors	
Maximum error at 25°C		
Gain	0.045%, based on the current output value	
Offset	0.025%, based on the entire output range	
Output protection	Short circuit protection	
<b>General information</b>	<b>X20AO2632</b>	
Status indicators	I/O function per channel, operating state, module status	
Diagnostics		
Module run/error	Yes, with status LED and software status	
Channel type	Yes, with software status	
Electrical isolation		
Channel - Bus	Yes	
Channel - Channel	No	
Power consumption	Rev. <B0	Rev. $\geq$ B0
Bus	0.01 W	0.01 W
I/O internal	1.6 W	1.2 W
Certification	CE, C-UL-US, GOST-R	
<b>Operational conditions</b>	<b>X20AO2632</b>	
Operating temperature	Rev. <B0	Rev. $\geq$ B0
Horizontal installation	0°C to +50°C	0°C to +55°C
Vertical installation	0°C to +45°C	0°C to +50°C
Relative humidity	5 to 95%, non-condensing	
Mounting orientation	Horizontal or vertical	
Installation at altitudes above sea level		
0 - 2000 m	No derating	
>2000 m	Reduction of ambient temperature by 0.5°C per 100 m	
Protection type	IP20	
<b>Storage and transport conditions</b>	<b>X20AO2632</b>	
Temperature	-25°C to +70°C	
Relative humidity	5 to 95%, non-condensing	
<b>Mechanical characteristics</b>	<b>X20AO2632</b>	
Spacing	12.5 <sup>+0.2</sup> mm	
Comment	Order terminal block 1x X20TB06 or X20TB12 separately Order bus module 1x X20BM11 separately	

*The module is designed for X20 6-pin terminal blocks. However, the 12-pin terminal block can also be used.*

### Pin assignments



### Connection example

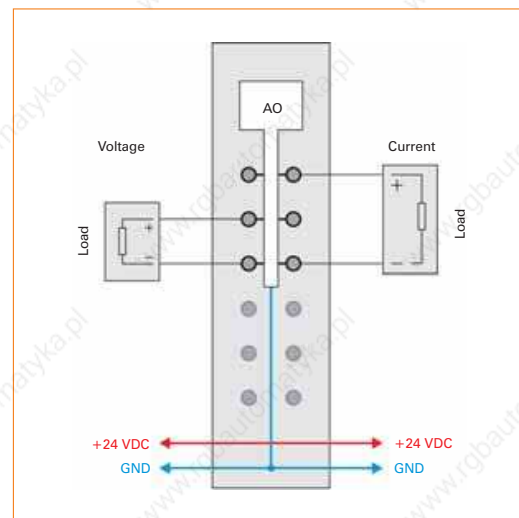

#### Required accessories

X20TB06	X20 terminal block, 6-pin, 24 V coded	94
X20TB12	X20 terminal block, 12-pin, 24 V coded	94
X20BM11	X20 bus module, 24 V coded, internal I/O supply is interconnected	88

# Analog output module AO4622



- 4 analog outputs
- Either current or voltage signal
- 12-bit digital converter resolution

<b>Short description</b>	<b>X20AO4622</b>
I/O module	4 analog outputs, $\pm 10$ V or 0 to 20 mA
<b>Analog outputs</b>	<b>X20AO4622</b>
Output	$\pm 10$ V or 0 to 20 mA, using different connection terminal points
Digital converter resolution	12-bit
Conversion time	300 $\mu$ s for all outputs
Power on/off behavior	Internal enable relay for boot procedure and errors
Maximum error at 25°C	
Gain	0.080%, based on the current output value
Offset	0.050%, based on the entire output range
Output protection	Short circuit protection
<b>General information</b>	<b>X20AO4622</b>
Status indicators	I/O function per channel, operating state, module status
Diagnostics	
Module run/error	Yes, with status LED and software status
Channel type	Yes, with software status
Electrical isolation	
Channel - Bus	Yes
Channel - Channel	No
Power consumption	
Bus	0.01 W
I/O internal	1.5 W
Certification	CE, C-UL-US, GOST-R
<b>Operational conditions</b>	<b>X20AO4622</b>
Operating temperature <sup>1)</sup>	
Horizontal installation	0°C to +55°C
Vertical installation	0°C to +45°C
Relative humidity	5 to 95%, non-condensing
Mounting orientation	Horizontal or vertical
Installation at altitudes above sea level	
0 - 2000 m	No derating
>2000 m	Reduction of ambient temperature by 0.5°C per 100 m
Protection type	IP20
1) See notes regarding derating and mixed operation in the module data sheet.	
<b>Storage and transport conditions</b>	<b>X20AO4622</b>
Temperature	-25°C to +70°C
Relative humidity	5 to 95%, non-condensing
<b>Mechanical characteristics</b>	<b>X20AO4622</b>
Spacing	12.5 <sup>+0.2</sup> mm
Comment	Order terminal block 1x X20TB12 separately Order bus module 1x X20BM11 separately

### Pin assignments

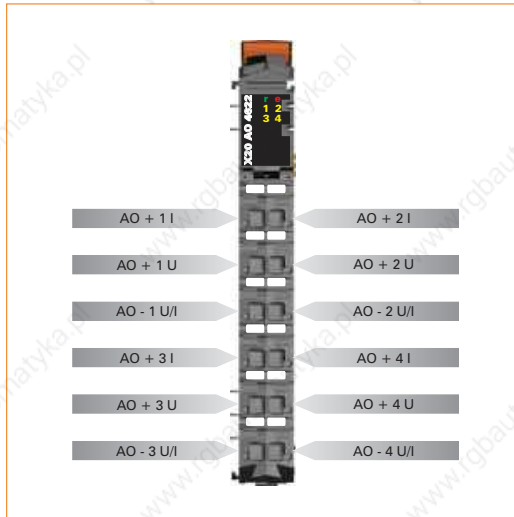

### Connection example

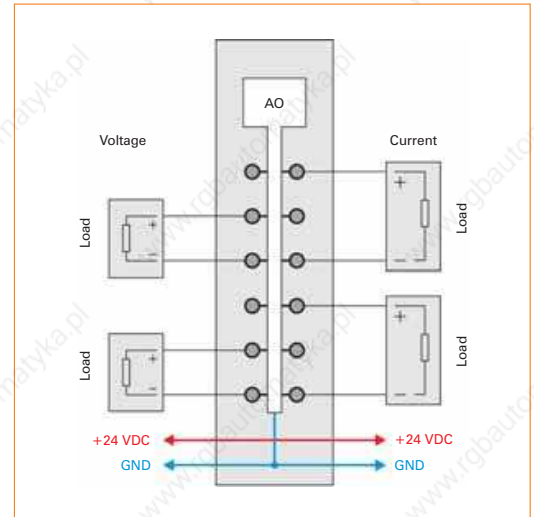

#### Required accessories

X20TB12	X20 terminal block, 12-pin, 24 V coded	94
X20BM11	X20 bus module, 24 V coded, internal I/O supply is interconnected	88

# Analog output module AO4632



- 4 analog outputs
- Either current or voltage signal
- 16-bit digital converter resolution

<b>Short description</b>	<b>X20AO4632</b>	
I/O module	4 analog outputs, $\pm 10$ V or 0 to 20 mA	
<b>Analog outputs</b>	<b>X20AO4632</b>	
Output	$\pm 10$ V or 0 to 20 mA, using different connection terminal points	
Digital converter resolution	16-bit	
Conversion time	50 $\mu$ s for all outputs	
Power on/off behavior	Internal enable relay for boot procedure and errors	
Maximum error at 25°C		
Gain	0.040%, based on the current output value	
Offset	0.022%, based on the entire output range	
Output protection	Short circuit protection	
<b>General information</b>	<b>X20AO4632</b>	
Status indicators	I/O function per channel, operating state, module status	
Diagnostics		
Module run/error	Yes, with status LED and software status	
Channel type	Yes, with software status	
Electrical isolation		
Channel - Bus	Yes	
Channel - Channel	No	
Power consumption	Rev. <B0	Rev. $\geq$ B0
Bus	0.01 W	0.01 W
I/O internal	2.0 W	1.5 W
Certification	CE, C-UL-US, GOST-R	
<b>Operational conditions</b>	<b>X20AO4632</b>	
Operating temperature	Rev. <B0	Rev. $\geq$ B0 <sup>1)</sup>
Horizontal installation	0°C to +45°C	0°C to +55°C
Vertical installation	0°C to +40°C	0°C to +45°C
Relative humidity	5 to 95%, non-condensing	
Mounting orientation	Horizontal or vertical	
Installation at altitudes above sea level		
0 - 2000 m	No derating	
>2000 m	Reduction of ambient temperature by 0.5°C per 100 m	
Protection type	IP20	
1) See notes regarding derating and mixed operation in the module data sheet.		
<b>Storage and transport conditions</b>	<b>X20AO4632</b>	
Temperature	-25°C to +70°C	
Relative humidity	5 to 95%, non-condensing	
<b>Mechanical characteristics</b>	<b>X20AO4632</b>	
Spacing	12.5 <sup>+0.2</sup> mm	
Comment	Order terminal block 1x X20TB12 separately Order bus module 1x X20BM11 separately	

### Pin assignments

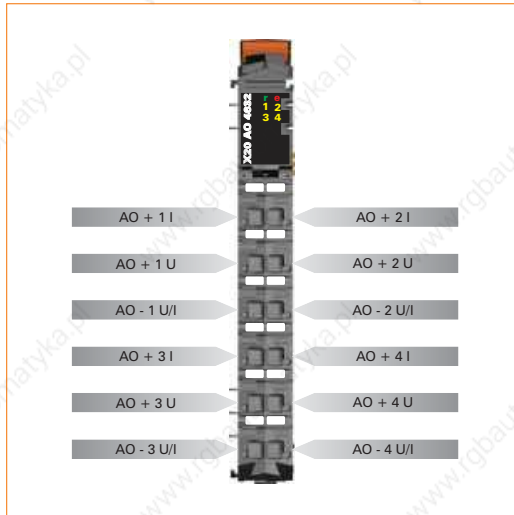

### Connection example

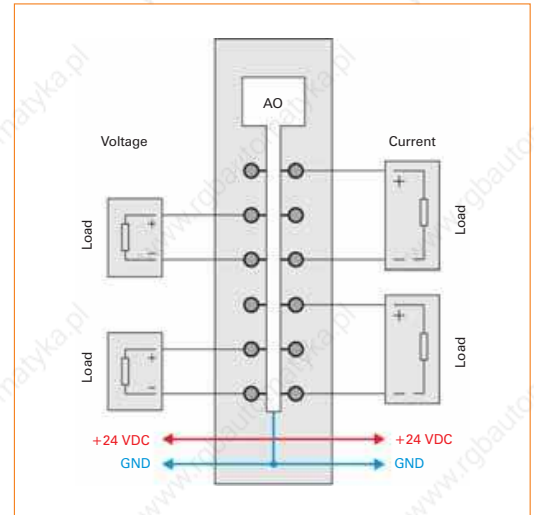

#### Required accessories

X20TB12	X20 terminal block, 12-pin, 24 V coded	94
X20BM11	X20 bus module, 24 V coded, internal I/O supply is interconnected	88

# Temperature module AT2222



- 2 inputs for resistance temperature measurement
- For PT100 and PT1000
- Sensor type can be set for each channel
- Direct resistance measurement
- 2 or 3-line connection can be configured for each module
- Filter time can be configured

<b>Short description</b>	<b>X20AT2222</b>
I/O module	2 inputs for PT100 or PT1000 resistance temperature measurement
<b>Temperature inputs resistance measurement</b>	<b>X20AT2222</b>
Input	Resistance measurement with constant current supply for 2 or 3-wire connections
Digital converter resolution	16-bit
Filter time	Configurable between 1 ms and 66.7 ms
Conversion time	
1 channel	20 ms at 50 Hz filter
2 channels	80 ms at 50 Hz filter
Output format	INT or UINT for resistance measurement
Maximum error at 25°C	
Gain	0.037%, based on the current resistance value
Offset	0.0015%, based on the entire resistance range
Sensor	Can be set per channel
PT100	-200°C to +850°C
PT1000	-200°C to +850°C
Resistance measurement range	0.1 Ω to 4500 Ω / 0.05 Ω to 2250 Ω
<b>General information</b>	<b>X20AT2222</b>
Status indicators	I/O function per channel, operating state, module status
Diagnostics	
Module run/error	Yes, with status LED and software status
Inputs	Yes, with status LED and software status
Electrical isolation	
Channel - Bus	Yes
Channel - Channel	No
Power consumption	
Bus	0.01 W
I/O internal	1.1 W
Certification	CE, C-UL-US, GOST-R
<b>Operational conditions</b>	<b>X20AT2222</b>
Operating temperature	
Horizontal installation	0°C to +55°C
Vertical installation	0°C to +50°C
Relative humidity	5 to 95%, non-condensing
Mounting orientation	Horizontal or vertical
Installation at altitudes above sea level	
0 - 2000 m	No derating
>2000 m	Reduction of ambient temperature by 0.5°C per 100 m
Protection type	IP20
<b>Storage and transport conditions</b>	<b>X20AT2222</b>
Temperature	-25°C to +70°C
Relative humidity	5 to 95%, non-condensing
<b>Mechanical characteristics</b>	<b>X20AT2222</b>
Spacing	12.5 <sup>+0.2</sup> mm
Comment	Order terminal block 1x X20TB06 or X20TB12 separately Order bus module 1x X20BM11 separately

*The module is designed for X20 6-pin terminal blocks. However, the 12-pin terminal block can also be used.*

### Pin assignments



### Connection example

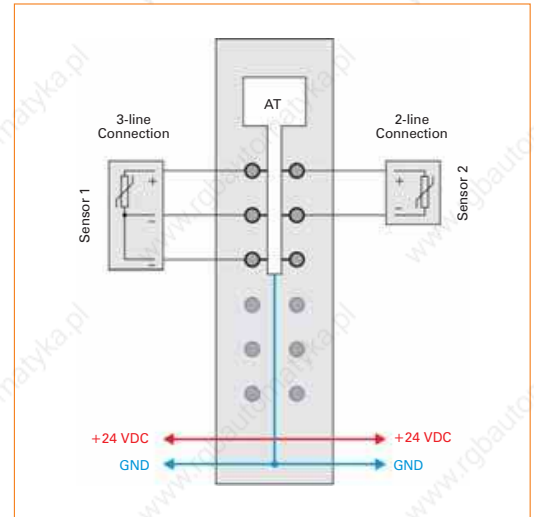

Required accessories		
X20TB06	X20 terminal block, 6-pin, 24 V coded	94
X20TB12	X20 terminal block, 12-pin, 24 V coded	94
X20BM11	X20 bus module, 24 V coded, internal I/O supply is interconnected	88

# Temperature module AT4222



- 4 inputs for resistance temperature measurement
- For PT100 and PT1000
- Sensor type can be set for each channel
- Direct resistance measurement
- 2 or 3-line connection can be configured for each module
- Filter time can be configured

<b>Short description</b>	<b>X20AT4222</b>
I/O module	4 inputs for PT100 or PT1000 resistance temperature measurement
<b>Temperature inputs resistance measurement</b>	<b>X20AT4222</b>
Input	Resistance measurement with constant current supply for 2 or 3-wire connections
Digital converter resolution	16-bit
Filter time	Configurable between 1 ms and 66.7 ms
Conversion time	
1 channel	20 ms at 50 Hz filter
2 - 4 channels	40 ms per channel with 50 Hz filter
Output format	INT or UINT for resistance measurement
Maximum error at 25°C	
Gain	0.037%, based on the current resistance value
Offset	0.0015%, based on the entire resistance range
Sensor	Can be set per channel
PT100	-200°C to +850°C
PT1000	-200°C to +850°C
Resistance measurement range	0.1 Ω to 4500 Ω / 0.05 Ω to 2250 Ω
<b>General information</b>	<b>X20AT4222</b>
Status indicators	I/O function per channel, operating state, module status
Diagnostics	
Module run/error	Yes, with status LED and software status
Inputs	Yes, with status LED and software status
Electrical isolation	
Channel - Bus	Yes
Channel - Channel	No
Power consumption	
Bus	0.01 W
I/O internal	1.1 W
Certification	CE, C-UL-US, GOST-R
<b>Operational conditions</b>	<b>X20AT4222</b>
Operating temperature	
Horizontal installation	0°C to +55°C
Vertical installation	0°C to +50°C
Relative humidity	5 to 95%, non-condensing
Mounting orientation	Horizontal or vertical
Installation at altitudes above sea level	
0 - 2000 m	No derating
>2000 m	Reduction of ambient temperature by 0.5°C per 100 m
Protection type	IP20
<b>Storage and transport conditions</b>	<b>X20AT4222</b>
Temperature	-25°C to +70°C
Relative humidity	5 to 95%, non-condensing
<b>Mechanical characteristics</b>	<b>X20AT4222</b>
Spacing	12.5 <sup>+0.2</sup> mm
Comment	Order terminal block 1x X20TB12 separately Order bus module 1x X20BM11 separately

## Pin assignments

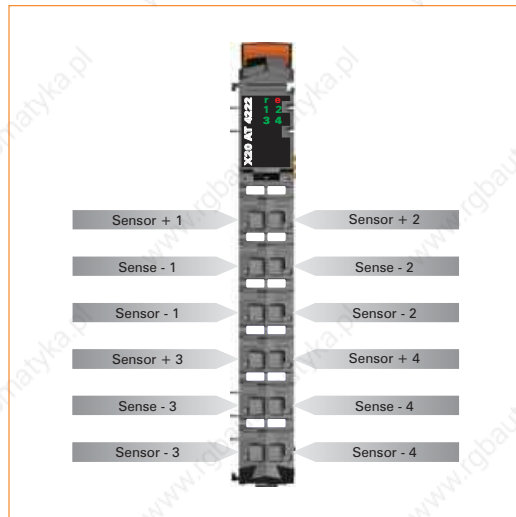

## Connection example

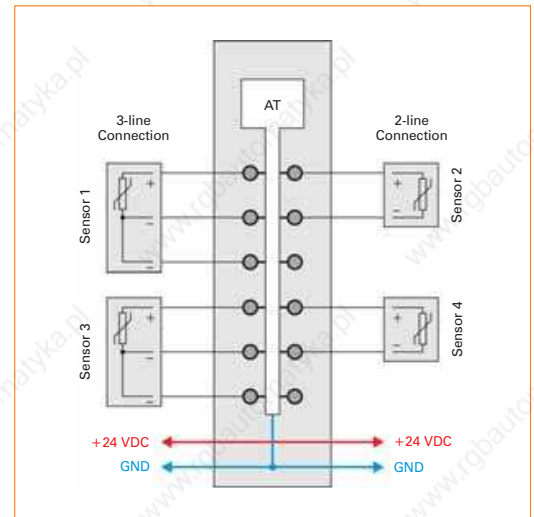

### Required accessories

X20TB12	X20 terminal block, 12-pin, 24 V coded	94
X20BM11	X20 bus module, 24 V coded, internal I/O supply is interconnected	88

# Temperature module AT2311



- 2 inputs for resistance temperature measurement
- PT100 sensor
- Direct resistance measurement
- 4-line measurement
- Filter time can be configured

<b>Short description</b>	<b>X20AT2311</b>
I/O module	2 inputs for PT100 resistance temperature measurement
<b>Temperature inputs resistance measurement</b>	<b>X20AT2311</b>
Input	Resistance measurement with constant current supply for 4 wire connection
Digital converter resolution	24-bit
Filter time	Configurable between 1 ms and 400 ms
Conversion time	
50 Hz filter	20 ms for all inputs
1000 Hz filter	1 ms for all inputs
Output format	DINT or UDINT for resistance measurement
Maximum error at 25°C	
Gain	0.0059%, based on the current resistance value
Offset	0.0015%, based on the entire resistance range
Temperature measurement range	-200°C to +850°C
Resistance measurement range	0.5 Ω to 390 Ω
<b>General information</b>	<b>X20AT2311</b>
Status indicators	I/O function per channel, operating state, module status
Diagnosics	
Module run/error	Yes, with status LED and software status
Inputs	Yes, with status LED and software status
Electrical isolation	
Channel - Bus	Yes
Channel - Channel	Yes
Power consumption	
Bus	0.35 W
I/O internal	0.85 W
Certification	CE, C-UL-US (in development), GOST-R
<b>Operational conditions</b>	<b>X20AT2311</b>
Operating temperature	
Horizontal installation	0°C to +55°C
Vertical installation	0°C to +50°C
Relative humidity	5 to 95%, non-condensing
Mounting orientation	Horizontal or vertical
Installation at altitudes above sea level	
0 - 2000 m	No derating
>2000 m	Reduction of ambient temperature by 0.5°C per 100 m
Protection type	IP20
<b>Storage and transport conditions</b>	<b>X20AT2311</b>
Temperature	-25°C to +70°C
Relative humidity	5 to 95%, non-condensing
<b>Mechanical characteristics</b>	<b>X20AT2311</b>
Spacing	12.5 <sup>+0.2</sup> mm
Comment	Order terminal block 1x X20TB12 separately Order bus module 1x X20BM11 separately

### Pin assignments

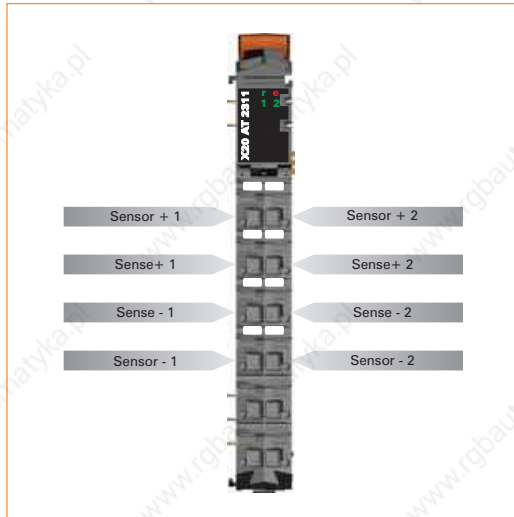

### Connection example

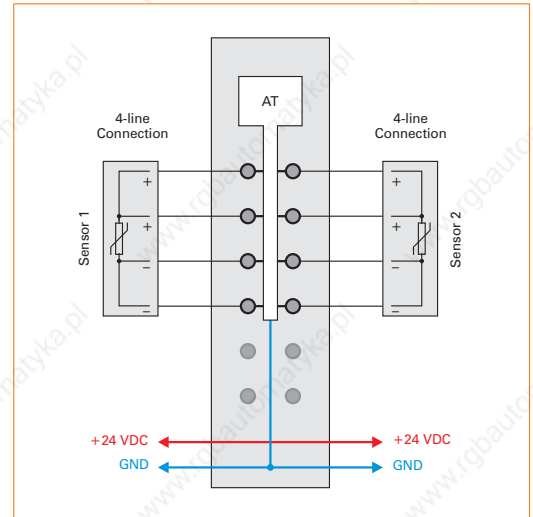

Required accessories		
X20TB12	X20 terminal block, 12-pin, 24 V coded	94
X20BM11	X20 bus module, 24 V coded, internal I/O supply is interconnected	88

## Temperature module AT2402



- 2 inputs for thermocouples
- For sensor types J, K, N, S
- Additional direct raw value measurement
- Integrated terminal temperature compensation
- Filter time can be configured

<b>Short description</b>	<b>X20AT2402</b>
I/O module	2 inputs for thermocouples
<b>Thermocouple temperature inputs</b>	<b>X20AT2402</b>
Input	Thermocouple
Digital converter resolution	16-bit
Filter time	Configurable between 1 ms and 66.7 ms
Conversion time	
1 channel	80.4 ms at 50 Hz filter
2 channels	120.6 ms at 50 Hz filter
Output format	UINT
Basic accuracy	
Type J	$\pm 0.10\%$ at 25°C <sup>1)</sup>
Type K	$\pm 0.11\%$ at 25°C <sup>1)</sup>
Type N (Rev. $\geq D0$ )	$\pm 0.11\%$ at 25°C <sup>1)</sup>
Type S	$\pm 0.17\%$ at 25°C <sup>1)</sup>
Measurement area	
Sensor temperature	
FeCuNi: Type J	-210°C to +1200°C
NiCrNi: Type K	-270°C to +1372°C
NiCrSi: Type N (Rev. $\geq D0$ )	-270°C to +1300°C
PtRhPt: Type S	-50°C to +1768°C
Terminal temperature	-25°C to +85°C
Raw value	$\pm 65.534$ mV
Terminal temperature compensation	Internal
<small>1) Refers to the measurement range without consideration of the reference junction measurement error</small>	
<b>General information</b>	<b>X20AT2402</b>
Status indicators	I/O function per channel, operating state, module status
Diagnostics	
Module run/error	Yes, with status LED and software status
Inputs	Yes, with status LED and software status
Electrical isolation	
Channel - Bus	Yes
Channel - Channel	No
Power consumption	
Bus	0.01 W
I/O internal	0.72 W
Certification	CE, C-UL-US, GOST-R

**The module is designed for X20 6-pin terminal blocks. However, the 12-pin terminal block can also be used.**

<b>Operational conditions</b>	<b>X20AT2402</b>
Operating temperature	
Horizontal installation	0°C to +55°C
Vertical installation	0°C to +50°C
Relative humidity	5 to 95%, non-condensing
Mounting orientation	Horizontal or vertical
Installation at altitudes above sea level	
0 - 2000 m	No derating
>2000 m	Reduction of ambient temperature by 0.5°C per 100 m
Protection type	IP20
<b>Storage and transport conditions</b>	<b>X20AT2402</b>
Temperature	-25°C to +70°C
Relative humidity	5 to 95%, non-condensing
<b>Mechanical characteristics</b>	<b>X20AT2402</b>
Spacing	12.5 <sup>+0.2</sup> mm
Comment	Order terminal block 1x X20TB06 or X20TB12 separately Order bus module 1x X20BM11 separately

### Pin assignments



### Connection example

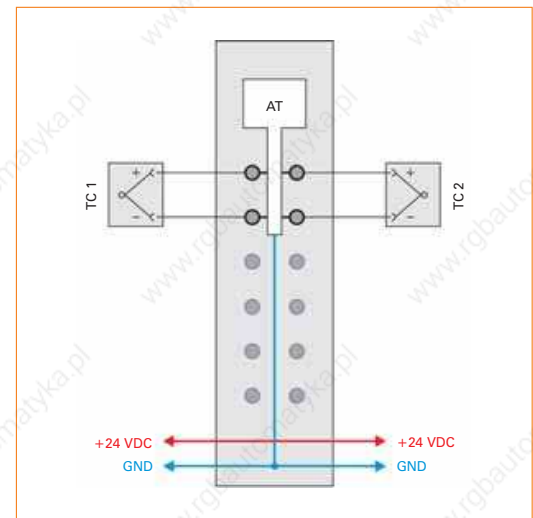

Required accessories		
X20TB06	X20 terminal block, 6-pin, 24 V coded	▮ 94
X20TB12	X20 terminal block, 12-pin, 24 V coded	▮ 94
X20BM11	X20 bus module, 24 V coded, internal I/O supply is interconnected	▮ 88

# Temperature module AT6402



- 6 inputs for thermocouples
- For sensor types J, K, N, S
- Additional direct raw value measurement
- Integrated terminal temperature compensation
- Filter time can be configured

<b>Short description</b>	<b>X20AT6402</b>
I/O module	6 inputs for thermocouples
<b>Thermocouple temperature inputs</b>	<b>X20AT6402</b>
Input	Thermocouple
Digital converter resolution	16-bit
Filter time	Configurable between 1 ms and 66.7 ms
Conversion time	
1 channel	80.4 ms at 50 Hz filter
n channels	(n + 1) x 40.2 ms at 50 Hz filter
Output format	UINT
Basic accuracy	
Type J	±0.10% at 25°C <sup>1)</sup>
Type K	±0.11% at 25°C <sup>1)</sup>
Type N (Rev. ≥D0)	±0.11% at 25°C <sup>1)</sup>
Type S	±0.17% at 25°C <sup>1)</sup>
Measurement area	
Sensor temperature	
FeCuNi: Type J	-210°C to +1200°C
NiCrNi: Type K	-270°C to +1372°C
NiCrSi: Type N (Rev. ≥D0)	-270°C to +1300°C
PtRhPt: Type S	-50°C to +1768°C
Terminal temperature	-25°C to +85°C
Raw value	±65.534 mV
Terminal temperature compensation	Internal
<small>1) Refers to the measurement range without consideration of the reference junction measurement error</small>	
<b>General information</b>	<b>X20AT6402</b>
Status indicators	I/O function per channel, operating state, module status
Diagnostics	
Module run/error	Yes, with status LED and software status
Inputs	Yes, with status LED and software status
Electrical isolation	
Channel - Bus	Yes
Channel - Channel	No
Power consumption	
Bus	0.01 W
I/O internal	0.91 W
Certification	CE, C-UL-US, GOST-R

<b>Operational conditions</b>	<b>X20AT6402</b>
Operating temperature	
Horizontal installation	0°C to +55°C
Vertical installation	0°C to +50°C
Relative humidity	5 to 95%, non-condensing
Mounting orientation	Horizontal or vertical
Installation at altitudes above sea level	
0 - 2000 m	No derating
>2000 m	Reduction of ambient temperature by 0.5°C per 100 m
Protection type	IP20
<b>Storage and transport conditions</b>	<b>X20AT6402</b>
Temperature	-25°C to +70°C
Relative humidity	5 to 95%, non-condensing
<b>Mechanical characteristics</b>	<b>X20AT6402</b>
Spacing	12.5 <sup>+0.2</sup> mm
Comment	Order terminal block 1x X20TB12 separately Order bus module 1x X20BM11 separately

### Pin assignments

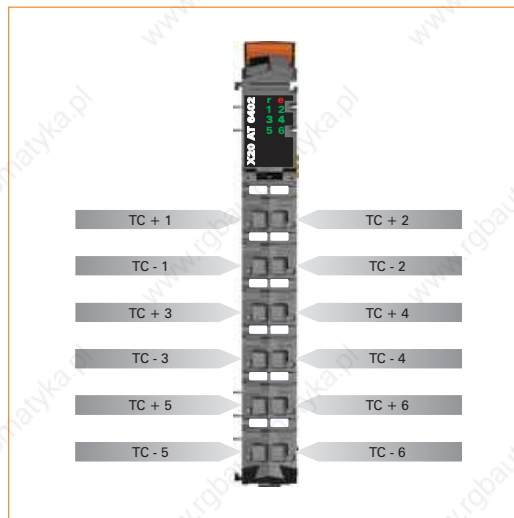

### Connection example

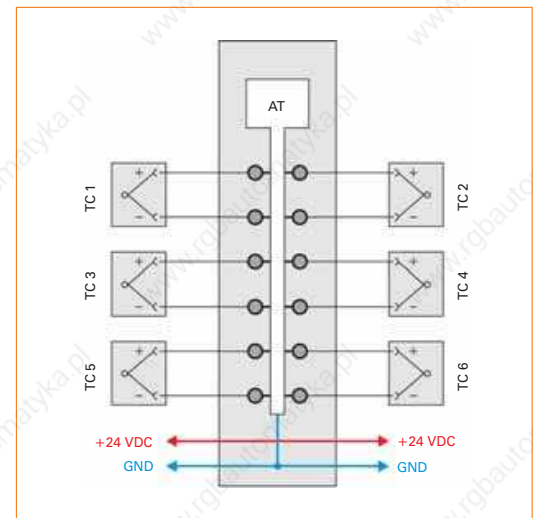

Required accessories		
X20TB12	X20 terminal block, 12-pin, 24 V coded	▣ 94
X20BM11	X20 bus module, 24 V coded, internal I/O supply is interconnected	▣ 88

# PWM motor bridge MM2436



The MM2436 PWM module can be used in many different ways. One use is the control of DC motors in the middle power range. The module can drive two single-phase brush-type DC motors. The module is designed for a rated voltage of 24 VDC to 39 VDC  $\pm 25\%$  at a rated current of 3 A (maximum current 3.5 A for 2 s).

- Controlling motors, valves and resistive loads
- Two outputs for constant current or PWM
- Adjustable dither
- Four inputs for digital input signals or for two AB encoders
- Power feed integrated in the module

<b>Short description</b>	<b>X20MM2436</b>
I/O module	2-channel PWM motor bridge, 2 AB incremental encoders
<b>Digital inputs</b>	<b>X20MM2436</b>
Number of channels	4
Rated voltage	24 VDC
Input filter	
Hardware	< 5 $\mu$ s
Software	-
Connection type	1-line connections
Input circuit	Sink
Additional functions for inputs	2x AB incremental encoder
<b>AB incremental encoders</b>	<b>X20MM2436</b>
Amount	2
Encoder inputs	24 V, asymmetrical
Counter size	16-bit
Input frequency (max.)	50 kHz
Evaluation	4x
<b>PWM output</b>	<b>X20MM2436</b>
Amount	2
Rated voltage	24 VDC - 39 VDC ( $\pm 25\%$ )
Rated current	3.0 A
Maximum current	3.5 A (2 s)
PWM frequency	15 Hz - 50 kHz
Output protection	No reverse polarity protection for supply voltage
<b>General information</b>	<b>X20MM2436</b>
Status indicators	I/O function per channel, operating state, module status
Diagnosics	
Module run/error	Yes, with status LED and software status
Output	Yes, with status LED and software status
I/O supply	Yes, with software status
Electrical isolation	
Channel - Bus	Yes
Channel - Channel	No
Power consumption	
Bus	0.01 W
I/O internal	-
I/O external	
24 VDC	2.45 W
48 VDC	3.15 W
Certification	CE, C-UL-US, GOST-R
<b>Operational conditions</b>	<b>X20MM2436</b>
Operating temperature	
Horizontal installation	0°C to +50°C
Relative humidity	5 to 95%, non-condensing
Mounting orientation	Horizontal
Installation at altitudes above sea level	
0 - 2000 m	No derating
>2000 m	Reduction of ambient temperature by 0.5°C per 100 m
Protection type	IP20

<b>Storage and transport conditions</b>	<b>X20MM2436</b>
Temperature	-25°C to +70°C
Relative humidity	5 to 95%, non-condensing
<b>Mechanical characteristics</b>	<b>X20MM2436</b>
Spacing	25 <sup>+0.2</sup> mm
Comment	Order terminal block 1x X20TB12 separately Order bus module 1x X20BM31 separately

### Pin assignments

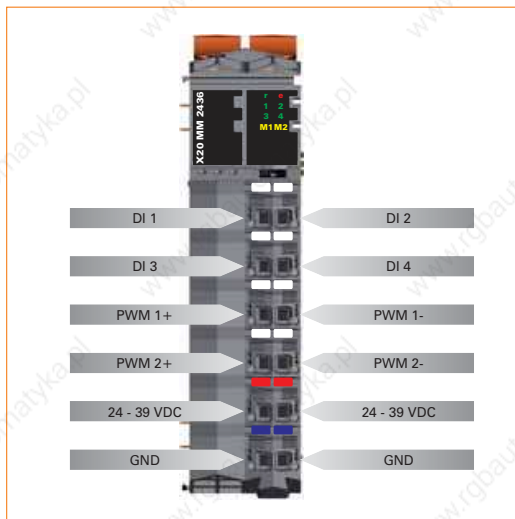

### Connection example

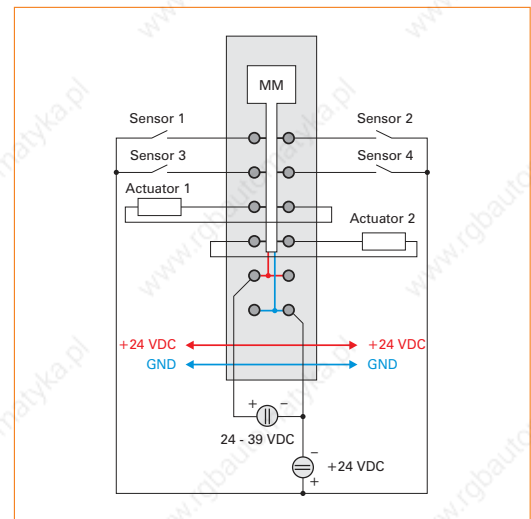

Required accessories		
X20TB12	X20 terminal block, 12-pin, 24 V coded	94
X20BM31	X20 bus module for double-width modules, internal I/O supply is interconnected	92

## PWM motor bridge MM4456



The MM4456 PWM module can be used in many different ways. One use is the control of DC motors in various power classes. The module can drive four single-phase brush-type DC motors. The module is designed for a rated voltage of 24 VDC to 48 VDC  $\pm 25\%$  at a rated current of 6 A (maximum current 10 A for 2 s).

- Controlling motors, valves and resistive loads
- Four outputs for constant current or PWM
- Adjustable dither
- 16 inputs for digital input signals or for four AB encoders
- Power feed integrated in the module

<b>Short description</b>	<b>X20MM4456</b>
I/O module	4-channel PWM motor bridges, 16 digital inputs, special functions
<b>Digital inputs</b>	<b>X20MM4456</b>
Number of channels	16
Rated voltage	24 VDC
Input filter	
Hardware	< 5 $\mu$ s
Software	-
Connection type	1-line connections
Input circuit	Sink
Additional functions for inputs	4x ABR incremental encoder
<b>ABR incremental encoder</b>	<b>X20MM4456</b>
Amount	4
Encoder inputs	24 V, asymmetrical
Counter size	16-bit
Input frequency (max.)	50 kHz
Evaluation	4x
<b>PWM output</b>	<b>X20MM4456</b>
Amount	4
Rated voltage	24 VDC - 48 VDC ( $\pm 25\%$ )
Rated current	6.0 A
Maximum current	10 A (2 s)
PWM frequency	15 Hz - 50 kHz
Output protection	No reverse polarity protection for supply voltage
<b>General information</b>	<b>X20MM4456</b>
Status indicators	I/O function per channel, operating state, module status
Diagnosics	
Module run/error	Yes, with status LED and software status
Output	Yes, with status LED and software status
I/O supply	Yes, with software status
Electrical isolation	
Channel - Bus	Yes
Channel - Channel	No
Power consumption	
Bus	0.01 W
I/O internal	2.0 W
I/O external	
24 VDC	0.01 W
48 VDC	0.01 W
Certification	CE, C-UL-US, GOST-R
<b>Operational conditions</b>	<b>X20MM4456</b>
Operating temperature	
Horizontal installation	0°C to +50°C
Relative humidity	5 to 95%, non-condensing
Mounting orientation	Horizontal
Installation at altitudes above sea level	
0 - 2000 m	No derating
>2000 m	Reduction of ambient temperature by 0.5°C per 100 m
Protection type	IP20
<b>Storage and transport conditions</b>	<b>X20MM4456</b>
Temperature	-25°C to +70°C
Relative humidity	5 to 95%, non-condensing
<b>Mechanical characteristics</b>	<b>X20MM4456</b>
Spacing	87.5 <sup>+0.2</sup> mm
Comment	Order terminal block 2x X20TB12 separately Order terminal block 1x 0TB3103-7020 separately

### Pin assignments for DI 1 - 8 / PWM 1 + 2

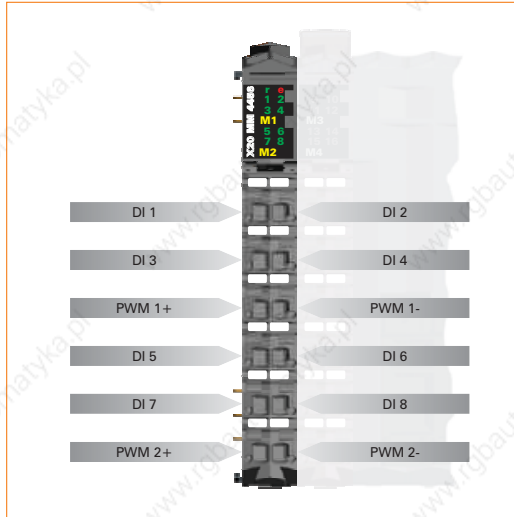

### Pin assignments for DI 9 - 16 / PWM 3 + 4

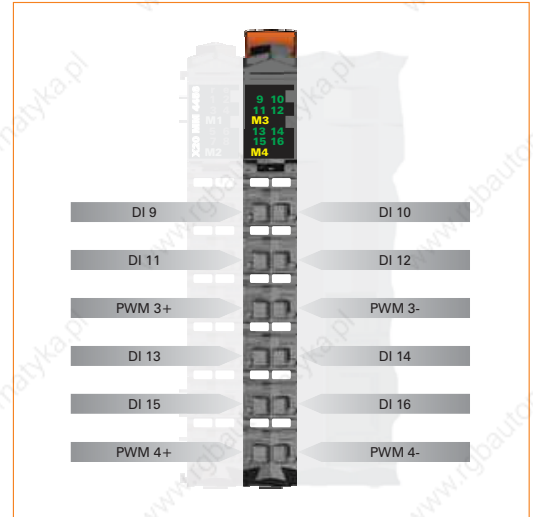

### Pin assignments for module supply



### Connection example for X1 terminal block

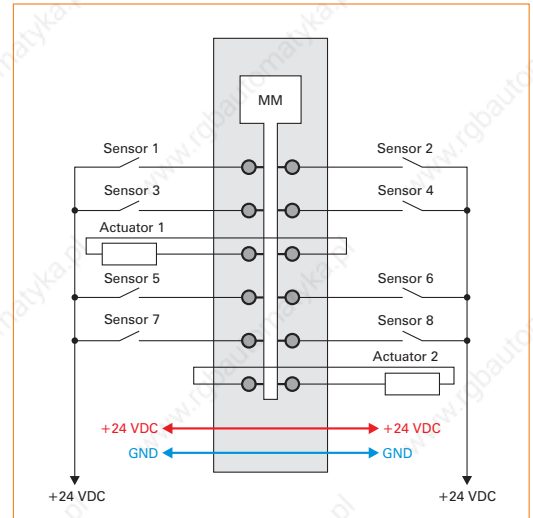

#### Required accessories

X20TB12	X20 terminal block, 12-pin, 24 V coded	94
0TB3103-7020	Accessory terminal block, 3-pin, screw clamp 6 mm <sup>2</sup>	678

## Stepper motor module SM1426



The stepper motor module SM1426 is used for controlling a stepper motor with a rated voltage of 24 VDC at a motor rated current of 1 A (maximum current 1.2 A for 2 s).

The module can resolve each full step into up to 256 microsteps. The module always carries out the maximum number of microsteps possible at a particular step frequency. On the one hand this increases the positioning precision, and on the other it makes operation much smoother. This considerably reduces the resonance effects common to stepper motors.

- Stepper motor control for motors with 24 VDC and 1 A (max. 1.2 A for 2 s)
- 256 microsteps per step
- Four inputs for limit switches or ABR incremental encoder
- Holding, boost and continuous current can be defined independent of one another
- Automatic motor detection
- Stall detection

<b>Short description</b>	<b>X20SM1426</b>
I/O module	1 full bridge for controlling stepper motors
<b>Digital inputs</b>	<b>X20SM1426</b>
Number of channels	4
Rated voltage	24 VDC
Input filter	
Hardware	< 5 $\mu$ s
Software	-
Connection type	1-line connections
Input circuit	Sink
Additional functions for inputs	1x ABR incremental encoder
<b>ABR incremental encoder</b>	<b>X20SM1426</b>
Amount	1
Encoder inputs	24 V, asymmetrical
Counter size	16-bit
Input frequency (max.)	50 kHz
Evaluation	4x
<b>Motor bridge - power element</b>	<b>X20SM1426</b>
Amount	1
Rated voltage	24 VDC
Rated current	1.0 A
Maximum current	1.2 A (2 s)
Controller frequency	38.4 kHz
Step resolution	Max. 256 microsteps per step
<b>General information</b>	<b>X20SM1426</b>
Status indicators	I/O function per channel, operating state, module status
Diagnostics	
Module run/error	Yes, with status LED and software status
Output	Yes, with status LED and software status
I/O supply	Yes, with software status
Electrical isolation	
Channel - Bus	Yes
Channel - Channel	No
Power consumption	
Bus	0.01 W
I/O internal	1.8 W
Certification	CE, C-UL-US, GOST-R
<b>Operational conditions</b>	<b>X20SM1426</b>
Operating temperature	
Horizontal installation	0°C to +50°C
Relative humidity	5 to 95%, non-condensing
Mounting orientation	Horizontal
Installation at altitudes above sea level	
0 - 2000 m	No derating
>2000 m	Reduction of ambient temperature by 0.5°C per 100 m
Protection type	IP20

<b>Storage and transport conditions</b>	<b>X20SM1426</b>
Temperature	-25°C to +70°C
Relative humidity	5 to 95%, non-condensing
<b>Mechanical characteristics</b>	<b>X20SM1426</b>
Spacing	12.5 <sup>+0.2</sup> mm
Comment	Order terminal block 1x X20TB12 separately Order bus module 1x X20BM11 separately

### Pin assignments

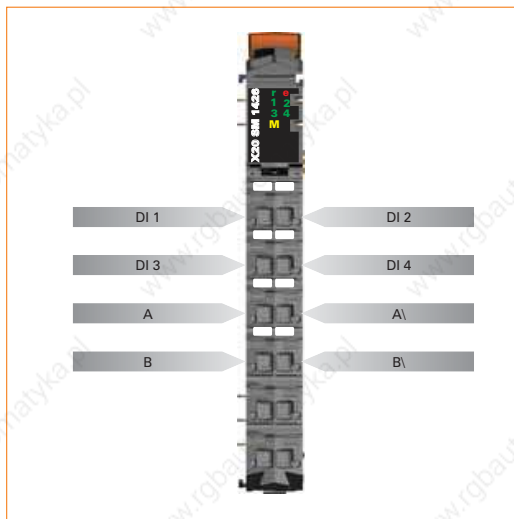

### Connection example

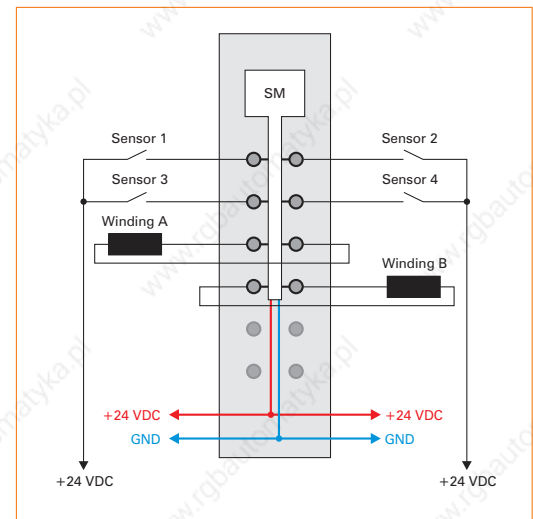

Required accessories		
X20TB12	X20 terminal block, 12-pin, 24 V coded	94
X20BM11	X20 bus module, 24 V coded, internal I/O supply is interconnected	88

# Stepper motor module SM1436



The stepper motor module SM1436 is used for controlling a stepper motor with a rated voltage of 24 VDC to 39 VDC  $\pm 25\%$  at a motor rated current of 3 A (maximum current 3.5 A for 2 s). The module supply is fed directly to the module. An additional supply module is not needed.

The module can resolve each full step into up to 256 microsteps. The module always carries out the maximum number of microsteps possible at a particular step frequency. On the one hand this increases the positioning precision, and on the other it makes operation much smoother. This considerably reduces the resonance effects common to stepper motors.

- Stepper motor control for motors with 24 VDC to 39 VDC  $\pm 25\%$  and 3 A (max. 3.5 A for 2 s)
- 256 microsteps per step
- Four inputs for limit switches or ABR incremental encoder
- Holding, boost and continuous current can be defined independent of one another
- Automatic motor detection
- Stall detection
- Power feed integrated in the module

<b>Short description</b>	<b>X20SM1436</b>
I/O module	1 full bridge for controlling stepper motors
<b>Digital inputs</b>	<b>X20SM1436</b>
Number of channels	4
Rated voltage	24 VDC
Input filter	
Hardware	< 5 $\mu$ s
Software	-
Connection type	1-line connections
Input circuit	Sink
Additional functions for inputs	1x ABR incremental encoder
<b>ABR incremental encoder</b>	<b>X20SM1436</b>
Amount	1
Encoder inputs	24 V, asymmetrical
Counter size	16-bit
Input frequency (max.)	50 kHz
Evaluation	4x
<b>Motor bridge - power element</b>	<b>X20SM1436</b>
Amount	1
Rated voltage	24 VDC - 39 VDC ( $\pm 25\%$ )
Rated current	3.0 A
Maximum current	3.5 A (2 s)
Controller frequency	38.4 kHz
Step resolution	Max. 256 microsteps per step
Output protection	No reverse polarity protection for supply voltage
<b>General information</b>	<b>X20SM1436</b>
Status indicators	I/O function per channel, operating state, module status
Diagnostics	
Module run/error	Yes, with status LED and software status
Output	Yes, with status LED and software status
I/O supply	Yes, with software status
Electrical isolation	
Channel - Bus	Yes
Channel - Channel	No
Power consumption	
Bus	0.01 W
I/O internal	-
I/O external	
24 VDC	2.45 W
48 VDC	3.15 W
Certification	CE, C-UL-US, GOST-R
<b>Operational conditions</b>	<b>X20SM1436</b>
Operating temperature	
Horizontal installation	0°C to +50°C
Relative humidity	5 to 95%, non-condensing
Mounting orientation	Horizontal
Installation at altitudes above sea level	
0 - 2000 m	No derating
>2000 m	Reduction of ambient temperature by 0.5°C per 100 m
Protection type	IP20

<b>Storage and transport conditions</b>	<b>X20SM1436</b>
Temperature	-25°C to +70°C
Relative humidity	5 to 95%, non-condensing
<b>Mechanical characteristics</b>	<b>X20SM1436</b>
Spacing	25 <sup>+0.2</sup> mm
Comment	Order terminal block 1x X20TB12 separately Order bus module 1x X20BM31 separately

### Pin assignments



### Connection example

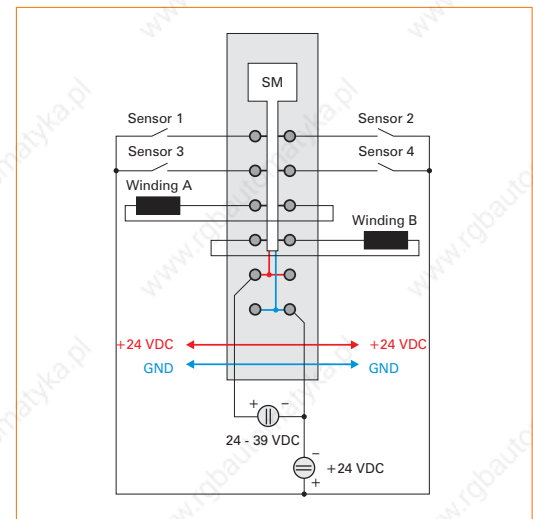

Required accessories		
X20TB12	X20 terminal block, 12-pin, 24 V coded	94
X20BM31	X20 bus module for double-width modules, internal I/O supply is interconnected	92

## Multi-measurement transformer / synchronization module CM0985



### Energy measurement and network synchronization

The CM0985 has a compact size and combines a power measurement module that has special features with a synchronization unit that is able to meet all demands.

- Energy measurement for 120 VAC to 480 VAC
- Simultaneous measurement of two AC networks plus two additional voltages
- For multifunctional measurement tasks
- Intelligent mains network synchronization unit

In the measurement unit, the three current inputs are suitable for both X:1 A and also X:5 A current transformers. The excellent overcurrent resistance as well as the high resolution of the measurement unit round off the features. For the voltage inputs, the value range can be configured between 480 VAC and 120 VAC.

The area of use includes 4-wire AC networks with a phase conductor voltage up to 480 VAC and 3-wire systems, whereas L2 can be grounded (V-connection). The module can also handle an Aron measuring circuit.

The resulting measurement values range from pure phase current and phase conductor/line voltage to active current, reactive current and apparent power components, mains frequency, power factor and much more. Additionally, peak values and work counters are saved on the module in nonvolatile memory. Depending on the configuration, a digital output with scalable rating can also be used as pulse encoder for an external energy counter.

The synchronization unit not only takes the phase position and phase voltage into consideration, built-in intelligence also takes the change speed and other parameters into consideration and allows them to influence the decision for switching the synchronization output. Monitoring of a generator is possible with a large number of additional conditions. A total of four voltage inputs provide the needed flexibility.

Monitoring functions extend the features of the module. Thermal overload protection is included, which uses the thermal capacity of the motor/generators to allow short overloads and still provides full protection. Unbalanced load monitoring, which is used to protect three-phase producers and three-phase networks from an unbalanced load, can be adjusted to the characteristics of different generator types using parameters while taking its special thermal time constants into consideration.



<b>Short description</b>	<b>X20CM0985</b>
I/O module	X20 energy measurement and mains network synchronization module
<b>Digital outputs</b>	<b>X20CM0985</b>
Channels	5
Rated voltage	24 VDC
Rated output current	0.1 A
Total current	0.5 A
Connection type	1-line connections
Output circuit	Source
Output protection	Overload protection, short circuit protection
<b>Relay outputs</b>	<b>X20CM0985</b>
Channels	1
Relay contacts	Max. 230 VAC / 0.5 A
Surge withstand capability of contacts	500 V
<b>Analog inputs - voltage</b>	<b>X20CM0985</b>
Channels	8
Input	$\pm 120 \text{ VAC} + 10\% / \pm 480 \text{ VAC} + 10\%$ (can be configured)
Digital converter resolution	16-bit
Output format	UINT
Input impedance	Approx. 3 M $\Omega$
Input filter	
Limit frequency	10 kHz
Attenuation	60 dB
Basic accuracy	0.5% <sup>1)</sup>
<sup>1)</sup> Refers to the measurement range limit	
<b>Analog inputs - current</b>	<b>X20CM0985</b>
Channels	3
Input	$\pm 1 \text{ A} / \pm 5 \text{ A}$ (can be configured)
Digital converter resolution	16-bit
Output format	UINT
Input filter	
Limit frequency	10 kHz
Attenuation	60 dB
Basic accuracy	0.5% <sup>1)</sup>
Thermal over-current	$15 \times I_{\text{rated}}$ for 0.2 s
Monitored over-current	$4 \times I_{\text{rated}}$
<sup>1)</sup> Refers to the measurement range limit	
<b>General information</b>	<b>X20CM0985</b>
Status indicators	Channel status, operating status, module status
Diagnostics	
Module run/error	Yes, with status LED and software status
Digital outputs	Yes, with status LED and software status
Analog inputs	Yes, with status LED (measurement range of analog inputs)
Electrical isolation	
Bus inputs/outputs	Yes
Digital - Analog	Yes
Bus - I/O supply	Yes
Power consumption	
Bus	1.4 W
I/O internal	4 W
Certification	CE, C-UL-US, GOST-R

## Multi-measurement transformer / synchronization module CM0985

<b>Operational conditions</b>	<b>X20CM0985</b>
Operating temperature	
Horizontal installation	0°C to +55°C
Vertical installation	0°C to +50°C
Relative humidity	5 to 95%, non-condensing
Mounting orientation	Horizontal or vertical
Installation at altitudes above sea level	
0 - 2000 m	No derating
>2000 m	Reduction of ambient temperature by 0.5°C per 100 m
Protection type	IP20
<b>Storage and transport conditions</b>	<b>X20CM0985</b>
Temperature	-25°C to +70°C
Relative humidity	5 to 95%, non-condensing
<b>Mechanical characteristics</b>	<b>X20CM0985</b>
Spacing	87.5 <sup>+0.2</sup> mm
Comment	Order terminal block 2x X20TB12 separately Order screw clamps 2x TB3102 and 2x TB3104 separately

### Digital outputs - Pin assignments

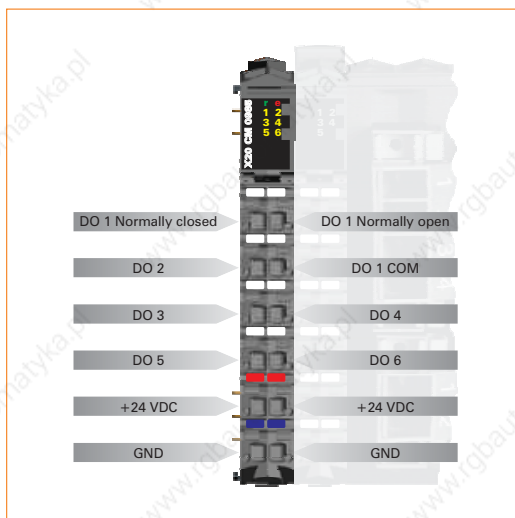

### Analog current inputs - Pin assignments

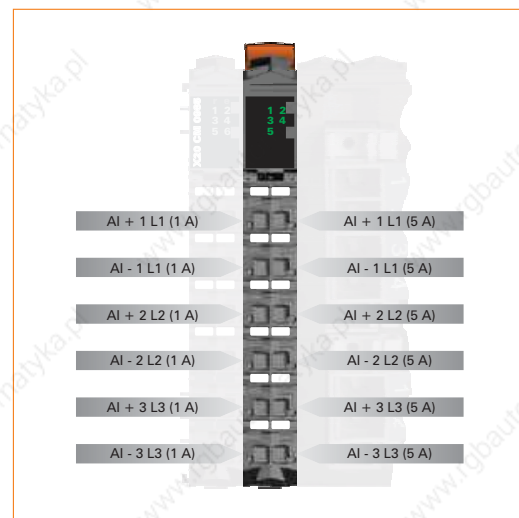

### Tension clamps X3 and X5 - Pin assignments

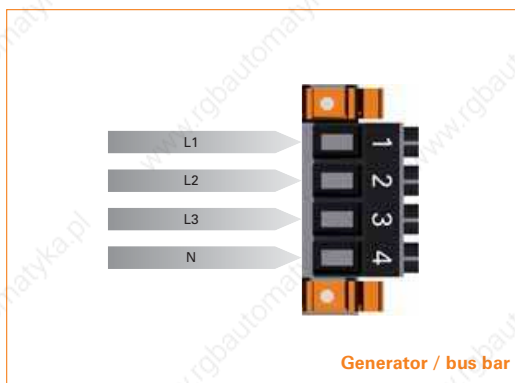

### Tension clamps X4 and X6 - Pin assignments



Required accessories		
0TB3102-7011	Accessory terminal block, 2-pin, A coded, screw clamp, 6 mm <sup>2</sup>	676
0TB3102-7012	Accessory terminal block, 2-pin, B coded, screw clamp, 6 mm <sup>2</sup>	676
0TB3104-7011	Accessory terminal block, 4-pin, A coded, screw clamp, 6 mm <sup>2</sup>	679
0TB3104-7012	Accessory terminal block, 4-pin, B coded, screw clamp, 6 mm <sup>2</sup>	679
X20TB12	X20 terminal block, 12-pin, 24 V coded	94

## Combination module CM1201



The CM1201 can be used to configure and carry out simple movements. For this purpose, the module has an AB encoder input and a total of eight digital channels. Four of them are inputs, and the other four can be set as either inputs or outputs. Various output bit patterns can be set easily in the module itself. The CM1201 is perfectly suited for easy to create drive control tasks for program and event controlled motor movements. Feed movements using drives with two speeds and forward/reverse movement are created easily and efficiently.

- Command dependent digital output patterns
- Counter dependent output switch
- Event controlled abort criteria
- 4 digital inputs
- 4 digital channels, can be configured as inputs or outputs

<b>Short description</b>	<b>X20CM1201</b>
I/O module	1 AB incremental encoder, 24 V, 4 digital inputs, 4 channels can be configured as inputs or outputs
<b>AB incremental encoders</b>	<b>X20CM1201</b>
Amount	1
Encoder inputs	24 V, asymmetrical
Counter size	32-bit
Input frequency (max.)	100 kHz
Evaluation	4x
Encoder supply	Module-internal, max. 600 mA
<b>Digital inputs</b>	<b>X20CM1201</b>
Amount	4 + 4 additional channels, can be configured as input or output
Rated voltage	24 VDC
Input filter	
Hardware	≤2 μs
Software	-
Connection type	1-line connections
Input circuit	Sink
<b>Digital outputs</b>	<b>X20CM1201</b>
Amount	Up to 4, configuration as input or output takes place using software
Rated voltage	24 VDC
Rated output current	0.1 A
Total current	0.4 A
Connection type	1-line connections
Output circuit	Sink or source
Output protection	Thermal cutoff for overcurrent and short circuit, integrated protection for switching inductances
Actuator supply	Module-internal, max. 600 mA
<b>General information</b>	<b>X20CM1201</b>
Status indicators	I/O function per channel, operating state, module status
Diagnostics	
Module run/error	Yes, with status LED and software status
Outputs	Yes, with status LED and software status (output status)
Electrical isolation	
Channel - Bus	Yes
Channel - Channel	No
Power consumption	
Bus	0.01 W
I/O internal	1.5 W
Certification	CE, C-UL-US, GOST-R
<b>Operational conditions</b>	<b>X20CM1201</b>
Operating temperature	
Horizontal installation	0°C to +55°C
Vertical installation	0°C to +50°C
Relative humidity	5 to 95%, non-condensing
Mounting orientation	Horizontal or vertical
Installation at altitudes above sea level	
0 - 2000 m	No derating
>2000 m	Reduction of ambient temperature by 0.5°C per 100 m
Protection type	IP20

<b>Storage and transport conditions</b>	<b>X20CM1201</b>
Temperature	-25°C to +70°C
Relative humidity	5 to 95%, non-condensing
<b>Mechanical characteristics</b>	<b>X20CM1201</b>
Spacing	12.5 <sup>+0.2</sup> mm
Comment	Order terminal block 1x X20TB12 separately Order bus module 1x X20BM11 separately

### Pin assignments

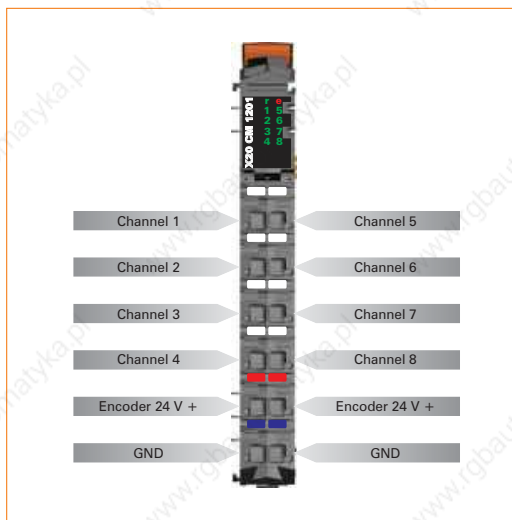

### Connection example

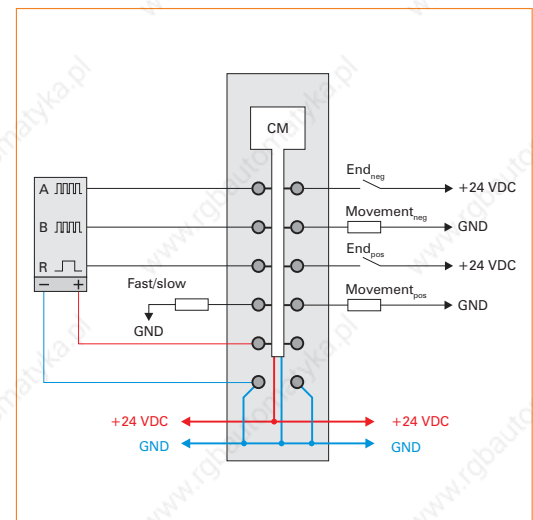

Required accessories		
X20TB12	X20 terminal block, 12-pin, 24 V coded	94
X20BM11	X20 bus module, 24 V coded, internal I/O supply is interconnected	88

# Universal mixed module CM8281



- Digital and analog channels
- Selectable current and voltage for AI and AO
- Counter functions

<b>Short description</b>	<b>X20CM8281</b>	
I/O module	4 digital inputs, 2 digital outputs, 1 analog input, 1 analog output, special functions	
<b>Digital inputs</b>	<b>X20CM8281</b>	
Number of channels	4	
Rated voltage	24 VDC	
Input filter		
Hardware	≤2 μs	
Software	Default 1 ms, can be configured between 0 and 25 ms in 0.2 ms intervals	
Connection type	1-line connections	
Input circuit	Sink	
Additional functions for inputs	20 kHz event counting, gate measurement	
<b>Digital outputs</b>	<b>X20CM8281</b>	
Number of channels	2	
Rated voltage	24 VDC	
Rated output current	0.5 A	
Total current	1.0 A	
Connection type	1-line connections	
Output circuit	Source	
Output protection	Thermal cutoff for overcurrent or short circuit, integrated protection for switching inductances, reverse polarity protection	
<b>Analog inputs</b>	<b>Voltage</b>	<b>Current</b>
Number of channels	1	
Input	±10 V or 0 to 20 mA/4 to 20 mA, using different connection terminal points	
Input type	Single ended	
Digital converter resolution	±12-bit	12-bit
Conversion time	400 μs, conversion runs asynch. to X2X Link cycle	
Output format	UINT	
Input impedance in signal range	>1 MΩ	-
Load	-	<300 Ω
Maximum error at 25°C		
Gain	0.03% <sup>1)</sup>	0 to 20 mA = 0.065% <sup>1)</sup> / 4 to 20 mA = 0.0813% <sup>1)</sup>
Offset	0.01% <sup>2)</sup>	0 to 20 mA = 0.02% <sup>3)</sup> / 4 to 20 mA = 0.025% <sup>3)</sup>
Input protection	Protection against wiring with supply voltage	
1) Based on the current measurement value.		
2) Based on the 20 V measurement range.		
3) Based on the 20 mA measurement range.		
<b>Analog outputs</b>	<b>X20CM8281</b>	
Number of channels	1	
Output	±10 V or 0 to 20 mA, using different connection terminal points	
Digital converter resolution	12-bit	
Conversion time	300 μs, conversion runs asynchronous to the X2X Link cycle	
Power on/off behavior	Internal enable relay for boot procedure and errors	
Maximum error at 25°C		
Gain	0.04% <sup>1)</sup>	0.05% <sup>1)</sup>
Offset	0.0225% <sup>2)</sup>	0.0125% <sup>2)</sup>
Output protection	Short circuit protection	
1) Based on the current output value.		
2) Based on the entire output range.		

<b>General information</b>	<b>X20CM8281</b>
Status indicators	I/O function per channel, operating state, module status
<b>Diagnostics</b>	
Module run/error	Yes, with status LED and software status
Digital outputs	Yes, with status LED and software status (output error status)
Analog inputs	Yes, with status LED and software status
<b>Electrical isolation</b>	
Channel - Bus	Yes
Channel - Channel	No
<b>Power consumption</b>	
Bus	0.01 W
I/O internal	1.75 W
Certification	CE, C-UL-US, GOST-R
<b>Operational conditions</b>	<b>X20CM8281</b>
<b>Operating temperature</b>	
Horizontal installation	0°C to +55°C
Vertical installation	0°C to +50°C
Relative humidity	5 to 95%, non-condensing
Mounting orientation	Horizontal or vertical
<b>Installation at altitudes above sea level</b>	
0 - 2000 m	No derating
>2000 m	Reduction of ambient temperature by 0.5°C per 100 m
Protection type	IP20
<b>Storage and transport conditions</b>	<b>X20CM8281</b>
Temperature	-25°C to +70°C
Relative humidity	5 to 95%, non-condensing
<b>Mechanical characteristics</b>	<b>X20CM8281</b>
Spacing	12.5 <sup>+0.2</sup> mm
Comment	Order terminal block 1x X20TB12 separately Order bus module 1x X20BM11 separately

# Universal mixed module CM8281

## Pin assignments

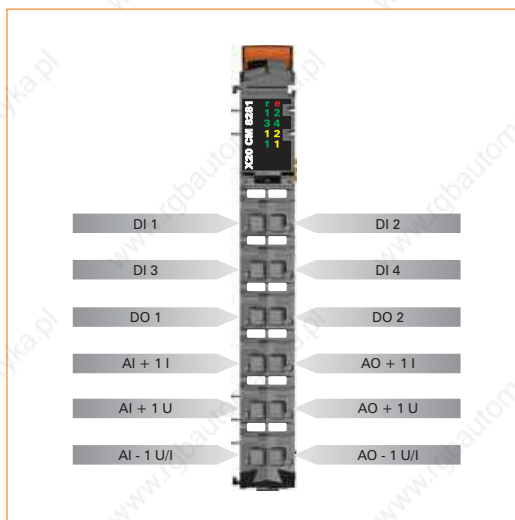

## Connection example

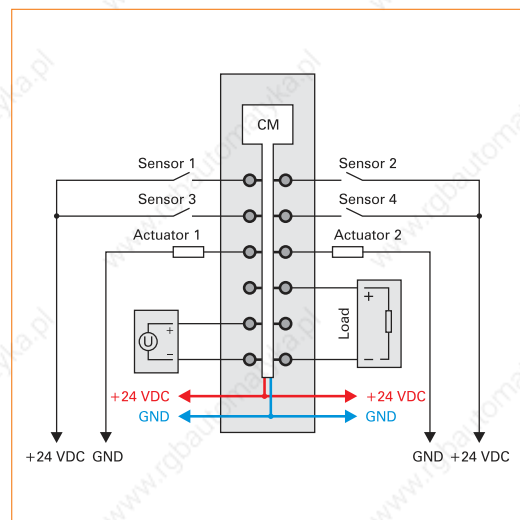

### Required accessories

X20TB12	X20 terminal block, 12-pin, 24 V coded	94
X20BM11	X20 bus module, 24 V coded, internal I/O supply is interconnected	88



## PWM module with current monitoring CM8323



- 8 digital outputs
- Current trace
- Switching time detection
- Pulse width modulation

<b>Short description</b>	<b>X20CM8323</b>
I/O module	8 digital outputs for switching electromechanical loads, current trace, switching time detection, pulse width modulation
<b>Digital outputs</b>	<b>X20CM8323</b>
Rated voltage	24 VDC
Rated output current	0.6 A
Starting current	Max. 2.0 A
Total current	4.8 A
Connection type	1-line connections
Output circuit	Sink
Output protection	Thermal cutoff for overcurrent or short circuit, integrated protection for switching inductances
Braking Voltage when Switching Off	39 VDC
<b>General information</b>	<b>X20CM8323</b>
Status indicators	I/O function per channel, operating state, module status
<b>Diagnostics</b>	
Module run/error	Yes, with status LED and software status
Outputs	Yes, with status LED and software status (output error status)
<b>Electrical isolation</b>	
Channel - Bus	Yes
Channel - Module supply	No
Channel - Channel	No
<b>Power consumption</b>	
Bus	0.01 W
I/O internal	1.5 W
Certification	CE, C-UL-US, GOST-R
<b>Operational conditions</b>	<b>X20CM8323</b>
<b>Operating temperature</b>	
Horizontal installation	0°C to +55°C
Vertical installation	0°C to +50°C
Relative humidity	5 to 95%, non-condensing
Mounting orientation	Horizontal or vertical
<b>Installation at altitudes above sea level</b>	
0 - 2000 m	No derating
>2000 m	Reduction of ambient temperature by 0.5°C per 100 m
Protection type	IP20
<b>Storage and transport conditions</b>	<b>X20CM8323</b>
Temperature	-25°C to +70°C
Relative humidity	5 to 95%, non-condensing
<b>Mechanical characteristics</b>	<b>X20CM8323</b>
Spacing	12.5 <sup>+0.2</sup> mm
Comment	Order terminal block 1x X20TB12 separately Order bus module 1x X20BM11 separately

## Pin assignments

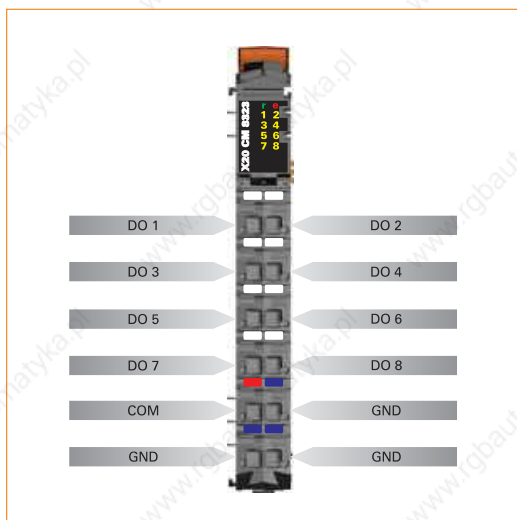

## Connection example

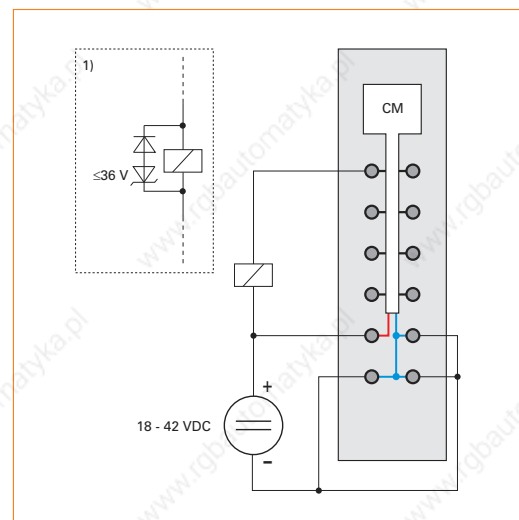

1) If larger inductances or more current are used; the "transil-diode combination" must be placed externally on the relay/valve.

### Required accessories

X20TB12	X20 terminal block, 12-pin, 24 V coded	94
X20BM11	X20 bus module, 24 V coded, internal I/O supply is interconnected	88

# Potential distributor module PD0011



The PD0011 potential distributor module provides 12 ground connections (from the internal I/O supply) at the terminals, which opens up additional wiring possibilities for sensors and actuators. The module is equipped with an exchangeable microfuse between the GND potential on the terminal block and the X20 System I/O supply. The function of the fuse is monitored.

- Integrated exchangeable microfuse
- Monitoring of the fuse
- Potential for routing as needed

**Note:**  
The wired load must be supplied with 24 VDC.

<b>Short description</b>	<b>X20PD0011</b>
Potential distributor module	12x ground on the terminal points
<b>Output I/O supply</b>	<b>X20PD0011</b>
Rated output voltage	Ground from the internal I/O supply
Fuse	Integrated T 6.3 A, exchangeable
Permitted contact load	10.0 A
<b>General information</b>	<b>X20PD0011</b>
Status indicators	Operating status, module status
<b>Diagnostics</b>	
Module run/error	Yes, with status LED and software status
Fuse monitoring	Yes, with status LED and software status
<b>Power consumption <sup>1)</sup></b>	
Bus	0.12 W
I/O internal	-
I/O external	1.0 W
Certification	CE, C-UL-US (in development), GOST-R
<small>1) The specified values are maximum values. The exact calculation is available for download as a data sheet with the other module documentation on the B&amp;R homepage.</small>	
<b>Operational conditions</b>	<b>X20PD0011</b>
<b>Operating temperature</b>	
Horizontal installation	0°C to +55°C
Vertical installation	0°C to +50°C
Relative humidity	5 to 95%, non-condensing
Mounting orientation	Horizontal or vertical
<b>Installation at altitudes above sea level</b>	
0 - 2000 m	No derating
>2000 m	Reduction of ambient temperature by 0.5°C per 100 m
Protection type	IP20
<b>Storage and transport conditions</b>	<b>X20PD0011</b>
Temperature	-25°C to +70°C
Relative humidity	5 to 95%, non-condensing
<b>Mechanical characteristics</b>	<b>X20PD0011</b>
Spacing	12.5 <sup>+0.2</sup> mm
Comment	Order terminal block 1x X20TB12 separately Order bus module 1x X20BM11 separately

### Pin assignments

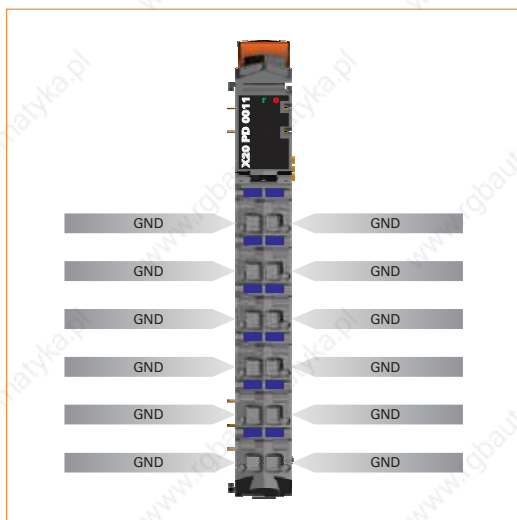

### Connection example

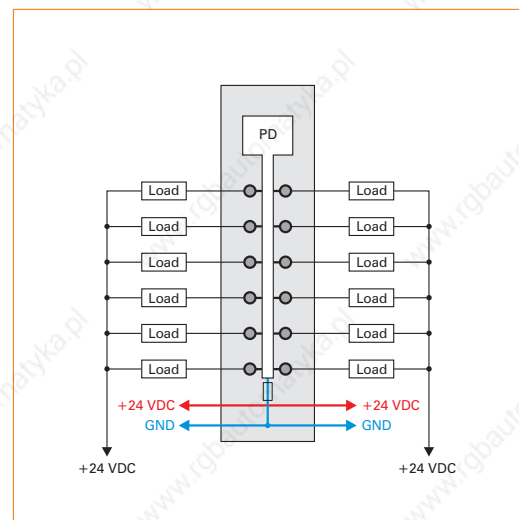

#### Required accessories

X20TB12	X20 terminal block, 12-pin, 24 V coded	94
X20BM11	X20 bus module, 24 V coded, internal I/O supply is interconnected	88

# Potential distributor module PD0012



The PD0012 potential distributor module provides twelve 24 VDC connections (from the internal I/O supply) at the terminals, which opens up additional wiring possibilities for sensors and actuators. The module is equipped with an exchangeable microfuse between the 24 VDC potential on the terminal block and the X20 System I/O supply. The function of the fuse is monitored.

- Integrated exchangeable microfuse
- Monitoring of the fuse
- Potential for routing as needed

<b>Short description</b>	<b>X20PD0012</b>
Potential distributor module	12x 24 VDC on the terminals
<b>Output I/O supply</b>	<b>X20PD0012</b>
Rated output voltage	24 VDC from the internal I/O supply
Fuse	Integrated T 6.3 A, exchangeable
Permitted contact load	10.0 A
<b>General information</b>	<b>X20PD0012</b>
Status indicators	Operating status, module status
<b>Diagnostics</b>	
Module run/error	Yes, with status LED and software status
Fuse monitoring	Yes, with status LED and software status
<b>Power consumption <sup>1)</sup></b>	
Bus	0.12 W
I/O internal	1.0 W
Certification	CE, C-UL-US (in development), GOST-R
1) The specified values are maximum values. The exact calculation is available for download as a data sheet with the other module documentation on the B&R homepage.	
<b>Operational conditions</b>	<b>X20PD0012</b>
<b>Operating temperature</b>	
Horizontal installation	0°C to +55°C
Vertical installation	0°C to +50°C
Relative humidity	5 to 95%, non-condensing
Mounting orientation	Horizontal or vertical
<b>Installation at altitudes above sea level</b>	
0 - 2000 m	No derating
>2000 m	Reduction of ambient temperature by 0.5°C per 100 m
Protection type	IP20
<b>Storage and transport conditions</b>	<b>X20PD0012</b>
Temperature	-25°C to +70°C
Relative humidity	5 to 95%, non-condensing
<b>Mechanical characteristics</b>	<b>X20PD0012</b>
Spacing	12.5 <sup>+0.2</sup> mm
Comment	Order terminal block 1x X20TB12 separately Order bus module 1x X20BM11 separately

### Pin assignments

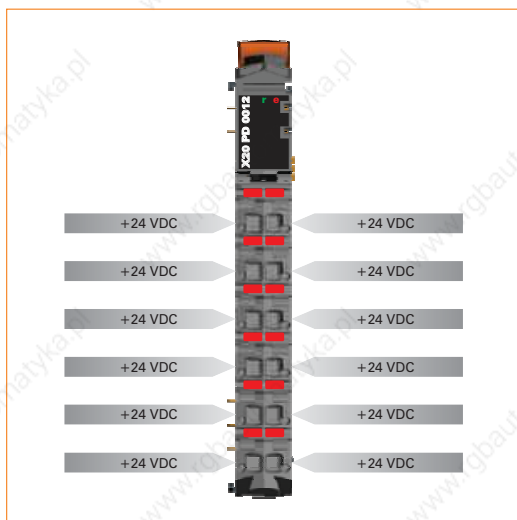

### Connection example

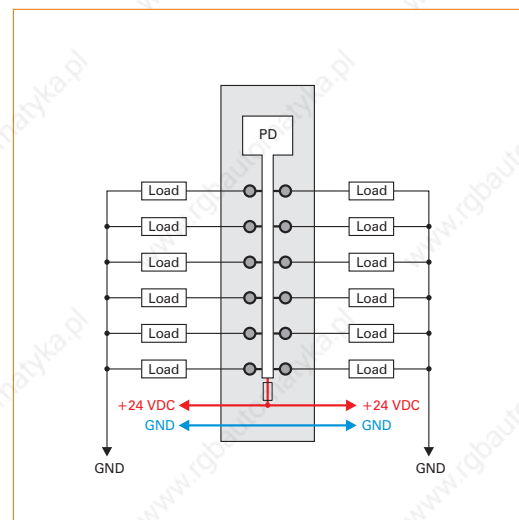

#### Required accessories

X20TB12	X20 terminal block, 12-pin, 24 V coded	94
X20BM11	X20 bus module, 24 V coded, internal I/O supply is interconnected	88

## Potential distributor module PD0016



The PD0016 potential distributor module provides 5x 24 VDC and 5x ground connections (from an external supply) at the terminals. There is no connection to the internal I/O supply, so this module only serves to distribute an external supply for the load and electronics supply. The externally fed 24 VDC supply is provided on the terminal points through an exchangeable microfuse. The 24 VDC feed and the function of the fuse are monitored.

- Integrated exchangeable microfuse
- Monitoring of the fuse
- Potential for routing as needed
- Distribution of the load and electronics supply
- Isolation from the internal I/O supply

<b>Short description</b>	<b>X20PD0016</b>
Potential distributor module	5 x 24 VDC on the terminal points, 5 x ground on the terminal points
<b>Input supply</b>	<b>X20PD0016</b>
Nominal input voltage	24 VDC (-15% / +20%) external, external ground
Fuse	Integrated T 6.3 A, exchangeable
<b>output supply.</b>	<b>X20PD0016</b>
Rated output voltage	24 VDC, ground
Permitted contact load	10.0 A
<b>General information</b>	<b>X20PD0016</b>
Status indicators	Operating status, module status
Diagnostics	
Module run/error	Yes, with status LED and software status
Fuse monitoring	Yes, with status LED and software status
Power consumption <sup>1)</sup>	
Bus	0.12 W
I/O internal	-
I/O external	1.15 W
Certification	CE, C-UL-US (in development), GOST-R
<small>1) The specified values are maximum values. The exact calculation is available for download as a data sheet with the other module documentation on the B&amp;R homepage.</small>	
<b>Operational conditions</b>	<b>X20PD0016</b>
Operating temperature	
Horizontal installation	0°C to +55°C
Vertical installation	0°C to +50°C
Relative humidity	5 to 95%, non-condensing
Mounting orientation	Horizontal or vertical
Installation at altitudes above sea level	
0 - 2000 m	No derating
>2000 m	Reduction of ambient temperature by 0.5°C per 100 m
Protection type	IP20
<b>Storage and transport conditions</b>	<b>X20PD0016</b>
Temperature	-25°C to +70°C
Relative humidity	5 to 95%, non-condensing
<b>Mechanical characteristics</b>	<b>X20PD0016</b>
Spacing	12.5 <sup>+0.2</sup> mm
Comment	Order terminal block 1x X20TB12 separately Order bus module 1x X20BM11 separately

### Pin assignments

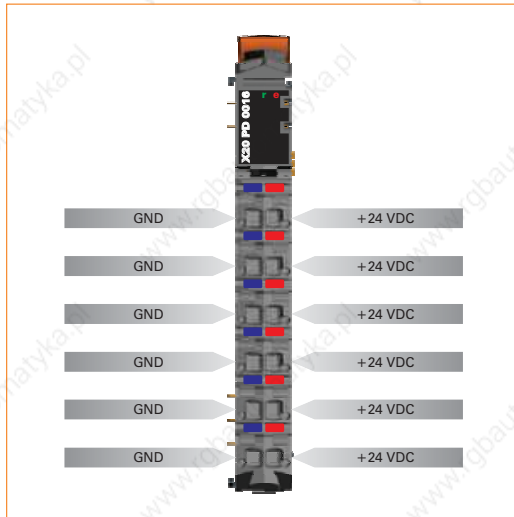

### Connection example

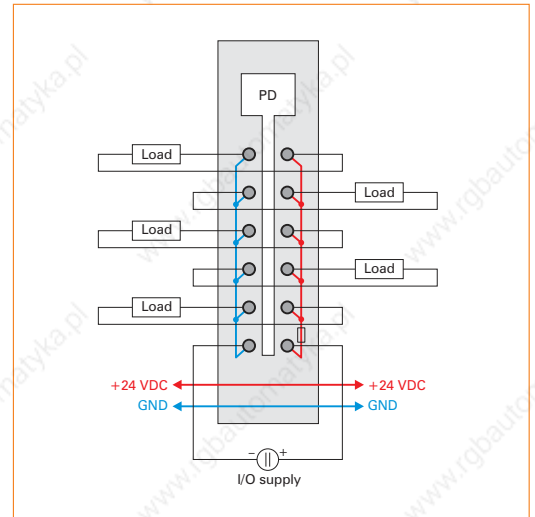

#### Required accessories

X20TB12	X20 terminal block, 12-pin, 24 V coded	94
X20BM11	X20 bus module, 24 V coded, internal I/O supply is interconnected	88

# Potential distributor module PD2113



The PD2113 potential distributor module with feed can provide 6x 24 VDC and 6x ground connections from the internal I/O supply on the terminals. This module can also be used instead of a special feed module for the internal I/O supply. The internal 24 VDC supply is protected through an exchangeable microfuse to the terminal points. The 24 VDC feed and the function of the fuse are monitored.

- Integrated exchangeable microfuse
- Monitoring of the fuse
- Potential for routing as needed
- Can be used as feed module for the I/O supply

#### Note:

Because the 6x 24 VDC terminals are connected together and the fuse is between the terminal points and the internal I/O supply, the terminal potentials do not have short-circuit protection if an external feed is used. Therefore the respective 24 VDC terminal points must be protected with an external fuse if an external feed is used. A BM01 bus module should be used in this situation.

<b>Short description</b>	<b>X20PD2113</b>
Potential distributor module with feed	6x 24 VDC on the terminals, 6x ground on the terminals
<b>Input supply with feed</b>	<b>X20PD2113</b>
Nominal input voltage	24 VDC (-15% / +20%) external, external ground
Fuse	Integrated T 6.3 A, exchangeable
<b>Output I/O supply</b>	<b>X20PD2113</b>
Rated output voltage	24 VDC, ground
Permitted contact load	10.0 A
Fuse	Integrated T 6.3 A, exchangeable
<b>General information</b>	<b>X20PD2113</b>
Status indicators	Operating status, module status
<b>Diagnostics</b>	
Module run/error	Yes, with status LED and software status
Fuse monitoring	Yes, with status LED and software status
<b>Power consumption <sup>1)</sup></b>	
Bus	0.12 W
I/O internal	-
I/O external	1.15 W
Certification	CE, C-UL-US (in development), GOST-R
<small>1) The specified values are maximum values. The exact calculation is also available for download as a data sheet with the other module documentation on the B&amp;R homepage.</small>	
<b>Operational conditions</b>	<b>X20PD2113</b>
<b>Operating temperature</b>	
Horizontal installation	0°C to +55°C
Vertical installation	0°C to +50°C
Relative humidity	5 to 95%, non-condensing
Mounting orientation	Horizontal or vertical
<b>Installation at altitudes above sea level</b>	
0 - 2000 m	No derating
> 2000 m	Reduction of ambient temperature by 0.5°C per 100 m
Protection type	IP20
<b>Storage and transport conditions</b>	<b>X20PD2113</b>
Temperature	-25°C to +70°C
Relative humidity	5 to 95%, non-condensing
<b>Mechanical characteristics</b>	<b>X20PD2113</b>
Spacing	12.5 <sup>+0.2</sup> mm
Comment	Order terminal block 1x X20TB12 separately Order bus module 1x X20BM01 or X20BM11 separately

### Pin assignments

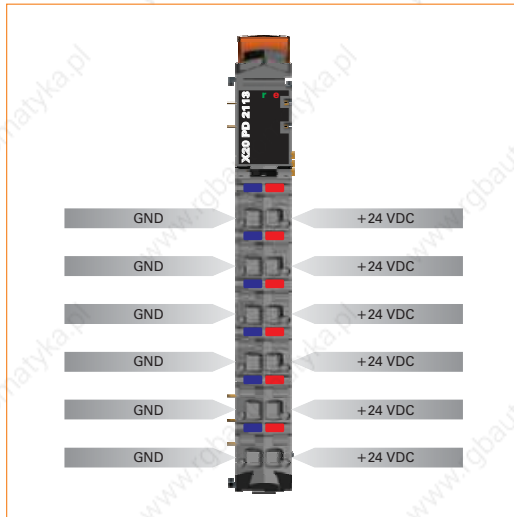

### Connection example with external supply

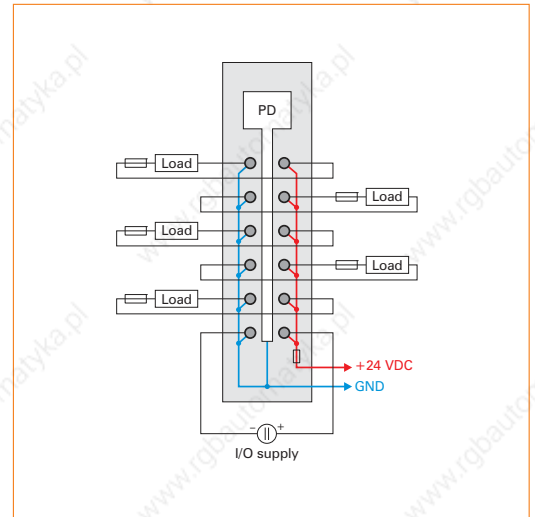

Required accessories		
X20TB12	X20 terminal block, 12-pin, 24 V coded	▮ 94
X20BM01	X20 supply bus module, internal I/O supply is isolated to the left	▮ 86
X20BM11	X20 bus module, 24 V coded, internal I/O supply is interconnected	▮ 88

# Potentiometer supply module PS4951



To connect a potentiometer, you need a module with the right power supply. The potentiometer supply module PS4851 can be used to supply four potentiometers with  $\pm 10$  V. The values are evaluated using standard analog input modules.

- Open connection and short-circuit detection
- Simple implementation of potentiometer inputs
- 4x supply

<b>Short description</b>	<b>X20PS4951</b>
System module	Supply of four potentiometers with $\pm 10$ V
<b>Potentiometer supply</b>	<b>X20PS4951</b>
Number of supplies	4
Voltage	$\pm 10$ V
Potentiometer resistance	1 k $\Omega$ to 10 k $\Omega$
Load	Max. 20 mA per supply channel
Short circuit protection	Yes
Basic accuracy	
+10 V	$\pm 0.12\%$ at 25°C
-10 V	$\pm 0.21\%$ at 25°C
<b>General information</b>	<b>X20PS4951</b>
Status indicators	Potentiometer supply monitoring by channel, operating status, module status
Diagnostics	
Module run/error	Yes, with status LED and software status
Overload	Yes, with status LED and software status
Wire break	Yes, with status LED and software status
Electrical isolation	
Channel - Bus	Yes
Channel - Channel	No
Power consumption	
Bus	0.01 W
I/O internal	1.8 W
Certification	CE, C-UL-US, GOST-R
<b>Operational conditions</b>	<b>X20PS4951</b>
Operating temperature	
Horizontal installation	0°C to +55°C
Vertical installation	Values derated when mounted vertically
Relative humidity	5 to 95%, non-condensing
Mounting orientation	Horizontal or vertical
Installation at altitudes above sea level	
0 - 2000 m	No derating
>2000 m	Reduction of ambient temperature by 0.5°C per 100 m
Protection type	IP20
<b>Storage and transport conditions</b>	<b>X20PS4951</b>
Temperature	-25°C to +70°C
Relative humidity	5 to 95%, non-condensing
<b>Mechanical characteristics</b>	<b>X20PS4951</b>
Spacing	12.5 <sup>+0.2</sup> mm
Comment	Order terminal block 1x X20TB12 separately Order bus module 1x X20BM11 separately

### Pin assignments

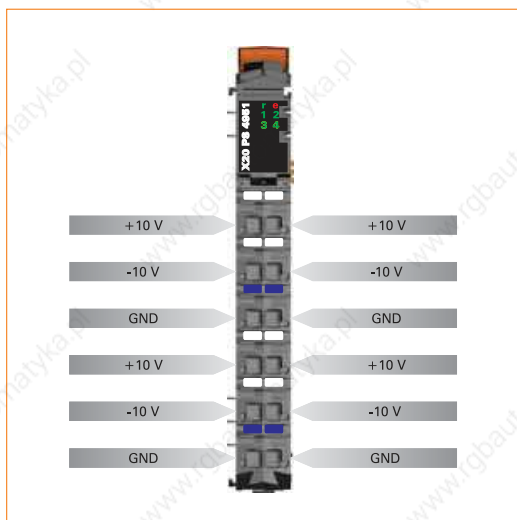

### Connection example

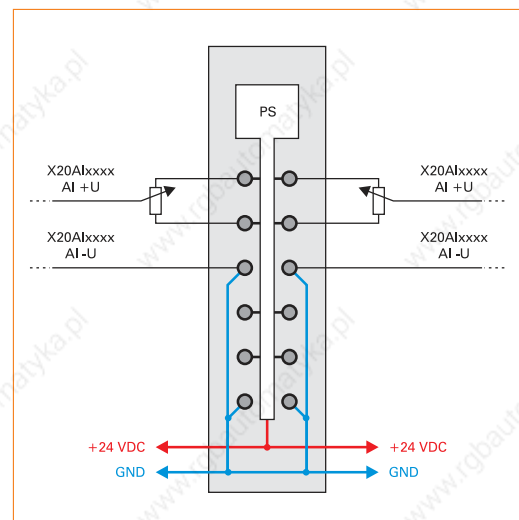

#### Required accessories

X20TB12	X20 terminal block, 12-pin, 24 V coded	94
X20BM11	X20 bus module, 24 V coded, internal I/O supply is interconnected	88

## Resolver interface with ABR output CM1941



- Resolver input (differential), with angular position and cyclic counter
- 14-bit resolution for the angular position
- ABR output (configurable)

<b>Short description</b>	<b>X20CM1941</b>
I/O module	1 resolver input, 1 ABR output
<b>Resolver input</b>	<b>X20CM1941</b>
Resolver gear ratio	0.5 (± 10%)
Frequency (reference output)	10 kHz
Type	Differential
Angular position resolution	14-bit
Short circuit protection (reference output)	Yes
<b>ABR output</b>	<b>X20CM1941</b>
Encoder signal	RS422
Type	ABR differential
ABR output (up to Firmware version 4)	Configurable
8-bit	Max. 2343 revolutions
9-bit	Max. 1171 revolutions
10-bit	Max. 585 revolutions
ABR output (starting at Firmware version 5)	
8-bit ... 12-bit	3500 revolutions
Short circuit protection (reference output)	Yes
<b>General information</b>	<b>X20CM1941</b>
Status indicators	Input, output, operating status, module status
Diagnostics	
Module run/error	Yes, with status LED and software status
Resolver input (OK, wire break)	Yes, with status LED and software status
Resolver input (counter direction)	Yes, with status LED and software status
Electrical isolation	
Input/output bus	Yes
Input/output - module supply	No
Channel - Channel	No
Power consumption	
Bus	0.01 W
I/O internal	1.5 W
Certification	CE, C-UL-US, GOST-R
<b>Operational conditions</b>	<b>X20CM1941</b>
Operating temperature	
Horizontal installation	0°C to +55°C
Vertical installation	0°C to +50°C
Relative humidity	5 to 95%, non-condensing
Mounting orientation	Horizontal or vertical
Installation at altitudes above sea level	
0 - 2000 m	No derating
>2000 m	Reduction of ambient temperature by 0.5°C per 100 m
Protection type	IP20
<b>Storage and transport conditions</b>	<b>X20CM1941</b>
Temperature	-25°C to +70°C
Relative humidity	5 to 95%, non-condensing
<b>Mechanical characteristics</b>	<b>X20CM1941</b>
Spacing	12.5 <sup>+0.2</sup> mm
Comment	Order terminal block 1x X20TB12 separately Order bus module 1x X20BM11 separately

### Pin assignments



### Connection example

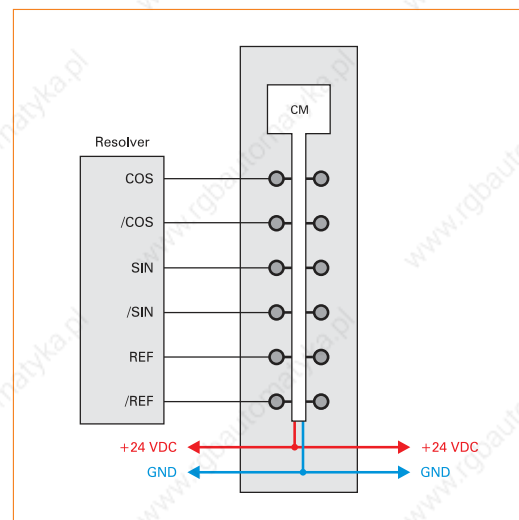

#### Required accessories

X20TB12	X20 terminal block, 12-pin, 24 V coded	94
X20BM11	X20 bus module, 24 V coded, internal I/O supply is interconnected	88

# Counter module DC1196



- One 5 V ABR incremental encoder
- 2 additional inputs e.g. for reference enable switch
- 5 VDC, 24 VDC and GND for Encoder supply

<b>Short description</b>	<b>X20DC1196</b>
I/O module	One 5 V ABR incremental encoder
<b>ABR incremental encoder</b>	<b>X20DC1196</b>
Encoder inputs	5 V, symmetrical
Counter size	16/32-bit
Input frequency (max.)	250 kHz
Evaluation	4x
Encoder supply	
5 V	Module-internal, max. 300 mA
24 V	Module-internal, max. 300 mA
<b>Digital inputs</b>	<b>X20DC1196</b>
Amount	2
Rated voltage	24 VDC
Input filter	
Hardware	≤2 μs
Software	-
Connection type	3-line connections
Input circuit	Sink
Additional functions	Reference enable switch
<b>General information</b>	<b>X20DC1196</b>
Status indicators	I/O function per channel, operating state, module status
Diagnostics	
Module run/error	Yes, with status LED and software status
Electrical isolation	
Encoder - Bus	Yes
Channel - Bus	Yes
Channel - Encoder	No
Channel - Channel	No
Power consumption	
Bus	0.01 W
I/O internal	1.5 W
Certification	CE, C-UL-US, GOST-R
<b>Operational conditions</b>	<b>X20DC1196</b>
Operating temperature	
Horizontal installation	0°C to +55°C
Vertical installation	0°C to +50°C
Relative humidity	5 to 95%, non-condensing
Mounting orientation	Horizontal or vertical
Installation at altitudes above sea level	
0 - 2000 m	No derating
>2000 m	Reduction of ambient temperature by 0.5°C per 100 m
Protection type	IP20
<b>Storage and transport conditions</b>	<b>X20DC1196</b>
Temperature	-25°C to +70°C
Relative humidity	5 to 95%, non-condensing
<b>Mechanical characteristics</b>	<b>X20DC1196</b>
Spacing	12.5 <sup>+0.2</sup> mm
Comment	Order terminal block 1x X20TB12 separately Order bus module 1x X20BM11 separately

## Pin assignments

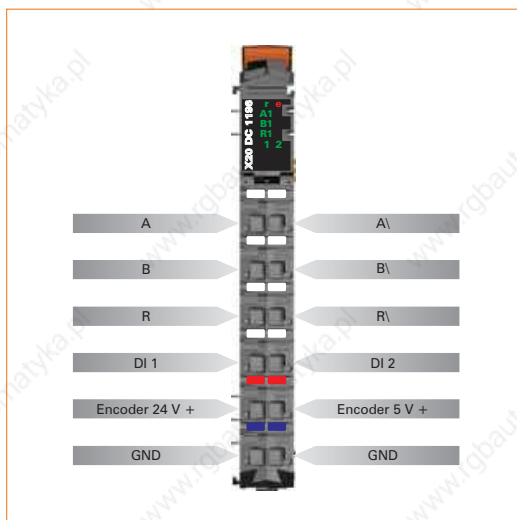

## Connection example

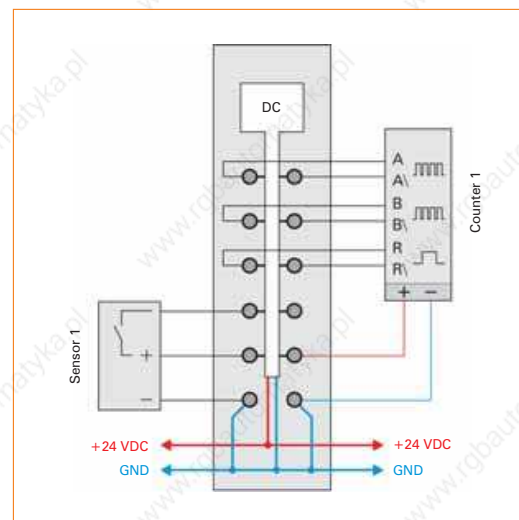

### Required accessories

X20TB12	X20 terminal block, 12-pin, 24 V coded	94
X20BM11	X20 bus module, 24 V coded, internal I/O supply is interconnected	88

## Counter module DC1198



- 1 5 V SSI absolute encoders
- 2 additional inputs
- 5 VDC, 24 VDC and GND for encoder supply

<b>Short description</b>	<b>X20DC1198</b>
I/O module	1 5 V SSI absolute encoders
<b>SSI absolute encoder</b>	<b>X20DC1198</b>
Encoder inputs	5 V, symmetrical
Counter size	32-bit
Maximum transfer rate	1 MBit/s
Encoder supply	
5 V	Module-internal, max. 300 mA
24 V	Module-internal, max. 300 mA
<b>Digital inputs</b>	<b>X20DC1198</b>
Amount	2
Rated voltage	24 VDC
Input filter	
Hardware	≤2 μs
Software	-
Connection type	3-line connections
Input circuit	Sink
<b>General information</b>	<b>X20DC1198</b>
Status indicators	I/O function per channel, operating state, module status
Diagnostics	
Module run/error	Yes, with status LED and software status
Electrical isolation	
Encoder - Bus	Yes
Channel - Bus	Yes
Channel - Encoder	No
Channel - Channel	No
Power consumption	
Bus	0.01 W
I/O internal	1.5 W
Certification	CE, C-UL-US, GOST-R
<b>Operational conditions</b>	<b>X20DC1198</b>
Operating temperature	
Horizontal installation	0°C to +55°C
Vertical installation	0°C to +50°C
Relative humidity	5 to 95%, non-condensing
Mounting orientation	Horizontal or vertical
Installation at altitudes above sea level	
0 - 2000 m	No derating
>2000 m	Reduction of ambient temperature by 0.5°C per 100 m
Protection type	IP20
<b>Storage and transport conditions</b>	<b>X20DC1198</b>
Temperature	-25°C to +70°C
Relative humidity	5 to 95%, non-condensing
<b>Mechanical characteristics</b>	<b>X20DC1198</b>
Spacing	12.5 <sup>+0.2</sup> mm
Comment	Order terminal block 1x X20TB12 separately Order bus module 1x X20BM11 separately

## Pin assignments

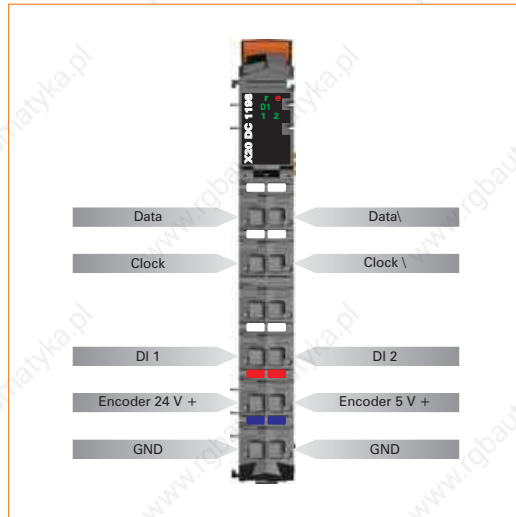

## Connection example

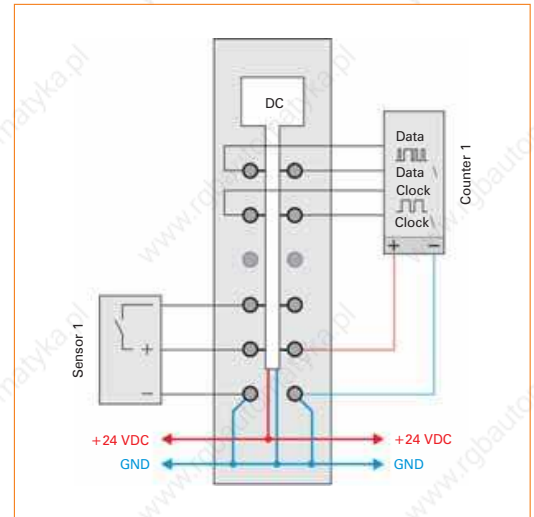

### Required accessories

X20TB12	X20 terminal block, 12-pin, 24 V coded	94
X20BM11	X20 bus module, 24 V coded, internal I/O supply is interconnected	88

## Counter module DC1396



- One 24 V ABR incremental encoder
- 1 additional input, e.g. for reference enable switch
- 24 VDC and GND for encoder supply

<b>Short description</b>	<b>X20DC1396</b>
I/O module	One 24 V ABR incremental encoder
<b>ABR incremental encoder</b>	<b>X20DC1396</b>
Encoder inputs	24 V, asymmetrical
Counter size	16/32-bit
Input frequency (max.)	100 kHz
Evaluation	4x
Encoder supply	Module-internal, max. 600 mA
<b>Reference enable switch</b>	<b>X20DC1396</b>
Amount	1
Rated voltage	24 VDC
Input filter	
Hardware	≤2 μs
Software	-
Connection type	3-line connections
Input circuit	Sink
<b>General information</b>	<b>X20DC1396</b>
Status indicators	I/O function per channel, operating state, module status
Diagnostics	
Module run/error	Yes, with status LED and software status
Electrical isolation	
Encoder - Bus	Yes
Reference enable switch - Bus	Yes
Reference enable switch - Encoder	No
Power consumption	
Bus	0.01 W
I/O internal	1.4 W
Certification	CE, C-UL-US, GOST-R
<b>Operational conditions</b>	<b>X20DC1396</b>
Operating temperature	
Horizontal installation	0°C to +55°C
Vertical installation	0°C to +50°C
Relative humidity	5 to 95%, non-condensing
Mounting orientation	Horizontal or vertical
Installation at altitudes above sea level	
0 - 2000 m	No derating
>2000 m	Reduction of ambient temperature by 0.5°C per 100 m
Protection type	IP20
<b>Storage and transport conditions</b>	<b>X20DC1396</b>
Temperature	-25°C to +70°C
Relative humidity	5 to 95%, non-condensing
<b>Mechanical characteristics</b>	<b>X20DC1396</b>
Spacing	12.5 <sup>+0.2</sup> mm
Comment	Order terminal block 1x X20TB12 separately Order bus module 1x X20BM11 separately

### Pin assignments



### Connection example

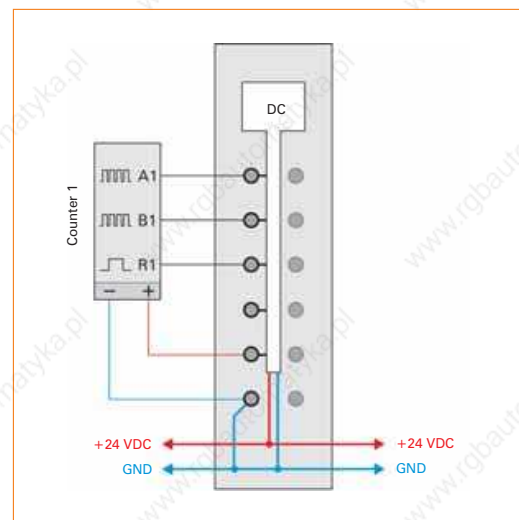

#### Required accessories

X20TB12	X20 terminal block, 12-pin, 24 V coded	94
X20BM11	X20 bus module, 24 V coded, internal I/O supply is interconnected	88

## Counter module DC1398



- 1 24 V SSI absolute encoders
- 1 additional input
- 24 VDC and GND for encoder supply

<b>Short description</b>	<b>X20DC1398</b>
I/O module	1 24 V SSI absolute encoders
<b>SSI absolute encoder</b>	<b>X20DC1398</b>
Encoder inputs	24 V, asymmetrical
Counter size	32-bit
Maximum transfer rate	125 kBit/s
Encoder supply	Module-internal, max. 600 mA
<b>Digital inputs</b>	<b>X20DC1398</b>
Amount	1
Rated voltage	24 VDC
Input filter	
Hardware	≤2 μs
Software	-
Connection type	3-line connections
Input circuit	Sink
<b>General information</b>	<b>X20DC1398</b>
Status indicators	I/O function per channel, operating state, module status
Diagnostics	
Module run/error	Yes, with status LED and software status
Electrical isolation	
Encoder - Bus	Yes
Channel - Bus	Yes
Channel - Encoder	No
Power consumption	
Bus	0.01 W
I/O internal	1.3 W
Certification	CE, C-UL-US, GOST-R
<b>Operational conditions</b>	<b>X20DC1398</b>
Operating temperature	
Horizontal installation	0°C to +55°C
Vertical installation	0°C to +50°C
Relative humidity	5 to 95%, non-condensing
Mounting orientation	Horizontal or vertical
Installation at altitudes above sea level	
0 - 2000 m	No derating
>2000 m	Reduction of ambient temperature by 0.5°C per 100 m
Protection type	IP20
<b>Storage and transport conditions</b>	<b>X20DC1398</b>
Temperature	-25°C to +70°C
Relative humidity	5 to 95%, non-condensing
<b>Mechanical characteristics</b>	<b>X20DC1398</b>
Spacing	12.5 <sup>+0.2</sup> mm
Comment	Order terminal block 1x X20TB12 separately Order bus module 1x X20BM11 separately

## Pin assignments

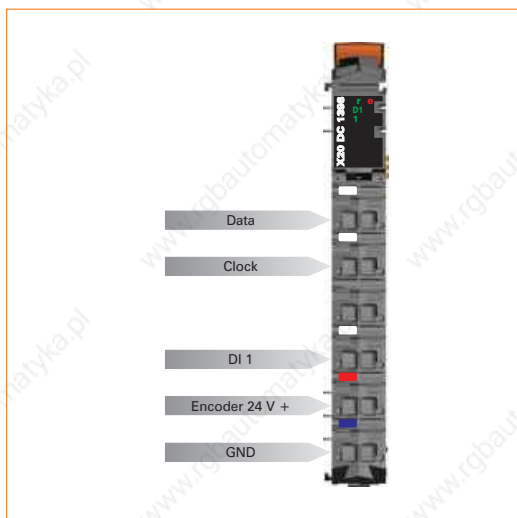

## Connection example

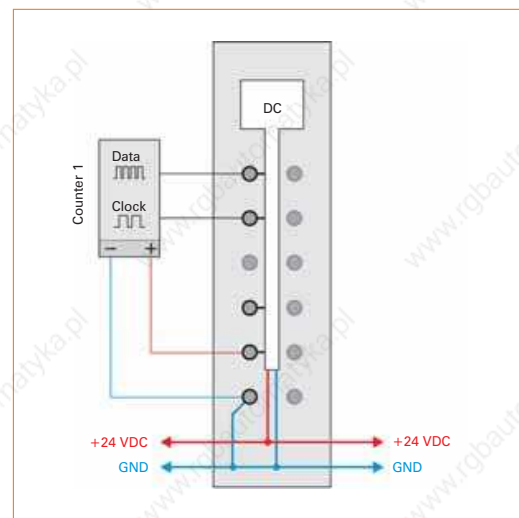

### Required accessories

X20TB12	X20 terminal block, 12-pin, 24 V coded	94
X20BM11	X20 bus module, 24 V coded, internal I/O supply is interconnected	88

## Counter module DC2190



- Ultrasonic transducer module
- Path measurement (resolution at least 10  $\mu\text{m}$ )
- Speed measurement (resolution at least 100  $\mu\text{m/s}$ )
- 1, 2, 3 and 4 magnetic bar measurements possible
- DPI/IP protocol supported

<b>Short description</b>	<b>X20DC2190</b>
I/O module	Ultrasonic transducer module, 2 transducer rods, 4 path evaluation, speed measurement
<b>Channels for path and speed measurements</b>	<b>X20DC2190</b>
Number of channels	2
Supported encoder types	Start/Stop interface EP start/stop - interface DPI/IP interface
Encoder supply	24 VDC internal supply, with configurable overvoltage/undervoltage monitoring ( $\pm 10\%$ , $\pm 15\%$ , $\pm 20\%$ , $\pm 25\%$ )
Input and output level	RS422 differential level
Multi-magnet measurement	Yes, in combinations per rod, max. 4 magnets total
Outputs	1.6 $\mu\text{s}$ durational initialization pulse
Inputs	
Path measurement	Resolution = 0.01 mm, measurement range = $\pm 5.2$ m
Speed measurement	Resolution = 0.1 mm/s, measurement range = $\pm 3.2$ m/s
Accuracy	$\pm 50$ ppm $\pm 5$ ppm/year
<b>General information</b>	<b>X20DC2190</b>
Status indicators	I/O function per channel, operating state, module status
Diagnosics	
Module run/error	Yes, with status LED and software status
Electrical isolation	
Channel - Bus	Yes
Channel - Channel	No
Power consumption	
Bus	0.01 W
I/O internal	1.1 W
Certification	CE, C-UL-US, GOST-R
<b>Operational conditions</b>	<b>X20DC2190</b>
Operating temperature	
Horizontal installation	0°C to +55°C
Vertical installation	0°C to +50°C
Relative humidity	5 to 95%, non-condensing
Mounting orientation	Horizontal or vertical
Installation at altitudes above sea level	
0 - 2000 m	No derating
>2000 m	Reduction of ambient temperature by 0.5°C per 100 m
Protection type	IP20
<b>Storage and transport conditions</b>	<b>X20DC2190</b>
Temperature	-25°C to +70°C
Relative humidity	5 to 95%, non-condensing
<b>Mechanical characteristics</b>	<b>X20DC2190</b>
Spacing	12.5 $^{+0.2}$ mm
Comment	Order terminal block 1x X20TB12 separately Order bus module 1x X20BM11 separately

## Pin assignments

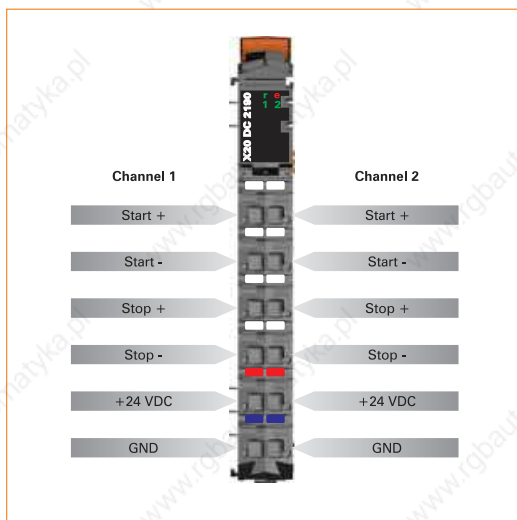

## Connection example

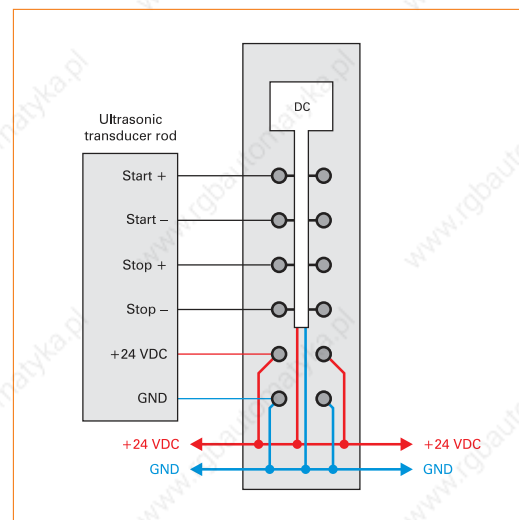

### Required accessories

X20TB12	X20 terminal block, 12-pin, 24 V coded	94
X20BM11	X20 bus module, 24 V coded, internal I/O supply is interconnected	88

## Counter module DC2396



- Two 24 V ABR incremental encoders
- 2 additional inputs, e.g. for Reference enable switch
- 24 VDC and GND for encoder supply

<b>Short description</b>	<b>X20DC2396</b>
I/O module	Two 24 V ABR incremental encoders
<b>ABR incremental encoder</b>	<b>X20DC2396</b>
Encoder inputs	24 V, asymmetrical
Counter size	16/32-bit
Input frequency (max.)	100 kHz
Evaluation	4x
Encoder supply	Module-internal, max. 600 mA
<b>Reference enable switch</b>	<b>X20DC2396</b>
Amount	2
Rated voltage	24 VDC
Input filter	
Hardware	≤2 μs
Software	-
Connection type	3-line connections
Input circuit	Sink
<b>General information</b>	<b>X20DC2396</b>
Status indicators	I/O function per channel, operating state, module status
Diagnostics	
Module run/error	Yes, with status LED and software status
Electrical isolation	
Encoder - Bus	Yes
Reference enable switch - Bus	Yes
Reference enable switch - Encoder	No
Encoder - Encoder	No
Reference switch - Reference switch	No
Power consumption	
Bus	0.01 W
I/O internal	1.5 W
Certification	CE, C-UL-US, GOST-R
<b>Operational conditions</b>	<b>X20DC2396</b>
Operating temperature	
Horizontal installation	0°C to +55°C
Vertical installation	0°C to +50°C
Relative humidity	5 to 95%, non-condensing
Mounting orientation	Horizontal or vertical
Installation at altitudes above sea level	
0 - 2000 m	No derating
>2000 m	Reduction of ambient temperature by 0.5°C per 100 m
Protection type	IP20
<b>Storage and transport conditions</b>	<b>X20DC2396</b>
Temperature	-25°C to +70°C
Relative humidity	5 to 95%, non-condensing
<b>Mechanical characteristics</b>	<b>X20DC2396</b>
Spacing	12.5 <sup>+0.2</sup> mm
Comment	Order terminal block 1x X20TB12 separately Order bus module 1x X20BM11 separately

## Pin assignments

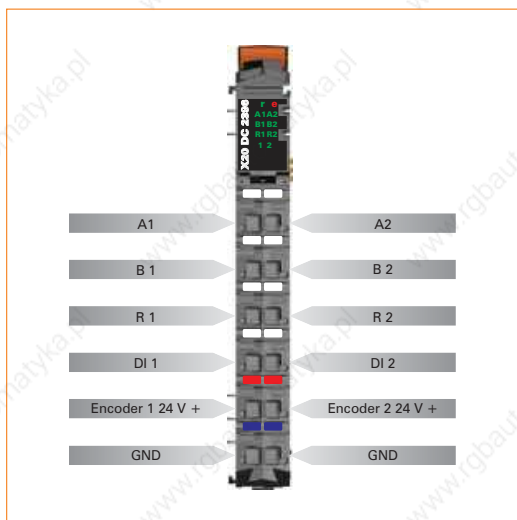

## Connection example

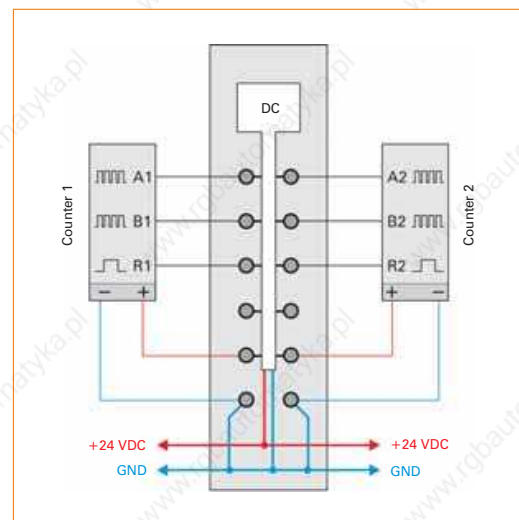

### Required accessories

X20TB12	X20 terminal block, 12-pin, 24 V coded	94
X20BM11	X20 bus module, 24 V coded, internal I/O supply is interconnected	88

## Counter module DC2398



- 2 24 V SSI absolute encoders
- 2 additional inputs
- 24 VDC and GND for encoder supply

<b>Short description</b>	<b>X20DC2398</b>
I/O module	2 24 V SSI absolute encoders
<b>SSI absolute encoder</b>	<b>X20DC2398</b>
Encoder inputs	24 V, asymmetrical
Counter size	32-bit
Maximum transfer rate	125 kBit/s
Encoder supply	Module-internal, max. 600 mA
<b>Digital inputs</b>	<b>X20DC2398</b>
Amount	2
Rated voltage	24 VDC
Input filter	
Hardware	≤2 μs
Software	-
Connection type	3-line connections
Input circuit	Sink
<b>General information</b>	<b>X20DC2398</b>
Status indicators	I/O function per channel, operating state, module status
Diagnosics	
Module run/error	Yes, with status LED and software status
Electrical isolation	
Encoder - Bus	Yes
Channel - Bus	Yes
Channel - Encoder	No
Encoder - Encoder	No
Channel - Channel	No
Power consumption	
Bus	0.01 W
I/O internal	1.4 W
Certification	CE, C-UL-US, GOST-R
<b>Operational conditions</b>	<b>X20DC2398</b>
Operating temperature	
Horizontal installation	0°C to +55°C
Vertical installation	0°C to +50°C
Relative humidity	5 to 95%, non-condensing
Mounting orientation	Horizontal or vertical
Installation at altitudes above sea level	
0 - 2000 m	No derating
>2000 m	Reduction of ambient temperature by 0.5°C per 100 m
Protection type	IP20
<b>Storage and transport conditions</b>	<b>X20DC2398</b>
Temperature	-25°C to +70°C
Relative humidity	5 to 95%, non-condensing
<b>Mechanical characteristics</b>	<b>X20DC2398</b>
Spacing	12.5 <sup>+0.2</sup> mm
Comment	Order terminal block 1x X20TB12 separately Order bus module 1x X20BM11 separately

## Pin assignments

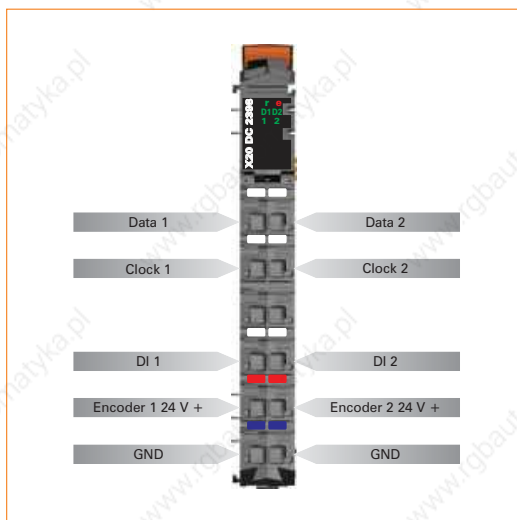

## Connection example

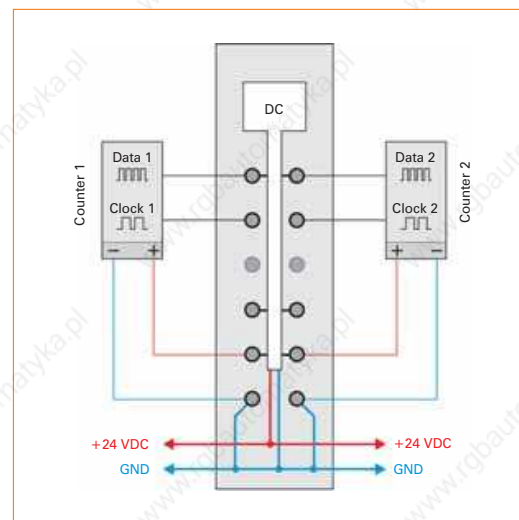

### Required accessories

X20TB12	X20 terminal block, 12-pin, 24 V coded	94
X20BM11	X20 bus module, 24 V coded, internal I/O supply is interconnected	88

## Counter module DC2395



The DC2395 module is a multifunctional counter module. It can be connected to an SSI encoder, an ABR encoder, two AB encoders, or four event counters.

Two outputs are available for pulse width modulation. The functions can also be mixed.

- 24 VDC encoder inputs
- SSI, ABR, AB or event counters for inputs
- Pulse width modulation for outputs
- 24 VDC and GND for encoder supply

<b>Short description</b>	<b>X20DC2395</b>
I/O module	1 SSI absolute encoders, 24 V, 1 ABR incremental encoders, 24 V, 2 AB incremental encoders, 24 V, 4x event counters or 2x pulse width modulation, time measurement, relative time stamp
<b>SSI absolute encoder</b>	<b>X20DC2395</b>
Amount	1
Encoder inputs	24 V, asymmetrical
Counter size	32-bit
Maximum transfer rate	125 kBit/s
Encoder supply	Module-internal, max. 600 mA
<b>Incremental encoder</b>	<b>X20DC2395</b>
Amount	2
Encoder inputs	24 V, asymmetrical
Counter size	16/32-bit
Input frequency (max.)	100 kHz
Evaluation	4x
Encoder supply	Module-internal, max. 600 mA
<b>Event counter</b>	<b>X20DC2395</b>
Amount	4
Rated voltage	24 VDC
Counter size	16-bit
Input frequency (max.)	100 kHz
Evaluation	Each edge, cyclic counter
Signal form	Square wave pulse
<b>Time measurement</b>	<b>X20DC2395</b>
Possible measurements	Gate time, period duration, edge offset for various channels
Measurements per module	Up to 9
Measurements per channel	Up to 2
Counter size	16-bit
Internal counter frequency	8 MHz, 4 MHz, 2 MHz, 1 MHz, 500 kHz, 250 kHz, 125 kHz, 62.5 kHz
Signal form	Square wave pulse
Measurement type	Continuous or triggered
<b>Digital outputs</b>	<b>X20DC2395</b>
Amount	2
Rated voltage	24 VDC
Rated output current	0.1 A
Total current	0.2 A
Output circuit	Sink or source
Output protection	Thermal cutoff for overcurrent and short circuit, integrated protection for switching inductances
Pulse width modulation <sup>1)</sup>	
Period duration	41.6 μs to 1.36 s
Factor for period duration	n/48000 s, n = 2 to 65535
Pulse length	0 to 100%
Resolution for pulse length	0.1%
Actuator supply	Module-internal, max. 600 mA

1) Dead time when switching between push and pull: Max 1.5 μs

<b>General information</b>	<b>X20DC2395</b>
Status indicators	I/O function per channel, operating state, module status
<b>Diagnostics</b>	
Module run/error	Yes, with status LED and software status
Outputs	Yes, with status LED and software status (output status)
<b>Electrical isolation</b>	
Encoder - Bus	Yes
Output - Bus	Yes
Output - Encoder	No
Encoder - Encoder	No
Output - Output	No
<b>Power consumption</b>	
Bus	0.01 W
I/O internal	1.4 W
Certification	CE, C-UL-US, GOST-R
<b>Operational conditions</b>	<b>X20DC2395</b>
<b>Operating temperature</b>	
Horizontal installation	0°C to +55°C
Vertical installation	0°C to +50°C
Relative humidity	5 to 95%, non-condensing
Mounting orientation	Horizontal or vertical
<b>Installation at altitudes above sea level</b>	
0 - 2000 m	No derating
>2000 m	Reduction of ambient temperature by 0.5°C per 100 m
Protection type	IP20
<b>Storage and transport conditions</b>	<b>X20DC2395</b>
Temperature	-25°C to +70°C
Relative humidity	5 to 95%, non-condensing
<b>Mechanical characteristics</b>	<b>X20DC2395</b>
Spacing	12.5 <sup>+0.2</sup> mm
Comment	Order terminal block 1x X20TB12 separately Order bus module 1x X20BM11 separately

**Note:** This module is a multi-function module. Some bus controllers only support the default function model described below. This is indicated in the documentation for the individual bus controllers.

Default function model:

- 2x event counter (24 V)
- 2x PWM output (24 V)

# Counter module DC2395

## Pin assignments

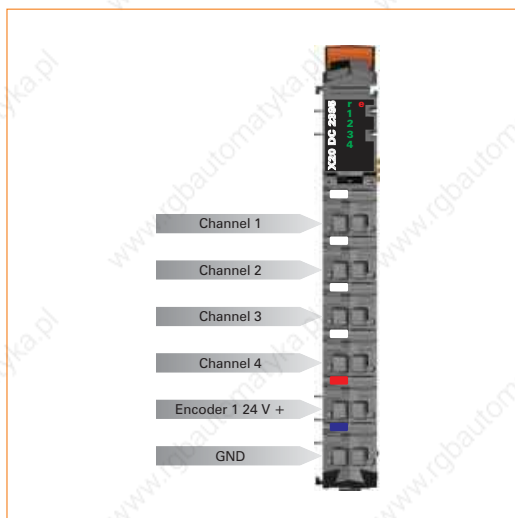

## Connection example

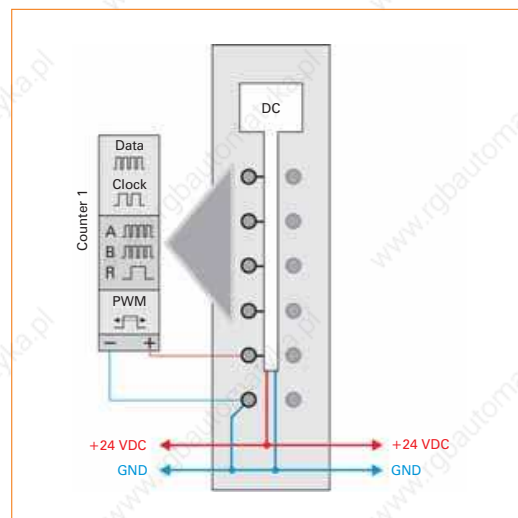

### Required accessories

X20TB12	X20 terminal block, 12-pin, 24 V coded	94
X20BM11	X20 bus module, 24 V coded, internal I/O supply is interconnected	88



## Counter module DC4395



The DC4395 module is a multifunctional counter module. It can be connected to two SSI encoders, two ABR encoders, four AB encoders, or eight event counters.

Four outputs are available for pulse width modulation. The functions can also be mixed.

- 24 VDC encoder inputs
- SSI, ABR, AB or event counters for inputs
- Pulse width modulation for outputs
- 24 VDC and GND for encoder supply

<b>Short description</b>	<b>X20DC4395</b>
I/O module	2 SSI absolute encoders, 24 V, 2 ABR incremental encoders, 24 V, 4 AB incremental encoders, 24 V, 8x event counters or 4x pulse width modulation, time measurement, relative time stamp
<b>SSI absolute encoder</b>	<b>X20DC4395</b>
Amount	2
Encoder inputs	24 V, asymmetrical
Counter size	32-bit
Maximum transfer rate	125 kBit/s
Encoder supply	Module-internal, max. 600 mA
<b>Incremental encoder</b>	<b>X20DC4395</b>
Amount	4
Encoder inputs	24 V, asymmetrical
Counter size	16/32-bit
Input frequency (max.)	100 kHz
Evaluation	4x
Encoder supply	Module-internal, max. 600 mA
<b>Event counter</b>	<b>X20DC4395</b>
Amount	8
Rated voltage	24 VDC
Counter size	16-bit
Input frequency (max.)	100 kHz
Evaluation	Each edge, cyclic counter
Signal form	Square wave pulse
<b>Time measurement</b>	<b>X20DC4395</b>
Possible measurements	Gate time, period duration, edge offset for various channels
Measurements per module	Up to 9
Measurements per channel	Up to 2
Counter size	16-bit
Internal counter frequency	8 MHz, 4 MHz, 2 MHz, 1 MHz, 500 kHz, 250 kHz, 125 kHz, 62.5 kHz
Signal form	Square wave pulse
Measurement type	Continuous or triggered
<b>Digital outputs</b>	<b>X20DC4395</b>
Amount	4
Rated voltage	24 VDC
Rated output current	0.1 A
Total current	0.4 A
Output circuit	Sink or source
Output protection	Thermal cutoff for overcurrent and short circuit, integrated protection for switching inductances
Pulse width modulation <sup>1)</sup>	
Period duration	41.6 μs to 1.36 s
Factor for period duration	n/48000 s, n = 2 to 65535
Pulse length	0 to 100%
Resolution for pulse length	0.1%
Actuator supply	Module-internal, max. 600 mA

1) Dead time when switching between push and pull: Max 1.5 μs

<b>General information</b>	<b>X20DC4395</b>
Status indicators	I/O function per channel, operating state, module status
<b>Diagnostics</b>	
Module run/error	Yes, with status LED and software status
Outputs	Yes, with status LED and software status (output status)
<b>Electrical isolation</b>	
Encoder - Bus	Yes
Output - Bus	Yes
Output - Encoder	No
Encoder - Encoder	No
Output - Output	No
<b>Power consumption</b>	
Bus	0.01 W
I/O internal	1.5 W
Certification	CE, C-UL-US, GOST-R
<b>Operational conditions</b>	<b>X20DC4395</b>
<b>Operating temperature</b>	
Horizontal installation	0°C to +55°C
Vertical installation	0°C to +50°C
Relative humidity	5 to 95%, non-condensing
Mounting orientation	Horizontal or vertical
<b>Installation at altitudes above sea level</b>	
0 - 2000 m	No derating
>2000 m	Reduction of ambient temperature by 0.5°C per 100 m
Protection type	IP20
<b>Storage and transport conditions</b>	<b>X20DC4395</b>
Temperature	-25°C to +70°C
Relative humidity	5 to 95%, non-condensing
<b>Mechanical characteristics</b>	<b>X20DC4395</b>
Spacing	12.5 <sup>+0.2</sup> mm
Comment	Order terminal block 1x X20TB12 separately Order bus module 1x X20BM11 separately

**Note:** This module is a multi-function module. Some bus controllers only support the default function model described below. This is indicated in the documentation for the individual bus controllers.

Default function model:

- 1x ABR incremental encoder (24 V)
- 1x SSI absolute encoder (24 V)
- 1x event counter (24 V)
- 2x PWM output (24 V)

# Counter module DC4395

## Pin assignments

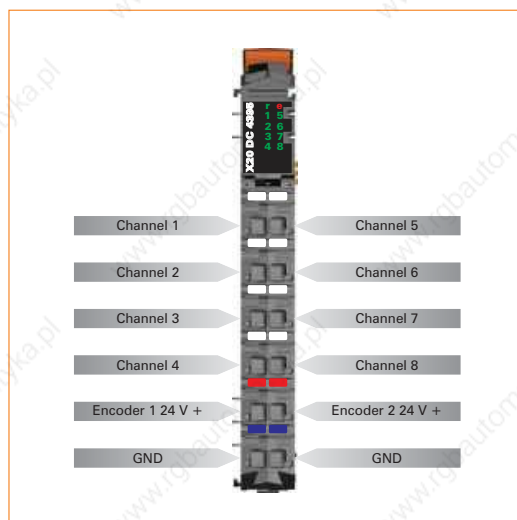

## Connection example

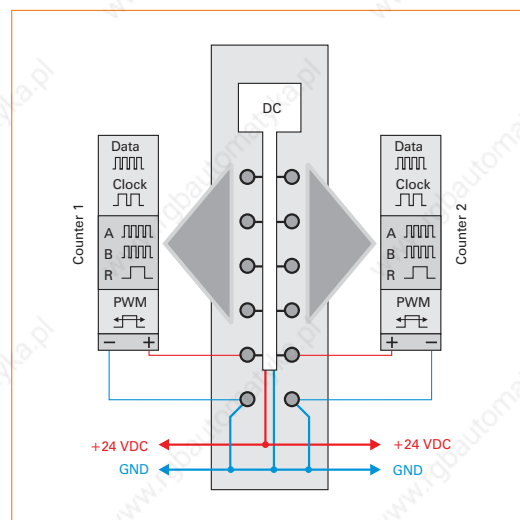

### Required accessories

X20TB12	X20 terminal block, 12-pin, 24 V coded	94
X20BM11	X20 bus module, 24 V coded, internal I/O supply is interconnected	88



## Counter module DS1119



The DS1119 is a multifunctional digital signal processor module. Its flexibility allows it to be implemented for a wide range of tasks involving the creation or processing of digital signals. For example, two main uses include encoder emulation and controlling stepper output stages with pulse and direction signals. When used for encoder emulation, frequency inverters or servo axes with the speed follow function can follow a real or virtual master axis.

A further important feature is the time stamp function, which is integrated in the module. It can be used, for example, to create ramp curves for the counter in the encoder emulation virtually independent of bus cycle times. Only the target counter value and the time that it should be reached must be entered. The module generates the appropriate counter values, precisely in microsecond resolution and independently of the bus clock.

- 3 digital 5 V channels, can be configured as input or output
- 2 digital 24 V input channels
- Up to 2 event counters
- 1 universal counter pair, can be configured as A/B counter or as up/down counter
- Linear movement generator (A/B; direction/frequency) with one reference pulse
- SSI absolute encoder

<b>Short description</b>	<b>X20DS1119</b>
I/O module	3 digital 5 V (symmetric) channels that can be configured as inputs or outputs, 2 digital 24 V (asymmetric) input channels, max. 2 event counters, 1 universal counter pair that can be configured as A/B counter or up/down counter, linear movement generator (A/B; dir./freq.) with one reference pulse, SSI absolute encoder
<b>Digital inputs 5 VDC</b>	<b>X20DS1119</b>
Amount	Up to 3, configuration as input or output takes place using software
Rated voltage	5 VDC differential signal, EIA RS-485 standard
Input frequency	250 kHz
Additional functions for inputs	AB counter, SSI absolute encoder, event counter, up/down counter
<b>Digital inputs 24 VDC</b>	<b>X20DS1119</b>
Amount	2
Rated voltage	24 VDC
Input frequency	100 kHz
Input circuit	Sink
Additional functions for inputs	Reference enable input for A/B, event counting, latch function
<b>Digital outputs 5 VDC</b>	<b>X20DS1119</b>
Amount	Up to 3, configuration as input or output takes place using software
Type	5 VDC differential signal, EIA RS-485 standard
Output circuit	Sink and/or source
Output protection	Short circuit protection
<b>Universal counter pair</b>	<b>X20DS1119</b>
Amount	1
Operating mode	2x event counter, up/down counter, A/B counter
Encoder inputs	5 V, symmetrical
Counter size	16/32-bit
Input frequency (max.)	250 kHz
Evaluation	
AB counter	4x
Up/down counter, event counter	2x
Encoder supply	
5 VDC	Module-internal, max. 300 mA
24 VDC	Module-internal, max. 300 mA
<b>SSI absolute encoder</b>	<b>X20DS1119</b>
Amount	1
Encoder inputs	5 V, symmetrical
Counter size	16/32-bit
Maximum transfer rate	1 MBit/s
Encoder supply	
5 VDC	Module-internal, max. 300 mA
24 VDC	Module-internal, max. 300 mA
<b>Linear movement generator</b>	<b>X20DS1119</b>
Amount	1
Encoder outputs	5 V, symmetric (A/B; direction/frequency)
Counter size	16/32-bit

<b>General information</b>	<b>X20DS1119</b>
Status indicators	I/O function per channel, operating state, module status
<b>Diagnostics</b>	
Module run/error	Yes, with status LED and software status
Inputs/outputs	Yes, with status LED
<b>Electrical isolation</b>	
Encoder - Bus	Yes
Output - Bus	Yes
Output - Encoder	No
Encoder - Encoder	No
Output - Output	No
<b>Power consumption</b>	
Bus	Typ. 0.01 W
I/O internal	Typ. 1.5 W
Certification	CE, C-UL-US (in development), GOST-R
<b>Operational conditions</b>	<b>X20DS1119</b>
<b>Operating temperature</b>	
Horizontal installation	0°C to +55°C
Vertical installation	0°C to +50°C
Relative humidity	5 to 95%, non-condensing
Mounting orientation	Horizontal or vertical
<b>Installation at altitudes above sea level</b>	
0 - 2000 m	No derating
>2000 m	Reduction of ambient temperature by 0.5°C per 100 m
Protection type	IP20
<b>Storage and transport conditions</b>	<b>X20DS1119</b>
Temperature	-25°C to +70°C
Relative humidity	5 to 95%, non-condensing
<b>Mechanical characteristics</b>	<b>X20DS1119</b>
Spacing	12.5 <sup>+0.2</sup> mm
Comment	Order terminal block 1x X20TB12 separately Order bus module 1x X20BM11 separately

# Counter module DS1119

## Pin assignments

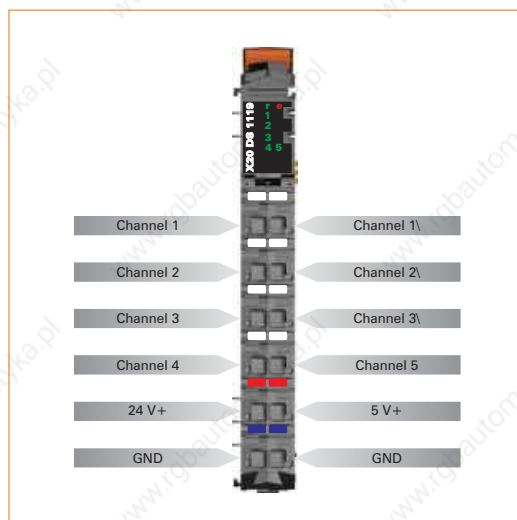

## Connection example

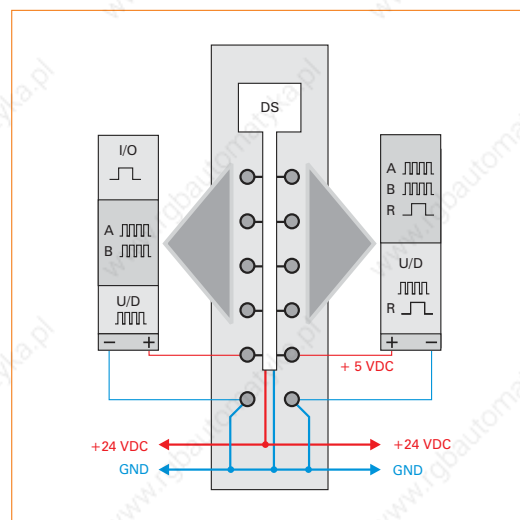

### Required accessories

X20TB12	X20 terminal block, 12-pin, 24 V coded	94
X20BM11	X20 bus module, 24 V coded, internal I/O supply is interconnected	88



## Counter module DS1319



The DS1319 is a multifunctional digital signal processor module. Its flexibility allows it to be implemented for a wide range of tasks involving the creation or processing of digital signals. For example, two main uses include encoder emulation and controlling stepper output stages with pulse and direction signals. When used for encoder emulation, frequency inverters or servo axes with the speed follow function can follow a real or virtual master axis.

A further important feature is the time stamp function, which is integrated in the module. It can be used, for example, to create ramp curves for the counter in the encoder emulation virtually independent of bus cycle times. Only the target counter value and the time that it should be reached must be entered. The module generates the appropriate counter values, precisely in microsecond resolution and independently of the bus clock.

- 4 digital input channels
- 4 digital channels, can be configured as inputs or outputs
- Up to 2 event counters
- 1 universal counter pair, can be configured as A/B counter or as up/down counter
- Linear movement generator (A/B; direction/frequency) with up to two reference pulses
- SSI absolute encoder

<b>Short description</b>	<b>X20DS1319</b>
I/O module	4 digital input channels, 4 digital channels that can be configured as input or output, max. 2 event counters, 1 universal counter pair that can be configured as A/B encoder or up/down counter, linear movement generator (A/B; direction/frequency) with up to two reference pulses, SSI absolute encoder
<b>Digital inputs</b>	<b>X20DS1319</b>
Amount	8
Rated voltage	24 VDC
Input frequency	100 kHz
Input circuit	Sink
Additional functions for inputs	AB counter, SSI abs. encoder, event counter, up/down counter, ref. enable for A/B counter, latch function
<b>Digital outputs</b>	<b>X20DS1319</b>
Amount	4
Rated voltage	24 VDC
Rated output current	0.1 A
Total current	0.4 A
Output circuit	Sink and/or source
Output protection	Thermal cutoff for overcurrent and short circuit, integrated protection for switching inductances
<b>Universal counter pair</b>	<b>X20DS1319</b>
Amount	1
Operating mode	2x event counter, up/down counter, A/B counter
Encoder inputs	24 V, asymmetrical
Counter size	16/32-bit
Input frequency (max.)	100 kHz
Evaluation	
AB counter	4x
Up/down counter, event counter	2x
Signal form	Square wave pulse
Encoder supply	Module-internal, max. 600 mA
<b>SSI absolute encoder</b>	<b>X20DS1319</b>
Amount	1
Rated voltage	24 V, asymmetrical
Counter size	16/32-bit
Maximum transfer rate	125 kBit/s
Encoder supply	Module-internal, max. 600 mA
<b>Linear movement generator</b>	<b>X20DS1319</b>
Amount	1
Encoder outputs	24 V, asymmetric (A/B; direction/frequency)
Counter size	16/32-bit
<b>General information</b>	<b>X20DS1319</b>
Status indicators	I/O function per channel, operating state, module status
Diagnosics	
Module run/error	Yes, with status LED and software status
Inputs/outputs	Yes, with status LED
Electrical isolation	
Encoder - Bus	Yes
Output - Bus	Yes
Output - Encoder	No
Encoder - Encoder	No
Output - Output	No
Power consumption	
Bus	Typ. 0.01 W
I/O internal	Typ. 1.5 W
Certification	CE, C-UL-US, GOST-R

Operational conditions		X20DS1319
Operating temperature		
Horizontal installation		0°C to +55°C
Vertical installation		0°C to +50°C
Relative humidity		
		5 to 95%, non-condensing
Mounting orientation		
		Horizontal or vertical
Installation at altitudes above sea level		
0 - 2000 m		No derating
>2000 m		Reduction of ambient temperature by 0.5°C per 100 m
Protection type		
		IP20
Storage and transport conditions		X20DS1319
Temperature		
		-25°C to +70°C
Relative humidity		
		5 to 95%, non-condensing
Mechanical characteristics		X20DS1319
Spacing		
		12.5 <sup>+0.2</sup> mm
Comment		
		Order terminal block 1x X20TB12 separately
		Order bus module 1x X20BM11 separately

### Pin assignments

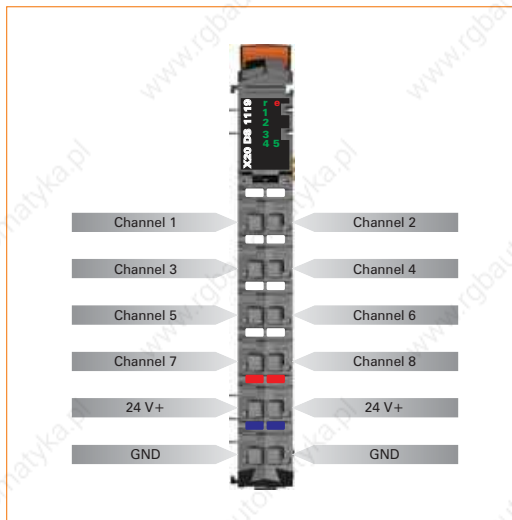

### Connection example

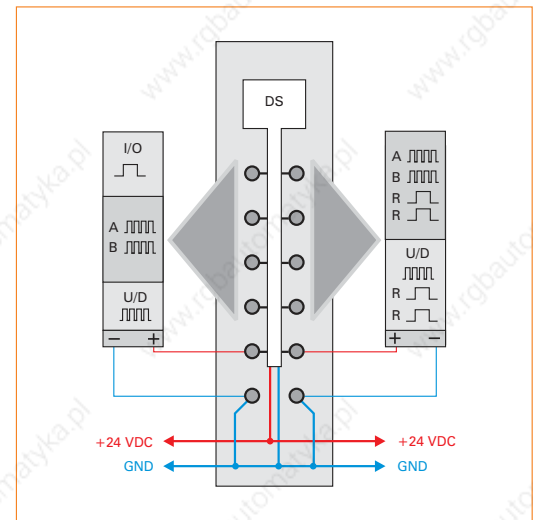

Required accessories		
X20TB12	X20 terminal block, 12-pin, 24 V coded	84
X20BM11	X20 bus module, 24 V coded, internal I/O supply is interconnected	88

# Dummy module ZF0000



- Place holder for later system expansion
- Used as a terminal holder
- Module with no electrical function

<b>Short description</b>	<b>X20ZF0000</b>
Accessories	Non-functional dummy module
<b>Operational conditions</b>	<b>X20ZF0000</b>
Operating temperature	
Horizontal installation	0°C to +55°C
Vertical installation	0°C to +50°C
Relative humidity	5 to 95%, non-condensing
Mounting orientation	Horizontal or vertical
Installation at altitudes above sea level	
0 - 2000 m	No derating
>2000 m	Reduction of ambient temperature by 0.5°C per 100 m
Protection type	IP20
<b>Storage and transport conditions</b>	<b>X20ZF0000</b>
Temperature	-25°C to +70°C
Relative humidity	5 to 95%, non-condensing
<b>Mechanical characteristics</b>	<b>X20ZF0000</b>
Spacing	12.5 <sup>+0.2</sup> mm
Comment	Order terminal block 1x X20TB06 or X20TB12 separately Order bus module 1x X20BM11 or supply bus module 1x X20BM01 separately

## Pin assignments



## Connection example

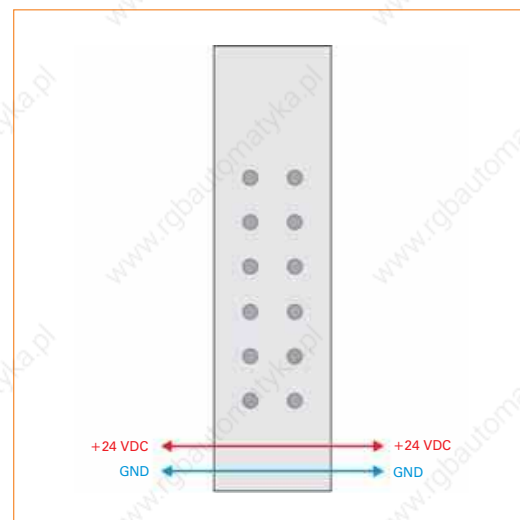

Required accessories		
X20TB06	X20 terminal block, 6-pin, 24 V coded	94
X20TB12	X20 terminal block, 12-pin, 24 V coded	94
X20BM01	X20 supply bus module, internal I/O supply is isolated to the left	86
X20BM11	X20 bus module, 24 V coded, internal I/O supply is interconnected	88



## Hub base module HB8880



The X20 hub HB8880 is a device that can be used universally in standard Ethernet networks or POWERLINK networks. It is suitable for 100 MBit/s (Fast Ethernet) networks.

The Ethernet connections are made using RJ45 connectors. The expanded bus modules allow up to two hub expansion modules to be mounted next to the hub base module. Each expansion module is equipped with two RJ45 connections. Together with the main device, this means that up to six hub ports are available.

- 2/4/6x Fast Ethernet Hub
- Modular design
- Easily expandable



<b>Short description</b>	<b>X20HB8880</b>
Hub	Modular X20 hub with up to two slots for hub expansion modules
<b>Interface</b>	<b>X20HB8880</b>
Type	Ethernet
Signal	100 Base-TX
Port design	Shielded RJ45 ports
Transfer rate	100 MBit/s
	Auto-MDI/MDIX
Cable length	Max. 100 m between two stations (segment length)
<b>General information</b>	<b>X20HB8880</b>
Status indicators	Module status, bus function
Diagnostics	
Module status	Yes, with status LED
Bus function	Yes, with status LED
Electrical isolation	
Fieldbus supply	Yes
Power consumption	2.0 W
Certification	CE, C-UL-US (in development), GOST-R

<b>Operational conditions</b>	<b>X20HB8880</b>
Operating temperature	
Horizontal installation	0°C to +55°C
Vertical installation	0°C to +50°C
Relative humidity	5 to 95%, non-condensing
Mounting orientation	Horizontal or vertical
Installation at altitudes above sea level	
0 - 2000 m	No derating
>2000 m	Reduction of ambient temperature by 0.5°C per 100 m
Protection type	IP20
<b>Storage and transport conditions</b>	<b>X20HB8880</b>
Temperature	-25°C to +70°C
Relative humidity	5 to 95%, non-condensing
<b>Mechanical characteristics</b>	<b>X20HB8880</b>
Grid size <sup>1)</sup>	
X20BB80	37.5 <sup>+0.2</sup> mm
X20BB81	62.5 <sup>+0.2</sup> mm
X20BB82	87.5 <sup>+0.2</sup> mm
Comment	Order terminal block 1x X20TB12 separately Order supply module 1x X20PS8002 separately Order 1x X20BB8x bus base separately

1) The spacing is based on the width of the X20BB8x bus base. Up to two X20HB2880 hub expansion modules and one X20PS8002 supply module are also always required for the hub.

<b>Required accessories</b>		
X20TB12	X20 terminal block, 12-pin, 24 V coded	94
X20PS8002	X20 supply module for stand alone hub and compact link selector	384
X20BB80	X20 bus base, for X20 base module (BC, HB, etc.) and X20 supply module, X20 end plates (left and right) X20AC0SL1/X20AC0SR1 included	170
X20BB81	X20 bus base with 1 expansion slot, for X20 base module (BC, HB, etc.) and one X20 auxiliary module (IF, HB, etc.) and X20 supply module, X20 end plates (left and right), X20AC0SL1/X20AC0SR1 included	184
X20BB82	X20 bus base with 2 expansion slots, for X20 base module (BC, HB, etc.) and two X20 auxiliary modules (IF, HB, etc.) and X20 supply module, X20 end plates (left and right), X20AC0SL1/X20AC0SR1 included	185
<b>Optional accessories</b>		
X20HB2880	X20 hub expansion module, 2x hub connection, status indicator LEDs, 2x RJ45 connection	187

## Supply module PS8002



The PS8002 supply module is used to supply X20 stand-alone devices. These include e.g. the HB8884 X20 POWER-LINK compact link selector and the HB8880 X20 stand-alone hub.

- Supply for X20 stand alone devices
- No electrical isolation between the module supply and the device supply

<b>Short description</b>	<b>X20PS8002</b>
Power supply module	24 VDC supply module for X20 stand alone devices
<b>Input supply</b>	<b>X20PS8002</b>
Input voltage	24 VDC (-15% / +20%)
Input current	Max. 0.7 A
Reverse polarity protection	Yes
Fuse	Integrated, cannot be exchanged
<b>Output supply</b>	<b>X20PS8002</b>
Rated output power	
Horizontal installation	7.0 W at 45°C and 5.0 W at 55°C
Vertical installation	7.0 W at 40°C and 5.0 W at 50°C
<b>General information</b>	<b>X20PS8002</b>
Status indicators	Operating status, module status
<b>Diagnostics</b>	
Module run/error	Yes, with status LED
Overload	Yes, with status LED
<b>Electrical isolation</b>	
Module supply - device supply	No
Power consumption <sup>1)</sup>	1.34 W
Certification	CE, C-UL-US (in development), GOST-R
<small>1) The specified values are maximum values. The exact calculation is available for download as a data sheet with the other module documentation on the B&amp;R homepage.</small>	
<b>Operational conditions</b>	<b>X20PS8002</b>
Operating temperature	
Horizontal installation	0°C to +55°C
Vertical installation	0°C to +50°C
Relative humidity	5 to 95%, non-condensing
Mounting orientation	Horizontal or vertical
Installation at altitudes above sea level	
0 - 2000 m	No derating
>2000 m	Reduction of ambient temperature by 0.5°C per 100 m
Protection type	IP20
<b>Storage and transport conditions</b>	<b>X20PS8002</b>
Temperature	-25°C to +70°C
Relative humidity	5 to 95%, non-condensing
<b>Mechanical characteristics</b>	<b>X20PS8002</b>
Spacing	12.5 <sup>+0.2</sup> mm
Comment	Order terminal block 1x X20TB12 separately

### Pin assignments

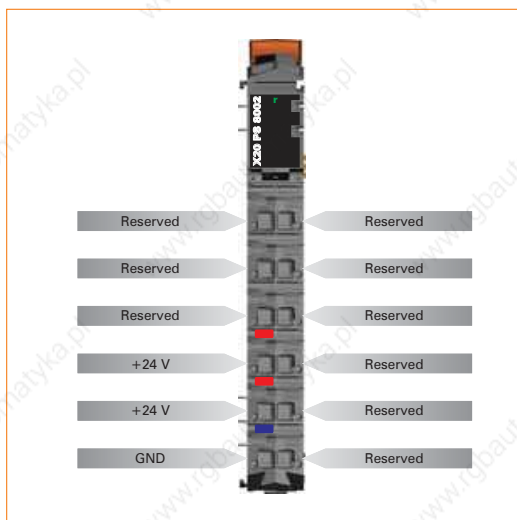

### Connection example

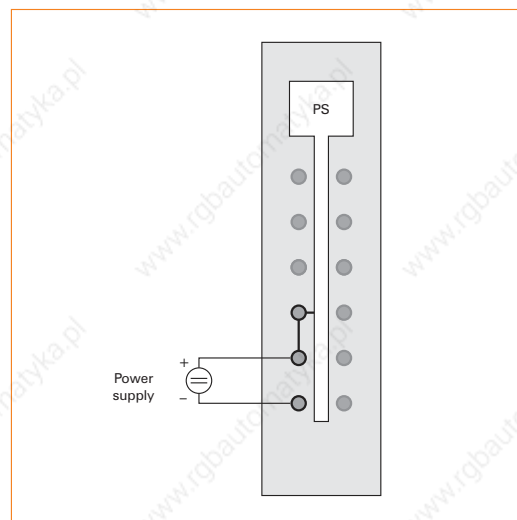

#### Required accessories

X20TB12 X20 terminal block, 12-pin, 24 V coded

94

## POWERLINK compact link selector HB8884



POWERLINK is a standard protocol for Fast Ethernet with true real-time properties. The Ethernet POWERLINK Standardization Group (EPSG, [www.ethernet-powerlink.org](http://www.ethernet-powerlink.org)) ensures that the standard remains open and is continually developed.

Using POWERLINK, systems with redundant cabling can be implemented. Unlike ring redundancy, cable looping, which can sometimes be problematic, is not required for cable redundancy. This allows the creation of all types of tree structures. When using a device with the link selector function, data is always transferred via the highest quality network lines. The link selector function is integrated in the HB8884 compact link selector. This makes it easy to connect any POWERLINK V2 device to a redundant POWERLINK V2 network (see sections "POWERLINK cable redundancy system", on page 57 and "X20 redundancy system", on page 57).

- Connecting POWERLINK V2 devices to the POWERLINK cable redundancy system
- Integrated compact link selector function



<b>Short description</b>	<b>X20HB8884</b>
POWERLINK compact link selector	Connecting POWERLINK V2 devices to a redundant POWERLINK V2 network
<b>Fieldbus</b>	<b>X20HB8884</b>
Type	POWERLINK V2 100 Base-T (ANSI/IEE 802.3)
Design	Internal 2x hub, 2x shielded RJ45 port
Cable length	Max. 100 m between two stations (segment length)
Transfer rate	100 MBit/s
<b>General information</b>	<b>X20HB8884</b>
Status indicators	Module status, bus function
Diagnostics	
Module status	Yes, with status LED
Bus function	Yes, with status LED
Electrical isolation	
Fieldbus supply	Yes
Power consumption of the bus	2.0 W
Certification	CE, C-UL-US (in development), GOST-R

ETHERNET   
**POWERLINK**

<b>Operational conditions</b>	<b>X20HB8884</b>
Operating temperature	
Horizontal installation	0°C to +55°C
Vertical installation	0°C to +50°C
Relative humidity	5 to 95%, non-condensing
Mounting orientation	Horizontal or vertical
Installation at altitudes above sea level	
0 - 2000 m	No derating
>2000 m	Reduction of ambient temperature by 0.5°C per 100 m
Protection type	IP20
<b>Storage and transport conditions</b>	<b>X20HB8884</b>
Temperature	-25°C to +70°C
Relative humidity	5 to 95%, non-condensing
<b>Mechanical characteristics</b>	<b>X20HB8884</b>
Grid size <sup>1)</sup>	
X20BB81	62.5 <sup>+0.2</sup> mm
X20BB82	87.5 <sup>+0.2</sup> mm
Comment	Order terminal block 1x X20TB12 separately Order supply module 1x X20PS8002 separately Order 1x X20HB2880 or 2x X20HB2885 hub expansion module separately Order 1x X20BB81 or X20BB82 bus base separately

1) The spacing is based on the width of the X20BB81 or X20BB82 bus base. One X20HB2880 hub expansion module or two X20HB2885 hub expansion modules and an X20PS8002 supply module are also always required for the compact link selector.

Required accessories		
X20TB12	X20 terminal block, 12-pin, 24 V coded	▮ 94
X20PS8002	X20 supply module for stand alone hub and compact link selector	▮ 384
X20HB2880	X20 hub expansion module, 2x hub connection, status indicator LEDs, 2x RJ45 connection	▮ 187
X20HB2885	X20 hub expansion module, integrated active 2x hub, status indicator LEDs, 2x RJ45 connection	▮ 188
X20BB81	X20 bus base with 1 expansion slot, for X20 base module (BC, HB, etc.) and one X20 auxiliary module (IF, HB, etc.) and X20 supply module, X20 end plates (left and right), X20AC0SL1/X20AC0SR1 included	▮ 184
X20BB82	X20 bus base with 2 expansion slots, for X20 base module (BC, HB, etc.) and two X20 auxiliary modules (IF, HB, etc.) and X20 supply module, X20 end plates (left and right), X20AC0SL1/X20AC0SR1 included	▮ 185

## Accessories



### Cover holder, terminal locking clip



Model number	Short description
X20AC0SC1	X20 terminal locking clip and cover holder for plain text cover.
X20AC0SC1.0100	X20 terminal locking clip and cover holder for plain text cover, 100 pcs. package

### Plain text cover



Model number	Short description
X20AC0SH1	X20 plain text cover
X20AC0SH1.0100	X20 plain text insert, 100 pcs. package
X20AC0LB1.0100	X20 legend strips for X20 plain text cover, paper, white, perforated, 96 strips on A4 sheets, 100 sheets per package

### Additional locking clip



Model number	Short description
X20AC0AX1	X20 additional locking clip
X20AC0AX1.0100	X20 additional locking clip, 100 pcs. package

## Locking plate



Model number	Short description
X20ACOSL1	X20 locking plate (left)
X20ACOSR1	X20 locking plate (right)
X20ACOSL1.0010	X20 locking plate (left), 10 pcs. package
X20ACOSR1.0010	X20 locking plate (right), 10 pcs. package

## Cable shielding plate



Model number	Short description
X20ACOSG1.0010	X20 cable shield grounding plate, 10 pcs. package
X20ACOSG1.0100	X20 cable shield grounding plate, 100 pcs. package

## Terminal labeling



Model number	Short description
X20ACOM01	Blank X20 label tabs, white, set for 16 modules
X20ACOM02	Blank X20 label tabs, red, set for 16 modules
X20ACOM03	Blank X20 label tabs, blue, set for 16 modules
X20ACOM04	Blank X20 label tabs, orange, set for 16 modules
X20ACOM11	Printed X20 label tabs, white, set for 16 modules. Text: Module (module 1 - 16), Terminal (1 - 192)
X20ACOM12	Printed X20 label tabs, red, set for 16 modules. Text: +24V
X20ACOM13	Printed X20 label tabs, blue, set for 16 modules. Text: GND
X20ACOM14	Printed X20 label tabs, orange, set for 16 modules. Text: Module (module 1 - 16), Terminal (1 - 192)
X20ACOM01.0010	Blank X20 label tabs, white, set for 16 modules, 10 pcs. package
X20ACOM02.0010	Blank X20 label tabs, red, set for 16 modules, 10 pcs. package
X20ACOM03.0010	Blank X20 label tabs, blue, set for 16 modules, 10 pcs. package
X20ACOM04.0010	Blank X20 label tabs, orange, set for 16 modules, 10 pcs. package
X20ACOM11.0010	Printed X20 label tabs, white, set for 16 modules, 10 pcs. / package. Text: Module (module 1 - 16), Terminal (1 - 192)
X20ACOM12.0010	Printed X20 label tabs, red, set for 16 modules, 10 pcs. / package. Text: +24V
X20ACOM13.0010	Printed X20 label tabs, blue, set for 16 modules, 10 pcs. / package. Text: GND
X20ACOM14.0010	Printed X20 label tabs, orange, set for 16 modules, 10 pcs. / package. Text: Module (module 1 - 16), Terminal (1 - 192)
X20ACOM21	Large blank X20 label tabs, white, set for 48 modules
X20ACOM21.0010	Large blank X20 label tabs, white, set for 48 modules, 10 pcs. package

# Accessories

## Labeling tool



Model number	Short description
X20AC0MT1	X20 labeling tool for the X20 label tabs

## X2X Link cable



Model number	Short description
X67CA0X99.1000	Cable for custom prefabrication, 100.0 m

**Ethernet POWERLINK cable  
RJ45 to RJ45**



Length	Connection cable Model number	Short description
0.2 m	X20CA0E61.0002	POWERLINK connection cable RJ45 to RJ45, 0.2 m
1.0 m	X20CA0E61.0010	POWERLINK connection cable RJ45 to RJ45, 1.0 m
2.0 m	X20CA0E61.0020	POWERLINK connection cable RJ45 to RJ45, 2.0 m
5.0 m	X20CA0E61.0050	POWERLINK connection cable RJ45 to RJ45, 5.0 m
10.0 m	X20CA0E61.0100	POWERLINK connection cable RJ45 to RJ45, 10.0 m
15.0 m	X20CA0E61.0150	POWERLINK connection cable RJ45 to RJ45, 15.0 m
50.0 m	X20CA0E61.0500	POWERLINK connection cable RJ45 to RJ45, 50.0 m

**Ethernet POWERLINK cable  
RJ45 to M12**



Length	Attachment cable Model number	Short description
5 m	X67CA0E41.0050	POWERLINK attachment cable RJ45 to M12, 5.0 m
15 m	X67CA0E41.0150	POWERLINK attachment cable RJ45 to M12, 15.0 m
50 m	X67CA0E41.0500	POWERLINK attachment cable RJ45 to M12, 50.0 m

For detailed information and support: [www.br-automation.com](http://www.br-automation.com)

## Mechanical and electrical configuration

### Dimensions

The dimensions are in 2D with the ECAD macros for CAD support . STEP data is provided for 3D representation.

*The STEP data can be downloaded from the B&R website ([www.br-automation.com](http://www.br-automation.com)) under Services.*

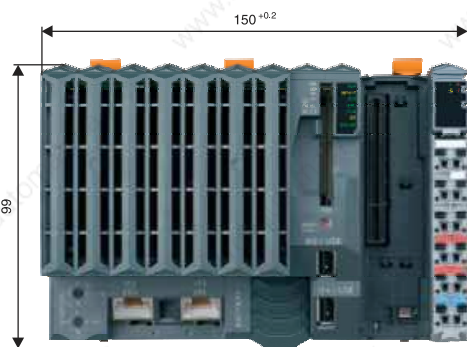

X20 CPUs with one slot for interface modules

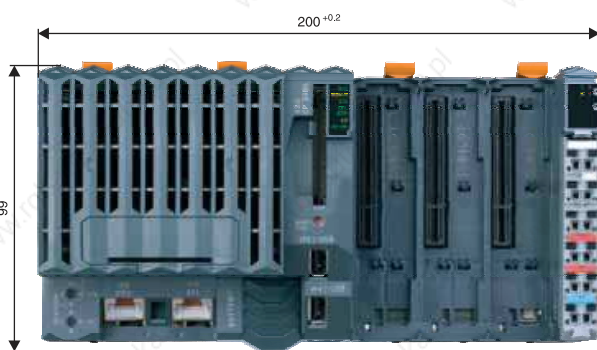

X20 CPUs with three slots for interface modules



Compact CPUs and bus controllers



Fieldbus CPUs and expandable bus controller with one additional slot

## Mechanical and electrical configuration



Fieldbus CPUs and expandable bus controller with two additional slots

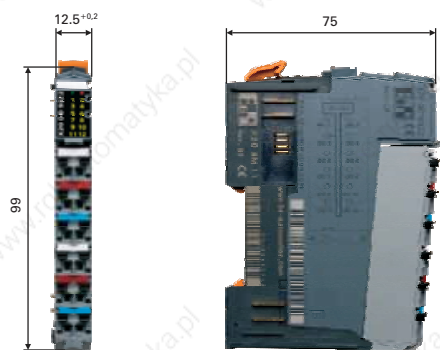

I/O modules

## Construction support

### Macros for ECAD systems

The electronics in a machine must be designed in a manner which optimally utilizes the materials and space available. Graphic ECAD systems have established themselves as the right tool for the job. Every module in the X20 System comes with preset electronic descriptions of the mechanical dimensions, electrical signals and module functions. These macros are loaded directly to well-established ECAD systems. The wiring plans are automatically applied by the configuration and programming system, Automation Studio. Design and changes are immediately reflected at all levels of development. This saves time for the more important tasks and prevents errors right from the start. The accelerated development, programming, maintenance and documentation involved with the X20 System mean lower costs, enhanced quality and increased sales by earlier entry into the market.

### Printing support

System printers and standard identification labels are supported by the appropriate printer software. Printing manually, from table calculations, or directly from ECAD software – all methods are supported. The software and printer systems are from the company Weidmüller.

## Mechanical and electrical configuration

### Installation

A mounting rail conforming to the EN60715 standard (TH35-7.5) is required to mount the PLC. The mounting rail is fastened to the back wall of the switching cabinet.

The entire system including all individual modules is hung in the desired location on the mounting rail with the unlocking mechanisms open and locked in place by closing the unlocking mechanisms. Finally, the prewired terminal blocks are connected to the modules.

**Note:** Mounting orientations other than horizontal and vertical are not possible.

### Horizontal installation

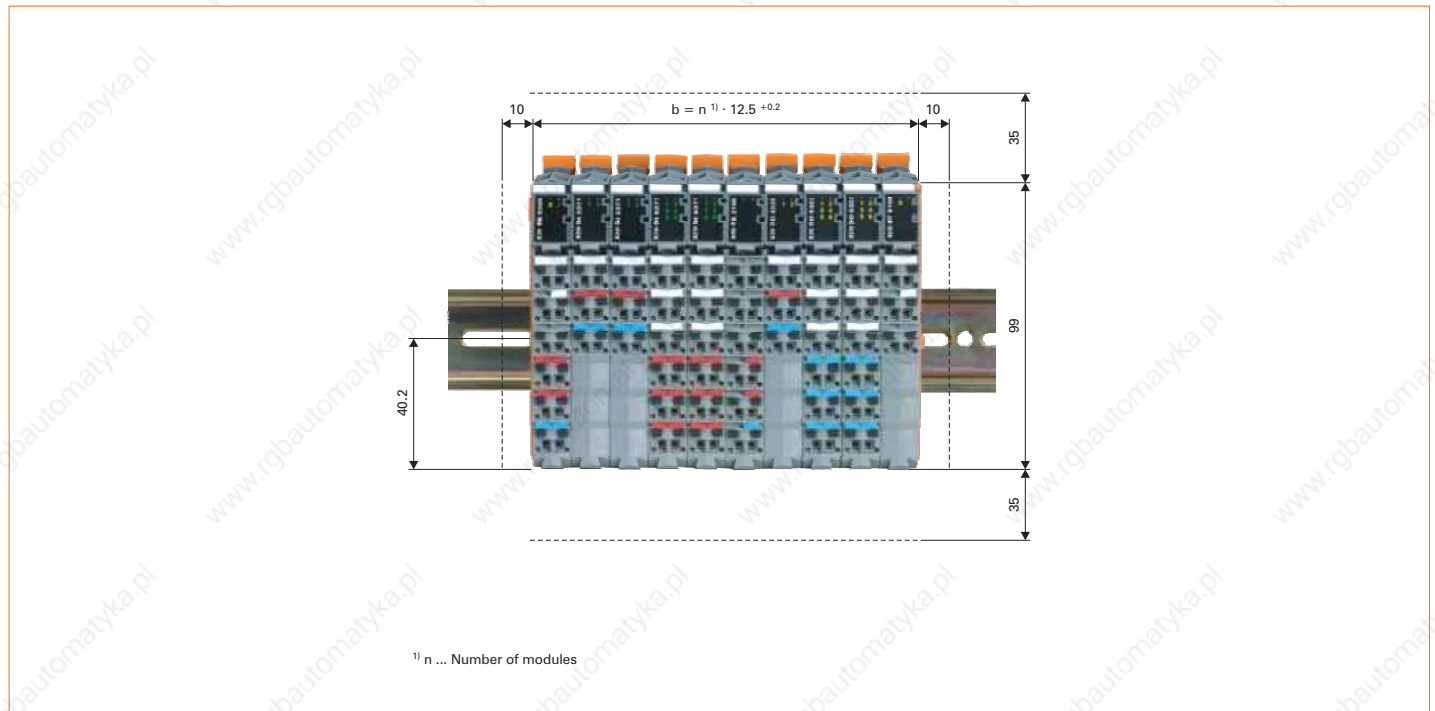

For optimal cooling and air circulation, there must be at least 35 mm free space above the modules. To the left and right of the X20 System, there must be at least 10 mm of free space. Underneath the module, 35 mm space must be left free for the input, output and supply cables.

## Vertical installation

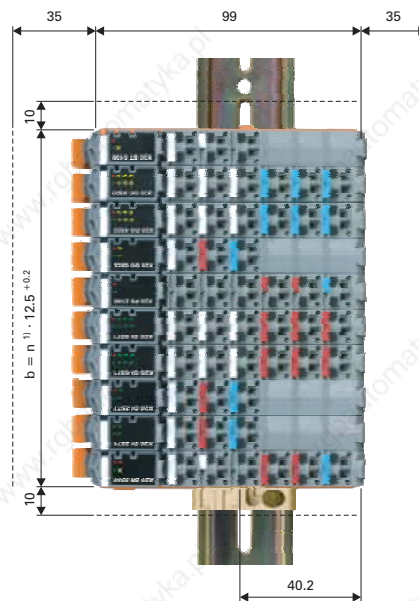

<sup>1)</sup> n ... Number of modules

For optimal cooling and air circulation, there must be at least 35 mm free space to the left of the modules. Above and below the X20 System, there must be at least 10 mm of free space. To the right of the module, 35 mm space must be left free for the input, output and supply cables. The modules must be arranged so that the controller is on the lower end of the system. The temperature range is limited to 0 - 50°C when installing modules vertically.

**Note:** The controller must be secured against slipping. An end bracket or ground terminal can be used for securing.

## Mechanical and electrical configuration



### Stress relief using cable ties

The X20 System terminal blocks have slots for the cable ties. If needed, a cable tie can be fed through these slots to reduce the stress on the cable.

Cable tie dimensions:      Width  $\leq 4.0$  mm  
   Thickness  $\leq 1.2$  mm



Slots through which the cable ties are fed

## Shielding

In principle, the shield must be grounded in all shielded cables:

- Analog signals (In/Out)
- Interface modules
- Counter modules
- X2X Link cable

In general, the following guidelines apply for shielding:

- The X20 mounting rail must always be mounted to a conductive backplane
- Shielded cables must be grounded on both sides

### Direct shielding connection

The shield is twisted and connected to the bus module's ground connection using a cable lug (2.8 x 0.5 mm). The cable is additionally secured to the terminal block using a cable tie (stress relief).

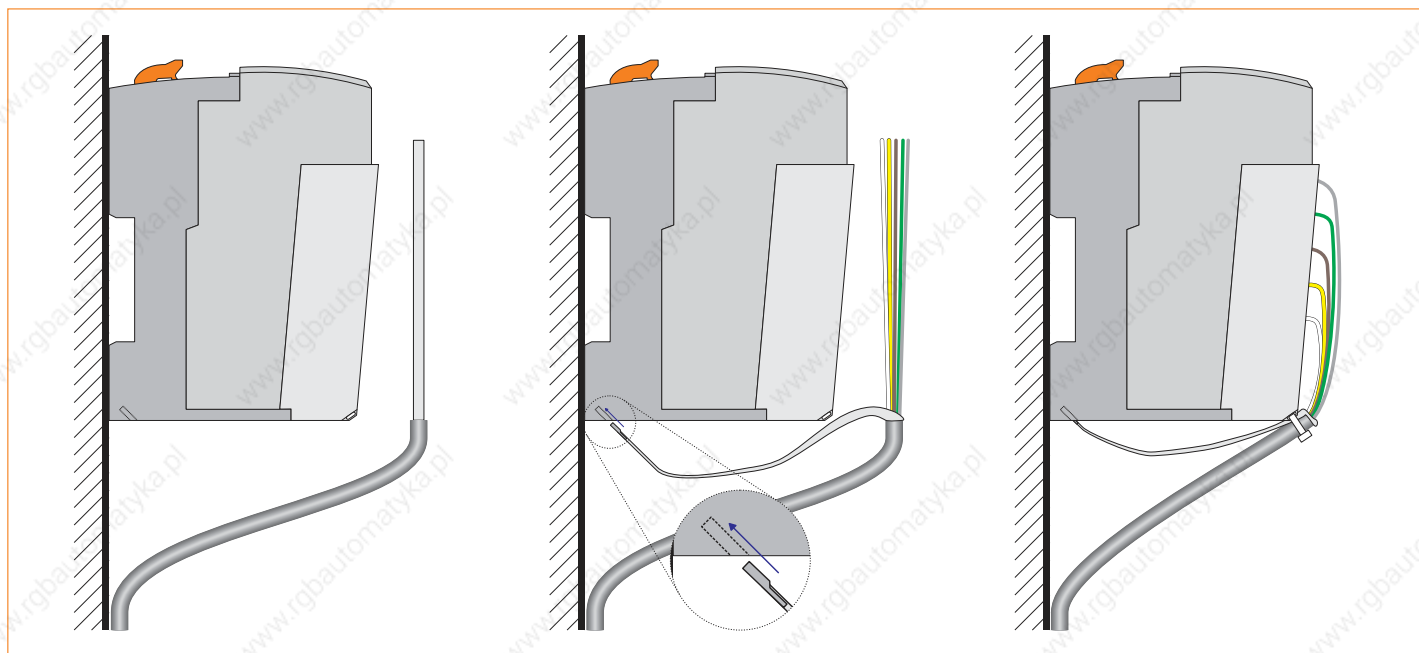

**Note:** The ground connection should be made as short, and with as little resistance, as possible.

## Mechanical and electrical Configuration

### X20 cable shielding plate

The X20 cable shielding plate (available starting in the 3rd quarter 2007, model number X20AC0SG1) is latched to the terminal block and connected to the bus module's ground connection using a cable lug. Cable ties are used to press the shield against the grounding plate.

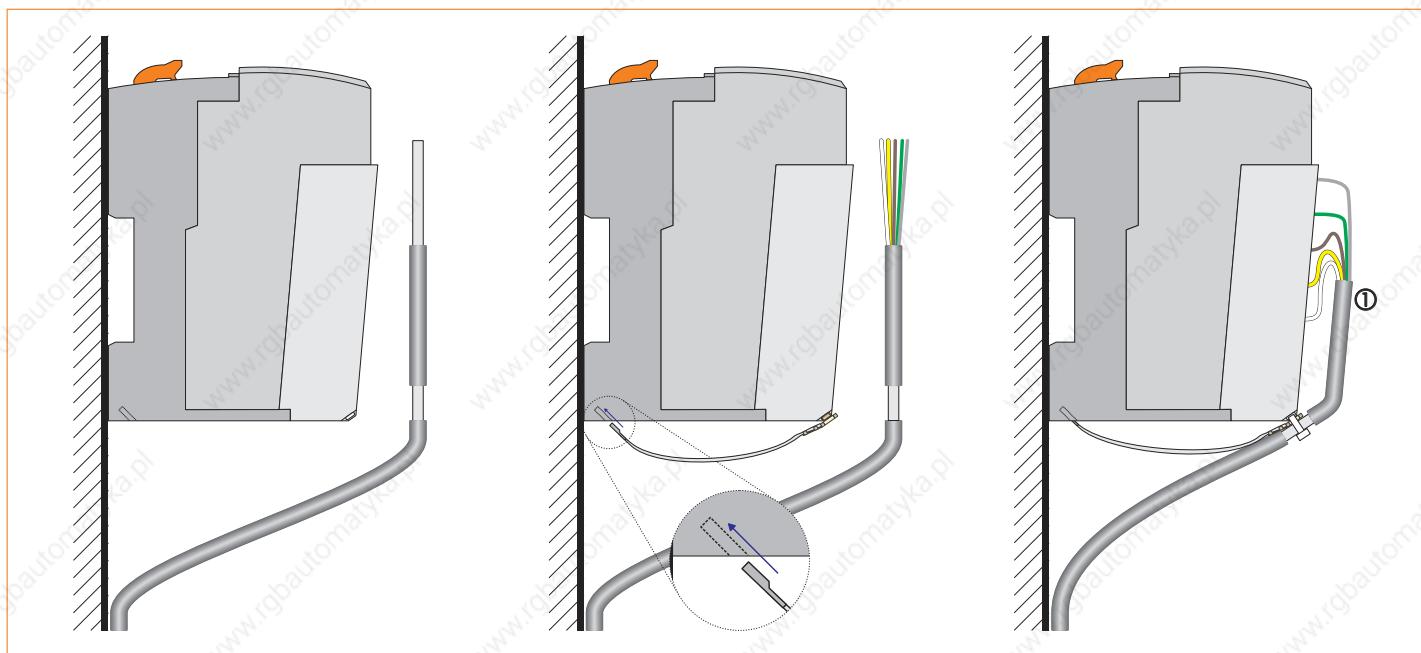

To reduce the EMC emissions most effectively, the cable shield must reach as high as possible after the cable tie (see ① in the diagram above).

### Shielding with grounding terminals

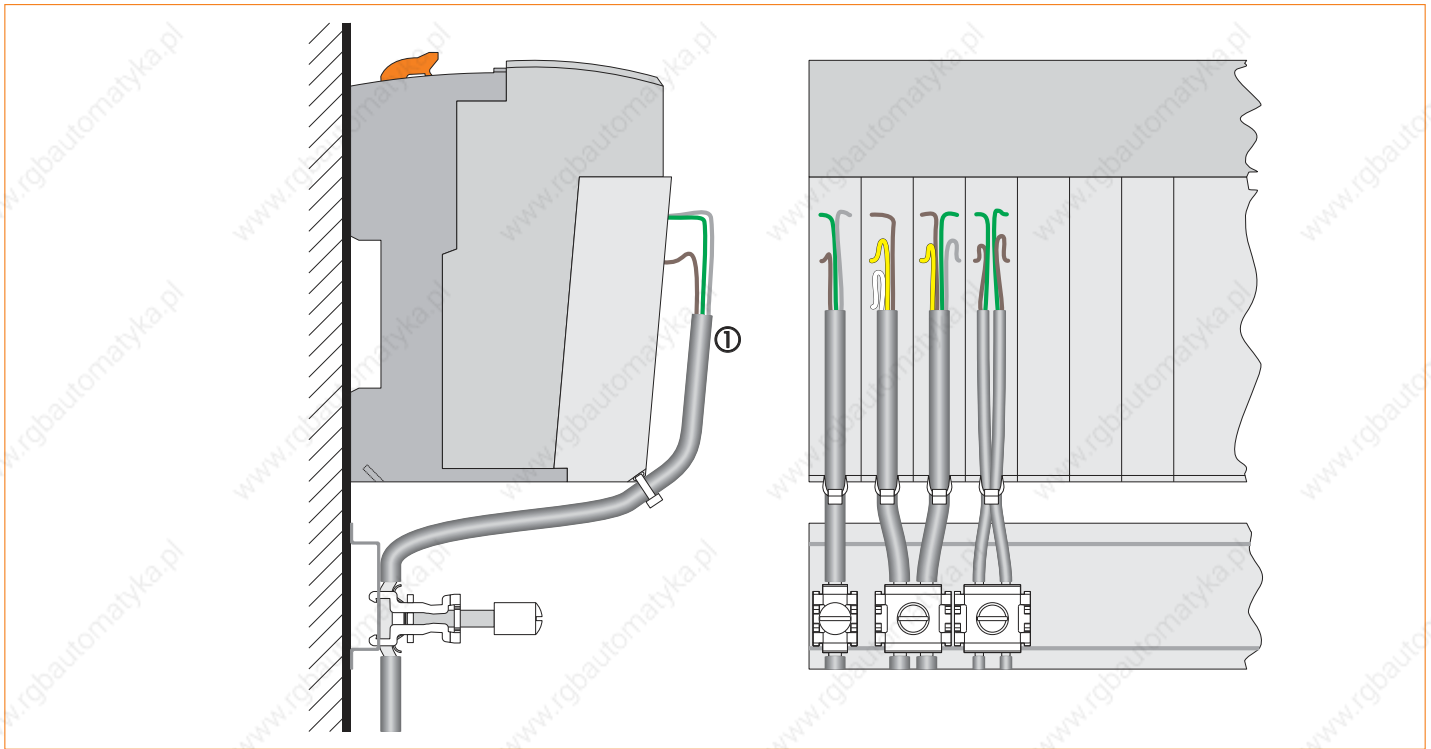

Grounding terminals from other manufacturers (such as GOGATEC) can be used to achieve shielding right on the mounting rail or on special bus bars directly below the controller.

- B&R recommends **always** using a grounding terminal via the mounting rail to connect the X2X Link cable shield directly with the conductive and grounded backplane. This will generally exceed the specified EMC minimal requirements.
- The shielded cables from other modules can be grouped and clamped together. This may also be necessary due to space limitations. A different number of cables can be grounded together with a single terminal depending on the grounding terminals being used.

To reduce the EMC emissions most effectively, the cable shield must reach as high as possible after the cable tie (see ① in the diagram above).

## Mechanical and electrical configuration



### The power supply design

#### Bus module rack replacement

The bus module is the backbone of the X20 System regarding the bus supply and bus data and also the I/O supply for the electronics modules. Each bus module is an active bus station, even without electronics module. There are two variations of the bus module:

- Interconnected I/O supply
- Supply module with the I/O supply isolated to the left



### X20 System infrastructure

Different potential groups can be implemented with the appropriate arrangement of supply bus modules, (e.g. for input groups or different E-stop circuits on the outputs). The I/O supply is fed from supply modules.

### **Bus supply**

The X2X Link supply must be connected in specific locations because the decentralized X2X Link backplane and the I/O electronics are completely electrically isolated. To start, the bus receiver takes on this task. Another supply must be connected after approximately 30<sup>1)</sup> modules. A supply module must be used for the X2X Link. On the same module, a separate feed for the I/O supply can also be connected.

### **Potential groups**

The I/O supply is connected via the bus modules. The feed is connected via corresponding supply modules. This makes it possible to implement simple potential groups (e.g. for input groups or different output groups). For isolation, the corresponding bus module is also necessary, which provides isolation of the internal I/O supply.

### **Output modules with supply**

Generally, a supply module is also necessary for current output modules with many channels such as the 8 channel output module with 2 amp outputs. This is not the case with the X20 System. With this module, the supply feed is directly on the module, thereby saving supply modules and construction width.

### **Bus receiver with supply**

The BR9300 bus receiver for the X20 System is equipped with a feed for the X2X Link as well as the internal I/O supply. This way, no additional supply module is needed.

### **Supply module for internal I/O supply**

The first I/O modules of an X20 System are supplied by the bus receiver. The internal I/O supply is refreshed via the PS2100 supply module.

### **Supply module for internal I/O supply and bus supply**

The X2X Link is fed by the BR9300 bus receiver. After approx. 30<sup>1)</sup> modules, an additional supply must be connected. The PS3300 supply module is used for this purpose. This module is equipped with a feed for the X2X link as well as the internal I/O supply.

### **Bus transmitter with supply**

The BT9100 bus transmitter has an integrated I/O supply feed. This saves a supply module for the last potential group.

1) For an exact calculation, see section "Power output table" (▣ 411).

# Mechanical and electrical configuration

## Safe cut-off

The total separation of the power supply from the communication and I/O makes it possible to safely turn off all outputs in the power circuit with an E-stop switching device without communication being disturbed. The X20 System has been certified and approved for this behavior by the German occupational safety and health commission (Berufsgenossenschaft - BG) in accordance to the following standards:

- DIN EN 954-1 up to Category 4
- DIN EN ISO 13849-1 up to Category 4, Performance level "e"
- DIN EN 62061 up to SILCL 3

The safety level achieved is determined by the safety level of the external safety switching device. The modules and revisions approved for this operating principle must be taken into consideration.

## X20 System protection

The X20 system is protected according to the power supply design.

## Potential groups

Different potential groups can be implemented using the BM01 bus module, and with the appropriate arrangement of supply bus modules, (e.g. for input groups or different power circuits on the outputs).

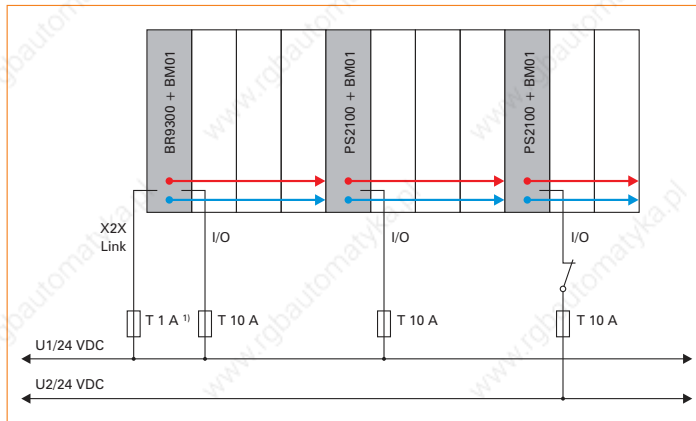

1) Recommended for line protection.



## Supply feed via bus transmitter

The BT9100 bus transmitter has an integrated internal I/O supply feed. This saves a supply module for the last potential group. Keep in mind: this potential group is separated from the rest of the potential groups by an I/O module with the BM01 bus module.

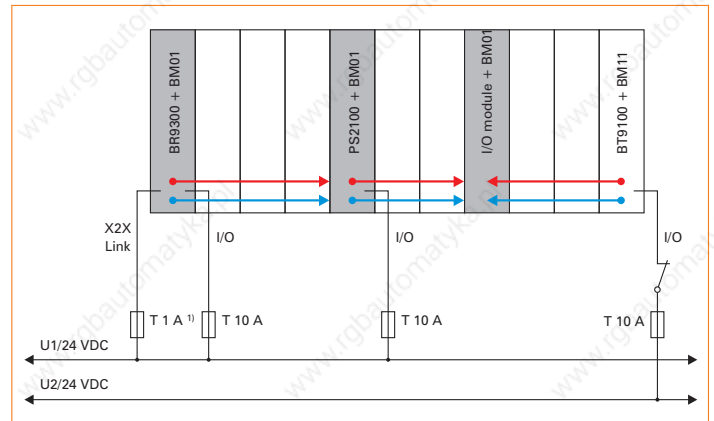

1) Recommended for line protection.

### Expanded and redundant X2X Link supply

The remote backplane X2X Link is supplied separately from the I/O. This ensures that if there is a power outage on the I/O side (e.g. E-stop) the remote backplane will not be affected. After approx. 30 modules, a supply module for the X2X Link must be added.

To provide increased supply protection, it is possible to make the X2X Link supply redundant. To do this, at least one extra X2X supply module than would be needed to provide the required X2X Link performance must be used. This guarantees the function of the remote backplane even when one X2X Link supply goes down.

For proper calculation, note the following point:

- To determine the required X2X Link performance, calculate using 75% of the supply module's rated power, during parallel operation.

**Note:** If the X2X Link supply is not redundant or if the X2X Link supply of an X20 block is shut off completely, this should happen simultaneously for all supply modules.

### Example of expanded X2X Link supply

Potential groups can be formed by the use of different types of supplies for the supply modules.

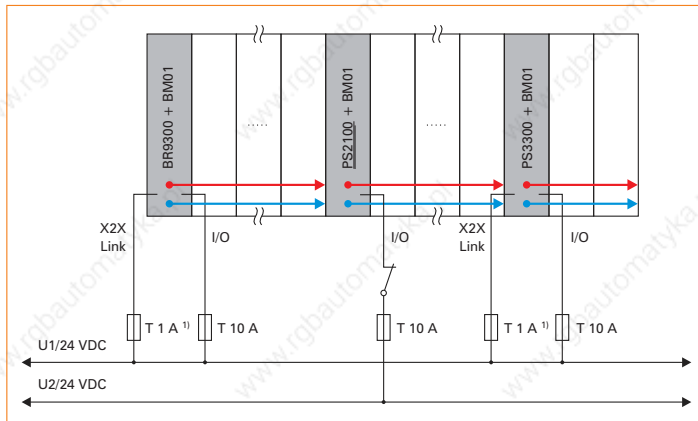

1) Recommended for line protection.

The PS3300 supply module supplies both the X2X Link and I/O, the PS2100 supply module only supplies the I/O.

### Example of redundant X2X Link supply

Multiple PS3300 supply modules can be set up in parallel. Potential groups can be formed by the use of different types of supplies.

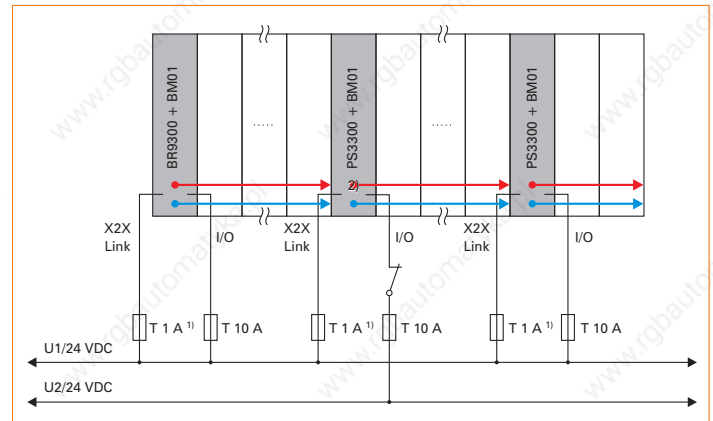

1) Recommended for line protection.

2) With split supplies, the two reference potentials (GND\_1 and GND\_2) are combined via the terminal block of the PS3300.

The PS3300 supply module supplies both X2X Link and the I/O.

# Mechanical and electrical configuration

## Combining X2X Link-based systems

### General information

The X2X Link provides a complete backplane, which is used for communicating between bus modules and over the X2X Link cable. Systems based on X2X Link can be combined with one another as needed.

### Overview of pin connections

The following connection overviews illustrate combinations of different systems that are based on X2X Link. The model numbers indicate which standard cables available from B&R can be used to connect with one another.

## Combining X20, X67 and Compact I/O systems

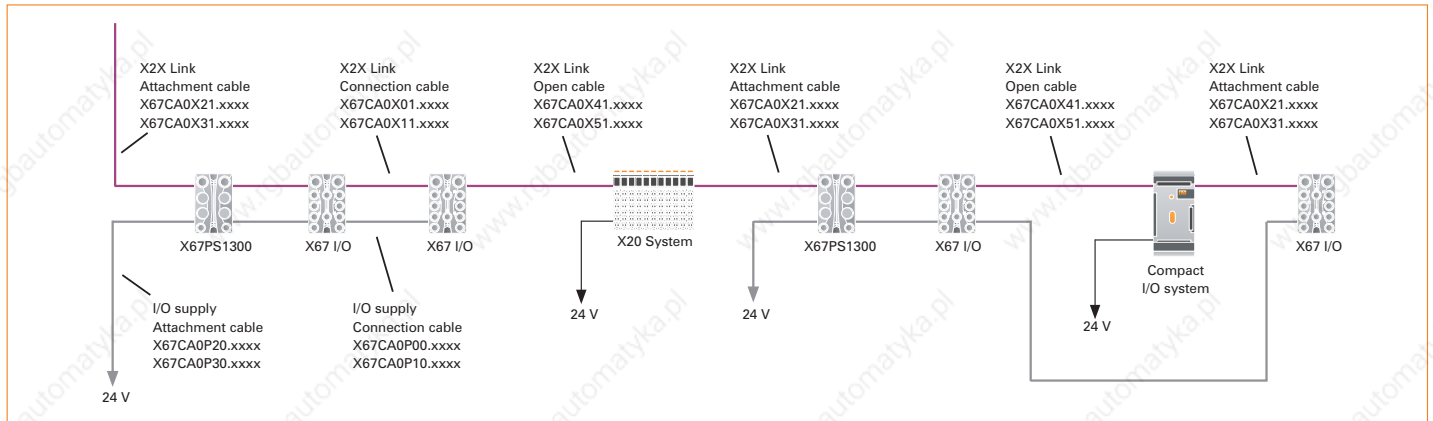

## Combining X20, X67 and valve manifold connections

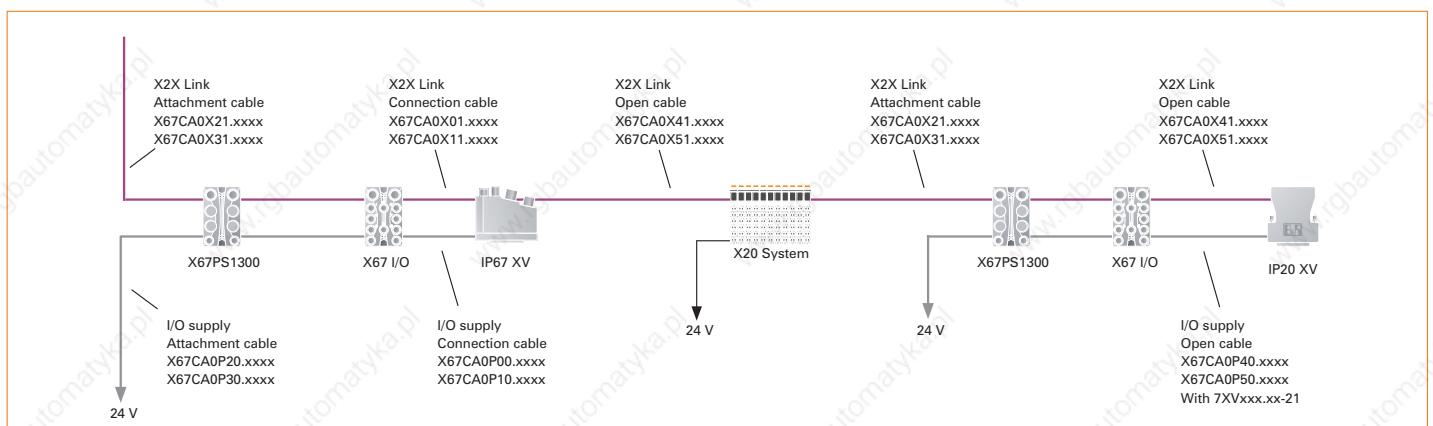

## X20 System - Connection examples

Connection examples can be found under the module description:

- Bus receiver BR9300: 208
- Bus transmitter BT9100: 210

### Connection example for the Compact I/O system

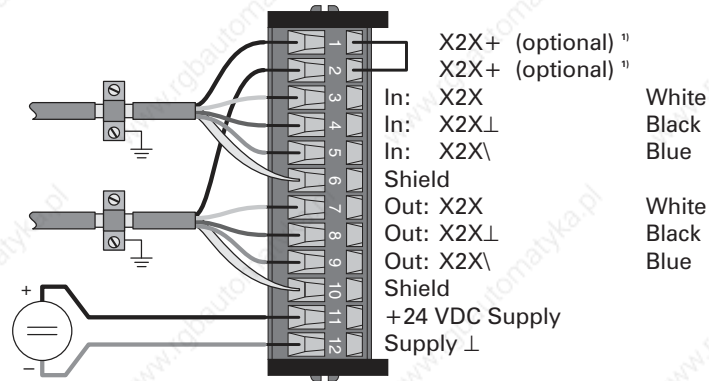

1) Used to forward the X2X Link supply when using IP67 modules.

Signal	Cable type	Model number
X2X Link In	Open cable <sup>1)</sup>	X67CA0X41.xxxx
		X67CA0X51.xxxx
X2X Link Out	Attachment cable <sup>1)</sup>	X67CA0X21.xxxx
		X67CA0X31.xxxx
X2X Link In/Out	Cable for custom prefabrication, 100 m	X67CA0X99.1000

1) Bridge for X2X+ together with X67 modules.

# Mechanical and electrical configuration

## Valve - Connection examples

Connection example with 7XVxxx.xx-11/-12

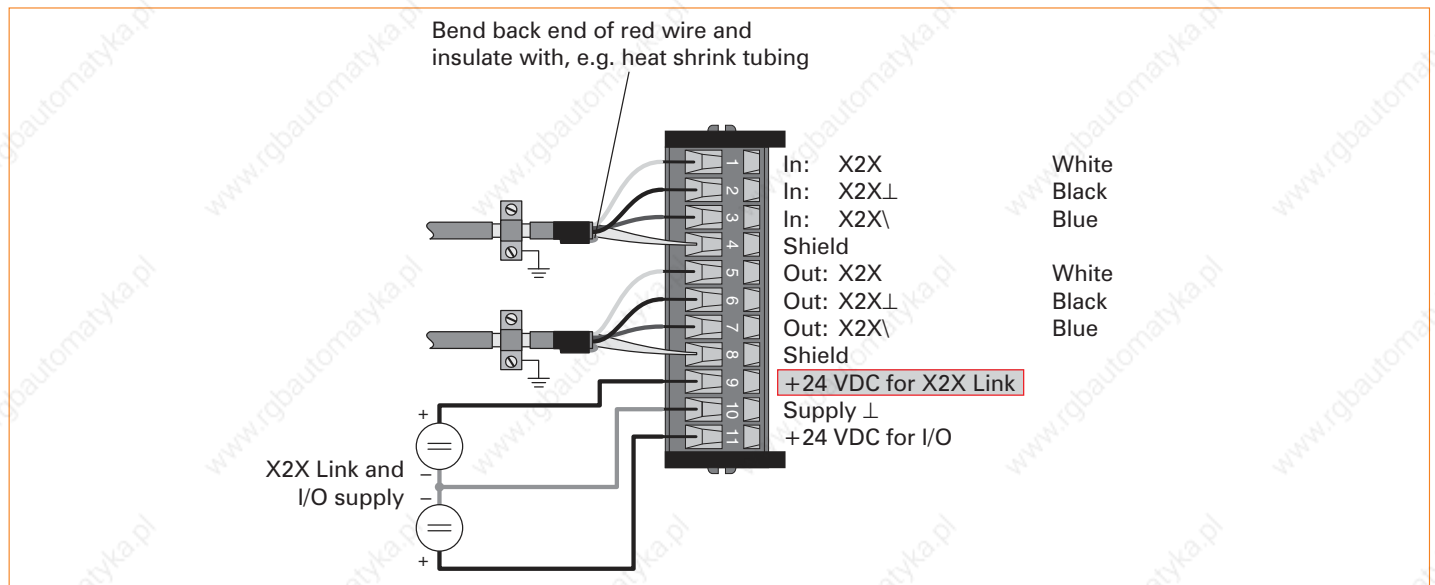

Signal	Cable type	Model number
X2X Link In	Open cable <sup>1)</sup>	X67CA0X41.xxxx X67CA0X51.xxxx
X2X Link Out	Attachment cable <sup>1)</sup>	X67CA0X21.xxxx X67CA0X31.xxxx
X2X Link In/Out	Cable for custom prefabrication, 100 m	X67CA0X99.1000

<sup>1)</sup> In connection with X67 modules.

Connection example with 7XVxxx.xx-21

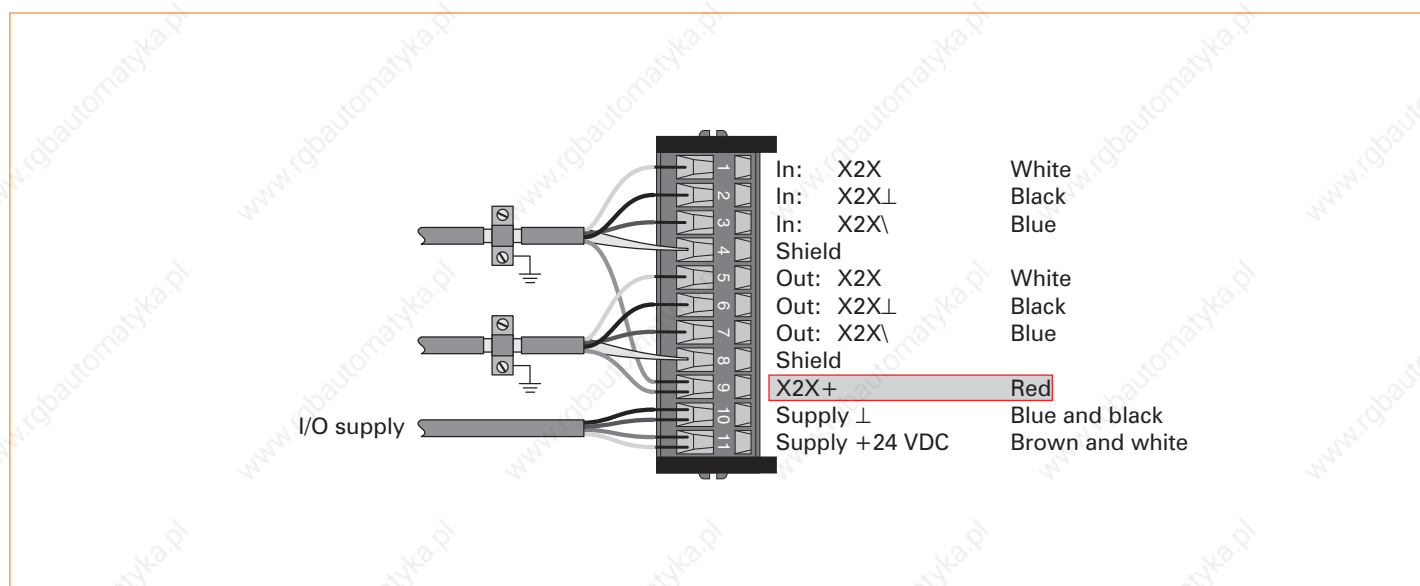

Signal	Cable type	Model number
X2X Link In	Open cable <sup>1)</sup>	X67CA0X41.xxxx X67CA0X51.xxxx
X2X Link Out	Attachment cable <sup>1)</sup>	X67CA0X21.xxxx X67CA0X31.xxxx
X2X Link In/Out	Cable for custom prefabrication, 100 m	X67CA0X99.1000
I/O supply	Open cable <sup>1)</sup>	X67CA0P40.xxxx X67CA0P50.xxxx

<sup>1)</sup> In connection with X67 modules.

## Mechanical and electrical configuration

Connection example with 7XVxxx.xx-51/-62

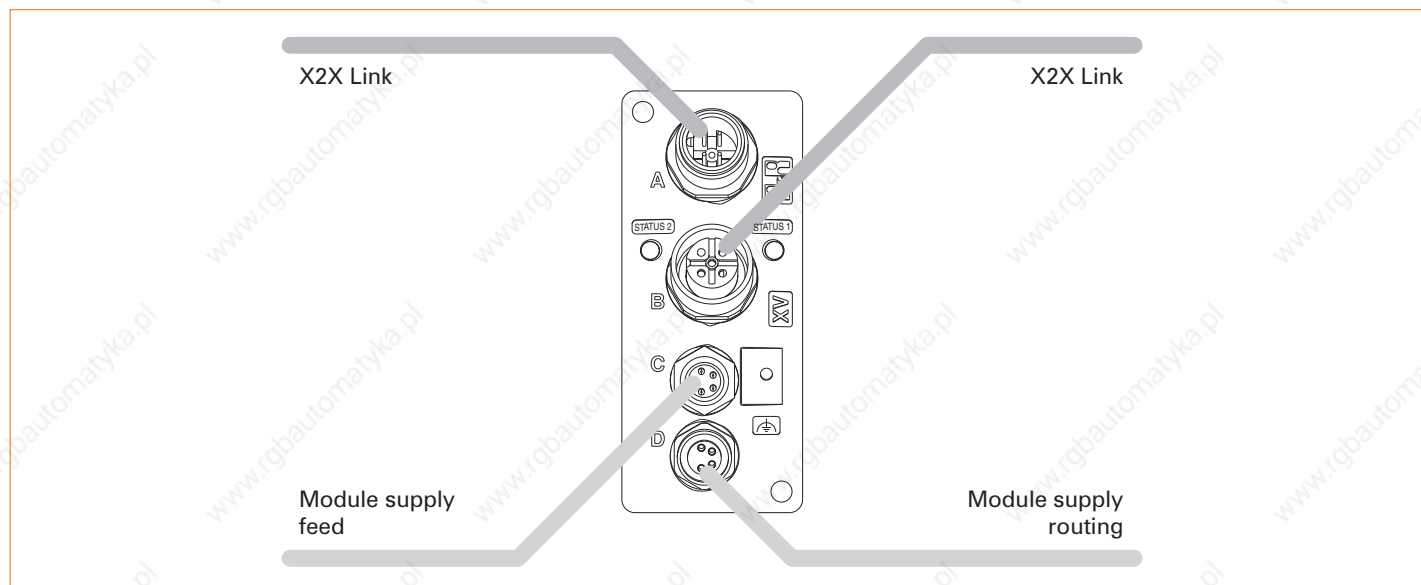

Signal	Cable type	Model number
X2X Link	Connection cable <sup>1)</sup>	X67CA0X01.xxxx X67CA0X11.xxxx
I/O supply	Connection cable <sup>1)</sup>	X67CA0P00.xxxx X67CA0P10.xxxx

<sup>1)</sup> In connection with X67 modules.

## Power output table

The "Bus power" and "Internal I/O power" columns specify values for the power provided by the module or the power required by the module. This allows a power output table to be calculated quickly and easily for a particular hardware configuration.

The values in the "Bus power" column refer to the power table for the X2X Link. The power supplied by the X20 CPU, the bus receiver or the supply module is labeled with "+". The power required by modules is shown with a "-" sign. To calculate the power balance, the positive and negative power values should be added together. The sum may not be less than zero.

The values in the "Internal I/O power" column refer to the internal power requirements of the I/O modules using the 24 VDC I/O supply.

Product ID	Model number	Bus power [W] <sup>1)</sup>	Internal I/O power [W]
AI1744	X20AI1744	-0.01	-1.25
AI2622	X20AI2622	-0.01	-0.8
AI2632	X20AI2632	-0.01	-1.2
AI2632-1	X20AI2632-1	-0.01	-1.2
AI4622	X20AI4622	-0.01	-1.1
AI4632	X20AI4632	-0.01	-1.5
AI4632-1	X20AI4632-1	-0.01	-1.5
AO2622	X20AO2622	-0.01	-1.1
AO2632	X20AO2632	-0.01	-1.2
AO4622	X20AO4622	-0.01	-1.5
AO4632	X20AO4632	-0.01	-1.5
AT2222	X20AT2222	-0.01	-1.1
AT2311	X20AT2311	-0.35	-0.85
AT2402	X20AT2402	-0.01	-0.72
AT4222	X20AT4222	-0.01	-1.1
AT6402	X20AT6402	-0.01	-0.91
BB22	X20BB22	-0.32	-
BB27	X20BB27	-0.53	-
BB32	X20BB32	-0.35	-
BB37	X20BB37	-0.56	-
BB80	X20BB80	-	-
BB81	X20BB81	-	-
BB82	X20BB82	-	-
BC0043	X20BC0043	-1.5	-
BC0053	X20BC0053	-1.5	-
BC0063	X20BC0063	-2.3	-
BC0073	X20BC0073	-1.5	-
BC0083	X20BC0083	-2.0	-
BC0087	X20BC0087	-2.0	-
BC0088	X20BC0088	-2.0	-
BC1083	X20BC1083	-2.0	-
BC8083	X20BC8083	-2.0	-
BC8084	X20BC8084	-2.0	-
BM01	X20BM01	-0.13	-
BM05	X20BM05	-0.13	-
BM11	X20BM11	-0.13	-
BM12	X20BM12	-0.13	-
BM15	X20BM15	-0.13	-
BR9300	X20BR9300	+7.0	+240.0 <sup>2)</sup>
BT9100	X20BT9100	-0.5	-0.1 <sup>4)</sup> / +240 <sup>2) 5)</sup>
BT9400	X20BT9400	-0.5	-0.1 <sup>4)</sup> / +240 <sup>2) 5)</sup>
CM0985	X20CM0985	-1.4	-4.0
CM1201	X20CM1201	-0.01	-1.5

## Mechanical and electrical configuration

Product ID	Model number	Bus power [W] <sup>1)</sup>	Internal I/O power [W]
CM1941	X20CM1941	-0.01	-1.5
CM8281	X20CM8281	-0.01	-1.75
CM8323	X20CM8323	-0.01	-1.5
CP0201	X20CP0201	-2.2	-
CP0291	X20CP0291	-2.7	-
CP0292	X20CP0292	-3.0	-
CP1483	X20CP1483	+7.0	+240.0 <sup>2)</sup>
CP1484	X20CP1484	+7.0	+240.0 <sup>2)</sup>
CP1485	X20CP1485	+7.0	+240.0 <sup>2)</sup>
CP1486	X20CP1486	+7.0	+240.0 <sup>2)</sup>
CP3484	X20CP3484	+7.0	+240.0 <sup>2)</sup>
CP3485	X20CP3485	+7.0	+240.0 <sup>2)</sup>
CP3486	X20CP3486	+7.0	+240.0 <sup>2)</sup>
CS1011	X20CS1011	-0.01	-1.0
CS1020	X20CS1020	-0.01	-1.44
CS1030	X20CS1030	-0.01	-1.44
CS1070	X20CS1070	-0.01	-1.44
CS2770	X20CS2770	-0.01	-1.5
DC1196	X20DC1196	-0.01	-1.5
DC1198	X20DC1198	-0.01	-1.5
DC1396	X20DC1396	-0.01	-1.4
DC1398	X20DC1398	-0.01	-1.3
DC2190	X20DC2190	-0.01	-1.1
DC2395	X20DC2395	-0.01	-1.4
DC2396	X20DC2396	-0.01	-1.5
DC2398	X20DC2398	-0.01	-1.4
DC4395	X20DC4395	-0.01	-1.5
DI2371	X20DI2371	-0.12	-0.29
DI2372	X20DI2372	-0.12	-0.29
DI2377	X20DI2377	-0.15	-0.82
DI2653 <sup>3)</sup>	X20DI2653	-0.14	-
DI4371	X20DI4371	-0.14	-0.59
DI4372	X20DI4372	-0.14	-0.59
DI4653 <sup>3)</sup>	X20DI4653	-0.17	-
DI4760	X20DI4760	-0.01	-1.5
DI6371	X20DI6371	-0.15	-0.88
DI6372	X20DI6372	-0.15	-0.88
DI6553 <sup>3)</sup>	X20DI6553	-0.21	-
DI8371 <sup>3)</sup>	X20DI8371	-0.18	-
DI9371 <sup>3)</sup>	X20DI9371	-0.18	-
DI9372	X20DI9372	-0.18	-1.75
DM9324 <sup>3)</sup>	X20DM9324	-0.21	-0.5
DO2321	X20DO2321	-0.13	-0.3
DO2322	X20DO2322	-0.13	-0.33
DO2623 <sup>3)</sup>	X20DO2623	-0.35	-
DO2649	X20DO2649	-0.45	-
DO4321	X20DO4321	-0.16	-0.49
DO4322	X20DO4322	-0.16	-0.49
DO4331	X20DO4331	-0.16	-0.49
DO4332	X20DO4332	-0.16	-0.5
DO4529	X20DO4529	-0.8	-
DO4623 <sup>3)</sup>	X20DO4623	-0.52	-
DO6321	X20DO6321	-0.2	-0.59
DO6322	X20DO6322	-0.18	-0.71

Product ID	Model number	Bus power [W] <sup>1)</sup>	Internal I/O power [W]
DO6529	X2DO6529	-1.1	-
DO8322	X2DO8322	-0.26	-0.8
DO8331 <sup>3)</sup>	X2DO8331	-0.22	-
DO8332 <sup>3)</sup>	X2DO8332	-0.22	-
DO9321	X2DO9321	-0.26	-0.99
DO9322	X2DO9322	-0.26	-1.15
DS1119	X2DS1119	-0.01	-1.5
DS1319	X2DS1319	-0.01	-1.5
HB2880	X20HB2880	TBD	-
HB2885	X20HB2885	TBD	-
IF1020	X20IF1020	-0.33	-
IF1030	X20IF1030	-0.4	-
IF1061	X20IF1061	-1.4	-
IF1063	X20IF1063	-0.87	-
IF1072	X20IF1072	-0.79	-
IF1074	X20IF1074	-0.69	-
IF1082	X20IF1082	-2.0	-
IF1091	X20IF1091	-0.97	-
IF1091-1	X20IF1091-1	-1.29	-
IF2772	X20IF2772	-1.2	-
IF2792	X20IF2792	-1.51	-
MM2436 <sup>3)</sup>	X20MM2436	-0.01	-
MM4456 <sup>3)</sup>	X20MM4456	-0.01	-2.0
PD0011 <sup>3)</sup>	X20PD0011	-0.12	-
PD0012	X20PD0012	-0.12	-1.0
PD0016 <sup>3)</sup>	X20PD0016	-0.12	-
PD2113 <sup>3)</sup>	X20PD2113	-0.12	-
PS2100	X20PS2100	-0.2	+240.0 <sup>2)</sup>
PS2110	X20PS2110	-0.2	+240.0 <sup>2)</sup>
PS3300	X20PS3300	+7.0	+240.0 <sup>2)</sup>
PS3310	X20PS3310	+7.0	+240.0 <sup>2)</sup>
PS4951	X20PS4951	-0.01	-1.80
PS9400	X20PS9400	+7.0	+240.0 <sup>2)</sup>
PS9402	X20PS9402	+7.0	+240.0 <sup>2)</sup>
PS9500	X20PS9500	+7.0	+240.0 <sup>2)</sup>
PS9502	X20PS9502	+7.0	+240.0 <sup>2)</sup>
SM1426	X20SM1426	-0.01	-1.8
SM1436 <sup>3)</sup>	X20SM1436	-0.01	-
XC0201	X20XC0201	-2.0	-
XC0202	X20XC0202	-2.2	-
XC0292	X20XC0292	-2.8	-

For modules with 0.01 W power requirement, the embedded parameter chip can only be read if the I/O supply is also present.

The embedded parameter chip is described in the section "Embedded parameter chip", on page 53.

2) Rated power at 24 VDC and 10.0 A.

3) The module's power consumption can be found on the technical data sheet.

4) When used as bus transmitter.

5) When used as bus transmitter and I/O supply module.

Note: Please observe the example calculations on the following pages.

# Mechanical and electrical configuration

## Example 1

Calculation of the power output table for the bus and 24 VDC I/O supply with the following hardware configuration:

Module	Bus power [W]	Internal I/O power [W]	External I/O power [W]	Sensor/actuator supply [W] <sup>1)</sup>
DI4371	0.14	0.59	-	12
DI2371	0.12	0.29	-	12
DO4322	0.16	0.49	48 <sup>2)</sup>	12
DO4322	0.16	0.49	48 <sup>2)</sup>	12
BT9100	0.5	0.1	-	-
<b>Subtotal</b>		<b>1.96</b>	<b>96</b>	<b>48</b>
<b>Sum</b>	<b>1.08</b>	<b>145.96 (= 1.96 + 96 + 48)</b>		

1) Rated power at 24 VDC and 0.5 A.

2) Rated power at 24 VDC and 100% simultaneousness.

The total power to be supplied by the 24 VDC I/O supply is 145.96 W. One supply module is already integrated in the BR9300 bus receiver. The power comparison indicates that the power provided by the supply module is sufficient.

	Bus power [W]	24 VDC I/O supply power [W]
BR9300	+7.0	+240.0 <sup>1)</sup>
Power required by I/O modules	-1.08	-145.96
Power required by all bus modules	-0.78	-
<b>Residual power</b>	<b>+5.14</b>	<b>+94.04</b>

1) Rated power at 24 VDC and 10.0 A.

## Example 2

In this example, the I/O modules are separated into three potential groups:

- Potential group 1: Digital input modules
- Potential group 2: Digital output modules
- Potential group 3: Analog input modules and temperature modules

Calculation of the power output table for the bus and 24 VDC I/O supply for each potential group with the following hardware configuration:

Potential group 1				
Module	Bus power [W]	Internal I/O power [W]	External I/O power [W]	Sensor/actuator supply [W] <sup>1)</sup>
DI6371	0.15	0.88	-	-
DI6371	0.15	0.88	-	-
DI2377	0.15	0.82	-	12
<b>Subtotal</b>		<b>2.58</b>	-	<b>12</b>
<b>Sum</b>	<b>0.45</b>	<b>14.58 (= 2.58 + 12)</b>		

1) Rated power at 24 VDC and 0.5 A.

Potential group 2				
Module	Bus power [W]	Internal I/O power [W]	External I/O power [W] <sup>1)</sup>	Sensor/actuator supply [W] <sup>2)</sup>
DO2322	0.13	0.33	24	12
DO6322	0.18	0.71	72	-
DO8332	0.22	-	- <sup>3)</sup>	-
<b>Subtotal</b>		<b>1.04</b>	<b>96</b>	<b>12</b>
<b>Sum</b>	<b>0.53</b>	<b>109.04 (= 1.04 + 96 + 12)</b>		

1) Rated power at 24 VDC and 100% simultaneousness.

2) Rated power at 24 VDC and 0.5 A.

3) The power supply is integrated in the module.

Potential group 3				
Module	Bus power [W]	Internal I/O power [W]	External I/O power [W]	Sensor/actuator supply [W]
AI4622	0.01	1.1	-	-
AI4622	0.01	1.1	-	-
AT4222	0.01	1.1	-	-
AT2402	0.01	0.72	-	-
BT9100	0.5	0.1	-	-
<b>Subtotal</b>		<b>4.12</b>	-	-
<b>Sum</b>	<b>0.54</b>	<b>4.12</b>		

## Mechanical and electrical configuration

Next, a power comparison must be made between the power required by the I/O modules and the power delivered by the supply modules.

Potential group 1 is supplied by the supply module integrated in the BR9300 bus receiver. The total power to be supplied by all the bus modules is 3.34 W. The total power to be supplied by the 24 VDC I/O supply for potential group 1 is 14.3 W.

The power comparison indicates that the power provided by the supply module integrated in the BR9300 is sufficient.

Potential group 1	Bus power [W]	24 VDC I/O supply power [W]
BR9300	+7.0	+240.0 <sup>1)</sup>
Power required by I/O modules	-1.22 <sup>2)</sup>	-14.58 <sup>3)</sup>
Power required by all bus modules	-1.82	-
<b>Residual power</b>	<b>+3.96</b>	<b>+225.42</b>

1) Rated power at 24 VDC and 10.0 A.

2) Bus power to be supplied for all I/O modules.

3) 24 VDC I/O supply to be provided for potential group 1.

In potential groups 2 and 3, the 24 VDC I/O supply is fed via the PS2100 supply module. A supply module is required for each potential group.

The power comparison indicates that the power provided by the PS2100 is sufficient.

Potential group 2	24 VDC I/O supply power [W]
PS2100	+240.0 <sup>1)</sup>
Power required by I/O modules	-109.04
<b>Residual power</b>	<b>+130.96</b>

1) Rated power at 24 VDC and 10.0 A.

Potential group 3	24 VDC I/O supply power [W]
PS2100	+240.0 <sup>1)</sup>
Power required by I/O modules	-4.12
<b>Residual power</b>	<b>+235.88</b>

1) Rated power at 24 VDC and 10.0 A.

