

Fast Recovery Rectifier

1N3899 — 1N3903

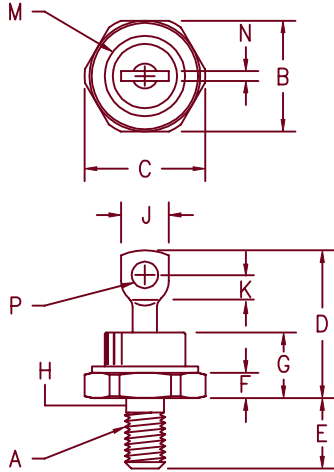

- Notes:
1. 1/4-28 UNF3A threads
 2. Full threads within 2 1/2 threads
 3. Standard Polarity: Stud is Cathode

Dim.	Inches		Millimeter		Notes
	Minimum	Maximum	Minimum	Maximum	
A	---	---	---	---	1
B	.669	.688	16.99	17.48	
C	---	.794	---	20.16	
D	.750	1.000	19.05	25.40	
E	.422	.453	10.72	11.51	
F	.115	.200	2.92	5.08	
G	---	.450	---	11.43	
H	.220	.249	5.58	6.32	2
J	.250	.375	6.35	9.53	
K	.156	---	3.96	---	
M	---	.667	---	16.94	Dia.
N	.030	.080	.760	2.03	
P	.140	.175	3.56	4.45	Dia.

DO203AB (D05)

Microsemi Catalog Number	Working Peak Reverse Voltage	Repetitive Peak Reverse Voltage
1N3899*	50V	50V
1N3900*	100V	100V
1N3901*	200V	200V
1N3902*	300V	300V
1N3903*	400V	400V

*Add the Suffix R for reverse polarity

- Fast Recovery Rectifier
- 150°C Junction Temperature
- 20 Amp current rating
- VRRM 50 to 400 Volts

Electrical Characteristics

Average forward current	$I_F(AV)$ 20 Amps	$T_C = 100^\circ\text{C}$, Square wave, $R_{\theta JC} = 1.8^\circ\text{C/W}$
Maximum surge current	I_{FSM} 225 Amps	8.3 ms, half_sine $T_C = 100^\circ\text{C}$
Max peak forward voltage	V_{FM} 1.40 Volts	$I_{FM} = 63\text{A}$ $T_J = 25^\circ\text{C}^*$
Max peak reverse current	I_{RM} 6 mA	V_{RRM} , $T_J = 150^\circ\text{C}$
Max peak reverse current	I_{RM} 50 μA	V_{RRM} , $T_J = 25^\circ\text{C}$
Max reverse recovery time	t_{RR} 200 ns	$I_F = 1\text{A}$ dc, $V_R = 30\text{V}$, $di/dt = 25\text{A}/\mu\text{s}$
Max junction capacitance	C_J 150 pF	$V_R = 10\text{V}$, $f = 1\text{Mhz}$, $T_J = 25^\circ\text{C}$

*Pulse test: Pulse width 300 μsec , Duty cycle 2%

Thermal and Mechanical Characteristics

Storage temp range	T_{STG}	-65°C to 175°C
Operating junction temp range	T_J	-65°C to 150°C
Max thermal resistance	$R_{\theta JC}$	1.8°C/W Junction to case
Mounting torque		25-30 inch pounds
Weight		.54 ounces (15.3 grams) typical

1N3899 — 1N3903

Figure 1
Typical Forward Characteristics

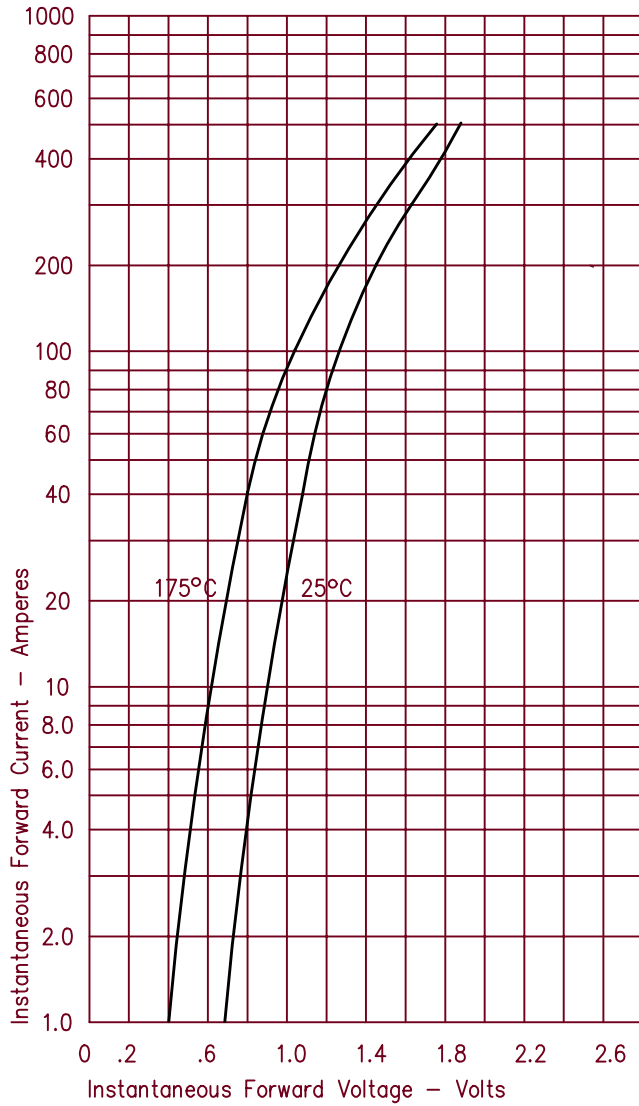

Figure 3
Typical Junction Capacitance

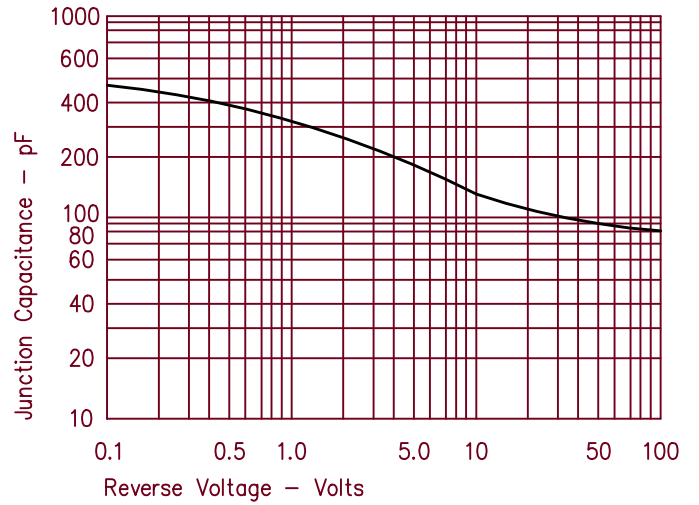

Figure 4
Forward Current Derating

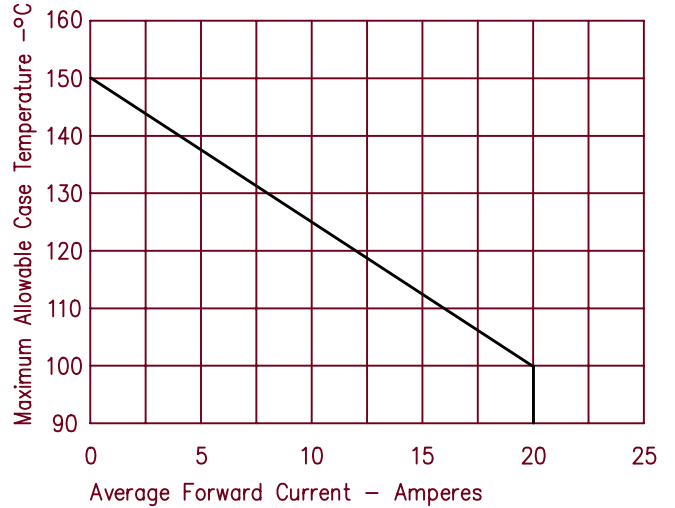
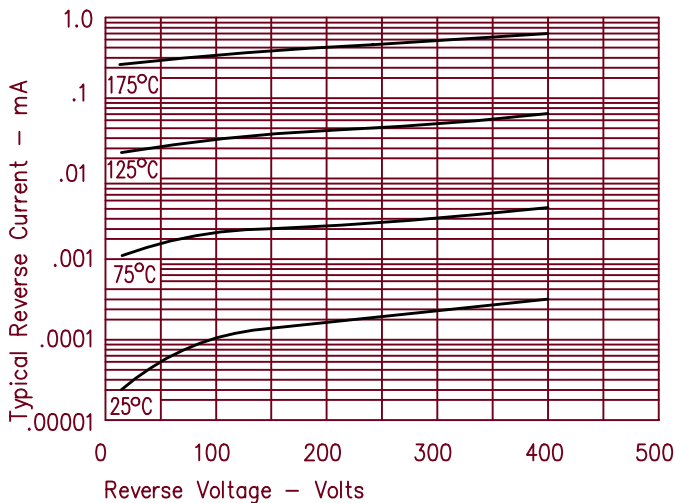

Figure 2
Typical Reverse Characteristics



This datasheet has been download from:

www.datasheetcatalog.com

Datasheets for electronics components.