

Aufstellungsanweisung Installation Instructions Notice de montage

S 201 **S 202**
S 205 **S 254**
S 252 **S 265**
S 253
S 256

AWA 27-510 (12/83)

Frontstecker
Front plug
Connecteurs avant

Frontstecker für Ein- und Ausgabebaugruppen
24 V DC

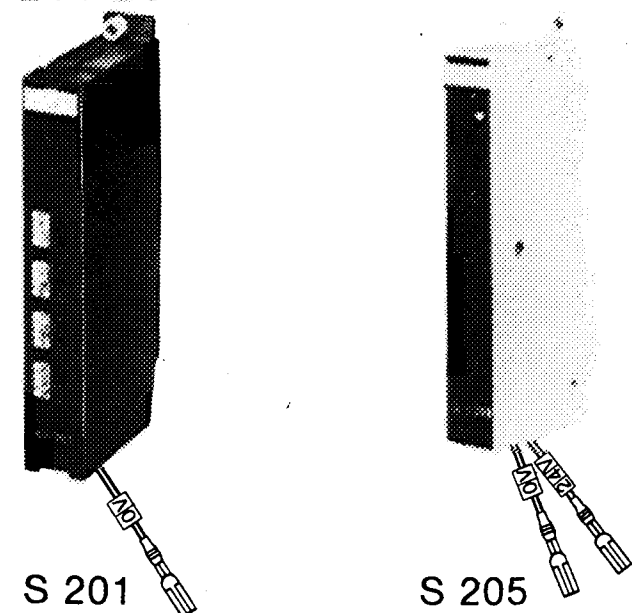

24 V DC

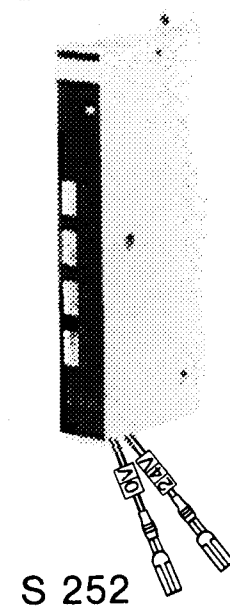

Front plug for input and output cards
24 V DC

24 V DC

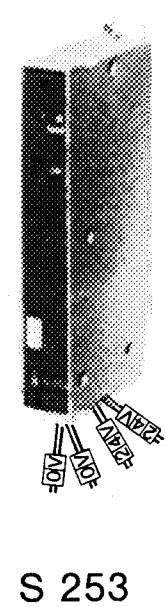

110/220 V AC

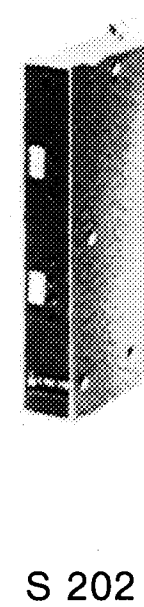

Connecteurs avant pour modules d'entrée-sortie
110/220 V AC

110/220 V AC

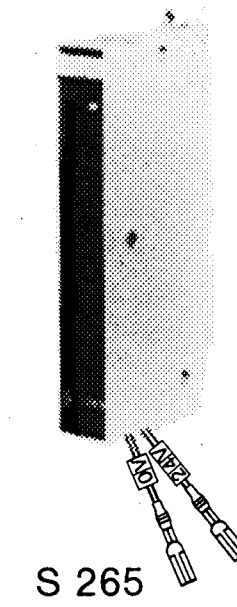
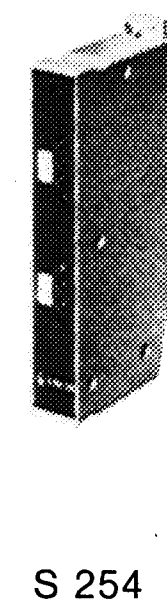

Steckertyp Plug type Type de connecteur	Baugruppentyp Card type Type de module EBE	Nummer der Kontaktkammer Contact slot number Numéro des alvéoles de contact	Baugruppe Anschlußkontakte Card contacts Repère des connexions du module			
			VL	EL	24 V	0 V
S 201 (Input)	200 und 201	0/0, 1/1, 2/2, 3/3, 4/4, 5/5, 6/6, 7/7, 8/8, 9/9, 10/10, 11/11, 12/12, 13/13, 14/14, 15/15	16	16	-	1
S 205 (Input)	205	1/-, 2/Pt+, 3/Pt1, 4/Pt2, 5/I, 6/U, 7/L-	Je nach Betriebsart		1	1
S 252 (Output)	250 und 252	0/0, 1/1, 2/2, 3/3, 4/4, 5/5, 6/6, 7/7, 8/8, 9/9, 10/10, 11/11, 12/12, 13/13, 14/14, 15/15	16	16	1	1
S 253 (Output)	251 und 253	12/Q0, 13/Q1, 14/Q2, 15/Q3	4	4	2	2
S 256 (Output)	256	0/0, 2/1, 4/2, 6/3, 8/4, 10/5, 12/6, 14/7	8	8	1	1
Hinweis für S 256: Als Vielfachleitung VL...-bl-16 verwenden. Die übrigen Adern sind abzuschneiden			0 V ext = Bezugspotential 0 V des +24 V-Laststromversorgungsteil			
S 202 (Input)	202 ...	1/-, 2/0, 3/1, 4/2, 5/3, 6/N, 7/4, 8/5, 9/6, 10/7, 11/-	9	9	-	-
S 254 (Output)	254 ... und 255	1/L1.1, 2/0, 3/1, 4/2, 5/3, 6/N, 7/L1.2, 8/4, 9/5, 10/6, 11/7	11	11	-	-
	254-4 ...	1/L1.1, 2/-, 3/1, 4/2, 5/-, 6/N, 7/L1.2, 8/4, 9/-, 10/-, 11/7	7	7	-	-
S 205 (Output)	255	S 254	+24 V-, 0 V-Leitungen entfernen (Bild 4: Herausnahme von Leitungen)			
S 265 (Output)	265	0/0.1, 1/0.4, 2/1.1, 3/1.4, 4/2.1, 5/2.4, 6/3.1, 7/3.4, 8/4.1, 9/4.4, 10/5.1, 11/5.4, 12/6.1, 13/6.4, 14/7.1, 15/7.4	16	16	1	1
Hinweis: Für S 202 und S 254 (EBE 254-4) sind bei VL 11 Adern. Die übrigen Adern sind abzuschneiden. Note: There are 11 cores on the VL for S 202 and S 254 (EBE 254-4). The remaining cores should be cut off. Nota: Pour S 202 et S 254 (EBE 254-4), le câble VL comporte 11 conducteurs. Supprimer les autres conducteurs.			VL Vielfachleitung Multiple wires Câble multibrins	EL Einzelleitung Single wires Câble unifilaire	24V, 0V Stromversorgung Power supply Alimentation	

Verdrahtungsbeispiel am S 252
Example of wiring on S 252
Exemple de câblage du S 252

Kontakt fest einrasten,
 sonst Rastfeder nachbiegen!
 Push contact home fully,
 or retaining springs may be weakened.
 Bien encliqueter le contact pour
 éviter le cintrage du ressort.

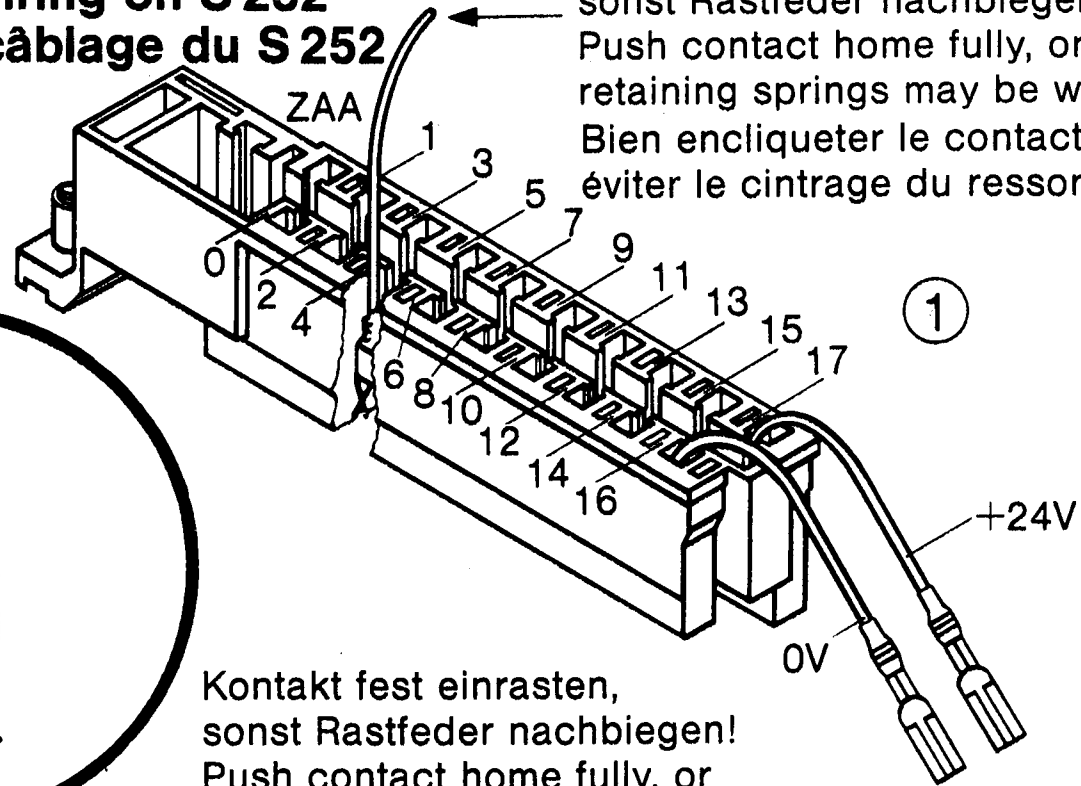
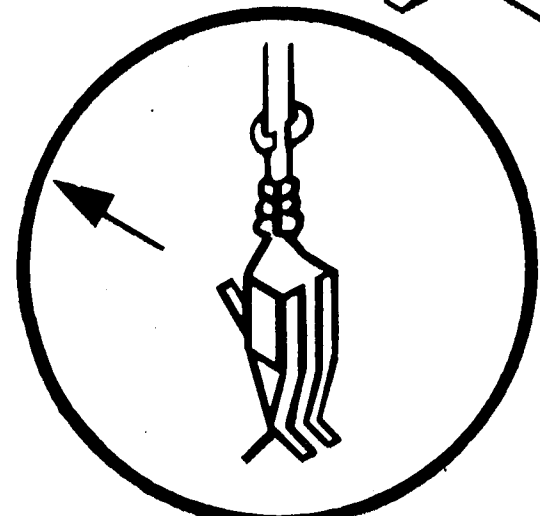

Kontakt fest einrasten,
 sonst Rastfeder nachbiegen!
 Push contact home fully,
 or retaining springs may be weakened.
 Bien encliqueter le contact pour
 éviter le cintrage du ressort.

Nur bei
 Only on
 Seulement
 S 252
 S 253
 S 256

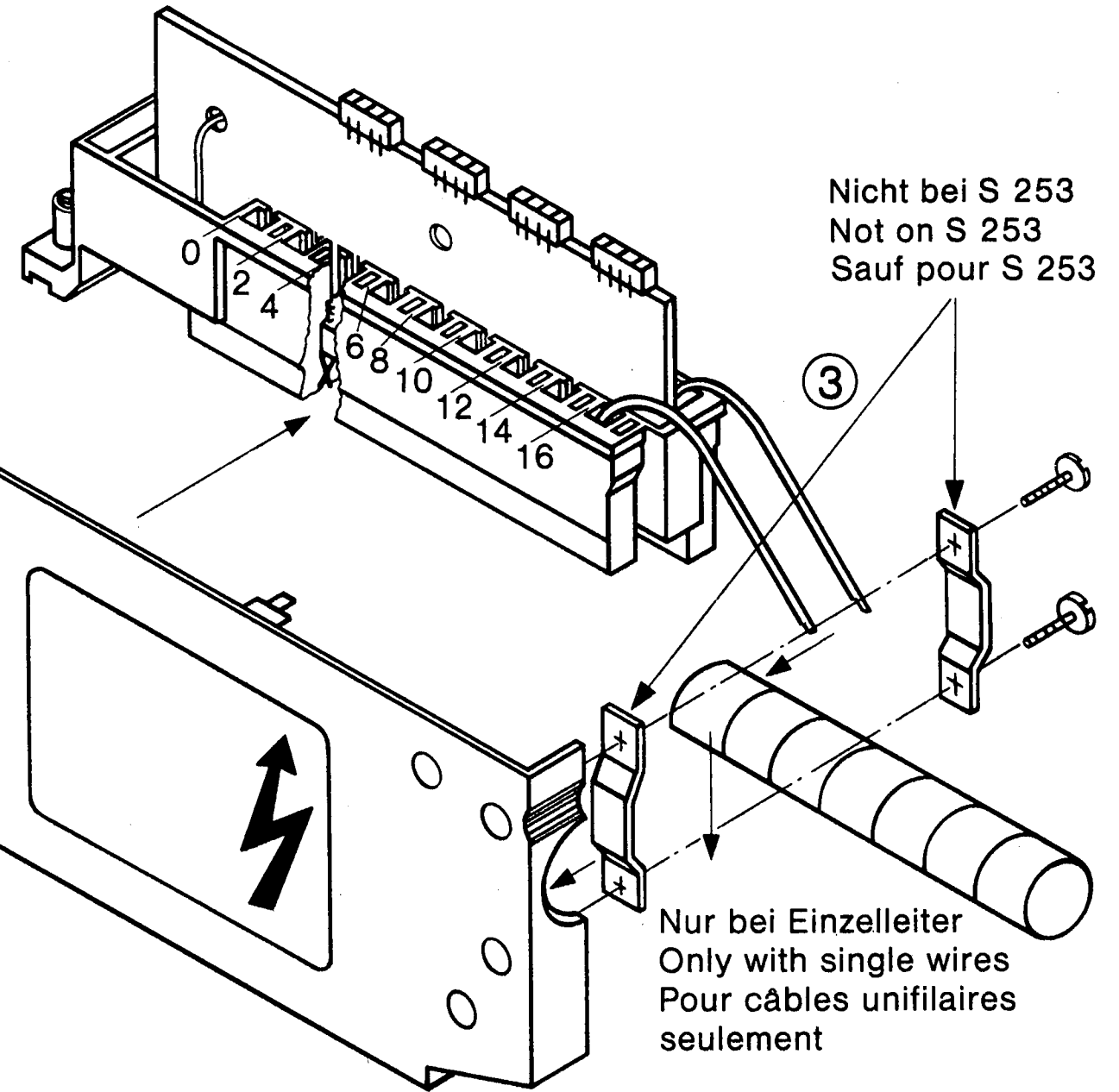
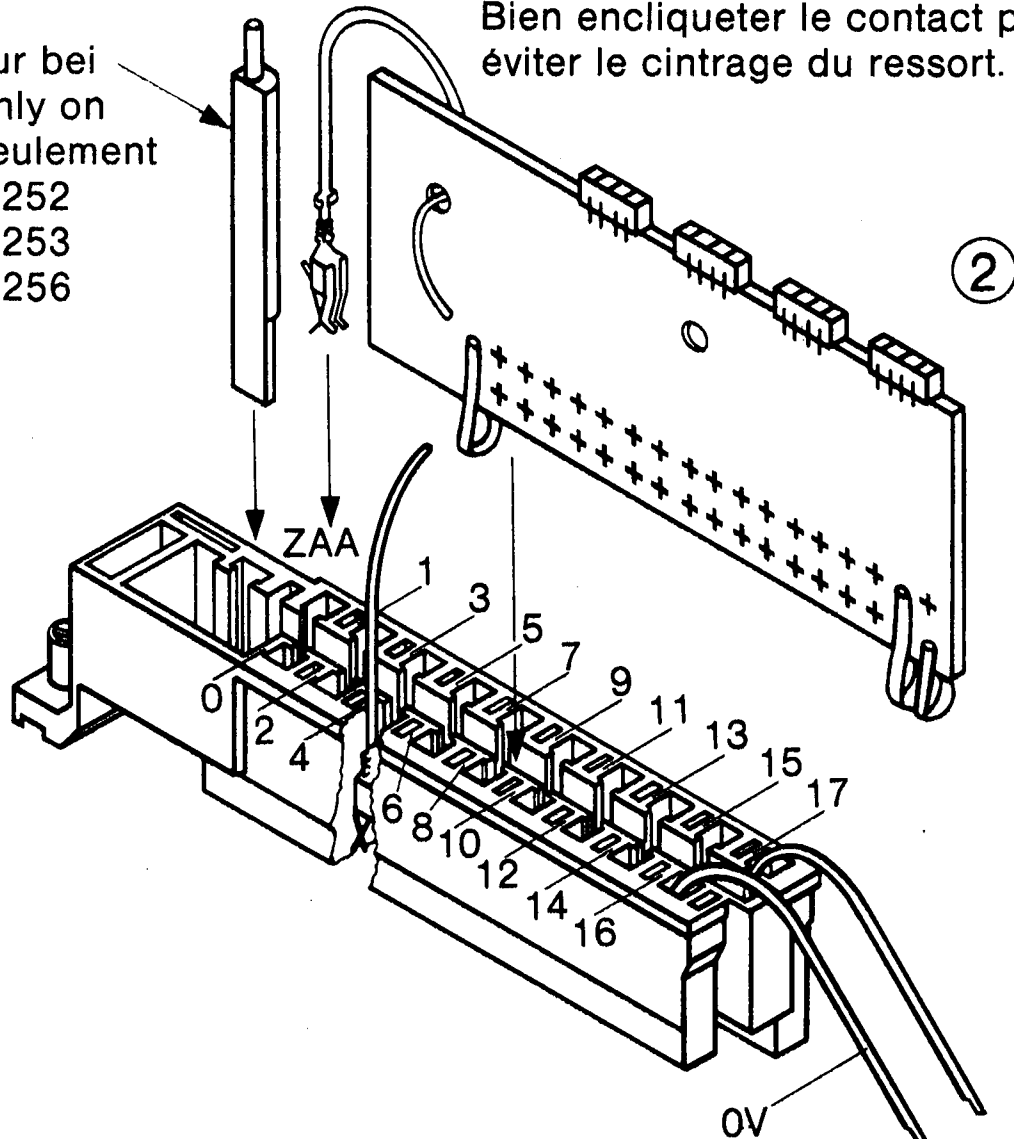

Nicht bei S 253
 Not on S 253
 Sauf pour S 253

Nur bei Einzelleiter
 Only with single wires
 Pour câbles unifilaires
 seulement

Crimpzange
Crimping pliers
Pince à sertir

Firma AMP
 AMP Ltd.
 Société AMP
 82 5590-0

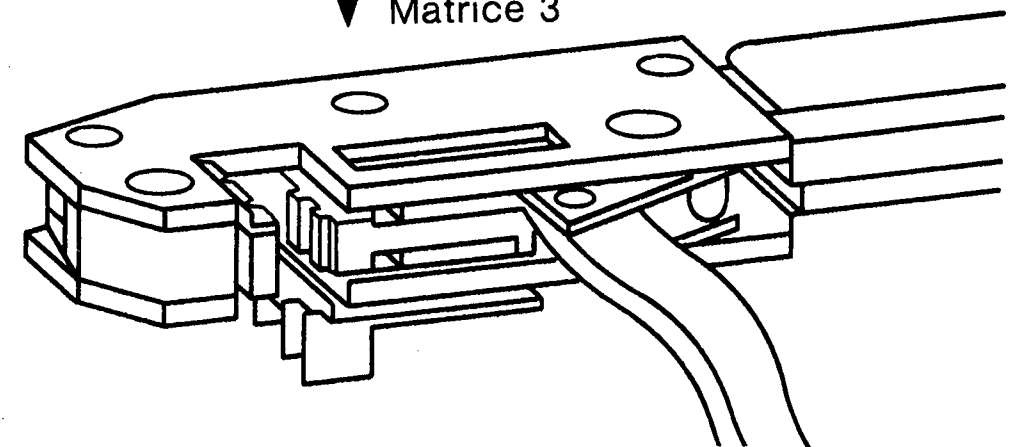
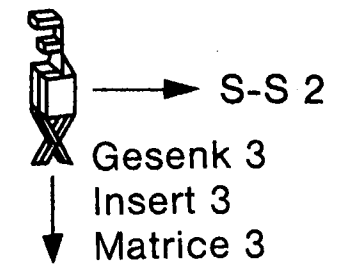

4

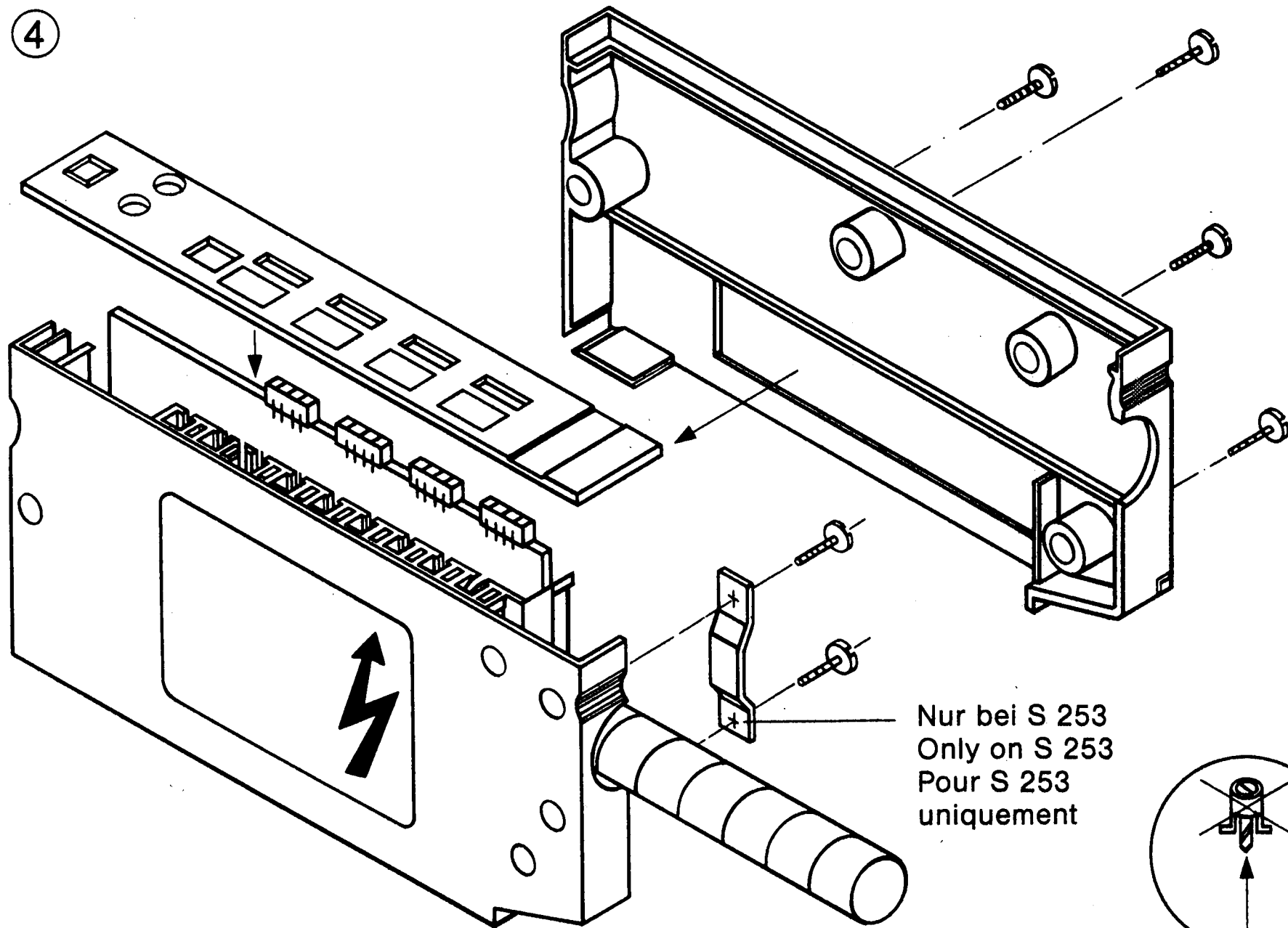

5

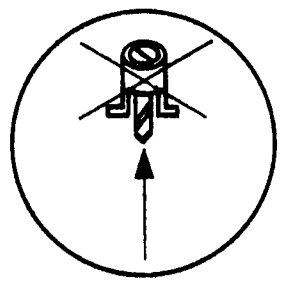
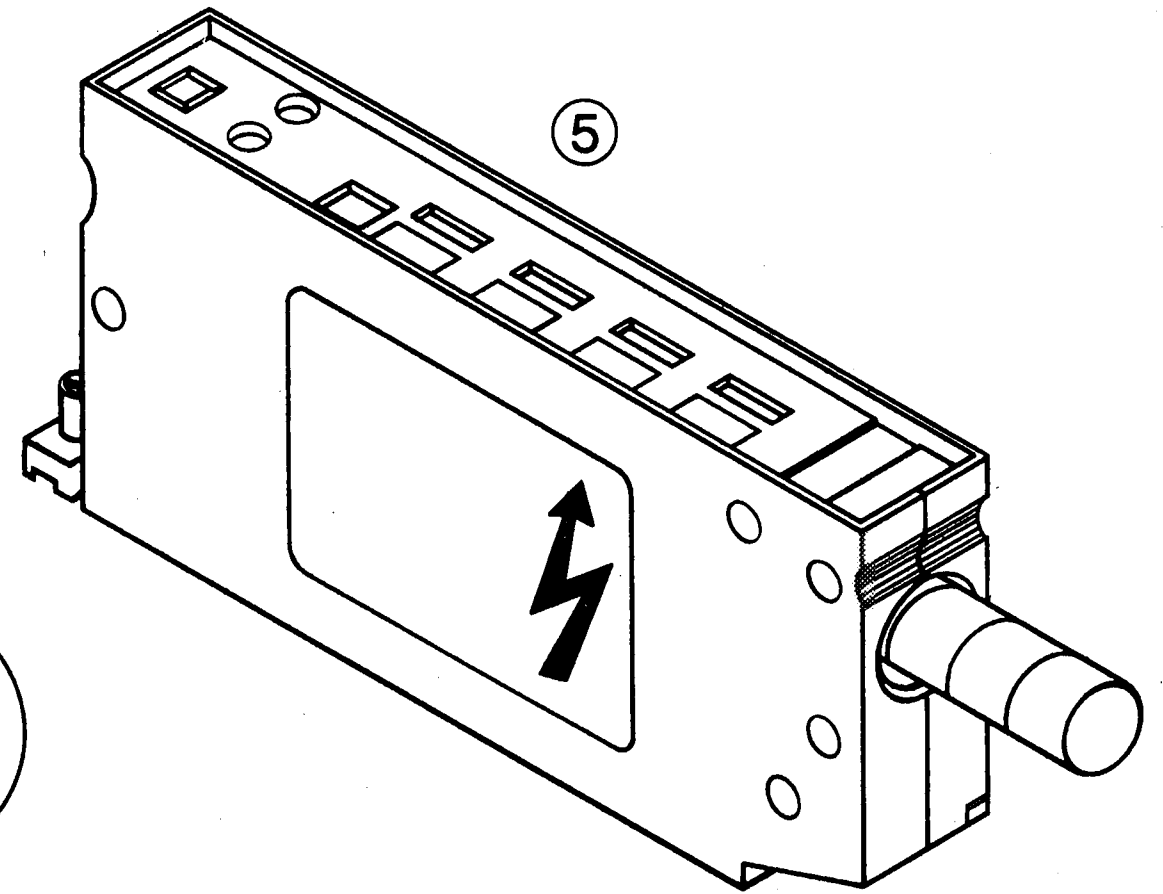

**Herausnehmen von
Leitungen aus der
Kontaktkammer
Withdrawing wires
from contact slot
Extraction des câbles
de l'alvéole de contact**

H = Ausziehwerkzeug
Firma Harting: 0999 000 0087
H = Extractor
Harting Co. 0999 000 0087
H = Extracteur
Société Harting: 0999 000 0087

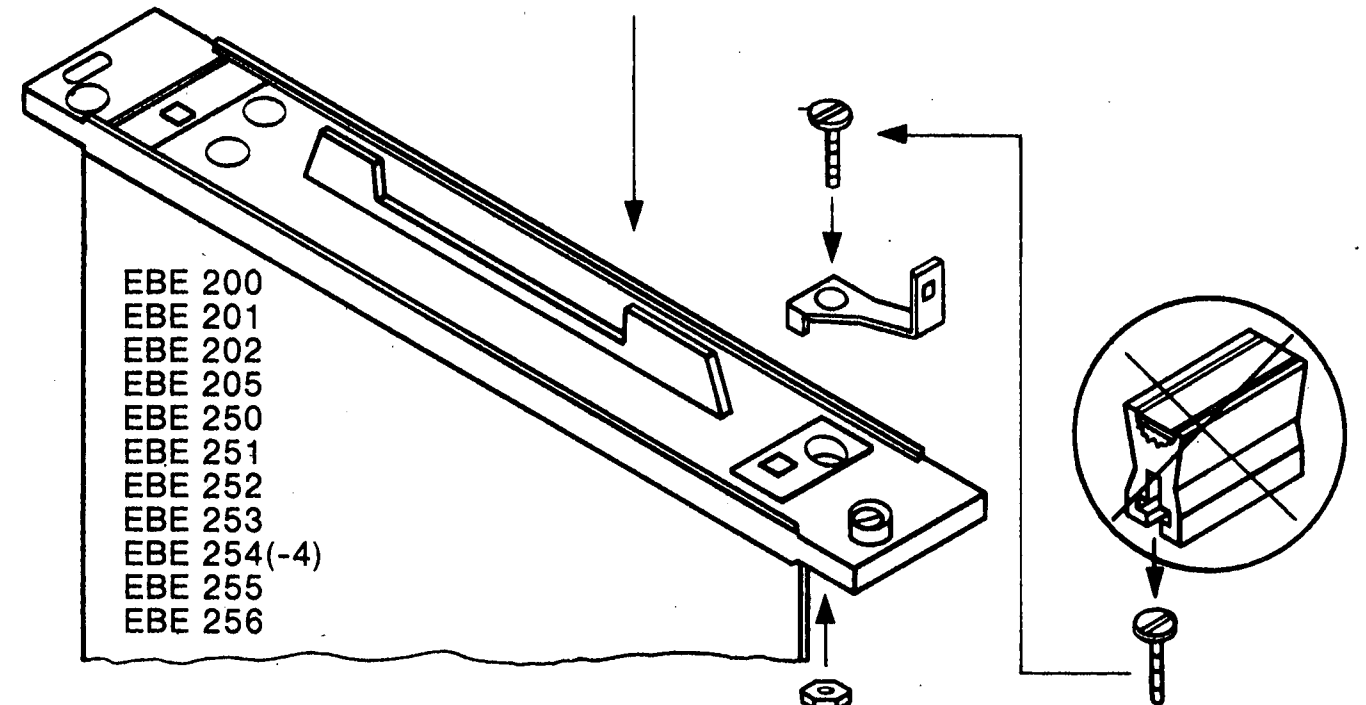
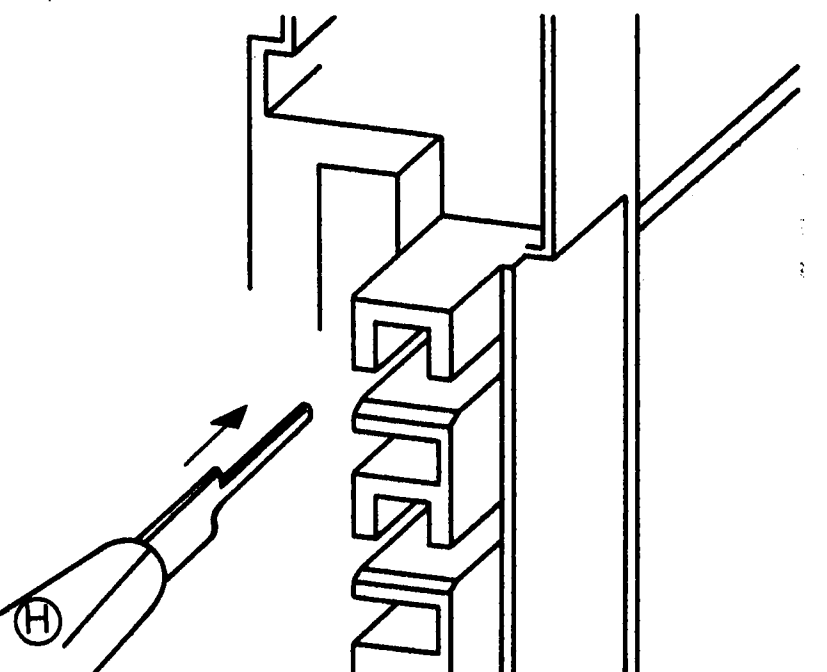

- EBE 200
- EBE 201
- EBE 202
- EBE 205
- EBE 250
- EBE 251
- EBE 252
- EBE 253
- EBE 254(-4)
- EBE 255
- EBE 256

Bezeichnungsmöglichkeiten an den Frontsteckern S 201, S 202, S 205, S 252, S 253, S 254(-4), S 265

Labelling facilities on front plugs S 201, S 202, S 205, S 252, S 253, S 254(-4), S 265

Repérages possibles des connecteurs S 201, S 202, S 205, S 252, S 253, S 254(-4), S 265

Kontaktkammer
Contact slot
Alvéoles de contact

Frontplatte
Front Plate
Plastron

KG 1

Schildträger (HPL)
Label holder (see Main Catalogue)
Support d'étiquettes (Cat. gén.)

Bezeichnungstreifen aufkleben, z. B. Stick on marking strip, e. g. Coller la bande de repérage (exemple)

00 02 04 06 08 10 12 14 16
I/Q

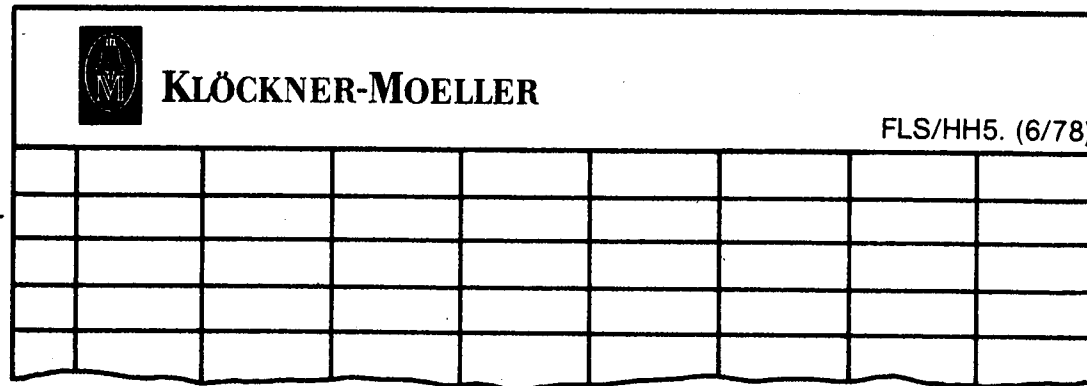
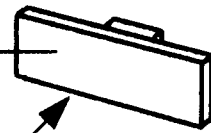
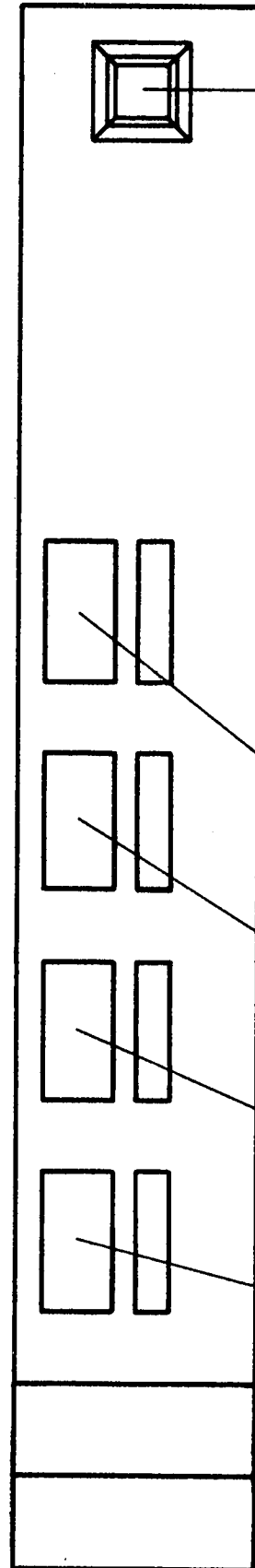
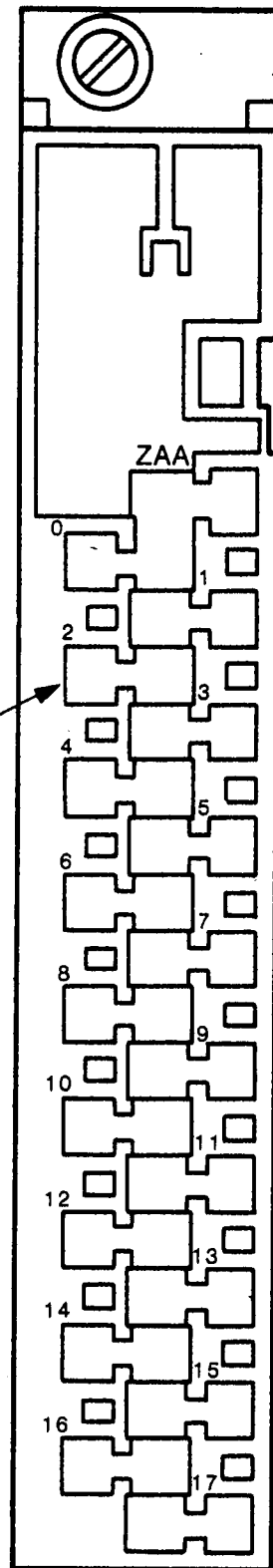

00	16	32	48	64	80	96
01	17	33	49	65	81	97
02	18	34	50	66	82	98
03	19	35	51	67	83	99
04	20	36	52	68	84	100
05	21	37	53	69	85	101
06	22	38	54	70	86	102
07	23	39	55	71	87	103
08	24	40	56	72	88	104
09	25	41	57	73	89	105
10	26	42	58	74	90	106
11	27	43	59	75	91	107
12	28	44	60	76	92	108
13	29	45	61	77	93	109
14	30	46	62	78	94	110
15	31	47	63	79	95	111

Bezeichnungsschild: FLS/HH 5
(nicht beiliegend)
Label: FLS/HH 5
(not supplied)
Etiquettes-repères: FLS/HH 5
(non jointes)

Bezeichnungsschilder (0-111 beiliegend)
Labels (0-111 enclosed)
Etiquettes-repères (0 à 111 jointes)

Verlegen der ZAA-Schleife bei S 252, S 253, S 256 Fitting ZAA loop on S 252, S 253, S 256 Pose de la boucle ZAA sur S 252, S 253, S 256

Externe Verdrahtung der ZAA-Flachsteckanschlüsse am Frontstecker mit konfektionierter Leitung AWG 20...-bl (Liste 27)
External wiring of ZAA-loop Prefabricated wiring with fast-on connectors on front plug AWG 20...-bl (List 27E)
Câblage externe des bornes pour cosses faston de ZAA sur le connecteur avant avec des câbles préfabriqués AWG 20...-bl (Catalogue 27)

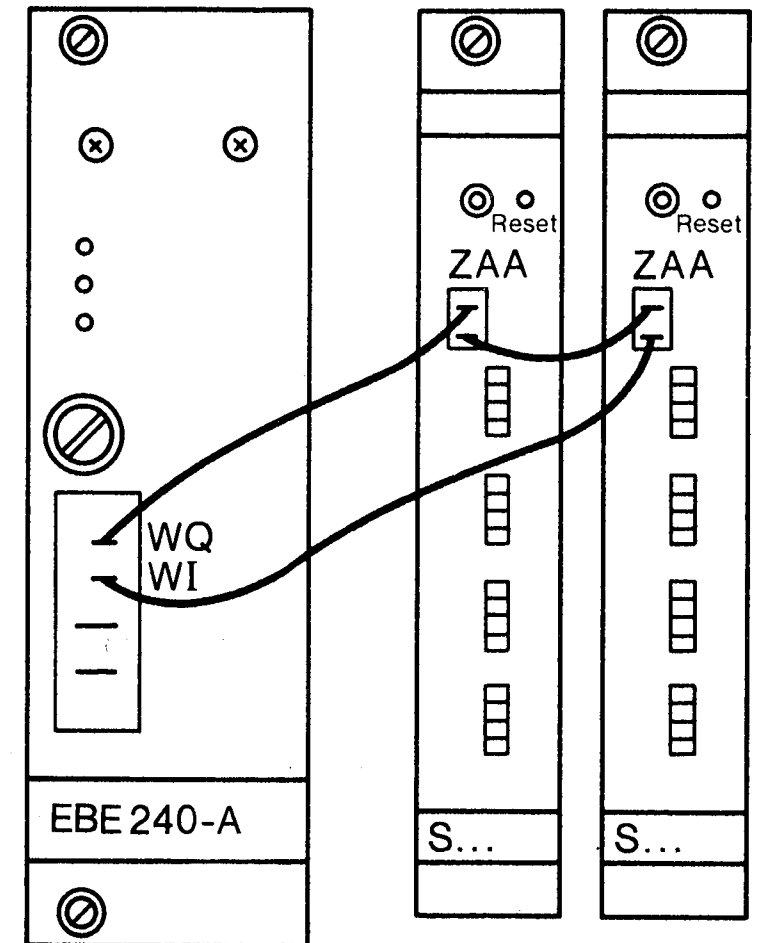

z. B. S 252

Input:
Output:

Bezeichnungsmöglichkeit am Frontstecker S 256
Labelling facility on front plug S 256
Repérage possible du connecteur S 256

Kontaktkammer
 Contact slot
 Alvéoles de contact

Bezeichnungstreifen
 aufkleben, z. B.
 Stick on marking
 strip, e. g.
 Coller la bande
 de repérage
 (exemple)

00
01
02
03
04
05
06
07
Q

Output:

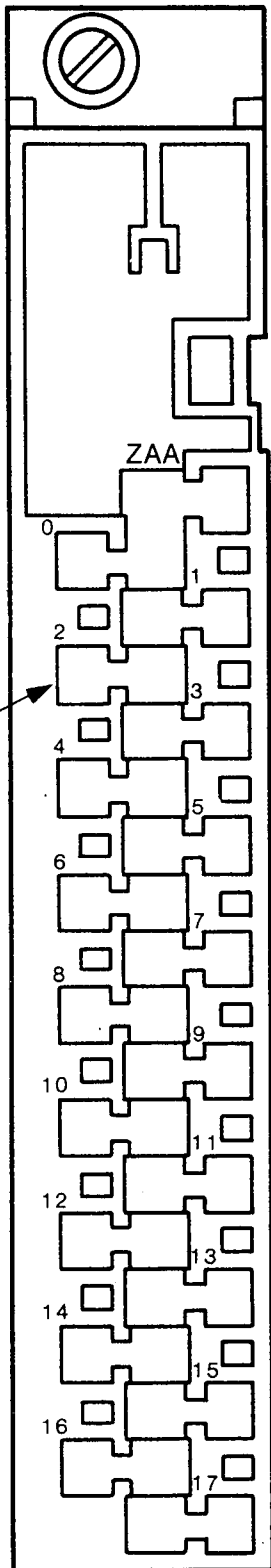

Frontplatte
 Front Plate
 Plastron

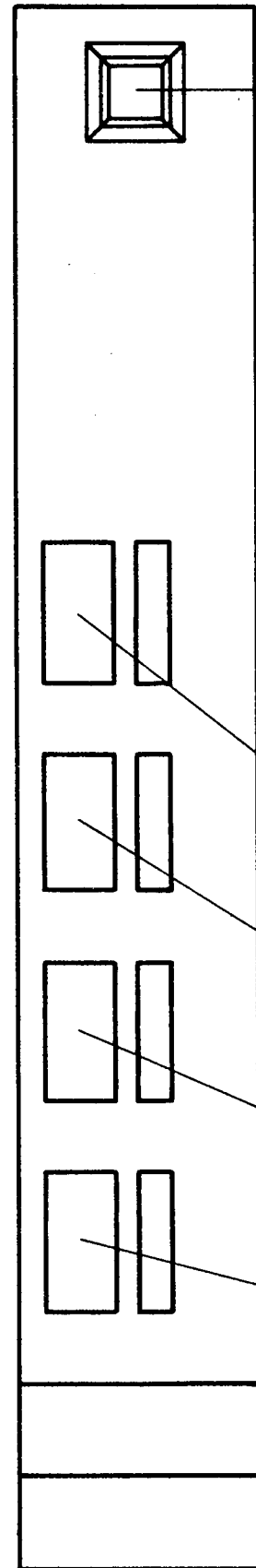

KG 1

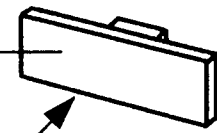

Schildträger (HPL)
 Label holder (see Main Catalogue)
 Support d'étiquettes (Cat. gén.)

Bezeichnungsschild: **FLS/HH 5**
 (nicht beiliegend)
 Label: **FLS/HH 5**
 (not supplied)
 Etiquettes-repères: **FLS/HH 5**
 (non jointes)

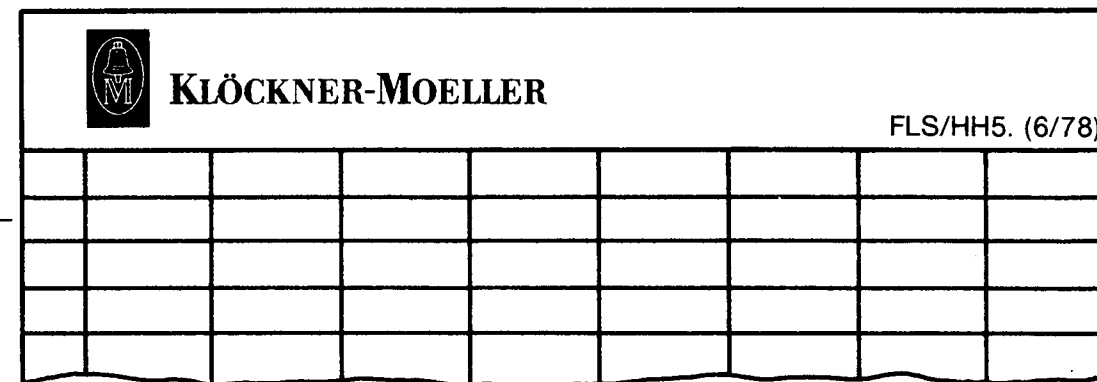

00	08	16	24	32	40	48	56
01	09	17	25	33	41	49	57
02	10	18	26	34	42	50	58
03	11	19	27	35	43	51	59
04	12	20	28	36	44	52	60
05	13	21	29	37	45	53	61
06	14	22	30	38	46	54	62
07	15	23	31	39	47	55	63

Bezeichnungsschilder (0-63 beiliegend)
 Labels (0-63 enclosed)
 Etiquettes-repères (0 à 63 jointes)

Verlegen der ZAA-Schleife bei S 256 und ZAA (ETS)
Fitting ZAA loop on S 256 and ZAA (ETS)
Pose de la boucle ZAA sur S 256 et ZAA (ETS)

Externe Verdrahtung der ZAA-Flachsteckanschlüsse am Frontstecker mit konfektionierter Leitung AWG 20...-bl (Liste 27)
 External wiring of ZAA-loop Prefabricated wiring with fast-on connectors on front plug AWG 20...-bl (List 27E)
 Câblage externe des bornes pour cosse faston de ZAA sur le connecteur avant avec des câbles préfabriqués AWG 20...-bl (Catalogue 27)

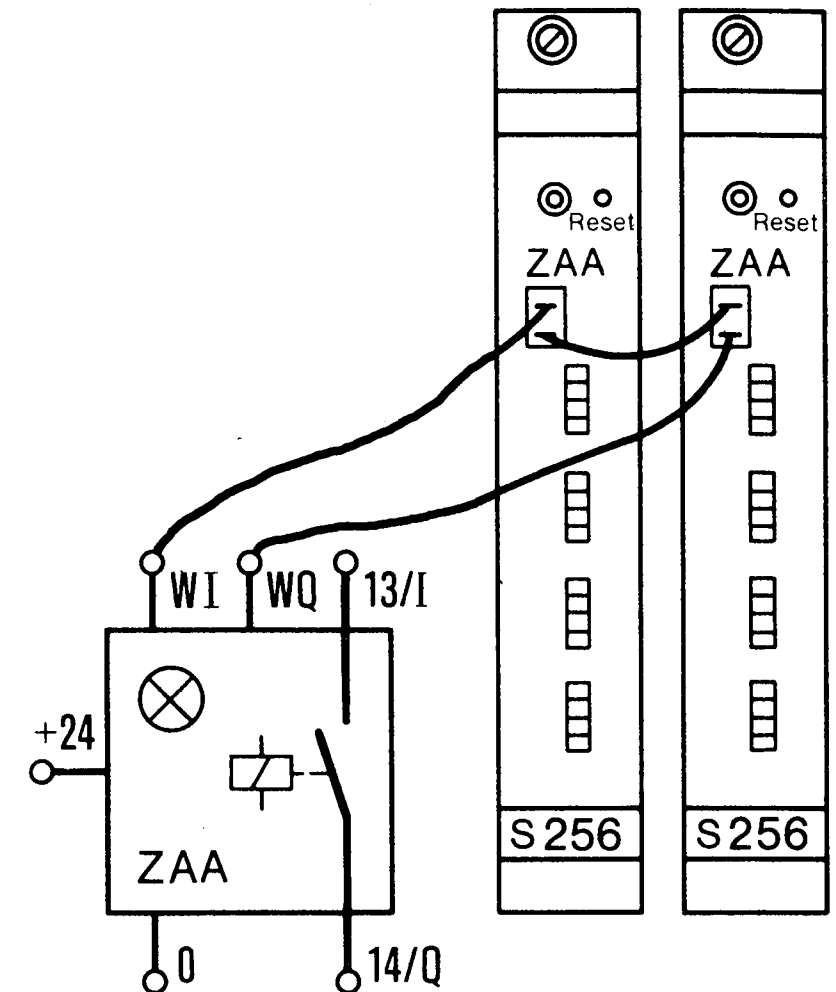

FLS/DM 50.
 Printed in the Federal Republic of Germany (3/86)