

MiCS-5524 with recommended supply circuit (top view)

R is a 82 Ω. This resistor is necessary to obtain the right temperature on the heater while using a single 5V power supply. The resulting voltage is typically $V_H = 2.4V$.

MiCS-5524 with measurement circuit (top view)

The voltage measured on the load resistor is directly linked to the resistance of the sensor respectively. RLOAD must be 820 Ω at the lowest in order not to damage the sensitive layer.

Parameter	Symbol	Typ	Min	Max	Unit
Heating power	P_H	76	71	81	mW
Heating voltage	V_H	2.4	-	-	V
Heating current	I_H	32	-	-	mA
Heating resistance at nominal power	R_H	74	66	82	Ω

Rating	Symbol	Value / Range	Unit
Maximum heater power dissipation	P_H	88	mW
Maximum sensitive layer power dissipation	P_s	8	mW
Voltage supplyHeating current	V_{supply}	4.9 – 5.1	V
Relative humidity range	RH	5 – 95	%RH
Ambient operating temperature	T_{amb}	-30 – 85	°C
Storage temperature range	T_{sto}	-40 – 120	°C
Storage humidity range	RH _{sto}	5 - 95	%RH

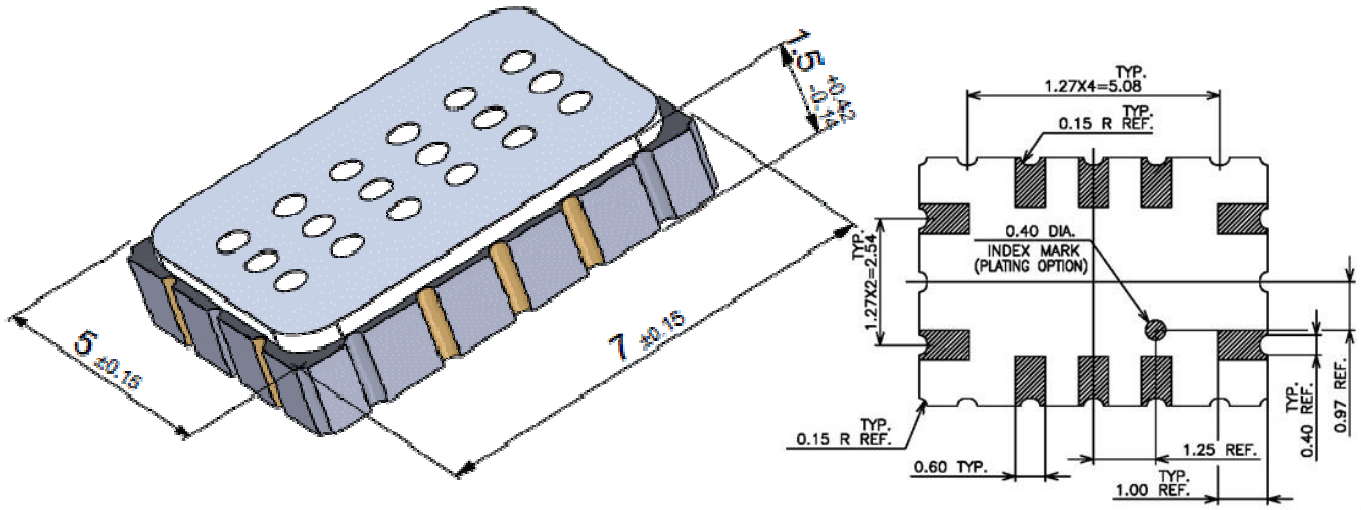

Package outline dimensions

The package is compatible with SMD assembly process.

Pin	Connection
A	
B	
C	Rh1
D	Rs1
E	
F	Rh2
G	Rs2
H	
J	
K	

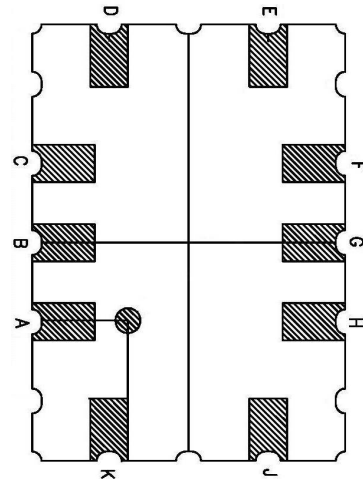

MiCS-5524 configuration (bottom view)

Sensor configuration

The silicon gas sensor structure consists of an accurately micro machined diaphragm with an embedded heating resistor and the sensing layer on top.

The internal connections are shown above.