

MX2 INVERTER

Born to drive machines



» Omron Quality with a capital 'Q'

» High programming functionality

» Built-in safety

Harmonised motor and machine control

The MX2 is specifically designed to drive machines. It has been developed to harmonise advanced motor and machine control. Thanks to its advanced design and algorithms the MX2 provides smooth control down to zero speed, plus precise operation for fast cyclic operations and torque control capability in open loop. The MX2 also gives you comprehensive functionality for machine control such as positioning, speed synchronisation and logic programming. The MX2 is fully integrated within the Omron smart automation platform. The MX2 is the child of a true leader in machine automation.

MOTOR CONTROL

200% starting torque

- Near stand-still operation (0.5 Hz)
- Smooth control of high inertia loads
- Control of fast cyclic loads

Torque control in open loop

- Ideal for low to medium torque applications
- Can replace a flux vector or servo drive in suitable systems

Special motors

- Permanent magnet motors
- High speed motors up to 1000 Hz

One parameter auto-tuning

- Just by entering the kW rating of the motor the MX2 gives you smooth and safe operation





MACHINE CONTROL

Safety inside

- Conforms to safety norm ISO-13849 CAT3 performance level PL d
- 2 Safety inputs
- External device monitoring (EDM)

Logic programming

- Flow chart programming
- Text editor
- Intuitive - up to 5 tasks in parallel

Positioning

- Up to 8 pre-set positions with "Homing"
- Speed synchronisation

Integrated in the Omron Smart Automation

- CX-Drive programming tool connected via integrated USB port on MX2.
- Modbus RS485 built-in
- Option units for EtherCAT, Profibus, DeviceNet, ML-II and more...

100% Control...

High starting torque and torque control capability in open loop mode give you full control of your machine dynamics and performance. Options for all of the major fieldbus systems and a 24 VDC external supply keeps you in full control of your machine operation.



Torque master

The MX2 delivers 200% starting torque near stand-still (0.5 Hz) and can operate in torque control in open loop mode. This allows the MX2 to be used in applications where closed loop AC vector drives were previously used.

Easy network integration

Built-in RS485 Modbus communications and standard industrial networks, such as EtherCAT (compliant with CoE - CiA402 Drive profile -), MECHATROLINK-II, DeviceNet, Profibus or CompoNet as options.

External 24 VDC for continuous operation

With no additional hardware, a 24 VDC connection to the MX2 ensures the CPU is always in control, even if the main input is removed. This feature is vital in providing a controlled stop in emergency situations and in keeping the network communications operating.

...0% risk!

Safety is embedded in the MX2, according to ISO 13849-1, Cat 3, with two safety inputs and an External Device Monitoring (EDM) output.

No external contactors on the motor side are required, meaning simpler wiring for the user.



Safety embedded; ISO 13849-1, cat 3

Dual contactors at the output of the inverter are no longer required. Direct connection to a safety controller ensures compliance to ISO 13849-1, cat 3.



EDM monitoring output

An External Device Monitoring (EDM) output confirms the safety status of the inverter, saving you the cost and wiring of external devices to carry out the same function.



Direct integration into the safety circuit

MX2 inverters can fit easily into the safety circuit. The safety inputs can be linked from one inverter to another without additional safety relays.

Position and run!

The MX2 is a drive and position controller in one, ideal for modular machines where moderate positional accuracy is required. Speed synchronisation is also possible, with no additional programming required.



Speed synchronisation

With no external hardware required, and via standard parameter settings, speed synchronisation can be achieved. The MX2 will act as a speed follower to an external pulse generator/ encoder signal up to 32 KHz.



Positioning functionality

Specially developed application functionality enables the MX2 to solve simple positioning tasks without the need for an external controller. Up to 8 positions, plus home, can be selected by the user, and furthermore, the MX2 can be switched between speed and position mode.

Program and play!

The MX2 gives you the power to create smart solutions using PLC functionality, as standard. Via an intuitive flow chart programming tool, you can create programs with up to 1000 lines of code and with 5 tasks running in parallel.



Free to program

- Intuitive and user friendly flow chart programming
- Integrated in CX-Drive
- Up to 1000 lines in a program
- 5 tasks can run in parallel



MX2

Born to drive machines

- Current vector control
- High starting torque: 200% at 0.5 Hz
- Double rating VT 120%/1 min and CT 150%/1 min
- IM & PM motor control
- Torque control in open loop vector
- Positioning functionality
- Built-in application functionality (i.e. Brake control)
- Built-in logic programming
- Safety embedded compliant with ISO13849-1 (double input circuit and external device monitor EDM)
- USB port for PC programming
- 24 VDC backup supply for control board
- Fieldbus communications: Modbus, DeviceNet, Profibus, CompoNet, EtherCAT, ML-II and EtherNet/IP
- PC configuration tool: CX-Drive
- RoHS, CE, cULus

Ratings

- 200 V Class single-phase 0.1 to 2.2 kW
- 200 V Class three-phase 0.1 to 15.0 kW
- 400 V Class three-phase 0.4 to 15.0 kW



System configuration



Specifications

Type designation



200 V class

| Single-phase: 3G3MX2-□ | | B001 | B002 | B004 | B007 ¹ | B015 | B022 | - | - | - | - | - | |
|--------------------------------|-----------------------------------|---|---|------|-------------------|---------------------------|------|--------------------------------|------|------------|------|------|------|
| Three-phase: 3G3MX2-□ | | 2001 | 2002 | 2004 | 2007 | 2015 | 2022 | 2037 | 2055 | 2075 | 2110 | 2150 | |
| Motor kW ² | For VT setting | 0.2 | 0.4 | 0.55 | 1.1 | 2.2 | 3.0 | 5.5 | 7.5 | 11 | 15 | 18.5 | |
| | For CT setting | 0.1 | 0.2 | 0.4 | 0.75 | 1.5 | 2.2 | 3.7 | 5.5 | 7.5 | 11 | 15 | |
| Output characteristics | Inverter capacity kVA | 200 VT | 0.4 | 0.6 | 1.2 | 2.0 | 3.3 | 4.1 | 6.7 | 10.3 | 13.8 | 19.3 | 23.9 |
| | | 200 CT | 0.2 | 0.5 | 1.0 | 1.7 | 2.7 | 3.8 | 6.0 | 8.6 | 11.4 | 16.2 | 20.7 |
| | | 240 VT | 0.4 | 0.7 | 1.4 | 2.4 | 3.9 | 4.9 | 8.1 | 12.4 | 16.6 | 23.2 | 28.6 |
| | | 240 CT | 0.3 | 0.6 | 1.2 | 2.0 | 3.3 | 4.5 | 7.2 | 10.3 | 13.7 | 19.5 | 24.9 |
| Rated output current (A) at VT | | 1.2 | 1.9 | 3.5 | 6.0 | 9.6 | 12.0 | 19.6 | 30.0 | 40.0 | 56.0 | 69.0 | |
| Rated output current (A) at CT | | 1.0 | 1.6 | 3.0 | 5.0 | 8.0 | 11.0 | 17.5 | 25.0 | 33.0 | 47.0 | 60.0 | |
| Max. output voltage | | Proportional to input voltage: 0..240 V | | | | | | | | | | | |
| Max. output frequency | | 400 Hz | | | | | | | | | | | |
| Power supply | Rated input voltage and frequency | | Single-phase 200..240 V 50/60 Hz 3-phase 200..240 V 50/60 Hz | | | | | | | | | | |
| | Allowable voltage fluctuation | | -15%..+10% | | | | | | | | | | |
| | Allowable frequency fluctuation | | 5% | | | | | | | | | | |
| Braking torque | | At short-time deceleration At capacitor feedback | | | | 100%: <50Hz 50%: <60Hz | | 70%: <50Hz 50%: <60Hz | | Approx 20% | | - | |
| Cooling method | | Self cooling ³ | | | | Forced-air-cooling | | | | | | | |

1. Three phase model use forced-air-cooling but single phase model is self cooling.
2. Based on a standard 3-Phase standard motor.
3. Forced air cooling for IP54 models.

400 V class

| Three-phase: 3G3MX2-□ | | 4004 | 4007 | 4015 | 4022 | 4030 | 4040 | 4055 | 4075 | 4110 | 4150 | | |
|--------------------------------|-----------------------------------|---|-----------------------------|------|------|---------------------------|------|--------------------------------|------|------|------|------|--|
| Motor kW ¹ | For VT setting | 0.75 | 1.5 | 2.2 | 3.0 | 4.0 | 5.5 | 7.5 | 11 | 15 | 18.5 | | |
| | For CT setting | 0.4 | 0.75 | 1.5 | 2.2 | 3.0 | 4.0 | 5.5 | 7.5 | 11 | 15 | | |
| Output characteristics | Inverter capacity kVA | 380 VT | 1.3 | 2.6 | 3.5 | 4.5 | 5.7 | 7.3 | 11.5 | 15.1 | 20.4 | 25.0 | |
| | | 380 CT | 1.1 | 2.2 | 3.1 | 3.6 | 4.7 | 6.0 | 9.7 | 11.8 | 15.7 | 20.4 | |
| | | 480 VT | 1.7 | 3.4 | 4.4 | 5.7 | 7.3 | 9.2 | 14.5 | 19.1 | 25.7 | 31.5 | |
| | | 480 CT | 1.4 | 2.8 | 3.9 | 4.5 | 5.9 | 7.6 | 12.3 | 14.9 | 19.9 | 25.7 | |
| Rated output current (A) at VT | | 2.1 | 4.1 | 5.4 | 6.9 | 8.8 | 11.1 | 17.5 | 23.0 | 31.0 | 38.0 | | |
| Rated output current (A) at CT | | 1.8 | 3.4 | 4.8 | 5.5 | 7.2 | 9.2 | 14.8 | 18.0 | 24.0 | 31.0 | | |
| Max. output voltage | | Proportional to input voltage: 0..480 V | | | | | | | | | | | |
| Max. output frequency | | 400 Hz | | | | | | | | | | | |
| Power supply | Rated input voltage and frequency | | 3-phase 380..480 V 50/60 Hz | | | | | | | | | | |
| | Allowable voltage fluctuation | | -15%..+10% | | | | | | | | | | |
| | Allowable frequency fluctuation | | 5% | | | | | | | | | | |
| Braking torque | | At short-time deceleration At capacitor feedback | | | | 100%: <50Hz 50%: <60Hz | | 70%: <50Hz 50%: <60Hz | | - | | - | |
| Cooling method | | Self cooling ² | | | | Forced-air-cooling | | | | | | | |

1. Based on a standard 3-Phase standard motor.
2. Forced air cooling for IP54 models.

Specifications

Common specifications

| Model number 3G3MX2 | | Specifications | |
|-------------------------|--|---|---|
| Control functions | Control methods | Phase-to-phase sinusoidal pulse with modulation PWM (Sensorless vector control, V/F) | |
| | Output frequency range | 0.10..400.00 Hz | |
| | Frequency precision | Digital set value: ±0.01% of the max. frequency | |
| | | Analogue set value: ±0.2% of the max. frequency (25 ±10°C) | |
| | Resolution of frequency set value | Digital set value: 0.01 Hz | |
| | | Analogue set value: 1/1000 of maximum frequency | |
| | Resolution of output frequency | 0.01Hz | |
| | Starting torque | 200% / 0.5 Hz | |
| | Overload capability | Dual rating: Heavy duty (CT): 150% for 1 minute Normal Duty (VT): 120% for 1 minute | |
| Frequency set value | 0 to 10 VDC (10 KΩ), 4 to 20 mA (100 Ω), RS485 Modbus, Network options | | |
| V/f Characteristics | Constant/ reduced torque, free V/f | | |
| Functionality | Inputs signals | FW (forward run command), RV (reverse run command), CF1~CF4 (multi-stage speed setting), JG (jog command), DB (external braking), SET (set second motor), 2CH (2-stage accel./decel. command), FRS (free run stop command), EXT (external trip), USP (startup function), CS (commercial power switchover), SFT (soft lock), AT (analog input selection), RS (reset), PTC (thermistor thermal protection), STA (start), STP (stop), F/R (forward/reverse), PID (PID disable), PIDC (PID reset), UP (remote control up function), DWN (remote control down function), UDC (remote control data clear), OPE (operator control), SF1~SF7 (multi-stage speed setting; bit operation), OLR (overload restriction), TL (torque limit enable), TRQ1 (torque limit changeover1), TRQ2 (torque limit changeover2), BOK (Braking confirmation), LAC (LAD cancellation), PCLR (position deviation clear), ADD (add frequency enable), F-TM (force terminal mode), ATR (permission of torque command input), KHC (Cumulative power clear), MI1~MI7 (general purpose inputs for Drive Programming), AHD (analog command hold), CP1~CP3 (multistage-position switches), ORL (limit signal of zero-return), ORC (trigger signal of zero-return), SPD (speed/position changeover), GS1~GS2 (STO inputs, safety related signals), 485 (Starting communication signal), PRG (executing Drive Programming), HLD (retain output frequency), ROK (permission of run command), EB (rotation direction detection of B-phase), DISP (display limitation), OP (option control signal), NO (no function), PSET (preset position) | |
| | Output signals | RUN (run signal), FA1~FA5 (frequency arrival signal), OL,OL2 (overload advance notice signal), OD (PID deviation error signal), AL (alarm signal), OTQ (over/under torque threshold), UV (under-voltage), TRQ (torque limit signal), RNT (run time expired), ONT (power ON time expired), THM (thermal warning), BRK (brake release), BER (brake error), ZS (0Hz detection), DSE (speed deviation excessive), POK (positioning completion), ODc (analog voltage input disconnection), OIdc (analog current input disconnection), FBV (PID second stage output), NDc (network disconnect detection), LOG1~LOG3 (Logic output signals), WAC (capacitor life warning), WAF (cooling fan warning), FR (starting contact), OHF (heat sink overheat warning), LOC (Low load), MO1~MO3 (general outputs for Drive Programming), IRDY (inverter ready), FWR (forward operation), RVR (reverse operation), MJA (major failure), WCO (window comparator O), WCOI (window comparator OI), FREF (frequency command source), REF (run command source), SETM (second motor in operation), EDM (STO (safe torque off) performance monitor), OP (option control signal), NO (no function) | |
| | Standard functions | Free-V/f, manual/automatic torque boost, output voltage gain adjustment, AVR function, reduced voltage start, motor data selection, auto-tuning, motor stabilization control, reverse running protection, simple position control, simple torque control, torque limiting, automatic carrier frequency reduction, energy saving operation, PID function, non-stop operation at instantaneous power failure, brake control, DC injection braking, dynamic braking (BRD), frequency upper and lower limiters, jump frequencies, curve accel and decel (S, U, inversed U,EL-S), 16-stage speed profile, fine adjustment of start frequency, accel and decel stop, process jogging, frequency calculation, frequency addition, 2-stage accel/decel, stop mode selection, start/end freq., analog input filter, window comparators, input terminal response time, output signal delay/hold function, rotation direction restriction, stop key selection, software lock, safe stop function, scaling function, display restriction, password function, user parameter, initialization, initial display selection, cooling fan control, warning, trip retry, frequency pull-in restart, frequency matching, overload restriction, over current restriction, DC bus voltage AVR | |
| | Analogue inputs | 2 analogue inputs 0 to 10 V (10 KΩ), 4 to 20 mA (100 Ω) | |
| | Pulse train input terminal | 0 to 24 V, up to 32 kHz | |
| | Accel/Decel times | 0.01 to 3600.0 s (line/curve selection), 2nd accel/decel setting available | |
| | Display | Status indicator LED's Run, Program, Alarm, Power, Hz, Amps Digital operator: Available to monitor 32 items: frequency reference, output current, output frequency... | |
| | Protection functions | Motor overload protection | Electronic Thermal overload relay and PTC thermistor input |
| | | Instantaneous overcurrent | 200% of rated current |
| | | Overload | Dual rating: Heavy duty (CT): 150% for 1 minute Normal Duty (VT): 120% for 1 minute |
| Overvoltage | | 800 V for 400 V type and 400 V for 200 V type | |
| Undervoltage | | 345 V for 400 V type and 172.5 V for 200 V type | |
| Momentary power loss | | Following items are selectable: Alarm, decelerates to stop, decelerates to stop with DC bus controlled, restart | |
| Cooling fin overheat | | Temperature monitor and error detection | |
| Stall prevention level | | Stall prevention during acceleration/deceleration and constant speed | |
| Ground fault | | Detection at power-on | |
| Power charge indication | On when power is supplied to the control part | | |
| Ambient conditions | Degree of protection | IP20, Varnish coating on PCB & IP54 (For 3G3MX2-D□ type) | |
| | Ambient humidity | 90% RH or less (without condensation) | |
| | Storage temperature | -20°C..+65°C (short-term temperature during transportation) | |
| | Ambient temperature ¹ | -10°C to 50°C (Both the carrier frequency and output current need to be reduced over 40°C) | |
| | Installation | Indoor (no corrosive gas, dust, etc.) | |
| | Installation height | Max. 1000 m | |
| Vibration | 5.9 m/s ² (0.6G), 10 to 55 Hz | | |

1. Some types of 3G3MX2-D requires special derating depending on installation conditions and carrier frequency selected. Check the manual for details.

Dimensions

Standard models (IP20)



| Voltage class | Inverter model 3G3MX2-A□ | Figure | Dimensions in mm | | | | | | | | | | |
|-----------------------|-----------------------------|--------|------------------|-----|-----|-----|-----|-------|------|-----|-----|-------------|-----|
| | | | W | W1 | H | H1 | t | D | D1 | D2 | d | Weight (kg) | |
| Single-phase 200 V | B001-E | 1 | 68 | 56 | 128 | 118 | - | 109 | 13.5 | - | - | 1.0 | |
| | B002-E | | | | | | | 122.5 | 27 | | | | 1.0 |
| | B004-E | | | | | | | 122.5 | 27 | | | | 1.1 |
| | B007-E | 2 | 108 | 96 | 128 | 118 | - | 170.5 | 55 | 4.4 | 4.5 | 1.4 | |
| | B015-E | | | | | | | | | | | 1.8 | |
| B022-E | 1.8 | | | | | | | | | | | | |
| Three-phase 200 V | 2001-E | 1 | 68 | 56 | 128 | 118 | - | 109 | 13.5 | - | - | 1.0 | |
| | 2002-E | | | | | | | 122.5 | 27 | | | | 1.0 |
| | 2004-E | | | | | | | 122.5 | 27 | | | | 1.1 |
| | 2007-E | 2 | 108 | 96 | 128 | 118 | - | 170.5 | 55 | 4.4 | 4.5 | 1.2 | |
| | 2015-E | | | | | | | | | | | 1.6 | |
| | 2022-E | 1.8 | | | | | | | | | | | |
| | 2037-E | 3 | 140 | 128 | 128 | 118 | 5 | 170.5 | 55 | 4.4 | 4.5 | 2.0 | |
| | 2055-E | | | | | | 6 | 155 | 73.3 | 6 | | 6 | 3.0 |
| | 2075-E | | | | | | 6 | 155 | 73.3 | 6 | | 6 | 3.4 |
| | 2110-E | | | | | | 7 | 175 | 97 | 5 | | 7 | 5.1 |
| 2150-E | 7 | 175 | 84 | 5 | 7 | 7.4 | | | | | | | |
| Three-phase 400 V | 4004-E | 2 | 108 | 96 | 128 | 118 | - | 143.5 | 28 | - | - | 1.5 | |
| | 4007-E | | | | | | | 170.5 | 55 | | | 1.6 | |
| | 4015-E | | | | | | | 170.5 | 55 | | | 1.8 | |
| | 4022-E | 3 | 140 | 128 | 128 | 118 | 5 | 170.5 | 55 | 4.4 | 4.5 | 2.1 | |
| | 4030-E | | | | | | 6 | 155 | 73.3 | 6 | 6 | 3.5 | |
| | 4040-E | | | | | | 6 | 155 | 73.3 | 6 | 6 | 3.5 | |
| | 4055-E | | | | | | 7 | 175 | 97 | 5 | 7 | 4.7 | |
| | 4075-E | 7 | 175 | 97 | 5 | 7 | 4.7 | | | | | | |
| | 4110-E | 7 | 175 | 97 | 5 | 7 | 4.7 | | | | | | |
| 4150-E | 7 | 175 | 97 | 5 | 7 | 5.2 | | | | | | | |

Option board



Note: Option boards could be fitted inside the IP54 model.

Finless models



| Voltage class | Inverter model 3G3MX2-A□ | Figure | Dimensions in mm | | | | | | Weight (kg) |
|-----------------------|-----------------------------|--------|------------------|-----|-----|-----|-----|-----|-------------|
| | | | W | W1 | H | H1 | D | D1 | |
| Single-phase 200 V | B001-P-E | 1 | 68 | 56 | 128 | 118 | 103 | 7.5 | 1.1 |
| | B002-P-E | | | | | | | | |
| | B004-P-E | | | | | | | | |
| | B007-P-E | 2 | | | | | | | |
| | B015-P-E | | | | | | | | |
| B022-P-E | | | | | | | | | |
| Three-phase 200 V | 2001-P-E | 1 | 108 | 96 | 128 | 118 | 123 | 7.5 | 1.8 |
| | 2002-P-E | | | | | | | | |
| | 2004-P-E | | | | | | | | |
| | 2007-P-E | 2 | | | | | | | |
| | 2015-P-E | | | | | | | | |
| | 2022-P-E | | | | | | | | |
| 2037-P-E | 3 | 140 | 128 | 128 | 118 | 123 | 7.5 | 2.1 | |
| Three-phase 400 V | 4004-P-E | 2 | 108 | 96 | 128 | 118 | 123 | 7.5 | 1.8 |
| | 4007-P-E | | | | | | | | |
| | 4015-P-E | | | | | | | | |
| | 4022-P-E | | | | | | | | |
| | 4030-P-E | | | | | | | | |
| | 4040-P-E | 3 | | | | | | | |

IP54 models



| Figure 1 | Figure 2 | Figure 3 | Figure 4 |
|----------------|-----------------|-----------------|-----------------|
| 3G3MX2-DB001-E | 3G3MX2-DB001-EC | 3G3MX2-D2055-EC | 3G3MX2-D2110-EC |
| 3G3MX2-DB002-E | 3G3MX2-DB002-EC | 3G3MX2-D2075-EC | 3G3MX2-D2150-EC |
| 3G3MX2-DB004-E | 3G3MX2-DB004-EC | 3G3MX2-D4055-EC | 3G3MX2-D4110-EC |
| 3G3MX2-D2001-E | 3G3MX2-DB007-EC | 3G3MX2-D4075-EC | 3G3MX2-D4150-EC |
| 3G3MX2-D2002-E | 3G3MX2-DB015-EC | | |
| 3G3MX2-D2004-E | 3G3MX2-DB022-EC | | |
| 3G3MX2-D2007-E | 3G3MX2-D2001-EC | | |
| | 3G3MX2-D2002-EC | | |
| | 3G3MX2-D2004-EC | | |
| | 3G3MX2-D2007-EC | | |
| | 3G3MX2-D2015-EC | | |
| | 3G3MX2-D2022-EC | | |
| | 3G3MX2-D2037-EC | | |
| | 3G3MX2-D4004-EC | | |
| | 3G3MX2-D4007-EC | | |
| | 3G3MX2-D4015-EC | | |
| | 3G3MX2-D4022-EC | | |
| | 3G3MX2-D4030-EC | | |
| | 3G3MX2-D4040-EC | | |

Rasmi footprint filters



| Rasmi model | | Dimensions | | | | | |
|-------------|----------------|------------|----|-----|-----|-----|----|
| | | W | H | L | X | Y | M |
| 1x200 V | AX-FIM1010-RE□ | 71 | 45 | 169 | 156 | 51 | M4 |
| | AX-FIM1014-RE□ | 111 | 50 | 169 | 156 | 91 | M4 |
| | AX-FIM1024-RE□ | 111 | 50 | 169 | 156 | 91 | M4 |
| 3x200 V | AX-FIM2010-RE□ | 82 | 50 | 194 | 181 | 62 | M4 |
| | AX-FIM2020-RE□ | 111 | 50 | 169 | 156 | 91 | M4 |
| | AX-FIM2030-RE□ | 144 | 50 | 174 | 161 | 120 | M4 |
| | AX-FIM2060-RE□ | 150 | 52 | 320 | 290 | 122 | M5 |
| | AX-FIM2080-RE□ | 188 | 62 | 362 | 330 | 160 | M5 |
| | AX-FIM2100-RE□ | 220 | 62 | 415 | 380 | 192 | M6 |
| 3x400 V | AX-FIM3005-RE□ | 114 | 46 | 169 | 156 | 96 | M4 |
| | AX-FIM3010-RE□ | 114 | 46 | 169 | 156 | 96 | M4 |
| | AX-FIM3014-RE□ | 144 | 50 | 174 | 161 | 120 | M4 |
| | AX-FIM3030-RE□ | 150 | 52 | 306 | 290 | 122 | M5 |
| | AX-FIM3050-RE□ | 182 | 62 | 357 | 330 | 160 | M5 |



Schaffner footprint filters

| Schaffner model | | Dimensions | | | | | | | |
|-----------------|----------------|------------|----|-----|-----|-----|-----|-----|----|
| | | W | H | L | X | Y | A | B | M |
| 1x200 V | AX-FIM1010-SE□ | 70 | 40 | 166 | 156 | 51 | 150 | 50 | M5 |
| | AX-FIM1014-SE□ | 110 | 45 | 166 | 156 | 91 | 150 | 80 | M5 |
| | AX-FIM1024-SE□ | 110 | 50 | 166 | 156 | 91 | 150 | 80 | M5 |
| 3x200 V | AX-FIM2010-SE□ | 80 | 40 | 191 | 181 | 62 | 150 | 50 | M5 |
| | AX-FIM2020-SE□ | 110 | 50 | 166 | 156 | 91 | 150 | 80 | M5 |
| | AX-FIM2030-SE□ | 142 | 50 | 171 | 161 | 120 | 150 | 112 | M5 |
| | AX-FIM2060-SE□ | 140 | 55 | 304 | 290 | 122 | 286 | 112 | M5 |
| | AX-FIM2080-SE□ | 180 | 55 | 344 | 330 | 160 | 323 | 140 | M5 |
| | AX-FIM2100-SE□ | 220 | 65 | 394 | 380 | 192 | 376 | 180 | M5 |
| 3x400 V | AX-FIM3005-SE□ | 110 | 50 | 166 | 156 | 91 | 150 | 80 | M5 |
| | AX-FIM3010-SE□ | 110 | 50 | 166 | 156 | 91 | 150 | 80 | M5 |
| | AX-FIM3014-SE□ | 142 | 50 | 171 | 161 | 120 | 150 | 112 | M5 |
| | AX-FIM3030-SE□ | 140 | 55 | 304 | 290 | 122 | 286 | 112 | M5 |
| | AX-FIM3050-SE□ | 180 | 55 | 344 | 330 | 160 | 323 | 140 | M5 |

Input AC Reactor

Single-phase

| Voltage | Reference | Dimensions | | | | | | | | Weight kg |
|---------|-------------------|------------|-----|-----|-----|----|---|-----|---|-----------|
| | | A | B | C | D | E | F | G | H | |
| 200 V | AX-RAI02000070-DE | 84 | 113 | 96 | 101 | 66 | 5 | 7.5 | 2 | 1.22 |
| | AX-RAI01700140-DE | 84 | 113 | 116 | 101 | 66 | 5 | 7.5 | 2 | 1.95 |
| | AX-RAI01200200-DE | 84 | 113 | 131 | 101 | 66 | 5 | 7.5 | 2 | 2.55 |
| | AX-RAI00630240-DE | 84 | 113 | 116 | 101 | 66 | 5 | 7.5 | 2 | 1.95 |



Three-phase

| Voltage | Reference | Dimensions | | | | | | Weight kg |
|---------|-------------------|------------|----|-----|-----|----|-----|-----------|
| | | A | B2 | C2 | D | E | F | |
| 200 V | AX-RAI02800080-DE | 120 | 70 | 120 | 80 | 52 | 5.5 | 1.78 |
| | AX-RAI00880200-DE | 120 | 80 | 120 | 80 | 62 | 5.5 | 2.35 |
| | AX-RAI00350335-DE | 180 | 85 | 190 | 140 | 55 | 6 | 5.5 |
| | AX-RAI00180670-DE | 180 | 85 | 190 | 140 | 55 | 6 | 5.5 |
| 400 V | AX-RAI07700050-DE | 120 | 70 | 120 | 80 | 52 | 5.5 | 1.78 |
| | AX-RAI03500100-DE | 120 | 80 | 120 | 80 | 62 | 5.5 | 2.35 |
| | AX-RAI01300170-DE | 120 | 80 | 120 | 80 | 62 | 5.5 | 2.50 |
| | AX-RAI00740335-DE | 180 | 85 | 190 | 140 | 55 | 6 | 5.5 |



DC Reactor

| Voltage | Reference | Dimensions | | | | | | | | Weight kg |
|------------------|------------------|------------|-----|-------|-----|-----|-----|-----|------|-----------|
| | | A | B | C | D | E | F | G | H | |
| 200 V | AX-RC21400016-DE | 84 | 113 | 96 | 101 | 66 | 5 | 7.5 | 2 | 1.22 |
| | AX-RC10700032-DE | | | 105 | | | | | | |
| | AX-RC06750061-DE | | | 116 | | | | | | |
| | AX-RC03510093-DE | | | 116 | | | | | | |
| | AX-RC02510138-DE | 108 | 135 | 124 | 120 | 82 | 6.5 | 9.5 | 3.20 | |
| | AX-RC01600223-DE | 120 | 152 | 136 | 135 | 94 | 7 | - | - | 5.20 |
| | AX-RC01110309-DE | | | 146 | | | | | | 6.00 |
| | AX-RC00840437-DE | 150 | 177 | 160 | 160 | 115 | 7 | 2 | - | 11.4 |
| | AX-RC00590614-DE | | | 182.6 | | | | | | 14.3 |
| AX-RC00440859-DE | 182.6 | | | 14.3 | | | | | | |
| 400 V | AX-RC43000020-DE | 84 | 113 | 96 | 101 | 66 | 5 | 7.5 | 2 | 1.22 |
| | AX-RC27000030-DE | | | 105 | | | | | | |
| | AX-RC14000047-DE | | | 116 | | | | | | |
| | AX-RC10100069-DE | | | 131 | | | | | | |
| | AX-RC08250093-DE | 108 | 135 | 133 | 120 | 82 | 6.5 | 9.5 | 3.70 | |
| | AX-RC06400116-DE | 120 | 152 | 136 | 135 | 94 | 7 | - | - | 5.20 |
| | AX-RC04410167-DE | | | 146 | | | | | | 6.00 |
| | AX-RC03350219-DE | 150 | 177 | 160 | 160 | 115 | 7 | 2 | - | 11.4 |
| | AX-RC02330307-DE | | | 182.6 | | | | | | 14.3 |
| AX-RC01750430-DE | 182.6 | | | 14.3 | | | | | | |



Output AC Reactor

| Voltage | Reference | Dimensions | | | | | | Weight kg |
|---------|-------------------|------------|-----|-----|-----|----|-----|-----------|
| | | A | B2 | C2 | D | E | F | |
| 200 V | AX-RAO11500026-DE | 120 | 70 | 120 | 80 | 52 | 5.5 | 1.78 |
| | AX-RAO07600042-DE | 120 | 70 | 120 | 80 | 52 | 5.5 | 1.78 |
| | AX-RAO04100075-DE | 120 | 80 | 120 | 80 | 62 | 5.5 | 2.35 |
| | AX-RAO03000105-DE | 120 | 80 | 120 | 80 | 62 | 5.5 | 2.35 |
| | AX-RAO01830180-DE | 180 | 85 | 190 | 140 | 55 | 6 | 5.5 |
| | AX-RAO01150220-DE | 180 | 85 | 190 | 140 | 55 | 6 | 5.5 |
| | AX-RAO00950320-DE | 180 | 85 | 205 | 140 | 55 | 6 | 6.5 |
| | AX-RAO00630430-DE | 180 | 95 | 205 | 140 | 65 | 6 | 9.1 |
| | AX-RAO00490640-DE | 180 | 95 | 205 | 140 | 65 | 6 | 9.1 |
| 400 V | AX-RAO16300038-DE | 120 | 70 | 120 | 80 | 52 | 5.5 | 1.78 |
| | AX-RAO11800053-DE | 120 | 80 | 120 | 80 | 52 | 5.5 | 2.35 |
| | AX-RAO07300080-DE | 120 | 80 | 120 | 80 | 62 | 5.5 | 2.35 |
| | AX-RAO04600110-DE | 180 | 85 | 190 | 140 | 55 | 6 | 5.5 |
| | AX-RAO03600160-DE | 180 | 85 | 205 | 140 | 55 | 6 | 6.5 |
| | AX-RAO02500220-DE | 180 | 95 | 205 | 140 | 55 | 6 | 9.1 |
| | AX-RAO02000320-DE | 180 | 105 | 205 | 140 | 85 | 6 | 11.7 |

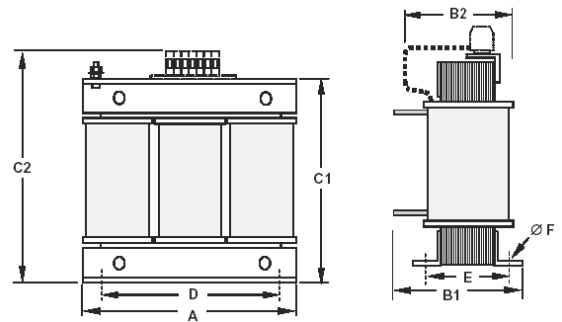

Chokes

| Reference | D diameter | Motor kW | Dimensions | | | | | | Weight kg |
|---------------|------------|----------|------------|----|-----|-----|----|---|-----------|
| | | | L | W | H | X | Y | m | |
| AX-FER2102-RE | 21 | < 2.2 | 85 | 22 | 46 | 70 | - | 5 | 0.1 |
| AX-FER2515-RE | 25 | < 15 | 105 | 25 | 62 | 90 | - | 5 | 0.2 |
| AX-FER5045-RE | 50 | < 45 | 150 | 50 | 110 | 125 | 30 | 5 | 0.7 |

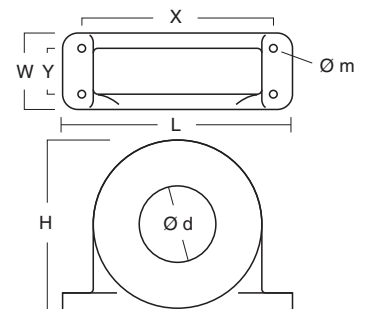

Resistor dimensions



| Type | Fig. | Dimensions | | | | | | | Weight |
|------------------|------|------------|-----|-----|-----|-----|----|-----|--------|
| | | L | H | M | I | T | G | N | kg |
| AX-REM00K1400-IE | 1 | 105 | 27 | 36 | 94 | - | - | - | 0.2 |
| AX-REM00K2070-IE | | | | | | | | | |
| AX-REM00K2120-IE | | | | | | | | | |
| AX-REM00K2200-IE | | | | | | | | | |
| AX-REM00K4075-IE | | | | | | | | | |
| AX-REM00K4035-IE | 2 | 200 | 61 | 100 | 74 | 211 | 40 | 230 | 1.41 |
| AX-REM00K4030-IE | | | | | | | | | |
| AX-REM00K5120-IE | | | | | | | | | |
| AX-REM00K6100-IE | | | | | | | | | |
| AX-REM00K6035-IE | | | | | | | | | |
| AX-REM00K9070-IE | 3 | 365 | 73 | 105 | 350 | 70 | - | - | 4 |
| AX-REM00K9020-IE | | | | | | | | | |
| AX-REM01K9070-IE | 4 | 310 | 100 | 240 | 295 | 210 | - | - | 7 |
| AX-REM01K9017-IE | | | | | | | | | |
| AX-REM02K1070-IE | | | | | | | | | |
| AX-REM02K1017-IE | | | | | | | | | |
| AX-REM03K5035-IE | 4 | 365 | 100 | 240 | 350 | 210 | - | - | 8 |
| AX-REM03K5010-IE | | | | | | | | | |

Standard connections



Terminal Block Specifications

| Terminal | Name | Function (signal level) |
|------------------|------------------------------------|--|
| R/L1, S/L2, T/L3 | Main circuit power supply input | Used to connect line power to the drive. Drives with single-phase 200 V input power use only terminals R/L1 and N (T/L3), terminal S/L2 is not available for these units |
| U/T1, V/T2, W/T3 | Inverter output | Used to connect the motor |
| PD/+1, P/+ | External DC reactor terminal | Normally connected by the short-circuit bar. Remove the short-circuit bar between +1 and P/+2 when a DC reactor is connected. |
| P/+, N/- | Regenerative braking unit terminal | Connect optional regenerative braking units (if a braking torque is required) |
| P/+, RB | Braking resistor terminals | Connect option braking resistor (if a braking torque is required) |
| ⊕ | Grounding | For grounding (grounding should conform to the local grounding code.) |

Control Circuit

| Type | No. | Signal name | Function | Signal level |
|------------------------|--------|---|--|--|
| Digital input signals | PLC | Intelligent input common | Source type: connecting [P24] to [1]-[7] turns inputs ON Sink type: connecting [L] to [1]-[7] turns inputs ON | - |
| | P24 | Internal 24 VDC | 24 VDC, 30mA | 24 VDC, 100 mA |
| | 1 | Multi-function Input selection 1 | Factory setting: Forward/ Stop | 27 VDC max |
| | 2 | Multi-function Input selection 2 | Factory setting: Reverse/ Stop | |
| | 3/GS1 | Multi-function Input selection 3 / safe stop input 1 | Factory setting: External trip | |
| | 4/GS2 | Multi-function Input selection 4 / safe stop input 2 | Factory setting: Reset | |
| | 5/PTC | Multi-function Input selection 5 / PTC thermistor input | Factory setting: Multi-step speed reference 1 | |
| | 6 | Multi-function input selection 6 | Factory setting: Multi-step speed reference 2 | |
| | 7/EB | Multi-function input selection 7 / Pulse train input B | Factory setting: Jog | |
| | L | Multi-function Input selection common (in upper row) | -- | |
| Pulse train | EA | Pulse train input A | Factory setting: Speed reference | 32 kHz max 5 to 24 VDC |
| | EO | Pulse train output | LAD frequency | 10 VDC 2 mA 32 kHz max |
| Analog input signal | H | Frequency reference power supply | 10 VDC 10 mA max | |
| | O | Voltage frequency reference signal | 0 to 10 VDC (10 kΩ) | |
| | OI | Current frequency reference signal | 4 to 20 mA (250 Ω) | |
| | L | Frequency reference common (bottom row) | -- | |
| Digital output signals | 11/EDM | Discrete logic output 1 / EDM output | Factory setting: During Run | 27 VDC, 50 mA max EDM based on ISO13849-1 |
| | 12 | Discrete logic output 2 | Factory setting: Frequency arrival type 1 | |
| | CM2 | GND logic output | -- | |
| | AL0 | Relay common contact | Factory setting: Alarm signal | R load 250 VAC 2.5 A 30 VDC 3.0 A I load 250 VAC 0.2 A 30 VDC 0.7 A |
| | AL1 | Relay contact, normally open | Under normal operation AL1 - AL0 Closed | |
| | AL2 | Relay contact, normally closed | AL2 - AL0 Open | |
| Monitor Signal | AM | Analog voltage output | Factory setting: LAD frequency | 0 to 10 VDC 1 mA |
| Comms | SP | Serial communication terminal | RS485 Modbus communication | |
| | SN | | | |

Side by side mounting



Inverter heat loss

Single-phase 200 V class

| Model 3G3MX2 | | AB001 | AB002 | AB004 | AB007 | AB015 | AB022 |
|--------------------------|---------|--------------|-------|-------|-------|--------------------|-------|
| Inverter capacity kVA | 200V VT | 0.4 | 0.6 | 1.2 | 2.0 | 3.3 | 4.1 |
| | 200V CT | 0.2 | 0.5 | 1.0 | 1.7 | 2.7 | 3.8 |
| | 240V VT | 0.4 | 0.7 | 1.4 | 2.4 | 3.9 | 4.9 |
| | 240V CT | 0.3 | 0.6 | 1.2 | 2.0 | 3.3 | 4.5 |
| Rated current (A) VT | | 1.2 | 1.9 | 3.4 | 6.0 | 9.6 | 12.0 |
| Rated current (A) CT | | 1.0 | 1.6 | 3.0 | 5.0 | 8.0 | 11.0 |
| Total heat loss | | 12 | 22 | 30 | 48 | 79 | 104 |
| Efficiency at rated load | | 89.5 | 90 | 93 | 94 | 95 | 95.5 |
| Cooling Method | | Self cooling | | | | Forced-air-cooling | |

Three-phase 200 V class

| Model 3G3MX2 | | A2001 | A2002 | A2004 | A2007 | A2015 | A2022 | A2037 | A2055 | A2075 | A2110 | A2150 |
|--------------------------|--------|--------------|-------|-------|-------|-------|--------------------|-------|-------|-------|-------|-------|
| Inverter capacity kVA | 200 VT | 0.4 | 0.6 | 1.2 | 2.0 | 3.3 | 4.1 | 6.7 | 10.3 | 13.8 | 19.3 | 23.9 |
| | 200 CT | 0.2 | 0.5 | 1.0 | 1.7 | 2.7 | 3.8 | 6.0 | 8.6 | 11.4 | 16.2 | 20.7 |
| | 240 VT | 0.4 | 0.7 | 1.4 | 2.4 | 3.9 | 4.9 | 8.1 | 12.4 | 16.6 | 23.2 | 28.6 |
| | 240 CT | 0.3 | 0.6 | 1.2 | 2.0 | 3.3 | 4.5 | 7.2 | 10.3 | 13.7 | 19.5 | 24.9 |
| Rated current (A) VT | | 1.2 | 1.9 | 3.4 | 6.0 | 9.6 | 12.0 | 19.6 | 30.0 | 40.0 | 56.0 | 69.0 |
| Rated current (A) CT | | 1.0 | 1.6 | 3.0 | 5.0 | 8.0 | 11.0 | 17.5 | 25.0 | 33.0 | 47.0 | 60.0 |
| Total heat loss | | 12 | 22 | 30 | 48 | 79 | 104 | 154 | 229 | 313 | 458 | 625 |
| Efficiency at rated load | | 89.5 | 90 | 93 | 94 | 95 | 95.5 | 96 | 96 | 96 | 96 | 96 |
| Cooling Method | | Self cooling | | | | | Forced-air-cooling | | | | | |

Three-phase 400 V class

| Model 3G3MX2 | | A4004 | A4007 | A4015 | A4022 | A4030 | A4040 | A4055 | A4075 | A4110 | A4150 | |
|--------------------------|---------|--------------|-------|-------|-------|-------|--------------------|-------|-------|-------|-------|--|
| Inverter capacity kVA | 380V VT | 1.3 | 2.6 | 3.5 | 4.5 | 5.7 | 7.3 | 11.5 | 15.1 | 20.4 | 25.0 | |
| | 380V CT | 1.1 | 2.2 | 3.1 | 3.6 | 4.7 | 6.0 | 9.7 | 11.8 | 15.7 | 20.4 | |
| | 480V VT | 1.7 | 3.4 | 4.4 | 5.7 | 7.3 | 9.2 | 14.5 | 19.1 | 25.7 | 31.5 | |
| | 480V CT | 1.4 | 2.8 | 3.9 | 4.5 | 5.9 | 7.6 | 12.3 | 14.9 | 19.9 | 25.7 | |
| Rated current (A) VT | | 2.1 | 4.1 | 5.4 | 6.9 | 8.8 | 11.1 | 17.5 | 23.0 | 31.0 | 38.0 | |
| Rated current (A) CT | | 1.8 | 3.4 | 4.8 | 5.5 | 7.2 | 9.2 | 14.8 | 18.0 | 24.0 | 31.0 | |
| Total heat loss | | 35 | 56 | 96 | 116 | 125 | 167 | 229 | 296 | 411 | 528 | |
| Efficiency at rated load | | 92 | 93 | 94 | 95 | 96 | 96 | 96 | 96.2 | 96.4 | 96.6 | |
| Cooling Method | | Self cooling | | | | | Forced-air-cooling | | | | | |

Input AC Reactor



| 1 phase 200 V class | | | | 3 phase 200 V class | | | | 400 V class | | | |
|---------------------------------|-------------------|-----------------|---------------|---------------------------------|-------------------|-----------------|---------------|---------------------------------|-------------------|-----------------|---------------|
| Max. applicable motor output kW | Reference | Current value A | Inductance mH | Max. applicable motor output kW | Reference | Current value A | Inductance mH | Max. applicable motor output kW | Reference | Current value A | Inductance mH |
| 0.4 | AX-RAI02000070-DE | 7.0 | 2.0 | 1.5 | AX-RAI02800080-DE | 8.0 | 2.8 | 1.5 | AX-RAI07700050-DE | 5.0 | 7.7 |
| 0.75 | AX-RAI01700140-DE | 14.0 | 1.7 | 3.7 | AX-RAI00880200-DE | 20.0 | 0.88 | 4.0 | AX-RAI03500100-DE | 10.0 | 3.5 |
| 1.5 | AX-RAI01200200-DE | 20.0 | 1.2 | 7.5 | AX-RAI00350335-DE | 33.5 | 0.35 | 7.5 | AX-RAI01300170-DE | 17.0 | 1.3 |
| 2.2 | AX-RAI00630240-DE | 24.0 | 0.63 | 15 | AX-RAI00180670-DE | 67.0 | 0.18 | 15 | AX-RAI00740335-DE | 33.5 | 0.74 |

DC Reactor



| 200 V class | | | | 400 V class | | | |
|---------------------------------|------------------|-----------------|---------------|---------------------------------|------------------|-----------------|---------------|
| Max. applicable motor output kW | Reference | Current value A | Inductance mH | Max. applicable motor output kW | Reference | Current value A | Inductance mH |
| 0.2 | AX-RC21400016-DE | 1.6 | 21.4 | 0.4 | AX-RC43000020-DE | 2.0 | 43.0 |
| 0.4 | AX-RC10700032-DE | 3.2 | 10.7 | 0.7 | AX-RC27000030-DE | 3.0 | 27.0 |
| 0.7 | AX-RC06750061-DE | 6.1 | 6.75 | 1.5 | AX-RC14000047-DE | 4.7 | 14.0 |
| 1.5 | AX-RC03510093-DE | 9.3 | 3.51 | 2.2 | AX-RC10100069-DE | 6.9 | 10.1 |
| 2.2 | AX-RC02510138-DE | 13.8 | 2.51 | 3.0 | AX-RC08250093-DE | 9.3 | 8.25 |
| 3.7 | AX-RC01600223-DE | 22.3 | 1.60 | 4.0 | AX-RC06400116-DE | 11.6 | 6.40 |
| 5.5 | AX-RC01110309-DE | 30.9 | 1.11 | 5.5 | AX-RC04410167-DE | 16.7 | 4.41 |
| 7.5 | AX-RC00840437-DE | 43.7 | 0.84 | 7.5 | AX-RC03350219-DE | 21.9 | 3.35 |
| 11.0 | AX-RC00590614-DE | 61.4 | 0.59 | 11.0 | AX-RC02330307-DE | 30.7 | 2.33 |
| 15.0 | AX-RC00440859-DE | 85.9 | 0.44 | 15.0 | AX-RC01750430-DE | 43.0 | 1.75 |

Output AC Reactor

| 200 V class | | | | 400 V class | | | |
|---------------------------------|-------------------|-----------------|---------------|---------------------------------|-------------------|-----------------|---------------|
| Max. applicable motor output kW | Reference | Current value A | Inductance mH | Max. applicable motor output kW | Reference | Current value A | Inductance mH |
| 0.4 | AX-RAO11500026-DE | 2.6 | 11.50 | 1.5 | AX-RAO16300038-DE | 3.8 | 16.30 |
| 0.75 | AX-RAO07600042-DE | 4.2 | 7.60 | | | | |
| 1.5 | AX-RAO04100075-DE | 7.5 | 4.10 | | | | |
| 2.2 | AX-RAO03000105-DE | 10.5 | 3.00 | 2.2 | AX-RAO11800053-DE | 5.3 | 11.80 |
| 3.7 | AX-RAO01830160-DE | 16.0 | 1.83 | 4.0 | AX-RAO07300080-DE | 8.0 | 7.30 |
| 5.5 | AX-RAO01150220-DE | 22.0 | 1.15 | 5.5 | AX-RAO04600110-DE | 11.0 | 4.60 |
| 7.5 | AX-RAO00950320-DE | 32.0 | 0.95 | 7.5 | AX-RAO03600160-DE | 16.0 | 3.60 |
| 11 | AX-RAO00630430-DE | 43.0 | 0.63 | 11 | AX-RAO02500220-DE | 22.0 | 2.50 |
| 15 | AX-RAO00490640-DE | 64.0 | 0.49 | 15 | AX-RAO02000320-DE | 32.0 | 2.00 |

Ordering information



3G3MX2

| Specifications | | | | | Model | | |
|-----------------------|-----------------|-----------------|-----------------|-----------------|-----------------|------------------|-------------------|
| Voltage class | Constant torque | | Variable torque | | Standard (IP20) | Finless | IP54 |
| | Max motor kW | Rated current A | Max motor kW | Rated current A | | | |
| Single-phase 200 V | 0.1 | 1.0 | 0.2 | 1.2 | 3G3MX2-AB001-E | 3G3MX2-AB001-P-E | 3G3MX2-DB001-E/EC |
| | 0.2 | 1.6 | 0.4 | 1.9 | 3G3MX2-AB002-E | 3G3MX2-AB002-P-E | 3G3MX2-DB002-E/EC |
| | 0.4 | 3.0 | 0.55 | 3.5 | 3G3MX2-AB004-E | 3G3MX2-AB004-P-E | 3G3MX2-DB004-E/EC |
| | 0.75 | 5.0 | 1.1 | 6.0 | 3G3MX2-AB007-E | 3G3MX2-AB007-P-E | 3G3MX2-DB007-E/EC |
| | 1.5 | 8.0 | 2.2 | 9.6 | 3G3MX2-AB015-E | 3G3MX2-AB015-P-E | 3G3MX2-DB015-E/EC |
| | 2.2 | 11.0 | 3.0 | 12.0 | 3G3MX2-AB022-E | 3G3MX2-AB022-P-E | 3G3MX2-DB022-E/EC |
| Three-phase 200 V | 0.1 | 1.0 | 0.2 | 1.2 | 3G3MX2-A2001-E | 3G3MX2-A2001-P-E | 3G3MX2-D2001-E/EC |
| | 0.2 | 1.6 | 0.4 | 1.9 | 3G3MX2-A2002-E | 3G3MX2-A2002-P-E | 3G3MX2-D2002-E/EC |
| | 0.4 | 3.0 | 0.55 | 3.5 | 3G3MX2-A2004-E | 3G3MX2-A2004-P-E | 3G3MX2-D2004-E/EC |
| | 0.75 | 5.0 | 1.1 | 6.0 | 3G3MX2-A2007-E | 3G3MX2-A2007-P-E | 3G3MX2-D2007-E/EC |
| | 1.5 | 8.0 | 2.2 | 9.6 | 3G3MX2-A2015-E | 3G3MX2-A2015-P-E | 3G3MX2-D2015-E/EC |
| | 2.2 | 11.0 | 3.0 | 12.0 | 3G3MX2-A2022-E | 3G3MX2-A2022-P-E | 3G3MX2-D2022-E/EC |
| | 3.7 | 17.5 | 5.5 | 19.6 | 3G3MX2-A2037-E | 3G3MX2-A2037-P-E | 3G3MX2-D2037-E/EC |
| | 5.5 | 25.0 | 7.5 | 30.0 | 3G3MX2-A2055-E | - | 3G3MX2-D2055-E/EC |
| | 7.5 | 33.0 | 11 | 40.0 | 3G3MX2-A2075-E | - | 3G3MX2-D2075-E/EC |
| | 15 | 60.0 | 18.5 | 69.0 | 3G3MX2-A2150-E | - | 3G3MX2-D2150-E/EC |
| Three-phase 400 V | 0.4 | 1.8 | 0.75 | 2.1 | 3G3MX2-A4004-E | 3G3MX2-A4004-P-E | 3G3MX2-D4004-E/EC |
| | 0.75 | 3.4 | 1.5 | 4.1 | 3G3MX2-A4007-E | 3G3MX2-A4007-P-E | 3G3MX2-D4007-E/EC |
| | 1.5 | 4.8 | 2.2 | 5.4 | 3G3MX2-A4015-E | 3G3MX2-A4015-P-E | 3G3MX2-D4015-E/EC |
| | 2.2 | 5.5 | 3.0 | 6.9 | 3G3MX2-A4022-E | 3G3MX2-A4022-P-E | 3G3MX2-D4022-E/EC |
| | 3.0 | 7.2 | 4.0 | 8.8 | 3G3MX2-A4030-E | 3G3MX2-A4030-P-E | 3G3MX2-D4030-E/EC |
| | 4.0 | 9.2 | 5.5 | 11.1 | 3G3MX2-A4040-E | 3G3MX2-A4040-P-E | 3G3MX2-D4040-E/EC |
| | 5.5 | 14.8 | 7.5 | 17.5 | 3G3MX2-A4055-E | - | 3G3MX2-D4055-E/EC |
| | 7.5 | 18.0 | 11 | 23.0 | 3G3MX2-A4075-E | - | 3G3MX2-D4075-E/EC |
| | 15 | 31.0 | 18.5 | 38.0 | 3G3MX2-A4150-E | - | 3G3MX2-D4150-E/EC |

① Line filters

| Inverter | | Standard line filter | | | | Low leakage line filter | | | |
|-------------------|-------------------------------|----------------------|-------------|------------------|-------------|-------------------------|-------------|------------------|-------------|
| | | Rasmi | | Schaffner | | Rasmi | | Schaffner | |
| Voltage | Model 3G3MX2-□ | Reference AX-FIM | Current (A) | Reference AX-FIM | Current (A) | Reference AX-FIM | Current (A) | Reference AX-FIM | Current (A) |
| 1Phase 200 VAC | AB001 / AB002 / AB004 | 1010-RE | 10 | 1010-SE-V1 | 8 | 1010-RE-LL | 10 | 1010-SE-LL | 10 |
| | AB007 | 1014-RE | 14 | 1014-SE-V1 | 14 | 1014-RE-LL | 14 | 1014-SE-LL | 14 |
| | AB015 / AB022 | 1024-RE | 24 | 1024-SE-V1 | 27 | 1024-RE-LL | 24 | 1024-SE-LL | 24 |
| 3Phase 200 VAC | A2001 / A2002 / A2004 / A2007 | 2010-RE | 10 | 2010-SE-V1 | 7.8 | 2010-RE-LL | 10 | - | - |
| | A2015 / A2022 | 2020-RE | 20 | 2020-SE-V1 | 16 | 2020-RE-LL | 20 | 2020-SE-LL | 20 |
| | A2037 | 2030-RE | 30 | 2030-SE-V1 | 25 | 2030-RE-LL | 30 | 2030-SE-LL | 30 |
| | A2055 / A2075 | 2060-RE | 60 | 2060-SE-V1 | 50 | 2060-RE-LL | 60 | 2060-SE-LL | 50 |
| | A2110 | 2080-RE | 80 | 2080-SE-V1 | 70 | 2080-RE-LL | 80 | - | - |
| A2150 | 2100-RE | 100 | 2100-SE-V1 | 75 | 2100-RE-LL | 100 | - | - | |
| 3Phase 400 VAC | A4004 / A4007 | 3005-RE | 5 | 3005-SE-V1 | 6 | 3005-RE-LL | 5 | 3005-SE-LL | 5 |
| | A4015 / A4022 / A4030 | 3010-RE | 10 | 3010-SE-V1 | 12 | 3010-RE-LL | 10 | 3010-SE-LL | 10 |
| | A4040 | 3014-RE | 14 | 3014-SE-V1 | 15 | 3014-RE-LL | 14 | 3014-SE-LL | 15 |
| | A4055 / A4075 | 3030-RE | 30 | 3030-SE-V1 | 29 | 3030-RE-LL | 30 | 3030-SE-LL | 30 |
| A4110 / A4150 | 3050-RE | 50 | 3050-SE-V1 | 48 | 3050-RE-LL | 50 | 3050-SE-LL | 50 | |

① Input AC reactors

| Inverter | | AC Reactor |
|-----------------|-----------------------|-------------------|
| Voltage | Model 3G3MX2-□ | Reference |
| 1-Phase 200 VAC | AB002 / AB004 | AX-RAI02000070-DE |
| | AB007 | AX-RAI01700140-DE |
| | AB015 | AX-RAI01200200-DE |
| | AB022 | AX-RAI00630240-DE |
| 3-Phase 200 VAC | A2002 / A2004 / A2007 | AX-RAI02800080-DE |
| | A2015 / A2022 / A2037 | AX-RAI00880200-DE |
| | A2055 / A2075 | AX-RAI00350335-DE |
| | A2110 / A2150 | AX-RAI00180670-DE |
| 3-Phase 400 VAC | A4004 / A4007 / A4015 | AX-RAI07700050-DE |
| | A4022 / A4030 / A4040 | AX-RAI03500100-DE |
| | A4055 / A4075 | AX-RAI01300170-DE |
| | A4110 / A4150 | AX-RAI00740335-DE |

① DC reactors

| 200V 1-phase | | 200V 3-phase | | 400V 3-phase | |
|--------------|------------------|--------------|------------------|--------------|------------------|
| Inverter | DC Reactor | Inverter | DC Reactor | Inverter | DC Reactor |
| 3G3MX2-AB001 | AX-RC10700032-DE | 3G3MX2-A2001 | AX-RC21400016-DE | 3G3MX2-A4004 | AX-RC43000020-DE |
| 3G3MX2-AB002 | | 3G3MX2-A2002 | | 3G3MX2-A4007 | AX-RC27000030-DE |
| 3G3MX2-AB004 | AX-RC06750061-DE | 3G3MX2-A2004 | AX-RC10700032-DE | 3G3MX2-A4015 | AX-RC14000047-DE |
| 3G3MX2-AB007 | AX-RC03510093-DE | 3G3MX2-A2007 | AX-RC06750061-DE | 3G3MX2-A4022 | AX-RC10100069-DE |
| 3G3MX2-AB015 | AX-RC02510138-DE | 3G3MX2-A2015 | AX-RC03510093-DE | 3G3MX2-A4030 | AX-RC08250093-DE |
| 3G3MX2-AB022 | AX-RC01600223-DE | 3G3MX2-A2022 | AX-RC02510138-DE | 3G3MX2-A4040 | AX-RC06400116-DE |
| - | - | 3G3MX2-A2037 | AX-RC01600223-DE | 3G3MX2-A4055 | AX-RC04410167-DE |
| | | 3G3MX2-A2055 | AX-RC01110309-DE | 3G3MX2-A4075 | AX-RC03350219-DE |
| | | 3G3MX2-A2075 | AX-RC00840437-DE | 3G3MX2-A4011 | AX-RC02330307-DE |
| | | 3G3MX2-A2011 | AX-RC00590614-DE | 3G3MX2-A4015 | AX-RC01750430-DE |
| | | 3G3MX2-A2015 | AX-RC00440859-DE | - | - |

① Chokes

| Model | Diameter | Description |
|---------------|----------|----------------------------|
| AX-FER2102-RE | 21 | For 2.2 KW motors or below |
| AX-FER2515-RE | 25 | For 15 KW motors or below |
| AX-FER5045-RE | 50 | For 45 KW motors or below |

① Output AC reactor

| Voltage | Inverter | AC Reactor |
|---------|--|-------------------|
| | Model 3G3MX2-□ | Reference |
| 200 VAC | AB001 / AB002 / AB004 A2001 / A2002 / A2004 | AX-RAO11500026-DE |
| | AB007 / A2007 | AX-RAO07600042-DE |
| | AB015 / A2015 | AX-RAO04100075-DE |
| | AB022 / A2022 | AX-RAO03000105-DE |
| | A2037 | AX-RAO01830160-DE |
| | A2055 | AX-RAO01150220-DE |
| | A2075 | AX-RAO00950320-DE |
| | A2110 | AX-RAO00630430-DE |
| 400 VAC | A2150 | AX-RAO00490640-DE |
| | A4004 / A4007 / A4015 | AX-RAO16300038-DE |
| | A4022 | AX-RAO11800053-DE |
| | A4030 / A4040 | AX-RAO07300080-DE |
| | A4055 | AX-RAO04600110-DE |
| | A4075 | AX-RAO03600160-DE |
| | A4110 | AX-RAO02500220-DE |
| A4150 | AX-RAO02000320-DE | |

② Accessories

| Types | Model | Description | Functions |
|------------------|-------------------|-------------------------------|--|
| Digital operator | AX-OP05-E | LCD remote operator | 5 Line LCD remote operator with copy function, cable length max. 3m. |
| | 3G3AX-CAJOP300-EE | Remote operator cable | 3 meters cable for connecting remote operator |
| | 3G3AX-OP01 | LED remote operator | LED remote operator, cable length max. 3m |
| | 4X-KITMINI | Mounting kit for LED operator | Mounting kit for LED operator on panel |
| | 3G3AX-OP05-H-E | Operator holder | Holder to put the AX-OP05-E inside of the cabinet |
| Accessories | AX-CUSBM002-E | PC configuration cable | Mini USB to USB connector cable |

③ Communication option boards

| Types | Model | Description | Functions |
|-----------------------|-------------------|---------------------------------|--|
| Communication options | 3G3AX-MX2-PRT | Profibus option card | Used for running or stopping the inverter, setting or referencing parameters, and monitoring output frequency, output current, or similar items through communications with the host controller. |
| | 3G3AX-MX2-DRT | DeviceNet option card | |
| | 3G3AX-MX2-ECT | EtherCAT option card | |
| | 3G3AX-MX2-CRT | CompoNet option card | |
| | 3G3AX-MX2-MRT | MECHATROLINK-II option card | |
| | 3G3AX-MX2-EIP | EtherNet/IP option card | |
| I/O option | 3G3AX-MX2-EIO15-E | Extra input/output option board | 1 analog voltage input, 1 analog current input, 1 analog voltage output, 8 discrete logic inputs, 4 discrete logic outputs |

④ Braking unit, braking resistor unit

| Inverter | | | | Braking resistor unit | | | | | | |
|-----------------------------|---------------|------------------|---------|-------------------------------|---|----------|------------------|---|----------|------------------|
| Voltage | Max. motor kW | Inverter 3G3MX2□ | | Connectable min. resistance Ω | Inverter mounted type (3 %ED, 10 sec max) | | Braking torque % | Inverter mounted type (10%ED, 10 sec max) | | Braking torque % |
| | | 1-phase | 3-phase | | Type AX- | Resist Ω | | Type AX- | Resist Ω | |
| 200 V (Single-/Three-phase) | 0.12 | B001 | 2001 | 100 | REM00K1400-IE | 400 | 200 | REM00K1400-IE | 400 | 200 |
| | 0.25 | B002 | 2002 | | | | 180 | | | 180 |
| | 0.55 | B004 | 2004 | | | | 180 | | | 200 |
| | 1.1 | B007 | 2007 | 50 | REM00K1200-IE | 200 | 100 | REM00K2070-IE | 70 | 200 |
| | 1.5 | B015 | 2015 | | | | 140 | REM00K4075-IE | 75 | 130 |
| | 2.2 | B022 | 2022 | 35 | REM00K2070-IE | 70 | 90 | REM00K4035-IE | 35 | 180 |
| | 4.0 | - | 2040 | | | | 50 | REM00K6035-IE | 35 | 100 |
| | 5.5 | - | 2055 | 20 | REM00K4035-IE | 35 | 75 | REM00K9020-IE | 20 | 150 |
| | 7.5 | - | 2075 | | | | 55 | REM01K9017-IE | 17 | 110 |
| | 11 | - | 2110 | 17 | REM00K6035-IE | 35 | 40 | REM02K1017-IE | 17 | 75 |
| 15 | - | 2150 | 55 | | | | REM03K5010-IE | 10 | 95 | |
| 400 V (Three-phase) | 0.55 | - | 4004 | 180 | REM00K1400-IE | 400 | 200 | REM00K1400-IE | 400 | 200 |
| | 1.1 | - | 4007 | | | | 200 | | | 200 |
| | 1.5 | - | 4015 | | | | 190 | | | REM00K2200-IE |
| | 2.2 | - | 4022 | 100 | REM00K2200-IE | 200 | 130 | REM00K5120-IE | 120 | 200 |
| | 3.0 | - | 4030 | | | | 160 | | | 160 |
| | 4.0 | - | 4040 | 70 | REM00K2120-IE | 120 | 120 | REM00K6100-IE | 100 | 140 |
| | 5.5 | - | 4055 | | | | 140 | REM00K9070-IE | 70 | 150 |
| | 7.5 | - | 4075 | 70 | REM00K4075-IE | 75 | 100 | REM01K9070-IE | 70 | 110 |
| | 11 | - | 4110 | | | | 50 | REM02K1070-IE | 70 | 75 |
| | 15 | - | 4150 | 35 | REM00K9070-IE | 70 | 55 | REM03K5035-IE | 35 | 110 |

⑤ Computer software

| Types | Model | Description | Installation |
|----------|----------|-------------------|---|
| Software | CX-Drive | Computer software | Configuration and monitoring software tool |
| | CX-One | Computer software | Configuration and monitoring software tool |
| | €Saver | Computer software | Software tool for Energy Saving calculation |

ALL DIMENSIONS SHOWN ARE IN MILLIMETERS.
To convert millimeters into inches, multiply by 0.03937. To convert grams into ounces, multiply by 0.03527.

Would you like to know more?

OMRON EUROPE

 +31 (0) 23 568 13 00

 industrial.omron.eu

 omron.me/socialmedia_eu

Sales & Support Offices

Austria

Tel: +43 (0) 2236 377 800
industrial.omron.at

Belgium

Tel: +32 (0) 2 466 24 80
industrial.omron.be

Czech Republic

Tel: +420 234 602 602
industrial.omron.cz

Denmark

Tel: +45 43 44 00 11
industrial.omron.dk

Finland

Tel: +358 (0) 207 464 200
industrial.omron.fi

France

Tel: +33 (0) 1 56 63 70 00
industrial.omron.fr

Germany

Tel: +49 (0) 2173 680 00
industrial.omron.de

Hungary

Tel: +36 1 399 30 50
industrial.omron.hu

Italy

Tel: +39 02 326 81
industrial.omron.it

Netherlands

Tel: +31 (0) 23 568 11 00
industrial.omron.nl

Norway

Tel: +47 (0) 22 65 75 00
industrial.omron.no

Poland

Tel: +48 22 458 66 66
industrial.omron.pl

Portugal

Tel: +351 21 942 94 00
industrial.omron.pt

Russia

Tel: +7 495 648 94 50
industrial.omron.ru

South Africa

Tel: +27 (0)11 579 2600
industrial.omron.co.za

Spain

Tel: +34 902 100 221
industrial.omron.es

Sweden

Tel: +46 (0) 8 632 35 00
industrial.omron.se

Switzerland

Tel: +41 (0) 41 748 13 13
industrial.omron.ch

Turkey

Tel: +90 212 467 30 00
industrial.omron.com.tr

United Kingdom

Tel: +44 (0) 1908 258 258
industrial.omron.co.uk

More Omron representatives

industrial.omron.eu