

# Thermal Overload Relays

## TR series

### General information

#### Standard type thermal overload relays

##### ■ Description

- Highly reliable thermal overload relays
- FUJI thermal overload relays are designed to provide overload protection to meet the thermal characteristics of low voltage induction motors. Adjustable thermal overload relays give motors positive overcurrent protection. The starter contacts cannot be held closing under overload conditions. However, once the bimetal element has cooled, the reset button can be depressed and the motor can be restarted in the normal manner. Ordinarily this reset is carried out manually but the starter can be changed over to 'automatic reset' by means of a screw-driver.
- FUJI thermal overload relay is subjected to stringent testing in the factory to check performance and actual values are calibrated with the markings on the adjustable dial. Consequently, they provide a positive protection.
  - Relays are also provided with ambient temperature compensators, so that their performance will be maintained in spite of temperature changes. The ambient temperature is regulated for 20°C.
  - The heater elements are available for either 2- or 3-pole use.

##### Long time operating type

In the case of loads having large inertia moments such as blowers, winders or centrifuges the starting time is extended. This will cause the standard-type thermal overload relay to operate during starting so isolating the motor. If necessary FUJI will supply thermal relays with saturable reactors. (Time-delay type).

##### Quick operating type overload relays

The windings of submersible pump and compressor motors normally have a smaller overload capacity than those of standard motors, since they are generally cooled by the water and other medium being pumped. Q type overload relays will operate more quickly than the standard type in the face of a locked rotor current.

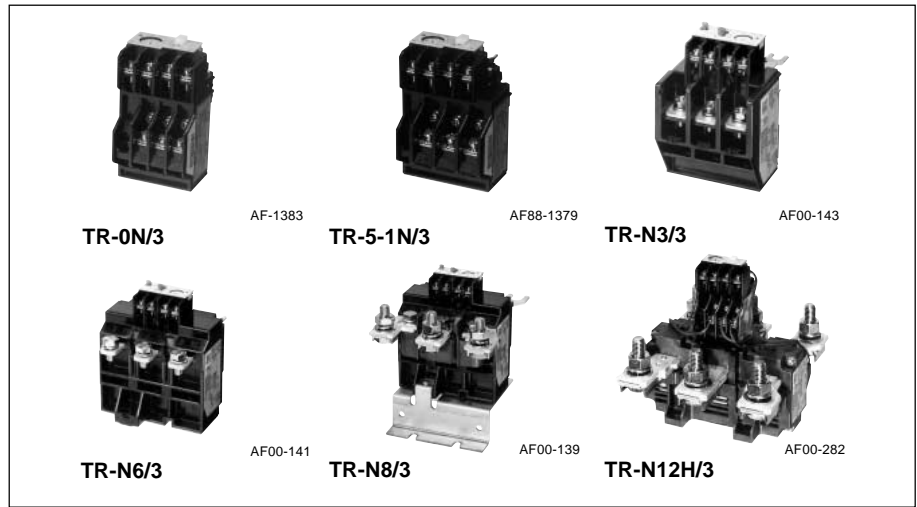

##### ■ Features

- Isolated NO and NC contacts can be used with different potentials.
- Gold-flashed silver contact assures high contact reliability (TR-0N/3 to N14/3).
- Stable operating characteristics protect motors from burnout due to overload or locked rotor currents.
- Easy setting of current value with a calibrated dial.
- Both manual and auto reset available. A manual trip button is provided to facilitate sequence testing.
- Mechanical trip indication
- Trip-free mechanism is provided.
- Reset release button and trip indicator are optional accessories.

##### ■ Warning

All FUJI thermal overload relays have been tested and calibrated at the factory. They should not be tampered with or stripped down at the job site since this would affect their accuracy. A special feature of the FUJI starter series is the ease by which the relay current ratings can be varied to match the requirements of the load. The changeover is effected by simply turning a dial to the new value required. The range of adjustment is approximately 100%–125%–150% and details are given overleaf.

##### ■ Ordering information

Specify the following:  
 1. Ordering code  
 2. Setting range code  
 See page 01/89.

##### ■ Type number nomenclature

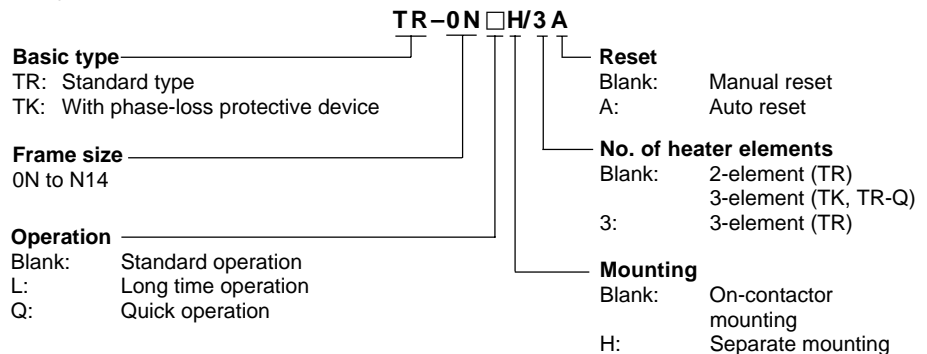

■ Ordering code system

T R 2 0 B N W — T A  
① ② ③④ ⑤ ⑥ ⑦ ⑧ ⑨

① Product category

Description	Code
Thermal overload relay	T

② Series category

Description	Code
TR-N□ series	R

③④ Frame size

Frame size	Code	
	③	④
0N	1	3
5-1N	2	0
N2	3	5
N3	6	5
N5	9	3
N6	1	C
N7	1	F
N8	1	J
N10	2	C
N12	4	A
N14	6	A

⑤ Index

Type	Code
TR-0N, 5-1N	Blank
TR-N2 to N14	B

⑥ Version

Description	No. of element	Code
Standard	2	N
	3	D
Long time operation	2	L
	3	F
Quick operation	3	S
With phase-loss	3	E

⑦ Mounting

Description	Code
On-contactor mounting	W
Separate mounting	H

⑨ Reset

Description	Code
Manual reset	Blank
Auto reaset	A

⑧ Thermal overload relay ampere setting range

Ampere setting range (A)	Code
0.1 — 0.15	A
0.13 — 0.2	B
0.15 — 0.24	C
0.2 — 0.3	D
0.24 — 0.36	E
0.3 — 0.45	F
0.36 — 0.54	G
0.48 — 0.72	H
0.64 — 0.96	J
0.8 — 1.2	K
0.95 — 1.45	L
1.4 — 2.2	M
1.7 — 2.6	N
2.2 — 3.4	P
2.8 — 4.2	R
4 — 6	S
5 — 8	T
6 — 9	U
7 — 11	V
9 — 13	W
12 — 18	X
16 — 22	Q
18 — 26	B
24 — 36	E
28 — 40	F
32 — 42	I
34 — 50	G
45 — 65	J
48 — 68	O
53 — 80	L
65 — 95	M
85 — 105	I
85 — 125	N
110 — 160	P
125 — 185	R
160 — 240	S
200 — 300	T
240 — 360	U
300 — 450	V
400 — 600	W

Ordering example

- ① Thermal overload relay ..... T
- ② TR-N□ series ..... R
- ③④ Frame size: 5-1N ..... 20
- ⑤ Index ..... Blank
- ⑥ Standard type, 3-element ..... D
- ⑦ On-contactor mounting ..... W
- ⑧ Ampere setting range 4-6A ..... S
- ⑨ Auto reset ..... A

- ① Thermal overload relay ..... T
- ② TR-N□ series ..... R
- ③④ Frame size: N3 ..... 65
- ⑤ Index ..... B
- ⑥ With phase-loss protection ..... E
- ⑦ On-contactor mounting ..... W
- ⑧ Ampere setting range 24-36A ..... E
- ⑨ Manual reset ..... Blank

TR20DW-SA

TR65BEW-E