

Features

1 & 2 Pole relay interface modules,
15.8 mm wide

Ideal interface for PLC and electronic systems

- 48.61 - 1 Pole 16 A (screw terminal)
- 48.81 - 1 Pole 16 A (screwless terminal)
- 48.62 - 2 Pole 10 A (screw terminal)
- 48.82 - 2 Pole 10 A (screwless terminal)

- AC coils or DC sensitive coils
- Instant ejection of relay using plastic retaining clip
- Supply status indication and EMC coil suppression module as standard
- Identification label
- UL Listing (certain relay/socket combinations)
- 35 mm rail (EN 60715) mounting

48.61 / 48.62
Screw terminal



48.81 / 48.82
Screwless terminal



For outline drawing see page 7

Contact specification

Contact configuration	1 CO (SPDT)	2 CO (DPDT)
Rated current/Maximum peak current	A 16*/30	10/20
Rated voltage/Maximum switching voltage V AC	250/400	250/400
Rated load AC1	VA 4,000	2,500
Rated load AC15 (230 V AC)	VA 750	500
Single phase motor rating (230 V AC)	kW 0.55	0.37
Breaking capacity DC1: 30/110/220V	A 16/0.3/0.12	10/0.3/0.12
Minimum switching load	mW (V/mA) 500 (10/5)	300 (5/5)
Standard contact material	AgCdO	AgNi
Coil specification		
Nominal voltage (U _N)	V AC (50/60 Hz)	12 - 24 - 110 - 120 - 230
	V DC	12 - 24 - 125
Rated power AC/sens. DC	VA (50 Hz)/W 1.2/0.5	-/0.5
Operating range	AC	(0.8...1.1)U _N
	sens. DC	(0.8...1.5)U _N
Holding voltage	AC/DC	0.8 U _N /0.4 U _N
Must drop-out voltage	AC/DC	0.2 U _N /0.1 U _N
Technical data		
Mechanical life AC/DC	cycles	10 · 10 ⁶ /20 · 10 ⁶
Electrical life at rated load AC1	cycles	100 · 10 ³
Operate/release time	ms	7/4 (AC) - 12/12 (DC)
Insulation between coil and contacts (1.2/50 μs)	kV	6 (8 mm)
Dielectric strength between open contacts	V AC	1,000
Ambient temperature range	°C	-40...+70
Protection category		IP 20

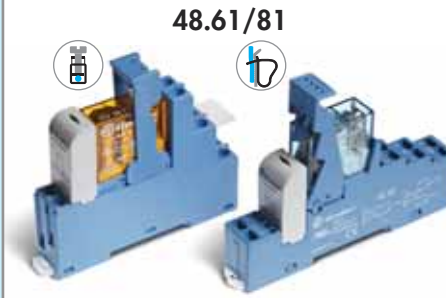

48.61/81

- 1 pole, 16 A
- Screw terminal and screwless terminal
- 35 mm rail (EN 60715) mounting

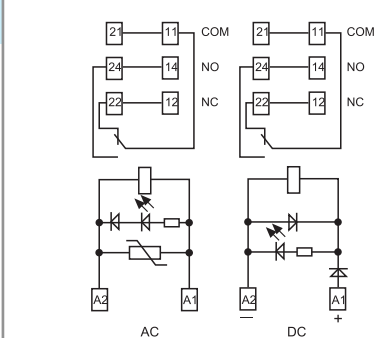

* For currents >10 A, contact terminals must be connected in parallel (21 with 11, 24 with 14, 22 with 12).

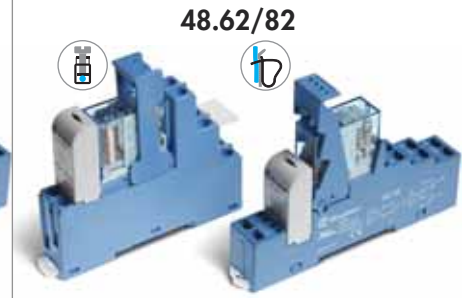

48.62/82

- 2 pole, 10 A
- Screw terminal and screwless terminal
- 35 mm rail (EN 60715) mounting

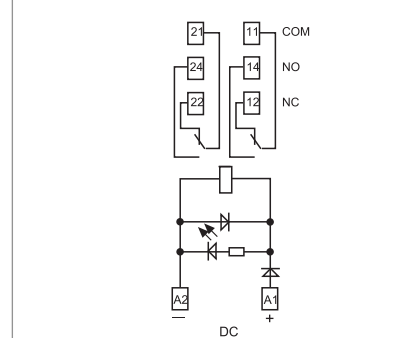

Ordering information

Example: 48 series, 35 mm rail (EN 60715) mount, screw terminal relay interface module, 2 CO (DPDT) 8 A contacts, 24 V sensitive DC coil, green LED + diode, 99.02 coil indication.

4	8	5	2	7	0	2	4	0	0	5	0
Series			Type			A: Contact material			D: Special versions		
Screw terminal			Screwless terminal			0 = Standard AgNi for 48.31/52/62/72/82 AgCdO, Standard for 48.61/81			0 = Standard		
1 = 35 mm rail (EN 60715) mount, safety relay			7 = 35 mm rail (EN 60715) mount			1 = AgNi, for 48.12			2 = Standard (for 48.12 only)		
3 = 35 mm rail (EN 60715) mount			8 = 35 mm rail (EN 60715) mount			4 = AgSnO ₂ , for 48.61/62/81/82 only			C: Options		
5 = 35 mm rail (EN 60715) mount						5 = AgNi + Au (5 µm), for 48.31/52/72 only			0 = Standard (for 48.12 only)		
6 = 35 mm rail (EN 60715) mount									5 = Standard for DC: green LED + diode (polarity +A1)		
									6 = Standard for AC: green LED + Varistor		
No. of poles						B: Contact circuit					
1 = 1 pole for 48.31, 10 A						0 = CO (nPDT)					
48.61, 48.81, 16 A											
2 = 2 pole for 48.12, 48.52, 48.72, 8 A											
48.62, 48.82, 10 A											
(48.62, 48.82 DC only)											
Coil version											
7 = Sensitive DC											
8 = AC (50/60 Hz)											
Coil voltage											
See coil specifications											

Selecting features and options: only combinations in the same row are possible.
Preferred selections for best availability are shown in **bold**.

Type	Coil version	A	B	C	D
48.12	DC	1	0	0	2
48.31/52/72	AC	0 - 2 - 5	0	6	0
48.31/52/72	DC	0 - 2 - 5	0	5	0
48.61/81	AC	0 - 4	0	6	0
48.61/81	DC	0 - 4	0	5	0
48.62/82	DC	0 - 4	0	5	0

Technical data

Insulation		48.12/31/61/62	48.52	48.12/31/61/62	
Insulation according to EN 61810-1	insulation rated voltage	V 250	250	400	
	rated impulse withstand voltage	kV 4	4	4	
	pollution degree	3	2	2	
	overvoltage category	III	III	III	
Insulation between coil and contacts (1.2/50 µs)		kV 6 (8 mm)			
Dielectric strength between open contacts		V AC 1,000; 1,500 (48.12)			
Dielectric strength between adjacent contacts		V AC 2,000 (48.52); 2,500 (48.12/62)			
Conducted disturbance immunity					
Burst (5...50)ns, 5 kHz, on A1 - A2		EN 61000-4-4		level 4 (4 kV)	
Surge (1.2/50 µs) on A1 - A2 (differential mode)		EN 61000-4-5		level 3 (2 kV)	
Other data					
Bounce time: NO/NC		ms 2/5; 2/10 (48.12)			
Vibration resistance (5...55)Hz: NO/NC		g 10/4 (for 1 pole)		15/3; 20/6 (48.12) for 2 pole	
Power lost to the environment	without contact current	W 0.7			
	with rated current	W 1.2 (48.12/31)	1.3 (48.52/72)	1.2 (48.61/62/81/82)	
Wire strip length		mm 8			
Screw torque		Nm 0.5			
Max. wire size	Screw terminal		Screwless terminal		
		solid cable	stranded cable	solid cable	stranded cable
	mm ²	1x6 / 2x2.5	1x4 / 2x2.5	2x(0.2...1.5)	2x(0.2...1.5)
	AWG	1x10 / 2x14	1x12 / 2x14	2x(24...18)	2x(24...18)