

MX2/RX PROFIBUS Option Board

Model: 3G3AX-MX2-PRT-E
3G3AX-RX-PRT-E

USER'S MANUAL



OMRON

Notice:

OMRON products are manufactured for use according to proper procedures by a qualified operator and only for the purposes described in this manual.

The following conventions are used to indicate and classify precautions in this manual. Always heed the information provided with them. Failure to heed precautions can result in injury to people or damage to property.

OMRON Product References

All OMRON products are capitalized in this manual. The word "Unit" is also capitalized when it refers to an OMRON product, regardless of whether or not it appears in the proper name of the product.

Trademarks and Copyrights

PROFIBUS, PROFIBUS FMS and PROFIBUS DP are trademarks of PROFIBUS International.

Other product names and company names in this manual are trademarks or registered trademarks of their respective companies.

The copyright of the Option Board Option Board belongs to OMRON Corporation.

Intended Audience

This manual is intended for the following personnel, who must also have knowledge of electrical systems (an electrical engineer or the equivalent).

- Personnel in charge of installing FA systems.
- Personnel in charge of designing FA systems.
- Personnel in charge of managing FA systems and facilities.
- Personnel in charge of maintaining FA systems.

About this Manual

This manual describes the:

- PROFIBUS 3G3AX-MX2-PRT-E Option Board for OMRON's MX2 Inverter.
- PROFIBUS 3G3AX-RX-PRT-E Option Board for OMRON's RX Inverter.

It also describes how to install and operate the Unit.

Please read this manual carefully so that you understand the information provided before installing or using the Option Board. Start with the Safety Messages on page ix. They describe the operating environment and application safety measures which must be observed prior to and when using the Option Board Option Board.

© OMRON, 2011

All rights reserved. No part of this publication may be reproduced, stored in a retrieval system, or transmitted, in any form, or by any means, mechanical, electronic, photocopying, recording, or otherwise, without the prior written permission of OMRON.

No patent liability is assumed with respect to the use of the information contained herein. Moreover, because OMRON is constantly striving to improve its high-quality products, the information contained in this manual is subject to change without notice. Every precaution has been taken in the preparation of this manual. Nevertheless, OMRON assumes no responsibility for errors or omissions. Neither is any liability assumed for damages resulting from the use of the information contained in this publication.

For the remainder of this manual, both the 3G3AX-MX2-PRT-E PROFIBUS Option Board as the 3G3AX-RX-PRT-E PROFIBUS Option Board will be referred as Option Board or Unit. The MX2 and RX Inverters will be referred as Inverter.

In case information is especially for the MX2 or for the RX Inverter, a clear notification will be included for which the note is meant.

If information especially is meant for the MX2, this symbol is shown: 

If information especially is meant for the RX, this symbol is shown: 

Please be sure to read the related user manuals to use the Option Board Option Board safely and properly. Be sure you are using the most current version of the manual:

Manual	Products	Contents	Cat No.
MX2 User's Manual	MX2 Inverter	Describes the installation and operation of the MX2 Inverter	I570
RX User's Manual	RX Inverter	Describes the installation and operation of the RX Inverter	I560
PROFIBUS Installation Guideline for Cabling and Assembly	PROFIBUS	Provides information on how to properly install PROFIBUS wiring and to provide practical guidance on the best ways to achieve this	PNO Order No. 8.022
PROFIBUS Profile for Variable Speed Drives	PROFIdrive	Provides information on the PROFIdrive device profile and it's usage	PNO Order No. 3.072
PROFIBUS Master Units	CS1W-PRM21 CJ1W-PRM21	Operation manual for PROFIBUS master units	W409

Warranty and Limitations of Liability

WARRANTY

OMRON's exclusive warranty is that the products are free from defects in materials and workmanship for a period of one year (or other period if specified) from date of sale by OMRON.

OMRON MAKES NO WARRANTY OR REPRESENTATION, EXPRESS OR IMPLIED, REGARDING NONINFRINGEMENT, MERCHANTABILITY, OR FITNESS FOR PARTICULAR PURPOSE OF THE PRODUCTS. ANY BUYER OR USER ACKNOWLEDGES THAT THE BUYER OR USER ALONE HAS DETERMINED THAT THE PRODUCTS WILL SUITABLY MEET THE REQUIREMENTS OF THEIR INTENDED USE. OMRON DISCLAIMS ALL OTHER WARRANTIES, EXPRESS OR IMPLIED.

LIMITATIONS OF LIABILITY

OMRON SHALL NOT BE RESPONSIBLE FOR SPECIAL, INDIRECT, OR CONSEQUENTIAL DAMAGES, LOSS OF PROFITS OR COMMERCIAL LOSS IN ANY WAY CONNECTED WITH THE PRODUCTS, WHETHER SUCH CLAIM IS BASED ON CONTRACT, WARRANTY, NEGLIGENCE, OR STRICT LIABILITY.

In no event shall the responsibility of OMRON for any act exceed the individual price of the product on which liability is asserted.

IN NO EVENT SHALL OMRON BE RESPONSIBLE FOR WARRANTY, REPAIR, OR OTHER CLAIMS REGARDING THE PRODUCTS UNLESS OMRON'S ANALYSIS CONFIRMS THAT THE PRODUCTS WERE PROPERLY HANDLED, STORED, INSTALLED, AND MAINTAINED AND NOT SUBJECT TO CONTAMINATION, ABUSE, MISUSE, OR INAPPROPRIATE MODIFICATION OR REPAIR.

Application Considerations

SUITABILITY FOR USE

OMRON shall not be responsible for conformity with any standards, codes, or regulations that apply to the combination of products in the customer's application or use of the products.

At the customer's request, OMRON will provide applicable third party certification documents identifying ratings and limitations of use that apply to the products. This information by itself is not sufficient for a complete determination of the suitability of the products in combination with the end product, machine, system, or other application or use.

The following are some examples of applications for which particular attention must be given. This is not intended to be an exhaustive list of all possible uses of the products, nor is it intended to imply that the uses listed may be suitable for the products:

- o Outdoor use, uses involving potential chemical contamination or electrical interference, or conditions or uses not described in this manual.
- o Nuclear energy control systems, combustion systems, railroad systems, aviation systems, medical equipment, amusement machines, vehicles, safety equipment, and installations subject to separate industry or government regulations.
- o Systems, machines, and equipment that could present a risk to life or property.

Please know and observe all prohibitions of use applicable to the products.

NEVER USE THE PRODUCTS FOR AN APPLICATION INVOLVING SERIOUS RISK TO LIFE OR PROPERTY WITHOUT ENSURING THAT THE SYSTEM AS A WHOLE HAS BEEN DESIGNED TO ADDRESS THE RISKS, AND THAT THE OMRON PRODUCTS ARE PROPERLY RATED AND INSTALLED FOR THE INTENDED USE WITHIN THE OVERALL EQUIPMENT OR SYSTEM.

Disclaimers

PROGRAMMABLE PRODUCTS

OMRON shall not be responsible for the user's programming of a programmable product, or any consequence thereof.

CHANGE IN SPECIFICATIONS

Product specifications and accessories may be changed at any time based on improvements and other reasons. It is our practice to change model numbers when published ratings or features are changed, or when significant construction changes are made. However, some specifications of the products may be changed without any notice. When in doubt, special model numbers may be assigned to fix or establish key specifications for your application on your request. Please consult with your OMRON representative at any time to confirm actual specifications of purchased products.

DIMENSIONS AND WEIGHTS

Dimensions and weights are nominal and are not to be used for manufacturing purposes, even when tolerances are shown.

PERFORMANCE DATA

Performance data given in this manual is provided as a guide for the user in determining suitability and does not constitute a warranty. It may represent the result of OMRON's test conditions, and the users must correlate it to actual application requirements. Actual performance is subject to the OMRON Warranty and Limitations of Liability.

ERRORS AND OMISSIONS

The information in this manual has been carefully checked and is believed to be accurate; however, no responsibility is assumed for clerical, typographical, or proof-reading errors, or omissions.

Table of contents

Notice:	ii
OMRON Product References	ii
Trademarks and Copyrights	ii
Intended Audience.	ii
About this Manual	ii
Warranty and Limitations of Liability	iv
Application Considerations	iv
Disclaimers	v
Safety Messages	ix
1 Hazardous High Voltage	ix
2 General Precautions - Read These First!	ix
3 Installation Precautions	xi
4 Configuration Precautions	xi
5 Application Precautions	xi
6 Operating Environment Precautions	xiii
7 Handling, Storage and Disposal	xiii
8 Compliance with EC Directives	xiii
SECTION 1	
Getting Started	1
1-1 Introduction	1
1-2 Option Board Specifications	3
1-3 Introduction to PROFIBUS	4
SECTION 2	
Option Board Mounting and Installation	7
2-1 Orientation to Option Board Features	7
2-2 Basic System Description	9
2-3 How to mount the Option Board on the Inverter	10
SECTION 3	
Configuring Drive Parameters and Option Board	23
3-1 Configuring the Option Board	23
3-2 Configuring the Network	26
SECTION 4	
Operations and Monitoring	29
4-1 Source Selection	30
4-2 Operating the Motor	31
4-3 Customising the Process Area	33
4-4 Faults and Trips	38
4-5 Accessing Parameters	39
4-6 Flexible Mode	52
4-7 Limitations Caused by Inverter Mode and Rating Selection	55
SECTION 5	
Troubleshooting and Maintenance	57
5-1 Troubleshooting using the LED indicators	57
5-2 Troubleshooting Using PROFIBUS Diagnostics	62
5-3 Maintenance and Inspection	65
5-4 Warranty	72

APPENDIX A	
Glossary	73
 APPENDIX B	
Parameter Process Data Object Modules	75
B-1 I/O Mapping	76
B-2 Control and Status Words - STW/ZSW	77
B-3 Frequency Reference and Output Frequency - HSW/HIW	77
B-4 Parameter Processing Message Area - PKW	78
 APPENDIX C	
Conventional Modules	79
C-1 Basic Data I/O Mapping	79
C-2 Extended Data 1 I/O Mapping	79
C-3 Extended Data 2 I/O Mapping	80
C-4 Operation Command and Inverter Status Registers	80
C-5 Extended Data 1 Digital Output Register	81
C-6 1 Digital Output Register	81
C-7 Modbus Message Area	82
 APPENDIX D	
Flexible Module	83
 APPENDIX E	
PROFIdrive DP-V1 Parameter Channel	85
E-1 Read Parameter Request	86
E-2 Read Parameter Response	87
E-3 Change Parameter Request	88
E-4 Change Parameter Response	89
E-5 Parameter Value Formats	90
 APPENDIX F	
Option Board Parameters	91
 APPENDIX G	
PROFIdrive Error Numbers	93
 APPENDIX H	
Slave_Diag Message (SAP60)	95
 Table index	 97
 Revision history	 100

Safety Messages

Read this manual and the warning labels attached to the Inverter carefully, before you start to install and operate the Inverter.

Please follow the instructions exactly.

Keep this manual handy for quick reference.

Definitions and Symbols

A safety instruction (message) includes a "Safety Alert Symbol" and a signal word or phrase such as WARNING or CAUTION. Each signal word has the following meaning:

 **HIGH VOLTAGE** Indicates a potentially hazardous situation which, if not avoided, could result in electric shock. It calls your attention to items or operations that could be dangerous to you and other persons operating this equipment.

Read the message and follow the instructions carefully.

 **WARNING** Indicates a potentially hazardous situation which, if not avoided, could result in death or serious injury. Additionally, there may be severe property damage.

 **Caution** Indicates a potentially hazardous situation, which, if not avoided, may result in minor or moderate injury, or property damage.

Step 1 Indicates a step in a series of action steps required to accomplish a goal. The number of the step will be contained in the step symbol.

Note Notes indicate an area or subject of special merit, emphasizing either the product's capability or common errors in operation or maintenance.

Tip Tips give a special instruction that can save time or provide other benefits while installing or using the product. The tip calls attention to an idea that may not be obvious if you are a first-time user of the product.

1 Hazardous High Voltage

 **HIGH VOLTAGE** Motor control equipment and electronic controllers are connected to hazardous line voltages. When servicing drives and electronic controllers, there may be exposed components with housing or protrusions at or above line potential. Extreme care should be taken to protect against shock. Stand on an insulating pad and make it a habit to use only one hand when checking components. Always work with another person in case an emergency occurs. Disconnect power before checking controllers or performing maintenance. Be sure equipment is properly grounded. Wear safety glasses whenever working on electronic controllers or rotating machinery.

2 General Precautions - Read These First!

 **WARNING** Failure to read and understand the information provided in this manual may result in personal injury or death, damage to the product, or product failure. Please read each section in its entirety and be sure you understand the information provided in the section and related sections before attempting any of the procedures or operations given.

General Precautions - Read These First!

-  **WARNING** This equipment should be installed, adjusted, and serviced by qualified electrical maintenance personnel familiar with the construction and operation of the equipment and the hazards involved. Failure to observe this precaution could result in bodily injury.
-  **WARNING** Wiring, maintenance or inspection must be performed by authorized personnel. Not doing so may result in electrical shock or fire.
-  **WARNING** Hazard of electrical shock! Disconnect incoming power before working on the Option Board or the Inverter!
-  **HIGH VOLTAGE** Turn the power supply OFF and wait for the time specified on the Option Board front cover before performing wiring, maintenance or inspection. Not doing so may result in electrical shock.
- The Option Board is attached to an Inverter.
Dangerous voltage exists until the Inverter power light is OFF.
-  **HIGH VOLTAGE** Do not touch the conductive parts such as the internal PCB, terminals or connector while power is being supplied. Doing so may result in electrical shock.
-  **WARNING** Do not attempt to take an Option Board apart or touch any internal parts while the power is being supplied. Doing so may result in electric shock.
-  **WARNING** Do not attempt to disassemble, repair, or modify an Option Board. Any attempt to do so may result in malfunction, fire, or electric shock.
-  **WARNING** Provide emergency stop circuits, interlock circuits, limit circuits and similar safety measures in external circuits (NOT in the Option Board). This ensures safety in the system if an abnormality occurs due to malfunction of the Option Board or another external factor affecting the Option Board operation. Not doing so may result in serious accidents.
-  **WARNING** Fail-safe measures must be taken by the customer to ensure safety in the event of incorrect, missing, or abnormal signals caused by broken signal lines, momentary power interruptions, or other causes. Not doing so may result in serious accidents.
-  **Caution** Do not touch the Inverter during power on, and immediately after power off. Hot surface may cause injury.
-  **Caution** The product will be used to control an adjustable speed drive connected to high voltage sources and rotating machinery that is inherently dangerous if not operated safely. Interlock all energy sources, hazardous locations, and guards in order to restrict the exposure of personnel to hazards. The adjustable speed drive may start the motor without warning. Signs on the equipment installation must be posted to this effect. A familiarity with auto-restart settings is a requirement when controlling adjustable speed drives. Failure of external or ancillary components may cause intermittent system operation, i.e., the system may start the motor without warning or may not stop on command. Improperly designed or improperly installed system interlocks and permissives may render a motor unable to start or stop on command.

3 Installation Precautions

 **WARNING** Always connect the grounding cable to one of the ground terminals of the Inverter. Failure to abide could lead to serious or possibly fatal injury.

 **Caution** Failure to observe these precautions could lead to faulty operation of the Option Board or the Inverter, or could damage either of the two. Always read these precautions.

- Install external breakers and take other safety measures against short-circuits in external wiring. Not observing this may result in burning.
- Be sure that all cable connector screws are tightened to the torque specified in the relevant manuals. Incorrect tightening torque may result in malfunction.
- Do not allow metal clippings to enter either Option Board or Inverter when wiring or installing the unit.
- Follow "PROFIBUS Installation Guideline for Cabling and Assembly" (PNO Order No. 8.022)
 - Wire the PROFIBUS cables and connectors correctly. Incorrect wiring may result in burning.
 - Apply termination at both ends of a PROFIBUS cable segment. Do not apply termination anywhere else.
- Be sure that the Option Board is mounted correctly. Improper mounting may result in malfunction.
- Disconnect the grounding cable when performing withstand-voltage tests. Not disconnecting the grounding cable may result in burning.

4 Configuration Precautions

 **Caution** Failure to observe these precautions could lead to unexpected operation of the Option Board or the Inverter. Always read these precautions.

- Check the network related Inverter settings regarding PROFIBUS node address and PROFIBUS map selection. Not doing so may result in unexpected operation.
- When replacing an Inverter be sure that all Inverter settings of the Inverter being replaced are restored to the replacement.
- Restoring parameters stored in the remote operator also restores the PROFIBUS node address. Always check the node address and other network related Inverter settings after restore.

5 Application Precautions

 **WARNING** Before using the product under conditions which are not described in the manual or applying the product to nuclear control systems, railroad systems, aviation systems, vehicles, combustion systems, medical equipment, amusement machines, safety equipment, and other systems, machines, and equipment that may have a serious influence on lives and property if used improperly, consult your OMRON representative.

 **WARNING** It is extremely important that the Unit is used for its specified purpose and under the specified conditions, especially in applications that can directly or indirectly affect human life. You must consult your OMRON representative before using it in a system in the above-mentioned applications.

Application Precautions

 **WARNING** Failure to observe these precautions could lead to serious or possibly fatal injury. Always read these precautions.

- Check any user program in the system that acts as a PROFIBUS master before actually running it. Not checking the program may result in unexpected operation.

MX2

- A revision AAAA Inverter allows the motor to run immediately if a trip condition is reset, and at the same time, a run command is active via PROFIBUS. For safe operation clear the run command via PROFIBUS as soon as a trip condition is detected. Refer to section 1-1-2 *Inverter Support* to determine the Inverter revision.

 **Caution** Failure to observe these precautions could lead to faulty operation of the Option Board or the Inverter, or could damage to either of the two. Always read these precautions.

- Check the Inverter settings for proper Inverter behavior before actually operating the Inverter remotely via the PROFIBUS network.
- Check the Inverter's EzSQ program and its interaction with the PROFIBUS master before actually running it on the Inverter. Not checking the program may result in unexpected operation.
- Confirm that no adverse effect will occur at the moment the PROFIBUS master stops communicating with the Inverter or at the moment the PROFIBUS master has not yet started communicating to the Inverter.
- Confirm that no adverse effect will occur in the Inverter before force-setting/force-resetting any bit in the system that acts as a PROFIBUS master.

6 Operating Environment Precautions

-  **Caution** Do not operate the Inverter with a mounted Option Board in the following locations (doing so may result in malfunction, electric shock or burning):
- Locations subject to direct sunlight
 - Locations subject to temperatures or humidity outside the range specified in the specifications
 - Locations subject to condensation as the result of severe changes in temperature
 - Locations subject to corrosive or flammable gases
 - Locations subject to dust (especially iron dust) or salts
 - Locations subject to exposure to water, oil, or chemicals
 - Locations subject to shock or vibration
-  **Caution** Take appropriate and sufficient countermeasures when installing systems in the following locations (doing so may result in malfunction):
- Locations subject to static electricity or other forms of noise
 - Locations subject to strong electromagnetic fields
 - Locations subject to possible exposure to radioactivity
 - Locations close to power supplies
-  **Caution** The operating environment of the Inverter with a mounted Option Board can have a large effect on the longevity and reliability of the system. Improper operating environments can lead to malfunction, failure, and other unforeseeable problems with the system. Make sure that the operating environment is within the specified conditions at installation and remains within the specified conditions during the life of the system.

7 Handling, Storage and Disposal

-  **Caution** Failure to observe these precautions could lead to faulty operation of- or damage to the Option Board. Always read these precautions.
- Before touching the Option Board or Inverter, be sure to first touch a grounded metallic object in order to discharge any static built-up. Not doing so may result in malfunction or damage.
 - When transporting or storing the Option Board keep the product within the specified storage temperature range.
-  **Caution** Never dispose electrical components by incineration. Contact your state environmental agency for details on disposal of electrical components and packaging in your area.

8 Compliance with EC Directives

This product complies with EC Directives when mounted to an Inverter with the grounding cable connected.

SECTION 1

Getting Started

1-1 Introduction

1-1-1 Main Features

The Option Board 3G3AX-MX2-PRT-E and the 3G3AX-RX-PRT-E allow controlling, monitoring and parameterization of an Inverter via a PROFIBUS network.

The Option Board serves as a gateway that passes communicated register values from the PROFIBUS network to the Inverter and vice versa.

The following functions are available via PROFIBUS communication by installing the Option Board:

Cyclic Data Exchange

The PROFIBUS Master and Option Board can exchange data via a PROFIBUS DP-V0 message connection:

- Output data (from PROFIBUS Master to Option Board):
E.g. Run/stop, Reference frequency and Fault reset
- Input data (from Option Board to PROFIBUS Master):
E.g. Inverter status, Output frequency and Output current

Inverter Parameter Access

The PROFIBUS Master can read and write parameter data via the Option Board using the mailboxes provided by some modules, as well as a PROFIdrive DP-V1 parameter channel.

Simplified Start-up

The Option Board can be set up easily, just by wiring the Unit, setting the PROFIBUS node address (P180) and device profile (P182) and restarting the unit. The Unit's configuration is read automatically when the power is turned ON. It is not necessary to make any settings with a special Programming Device.

Simplified Replacement

All parameters required by the Option Board are stored in the Inverter. The Option Board can be replaced, requiring no re-configuration.

Automatic Baud Rate Recognition

The Option Board automatically detects the Master's communication baud rate, and no user configuration is required.

Note The PROFIdrive DP-V1 parameter channel is only available if the PROFIBUS Master also provides DP-V1 Class 2 (MSAC2) Messaging to the user.

Note If the PROFIBUS Master's baud rate changes, the PROFIBUS Communication Unit must be turned OFF and then ON to detect the new baud rate.

1-1-2 Inverter Support

1-1-2-1 Inverter support for the MX2

MX2 The 3G3AX-MX2-PRT-E Option Board supports the MX2 Inverter with minimum revision of AAAA. An MX2 Inverter that supports the 3G3AX-MX2-PRT-E Option Board can be recognized from the Inverter type label. Please check that your Inverter type label displays revision characters in the bottom right corner where the is displayed in this illustration.



Please note if these characters are absent, your Inverter does not support the 3G3AX-MX2-PRT-E, so please contact your local OMRON representative.

1-1-2-2 Inverter support for the RX

RX The 3G3AX-RX-PRT-E Option Board supports the RX Inverter with minimum revision of RX-□-E1F or RX-□-V1. An RX Inverter that supports the 3G3AX-RX-PRT-E Option Board can be recognized from the Inverter type label.

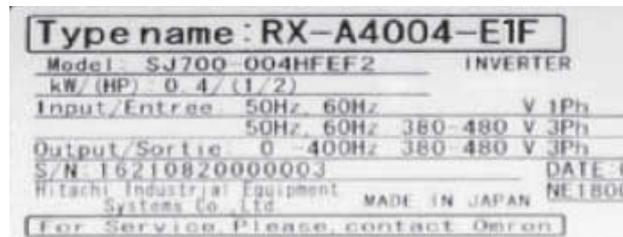

Note If your RX Inverter has no postfix on type label (e.g. RX-A4004) or the EF postfix (e.g. RX-A4004-EF) the 3G3AX-RX-PRT-E option is not supported, so please contact your local OMRON representative.

1-1-3 Inverter Safety (ISO 13849-1)

MX2 An Inverter provides a Gate Suppress function to perform a safe stop according to the EN60204-1, stop category 0. The Option Board has been designed not to interfere with this safety function.

The Option Board is not a safety device and does not implement any safety protocols.

Note The Option Board is not a safety device and does not implement any safety protocols such as PROFIsafe.

1-2 Option Board Specifications

Table 1 Option Board Specifications

Item		Specification
MX2 Installation MX2	Unit type	MX2 Series Option Card
	Model	Option Board
	Dimensions (W x H x D)	68 x 58 x 45 mm
	Weight	170g (typical)
RX Installation RX	Unit type	RX Series Option Card
	Model	3G3AX-RX-PRT-E
	Dimensions (W x H x D)	80 x 67 x 49 mm
	Weight	170gram (typical)
Environment	Ambient operating temperature*1	-10 to 55°C (no icing or condensation)
	Ambient operating humidity	20 to 90%RH
	Ambient storage temperature	-20 to 65°C (no icing or condensation)
	Vibration resistance	5.9m/s ² (0.6G) at 10...55Hz
	Dielectric strength	500 VAC (between isolated circuits)
	Conformance to EMC and Electrical safety standards	EN61800-3: 2004 (2004/108/EC) Second environment, Category C3
		EN61800-5-1: 2007 (2006/95/EC) SELV
Enclosure rating	IP 20	
Front Case	Indicators	4 LEDs, indicating Option Board and PROFIBUS status: Option Board Status: RUN (Green) ERR(Red) PROFIBUS Status: BF (Red) COMM (Green)
	PROFIBUS connector	9-pin sub-D female connector (#4/40 UNC thread)
PROFIBUS Interface	Applicable standards	IEC 61158 Industrial communication networks - Fieldbus specifications
	Protocol type supported	PROFIBUS DP
		PROFIBUS DP-V1, Class 2 (MSAC2 acyclic messaging)
	PROFIBUS Unit type	PROFIBUS DP-V1 Slave
	PROFIBUS Media type	RS-485, galvanically isolated from the Inverter
	PROFIBUS Connector	9-pin sub-D female connector (#4/40 UNC thread)
		Termination according to EN50170 provided by the cable connector
	Certificate	Test Specification for PROFIBUS DP Slaves, Version 3.0 DP-V0 DP-V1 Physical Layer
	Unit device address range	0 ~ 125, set with inverter parameter P180
Baud rates supported	Automatically detected from: 9.6 kbit/s 19.2 kbit/s 45.45 kbit/s 93.75 kbit/s 187.5 kbit/s 500 kbit/s 1.5 Mbit/s 3 Mbit/s 6 Mbit/s 12 Mbit/s	

Note 1 The derated- or ambient operating temperature of the Inverter takes precedence over that of the Option Board.

Table 1 Option Board Specifications (continued)

Item		Specification				
PROFIBUS DP Services and Profiles	Master Class 1 – Slave cyclic services	Set_Prm Get_Cfg	Chk_Cfg Rd_Inp	Slave_Diag Rd_Outp	Data_Exchange	
		Global-Control (SYNC/UNSYNC, FREEZE/UNFREEZE & CLEAR)				
	Master Class 1 – Slave acyclic services	Not supported				
	Master Class 2 – Slave acyclic services	MSAC2_Initiate	MSAC2_Read	MSAC2_Write	MSAC2_Abort	
	Profiles supported	PROFIdrive V2	(If P182 = 0)			
		Conventional	(If P182 = 1)			
		Flexible	(If P182 = 2)			
	Supported I/O modules	PROFIdrive V2 (If P182 = 0)	PPO Type 1 (4 words PKW + 2 words PZD)			
			PPO Type 2 (4 words PKW + 6 words PZD)			
			PPO Type 3 (2 words PZD)			
			PPO Type 4 (6 words PZD)			
			PPO Type 5 (4 words PKW + 10 words PZD)			
Conventional (If P182 = 1)		Basic Data				
		Extended Data 1 Extended Data 2				
Flexible (If P182 = 2)	Flexible (10 words output and input)					
I/O Data	I/O data	28 bytes max. input data using PPO Type 5				
		28 bytes max. output data using PPO Type 5				
	Diagnostics data size	11 bytes				
MX2	MX2 GSD file	OC_0C6A.gsd				
RX	RX GSD file	OC_0D2F.gsd				

1-3 Introduction to PROFIBUS

1-3-1 The Purpose of PROFIBUS

PROFIBUS (PROcess FieldBUS) is an open fieldbus standard for a wide range of applications in manufacturing, processing and building automation. The Standard, IEC 61158 (Industrial communication networks), to which PROFIBUS adheres, guarantees vendor independence and transparency of operation. It enables devices of various manufacturers to intercommunicate without having to make any special interface adaptations.

1-3-2 What is PROFIBUS DP

PROFIBUS DP (for Decentralized Periphery) is a variant optimized for high speed and low-cost interfacing. It is specially designed for communication between automation control systems and distributed I/O at the device level.

PROFIBUS DP uses the same transmission technology and uniform bus access protocol as PROFIBUS FMS (for Fieldbus Message Specification). Consequently, both versions can be operated simultaneously on the same bus. DP field devices, however, cannot be controlled by FMS masters and vice versa.

 **Caution** It is not possible to exchange a PROFIBUS DP device or master for a PROFIBUS FMS device or master. This will cause faulty operation.

1-3-3 What is PROFdrive

The PROFdrive device profile supplements the PROFIBUS standard. It defines a unified behavior and technique to access Inverter and drive device data. All drives supporting the PROFdrive profile respond the same way to control instructions.

 **Caution** For backward compatibility and direct use of the Inverter registers, the Option Board offers two additional device profiles that are NOT PROFdrive compliant. For PROFdrive compliance, ensure that P182 = 0.

SECTION 2 Option Board Mounting and Installation

2-1 Orientation to Option Board Features

2-1-1 Unpacking and Inspection

Take a few moments to unpack your new Option Board and perform these steps:

1. Look for any damage that may have occurred during transportation.
2. Verify the contents of the box
3. Inspect the markings on the Option Board. Make sure it matches the product part number you ordered:

MX2

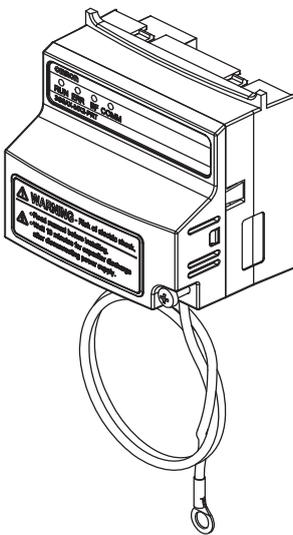

Option Board with Grounding

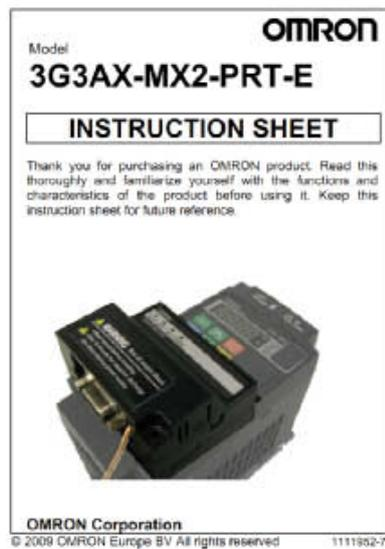

Instruction Sheet



Warning Labels

RX

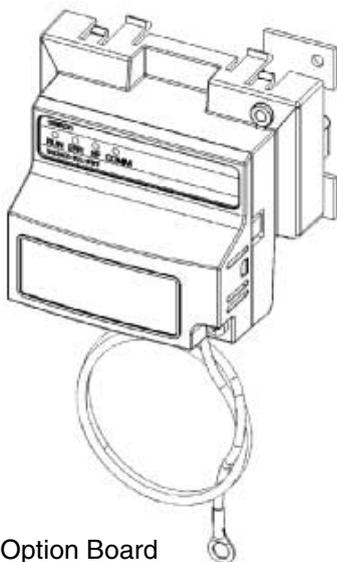

Option Board with Grounding Cable and Profibus connector



Instruction Sheet

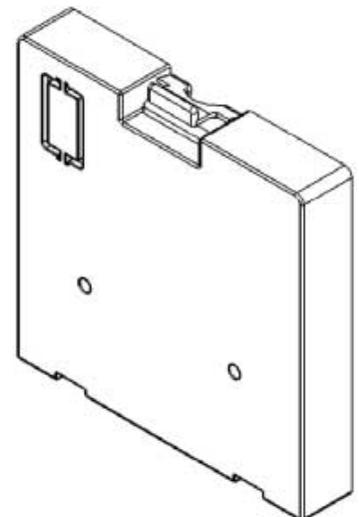

Blind cover

2-1-2 Main Physical Features

MX2

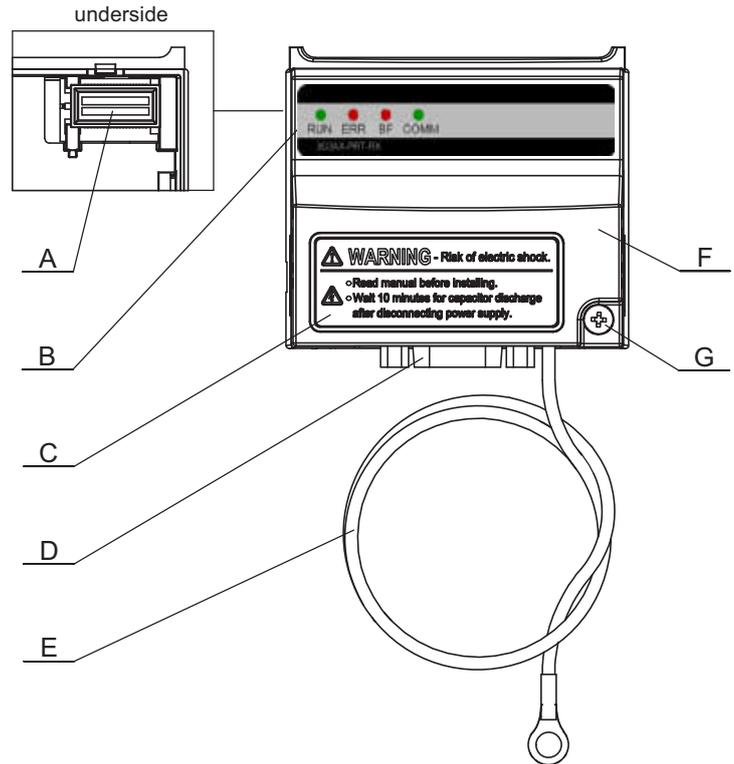

- A - Option board connector
- B - LED indicators (RUN, ERR, BF, COMM)
- C - Warning label
- D - Fieldbus connector
- E - Grounding cable
- F - Housing
- G - Mounting screw

RX

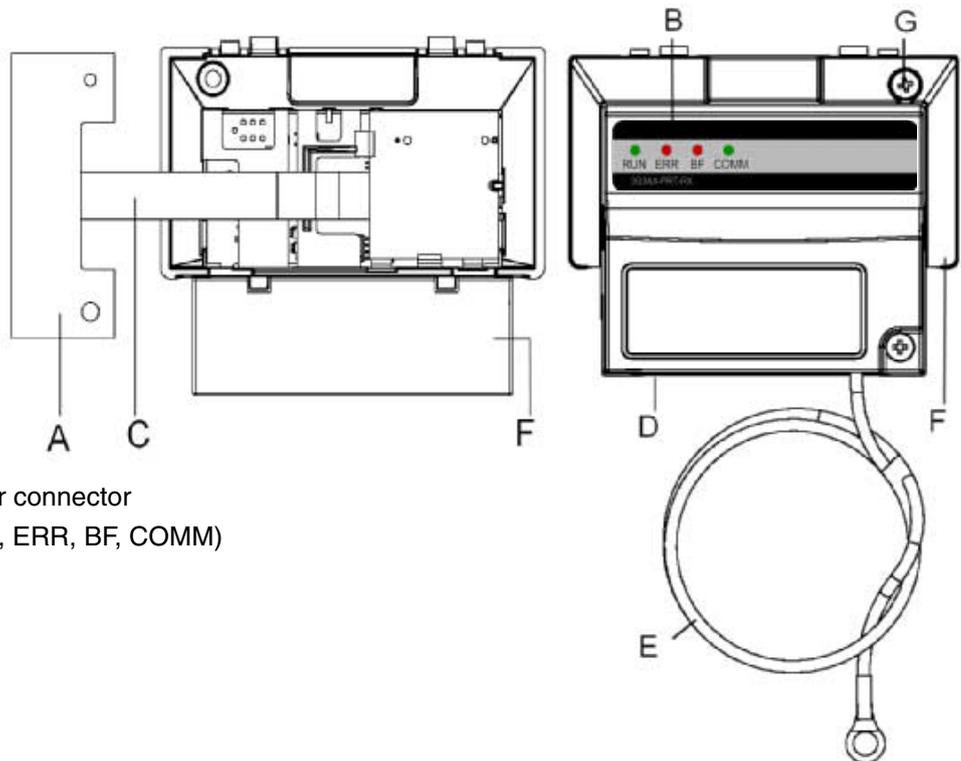

- A - Option Board Inverter connector
- B - LED indicators (RUN, ERR, BF, COMM)
- C - Option Board Cable
- D - Fieldbus connector
- E - Grounding cable
- F - Housing
- G - Mounting screw

Four LED indicators (B) allow easy diagnosis. An attached grounding cable (E) is sized to reach the ground terminals on all Inverter models. A feature in the housing (F) will retain the mounting screw (G) when the Option Board is not mounted to the Inverter. The orientation of the Fieldbus connector (D) allows unstrained connection and removal of the PROFIBUS connector. Please pay special attention to the Option Board connector: It must be properly connected with the Inverter when the Option Board is mounted.

2-1-3 LED Indicators

The LED indicators on the front indicate the operational mode and status of the Option Board and the network.

Table 2 LED Indicators

Indicator	Colour	Status	Meaning
RUN (Unit status)	Green	OFF	No power or not yet ready for operation
		Flashing	Operating in commissioning mode
		ON	Normal operation
ERR (Unit error)	Red	ON	Fatal error
		Flashing	Operational error
		OFF	No error
BF (Bus Fail)	Red	ON	No communication with PROFIBUS Master
		Flashing	Unsupported parameters or module configuration received from PROFIBUS Master
		OFF	Communicating with PROFIBUS Master
COMM (Comms status)	Green	ON	Cyclic data exchange or PROFIBUS diagnostics operational
		OFF	No cyclic data exchange or PROFIBUS diagnostics

Refer to *Section 5-1* for Troubleshooting using the LED indicators on page 57

2-2 Basic System Description

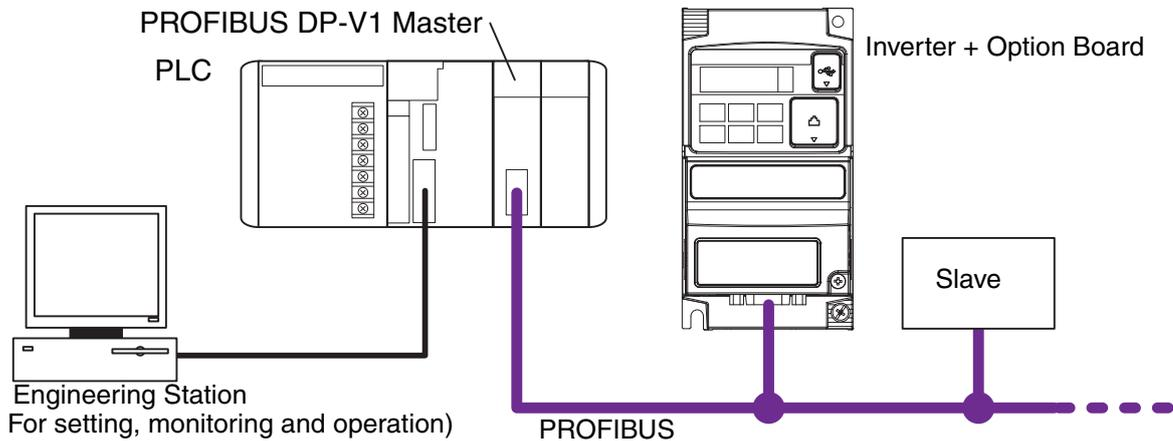

The Option Board connects to the Master via a PROFIBUS network cable. Inverter I/O data is generally shared with the Master's I/O memory through the PROFIBUS DP network. Every PROFIBUS communication cycle, Inverter I/O data is collected by the Option Board and exchanged with the Master. The Engineering Station allows you to configure, monitor, program, diagnose and operate the system.

2-3 How to mount the Option Board on the Inverter

 **HIGH VOLTAGE** Always Switch OFF the mains power supply to the Inverter before removing any covers. Wait for the time specified on the Inverter front cover for the capacitors to discharge. Not doing so may result in electrical shock.

 **HIGH VOLTAGE** Never operate the Inverter with the terminal block cover or backing plate removed.

 **WARNING** Provide emergency stop circuits, interlock circuits, limit circuits and similar safety measures in external circuits (NOT in the Option Board). This ensures safety in the system if an abnormality occurs due to malfunction of the Option Board or another external factor affecting the Option Board operation. Not doing so may result in serious accidents.

 **WARNING** Always connect the grounding cable to one of the ground terminals of the Inverter. Failure to abide could lead to serious or possibly fatal injury.

 **Caution** Never touch the heat sink during or just after operation; it can be very hot.

 **Caution** Be sure that the Option Board is mounted correctly. Improper mounting may result in malfunction.

 **Caution** Be sure that all cable connector screws are tightened to the torque specified in the relevant manuals. Incorrect tightening torque may result in malfunction.

Note Illustrations are only provided for one Inverter size. The instructions however are generic, and may be followed for all Inverter sizes.

 **MX2** Please refer to the MX2 Inverter manual (Cat. No. I570) section 2-1-3 for details on assembly and disassembly of the Inverter.

 **RX** Please refer to the RX Inverter manual (Cat. No. I560) section 2 for details on assembly and disassembly of the Inverter.

2-3-1 Mounting sequence of the Option Board on the MX2 Inverter

Step 1 **MX2** Loosen the screw of the option board cover, remove the cover and put the cover aside.

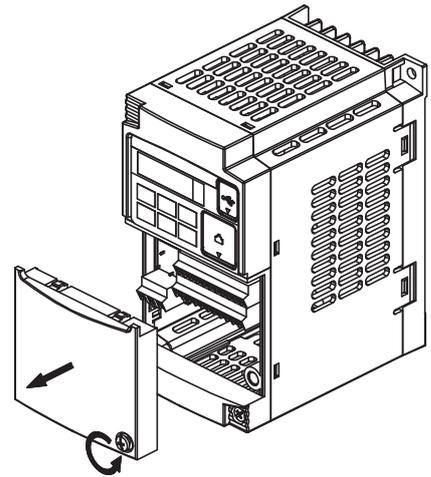

Step 2 **MX2** For Inverters up to 4.0 kW only: loosen the screws of the terminal block cover and remove the cover to enable access to the chassis ground terminal screws.

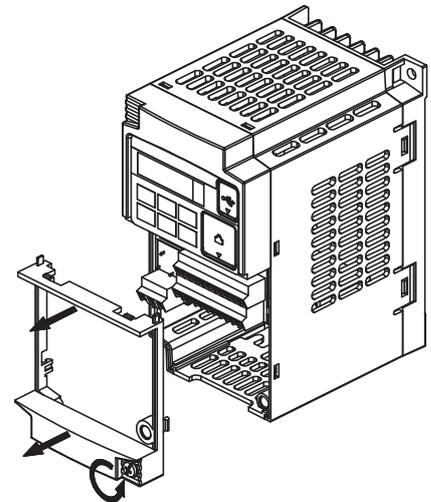

Step 3 **MX2** Secure the Option Board grounding cable to the Inverter with a mounting screw.

1-phase 200 V 0.1 - 2.2 kW
 3-phase 200 V 0.1 - 3.7 kW
 3-phase 400 V 0.4 - 4.0 kW

3-phase 200 V 5.5 - 15 kW
 3-phase 400 V 5.5 - 15 kW

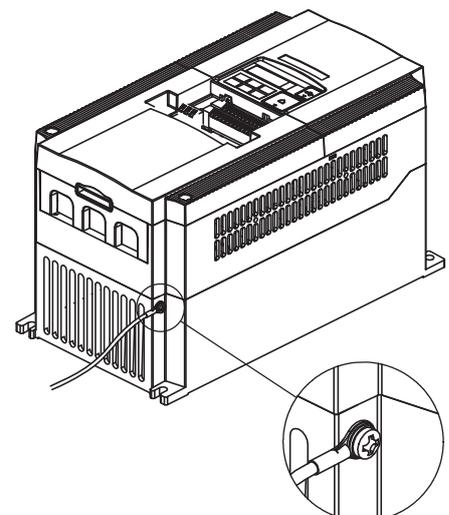
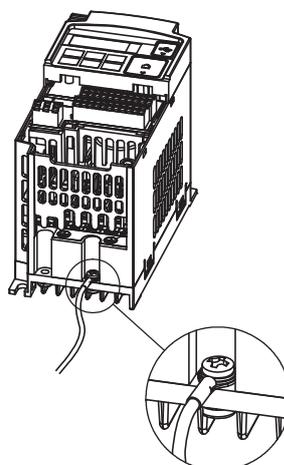

Step 4

MX2

If removed in Step 2, mount the terminal cover again and tighten the screw(s).

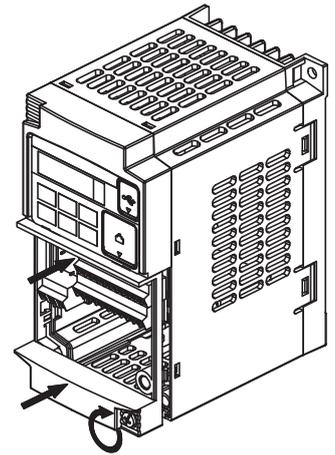

Step 5

MX2

Push the Option Board into the previous location of the option board cover until it clicks into place

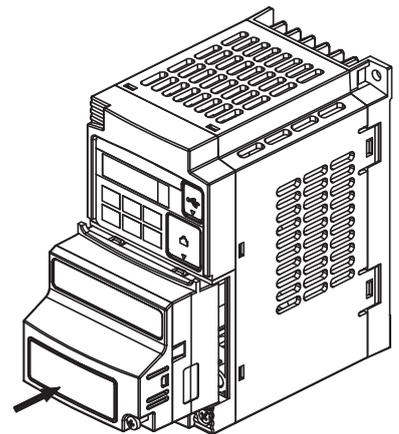

Step 6

MX2

Press down on the indicated corner of the Option Board housing to ensure proper connection of the Option Board connector

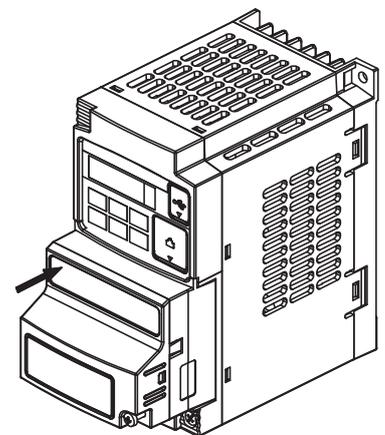

Step 7

MX2

Check that there is no gap between the top edges of the Option Board and the Inverter casing.

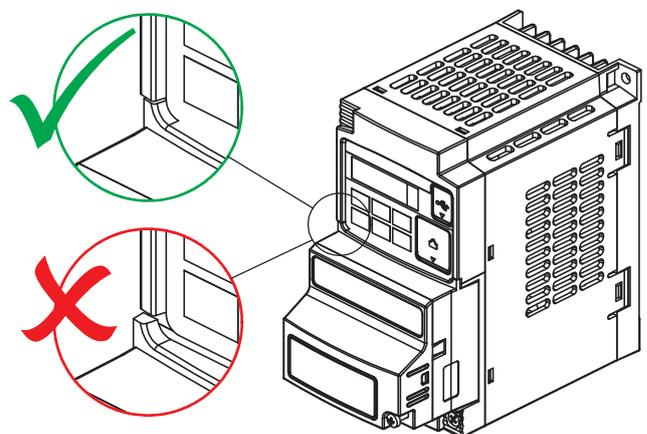

Step 8

MX2

Secure the Option Board in place with the mounting screw (do not over-tighten).

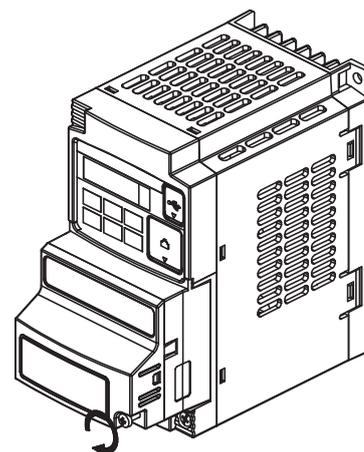

Step 9

MX2

Select the right warning language from the warning label sheet and replace the English warning if appropriate.

Note Refer to section 2-1-3 in the MX2 user's manual (Cat.-No. I570) for operations related to assembly and disassembly of the Inverter

Note Some Inverter models do not include a screw for the grounding cable. Please supply the recommended screw, lock-washer and washer to attach the grounding cable

Table 3 Ground cable screw selection

Inverter models	Grounding Cable Attachment Screw
3-phase 200 V 5.5 – 7.5 kW	M4 x 6
3-phase 400 V 5.5 – 7.5 kW	
3-phase 200 V 11 – 15 kW	M5 x 6
3-phase 400 V 11 – 15 kW	

2-3-2 How to install the Option Board on the RX Inverter

2-3-2-1 Preparation

RX When the Option Board is mounted on the RX Inverter, the Digital Operator Display can not be directly connected back on the RX Inverter. There are two solutions:

Commissioning with Digital Operator Display

This option is recommended, however it does require a straight Ethernet cable.

- Step 1** **RX** Mount the Option Board according paragraph 2-3-2-2 *Mounting sequence of the Option Board on the RX Inverter on page 14*.
- Step 2** **RX** Connect the Digital Operator Display using the 3G3AX CAJOP300-EE cable or straight Ethernet cable.
- Step 3** **RX** Set the desired parameters of the RX Inverter with the Digital Operator Display.

Commissioning via Profibus

- Step 1** **RX** Configure the essential Profibus communication parameters before mounting the Option Board. See also paragraph 3-2 *Configuring the Network on page 26*:
 - *Step 1* on page 23: Set the Device Profile using parameter P182.
 - *Step 3* on page 23: Set the Inverter parameter P180 PROFIBUS Node Address.
- Step 2** **RX** Mount the Option Board according paragraph 2-3-2-2 *Mounting sequence of the Option Board on the RX Inverter on page 14*. Set the desired parameters of the Inverter (Also referenced in this paragraph).
- Step 3** **RX** Configure the Inverter without Digital Operator:
 - Use the OMRON CX-Drive tool, or
 - Use PROFIdrive DP-V1 Parameter Channel to access the parameters directly (refer to *APPENDIX E PROFIdrive DP-V1 Parameter Channel*).

2-3-2-2 Mounting sequence of the Option Board on the RX Inverter

- Step 1** **RX** Remove from the RX Inverter:
 1. Digital Operator Display
 2. Terminal cover
 3. Front Cover
 4. Operator connector.

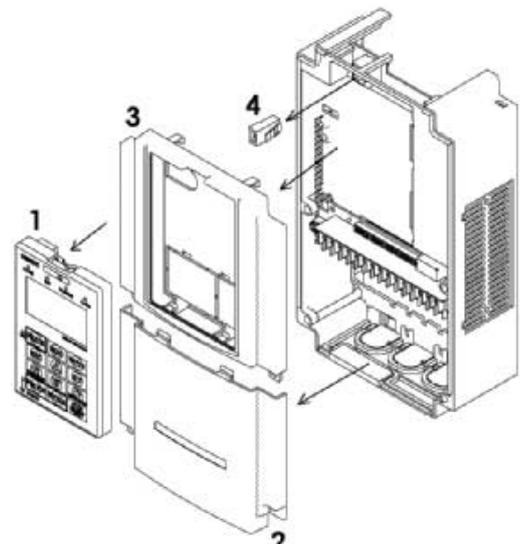

Step 2

RX Cut out the 2 plastic break-outs from the Front Cover.
 Make sure no sharp edges remain.

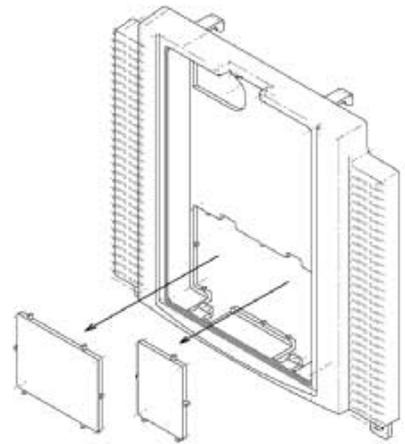

Step 3

RX Remount the Front Cover and tighten the screws

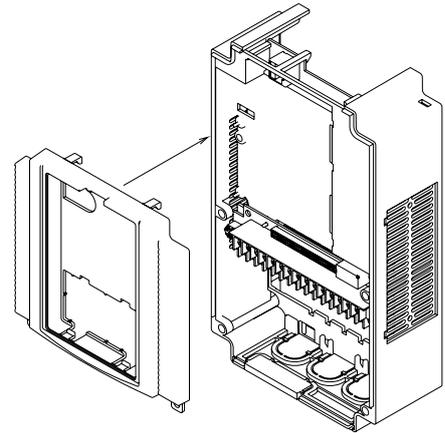

Step 4

RX Purpose: mount the Inverter Connector (no.1) of the Option Board onto the interface connector (no.5) of the RX Inverter.

How to do:

First align the small hole of the Inverter connector (no.2) with the guide-post (no.4) in the Inverter.

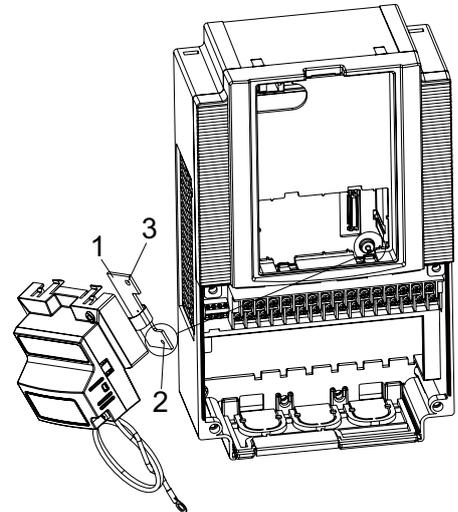

Then align the larger hole on the Inverter connector (no.3) with the threaded hole (no.6) in the Inverter.

Push the Inverter connector into place.

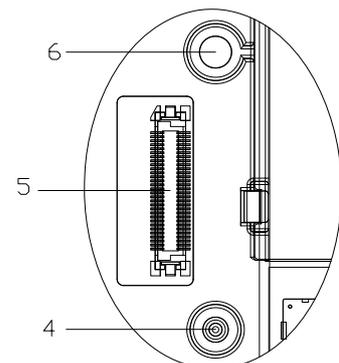

Step 5

RX Move the Option Board Cable (no.2) to the left with your finger, so the Option Board Cable is not pinched between the Option Board and the Inverter Front Cover.

Note Prevent a pinched Option Board Cable, as shown in position A.

Note Do not pull on the Option Board Cable.

Note Do not let the Option Board hang on the Option Board Cable.

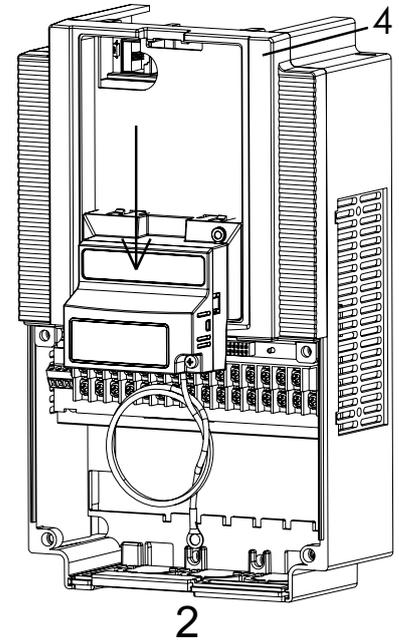
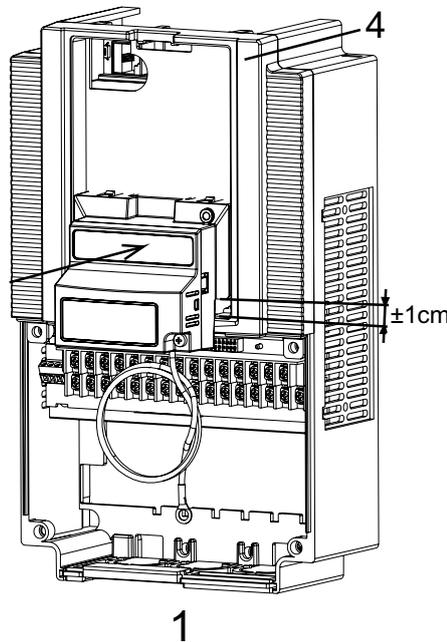
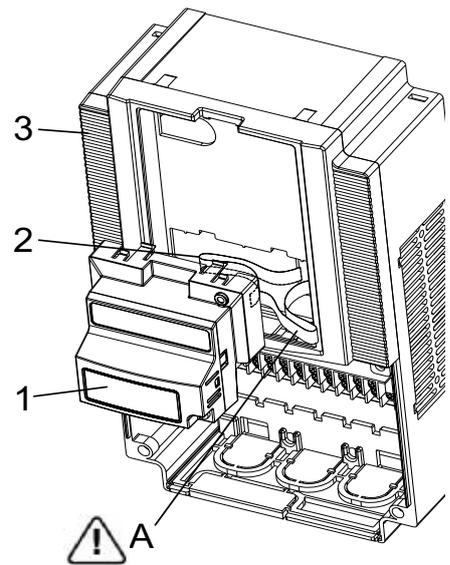

Insert the Option Board approximately 1 cm above the down-position into the Front cover of the Inverter. See figure 1 above.

Slide the Option Board down. See figure 2 above.

The snap-fits of the Option Board (no.5) will be locked by the snap-fits in the Front cover (no.4).

Option Board bottom side

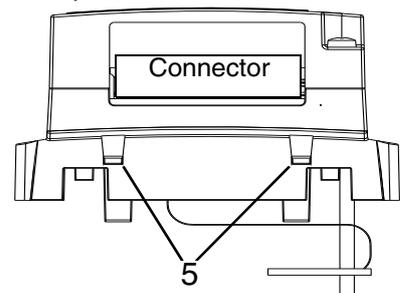

Step 6

RX Press down carefully the two locking pins (no. 1) of the Option Board.

Press carefully the top of the Option Board in the Inverter.

Check the Option Board is being locked by the locking pins (no.1).

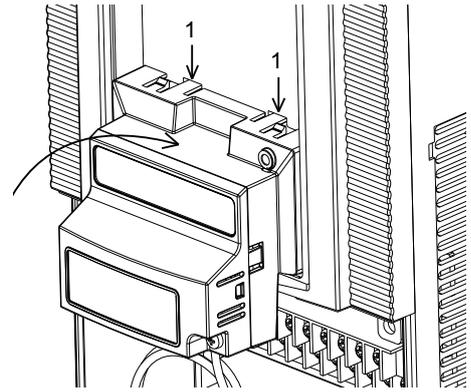

Step 7

RX Insert the screw (no. 1) into the upper right hole in the Option Board (no.2).

Tighten the screw into place (do not over tighten).

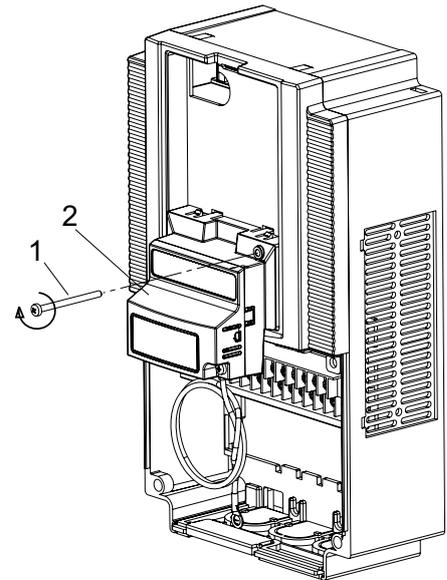

RX Fix the Option Board grounding cable to the chassis ground of the RX-Inverter under an already fixed chassis grounding bolt.

See the bold with the grounding figure.

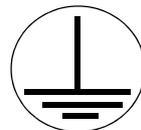

The position of the chassis ground vary from inverter type. Illustrations are only provided for one Inverter size. The instructions however are generic and may be followed for all Inverter sizes.

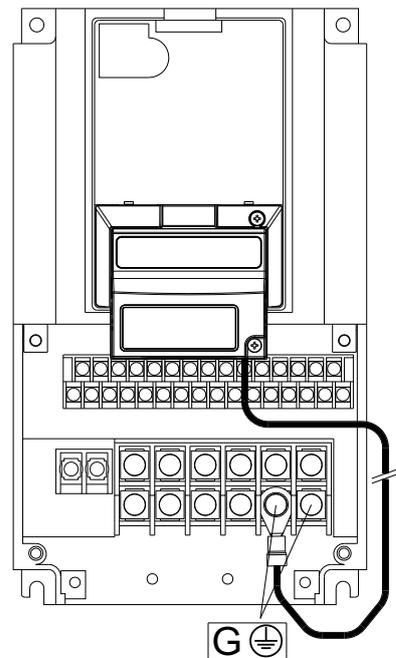

Step 8

RX Unscrew the mounting screws of the Terminal cover nearly completely from the plastic rings (no.1).

Remount the Terminal cover under the Option Board onto the Inverter (no.2).

Tighten the two screws (no.1).

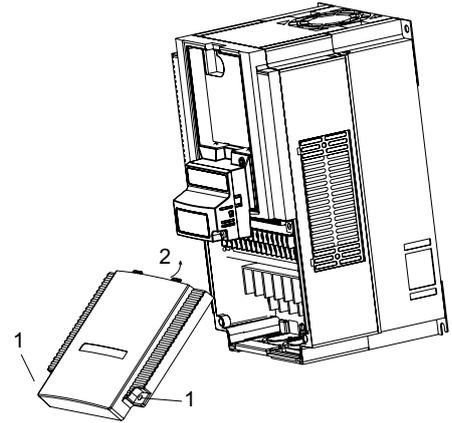

Step 9

RX Connect the Digital Operator Display via a 3G3AX CAJOP300-EE cable or via a straight EtherNet cable with the RJ45 connector in the Inverter.

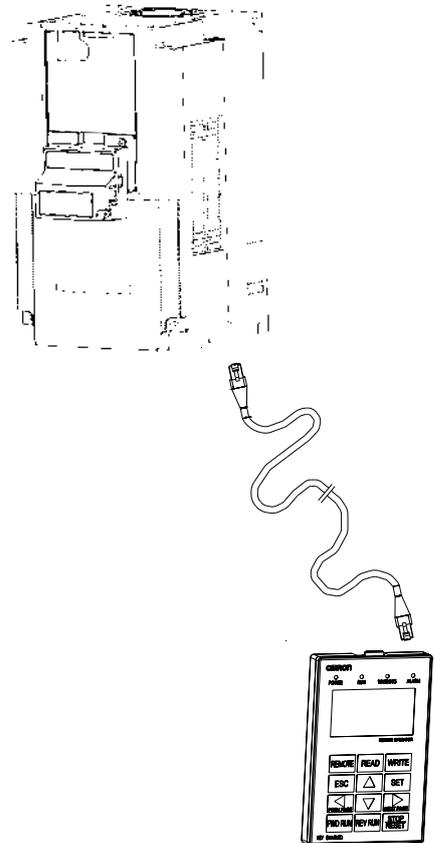

Step 10

RX Define needed and desired parameters of the Inverter and set them according *SECTION 3 Configuring Drive Parameters and Option Board on page 23* and also according *SECTION 4 Operations and Monitoring on page 29*.

Step 11

RX If the desired parameters of the Inverter have been set successfully, disconnect the 3G3AX CAJOP300-EE cable or straight EtherNet cable from the Inverter.

Push the blind cover (no.1) into place.

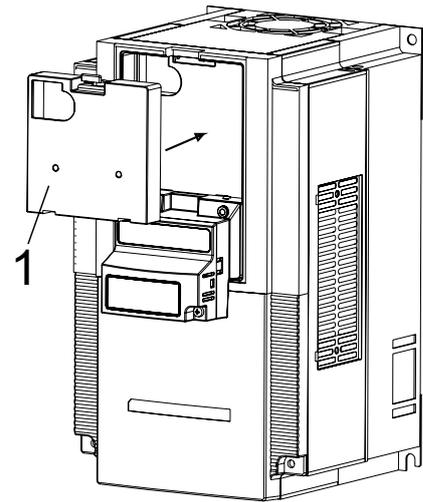

Note Refer to section 2 in the RX User's Manual (Cat. No. I560) for operations related to assembly and disassembly of the RX Inverter.

2-3-3 Installation Environment Clearance

Please adhere to the requirements of the Inverter for Installation Environment clearance.

MX2 Please refer to the MX2 Inverter manual (Cat. No. I570) section 2-3-2.

RX Please refer to the RX Inverter manual (Cat. No. I560) section 2-1 Installation Environment.

In addition to this, provide sufficient clearance to allow connection and removal of the PROFIBUS Connector. No unnecessary strain should be placed on the PROFIBUS cable or connector that could be transferred to the Option Board.

2-3-4 PROFIBUS network connector

The PROFIBUS connector on the bottom of the Unit is a 9-pin female sub-D connector, as recommended by IEC 61158. Fixtures have #4/40 UNC thread for compatibility with PROFIBUS-DP connectors. No termination is provided inside the Option Board.

Table 4 PROFIBUS connector pinout

Pin No.	Signal	Description
1	Shield	Functional ground (do not connect)
2	NC	-
3	B-line	Data signal
4	RTS	Control signal for repeaters (direction control)
5	DGND	Signal ground
6	VP	Termination power
7	NC	-
8	A-line	Data signal
9	NC	-

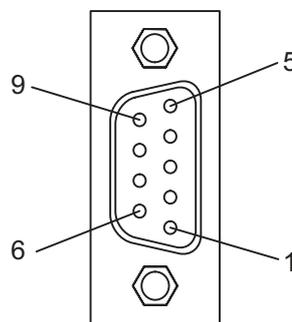

The signals DGND and VP are used to power the bus terminator located in the cable connector.

Note 1 The Option Board allows the use of PROFIBUS connectors with a straight cable outlet.

Note 2 The 9-pin sub-D connector uses #4/40 UNC thread for mechanical fixation of the cable connector. Always use PROFIBUS connectors.

Caution Do not use PROFIBUS connectors with a 90° cable outlet (Such connectors place unnecessary strain on the Option Board connector).

2-3-5 Option Board Dimensions

MX2

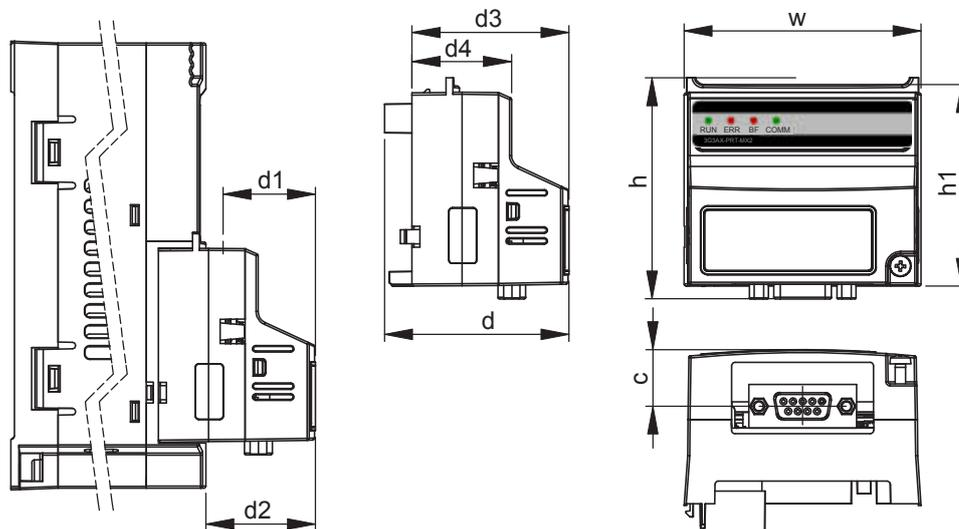

Table 5 Option Board Dimensions

Item	Dimension
h	63.6 mm
h1	57.9 mm
w	67.6 mm

Item	Dimension
c	16.3 mm
d	52.6 mm
d1 ¹	26.4 mm

Item	Dimension
d2	31.3 mm
d3	44.8 mm
d4	28.4 mm

1. Dimension d1 gives the increase in MX2□ Inverter dimension D when the Option Board is fitted (Refer to section 2-3 of the Inverter user's manual).

RX



Table 6 Option Board Dimensions on the RX Inverter

Item	Dimension
p	35.1 mm
q	79.8 mm

Item	Dimension
r	43.9 mm
s	66.5 mm
t	66.1 mm

Item	Dimension
u	31.7 mm
v	32.7 mm
w	48.1 mm

SECTION 3

Configuring Drive Parameters and Option Board

3-1 Configuring the Option Board

All Option Board parameters are stored in the Inverter. This allows for easy replacement of the Option Board without the need to re-configure. After connecting the Option Board to an Inverter for the first time however, proceed with the following steps:

Step 1

The Option Board supports 3 device profiles. Each device profile supports a subset of the modules listed in the GSD file. The device profile is selected using Inverter parameter P182. Use the Inverter keypad to adjust P182 to select the device profile and supported modules.

Table 7 Configuration of device profile

P182	Device Profile	Supported Modules
0 (default)	PROFIdrive [Appendix B]	PPO Type 1 (4 words PKW + 2 words PZD)
		PPO Type 2 (4 words PKW + 6 words PZD)
		PPO Type 3 (2 words PZD)
		PPO Type 4 (6 words PZD)
		PPO Type 5 (4 words PKW + 10 words PZD)
1	Conventional [Appendix C]	Basic Data
		Extended Data 1
		Extended Data 2
2	Flexible [Appendix D]	Flexible (10 words output and input)

Step 2

It is recommended to set C102 = 3 to prevent the Inverter reset input and Stop/reset button from interfering with Option Board during operation (Setting C102 to another value causes the Option Board to reset when a trip condition is cleared). Use the Inverter keypad to set C102 to 3.

Table 8 Configuration of Inverter Reset Mode Selection

Param	Description	Setting
C102	Reset mode selection	Recommended to set to 3 (Reset mode selection resets trip only, not Option Board)

Step 3

Inverter registers P180, P044, P045 and P181 configure the PROFIBUS network-related parameters. Adjust these to configure the node address, CLEAR mode behavior and required action when a Fieldbus failure occurs.

Table 9 Configuration of PROFIBUS parameters

Param	Description	Setting
P180	PROFIBUS Node Address	0 to 125, 0 (default) means node address 126
P044	Network Error Timer	Time to wait after a network error occurs before executing action in P045: 0 to 9999 in 0.1 s units

Table 9 Configuration of PROFIBUS parameters (continued)

Param	Description	Setting
P045	Action on Network Error	Set to 0 for inverter trip Set to 1 for deceleration and trip Set to 2 for no action Set to 3 for stop due to free-run Set to 4 for deceleration and stop
P181	Output Data Keep Mode	Define behavior if PROFIBUS master indicates CLEAR mode or if a network error occurs: Set to 0 for clearing all output data (stop inverter) Set to 1 for keeping output data (inverter continues operating)

Step 4

Registers A001 and A002 are used by the Inverter to adjust the frequency source and control source. If the second motor parameter set is used, registers A201 and A202 also have to be set. Adjust these in accordance with the following table:

Table 10 Configuration of Inverter source selection parameters

Param	Description	Setting
A001	Motor 1 Frequency Source	For option board as source: Set to 3 if P182 equals 2
A201	Motor 2 Frequency Source	MX2 Set to 4 if P182 equals 0 or 1 RX Set to 5 if P182 equals 0 or 1
A002	Motor 1 Run Command Source	
A202	Motor 2 Run Command Source	

Step 5

Registers P033, P036, C021, C022 and C028 are used by the Inverter to adjust some Inverter function sources. If required (refer to usage examples), adjust these in accordance with the following table:



Apply the source selection parameters according the following table for the MX2 Option Board.

Table 11 Configuration of Source selection MX2 parameters

Param	Description	Setting
P033	Torque Command Source	For Option Board as source: Set to 6 (Use Option Board register) if P182 equals 1 Set to 3 (Use P034) if P182 equals 0 or 2
P036	Torque Bias Mode	For Option Board as source: Set to 5 (Bias set by Option Board) if P182 equals 1 Set to 0 (Bias according to sign) or 1 (Bias according to rotation direction) if P182 equals 0 or 2
C021	Output Terminal 11 Source	Set to 63 for Option Board as source
C022	Output Terminal 12 Source	Set to 63 for Option Board as source
C026	Alarm Relay Output Terminal Source	Set to 63 for Option Board as source (Optional)
C028	Analog Output AM Source	Set to 16 for Option Board as source

RX Apply the source selection parameters according the following table for the RX Option Board.

Param	Description	Setting
P033	Torque Command Source	For Option Board as source: Set to 7 (Use Option Board register) if P182 equals 1 Set to 3 (Use P034) if P182 equals 0 or 2
P036	Torque Bias Mode	For Option Board as source: Set to 6 (Bias set by Option Board) if P182 equals 1 Set to 0 (Bias according to sign) or 1 (Bias according to rotation direction) if P182 equals 0 or 2
C021	Output Terminal 11 Source	Set to 63 for Option Board as source
C022	Output Terminal 12 Source	Set to 63 for Option Board as source
C026	Alarm Relay Output Terminal Source	Set to 63 for Option Board as source (Optional)
C028	Analog Output AM Source	Set to 20 for Option Board as source

Step 6

The PPO modules and Flexible module give you the freedom to select/customise the Inverter Modbus registers for Cyclic Data Exchange. Inverter registers P160 - P179 are used to configure and map the exchanged Modbus registers. If required, adjust these registers to change the default content of the exchanged data. Please refer to Appendices *B-1 I/O Mapping* on page 76 and *Flexible I/O Mapping* on page 83 for more details.

Table 12 Configuration of input and output content

Param	Description	Setting
P160	Output Register 1 contents	Modbus register mapped into PZD1 or flexible output word 1
P161	Output Register 2 contents	Modbus register mapped into PZD2 or flexible output word 2
P162	Output Register 3 contents	Modbus register mapped into PZD3 or flexible output word 3
P163	Output Register 4 contents	Modbus register mapped into PZD4 or flexible output word 4
P164	Output Register 5 contents	Modbus register mapped into PZD5 or flexible output word 5
P165	Output Register 6 contents	Modbus register mapped into PZD6 or flexible output word 6
P166	Output Register 7 contents	Modbus register mapped into PZD7 or flexible output word 7
P167	Output Register 8 contents	Modbus register mapped into PZD8 or flexible output word 8
P168	Output Register 9 contents	Modbus register mapped into PZD9 or flexible output word 9
P169	Output Register 10 contents	Modbus register mapped into PZD10 or flexible output word 10
P170	Input Register 1 contents	Modbus register mapped into PZD1 or flexible input word 1
P171	Input Register 2 contents	Modbus register mapped into PZD2 or flexible input word 2
P172	Input Register 3 contents	Modbus register mapped into PZD3 or flexible input word 3
P173	Input Register 4 contents	Modbus register mapped into PZD4 or flexible input word 4

Table 12 Configuration of input and output content (continued)

Param	Description	Setting
P174	Input Register 5 contents	Modbus register mapped into PZD5 or flexible input word 5
P175	Input Register 6 contents	Modbus register mapped into PZD6 or flexible input word 6
P176	Input Register 7 contents	Modbus register mapped into PZD7 or flexible input word 7
P177	Input Register 8 contents	Modbus register mapped into PZD8 or flexible input word 8
P178	Input Register 9 contents	Modbus register mapped into PZD9 or flexible input word 9
P179	Input Register 10 contents	Modbus register mapped into PZD10 or flexible input word 10

Step 7

Restart the Inverter for the changes to take effect.

Note When restarting the Inverter, wait for the Inverter power indicator to go out before switching on again.

 **Caution** Action on Network Error (P045) is disabled when P181 is set to 1 (Keep the output data upon a network failure) I.e. when a network error occurs, the Inverter will continue normal operation with the last received output data.

 **Caution** Check the network related Inverter settings regarding PROFIBUS node address and PROFIBUS map selection. Not doing so may result in unexpected operation.

Tip Alternatively, P180 in Step 3 may be performed using the set-slave address functionality of your PROFIBUS master or diagnostic tool.

Tip Alternatively, Step 2 up to Step 6 may be performed using OMRON CX-Drive.

Tip Alternatively, Step 7 may be performed by resetting the Option Board using PNU972 (Refer to APPENDIX F Option Board Parameters).

3-2 Configuring the Network

Step 1  Download the GSD file named OC_0C6A for the Option Board via the Omron website <http://industrial.omron.eu>.

 Download the GSD file named OC_0D2B for the Option Board via the Omron website <http://industrial.omron.eu>.

Step 2 Install / add this GSD file to the PROFIBUS master configuration program used to configure your PROFIBUS master.
(It may be necessary to update the device catalogue before proceeding)

Step 3 Add your PROFIBUS master to the network in the configuration program.

Step 4 Add an Option Board to the network in the configuration program and open the Option Board's settings.

Step 5 Set the Option Board's node address (also referred to as station address) to match P180 in the Inverter.

Step 6 Choose a module that is supported by the selected device profile (Inverter parameter P182).

Table 13 Configuration of module support

P182	Device Profile	Supported Modules
0 (default)	PROFIdrive [Appendix B]	PPO Type 1 (4 words PKW + 2 words PZD)
		PPO Type 2 (4 words PKW + 6 words PZD)
		PPO Type 3 (2 words PZD)
		PPO Type 4 (6 words PZD)
		PPO Type 5 (4 words PKW + 10 words PZD)
1	Conventional [Appendix C]	Basic Data
		Extended Data 1
		Extended Data 2
2	Flexible [Appendix D]	Flexible (10 words output and input)

Step 7 Uncheck the Enable DPV1 option on the DPV1 tab before proceeding to Step 7 if you are using OMRON CX-Configurator.

Step 8 Save and download the configuration to your PROFIBUS master.

Step 9 Once the network is re-started with the new settings, check that the Option Board LED indicators indicate proper operation: If everything is correctly configured, only the RUN and COMM indicators will be ON (green). Please refer to section 5-1 *Troubleshooting using the LED indicators* on page 57 to troubleshooting any configuration errors if the LED indicators are displaying a different pattern.

Note Nothing prevents you from selecting an unsupported module in Step 6. If you are uncertain, check the value of P182 before selecting the module.

Tip Refer to *SECTION 5 Troubleshooting and Maintenance* on page 57 in case of errors.

SECTION 4

Operations and Monitoring

This section provides some common usage examples to help you get started. Unless otherwise specified, all usage examples make use of the PROFIdrive device profile and associated modules (Refer to section 3-1 *Configuring the Option Board, Step 1*). Prepare the Inverter and Option Board before starting with the usage examples:

Step 1

Initialize the Inverter mode to Induction Motor, Constant Torque:

MX2 Set b171 = 1 and then b180 = 1, set b049 = 0.

Refer to MX2 User's manual (Cat. No. I570) section 3-6-24.

RX Set b084 = 2 and then b180 = 1, set b049 = 0.

Refer to RX User's manual (Cat. No. I560) section 4-2 Parameter Initialization).

Step 2

Configure the Option Board and Network as explained in sections 3-1 *Configuring the Option Board* and 3-2 *Configuring the Network*, but limit the following choices:

- When selecting the device profile when configuring the Option Board (*Step 1* of section 3-1 *Configuring the Option Board*), select the PROFIdrive device profile by setting P182 to 0.
- When configuring the process area content (of section 3-1 *Configuring the Option Board*), set all parameters (P160 - P179 to 0).
- When choosing the module while configuring the network (*Step 6* of section 3-2 *Configuring the Network*), select either the PPO Type 2 or PPO Type 5 module.

If you configured everything correctly, your output and input process areas should contain the following data:

Table 14 Output Process Area

Word offset	+0	+1	+2	+3	+4	+5	+6	+7	+8	+9
Register	PKE	IND	PWE		STW	HSW	-	-	-	-
Value	dec	0	0	0	0	0	0	0	0	0
	hex	0000	0000	00000000	0000	0000	0000	0000	0000	0000

Bit	15	14	13	12	11	10	9	8	7	6	5	4	3	2	1	0
Name	-	-	-	-	-	Ovr	JR	JF	Rst	-	-	Run	En	-	-	-
Value	0	0	0	0	0	0	0	0	0	0	0	0	0	0	0	0

PKE	Task ID and parameter number	Ovr	Control override
IND	Parameter index	JR	Jog run reverse
PWE	Parameter value	JF	Jog run forward
STW	Control word	Rst	Fault reset
HSW	Frequency reference	Run	Run operation
		En	Run enable

WARNING

MX2 A revision AAAA Inverter allows the motor to run immediately if a trip condition is reset, and at the same time, Run (STW) is set. For safe operation clear Run (STW) when you detect a rising-edge on Flt (ZSW). Refer to section 1-1-2 Inverter Support to determine the Inverter revision.

Table 15 Input Process Area

Word offset	+0	+1	+2	+3	+4	+5	+6	+7	+8	+9
Register	PKE	IND	PWE		ZSW	HW	-	-	-	-
Value	dec	0	0	0	55	0	0	0	0	0
	hex	0000	0000	00000000	0037	0000	0000	0000	0000	0000

Bit	15	14	13	12	11	10	9	8	7	6	5	4	3	2	1	0
Name	-	-	-	-	-	-	CS	FA	Alm	-	-	-	Flt	Rdy	AC	-
Value	0	0	0	0	0	0	0	0	0	0	1	1	0	1	1	1

PKE Task response and parameter number CS Control status
 IND Parameter index FA Frequency arrival
 PWE Parameter value or error code Alm Alarm
 ZSW Status word Flt Fault
 HW Output frequency Rdy Ready for operation
 AC AC mains detected

Note 1 Depending on your source selection, CS may already be 1 on your setup.

Note 2 For compatibility, some unsupported bits in ZSW are always 1.

Caution Check the Inverter settings for proper Inverter behavior before actually operating the Inverter remotely via the PROFIBUS network.

Caution The product will be used to control an adjustable speed drive connected to high voltage sources and rotating machinery that is inherently dangerous if not operated safely. Interlock all energy sources, hazardous locations, and guards in order to restrict the exposure of personnel to hazards. The adjustable speed drive may start the motor without warning. Signs on the equipment installation must be posted to this effect. A familiarity with auto-restart settings is a requirement when controlling adjustable speed drives. Failure of external or ancillary components may cause intermittent system operation, i.e., the system may start the motor without warning or may not stop on command. Improperly designed or improperly installed system interlocks and permissives may render a motor unable to start or stop on command.

4-1 Source Selection

First select the appropriate control and frequency sources, before operating the Inverter. We will be using the 1st motor:

Step 1 **MX2** Set A001=4 and A002=4 so that the Inverter is controlled by the default PRO-Fldrive control and frequency references registers.

RX Set A001=5 and A002=5 so that the Inverter is controlled by the default PRO-Fldrive control and frequency references registers.

Note The control override bit in the PROFIdrive control word (Section B-2 Control and Status Words - STW/ZSW) can be used to override A001, A201, A002 and A202. When this bit is set, it has the same effect as temporarily setting A001, A201, A002 and A202=4. Clearing this bit removes the override, and the Inverter sources are once again determined by these registers.

MX2 If you are using a version AAAA Inverter, the control override bit is always disabled if A002 = 2.

4-2 Operating the Motor

4-2-1 Starting the Motor

- Step 1 Set the En bit to enable controlled acceleration and deceleration of the motor.
- Step 2 Set the Run bit to put the Inverter in run mode. The RUN indicator on the Inverter should light up at this point. If this is not the case, check your source selection (Section 4-1 Source Selection).
- Step 3 Set HIW=1000 (10.00 Hz forward).

Table 16 Output Process Area with Motor Started

Word offset	+0	+1	+2	+3	+4	+5	+6	+7	+8	+9
Register	PKE	IND	PWE		STW	HSW	-	-	-	-
Value	dec	0	0	0	24	+1000	0	0	0	0
	hex	0000	0000	00000000	0018	03E8	0000	0000	0000	0000

Bit	15	14	13	12	11	10	9	8	7	6	5	4	3	2	1	0
Name	-	-	-	-	-	Ovr	JR	JF	Rst	-	-	Run	En	-	-	-
Value	0	0	0	0	0	0	0	0	0	0	0	1	1	0	0	0

The motor accelerates until it reaches the desired frequency. Notice that the FA bit is set once the inverter has reached the desired reference frequency.

Table 17 Input Process Area with Reference Frequency Reached

Word offset	+0	+1	+2	+3	+4	+5	+6	+7	+8	+9
Register	PKE	IND	PWE		ZSW	HIW	-	-	-	-
Value	dec	0	0	0	823	+1000	0	0	0	0
	hex	0000	0000	00000000	0337	03E8	0000	0000	0000	0000

Bit	15	14	13	12	11	10	9	8	7	6	5	4	3	2	1	0
Name	-	-	-	-	-	-	CS	FA	Alm	-	-	-	Flt	Rdy	AC	-
Value	0	0	0	0	0	0	1	1	0	0	1	1	0	1	1	1

4-2-2 Changing Direction

- Step 4 Set HIW=-1000 (10.00 Hz reverse).

Table 18 Output Process Area with Motor Set to Run Reverse

Word offset	+0	+1	+2	+3	+4	+5	+6	+7	+8	+9
Register	PKE	IND	PWE		STW	HSW	-	-	-	-
Value	dec	0	0	0	24	-1000	0	0	0	0
	hex	0000	0000	00000000	0018	FC18	0000	0000	0000	0000

The motor decelerates, stops and then accelerates in the opposite direction. The FA bit clears as soon as the reference frequency is changed. Once the new reference frequency is reached, the FA bit is once again set.

Table 19 Input Process Area with Reverse Frequency Reached

Word offset	+0	+1	+2	+3	+4	+5	+6	+7	+8	+9
Register	PKE	IND	PWE		ZSW	HIW	-	-	-	-
Value	dec	0	0	0	823	-1000	0	0	0	0
	hex	0000	0000	00000000	0337	FC18	0000	0000	0000	0000

Bit	15	14	13	12	11	10	9	8	7	6	5	4	3	2	1	0
Name	-	-	-	-	-	-	CS	FA	Alm	-	-	-	Flt	Rdy	AC	-
Value	0	0	0	0	0	0	1	1	0	0	1	1	0	1	1	1

4-2-3 Stopping the Motor - Controlled

Step 5

Clear the Run bit to bring the motor to a controlled stop.

Table 20 Output Process Area for Controlled Stop

Word offset	+0	+1	+2	+3	+4	+5	+6	+7	+8	+9
Register	PKE	IND	PWE		STW	HSW	-	-	-	-
Value	dec	0	0	0	8	-1000	0	0	0	0
	hex	0000	0000	00000000	0008	FC18	0000	0000	0000	0000

Bit	15	14	13	12	11	10	9	8	7	6	5	4	3	2	1	0
Name	-	-	-	-	-	Ovr	JR	JF	Rst	-	-	Run	En	-	-	-
Value	0	0	0	0	0	0	0	0	0	0	0	0	1	0	0	0

The motor decelerates, and comes to a stop. The FA bit clears as soon as the Run bit is cleared.

Table 21 Input Process Area after Controlled Stop

Word offset	+0	+1	+2	+3	+4	+5	+6	+7	+8	+9
Register	PKE	IND	PWE		ZSW	HIW	-	-	-	-
Value	dec	0	0	0	567	0	0	0	0	0
	hex	0000	0000	00000000	0237	0000	0000	0000	0000	0000

Bit	15	14	13	12	11	10	9	8	7	6	5	4	3	2	1	0
Name	-	-	-	-	-	-	CS	FA	Alm	-	-	-	Fit	Rdy	AC	-
Value	0	0	0	0	0	0	1	0	0	0	1	1	0	1	1	1

Before continuing set HSW to 0.

Note The motor can also be brought to a stop by setting HSW to 0 and leaving the Run bit set. The Inverter will however stay in run mode once the motor has stopped.

4-2-4 Stopping the Motor - Free-running

An alternative to Step 5 is to clear the En bit to request a free-run stop: The Inverter stops controlling the motor, and the motor coasts to a stop. During a free-run stop, you will notice that HIW immediately drops to 0 and the FA bit is cleared.

4-2-5 Jog Operation

Step 6

Set the JF bit to start the jog operation.

Table 22 Output Process Area with Motor Jogging Forward

Word offset	+0	+1	+2	+3	+4	+5	+6	+7	+8	+9
Register	PKE	IND	PWE		STW	HSW	-	-	-	-
Value	dec	0	0	0	264	0	0	0	0	0
	hex	0000	0000	00000000	0108	0000	0000	0000	0000	0000

Bit	15	14	13	12	11	10	9	8	7	6	5	4	3	2	1	0
Name	-	-	-	-	-	Ovr	JR	JF	Rst	-	-	Run	En	-	-	-
Value	0	0	0	0	0	0	0	1	0	0	0	0	1	0	0	0

The motor immediately starts rotating forward at the pre-set jog frequency. The Inverter jog frequency can be set by adjusting Inverter parameter A038. When jogging, the Inverter immediately jumps to the jog frequency. No controlled acceleration is performed and the FA bit is immediately set.

Table 23 Input Process Area with Motor Jogging Forward

Word offset	+0	+1	+2	+3	+4	+5	+6	+7	+8	+9
Register	PKE	IND	PWE		ZSW	HIW	-	-	-	-
Value	dec	0	0	0	823	+600	0	0	0	0
	hex	0000	0000	00000000	0337	0258	0000	0000	0000	0000

Bit	15	14	13	12	11	10	9	8	7	6	5	4	3	2	1	0
Name	-	-	-	-	-	-	CS	FA	Alm	-	-	-	Flt	Rdy	AC	-
Value	0	0	0	0	0	0	1	1	0	0	1	1	0	1	1	1

Note 1 To jog the motor in reverse, set the JR bit.

4-2-6 Frequency Reference and Output Frequency Scaling

HSW and HIW are signed word registers. Using normal scaling, you will therefore not be able to set HSW higher than 327.67 Hz (327.68 Hz in reverse).

MX2 The MX2 Inverter can however be set to operate in HF mode. Refer to the MX2 User Manual section 3-6-24 for instructions on how to achieve this.

Doing this changes the scaling of HSW and HIW to 0.1 Hz. At 0.1 Hz scaling you will be able to reach the full frequency range of the inverter by adjusting HSW.

4-3 Customising the Process Area

The PROFIdrive device profile also gives you the capability to customise the process area by mapping your choice of Modbus registers. Normally, P160, P161, P170 and P171 are set to 0 so that STW, HSW, ZSW and HIW are exchanged. The remaining parameters (P162 - P169 and P172 - P179) are normally used to map additional Modbus registers into the cyclically exchanged process areas. User parameters P160 - P169 configure the output process area mappings where parameters P170 - P179 configure the input process area mappings.

4-3-1 Double-word Frequency Reference and Output Frequency

HSW and HIW are signed word registers. Using normal scaling, you will therefore not be able to set HSW higher than 327.67 Hz (327.68 Hz in reverse) unless you are using the Inverter HF mode. You can however directly use the Inverter DWORD registers F001 and d001 to increase the usable range:

These two registers offer fixed 0.01 Hz scaling while still allowing you to control the Inverter through its full frequency range. When using the PROFIdrive device profile, the F001 and d001 registers are also sign converted by the Option Board. You can therefore use F001 and d001 as functional substitutes for HSW and HIW.

- Step 1** Set parameters P161 and P162 to 0001h and 0002h to map Modbus registers 0001h and 0002h (Function code F001) into output PZD2 and PZD3.
- Step 2** Set parameters P171 and P172 to 1001h and 1002h to map Modbus registers 1001h and 1002h (Function code d001) into input PZD2 and PZD3.
- Step 3** Set A001=3 to use F001 as the Inverter frequency source (Note that you cannot make use of the Ovr bit in STW to take control of the Inverter when using F001 to control the reference frequency).
- Step 4** Restart the Inverter or reset the Option Board for the changes to take effect.

Tip If the Inverter trips after restarting, check that you correctly set P161, P162, P171 and P172, and that all other registers in the P160 - P179 range are set to 0.

Your input and output process areas should now have the following layout:

Table 24 Output Process Area with Double Word Frequency Reference

Word offset	+0	+1	+2	+3	+4	+5	+6	+7	+8	+9
Register	PKE	IND	PWE		STW	F001 (0001h/0002h)		-	-	-
Value	dec	0	0	0	0	0	0	0	0	0
	hex	0000	0000	00000000	0000	0000	0000	0000	0000	0000

Table 25 Input Process Area with Double Word Output Frequency

Word offset	+0	+1	+2	+3	+4	+5	+6	+7	+8	+9
Register	PKE	IND	PWE		ZSW	d001 (1001h/1002h)		-	-	-
Value	dec	0	0	0	567	0	0	0	0	0
	hex	0000	0000	00000000	0237	0000	0000	0000	0000	0000

Step 5

To turn the motor forward, set the Run and En bits in STW and change F001 (output PZD2 and PZD3) to the desired frequency. (Input PZD2 represents the most-significant word and input PZD3 the least-significant word)

Table 26 Output Process Area with Forward Rotation Dword Frequency Reference

Word offset	+0	+1	+2	+3	+4	+5	+6	+7	+8	+9
Register	PKE	IND	PWE		STW	F001 (0001h/0002h)		-	-	-
Value	dec	0	0	0	24	+1000		0	0	0
	hex	0000	0000	00000000	0018	0000	03E8	0000	0000	0000

The output frequency is given by d001 (input PZD2 contains the most-significant and input PZD3 the least-significant word).

Table 27 Input Process Area with Forward Rotation Dword Output Frequency

Word offset	+0	+1	+2	+3	+4	+5	+6	+7	+8	+9
Register	PKE	IND	PWE		ZSW	d001 (1001h/1002h)		-	-	-
Value	dec	0	0	0	823	+1000		0	0	0
	hex	0000	0000	00000000	0337	0000	03E8	0000	0000	0000

Step 6

To reverse the motor, change F001 (output PZD2 and PZD3) to a negative signed double-word frequency.

Table 28 Output Process Area with Reverse Rotation Dword Frequency Reference

Word offset	+0	+1	+2	+3	+4	+5	+6	+7	+8	+9
Register	PKE	IND	PWE		STW	F001 (0001h/0002h)		-	-	-
Value	dec	0	0	0	24	-1000		0	0	0
	hex	0000	0000	00000000	0018	FFFF	FC18	0000	0000	0000

The motor decelerates, stops and then accelerates in the opposite direction.

Table 29 Input Process Area with Reverse Rotation Dword Output Frequency

Word offset	+0	+1	+2	+3	+4	+5	+6	+7	+8	+9
Register	PKE	IND	PWE		ZSW	d001 (1001h/1002h)		-	-	-
Value	dec	0	0	0	823	-1000		0	0	0
	hex	0000	0000	00000000	0337	FFFF	FC18	0000	0000	0000

The remainder of the examples do not make use of double-word frequency registers. Set P160, P161, P170 and P171 back to 0, A001 back to 4 and restart the Inverter or reset the Option Board before following further examples.

Note If you want to use a DINT to write or read an Inverter double-word register, you will have to swap the high- and low-word in your PLC program (For double-words, an OMRON PLCs does not use the same word-order convention than the Inverter).

4-3-2 Mapping Coil Data 0

Modbus coils 0000h though 000Fh offer a large amount of functionality. The intelligent input terminal overrides (Coils 0007h though 000Dh) for example can be used to control any of the Inverter's assignable input terminal functions.

MX2 Refer to section 3-7-2 of the MX2 Inverter User's manual.

RX Refer to section 4-2 "Multi-function input selection" of the RX Inverter User's manual.

The following example illustrates how to map Modbus coils 0000h though 000Fh into PZD3:

Step 1 Set parameters P162 to 1F01h to map coil data 0 into output PZD3.

Step 2 Restart the Inverter or reset the Option Board for the changes to take effect.

Table 30 Output Process Area with Modbus Coil Data 0

Register	PKE	IND	PWE	STW	HSW	Coil data 0	-	-	-
Value	dec	0	0	0	0	0	0	0	0
	hex	0000	0000	00000000	0000	0000	0000	0000	0000

Bit	15	14	13	12	11	10	9	8	7	6	5	4	3	2	1	0
Name	-	In8 ^{RX}	In7	In6	In5	In4	In3	In2	In1	-	-	- ¹	EXT	- ¹	- ¹	-
Value	0	0	0	0	0	0	0	0	0	0	0	0	0	0	0	0

EXT External Trip
 In1 Intelligent input terminal [1] override
 In2 Intelligent input terminal [2] override
 In3 Intelligent input terminal [3] override
 In4 Intelligent input terminal [4] override
 In5 Intelligent input terminal [5] override
 In6 Intelligent input terminal [6] override
 In7 Intelligent input terminal [7] override
 In8^{RX} Intelligent input terminal [8] override

RX ^{RX} : Is only applicable for the RX Inverter

Note 1 It is not possible or practical to use all the coils contained in Coil data 0 when the Option Board is using the PROFIdrive device profile:

- The operation (0001h) and rotation direction (0002h) coils are not used by the Inverter when the run command source (A002) is set to 4 or 5 (Option Board).
- The trip reset coil (0004h) duplicates the functionality of Rst in STW.
- The operation status coil (000Fh) is not writeable.

Step 3 The Modbus coils 0000h though 000Fh are now available for use via PZD3. Use parameters C001 to C007 to assign Inverter functions to any of the intelligent input terminals. To activate an assigned function, set the corresponding input terminal override (bits 7 to 13 in coil data 0).

4-3-3 Controlling Inverter Torque

In addition to frequency control, the Inverter allows direct control of the motor torque.

Caution Before following this example, disconnect your motor from any load to prevent injury or damage to property.

The following example explains how to make use of the Option Board to control the motor torque:

Step 1 Set parameter P162 to 1F01h to map coil data 0 into output PZD3.

Step 2 Set parameter P163 to 1622h to map the torque command level input (P034) into output PZD4.

Step 3 Set parameter P173 to 1010h to map the torque monitor (d012) into input PZD4.

Step 4 Set parameter C001=52 (ATR: permission of torque command input) to use intelligent input terminal 1 as torque enable.

Prepare the Inverter for torque mode:

- MX2** • Set parameter A044=3 to enable Sensorless Vector Control (SLV).
- RX** • Refer to section 4-3 of the RX User manual (I560) to set the torque mode.

Step 5 **MX2** Set parameter P033=6 to assign Torque command input selection to the Option Board Interface.

RX Set parameter P033=7 to assign Torque command input selection to the Option Board Interface 2.

Step 6 Restart the Inverter or reset the Option Board for the new settings to take effect.

Restart the Inverter or reset the Option Board for the new settings to take effect. If the Inverter trips after restarting with an E64 / E74 and parameters P162, P163 and P172 appear to be configured correctly, it is likely that you made a mistake in Step 1 or Step 2 (The Inverter will only allow mapping of torque registers in the process area if it is configured to operate with CT rating in Std. IM mode).

Note The Inverter will only allow setting of torque related registers if it is configured to operate with CT rating in Std. IM mode.

Your input and output process areas should now have the following layout:

Table 31 Output Process Area Configured for Torque Control

Word offset	+0	+1	+2	+3	+4	+5	+6	+7	+8	+9
Register	PKE	IND	PWE		STW	HSW	Coil data 0	P034	-	-
Value	dec	0	0	0	0	0	0	0	0	0
	hex	0000	0000	00000000	0000	0000	0000	0000	0000	0000

Bit	15	14	13	12	11	10	9	8	7	6	5	4	3	2	1	0
Name	-	In8 ^{RX}	In7	In6	In5	In4	In3	In2	ATR	-	-	-	EXT	-	-	-
Value	0	0	0	0	0	0	0	0	0	0	0	0	0	0	0	0

- EXT External Trip
- ATR Torque command input enable
- In2 Intelligent input terminal [2] override
- In3 Intelligent input terminal [3] override
- In4 Intelligent input terminal [4] override
- In5 Intelligent input terminal [5] override
- In6 Intelligent input terminal [6] override
- In7 Intelligent input terminal [7] override
- In8^{RX} Intelligent input terminal [8] override

RX ^{RX} : Is only applicable for the RX Inverter

Table 32 Input Process Area Configured for Torque Control

Word offset	+0	+1	+2	+3	+4	+5	+6	+7	+8	+9
Register	PKE	IND	PWE		ZSW	HIW	-	D012	-	-
Value	dec	0	0	0	667	0	0	0	0	0
	hex	0000	0000	00000000	0297	0000	0000	0000	0000	0000

Step 7 Set the maximum allowable output frequency in torque mode by configuring P039 and P040 for the forward and reverse run directions. Be careful to select safe limits for your test setup.

Step 8 Set the En and Run bits in STW to enable controlled acceleration and deceleration and put the Inverter in run mode.

Step 9 Set HIW=+1000 (10.00 Hz forward) to accelerate the motor to a constant forward output frequency.

Step 10 Select the desired output torque by setting P034 (output PZD4)=+20 (20% forward torque).

Step 11 Set the ATR bit in coil data 0 (output PZD3) to enable torque command input.

Table 33 Output Process Area Configured with Forward Torque Command

Word offset	+0	+1	+2	+3	+4	+5	+6	+7	+8	+9
Register	PKE	IND	PWE		STW	HSW	Coil data 0	P034	-	-
Value	dec	0	0	0	24	+1000	128	+20	0	0
	hex	0000	0000	00000000	0018	03E8	0080	0014	0000	0000

Bit	15	14	13	12	11	10	9	8	7	6	5	4	3	2	1	0
Name	-	In8 ^{RX}	In7	In6	In5	In4	In3	In2	ATR	-	-	-	EXT	-	-	-
Value	0	0	0	0	0	0	0	0	1	0	0	0	0	0	0	0

RX

In8^{RX}: Is only applicable for the RX Inverter, Intelligent input terminal [8] override

The motor either accelerates or decelerates depending on the load. The output frequency is limited by the P039 setting. The output torque is given by d012 (input PZD4).

Step 12

To change the torque command direction, set both HSW=-1000 (10.00 Hz reverse) and P034 (output PZD4)=-20 (20% reverse torque).

Table 34 Output Process Area Configured with Reverse Torque Command

Word offset	+0	+1	+2	+3	+4	+5	+6	+7	+8	+9
Register	PKE	IND	PWE		STW	HSW	Coil data 0	P034	-	-
Value	dec	0	0	0	24	-1000	128	-20	0	0
	hex	0000	0000	00000000	0018	FC18	0080	FFEC	0000	0000

Bit	15	14	13	12	11	10	9	8	7	6	5	4	3	2	1	0
Name	-	In8 ^{RX}	In7	In6	In5	In4	In3	In2	ATR	-	-	-	EXT	-	-	-
Value	0	0	0	0	0	0	0	0	1	0	0	0	0	0	0	0

RX

In8^{RX}: Is only applicable for the RX Inverter, Intelligent input terminal [8] override

The motor decelerates and accelerates in the opposite direction. The output frequency is limited by the P040 setting. Note that the output torque given by d012 (input PZD4) now has a negative sign to indicate that the torque direction is reversed.

Tip

To keep your application compatible with all revisions of the Inverter, keep the sign of HIW and P034 the same.

MX2

The torque direction is controlled by the sign of HIW when using the Inverter revision AAAA. On later releases, the sign of P034 controls the torque direction.

4-3-4 Mapping Restrictions

Before you start customizing the process area, it is necessary to note the Inverter places some restrictions on the customizing.

If your configuration is rejected by the Inverter, you got assist in sections 5-1-3 Configuration Errors and 5-2-2 Extended Diagnostic Information of this manual.

MX2

If you want to avoid configuration rejection, observe the following rules for the MX2:

- Set all unused PZDs to default by setting the associated configuration register to 0.
- Only map Modbus registers listed in appendix B of the MX2 Inverter user's manual.
- Do not map a Modbus register more than once in the output process area.
- Always map both high- and low-words of a double-word Modbus register next to each other in the process area. Also make sure that they are in the correct sequence (high-word followed by low-word).

- Only map a Modbus registers in the output process area if it is writeable. A register is writeable if it has an 'R/W' or a 'W' in the 'R/W' column in section B-4-2 of the MX2 Inverter user's manual.
- Only map a Modbus register in the output process area if it is run-mode editable. Refer to section 3-2-3 of the MX2 Inverter user's manual for an explanation of run-mode editable registers. Also note that the run-mode edit requirement can be disabled with b031.



If you want to avoid configuration rejection, observe the following rules for the RX:

- Set all unused PZDs to default by setting the associated configuration register to 0.
- Only map Modbus registers listed in section 4.4 Register Number List of the RX Inverter user's manual.
- Do not map a Modbus register more than once in the output process area.
- Always map both high- and low-words of a double-word Modbus register next to each other in the process area. Also make sure that they are in the correct sequence (high-word followed by low-word).
- Only map a Modbus registers in the output process area if it is writeable. A register is writeable if it has an 'R/W' or a 'W' in the 'R/W' column in section 4.4 Register Number List of the RX Inverter user's manual.
- Only map a Modbus register in the output process area if it is run-mode editable. Refer to Appendix 1 of the RX Inverter user's manual for an explanation of run-mode editable registers. Also note that the run-mode edit requirement can be disabled with b031.

4-4 Faults and Trips

4-4-1 External Trip

You may want to trip the Inverter from your PLC program. The PROFIdrive device profile does not provide a standard interface to achieve this, but you can use the Modbus coil number 0003h to generate an external trip (EXT):

Step 1

Follow the instructions in section 4-3-2 *Mapping Coil Data 0* to map Coil data 0 into PZD3.

Step 2

Set bit 3 (EXT) of Coil data 0 which has been mapped into PZD3 to trip the Inverter.

Table 35 Output Process Area when Using EXT to Trip Inverter

Word offset	+0	+1	+2	+3	+4	+5	+6	+7	+8	+9
Register	PKE	IND	PWE		STW	HSW	Coil data 0	-	-	-
Value	dec	0	0	0	8	0	0	0	0	0
	hex	0000	0000	00000000	0008	0000	0008	0000	0000	0000

Bit	15	14	13	12	11	10	9	8	7	6	5	4	3	2	1	0
Name	Stat	In8 ^{TR}	In7	In6	In5	In4	In3	In2	In1	-	-	RS	EXT	Dir	Op	-
Value	0	0	0	0	0	0	0	0	0	0	0	0	1	0	0	0

In8^{TR}: Is only applicable for the RX Inverter, Intelligent input terminal [8] override

Table 36 Input Process Area with Inverter Tripped

Word offset	+0	+1	+2	+3	+4	+5	+6	+7	+8	+9
Register	PKE	IND	PWE		ZSW	HIW	-	-	-	-
Value	dec	0	0	0	571	0	0	0	0	0
	hex	0000	0000	00000000		023B	0000	0000	0000	0000

Bit	15	14	13	12	11	10	9	8	7	6	5	4	3	2	1	0
Name	-	-	-	-	-	-	CS	FA	Alm	-	-	-	Flt	Rdy	AC	-
Value	0	0	0	0	0	0	1	0	0	0	1	1	1	0	1	1

Note 1 Notice that the Inverter trips with an E12, the Flt bit is set and the Rdy bit cleared.

4-4-2 Clearing a Trip

! WARNING

In the event that the Inverter trips, be sure to investigate the cause of this trip thoroughly before clearing the trip. Not checking the cause may result in unexpected operation. Refer to section 5-1 *Troubleshooting using the LED indicators* or section 5-2 *Troubleshooting Using PROFIBUS Diagnostics*.

Step 3

You must always immediately clear the Run bit in your PLC program when a rising edge is detected on Flt. If the Run bit is set when the trip condition is cleared, the Inverter will immediately start running!

Step 4

Set the Rst bit in the STW register to clear the trip.

Table 37 Output Process Area when Clearing Trip

Word offset	+0	+1	+2	+3	+4	+5	+6	+7	+8	+9
Register	PKE	IND	PWE		STW	HSW	-	-	-	-
Value	dec	0	0	0	136	0	0	0	0	0
	hex	0000	0000	00000000		0088	0000	0000	0000	0000

Bit	15	14	13	12	11	10	9	8	7	6	5	4	3	2	1	0
Name	-	-	-	-	-	Ovr	JR	JF	Rst	-	-	Run	En	-	-	-
Value	0	0	0	0	0	0	0	0	1	0	0	0	1	0	0	0

! WARNING

Always clear the Run bit (STW) in your PLC program on a rising-edge of Flt (ZSW). Not doing so may result in the motor starting unexpectedly when the trip is cleared via PROFIBUS or the "Stop/reset" button on the Inverter.

4-5 Accessing Parameters

4-5-1 Parameter Processing Message Area - PKW

Table 38 Input and Output Parameter Processing Message Area-PKW

Word offset	+0		+1		+2	+3
Bits	15-12	10-0	15-8	7-0	15-0	15-0
Register	PKE		IND	-	PWE	
	AK	PNU			High word	Low word
Value [hex]	0	000	00	00	0000	0000

AK Task ID / Task response
 PNU Parameter number
 PWE Parameter value / error code
 IND Parameter group of the Inverter parameter, or element index in Option Board parameter array

You can use the parameter processing message area to read or write parameters via the output- and input process areas. You can use any of the following tasks by writing the task number to AK in the output process area.

Table 39 Parameter Processing Tasks

AK	Task description
0	Clear the input message area
1	Read parameter value
2	Change WORD parameter value
3	Change DWORD parameter value
6	Read element value in array
7	Change WORD element value in array
8	Change DWORD element value in array
9	Read array size

Some parameters contain arrays and have to be accessed using array tasks (Tasks 6, 7 and 8). Array tasks use IND to address the element number in an array.

When the Option Board completes the task, a task response is written to AK in the input process area. The size of the parameter is given by the task response number.

Table 40 Parameter Processing Task Responses

AK	Task description
0	No response
1	Task success (WORD parameter)
2	Task success (DWORD parameter)
4	Task success (WORD element)
5	Task success (DWORD element)
6	Task success (Array size)
7	Task failed (Parameter)
8	Task failed (Element)

If you executed an array tasks, you will accordingly receive an array task response ID (Task response 4, 5 or 8).

When a read task succeeds, the Option Board also writes the value to PWE in the input process area.

When you start a write task, you must also write the new parameter value to PWE in the output process area.

When a task fails, the Option Board writes a 7 or 8 (Task failed) to AK and an error number to PWE in the input process area. All error numbers are listed in *APPENDIX G PROFIdrive Error Numbers*.

Note If you want to use a DINT to write or read PWE, you will have to swap the high- and low-word in your PLC program (For double-words, an OMRON PLCs does not use the same word-order convention than PROFIBUS).

Note The parameter processing message area is only available when using the PPO Type 1, PPO Type 2 or PPO Type 5 module. To access parameters when using the PPO Type 3 or PPO Type 4 module, make use of the PROFIdrive DP-V1 parameter channel (Refer to section 4-5-2 *PROFIdrive DP-V1 Parameter Channel*).

Tip Use the following sequence when starting a read or write task:

1. Set AK=0.
2. Set PNU, IND and PWE.

3. Set AK to the desired task.

The parameter processing message mailbox is triggered by a change in the parameter processing output area. By first setting AK=0, you avoid unintentionally starting a write task when you start changing PNU, IND and PWE.

4-5-1-1 Accessing Option Board Parameters

Option Board parameters are addressed by writing the parameter number to PNU (Refer to *APPENDIX F Option Board Parameters* for a list of the available Option Board parameters). If you are addressing an element in an Option Board parameter array, you must also write the element index to IND. When writing an Option Board parameter, the task number specifies the write size.

The following example demonstrates how to use the parameter process message area to access Option Board parameters:

Step 1

Reading an Option Board Parameter: To read Option Board parameter 965 (Unit profile code): First set PNU and then AK as illustrated below. The Option Board will respond with the illustrated values.

Table 41 Parameter Processing Message Area-Reading PNU965

		Read parameter value task				
		Parameter number 965				
Output area [hex]	1	3C5	00	00	0000	0000
Word offset		+0	+1	+2	+3	
Function	AK	PNU	IND	-	PWE	
Input area [hex]	1	3C5	00	00	0000	0302
		Task success (WORD parameter) response				
		Read value (The unit profile code)				

Step 2

Reading an Option Board array element: To read Option Board parameter element 915.3 (Modbus address mapped into PZD3): Set PNU=393h (915 dec), AK=6 and IND=3.

Table 42 Parameter Processing Message Area-Reading PNU915.3

		Read element value in array task				
		Parameter number 915				
		Element at index 3				
Output area [hex]	6	393	03	00	0000	0000
Word offset		+0	+1	+2	+3	
Function	AK	PNU	IND	-	PWE	
Input area [hex]	4	393	03	00	0000	0000
		Task success (WORD element) response				
		Read value (Modbus address mapped into PZD3)				

Step 3

Changing an Option Board array element: To change Option Board parameter element 915.3 (Modbus address mapped into PZD3) to 1F01h (Coil data 0):

Table 43 Parameter Processing Message Area-Changing PNU915.3

		Change WORD element value in array task				
		Parameter number 915				
		Element at index 3				
		Write value				
Output area [hex]	7	393	03	00	0000	1F01
Word offset		+0	+1	+2	+3	
Function	AK	PNU	IND	-	PWE	
Input area [hex]	4	393	03	00	0000	0000
		Task success (WORD element) response				

Step 4

Storing changed parameter(s): To store changed parameter(s) in non-volatile memory, write a 1 to Option Board parameter 971:

Table 44 Parameter Processing Message Area-Initiating NV Store

		Change WORD parameter value task Parameter number 971				Write
Output area [hex]	2	3CB	00	00	0000	0001
Word offset		+0	+1	+2	+3	
Function	AK	PNU	IND	-	PWE	
Input area [hex]	1	3CB	00	00	0000	0000

Task success (WORD parameter) response

Step 5

Resetting the Option Board: To reset the Option Board, write a 2 followed by a 1 to Option Board parameter 972:

Table 45 Parameter Processing Message Area-Prepare Reset

		Change WORD parameter value task Parameter number 972				Write
Output area [hex]	2	3CC	00	00	0000	0002
Word offset		+0	+1	+2	+3	
Function	AK	PNU	IND	-	PWE	
Input area [hex]	1	3CC	00	00	0000	0000

Task success (WORD parameter) response

Without changing AK or PNU, set PWE=1

Table 46 Parameter Processing Message Area-Initiate Reset

		Change WORD parameter value task Parameter number 972				Write
Output area [hex]	2	3CC	00	00	0000	0001
Word offset		+0	+1	+2	+3	
Function	AK	PNU	IND	-	PWE	
Input area [hex]	7	3CC	00	00	0000	0011

Task failed (Parameter) response
Error: Not allowed due to operating state

The Option Board correctly executes the task and resets before responding. After the PROFIBUS master has re-connected, the Option Board tries to execute the task a second time. The task fails because parameter 972 may only be set to 1 if the current value is 2.

4-5-1-2 Accessing Inverter Parameters

When you address Inverter parameters, IND is used to select the parameter group.

Table 47 IND Values and Parameter Groups for Parameter Processing

Parameter	IND	Parameter	IND	Parameter	IND	Parameter	IND
A□□□	01h	C□□□	03h	F□□□	06h	P□□□	10h
b□□□	02h	d□□□	04h	H□□□	08h	U□□□	15h

PNU represents the parameter number in that group. To address P160 for example set IND=10h (P□□□) and PNU=0A0h (160).

Note It is important to use array tasks (6, 7 or 8) when accessing Inverter parameters. IND is only interpreted if the Option Board executes an array task.

The following example demonstrates how to use the parameter process message area to access Inverter Parameters:

Step 1

Reading an Inverter parameter: To read Inverter parameter P180 (PROFIBUS node address):

Table 48 Parameter Processing Message Area-Reading P180

Output area [hex]	6	0B4	10	00	0000	0000
Word offset	+0		+1		+2	+3
Function	AK	PNU	IND	-	PWE	
Input area [hex]	4	0B4	10	00	0000	0003

Read element value in array task
 Parameter number 180
 Parameter group P□□□

Task success (WORD element) response
 Read value: PROFIBUS node address

Step 2

Changing an Inverter parameter: To change Inverter parameter A001 (Frequency source) to 3 (Modbus):

Table 49 Parameter Processing Message Area-Changing A001

Output area [hex]	7	001	01	00	0000	0003
Word offset	+0		+1		+2	+3
Function	AK	PNU	IND	-	PWE	
Input area [hex]	4	001	01	00	0000	0000

Change WORD element value in array task
 Parameter number 1
 Parameter group A
 Write

Task success (WORD element) response

Step 3

Reading an Inverter parameter (DWORD): To read Inverter parameter F002 (Acceleration time 1):

Table 50 Parameter Processing Message Area-Reading F002

Output area [hex]	6	002	06	00	0000	0000
Word offset	+0		+1		+2	+3
Function	AK	PNU	IND	-	PWE	
Input area [hex]	5	002	06	00	0000	03E8

Read element value in array task
 Parameter number 2
 Parameter group F

Task success (DWORD element) response
 Read value: Acceleration time = 000003E8h = 1000 = 10.00 sec

Step 4

Changing an Inverter parameter (DWORD): To change Inverter parameter F002 (Acceleration time 1) to 3.00 sec:

Table 51 Parameter Processing Message Area-Changing F002

Write value: 3.00 sec = 300 = 0000012Ch

└─ Change DWORD element value in array task

└─ Parameter number 2

└─ Parameter group F□□□

Output area [hex]	8	002	06	00	0000	012C
Word offset		+0	+1	+2	+3	
Function	AK	PNU	IND	-	PWE	
Input area [hex]	5	002	06	00	0000	0000

└─ Task success (DWORD element) response

Caution Do not access Inverter parameters while the Inverter is being re-initialized.

MX2 Refer to the MX2 Inverter manual section 6-3.

RX Refer to the RX Inverter manual section 4-2.

Accessing parameters during a re-initialization will cause the Inverter to go into an undefined state.

4-5-2 PROFIdrive DP-V1 Parameter Channel

The Option Board provides Parameter Access in accordance with the PROFIdrive V4 profile definition. Access is only supported on DP-V1 Class 2 slot 0, index 47. You will therefore have to ensure that all MSAC2_Initialize, MSAC2_Write, MSAC2_Read and MSAC2_Abort messages make use of slot 0, index 47.

Note The OMRON web-site (<http://industrial.omron.eu>) provides function blocks that automate parameter access when using the CJ1W-PRM21 / CS1W-PRM21 version 3.0 or newer. These function blocks automate the DP-V1 Class 2 related commands to the PROFIBUS master as well as the DP-V1 parameter channel request and response formats. You can skip this section if you are using these function blocks.

Caution Do not access Inverter parameters while the Inverter is being re-initialized.

MX2 Refer to the MX2 Inverter manual section 6-3.

RX Refer to the RX Inverter manual section 4-2.

Accessing parameters during a re-initialization will cause the Inverter to go into an undefined state.

4-5-2-1 Opening and Closing a DP-V1 Channel

Before the PROFIBUS master can exchange information with the Option Board, the PROFIBUS master has to open a DP-V1 Class 2 (MSAC2) channel to the Option Board. Please consult the documentation of your PROFIBUS master on how to achieve this.

The Option Board only supports one DP-V1 Class 2 (MSAC2) channel. It is therefore advisable to close the channel when you are done. Not doing so will block other users of the parameter channel. Consult the documentation of your PROFIBUS master on how to achieve this.

4-5-2-2 DP-V1 read/write sequence

The following illustration demonstrates the DP-V1 read/write sequence.

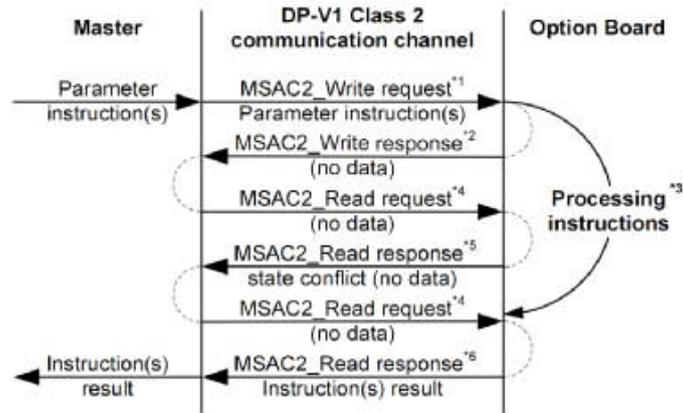

1. The PROFIBUS master generates an MSAC2_Write request with parameter instructions. The write instructs the Option Board to either read or change a number of parameters.
2. If the MSAC2_Write request is valid, the Option Board responds with a positive write response but no data. If the MSAC2_Write request is invalid, the Option Board responds with a DP error.
3. The Option Board starts processing and executing the parameter instructions:
 - While the Option Board is processing read instructions, it fills the result data with parameter values. If the Option Board encounters an error, the corresponding value is replaced with a PROFIdrive error number (Refer to section E-5 Parameter Value Formats).
 - While the Option Board is processing change instructions, it generally does not generate result data. However, if it encounters an error the result data is filled with either zero-data (no error) or the corresponding error value and element index (Refer to section E-5 Parameter Value Formats).
4. The master polls the Option Board with an MSAC2_Read request.
5. While the Option Board is busy executing the instructions, it responds with a negative read response (state conflict).
6. Once the Option Board is finished with the parameter instructions and the result is available, it responds with a positive read response, and the instruction result + data.

Note Consult the documentation of your PROFIBUS master to obtain information on how the above sequence may be automated.

4-5-2-3 Accessing Option Board Parameters

The following example demonstrates how to use the DP-V1 Class 2 (MSAC2) parameter channel to read an Option Board parameter:

Note It is outside the scope of this manual to explain the DP and DP-V1 headers and trailers. They are however shown in the illustrations to make the context of the message data visible.

Step 1

Open a DP-V1 Class 2 (MSAC2) channel to the Option Board (Refer to the documentation of your PROFIBUS master on how to open and close a DP-V1 channel)

Instruct the Option Board to read parameter 965 (Unit profile code):

Table 52 DP-V1 Class 2 Write-Parameter Read Instruction PNU965

Word offset		DP Header	MSAC2_Write	+0	+1	+2	+3	+4	DP Trailer		
Description				Request Header				Parameter Address			
Message data				REF	RT	DO	N	PA		CA	PNU
		[hex]		01	01	01	01	10	01	03C5	0000
		[dec]		1	1	1	1	16	0	965	0

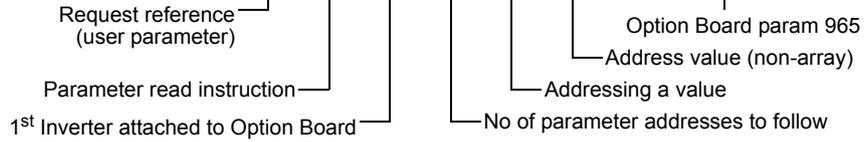

When the Option Board responds with the result, process the response:

Table 53 DP-V1 Class 2 Read-Result of PNU965 Read Instruction

Word offset		DP Header	MSAC2_Read	+0	+1	+2	+3	DP Trailer			
Description				Request Header					Value data		
Message data				REF	RT	DO	N		FMT	CV	DATA
		[hex]		01	01	01	01	42	01	0302	
		[dec]		1	1	1	1	66	0	770	

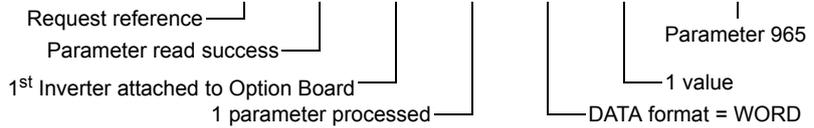

Step 2

Instruct the Option Board to read parameter elements 915.1 - 915.4 (Modbus addresses mapped into PZD1 - PZD4):

Table 54 DP-V1 Class 2 Write-Array Read Instruction PNU915.1-915.4

Word offset		DP Header	MSAC2_Write	+0	+1	+2	+3	+4	DP Trailer		
Description				Request Header				Parameter Address			
Message data				REF	RT	DO	N	PA		CA	PNU
		[hex]		02	01	01	01	10	04	0393	0001
		[dec]		2	1	1	1	16	4	915	1

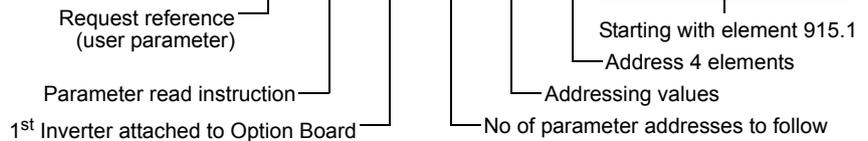

When the Option Board responds with the result, process the response:

Table 55 DP-V1 Class 2 Read-Result of PNU915.1-915.4 Read Instruction

Word offset		DP Header	MSAC2_Write	+0	+1	+2	+3	+4	+5	+6	DP Trailer		
Description				Request				Value data					
Message data				RE	RT	DO	N	FM	CV	DATA			
		[hex]		02	01	01	01	42	04	0000	0000	0000	0000
		[dec]		2	1	1	1	66	4	0	0	0	0

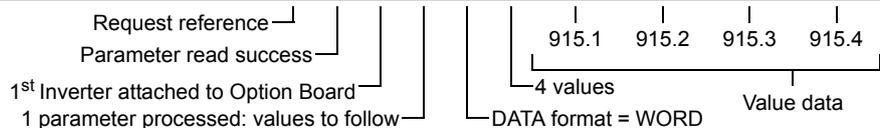

Step 3

Instruct the Option Board to change parameter elements 915.3 - 915.4 (Modbus address mapped into PZD3 - PZD4) to 1F01h (Coil data 0) and 1622h (P034 - Torque command level input):

Table 56 DP-V1 Class 2 Write-Array Change Instruction PNU915.3-915.4

Word offset		DP Header	MSAC2_Write	+0	+1	+2	+3	+4	+5	+6	+7	DP Trailer			
Description		DP Header	MSAC2_Write	Request		Parameter Address			Value data			DP Trailer			
				R	RT	D	N	PA	C	PNU	IND		F	C	DATA
Message data	[hex]			03	02	01	01	10	02	0393	0003	42	02	1F01	1622
	[dec]			3	2	1	1	16	2	915	3	66	2	7937	5666

When the Option Board responds with the result, process the response:

Table 57 DP-V1 Class 2 Read-Result of PNU915.3-915.4 Change Instruction

Word offset		DP Header	MSAC2_Read	+0	+1	DP Trailer		
Description		DP Header	MSAC2_Read	Request Header				DP Trailer
				REF	RT	DO	N	
Message data	[hex]			03	02	01	01	
	[dec]			3	2	1	1	

Step 4

Instruct the Option Board to change parameter 971 to 1 to (store changed parameter(s) in non-volatile memory):

Table 58 DP-V1 Class 2 Write-Parameter Change Instruction PNU971

Word offset		DP Header	MSAC2_Write	+0	+1	+2	+3	+4	+5	+6	DP Trailer			
Description		DP Header	MSAC2_Write	Request		Parameter Address			Value data			DP Trailer		
				RE	RT	DO	N	PA	CA	PNU	IND		FM	CV
Message data	[hex]			04	02	01	01	10	00	03CB	0000	42	01	0001
	[dec]			4	2	1	1	16	0	971	0	66	1	1

When the Option Board responds with the result, process the response:

Table 59 DP-V1 Class 2 Read-Result of PNU971 Change Instruction

Word offset		DP Header	MSAC2_Read	+0	+1	DP Trailer		
Description		DP Header	MSAC2_Read	Request Header				DP Trailer
				REF	RT	DO	N	
Message data	[hex]			04	02	01	01	
	[dec]			4	2	1	1	

Step 5 Instruct the Option Board to change parameter 972 first to 2, then to 1 (reset the Option Board):

Table 60 DP-V1 Class 2 Write-Multi-parameter Change Instruction PNU972

Word offset		DP Header	MSAC2_Write	+0		+1	
Description				Request Header			
Message data	[hex]			REF	RT	DO	N
	[dec]			05	02	01	02
		5	2	1	2		

Request reference
 Parameter change instruction
 2 parameter addresses and values to follow
 1st Inverter attached to Option Board

+2	+3	+4	+5	+6	+7	+8	+9	+10	+11	DP Trailer				
Parameter Address			Parameter Address				Value				Value			
PA	C	PNU	IND	PA	CA	PNU	IND	FMT	CV		DATA	FMT	CV	DATA
10	00	03CC	0000	10	00	03CC	0000	42	01		0002	42	01	0001
16	0	972	0	16	0	972	0	66	1	2	66	1	1	

Parameter 972 Value (non-array)
 Addressing a value
 Parameter 972 Value (non-array)
 Addressing a value
 1 value WORD format
 1 value WORD format
 1st parameter
 2nd parameter

If the Option Board responds with result data, the reset failed. When the Option Board is reset, the DP-V1 Class 2 (MSAC2) channel is automatically closed. The details of the change instruction are therefore lost.

Step 6 Re-open the DP-V1 Class 2 channel to the Option Board before continuing with further examples (Refer to section 4-5-2-1 *Opening and Closing a DP-V1 Channel*)

Note The DP-V1 Class 2 (MSAC2) channel parameter channel is automatically closed when resetting the Option Board. You will therefore have to re-open the channel before you can perform further parameter accesses.

4-5-2-4 Accessing Inverter Parameters

Step 7 Instruct the Option Board to read Inverter parameter P180 (PROFIBUS node address):

Table 61 DP-V1 Class 2 Write-Parameter Read Instruction P180

Word offset		DP Header	MSAC2_Write	+0	+1	+2	+3	+4	DP Trailer		
Description				Request Header				Parameter Address			
Message data				REF	RT	DO	N	PA		CA	PNU
		[hex]	06	01	01	01	10	00	3F34	0000	
		[dec]	6	1	1	1	16	0	16180	0	

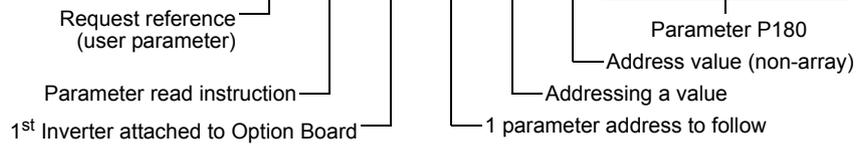

When the Option Board responds with the result, process the response

Table 62 DP-V1 Class 2 Read-Result of P180 Read Instruction

Word offset		DP Header	MSAC2_Read	+0	+1	+2	+3	DP Trailer			
Description				Request Header					Value		
Message data				REF	RT	DO	N		FMT	CV	DATA
		[hex]	06	01	01	01	42	01	0017		
		[dec]	6	1	1	1	66	1	23		

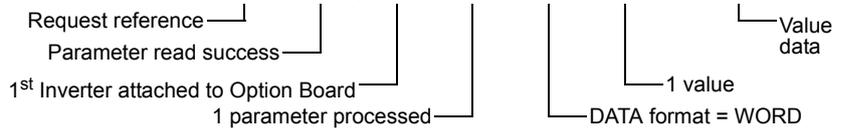

Step 8

Instruct the Option Board to change Inverter parameter A001 (Frequency source) to 3 (Modbus):

Table 63 DP-V1 Class 2 Write-Parameter Change Instruction A001

Word offset		DP Header	MSAC2_Write	+0	+1	+2	+3	+4	+5	+6	DP Trailer		
Description				Request				Parameter Address		Value data			
Message data				RE	RT	DO	N	PA	CA	PNU		IND	FM
		[hex]	07	02	01	01	10	00	03E9	0000	42	01	0003
		[dec]	7	2	1	1	16	0	1001	0	66	1	3

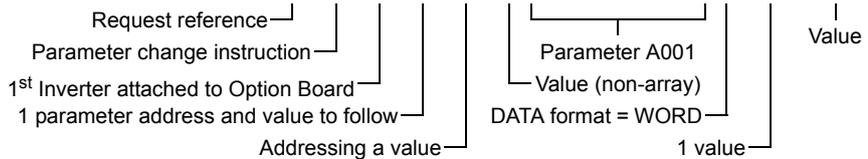

When the Option Board responds with the result, process the response:

Table 64 DP-V1 Class 2 Read-Result of A001 Change Instruction

Word offset		DP Header	MSAC2_Read	+0	+1	DP Trailer		
Description				Request Header				
Message data				REF	RT		DO	N
		[hex]	07	02	01	01		
		[dec]	7	2	1	1		



Step 9

Instruct the Option Board to read Inverter parameter F002 (Acceleration time 1):

Table 65 DP-V1 Class 2 Write-Parameter Read Instruction F002

Word offset		DP Header	MSAC2_Write	+0	+1	+2	+3	+4	DP Trailer		
Description				Request Header				Parameter Address			
Message data				REF	RT	DO	N	PA		CA	PNU
		[hex]	08	01	01	01	10	01	1772	0000	
		[dec]	8	1	1	1	16	0	6002	0	

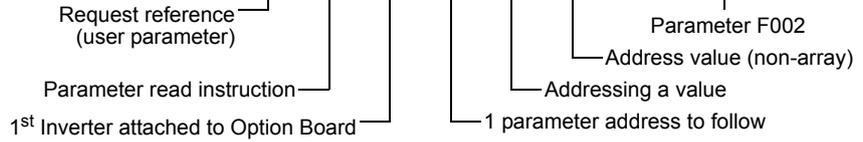

When the Option Board responds with the result, process the response:

Table 66 DP-V1 Class 2 Read-Result of F002 Read Instruction

Word offset		DP Header	MSAC2_Read	+0	+1	+2	+3	+4	DP Trailer		
Description				Request Header				Value			
Message data				REF	RT	DO	N	FMT		CV	DATA
		[hex]	08	01	01	01	42	01	0000	03E8	
		[dec]	8	1	1	1	66	1	1000		

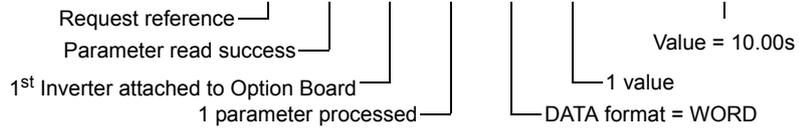

Step 10

Instruct the Option Board to change Inverter parameter F002 (Acceleration time 1) to 3.00 sec:

Table 67 DP-V1 Class 2 Write-Parameter Change Instruction F002

Word offset		DP Header	MSAC2_Write	+0	+1	+2	+3	+4	+5	+6	+7	DP Trailer			
Description				Request				Parameter Address			Value data				
Message data				R	RT	D	N	PA	C	PNU	IND		F	C	DATA
				[hex]	09	02	01	01	10	01	1771		0000	43	01
		[dec]	9	2	1	1	16	1	6001	0	67	1	300		

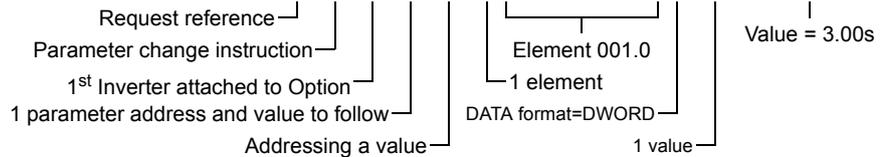

When the Option Board responds with the result, process the response:

Table 68 DP-V1 Class 2 Read-Result of F002 Change Instruction

Word offset		DP Header	MSAC2_Read	+0	+1	DP Trailer		
Description				Request Header				
Message data				REF	RT		DO	N
		[hex]	09	02	01	01		
		[dec]	9	2	1	1		



Step 11

Close the DP-V1 Class 2 (MSAC2) channel (Refer to section 4-5-2-1 Opening and Closing a DP-V1 Channel)

4-5-2-5 Processing an Error Response

When the Option Board is unable to execute one of the read parameter instructions, it adds an error value to the result data. Reading parameters A001, A166 and P033 for example:

Table 69 DP-V1 Class 2 Write-Parameter Read Instruction Bad Parameter

Word offset			+0	+1		
Description	DP Header	MSAC2_Write	Request Header			
			REF	RT	DO	N
Message data	[hex]		0A	01	01	03
	[dec]		10	1	1	3

Request reference
 Parameter read instruction
 3 parameters address to follow
 1st Inverter attached to Option Board

	+2	+3	+4	+5	+6	+7	+8	+9	+10	DP Trailer			
	Parameter Address			Parameter Address				Parameter Address					
	PA	CA	PNU	IND	PA	CA	PNU	IND	PA		CA	PNU	IND
	10	00	03E9	0000	10	00	048E	0000	10		00	3EA1	0000
	16	0	1001	0	16	0	1166	0	16	0	16033	0	

Parameter A001
 Non-array
 Addressing a value
 Parameter A166
 Non-array
 Addressing a value
 Parameter P033
 Non-array
 Addressing a value

Has the following result:

Table 70 DP-V1 Class 2 Read-Result of Read Instruction on Bad Parameter

Word offset			+0	+1		
Description	DP Header	MSAC2_Read	Request Header			
			REF	RT	DO	N
Message data	[hex]		0A	81	01	03
	[dec]		10	129	1	3

Request reference
 Parameter read error
 3 error values to follow
 1st Inverter attached to Option Board

	+2	+3	+4	+5	+6	+7	DP Trailer			
	Value		Value			Value				
	FMT	CV	DATA	FMT	CV	DATA		FMT	CV	DATA
	42	01	0004	44	01	0000		42	01	0302
	66	1	4	68	1	0	66	1	770	

DATA format = WORD
 DATA format = Error no
 1 value
 DATA format = WORD
 Bad parameter number
 A001
 A166
 P033

Note that the value of parameter A166 is replaced with an error value in the result data. Inverter parameter A166 does not exist, so error number 0000h (Bad parameter number) is returned. Note that the values of A001 and P033 are returned irrespective of other read errors.

Note If a read on one of the elements in an array fails, an error is returned on the parameter. Successfully read elements can therefore not be returned.

When the Option Board is unable to execute one of the write parameter instructions, it adds an error value and the failed element index to the result data. Changing Option Board parameter elements 915.9 - 915.12 for example:

Table 71 DP-V1 Class 2 Write-Parameter Change Instruction Bad Parameter

Word offset		DP Header MSAC2_Write	+0	+1	+2	+3	+4		
Description			Request Header				Parameter Address		
Message data			REF	RT	DO	N	PA	CA	PNU
[hex]		0B	02	01	01	10	04	0393	0009
[dec]		11	2	1	1	16	4	915	9

Word offset		DP Header MSAC2_Read	+5	+6	+7	+8	+9	
Description			Value data					
Message data			FMT	CV	DATA			
[hex]		42	04	0000	0000	0000	0000	
[dec]		66	4	0	0	0	0	

Request reference
 Parameter change instruction
 1st Inverter attached to Option Board
 1 parameter address and value to follow
 4 elements
 Addressing values
 Start element 915.9
 DATA format = WORDs
 4 values
 Value data
 DP Trailer

Has the following result:

Table 72 DP-V1 Class 2 Read-Result of Change Instruction on Bad Parameter

Word offset		DP Header MSAC2_Read	+0	+1	+2	+3	+4		
Description			Request Header				Values		
Message data			REF	RT	DO	N	FMT	CV	DATA
[hex]		0B	82	01	01	44	02	0003	000B
[dec]		11	130	1	1	68	2	3	11

Request reference
 Parameter change error
 1st Inverter attached to Option Board
 1 error value to follow
 2 values
 DATA format = Error no
 Failed
 Error no: Faulty
 DP Trailer

Note that the error number is followed by the element number where the change instruction failed. I.e. The changes to Option Board parameter elements 915.9 and 915.10 were carried out successfully. The attempt to change 915.11 failed and changes to subsequent elements (915.12) were not carried out.

4-6 Flexible Mode

The Flexible device profile lets you operate the Inverter using the Modbus registers directly. Parameters P160 - P169 and P170 - P179 can be used to map Modbus registers into the cyclically exchanged process areas. User parameters P160 - P169 configure the output process area mappings where parameters P170 - P179 configure the input process area mappings.

4-6-1 Typical Configuration

Step 1

Configure the Option Board and Network as explained in sections 3-1 *Configuring the Option Board* and 3-2 *Configuring the Network*, but limit the following choices:

- When selecting the device profile when configuring the Option Board (Step 1 of section 3-1 Configuring the Option Board), select the Flexible device profile by setting P182 to 2.
- When choosing the module while configuring the network (Step 6 of section 3-2 Configuring the Network), select the Flexible module.

- Step 2** Set parameters P160 to 1F01h to map coil data 0 as the 1st word into the output process area.
- Step 3** Set parameters P161 and P162 to 0001h and 0002h to map the Modbus frequency reference (F001) as the 2nd and 3rd words in the output process area.
- Step 4** Set parameter P170 to 0003h to map Inverter status A as the 1st word in the input process area.
- Step 5** Set parameter P171 to 1E01h to map coil data 1 (coil no 0010h to 001Fh) into the 2nd word in the input process area.
- Step 6** Set parameters P172 and P173 to 1001h and 1002h to map the Modbus frequency monitor (d001) as the 3rd and 4th words in the input process area.
- Step 7** Restart the Inverter or reset the Option Board for the new settings to take effect.

If you configured everything correctly, your output and input process areas should have the following mapping:

Table 73 Flex Mode Output Area with Typical Configuration

Word offset	+0	+1	+2	+3	+4	+5	+6	+7	+8	+9
Register	Coil data 0	F001 (0001h/0002h)	-	-	-	-	-	-	-	-
Value	dec	0	0	0	0	0	0	0	0	0
	hex	0000	0000	0000	0000	0000	0000	0000	0000	0000

Bit	15	14	13	12	11	10	9	8	7	6	5	4	3	2	1	0
Name	-	In8 ^{RX}	In7	In6	In5	In4	In3	In2	In1	-	-	RS	EXT	Dir	Opr	-
Value	0	0	0	0	0	0	0	0	0	0	0	0	0	0	0	0

- Opr Operation command
- Dir Rotation direction command
- EXT External Trip
- RS Trip reset
- In1 Intelligent input terminal [1]
- In2 Intelligent input terminal [2]
- In3 Intelligent input terminal [3]
- In4 Intelligent input terminal [4]
- In5 Intelligent input terminal [5]
- In6 Intelligent input terminal [6]
- In7 Intelligent input terminal [7]
- In8^{RX} Intelligent input terminal [8]

RX

Note The operation status coil (000Fh) cannot be used in the output process area because it is not writeable.

Table 74 Flex Mode Input Area with Typical Configuration

Word offset	+0	+1	+2	+3	+4	+5	+6	+7	+8	+9
Register	Invstat A	Coil data 1	d001 (1001h/1002h)	-	-	-	-	-	-	-
Value	dec	2	0	0	0	0	0	0	0	0
	hex	0002	0002	0000	0000	0000	0000	0000	0000	0000

Bit	15	14	13	12	11	10	9	8	7	6	5	4	3	2	1	0
Name	ONT	RNT	TRQ	UV	IP ^{RX}	OTQ	FA3	AL	OD	OL	FA2	FA1	RUN	-	Rdy	Dir
Value	0	0	0	0	0	0	0	0	0	0	0	0	0	0	1	0

- Dir Rotation direction
- Rdy Inverter ready
- RUN Running
- FA1 Constant-speed reached
- FA2 Set frequency overreached
- OL Overload advance notice
- OD Output deviation for PID control
- IP^{RX} IP during momentary power interruption. Is only applicable for the RX Inverter,
- AL Alarm signal
- FA3 Set frequency reached
- OTQ Over-torque
- UV Undervoltage
- TRQ Torque limited
- RNT Operation time over
- ONT Plug-in time over
- Invstat A (Refer to Inverter MX-2 Manual section B-4-2) (Refer to Inverter RX Manual section 4-4 Communication Function)

RX

⚠ WARNING

MX2

A revision AAAA MX2 Inverter allows the motor to run immediately if a trip condition is reset, and at the same time, Opr (Coil data 0) is set. For safe operation clear Opr (Coil data 0) when you detect that InvStat A changes to 8. Refer to section 1-1-2 Inverter Support to determine the MX2 Inverter revision.

4-6-2 Operating the Motor

Step 8 Set A001=3 and A002=3 so that the Inverter can be controlled using the Modbus registers.

Step 9 Set the Opr bit to put the Inverter in run mode. The RUN indicator on the Inverter should light up at this point. If this is not the case, check your source selection.

Step 10 Change d001 to the desired frequency (E.g. 1000 for 10.00 Hz)

Table 75 Flex Mode Output Area with Motor Running Forward

Word offset	+0	+1	+2	+3	+4	+5	+6	+7	+8	+9
Register	Coil data 0	F001 (0001h/0002h)	-	-	-	-	-	-	-	-
Value	dec	2	+1000	0	0	0	0	0	0	0
	hex	0002	0000	03E8	0000	0000	0000	0000	0000	0000

Bit	15	14	13	12	11	10	9	8	7	6	5	4	3	2	1	0
Name	- ¹	In8 ^{*RX}	In7	In6	In5	In4	In3	In2	In1	-	-	RS	EXT	Dir	Opr	-
Value	0	0	0	0	0	0	0	0	0	0	0	0	0	0	1	0

In8^{*RX} : Is only applicable for the RX Inverter

RX

The motor accelerates until it reaches the desired frequency. Notice that the FA1 bit is set once the inverter has reached the desired reference frequency.

Table 76 Flex Mode Input Area with Motor Running Forward

Word offset	+0	+1	+2	+3	+4	+5	+6	+7	+8	+9
Register	Invstat A	Coil data 1	d001 (1001h/1002h)	-	-	-	-	-	-	-
Value	dec	3	26	+1000	0	0	0	0	0	0
	hex	0003	001A	0000	03E8	0000	0000	0000	0000	0000

Bit	15	14	13	12	11	10	9	8	7	6	5	4	3	2	1	0
Name	ONT	RNT	TRQ	UV	IP ^{*RX}	OTQ	FA3	AL	OD	OL	FA2	FA1	RUN	-	Rdy	Dir
Value	0	0	0	0	0	0	0	0	0	0	0	1	1	0	1	0

IP^{*RX} : Is only applicable for the RX Inverter

Step 11 **RX** Set Dir to reverse the direction of the motor. The motor decelerates, stops and then accelerates in the opposite direction. The FA1 bit clears as soon as the reference frequency is changed. When the motor starts reversing, the Dir bit in Coil data 1 is set. Once the new reference frequency is reached, the FA1 bit is once again set.

Step 12 Clear the Opr bit to stop the motor. The motor decelerates and comes to a halt.

4-6-3 Faults and Trips

User trips can be generated by setting the EXT bit in coil data 0. You must always immediately clear the Opr bit in your PLC program when the AL bit in Coil Data 1 (Tripping) is set by the inverter. If the Opr bit is set when the trip condition is cleared, the Inverter will immediately start running!

⚠ WARNING

Always clear the Opr bit in your PLC program when Inverter status A is set to 8 (Tripping) by the Inverter. Not doing so may result in the motor starting unexpectedly when the trip is cleared.
Set and clear the RS bit in coil data 0 to clear a trip.

⚠ WARNING

Always clear the RS bit after setting it. Not doing so will result in new trip conditions automatically being cleared.

4-6-4 Mapping Restrictions

The Flexible device profile places the same mapping restrictions on your configuration as explained for the PROFIdrive device profile (Refer to section 4-3-4 *Mapping Restrictions*).

4-7 Limitations Caused by Inverter Mode and Rating Selection

MX2 The Inverter mode and rating selection directly affects several aspects of the Option Board usage. (Refer to the MX2 Inverter user's manual section 3-6-24). The following table lists the most common consequences of the various Inverter modes and ratings:

Table 77 Limitations Caused by Inverter Mode and Rating Selection MX2

Inverter Mode and Rating	Standard Induction		High Frequency	Permanent Magnet
	Constant Torque	Variable Torque		
d060	0 (1-C)	1 (1-v)	2 (H-1)	3 (P)
HSW and HIW scaling	0.01 Hz		0.1 Hz	0.01 Hz
Torque-related registers	Available	Not available* ¹		

Note The Inverter will trip due to a cyclic mapping fault if you use torque-related registers in the process area when not available.

RX The Inverter mode and rating selection directly affects several aspects of the Option Board usage. (Refer to the RX Inverter User Manual section 4-2). The following table lists the most common consequences of the various Inverter modes and ratings:

Table 78 Limitations Caused by Inverter Mode and Rating Selection RX

Inverter Mode and Rating	Standard Induction Motor	
	Constant Torque	Variable Torque
d060	0 (1-C)	1 (1-v)
HSW and HIW scaling	0.01 Hz	
Torque-related registers	Available	Not available* ¹

Note The Inverter will trip due to a cyclic mapping fault if you use torque-related registers in the process area when not available.

SECTION 5

Troubleshooting and Maintenance

5-1 Troubleshooting using the LED indicators

The four LED indicators on the Option Board provide information on the Option Board mode and status and the network status.

When an error occurs, the Option Board indicator pattern provides troubleshooting information. For certain errors, additional information can be obtained from the trip error code given by the four-digit display of the Inverter.

In the following sections typical LED indicator and four-digit Inverter display patterns are provided to assist in troubleshooting. To show the status of the indicators, the following conventions are used:

- RUN OFF
- RUN ON
- V
 RUN Flashing
- RUN Not important (Ignore)
- E6Q ! Inverter error code
- 000 Not important (Ignore)

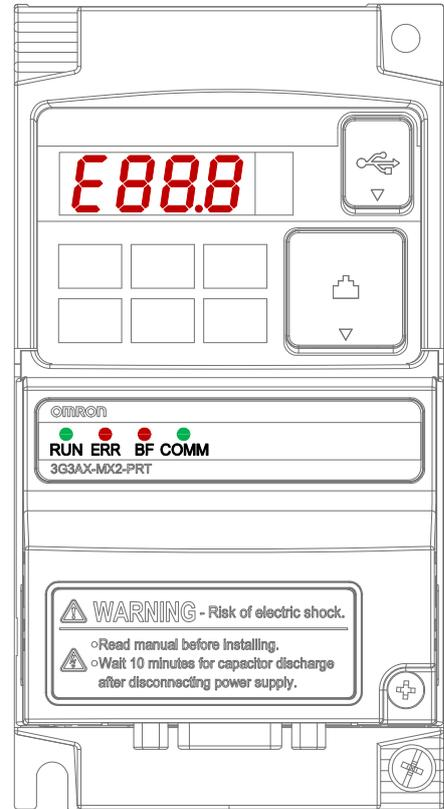

5-1-1 When an error occurs

When an error occurs, the Option Board trips the Inverter.

Step 1 MX2 For the MX2 Inverter, an error code is displayed on the Digital Operator Display.

RX For the RX Inverter, you need to connect the Digital Operator Display to the Inverter with an Ethernet cable. Then you can see the error code on the display. Note: if despite the problem it is still possible to communicate with the unit, the latest error code can also be read in parameter d081.

Step 2 Use the error code to help troubleshoot the error.

In the following sections typical LED indicator and four-digit Inverter display patterns are provided to assist in troubleshooting. To show the status of the indicators, the following conventions are used:

- MS OFF
- MS RED
- MS GREEN
- V
 MS Flashing
- MS Not important (Ignore)
- E6Q ! Inverter error code
- 000 Not important (Ignore)

Tip Do not clear the trip before you are finished troubleshooting an error. When you clear the trip, the error code is cleared from the four-digit display. The trip history can however be read back using d080 through d086. This will allow you to diagnose the error even if you accidentally cleared the trip cause.

5-1-2 Option board or inverter errors



During the Initialization process the RUN indicator will remain OFF. Once the initialization has been completed correctly, the RUN indicator will be ON and the ERR indicator OFF. The table below shows the indicator and display patterns caused by Option Board or Inverter Errors.

Table 79 Option board or inverter errors

MX2 Display & Indicators	RX Display & Indicators	Possible Cause(s)	Corrective Action
		The Inverter does not power up.	MX2 Follow the instruction provided in the MX2-Inverter user's manual section 6-1-4 to troubleshoot. RX Follow the instruction provided in the RX-Inverter user's manual section 6-1 to troubleshoot.
		The Option Board is not mounted properly.	Check that the Option Board is mounted properly and restart the Inverter.
		The Option Board connector is damaged.	Replace the Option Board.
		The Inverter RS input is ON.	Switch the Inverter RS input OFF.
		The Option Board encountered a fatal error during Operation.	Check that the Option Board is mounted properly and restart the Option Board. If the problem persists, replace the Option Board.
		The Inverter does not support an Option Board (Refer to 1-1-2 Inverter Support)	Replace the Inverter.
		The Option Board connector is damaged	Replace the Option Board.
		The Inverter encountered a fatal error during Operation.	Restart the Inverter. If the problem persists, replace the Inverter.
		MX2 The Option Board node address was set using the set-slave address functionality of your PROFIBUS master or diagnostic tool, but the Inverter password function is set.	MX2 Restart the Option Board. If you need to set the Option Board node address, first clear the Inverter password (Refer to section 3-6-25 in the MX2 Inverter user's manual).
		The user program requested a trip by setting the external trip bit of the conventional module operation command.	Check and correct all items in accordance with the user program.

5-1-3 Configuration Errors



If the Option Board is correctly configured, the RUN indicator will be ON and the ERR indicator OFF. The table below shows the indicator and display patterns caused by configuration errors.

Table 80 Configuration Errors

MX2 Display & Indicators	RX Display & Indicators	Possible Cause(s)	Corrective Action
		One of the configuration parameters P160 - P179 has been rejected by the Inverter.	<p>Check (and correct) the following items:</p> <ul style="list-style-type: none"> • Is one of the parameters P160 - P179 specifying a Modbus register that does not exist? • If one of the parameters P160 - P169 is specifying a double-word Modbus register: Are both the high- and low-words specified in sequence by two consecutive parameters? • If one of the parameters P170 - P179 is specifying a double-word Modbus register: Are both the high- and low-words specified in sequence by two consecutive parameters? • Is a Modbus register specified twice in the output parameter registers P160 - P169? • Is one of the output parameters P160 - P169 specifying a Modbus register that is read only? (A register is read-only if it has an 'R' in the 'R/W' column). <p>MX2 See section B-4-2 of the MX2 Inverter user's manual.</p> <p>RX See section 4-4 Register Number List RX Inverter user's manual.</p> <ul style="list-style-type: none"> • Is one of the output parameters P160 - P169 specifying a Modbus register of which the parameter is not run-mode editable? <p>MX2 Refer to section 3-2-3 of the MX2 Inverter user's manual.</p> <p>RX Refer to Appendix 1 of the RX-Inverter user's manual.</p>
		Your Inverter version has not been properly verified with this version of the Option Board (The PROFIBUS node address in the Inverter is invalid or absent).	Reset the Inverter to factory defaults. If the problem persists, contact your local OMRON representative for assistance.
		Your Inverter version has not been properly verified with this version of the Option Board (Some Option Board parameters in the Inverter are invalid or absent).	Reset the Inverter to factory defaults. If the problem persists, contact your local OMRON representative for assistance.

5-1-4 PROFIBUS Errors



If the PROFIBUS master is correctly configured and there are no wiring errors, the COMM indicator will be ON and the BF indicator OFF. The table below shows the indicator patterns caused by configuration PROFIBUS errors.

Table 81 PROFIBUS Errors

MX2 Display & Indicators	RX Display & Indicators	Possible Cause(s)	Corrective Action
<p>The diagram shows four indicator lights labeled RUN, ERR, BF, and COMM. Above them is a digital display showing '0.00'. The RUN light is lit (grey), ERR is lit (red), BF is unlit (white), and COMM is lit (green).</p>		The PROFIBUS master cannot communicate with the Option Board because the PROFIBUS configuration is not correct.	Check (and correct) the following items: <ul style="list-style-type: none"> • Does the node address in your PROFIBUS master configuration program match P180? • Does any other slave device on the PROFIBUS network also have the same node address? • Is the PROFIBUS master ON-LINE? • If you are using OMRON CX-Configurator: Make sure that the 'Enable DPV1 option' on the 'DPV1' tab is NOT checked.
		The PROFIBUS wiring is not correct.	Check (and correct) the following items: <ul style="list-style-type: none"> • Are the correct pins wired on the PROFIBUS connector? • Are there any short circuits or line interruptions? • Are you using the correct cable type? • If you have branches from the PROFIBUS cable main line: Are any of these branches too long?
		The PROFIBUS network has not been terminated correctly.	Follow the instruction provided in the PROFIBUS Installation Guideline for Cabling and Assembly to correctly terminate the network.
		The Option Board detected too many communication errors.	Check (and correct) the following items: <ul style="list-style-type: none"> • Is the ground cable of the Option Board connected to a ground terminal on the Inverter? MX2 Are the MX2 installation guidelines to comply with EMC recommendations properly implemented (refer to MX2 User's manual section D-1)? RX Are the RX installation guidelines to comply with EMC recommendations properly implemented (refer to RX User's manual section "2-1 Installation")? • Are there any excessive EMI sources near any of the cables or equipment?

Table 81 PROFIBUS Errors (continued)

MX2 Display & Indicators	RX Display & Indicators	Possible Cause(s)	Corrective Action
		The PROFIBUS configuration is NOT correct, but the PROFIBUS master can communicate with the Option Board.	Check (and correct) the following items: <ul style="list-style-type: none"> • Does the node address of any OTHER slave device on the PROFIBUS network match P180? • Are you using the correct GSD file in your PROFIBUS master configuration program? • Does the device profile (P182) support the configured module in your PROFIBUS master configuration program (Refer to 3-1 Configuring the Option Board)?
		The network error action (selected with parameter P045) was executed due to a PROFIBUS network error.	Check (and correct) the following items: <ul style="list-style-type: none"> • Is the PROFIBUS master faulty, switched off or off-line? • Are the PROFIBUS connectors on both the Option Board and master properly connected? • Has anything changed on the PROFIBUS network (devices, termination, connectors, etc.)? • Are there any short circuits or line interruptions?

5-1-5 Commissioning Mode



If the Option Board is operating in commissioning mode, the RUN indicator will flash.

Commissioning mode is NOT an error, but it can influence normal system operation. During commissioning mode, Inverter parameter access takes priority over cyclic data exchange. Accessing Inverter parameters will therefore delay cyclic data exchange causing unexpected latencies.

If you are not busy configuring the Option Board or drive parameters, disable commissioning mode by writing a 0 (zero) to PNU890.

Caution Make sure that you disable commissioning mode before operating the system.

5-2 Troubleshooting Using PROFIBUS Diagnostics

The Option Board provides PROFIBUS slave diagnostics when used in combination with a PROFIBUS master configuration program (or similar). The Option Board supports all the pre-defined PROFIBUS diagnostics data. Some additional (extended) diagnostic data is added to provide you with extensive means to troubleshoot errors in the Option Board, Inverter and/or network.

Note A properly implemented PROFIBUS master configuration program should be able to automatically interpret the diagnostic messages generated by the Option Board using the GSD file. If for some reason you have to manually interpret the diagnostic messages, refer to Appendix H.

5-2-1 Standard Diagnostic Information

Table 82 Standard diagnostic information

Diagnostic Status	Possible Cause(s)	Corrective Action
Master lock	If you are not in data exchange with the Option Board: Another PROFIBUS master on the network is in data exchange with the Option Board.	<ul style="list-style-type: none"> Remove the other PROFIBUS master from the network. Remove the Option Board from the configuration of the other PROFIBUS master.
Parameter fault	The parameter data sent by the PROFIBUS master has been rejected by the Option Board.	Check (and correct) the following items: <ul style="list-style-type: none"> Does the node address of any OTHER slave device on the PROFIBUS network match P180? Are you using the correct GSD file in your PROFIBUS master configuration program? If you are using OMRON CX-Configurator: Is the 'Enable DPV1 option' on the 'DPV1' tab checked?
Invalid slave response	The PROFIBUS master is not compatible with the specification of the Option Board.	Check (and correct) the following items: <ul style="list-style-type: none"> Is the PROFIBUS master compatible with the specification of the Option Board? Are there any intermittent cable faults?
	The PROFIBUS wiring is not correct.	Check (and correct) the following items: <ul style="list-style-type: none"> Are there any intermittent short circuits or line interruptions? Are you using the correct cable type? If you have branches from the PROFIBUS cable main line: Are any of these branches too long?
	The PROFIBUS network has not been terminated correctly.	Follow the instruction provided in the PROFIBUS Installation Guideline for Cabling and Assembly to correctly terminate the network.
Function not supported	The PROFIBUS master has sent an unsupported message to the Option Board.	Check (and correct) the following items: <ul style="list-style-type: none"> Is the PROFIBUS master configured to send messages that are not supported by the Option Board? Is the PROFIBUS master compatible with the specification of the Option Board?
Extended Diagnostics	The Option Board has sent extended diagnostic information.	Use your PROFIBUS master configuration program to read the extended diagnostic information. Refer to section 5-2-2 for further troubleshooting.
Configuration fault	The selected device profile (P182) does not support the configured module in your PROFIBUS master configuration program (Refer to section 3-1).	<ul style="list-style-type: none"> Change the device profile to support the selected module in the PROFIBUS master configuration program. Selected a module in the PROFIBUS master configuration program that is supported by the selected device profile.

Table 82 Standard diagnostic information (continued)

Diagnostic Status	Possible Cause(s)	Corrective Action
Station not ready	The Option Board is still starting up.	If the problem persists, replace the Option Board.
Station not existent	The PROFIBUS wiring is not correct.	Check (and correct) the following items: <ul style="list-style-type: none"> • Are the correct pins wired on the PROFIBUS connector? • Are there any short circuits or line interruptions? • Are you using the correct cable type? • If you have branches from the PROFIBUS cable main line: Are any of these branches too long?
	The PROFIBUS network has not been terminated correctly.	Follow the instruction provided in the PROFIBUS Installation Guideline for Cabling and Assembly to correctly terminate the network.
Slave deactivated	The Option Board has been deactivated as slave in the PROFIBUS master	Activate the Option Board as slave in the PROFIBUS master.
Sync Mode	The Option Board has been set to SYNC mode using a global command.	If the Option Board was not intentionally put in sync mode: <ul style="list-style-type: none"> • Restart the Option Board, or • Use the PROFIBUS master to send an UNSYNC command to the Option Board.
Freeze Mode	The Option Board has been set to FREEZE mode using a global command.	If the Option Board was not intentionally put in freeze mode <ul style="list-style-type: none"> • Restart the Option Board, or • Use the PROFIBUS master to send an UNFREEZE command to the Option Board.
Watchdog on	If OFF: The Option Board network watchdog is disabled in the PROFIBUS master configuration program.	If the Option Board network watchdog is not intentionally disabled, enable it using the PROFIBUS master configuration program.
Parameter request	A parameter fault occurred or a configuration check failed.	Refer to the Parameter fault or Configuration check diagnostic statuses to troubleshoot.

5-2-2 Extended Diagnostic Information

Table 83 Extended diagnostic information

Diagnostic Status	Possible Cause(s)	Corrective Action
AC power failure	The Inverter is not detecting any AC mains supply voltage.	<ul style="list-style-type: none"> • Check the AC mains supply voltage. <p>MX2 Follow the instruction provided in the MX2 Inverter user's manual section 6-1-4 to troubleshoot.</p> <p>RX Follow the instruction provided in the RX Inverter user's manual section 6-1 to troubleshoot.</p>
	The Inverter's fuse is blown.	Replace the Inverter fuse.
Inverter communication error	The Inverter encountered a fatal error during Operation.	Restart the Inverter. If the problem persists, replace the Inverter.

Table 83 Extended diagnostic information (continued)

Diagnostic Status	Possible Cause(s)	Corrective Action
Mapped output register rejected	One of the output configuration parameters P160 - P169 has been rejected by the Inverter.	<p>Check (and correct) the following items:</p> <ul style="list-style-type: none"> • Is one of the parameters P160 - P169 specifying a Modbus register that does not exist? • Is a Modbus register specified twice in the output parameter registers P160 - P169? • If one of the parameters P160 - P169 is specifying a double-word Modbus register: Are both the high- and low-words specified in sequence by two consecutive parameters? • Is one of the output parameters P160 - P169 specifying a Modbus register that is read only? (A register is read-only if it has an 'R' in the 'R/W' column) <p>MX2 See in section B-4-2 of the MX2 Inverter user's manual.</p> <p>RX See in section "4-4 Register Number List" of the RX Inverter user's manual.</p> <ul style="list-style-type: none"> • Is one of the output parameters P160 - P169 specifying a Modbus register of which the parameter is not run-mode editable? <p>MX2 Refer to section 3-2-3 of the MX2-A□ Inverter user's manual.</p> <p>RX Refer to Appendix 1 of the RX Inverter user's manual.</p>
Mapped input register rejected	One of the input configuration parameters P170 - P179 specifying a Modbus register that does not exist.	<p>Check (and correct) the following items:</p> <ul style="list-style-type: none"> • Is one of the parameters P170 - P179 specifying a Modbus register that does not exist? • If one of the parameters P170 - P179 is specifying a double-word Modbus register: Are both the high- and low-words specified in sequence by two consecutive parameters?
Node storage failed	Your Inverter version has not been properly verified with this version of the Inverter.	Contact your local OMRON representative for assistance.
Invalid option parameters	Your Inverter version has not been properly verified with this version of the Inverter.	Contact your local OMRON representative for assistance.
Commissioning mode is active	Commissioning mode is NOT an error, but it can influence normal system operation. During commissioning mode, Inverter parameter access takes priority over cyclic data exchange. Accessing Inverter parameters will therefore delay cyclic data exchange causing unexpected latencies.	If you are not busy configuring the Option Board or drive parameters, disable commissioning mode by writing a 0 (zero) to PNU890.

5-3 Maintenance and Inspection

5-3-1 How to replace the MX2 Option Board

⚠ HIGH VOLTAGE Always Switch OFF the mains power supply to the Inverter before removing the Option Board. Wait for the time specified on the Inverter front cover for the capacitors to discharge. Not doing so may result in electrical shock.

Step 1 **MX2** Loosen the faulty Option Board mounting screw.

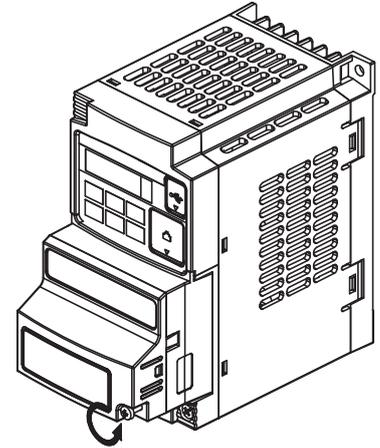

Step 2 **MX2** Pull the faulty Option Board straight out of the Inverter while pushing down on the indicated sides to release the snap-fits.

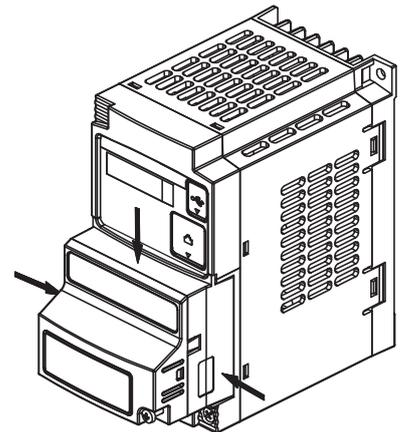

Step 3 **MX2** For Inverters up to 4.0 kW only: loosen the screw(s) of the terminal block cover and remove the cover to enable access to the chassis ground terminal screws.

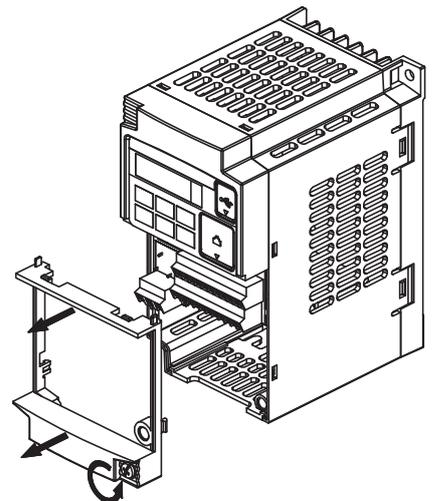

Step 4

MX2 Unscrew and remove the faulty Option Board grounding cable. Keep the screw and washers, but set the faulty Option Board aside.

1-phase 200 V 0.1 - 2.2 kW
 3-phase 200 V 0.1 - 3.7 kW
 3-phase 400 V 0.4 - 4.0 kW

3-phase 200 V 5.5 - 15 kW
 3-phase 400 V 5.5 - 15 kW

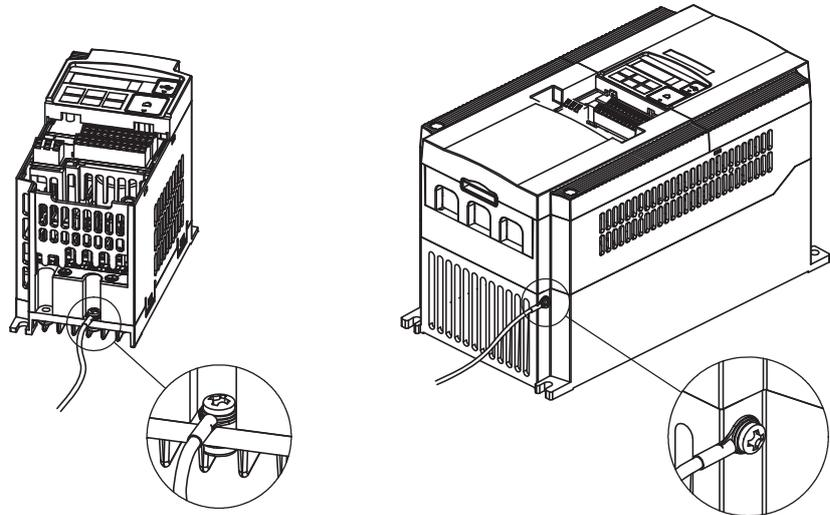

Step 5

MX2 Secure the replacement Option Board grounding cable to the Inverter using the mounting screw.

Unscrew and remove the faulty Option Board grounding cable.
 Keep the screw and washers, but set the faulty Option Board aside.

Step 6

MX2 If removed in Step 3, mount the terminal cover again and tighten the screw(s).

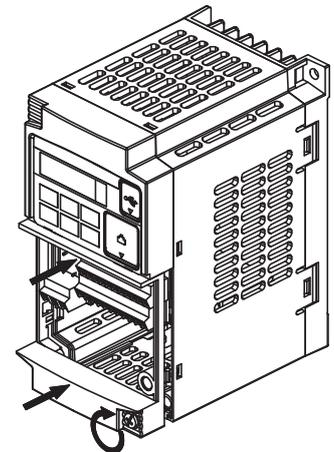

Step 7

MX2 Push the replacement Option Board into Inverter to replace the removed Option Board until it clicks into place

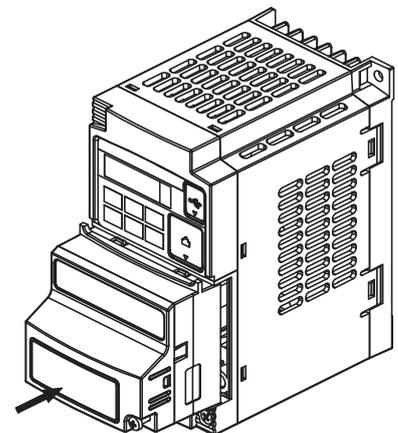

Step 8

MX2 Press down on the indicated corner of the replacement Option Board housing to ensure proper connection of the Option Board connector

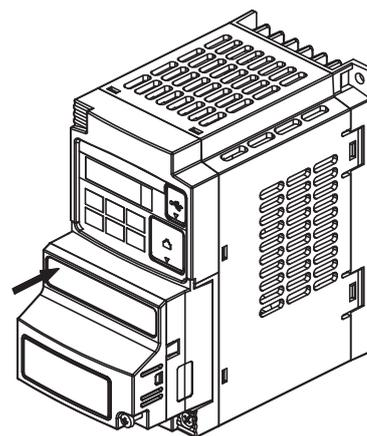

Step 9

MX2 Check that there is no gap between the top edges of the replacement Option Board and the Inverter casing.

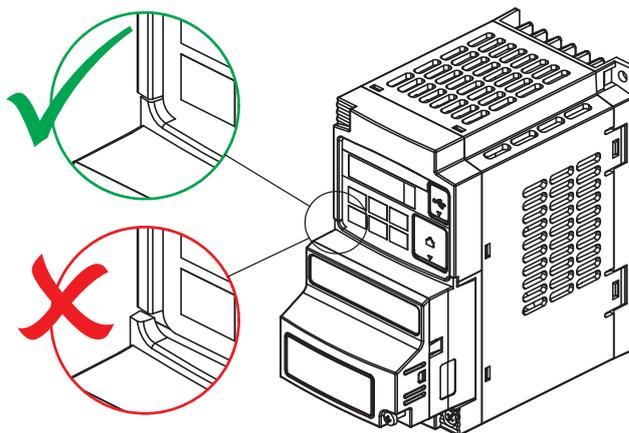

Step 10

MX2 Secure the replacement Option Board in place with the mounting screw (do not over-tighten).

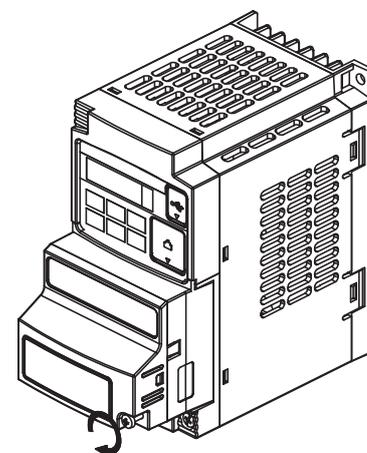

⚠ Caution When replacing an Inverter be sure that all Inverter settings of the Inverter being replaced are restored to the replacement.

5-3-2 How to replace the RX Option Board

⚠ HIGH VOLTAGE Always Switch OFF the mains power supply to the Inverter before removing the Option Board. Wait for the time specified on the Inverter front cover for the capacitors to discharge. Not doing so may result in electrical shock.

Step 1 **RX** Remove the blind cover by pushing the lip on the top

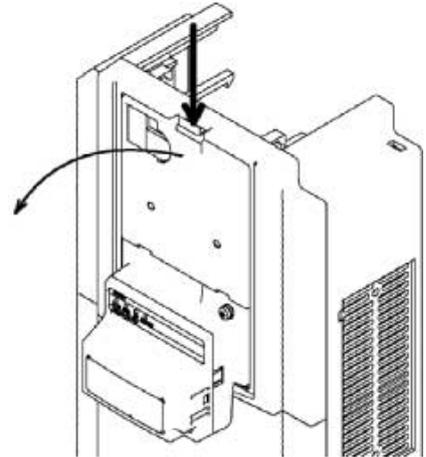

Step 2 **RX** Unscrew the screw on the top-right of the Option Board.

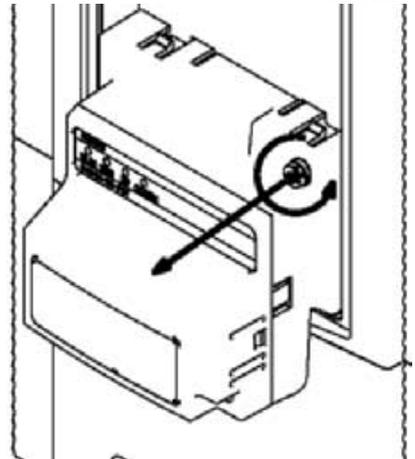

Step 3 **RX** Remove the Terminal cover from the inverter.

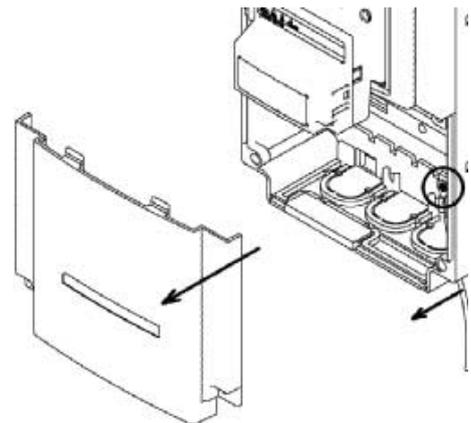

Step 4

RX Unscrew the Option Board grounding cable, mounted with an Inverter grounding bold.

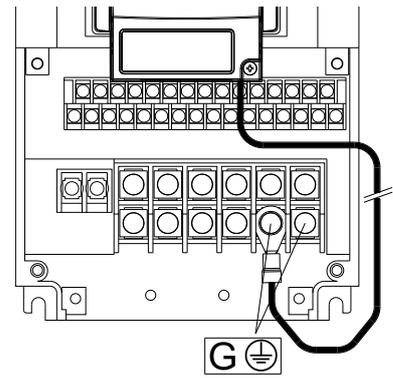

Step 5

RX Gently pull the Option Board straight out while pushing down on the indicated spots to release the snap-fits.. Be careful not to stress the flex cable

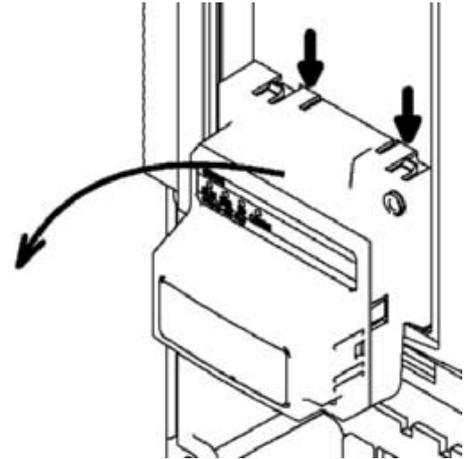

Step 6

RX Remove the flex cable from the inverter by pulling on the indicated locations.

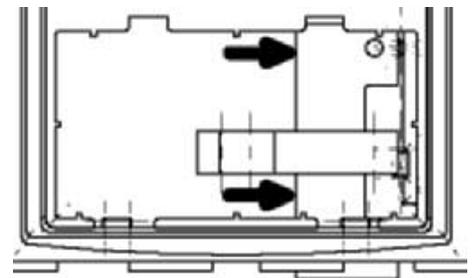

Step 7

Purpose: mount the new Inverter Connector (no.1) of the Option Board onto the interface connector (no.5) of the RX Inverter.

How to do:

First align the small hole of the Inverter connector (no.2) with the guide-post (no.4) in the Inverter.

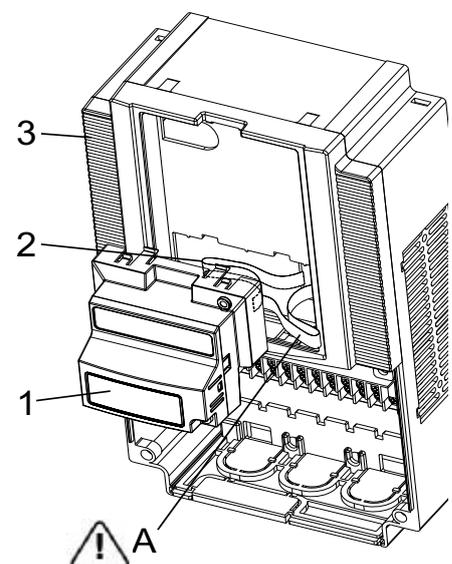

Then align the larger hole on the Inverter connector (no.3) with the threaded hole (no.6) in the Inverter. Push the Inverter connector into place.

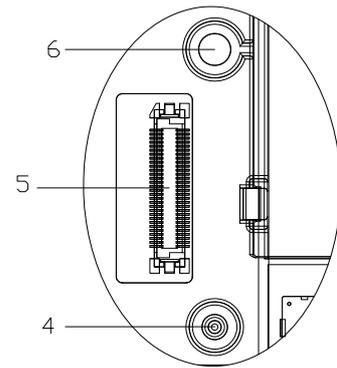

Step 8

RX Move the Option Board Cable (no.2) to the left with your finger, so the Option Board Cable is not pinched between the Option Board and the Inverter Front Cover.

Note Prevent a pinched Option Board Cable, as shown in position A.

Note Do not pull on the Option Board Cable.

Note Do not let the Option Board hang on the Option Board Cable.

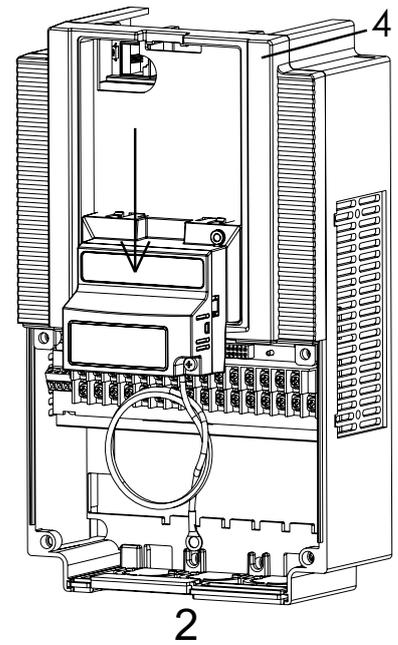
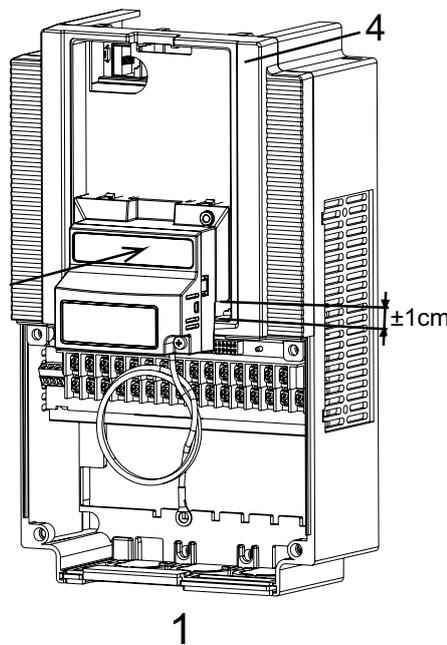

Insert the Option Board approximately 1 cm above the down-position into the Front cover of the Inverter. See figure 1 above.

Slide the Option Board down. See figure 2 above.

The snap-fits of the Option Board (no.5) will be locked by the snap-fits in the Front cover (no.4).

Option Board bottom side

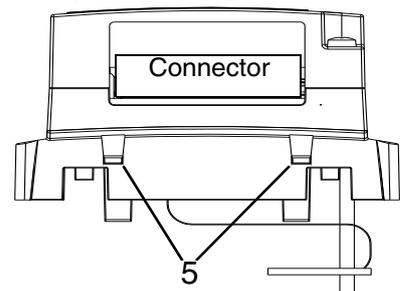

Step 9

- RX** Press down carefully the two locking pins (no. 1) of the Option Board.
- Press carefully the top of the Option Board in the Inverter.
- Check the replacement Option Board is being locked by the locking pins (no.1).

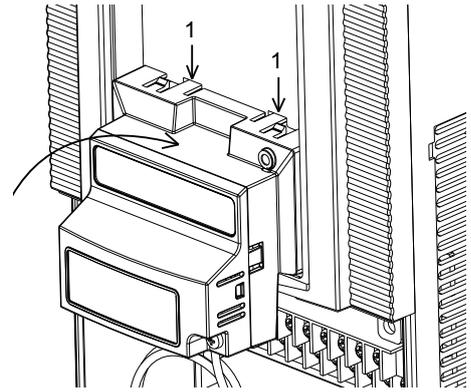

Step 10

- RX** Insert the screw (no. 1) into the upper right hole in the Option Board (no.2).
- Tighten the screw into place (do not over tighten).

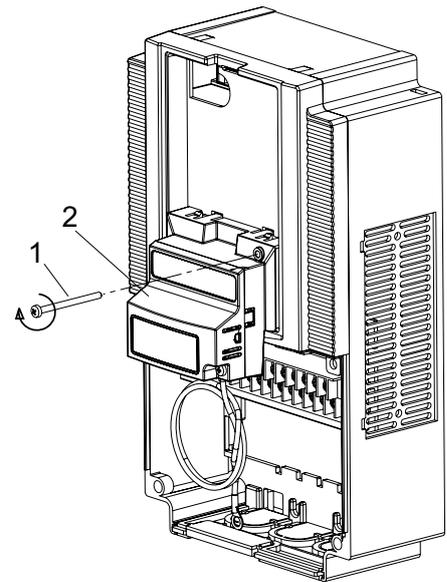

- RX** Fix the Option Board grounding cable to the chassis ground of the RX-Inverter under an already fixed chassis grounding bold.
- See the bold with the grounding figure.

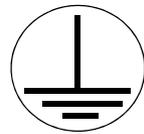

The position of the chassis ground vary from inverter type. Illustrations are only provided for one Inverter size. The instructions however are generic and may be followed for all Inverter sizes.

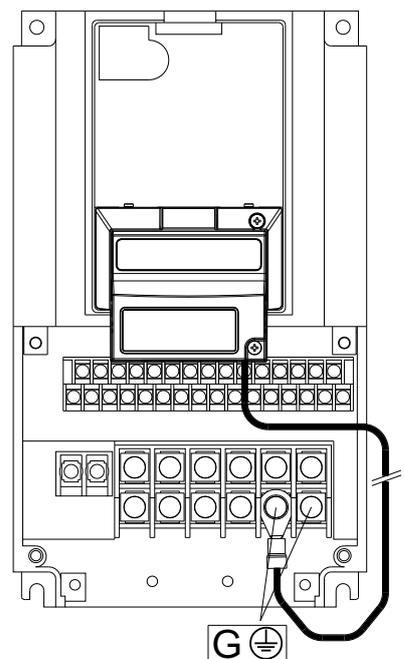

Step 11

- RX** Unscrew the mounting screws of the Terminal cover nearly completely from the plastic rings (no.1).
- Remount the Terminal cover under the Option Board onto the Inverter (no.2).
- Tighten the two screws (no.1).

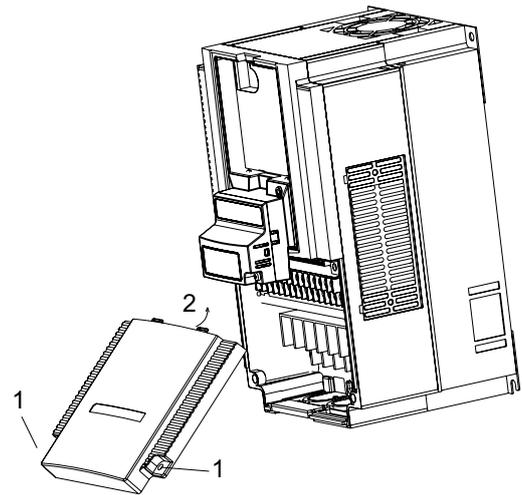

Step 12

- RX** Push the blind cover (no.1) into place.

Note Refer to section 2 in the RX User's Manual (Cat. No. I560) for operations related to assembly and disassembly of the RX Inverter.

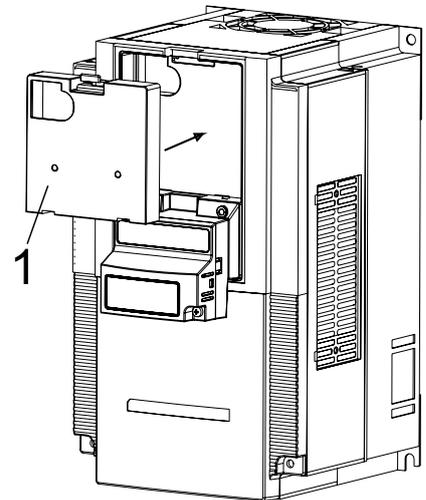

5-4 Warranty

OMRON's exclusive warranty is that the products are free from defects in materials and workmanship for a period of one year (or other period if specified) from date of sale by OMRON.

OMRON MAKES NO WARRANTY OR REPRESENTATION, EXPRESS OR IMPLIED, REGARDING NONINFRINGEMENT, MERCHANTABILITY, OR FITNESS FOR PARTICULAR PURPOSE OF THE PRODUCTS. ANY BUYER OR USER ACKNOWLEDGES THAT THE BUYER OR USER ALONE HAS DETERMINED THAT THE PRODUCTS WILL SUITABLY MEET THE REQUIREMENTS OF THEIR INTENDED USE. OMRON DISCLAIMS ALL OTHER WARRANTIES, EXPRESS OR IMPLIED.

APPENDIX A

Glossary

Device Profile	A device profile defines a common interface and behavior for a range of devices that can be grouped under a particular class.
DP-V1	DP-V1 implements PROFIBUS Acyclic data exchange, cyclic data exchange and alarm handling at the application layer.
DP-V1 Class 2	DP-V1 Class 2 (also known as MSAC2) messaging supports communication relationships between the PROFIBUS DP slave and multiple PROFIBUS DP masters.
EMC	EMC (ElectroMagnetic Compatibility) defines the extent to which a piece of hardware will tolerate electrical interference from other equipment, and will interfere with other equipment.
EMI	Electromagnetic Interference - In motor/drive systems, the switching of high currents and voltages creates the possibility of generating radiated electrical noise that may interfere with the operation of nearby sensitive electrical instruments or devices. Certain aspects of an installation, such as long motor lead wire lengths or an ungrounded chassis, tend to increase the chance of EMI.
FA Systems	Factory Automation Systems implement control systems in combination with other applications of information technology to control industrial machinery and processes. FA Systems are used to reduce the need for human intervention in factory environments.
Fieldbus	Fieldbus is the name of a family of industrial computer network protocols used for real-time distributed control, now standardized as IEC 61158
Free-run Stop	A method of stopping a motor, caused when the Inverter simply turns OFF its motor output connections. This may allow the motor and load to coast to a stop, or a mechanical brake may intervene and shorten the deceleration time.
Frequency Setting	While frequency has a broad meaning in electronics, it refers to motor speed for motor and drive systems. The output frequency of an Inverter is variable and proportional to the attained motor speed.
Intelligent Terminal	A configurable input or output logic function on the Omron Inverters. Each terminal may be assigned one of several functions.
Inverter	A device that electronically changes DC to AC current through an alternating process of switching the input to the output, inverted and non-inverted. It contains three Inverter circuits to generate 3-phase output to the motor.
Jogging Operation	Usually done manually, a jog command from an operator's panel requests the motor/drive system to run indefinitely at low speed in a particular direction. This continues until the machine operator ends the jog operation.
PLC	A PLC (Programmable Logic Controller) is a digital computer used for the automation of electromechanical processes.
Process Area	The Process Area is a memory area in the controller that allows you to control and monitor the Unit. The Fieldbus is used to continually refresh the Process Area to and from decentralized peripherals. A Unit's status- and response to a change in the Process Area therefore isn't instantaneous (The latencies and jitter associated with the communication path limit the responsiveness of the Unit).

PROFIBUS	PROFIBUS (PROcess FieldBUS) is a standard for Fieldbus communication in automation technology
PROFIBUS DP	PROFIBUS DP (PROFIBUS for Decentralised Peripherals) is an implementation of PROFIBUS optimized for distributed I/O applications. PROFIBUS DP devices can co-exist with non-DP PROFIBUS devices on the same bus.
PROFIBUS FMS	PROFIBUS FMS (PROFIBUS Fieldbus Message Specification) is an implementation of the PROFIBUS tailored for demanding communication tasks. PROFIBUS FMS devices can co-exist with non-FMS PROFIBUS devices on the same bus.
PROFIdrive	PROFIdrive implements a common PROFIBUS DP device profile for motion control applications such as drives and Inverters.
Programmable Products	Some products allow customisation of their behavior by allowing the execution of a sequence of user instructions.
Termination	Electrical termination of a signal involves providing a terminator at the end of a wire or cable. Termination prevents an RF signal from causing interference by being reflected back at the end of the cable.
Torque	The rotational force exerted by a motor shaft. The units of measurement consist of the distance (radius from shaft centre axis) and force applied at that distance. Units are usually given as Newton-meters, pound-feet or ounce-inches.
Trip Event	An undesired event that causes the Inverter to stop operation is called a "trip" event (as in tripping a circuit breaker). The Inverter keeps a history log of trip events. They also require an action to clear.
Unit	Within the context of this document, Unit refers to the MX2 or RX Option Board.
Variable Speed Drive	A Variable Speed Drive is a piece of equipment used to control the speed of machinery.
PROFIdrive Device Profile Acronyms HIW	The monitored output frequency is called HIW in the PROFIdrive device profile.
HSW	The commanded frequency reference is called HSW in the PROFIdrive device profile.
PKE	The combination of the task ID and parameter number in the PKW messaging area is called PKE in the PROFIdrive device profile.
PKW	The parameter processing messaging area is called PKW in the PROFIdrive device profile.
PNU	The parameter number is called PNU in the PROFIdrive device profile.
PWE	The parameter value in the PKW messaging area is called PWE in the PROFIdrive device profile.
PZD	The process data (cyclically transferred) is called PZD in the PROFIdrive device profile.
STW	The control word is called STW in the PROFIdrive device profile.
ZSW	The status word is called ZSW in the PROFIdrive device profile.

APPENDIX B

Parameter Process Data Object Modules

The Parameter Process Data Object (PPO) modules implement the cyclic data exchange mapping for the PROFIdrive device profile. Five modules are supported (PPO1 - PPO5) allowing you to select the number of exchanged registers and PKW messaging support. All modules provide two default output words: STW (Control word) and HSW (Frequency Reference), provide control over the Inverter. All modules additionally provide two default input words: ZSW (Status Word) and HIW (Output Frequency) provide feedback on the Inverter status. STW and ZSW are explained in more detail in *appendix B-2*. HSW and HIW are explained in *appendix B-3*. The exchanged Modbus registers are configured by setting Inverter registers P160 - P179 to the appropriate Inverter Modbus addresses. If P160, P161, P170 or P171 are set to 0, STW, HSW, ZSW and HIW are used.

Note Set P182 = 0 for the Option Board to support the PPO modules

Note The Inverter places some restrictions on the Modbus register selection. For a Modbus Register to be mapped for output data exchange, it must be a run-mode edit register that provides write-access. Double-word Modbus registers must be mapped in sequence: high-word following low-word. It is not allowed to map the same register more than once in the output area.

MX2 **Tip** Refer to section B-4-2 of the MX2 Inverter user's manual for a list of the Inverter registers that provide write access.

RX **Tip** Refer to section 5 of the RX2 Inverter user's manual for a list of the Inverter registers that provide write access.

MX2 **Tip** Refer to section 3-2-3 of the MX2 Inverter user's manual for an explanation on run-mode edit registers. Also note that the run-mode edit requirement can be disabled with b031.

RX **Tip** Refer to section 5 of the RX Inverter user's manual for an explanation on run-mode edit registers. Also note that the run-mode edit requirement can be disabled with b031.

B-1 I/O Mapping

Table B-1 PPO format I/O Mapping

Word Offset*1					Content*2			
PPO1	PPO2	PPO3	PPO4	PPO5	Output Area		Input Area	
+0	+0			+0	PKE	Task ID and Parameter number	PKE	Task ID and Parameter number
+1	+1			+1	IND	PNU index / Parameter group in high byte	IND	PNU index / Parameter group in high byte
+2	+2			+2	PWE	High word of value	PWE	High word of value
+3	+3			+3		Low word of value		Low word of value or Error number
+4	+4	+0	+0	+4	PZD1	Modbus register set by P160 or STW if P160 = 0	PZD1	Modbus register set by P170 or ZSW if P170 = 0
+5	+5	+1	+1	+5	PZD2	Modbus register set by P161 or HSW if P161 = 0	PZD2	Modbus register set by P171 or HIW if P171 = 0
	+6		+2	+6	PZD3	Modbus register set by P162 or ignored if P162 = 0	PZD3	Modbus register set by P172 or always 0 if P172 = 0
	+7		+3	+7	PZD4	Modbus register set by P163 or ignored if P163 = 0	PZD4	Modbus register set by P173 or always 0 if P173 = 0
	+8		+4	+8	PZD5	Modbus register set by P164 or ignored if P164 = 0	PZD5	Modbus register set by P174 or always 0 if P174 = 0
	+9		+5	+9	PZD6	Modbus register set by P165 or ignored if P165 = 0	PZD6	Modbus register set by P175 or always 0 if P175 = 0
				+10	PZD7	Modbus register set by P166 or ignored if P166 = 0	PZD7	Modbus register set by P176 or always 0 if P176 = 0
				+11	PZD8	Modbus register set by P167 or ignored if P167 = 0	PZD8	Modbus register set by P177 or always 0 if P177 = 0
				+12	PZD9	Modbus register set by P168 or ignored if P168 = 0	PZD9	Modbus register set by P178 or always 0 if P178 = 0
				+13	PZD10	Modbus register set by P169 or ignored if P169 = 0	PZD10	Modbus register set by P179 or always 0 if P179 = 0

Note 1 If no Word Offset is specified for a Register, the Register does not exist in the Input and Output Areas for the Module Type:

MX2 The Modbus addresses for the MX2 Inverter are listed in section B-4-2 of the MX2 user's manual.

RX The Modbus addresses for the RX Inverter are listed in section 5 of the RX user's manual.

P160-P169 can also be accessed as PNU915.1 - PNU915.10

P170-P179 can also be accessed as PNU916.1 - PNU916.10

B-2 Control and Status Words - STW/ZSW

Note The PZD1 output and input registers will control STW and present ZSW only if P160 = 0 and P170 = 0

Table B-2 PPO format STW/ZSW mapping

Bit	STW (Control Output Word)		ZSW (Status Input Word)	
	Name	Description	Name	Description
0	(Unused)	-	(Reserved)	Always 1
1	(Unused)	-	AC Mains	0: AC Mains off 1: AC Mains on
2	(Unused)	-	Ready for Operation	0: Inverter Not Ready 1: Inverter Operational
3	Enable to Run	0: Free Run Stop (Coast to a stop) 1: Controlled Acceleration/Deceleration	Fault	0: No Fault 1: Has Fault
4	Run Operation	0: Stop 1: Run	(Reserved)	Always 1
5	(Unused)	-	(Reserved)	Always 1
6	(Unused)	-	(Reserved)	Always 0
7	Fault Reset	0→1: Reset Fault	Alarm	0: No Alarm 1: Has Alarm
8	Jog Run Forward	0: Normal Operation 1: Jog Run Forward ^{*1}	Frequency Arrival	0: Reference Freq. Not Reached 1: Reference Frequency Reached
9	Jog Run Reverse	0: Normal Operation 1: Jog Run Reverse ^{*1}	Control Status	0: Other in Control ^{*2} 1: PROFIBUS in Control ^{*3}
10	Control Override	0: Normal Operation ^{*2} 1: PROFIBUS Takes Control ^{*3}	(Reserved)	Always 0
11	(Unused)	-	(Reserved)	Always 0
12	(Unused)	-	(Reserved)	Always 0
13	(Unused)	-	(Reserved)	Always 0
14	(Unused)	-	(Reserved)	Always 0
15	(Unused)	-	(Reserved)	Always 0

Note 1 When jogging, the output frequency is controlled by A038

Note 2 When the Control Override is not set, the Control- and Frequency Sources are determined by A001/A002 or A201/A202

Note 3 When the Control Override is set, PROFIBUS takes over as both Control- and Frequency Source irrespective of A001/A201/A002/A202

B-3 Frequency Reference and Output Frequency - HSW/HIW

The HSW output register controls both the Option Board Frequency Reference and Run Direction. The Run Direction is determined by HSW's sign and the Frequency Reference by HSW's absolute size. Normally HSW has a scaling of 0.01 Hz. If the Inverter is operated in HF mode, the scaling is 0.1 Hz.

Note The PZD2 output register will control HSW only if P161 = 0

The HIW input register represents both the Inverter Run Direction and Output Frequency. The Run Direction is represented by HIW's sign and the Output Frequency by HIW's absolute size. Normally HIW has a scaling of 0.01 Hz. If the Inverter is operated in HF mode, the scaling is 0.1 Hz.

Note The PZD2 input register will present HIW only if P171 = 0

B-4 Parameter Processing Message Area - PKW

The PKW Message Area provides an interface to read and change Inverter or Option Board parameters using the I/O Data Exchange area. Several tasks support reading and changing different parameter types and sizes. A failed task is accompanied by error code detail to simplify diagnosis.

Table B-3 PPO format PKW mapping

Word Offset	Contents	Bit Definitions															
		15	14	13	12	11	10	9	8	7	6	5	4	3	2	1	0
+0	PKE	AK				SPM	PNU										
+1	IND	IND _{PNU} OR							(Unused)								
		IND _{group}															
+2	PWE	High word of value															
+3		Low word of value or Error number															

AK Task ID (Output Area):

- | | |
|---------------------------------|--|
| 0: Clear the input message area | 6: Read element value in array |
| 1: Read parameter value | 7: Change WORD element value in array |
| 2: Change WORD parameter value | 8: Change DWORD element value in array |
| 3: Change DWORD parameter value | 9: Read array size |

Task Response (Input Area):

- | | |
|-----------------------------------|---------------------------------|
| 0: No response | 5: Task success (DWORD element) |
| 1: Task success (WORD parameter) | 6: Task success (Array size) |
| 2: Task success (DWORD parameter) | 7: Task failed (Parameter) |
| 4: Task success (WORD element) | 8: Task failed (Element) |

SPM Unused (Always 0)

PNU Parameter number:

- | | |
|---|--|
| 0: Reserved | 1..889: Inverter parameter (Use IND for parameter group) |
| 890..999: Option Board parameter [Appendix F] | >999: Unsupported |

IND_{PNU} Index in Option Board parameter array (Only evaluated if Task ID is 6, 7 or 8):

IND_{group} Inverter parameter group (Only evaluated if Task ID is 6, 7 or 8):

- | | | | |
|-------------------|-------------------|-------------------|--------------------|
| 1: Parm group 'A' | 3: Parm group 'C' | 6: Parm group 'F' | 16: Parm group 'P' |
| 2: Parm group 'b' | 4: Parm group 'd' | 8: Parm group 'H' | 21: Parm group 'U' |

PWE Parameter value (If Task Response is 1, 2, 4, 5 or 6)
 Error code (If Task Response is 7 or 8): Refer to Appendix G

APPENDIX C Conventional Modules

Conventional modules are provided for backward-compatibility with previous OMRON Inverter products. Three modules are supported: Basic Data, Extended Data 1 and Extended Data 2.

Note Set P182 = 1 for the Option Board to support the Conventional modules

C-1 Basic Data I/O Mapping

Table C-1 Basic data format I/O mapping

Word Offset	Input Area	Output Area
+0	Operation Command ^{*1} (Section C-4)	Inverter Status ^{*1} (Section C-4)
+1	Frequency Reference	Output Frequency
+2	Torque Reference [1 %]	Output Torque [1 %]

^{*1}. Refer to section C-4 Operation Command and Inverter Status Registers on page 80 for the Operation Command and Inverter Status register definitions

MX2 The Torque Reference only becomes effective if: P033 = 6, A044 = 3 and ATR is assigned to a digital input and turned on. Refer to MX2 User Manual section 3-9-4.

RX The Torque Reference only becomes effective if: P033 = 7. Refer to RX User Manual section 4-3 Torque Control.

C-2 Extended Data 1 I/O Mapping

Table C-2 Ext1 data format I/O mapping

Word Offset	Output Area		Input Area	
+0	Operation Command ^{*1} (Section C-4)		Inverter Status ^{*1} (Section C-4)	
+1	Frequency Reference		Speed (Scaled Frequency)	
+2	Torque Reference [1 %]		Output Torque [1 %]	
+3	Torque Compensation [1 %]		Encoder Speed	
+4	(Reserved)		Frequency Reference	
+5	Analog Output Channel 1		Output Frequency	
+6	(Reserved)		Output Current [0.1 A]	
+7	Digital Outputs		Analog Input Channel 1	
+8	Modbus Message Area (Section C-5)	Instruction	Modbus Message Area (Section C-5)	Result
+9		Data		Data
+10				
+11				
+12				
+13		(Unused)		(Unused)
+14		Control		Status
+15				

^{*1}. Refer to section C-4 Operation Command and Inverter Status Registers on page 80 for the Operation Command and Inverter Status register definitions

MX2 **Note** The Torque Reference only becomes effective if: P033 = 6, A044 = 3 and ATR is assigned to a digital input and turned on. Refer to MX2 User Manual section 3-9-4.

- Note** The Torque Compensation only becomes effective if: P036 = 5, A044 = 3 and ATR is assigned to a digital input and turned on. Refer to MX2 User Manual section 3-9-4.
- Note** The Analog Output Channel 1 only becomes effective if: C028 = 16. Refer to MX2 User Manual section 3-7.
- Note** A Digital Output only becomes effective if the associated register (C021, C022 or C026) is set to 63. Refer to MX2 User Manual section 3-7.
- RX** **Note** The Torque Reference only becomes effective if: P033 = 7. Refer to RX User Manual section 4-3 Torque Control for details.
- Note** The Torque Compensation only becomes effective if: P036 = 5. Refer to RX User manual 4-3 Torque Bias.
- Note** The Analog Output Channel 1 only becomes effective if: C028 = 20. Refer to RX User Manual section 4-2 Analogue Output AM/AMI Terminals.
- Note** A Digital Output only becomes effective if the associated register (C021- C026) is set to 63. Refer to RX User Manual section 4-2 Multi-function Output Terminal Selection.

C-3 Extended Data 2 I/O Mapping

Table C-3 Ext2 data format I/O mapping

Word Offset	Output Area		Input Area	
+0	Operation Command* ¹ (Section C-4)		Inverter Status* ¹ (Section C-4)	
+1	Frequency Reference		Output Frequency	
+2	Modbus Message Area (Section C-5)	Instruction	Modbus Message Area (Section C-5)	Result
+3		Data		Data
+4		Control		Status
+5				

*1. Refer to section C-4 Operation Command and Inverter Status Registers on page 80 for the Operation Command and Inverter Status register definitions

C-4 Operation Command and Inverter Status Registers

Table C-4 Conventional control status regs

Bit	Operation Command		Inverter Status	
	Name	Description	Name	Description
0	Forward Run/Stop (FW)	1: Run forward 0: Stop run forward	Operation Status	1: Inverter is running 0: Inverter is stopped
1	Reverse Run/Stop (RV)	1: Run reverse 0: Stop run reverse	0 Hz Detection Signal (ZS)	1: ON 0: OFF
2	Intelligent Input Terminal override [3]	1: ON 0: OFF	Rotation Direction	1: Reverse rotation 0: Forward rotation
3	Intelligent Input Terminal override [4]	1: ON 0: OFF	Trip Reset Status	1: Trip reset (RS) is active 0: Trip reset (RS) not active
4	Intelligent Input Terminal override [5]	1: ON 0: OFF	Set Frequency Reached (FA3)	1: ON 0: OFF
5	Intelligent Input Terminal override [6]	1: ON 0: OFF	Inverter Ready	1: ON 0: OFF
6	Intelligent Input Terminal override [7]	1: ON 0: OFF	Alarm Signal (AL)	1: ON 0: OFF

Table C-4 Conventional control status regs (continued)

Bit	Operation Command		Inverter Status	
	Name	Description	Name	Description
7	RX Intelligent Input Terminal override [8]	1: ON 0: OFF	Trip Status	1: Inverter is tripped 0: Inverter not tripped
8	External Trip (EXT)	0 to 1: Trip inverter	(Reserved)	Always 0
9	Trip Reset (RS)	1: ON 0: OFF	(Reserved)	Always 0
10	(Reserved)	-	PROFIBUS Control Status	1: PROFIBUS is control source 0: PROFIBUS not control source
11	(Reserved)	-	Alarm Relay Output Terminal Status	1: ON 0: OFF
12	(Reserved)	-	Intelligent Output Terminal [11]	1: ON 0: OFF
13	(Reserved)	-	Intelligent Output Terminal [12]	1: ON 0: OFF
14	Clear Error Log	0 to 1: Clear error log	2nd Motor Selected (SETM)	1: 2nd motor selected 0: 1st motor selected
15	Free-run Stop (FRS)	1: Coast to a halt 0: Normal operation	(Reserved)	Always 0

C-5 Extended Data 1 Digital Output Register

C-6 1 Digital Output Register

Table C-5 Ext1 digital output reg for MX2

Bit	Digital Outputs	
	Name	Description
0	Output Terminal 11	1: ON 0: OFF
1	Output Terminal 12	1: ON 0: OFF
2	Alarm Relay Output Terminal	1: ON 0: OFF
3	(Reserved)	-
4	(Reserved)	-
5	(Reserved)	-

Table C-6 Ext1 digital output reg for RX

Bit	Digital Outputs	
	Name	Description
0	Output Terminal 11	0: OFF 1: ON
1	Output Terminal 12	0: OFF 1: ON
2	Output Terminal 13	0: OFF 1: ON
3	Output Terminal 14	0: OFF 1: ON

Table C-6 Ext1 digital output reg for RX

RX	Bit	Digital Outputs	
		Name	Description
	4	Output Terminal 15	0: OFF 1: ON
	5	Alarm Relay Output Terminal	0: OFF 1: ON

C-7 Modbus Message Area

Table C-7 Conventional modbus mailbox

Byte Offset		Output Area								Input Area									
Ext. Data 1	Ext. Data 2		Bit Definitions									Bit Definitions							
			7	6	5	4	3	2	1	0		7	6	5	4	3	2	1	0
+16	+4	Instruction	FUNC								Result	FUNC							
+17	+5		REG									REG							
+18	+6		SIZE									SIZE							
+19	+7	Data	WORD1								Data	WORD1							
+20	+8		WORD2									WORD2							
+21	+9		WORD3									WORD3							
+22	-		WORD4									WORD4							
+23	-																		
+24	-	Ctrl	(Reserved)								Stat	(Reserved)							
+25	-																		
+26	-																		
+27	-																		
+30	+10																		
+31	+11		HS	(Unused)						CL		HS	STATUS	COUNTER			-		

FUNC Command function code (Output Area):

03h: Read

10h: Write

Response function code (Input Area):

03h: Read success

10h: Write success

83h: Read error

90h: Write error

00h: Waiting for response

REG Modbus register address start

SIZE Size of data (Number or words read / write)

2: 1 word

6: 3 words (Ext. Data 1 only)

4: 2 words (Ext. Data 1 only)

8: 4 words (Ext. Data 1 only)

HS Handshake bit (Output Area):

Toggle 0→1 or 1→0 to trigger execution of instruction

Handshake bit (Input Area):

Toggles 0→1 or 1→0 every time an instruction has been triggered

CLR Clear status

0: Normal operation

1: Clear HS, STATUS and COUNTER to 0

STATUS Instruction status

00b: Idle

10b: Waiting for Inverter response

01b: Instruction sent to Inverter

11b: Response received

COUNTER Status counter

4 bit counter that increments once every 64 ms

APPENDIX D

Flexible Module

The Flexible Format implements I/O data exchange that supports direct mapping of Inverter Modbus registers in the I/O area. This offers fieldbus- and profile-independent control of the Inverter. The exchanged registers are configured by setting Inverter registers P160 - P179 to the appropriate Inverter Modbus addresses.

Note Set P182 = 2 for the Option Board to support the Flexible module

Note The Inverter places some restrictions on the Modbus register selection. For a Modbus Register to be mapped for output data exchange, it must be a run-mode edit register that provides write-access. Double-word Modbus registers must be mapped in sequence: low-word following high-word. It is not allowed to map the same register more than once in the output area.

MX2 Refer to Section B-4-2 of the MX2 Inverter user's manual for a list of the Inverter registers that provide write access.

RX Refer to Section "4-4 Register Number List" of the RX Inverter user's manual for a list of the Inverter registers that provide write access.

MX2 Refer to Section 3-2-3 of the MX2 Inverter user's manual for an explanation on run-mode edit registers. Also note that the run-mode edit requirement can be disabled with b031.

RX Refer to Appendix 1 of the RX Inverter user's manual for an explanation on run-mode edit registers. Also note that the run-mode edit requirement can be disabled with b031.

Tip When using Flexible Format, the Inverter is controlled via Modbus registers. I.e. set A001/A002 = 3 and A201/A202 = 3 to make use of the Modbus control registers for typical Flexible Module use.

Flexible I/O Mapping

Table D-1 Flexible format I/O mapping

Word Offset	Content	
	Output Area	Input Area
+0	Modbus register set by P160 Ignored if P160 = 0	Modbus register set by P170 Ignored if P170 = 0
+1	Modbus register set by P161 Ignored if P161 = 0	Modbus register set by P171 Ignored if P171 = 0
+2	Modbus register set by P162 Ignored if P162 = 0	Modbus register set by P172 Ignored if P172 = 0
+3	Modbus register set by P163 Ignored if P163 = 0	Modbus register set by P173 Ignored if P173 = 0
+4	Modbus register set by P164 Ignored if P164 = 0	Modbus register set by P174 Ignored if P174 = 0
+5	Modbus register set by P165 Ignored if P165 = 0	Modbus register set by P175 Ignored if P175 = 0
+6	Modbus register set by P166 Ignored if P166 = 0	Modbus register set by P176 Ignored if P176 = 0
+7	Modbus register set by P167 Ignored if P167 = 0	Modbus register set by P177 Ignored if P177 = 0

Table D-1 Flexible format I/O mapping

Word Offset	Content	
	Output Area	Input Area
+8	Modbus register set by P168 Ignored if P168 = 0	Modbus register set by P178 Ignored if P178 = 0
+9	Modbus register set by P169 Ignored if P169 = 0	Modbus register set by P179 Ignored if P179 = 0

MX2 The Modbus addresses for the MX2 Inverter are listed in section B-4-2 of the MX2 user's manual.

RX The Modbus addresses for the RX Inverter are listed in "Section 4-4 Register Number List" of the RX user's manual.

P160 - P169 can also be accessed as PNU915.1 - PNU915.10

P170 - P179 can also be accessed as PNU916.1 - PNU916.10

Note Irrespective of the user configuration, the size of the module is fixed to 10 words in and 10 words out.

Tip Set the following register values:

- P160 = 1F01h: This gives you control over Modbus Coils 0000h through 000Fh using the first output word. These coils implement all the important control functions of the Inverter.
- P161 = 0001h and P162 = 0002h: This gives you control over the frequency reference using output words 2 and 3.
- P170 = 1E01h: This allows you to monitor Modbus Coils 0010h through 001Fh as the first input word. These coils implement the most important status information of the Inverter.
- P171 = 1001h and P172 = 1002h: This allows you to monitor the output frequency using input words 2 and 3.

MX2 The Modbus coil definitions for the MX2 Inverter are listed in section B-4-1 of the MX2 user's manual.

RX The Modbus coil definitions for the RX Inverter are listed in Section B-4-1 of the RX user's manual.

APPENDIX E

PROFIdrive DP-V1 Parameter Channel

The Option Board provides Parameter Access in accordance with the PROFIdrive V4 profile definition (DP-V1 Slot 0, Index 47). PROFIdrive DP-V1 parameter channel allows reading or changing a number of registers using a highly flexible frame format.

Note PROFIdrive DP-V1 parameter channel is only available via a DP-V1 Class 2 (MSAC2) Messaging connection. Please consult the documentation of your PROFIBUS Master with regard to support for- and usage of a DP-V1 Class 2 Messaging connection. (Version 3.0 and newer of the OMRON CJ1W-PRM21 and CS1W-PRM21 supports this. Special instructions can be obtained from an Omron representative.)

Note This appendix purely describes the PROFIdrive DP-V1 parameter channel Message content.

E-1 Read Parameter Request

Table E-1 PROFIdrive V4 Parameter read request

Word Offset	Contents	High byte	Low byte
+0	Request Header*1	REF	RT
+1		DO	N
+2	1 st Parameter Address	PA ₁	CA ₁
+3		PNU ₁	
+4		IND ₁	
...
+(LEN-3)	N th Parameter Address	PA _N	CA _N
+(LEN-2)		PNU _N	
+(LEN-1)		IND _N	

- REF Request reference (Typically incremented by user program)
- RT Request type:
 - 01h: Parameter read instruction
- DO Drive object:
 - 01h: Inverter number (Only one attached to Option Board)
- N The number of parameter addresses to follow
- PAX Parameter attribute:
 - 10h: Read value(s)
- CAX The number of elements:
 - 0: Single value read (Non array)
 - 1..255: Number of elements to read
- PNUx Parameter number:
 - 0..889: Reserved
 - 890-999: Option Board parameters*2
 - 1001..1999: Parameters A001 to A999
 - 2001..2999: Parameters b001 to b999
 - 3001..3999: Parameters C001 to C999
 - 4001..4999: Parameters d001 to d999
 - 6001..6999: Parameters F001 to F999
 - 8001..8999: Parameters H001 to H999
 - 16001..16999: Parameters P001 to P999
 - 21001..21999: Parameters U001 to U999
- INDx Index to start reading from:
 - 0: Single value read (Non array)
 - 1..65535: Specified array index
- LEN Parameter request frame size in words

Note 1 The request header is preceded by the DP and MSAC2 headers. Describing these however is outside the scope of this manual.

Note 2 Please refer to *APPENDIX F Option Board Parameters* on page 91

E-2 Read Parameter Response

Table E-2 PROFIdrive V4 Parameter read response

Word Offset	Contents	High byte	Low byte
+0	Response Header ^{*1}	REF	RT
+1		DO	N
+2	Parameter Value(s) or Error Number matching 1 st Parameter Address requested ²	FMT ₁	CV ₁
+3		DATA ₁	
+ (DL ₁ +2)			
+ (LEN-DL _N -1)	Parameter Value(s) or Error Number matching N th Parameter Address requested	FMT _N	CV _N
+ (LEN-DL _N)		DATA _N	
+ (LEN-1)			

- REF Response reference (echo-back of request REF)
- RT Response type:
 - 01h: Parameter read success
 - 81h: Parameter read fail / partial fail
- DO Drive object
 - 01h: Inverter number (Only one attached to Option Board)
- N The number of parameter value / error blocks to follow
- FMT_x Parameter value data format
 - 42h: Words to follow
 - 44h: Error number to follow (C_x = 1)
 - 43h: Double-words to follow
- CV_x The number of values of type FMT_x to follow
- DATA_x Value(s) or error response data (Refer to Appendix E-5 Parameter Value Formats (page 90))
- DL_x Length of DATA_x in words
- LEN Parameter response frame size in words

Note 1 The request header is preceded by the DP and MSAC2 headers. Describing these however is outside the scope of this manual.

Note 2 If the Read Parameter Request frame contained errors, the Read Parameter Response frame contains a single error data block.

E-3 Change Parameter Request

Table E-3 PROFdrive V4 Parameter change request

Word Offset	Contents	High byte	Low byte
+0	Request Header*1	REF	RT
+1		DO	N
+2	1 st Parameter Address	PA ₁	CA ₁
+3		PNU ₁	
+4		IND ₁	
+ (3N-1)	N th Parameter Address	PA _N	CA _N
+ (3N)		PNU _N	
+ (3N+1)		IND _N	
+ (3N+2)	Parameter Value(s) matching 1 st Parameter Address	FMT ₁	CV ₁
+ (3N+3)		DATA ₁	
+ (3N+DL ₁ +2)			
+ (LEN-DL _N -1)	Parameter Value(s) matching N th Parameter Address	FMT _N	CV _N
+ (LEN-DL _N)		DATA _N	
+ (LEN-1)			

- REF Request reference (Typically incremented by user program)
- RT Request type:
 - 02h: Parameter change instruction
- DO Drive object
 - 01h: Inverter number (Only one attached to Option Board)
- N The number of parameter addresses to follow
- PA_x Parameter attribute:
 - 10h: Change value(s)
- CA_x The number of elements:
 - 0: Single value change (Non array) 1..255: Number of elements to change
- PNU_x Parameter number:
 - 0..889: Reserved 4001..4999: Parameters d001 to d999
 - 890-999: Option Board parameters*2 6001..6999: Parameters F001 to F999
 - 1001..1999: Parameters A001 to A999 8001..8999: Parameters H001 to H999
 - 2001..2999: Parameters b001 to b999 16001..16999: Parameters P001 to P999
 - 3001..3999: Parameters C001 to C999 21001..21999: Parameters U001 to U999
- IND_x Index to start changing at:
 - 0: Single val change (Non array) 1..65535: Specified array index
- FMT_x Data format of parameter value(s) x
 - 41h: Bytes to follow 43h: Double-words to follow
 - 42h: Words to follow
- CV_x The number of values of type FMT_x to follow
- DATA_x Value data for parameter x (Refer to Appendix E-5 Parameter Value Formats (page 90))
- DL_x Length of DATA_x in words
- LEN Parameter change frame size in words

Note 1 The request header is preceded by the DP and MSAC2 headers. Describing these however is outside the scope of this manual.

Note 2 Please refer to APPENDIX F Option Board Parameters on page 91

E-4 Change Parameter Response

Table E-4 PROFIdrive V4 Parameter change response

Word Offset	Contents	High byte	Low byte
+0	Response Header ^{*1}	REF	RT
+1		DO	N
+2	Zero Data / Error Number and Errorneous Index matching 1 st Parameter Address requested ^{*2}	FMT ₁	CV ₁
+3		DATA ₁	
+ (DL ₁ +2)			
+ (LEN-DL _N -1)	Zero Data / Error Number and Errorneous Index matching N th Parameter Address requested	FMT _N	CV _N
+ (LEN-DL _N)		DATA _N	
+ (LEN-1)			

Optional (See Notes)

- REF Response reference (echo-back of request REF)
- RT Response type:
 - 02h: Parameter change success
 - 82h: Parameter change fail / partial fail
- DO Drive object:
 - 01h: Inverter number (Only one attached to Option Board)
- N The number of parameters changed / The number of errors / null values to follow
- FMT_x Data format of parameter value(s) x
 - 42h: Words to follow
 - 44h: Error number to follow (C_x = 1)
 - 43h: Double-words to follow
- CV_x The number of values of type FMT_x to follow
- DATA_x Value or error data for parameter x (Refer to Appendix E-5 Parameter Value Formats (page 90))
- DL_x Length of DATA_x in words
- LEN Parameter response frame size in words

Note 1 The request header is preceded by the DP and MSAC2 headers. Describing these however is outside the scope of this manual.

Note 2 If all changes were applied successfully, the Change Parameter Response frame will contain no data (only the Response Header). If the Change Parameter Request frame contained errors, the Change Parameter Response frame contains a single error data block.

E-5 Parameter Value Formats

Table E-5 PROFIdrive V4 Parameter data format

Byte Offset	FMT _x Value and Pre-condition						
	41h where C _x is even	41h where C _x is odd	42h	43h	44h in a Change Response	44h in a Request Response	40h ^{*1}
+0	Byte 1	Byte 1	Word 1	Double- word 1	Error number ^{*2}	Error number ^{*2}	
+1	Byte 2	Byte 2			Word 2	Erroneous index ^{*3}	
+2	Byte 3	Byte 3	Word C _x -1	Double- word C _x			
+3	Byte 4	Byte 4			Word C _x		
+(DL _x /2 - 4)	Byte C _x -3	Byte C _x -2	Word C _x				
+(DL _x /2 - 3)	Byte C _x -2	Byte C _x -1			0 (padding)		
+(DL _x /2 - 2)	Byte C _x -1	Byte C _x					
+(DL _x /2 - 1)	Byte C _x						

Note 1 Zero data (FMT = 40h) is not followed by any data

Note 2 Please refer to APPENDIX G PROFIdrive Error Numbers on page 93

Note 3 In a Change Parameter Response frame, the response error number is followed by the index at which the failure occurred. All indexes before the erroneous index were written successfully, but all indexes following the erroneous index were skipped. The erroneous index will be 0 if the parameter is not an array.

APPENDIX F

Option Board Parameters

Table F-1 Option Board Parameters

PNU	R/W	Res	Name	IND in PNU	Description	Inverter Param
890	R	-	Commissioning mode status	-	0: Commissioning mode NOT active 1: Commissioning mode active	-
	W	-	Set commissioning mode time	-	The number of seconds for commissioning mode to remain active	-
904	R	-	PPO Write format	-	1: PPO1, 2: PPO2, 3: PPO3, 4: PPO4, 5: PPO5	-
911	R	-	PPO Read format	-	1: PPO1, 2: PPO2, 3: PPO3, 4: PPO4, 5: PPO5	-
918	R	-	PROFIBUS node address	-	The Option Board node address	P180
963	R	-	Baudrate on PROFIBUS	-	0: 9.6kbps, 1: 19.2kbps, 2: 93.75kbps, 3: 187.5kbps, 4: 500kbps, 6: 1.5Mbps, 7: 3Mbps, 8: 6Mbps, 9: 12Mbps, 10: 31.25kbps, 11: 45.45kbps	-
964	R	-	Option Board Identification	-	Array of words: [1]: Manufacturer ID = 328, [2]: Drive unit type = 1, [3]: Firmware version = xxyy (Ver. xx.yy), [4]: Firmware year = YYYY, [5]: Firmware date = DDMM, [6]: Number of drive Objects = 1	-
965	R	-	Profile code	-	0302h	-
967	R/W	-	STW	-	Current value of STW	-
968	R	-	ZSW	-	Current value of ZSW	-
915	R/W	-	Output PZD assignments	1	Modbus address mapped into output PZD1 0 (zero) means STW	P160
				2	Modbus address mapped into output PZD2 0 (zero) means HSW	P161
				3	Modbus address mapped into output PZD3	P162
				4	Modbus address mapped into output PZD4	P163
				5	Modbus address mapped into output PZD5	P164
				6	Modbus address mapped into output PZD6	P165
				7	Modbus address mapped into output PZD7	P166
				8	Modbus address mapped into output PZD8	P167
				9	Modbus address mapped into output PZD9	P168
				10	Modbus address mapped into output PZD10	P169
916	R/W	-	Input PZD assignments	1	Modbus address mapped into input PZD1 0 (zero) means ZSW	P170
				2	Modbus address mapped into input PZD2 0 (zero) means HIW	P171
				3	Modbus address mapped into input PZD3	P172
				4	Modbus address mapped into input PZD4	P173
				5	Modbus address mapped into input PZD5	P174
				6	Modbus address mapped into input PZD6	P175
				7	Modbus address mapped into input PZD7	P176
				8	Modbus address mapped into input PZD8	P177
				9	Modbus address mapped into input PZD9	P178
				10	Modbus address mapped into input PZD10	P179

Table F-1 Option Board Parameters (continued)

PNU	R/W	Res	Name	IND in PNU	Description	Inverter Param
947	R	-	Fault number of failures	1	Failure 1 (Most recent)	d081
				2 .. 8	(Reserved)	-
				9	Failure 2	d082
				10 .. 16	(Reserved)	-
				17	Failure 3	d083
				18 .. 24	(Reserved)	-
				25	Failure 4	d084
				26 .. 32	(Reserved)	-
				33	Failure 5	d085
				34 .. 40	(Reserved)	-
				41	Failure 6 (Oldest)	d086
42 .. 48	(Reserved)	-				
948	R	1 [ms elapsed since power-on]	Fault time of failures	1	Failure 1 (Most recent)	d081
				2 .. 8	(Reserved)	-
				9	Failure 2	d082
				10 .. 16	(Reserved)	-
				17	Failure 3	d083
				18 .. 24	(Reserved)	-
				25	Failure 4	d084
				26 .. 32	(Reserved)	-
				33	Failure 5	d085
				34 .. 40	(Reserved)	-
				41	Failure 6 (Oldest)	d086
42 .. 48	(Reserved)	-				
971	W	-	Store in non-volatile memory	-	1: Store all parameter data in non-volatile memory	-
972	R/W	-	Reset Option Board	-	2: Prepare for reset 2→1: Reset Option Board	-

APPENDIX G

PROFIdrive Error Numbers

Table G-1 PROFIdrive Error Numbers

Error number	Meaning	Likely Causes	
		Erroneous fields	Description
0000h	Bad parameter number	PNU	PNU is unknown
0001h	Parameter value cannot be changed	AK / RT	PNU is not writeable
0002h	Low or high limit exceeded	Value / DATA	Change value is outside the allowable limits
0003h	Faulty array index	IND	IND is out of range for PNU
0004h	Parameter is not an array	AK / IND	PNU was accessed as if it an array, but it is not an array
0005h	Incorrect data type	AK / FMT	Change value data type doesn't match internal data type of the PNU
0009h	No description available	AK / PA	Unsupported AK or PA was used
000Fh	No text array available	PA	Unsupported PA was used
0011h	Not allowed due to operating state	-	<ul style="list-style-type: none"> • Inverter is running • Inverter is tripped • Reset-sequence not correctly followed
0012h	Other error	-	Inverter responded with an unknown error code
0013h	Parameter value cannot be read	AK / RT	PNU is not readable
0015h	Response too long	N, IND	Response is too large to be sent
0017h	Illegal request format	N, PA, FMT	<ul style="list-style-type: none"> • The request frame is too large • N, PA or FMT has unsupported value • Other errors in the frame format
0018h	Inconsistent number of values	CA, CV	CV is not consistent with CA. Rules are: <ul style="list-style-type: none"> • CV = 1 when CA = 0 • CV = CA when CA ≠ 0
0019h	Bad device object	DO	DO ≠ 1
0065h	Partial access of double-word value	FMT	Only the high-word of a double-word was accessed

APPENDIX H

Slave_Diag Message (SAP60)

Table H-1 Slave_Diag Message (SAP60)

Byte Offset	Bit							
	7	6	5	4	3	2	1	0
+0	Station not existent	Station not ready	Configuration fault	Extended Diagnostics	Function not supported	Invalid slave response	Parameter fault	Master lock
+1	Slave deactivated	(Reserved)	Sync mode	Freeze mode	Watchdog on	(always 1)	Static diagnosis	Parameter request
+2	Extended diagnostic overflow	(Always 0)						
+3	Node address of master							
+4	<div style="display: flex; align-items: center; justify-content: center;"> <div style="border: 1px solid black; padding: 2px; margin-right: 5px;">MX2</div> Device Ident-number (Always 0C6A Hex) </div> <div style="display: flex; align-items: center; justify-content: center; margin-top: 5px;"> <div style="border: 1px solid black; padding: 2px; margin-right: 5px;">RX</div> Device Ident-number (Always 0D2F Hex) </div>							
+5								
+6	Extended diagnostic length (Always 6)							
+7	Status report (Always 1)	Status type (Always 1)						
+8	Slot number (Always 0)							
+9	(Always 0)						Status specifier (Always 0)	
+10	Commission mode is active	(Reserved)	Invalid option parameters	Node storage failed	Mapped input reg rejected	Mapped output reg rejected	Inverter comms error	AC power failure

Table index

Table 1	Option Board Specifications	3
Table 2	LED Indicators.	9
Table 3	Ground cable screw selection.	13
Table 4	PROFIBUS connector pinout	19
Table 5	Option Board Dimensions	20
Table 6	Option Board Dimensions on the RX Inverter.	21
Table 7	Configuration of device profile.	23
Table 8	Configuration of Inverter Reset Mode Selection	23
Table 9	Configuration of PROFIBUS parameters	23
Table 10	Configuration of Inverter source selection parameters	24
Table 11	Configuration of Source selection MX2 parameters	24
Table 12	Configuration of input and output content	25
Table 13	Configuration of module support.	27
Table 14	Output Process Area.	29
Table 15	Input Process Area	30
Table 16	Output Process Area with Motor Started.	31
Table 17	Input Process Area with Reference Frequency Reached	31
Table 18	Output Process Area with Motor Set to Run Reverse.	31
Table 19	Input Process Area with Reverse Frequency Reached	31
Table 20	Output Process Area for Controlled Stop	32
Table 21	Input Process Area after Controlled Stop	32
Table 22	Output Process Area with Motor Jogging Forward	32
Table 23	Input Process Area with Motor Jogging Forward	33
Table 24	Output Process Area with Double Word Frequency Reference	34
Table 25	Input Process Area with Double Word Output Frequency	34
Table 26	Output Process Area with Forward Rotation Dword Frequency Reference	34
Table 27	Input Process Area with Forward Rotation Dword Output Frequency	34
Table 28	Output Process Area with Reverse Rotation Dword Frequency Reference	34
Table 29	Input Process Area with Reverse Rotation Dword Output Frequency	34
Table 30	Output Process Area with Modbus Coil Data 0.	35
Table 31	Output Process Area Configured for Torque Control	36
Table 32	Input Process Area Configured for Torque Control.	36
Table 33	Output Process Area Configured with Forward Torque Command.	37
Table 34	Output Process Area Configured with Reverse Torque Command	37
Table 35	Output Process Area when Using EXT to Trip Inverter.	38
Table 36	Input Process Area with Inverter Tripped	39
Table 37	Output Process Area when Clearing Trip	39
Table 38	Input and Output Parameter Processing Message Area-PKW.	39
Table 39	Parameter Processing Tasks	40
Table 40	Parameter Processing Task Responses.	40
Table 41	Parameter Processing Message Area-Reading PNU965	41
Table 42	Parameter Processing Message Area-Reading PNU915.3	41
Table 43	Parameter Processing Message Area-Changing PNU915.3	41
Table 44	Parameter Processing Message Area-Initiating NV Store	42
Table 45	Parameter Processing Message Area-Prepare Reset	42
Table 46	Parameter Processing Message Area-Initiate Reset	42
Table 47	IND Values and Parameter Groups for Parameter Processing.	42
Table 48	Parameter Processing Message Area-Reading P180	43
Table 49	Parameter Processing Message Area-Changing A001	43
Table 50	Parameter Processing Message Area-Reading F002.	43
Table 51	Parameter Processing Message Area-Changing F002.	44
Table 52	DP-V1 Class 2 Write-Parameter Read Instruction PNU965	46
Table 53	DP-V1 Class 2 Read-Result of PNU965 Read Instruction	46
Table 54	DP-V1 Class 2 Write-Array Read Instruction PNU915.1-915.4	46
Table 55	DP-V1 Class 2 Read-Result of PNU915.1-915.4 Read Instruction.	46

Table 56	DP-V1 Class 2 Write-Array Change Instruction PNU915.3-915.4	47
Table 57	DP-V1 Class 2 Read-Result of PNU915.3-915.4 Change Instruction	47
Table 58	DP-V1 Class 2 Write-Parameter Change Instruction PNU971	47
Table 59	DP-V1 Class 2 Read-Result of PNU971 Change Instruction	47
Table 60	DP-V1 Class 2 Write-Multi-parameter Change Instruction PNU972	48
Table 61	DP-V1 Class 2 Write-Parameter Read Instruction P180	49
Table 62	DP-V1 Class 2 Read-Result of P180 Read Instruction	49
Table 63	DP-V1 Class 2 Write-Parameter Change Instruction A001	49
Table 64	DP-V1 Class 2 Read-Result of A001 Change Instruction	49
Table 65	DP-V1 Class 2 Write-Parameter Read Instruction F002	50
Table 66	DP-V1 Class 2 Read-Result of F002 Read Instruction	50
Table 67	DP-V1 Class 2 Write-Parameter Change Instruction F002	50
Table 68	DP-V1 Class 2 Read-Result of F002 Change Instruction	50
Table 69	DP-V1 Class 2 Write-Parameter Read Instruction Bad Parameter	51
Table 70	DP-V1 Class 2 Read-Result of Read Instruction on Bad Parameter	51
Table 71	DP-V1 Class 2 Write-Parameter Change Instruction Bad Parameter	52
Table 72	DP-V1 Class 2 Read-Result of Change Instruction on Bad Parameter	52
Table 73	Flex Mode Output Area with Typical Configuration	53
Table 74	Flex Mode Input Area with Typical Configuration	53
Table 75	Flex Mode Output Area with Motor Running Forward	54
Table 76	Flex Mode Input Area with Motor Running Forward	54
Table 77	Limitations Caused by Inverter Mode and Rating Selection MX2	55
Table 78	Limitations Caused by Inverter Mode and Rating Selection RX	55
Table 79	Option board or inverter errors	58
Table 80	Configuration Errors	59
Table 81	PROFIBUS Errors	60
Table 82	Standard diagnostic information	62
Table 83	Extended diagnostic information	63
Table B-1	PPO format I/O Mapping	76
Table B-2	PPO format STW/ZSW mapping	77
Table B-3	PPO format PKW mapping	78
Table C-1	Basic data format I/O mapping	79
Table C-2	Ext1 data format I/O mapping	79
Table C-3	Ext2 data format I/O mapping	80
Table C-4	Conventional control status regs	80
Table C-5	Ext1 digital output reg for MX2	81
Table C-6	Ext1 digital output reg for RX	81
Table C-7	Conventional modbus mailbox	82
Table D-1	Flexible format I/O mapping	83
Table E-1	PROFIdrive V4 Parameter read request	86
Table E-2	PROFIdrive V4 Parameter read response	87
Table E-3	PROFIdrive V4 Parameter change request	88
Table E-4	PROFIdrive V4 Parameter change response	89
Table E-5	PROFIdrive V4 Parameter data format	90
Table F-1	Option Board Parameters	91
Table G-1	PROFIdrive Error Numbers	93
Table H-1	Slave_Diag Message (SAP60)	95

Revision history

A manual revision code appears as a suffix to the catalog number on the front cover of the manual.

Cat. No. I112E-EN-02

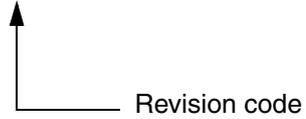

The following table outlines the changes made to the manual during each revision. Page numbers refer to the previous version.

Revision code	Date	Revised content
02	Aug 2011	Added RX Option Board 3G3AX-RX-PRT-E description
01	Jul 2010	Original production

OMRON EUROPE B.V. Wegalaan 67-69, NL-2132 JD, Hoofddorp, The Netherlands.
Tel: +31 (0) 23 568 13 00 Fax: +31 (0) 23 568 13 88 www.industrial.omron.eu

Austria

Tel: +43 (0) 2236 377 800
www.industrial.omron.at

Belgium

Tel: +32 (0) 2 466 24 80
www.industrial.omron.be

Czech Republic

Tel: +420 234 602 602
www.industrial.omron.cz

Denmark

Tel: +45 43 44 00 11
www.industrial.omron.dk

Finland

Tel: +358 (0) 207 464 200
www.industrial.omron.fi

France

Tel: +33 (0) 1 56 63 70 00
www.industrial.omron.fr

Germany

Tel: +49 (0) 2173 6800 0
www.industrial.omron.de

Hungary

Tel: +36 (0) 1 399 30 50
www.industrial.omron.hu

Italy

Tel: +39 02 326 81
www.industrial.omron.it

Netherlands

Tel: +31 (0) 23 568 11 00
www.industrial.omron.nl

Norway

Tel: +47 (0) 22 65 75 00
www.industrial.omron.no

Poland

Tel: +48 (0) 22 645 78 60
www.industrial.omron.com.pl

Portugal

Tel: +351 21 942 94 00
www.industrial.omron.pt

Russia

Tel: +7 495 648 94 50
www.industrial.omron.ru

South Africa

Tel: +27 (0) 11 608 30 41
www.industrial.omron.co.za

Spain

Tel: +34 913 777 900
www.industrial.omron.es

Sweden

Tel: +46 (0) 8 632 35 00
www.industrial.omron.se

Switzerland

Tel: +41 (0) 41 748 13 13
www.industrial.omron.ch

Turkey

Tel: +90 212 467 30 00
www.industrial.omron.com.tr

United Kingdom

Tel: +44 (0) 870 752 08 61
www.industrial.omron.co.uk

Note: Specifications subject to change without notice.
Cat. No. I111E-EN-02

OMRON