



UniOp

Universal Operator Panels

Installation Guide

 **WARNING**

Yaskawa manufactures component parts that can be used in a wide variety of industrial applications. The selection and application of Yaskawa products remains the responsibility of the equipment designer or end user. Yaskawa accepts no responsibility for how its products may be incorporated into the final design.

Under no circumstances should any Yaskawa product be incorporated into any product or design as the exclusive or sole safety control. Without exception, all controls should be designed to dynamically fault detect and fail safely under all circumstances. All products designed to incorporate a component part manufactured by Yaskawa must be supplied to the end user with appropriate warnings and instructions as to the safe use and operation. Any warnings provided by Yaskawa must be passed through to the end user.

Yaskawa offers an express warranty only as to the quality of its products to conform to the catalog specifications. No other warranty, express or implied, is offered. Yaskawa assumes no liability for any personal injury, property damage, losses or claims arising out of the misapplication of its products.

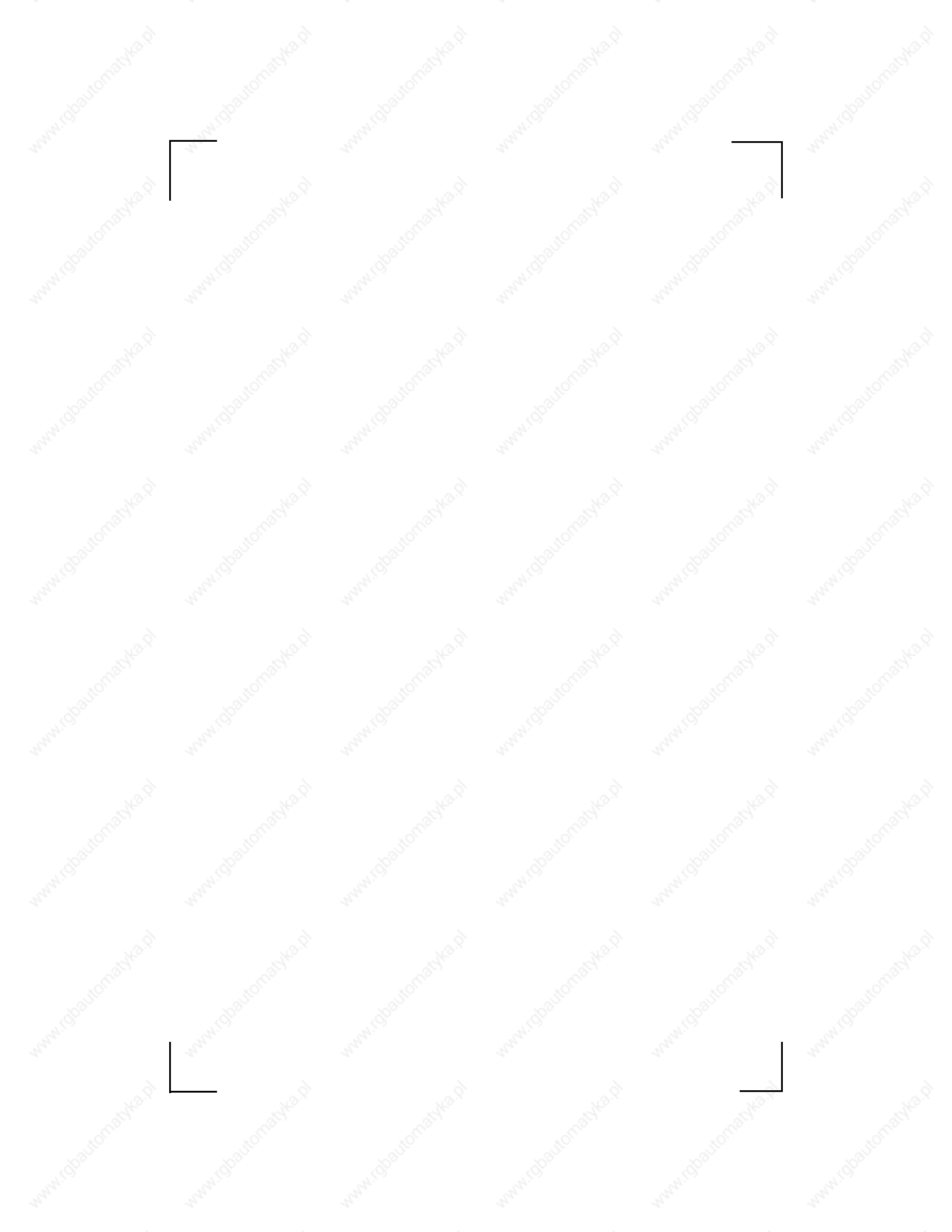

CONTENTS

Introduction	1
Product Identification	1
Technical Specifications	2
Environmental Conditions	2
Electromagnetic Compatibility (EMC)	3
Technical Data	4
Installation	7
Physical Dimensions	7
Connections	11
Power Supply and Grounding	14
PLC Port	16
Cable Accessories	17
MP940 & HMI RS485 Multi-drop Wiring	17
HMI-C940-10	18
HMI-C923-11	19
HMI-CSMC-13	20
HMI-CHMI-16	21
HMI-CMOD-14	22
HMI-C600-12	23
PC/Printer Port	24
AUX Port	25
Models without the PC/Printer Port	25
External Keyboard Port	25
Battery Replacement	26
Removing the Legends	26
Dedicated LEDs	27
Usage and Safety Guidelines	28
Applicable Regulations	28
Installation Environment	28
Applying the Rectangular Gasket	29
Applying the Two Linear Gaskets	30
Cleaning Faceplates	30
Getting Started	31
Command Summary	31
Configuration Mode	32
Operation Mode	32
Command Menu	33
System Menu	33
Data Entry Mode	34
Alarm Mode	34
Event Mode	34
Password Entry Mode	35
Time and Date Set Mode	35
Direct Page Selection Mode	35
Direct Access Mode	36
Troubleshooting	36
Touchscreen Calibration	37
Emergency Calibration	37
Field Firmware Upgrade Guide	37
Options	41
TCM10 Ethernet Communication Model	42
TCM08 Profibus DP Connection Module	46

Universal Operator Panels Installation Guide

TCM03 DeviceNet Connection Module	48
SCM03 PLC Module	50
UIM03 Discrete I/O Modules	52
Installing the UIM03 I/O Module	54
UIM05 Discrete I/O Modules	56
Installing the UIM05 I/O Module	61
MEM-08	63
MEM-16	63

Introduction

This installation guide describes the main features of the UniOP operator panels. The guide refers to the following models:

MD00R-02	Low-cost operator interface with LCD display - 2x20, 2 port, 4 F key
CP11G-04	Operator interface with LCD display - 4x20, 2 port, 12 F key
CP10G-04	Operator interface with LCD display - 4x20, 3 port, 12 F key
eTOP12	Operator interface with touch and monochrome display - 5.6", 3 port
eTOP11	Operator interface with touch and STN color display - 5.6", 3 port, 16 color
eTOP10	Operator interface with touch and TFT color display - 5.6", 3 port, 256 color
eTOP30	Operator interface with touch and TFT color display - 10.4", 3 port, 256 color

The products have been designed for installation in an industrial environment in compliance with the regulations:

Emitted interference	EN 50081-2, 1993
Noise Immunity	EN 50082-2, 1994

In compliance with the above regulations the products are CE marked.

Product Identification

The product may be identified through a plate attached to the rear cover. You will have to know the type of unit you are using for correct usage of the information contained in the guide.

An example of this plate is shown in the figure below:



MD00R-02-0045	Product model name (0045 indicates communication Hardware Rev. level)
03/99	Month/year of production
20234 31623	Serial number
H/W V 33A	Identifies CPU board revision level
S/W V FW 32 4.20	Indicates CPU chip identifier Firmware release identifier

Technical Specifications

Power supply voltage	18 - 30VDC
Power consumption	(1)
Back-up battery ⁽¹⁾	3V Lithium, not rechargeable, life about 1 year, user replaceable, model: Duracell DL2430
OC Protect	All models are equipped with an overcurrent protection device.

Environmental Conditions

Operating temperature	0 ÷ +50°C	IEC 68-2-14
Storage temperature	-20 ÷ +70°C	IEC 68-2-14
Operating and storage humidity	5 ÷ 95 % RH not-condensing	IEC 68-2-3
Vibration	10 ÷ 57Hz, 0,075mm peak 57 ÷ 500Hz, 1g	IEC 68-2-6
Shock	50g, 11ms, 3 pulses per axis	IEC 68-2-27
Protection class	IP65 front panel ⁽²⁾	IEC 529
Keyboard reliability	> 3 million operations	
Touch screen technology	resistive	
Touch screen reliability	> 1 million operations	

Electromagnetic Compatibility (EMC)

Emitted interference	Class A	EN 55011
Immunity to radiated radio frequency electromagnetic field	80MHz ÷ 1GHz, 10V/m 900MHz, 10V/m	ENV 50140 ENV 50204
Immunity to conducted disturbances induced by radio frequency field	0.15 ÷ 80MHz, 10V	ENV 50141
Fast transient	2KV power supply 1KV signal lines	EN 61000-4-4
Electrostatic discharge	8KV in air	EN 61000-4-2
PC/Printer Port ⁽¹⁾	RS-232connector D-sub 15 pin female 300 - 38400 baud	
PLC Port	RS-232, RS-422, RS-485, C.L. 20 mA (active), connector D-15 pin male 300 - 38400 ⁽¹⁾ baud	
AUX Port	connector D-9 pin female (functionality can be configured with an optional communication module)	
User memory	(1)	
Recipe memory ⁽¹⁾	16KB / 32KB RAM with back-up battery	
Hardware clock ⁽¹⁾	Clock/Calendar with back-up battery	
Alarms ⁽¹⁾	256/1024	
Historical event list ⁽¹⁾	last 256/1024 events with back-up battery	
Programming software	Designer version 5.08v01 or Enhanced Designer 6.0	

Note:

- (1) This feature depends on the panel model; see the table below. All the installation instructions listed in the 'Installation Environment' section must be followed in detail.

Technical Data

Model	MD00R-02	CP11G-04
Display	2 x 20 LCD	4 x 20 LCD
Graphics	—	120 x 32
Display dimensions (mm)	—	70 x 21
Diagonal (inches)	—	2.8"
Character height (mm)	6	—
User memory (applications + protocol)	128KB Flash (96+32KB)	128KB Flash (96 + 32)KB
User memory expansion	—	up to 640KB
Function keys	4	12
System keys	7	23
Touch screen	—	—
User LEDs	5	13
System LEDs	4	4
PC/Printer port	—	—
PLC port	Yes	Yes
AUX port	Yes	Yes
External keyboard port	—	—
Programming speed	38400bps	38400bps
Battery	—	—
Recipe memory	—	—
Alarms	256	256
Events list	—	—
Hardware clock	—	—
Downloadable characters	8	256
Screen saver	—	—
Buzzer	—	—
Max power consumption on 24VDC (mA)	250	300
Dimensions W x H x D (mm)	149x109x65	141 x 176 x 76
Max panel thickness (mm)	5	5
Weight (Kg)	0.9	1.1

Technical Data (Cont.)

Model	CP10G-04	eTOP12	eTOP11
Display	4 x 20 LCD	Monochrome LCD	STN color LCD
Graphics	120 x 32	320 x 240	320 x 240
Display dimensions (mm)	70 x 21	121 x 91mm (1/4 VGA)	121 x 91mm (1/4 VGA)
Diagonal (inches)	2.8"	5.6	5.6
Character height (mm)	—	—	—
User memory (applications + protocol)	128KB Flash (96 + 32)KB	8Mb (SSFDC Card)	8Mb (SSFDC Card)
User memory expansion	up to 640KB	—	—
Function keys	12	—	—
System keys	23	—	—
Touch screen	—	Resistive (3 million operations)	Resistive (3 million operations)
User LEDs	13	—	—
System LEDs	4	5	5
PC/Printer port	Yes	Yes	Yes
PLC port	Yes	RS-232, RS-485, RS-422, 20 Ma CL	RS-232, RS-485, RS-422, 20 Ma CL
AUX port	Yes	Yes	Yes
External keyboard port	—	No	No
Programming speed	9600-38400	9600 - 38400 bps	9600 - 38400 bps
Battery	Yes	Yes	Yes
Recipe memory	16KB	32Kb	32Kb
Alarms	1024	1024	1024
Events list	256	1024	1024
Hardware clock	Yes	Yes, battery backed	Yes, battery backed
Downloadable characters	256	256	256
Screen saver	—	Yes	Yes
Buzzer	—	Yes	Yes
Max power consumption 24VDC (mA)	300	600	600
Dimensions W x H x D (mm)	141 x 176 x 76	187 x 147 x 84	187 x 147 x 84
Max panel thickness (mm)	5	5	5
Weight (Kg)	1.1	1.4	1.4

Technical Data (Cont.)

Model	eTOP10	eTOP30
Display	TFT color LCD	TFT color LCD
Graphics	320 x 240 (1/4 VGA)	640 x 480 (Full VGA)
Display dimensions (mm)	121 x 91mm	218 x 159
Diagonal (inches)	5.6	10.4
Character height (mm)	—	—
User memory (applications + protocol)	8Mb (SSFDC Card)	8MB (SSFDC Card)
User memory expansion	—	—
Function keys	—	—
System keys	—	—
Touch screen	Resistive (3 million operations)	Resistive (3 million operations)
User LEDs	—	—
System LEDs	5	5
PC/Printer port	Yes	Yes
PLC port	RS-232, RS-485, RS-422, 20 Ma CL	RS-232, RS-485, RS-422, 20 Ma CL
AUX port	Yes, with options	Yes, with options
External keyboard port	No	No
Programming speed	9600 - 38400 bps	9600 - 38400bps
Battery	Yes	Yes
Recipe memory	32Kb	32KB
Alarms	1024	1024
Events list	1024	1024
Hardware clock	Yes, battery backed	Yes, battery backed
Downloadable characters	256	256
Screen saver	Yes	Yes
Buzzer	Yes	Yes
Max power consumption on 24VDC (mA)	600	700
Dimensions W x H x D (mm)	187 x 147 x 84	287 x 232 x 91
Max panel thickness (mm)	5	5
Weight (Kg)	1.4	2.25

Installation

UniOP panels are designed to be mounted on the front of an enclosure. The bezel height, bezel width, and the cut-out dimensions for each panel type are given on the following pages.

Note: Remove the red BATTERY PROTECTION strip before installation.

Physical Dimensions

All measurements are given in mm, with ± 0.5 tolerance.

MD00R-02 Dimensions

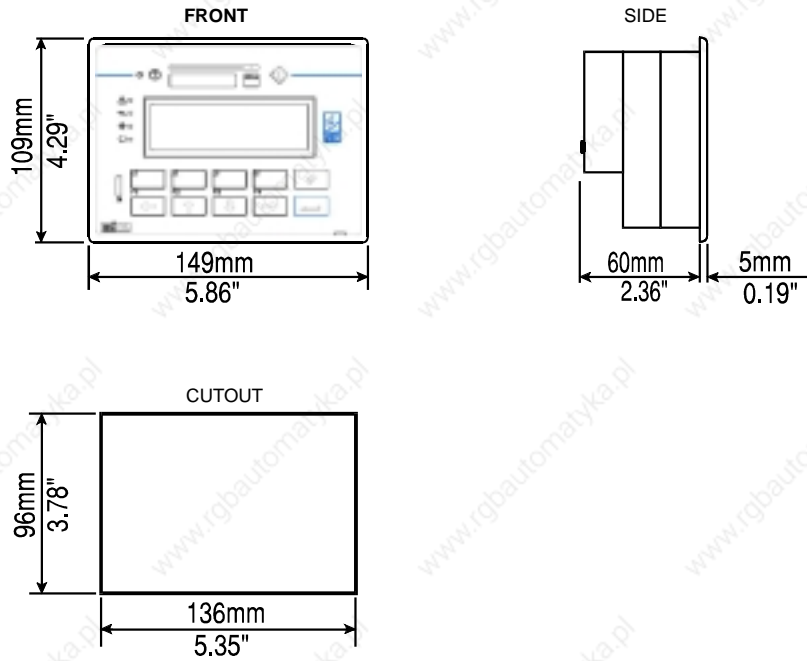

CP11G-04, GP10G-04 Dimensions

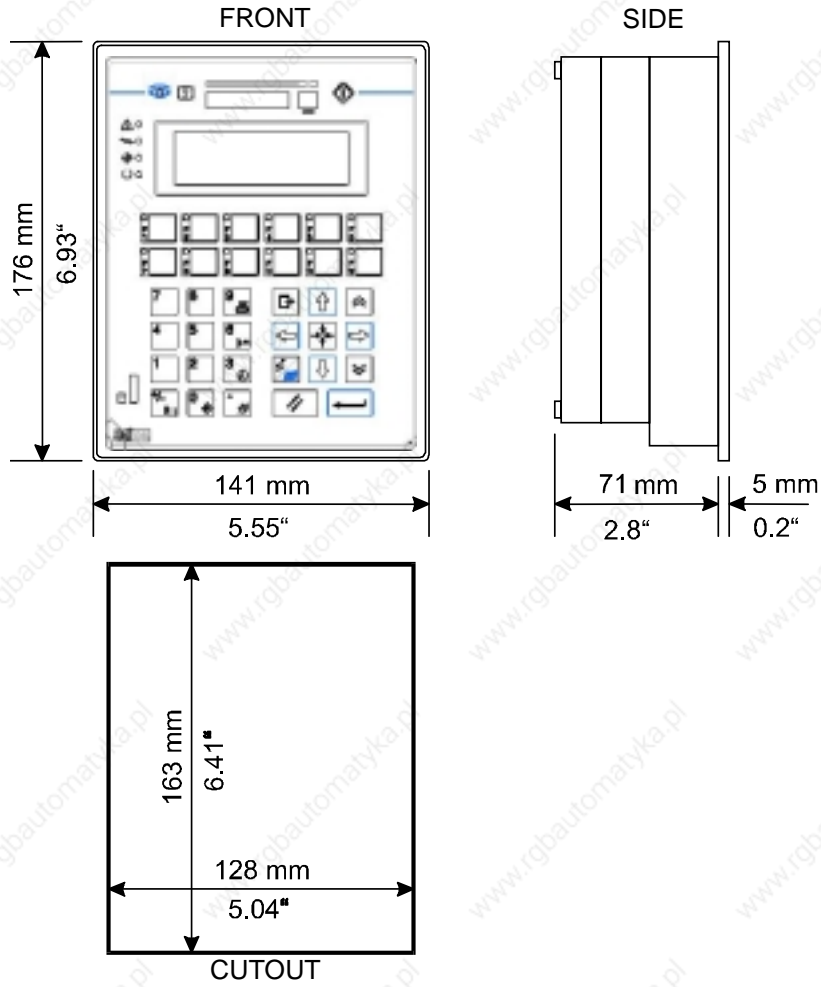

eTOP12, eTOP11, eTOP10 Dimensions

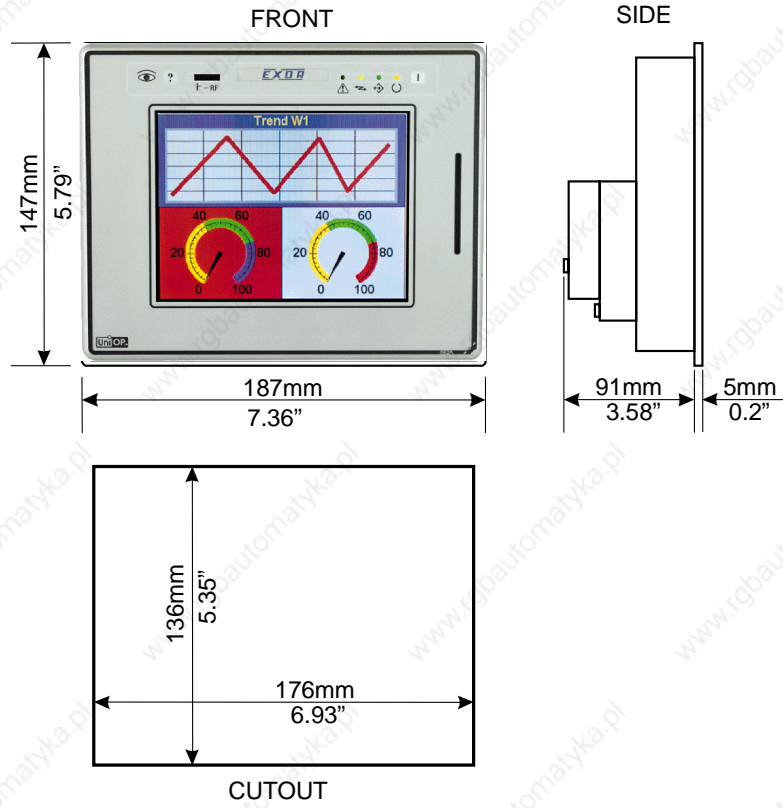

eTOP-30 Dimensions

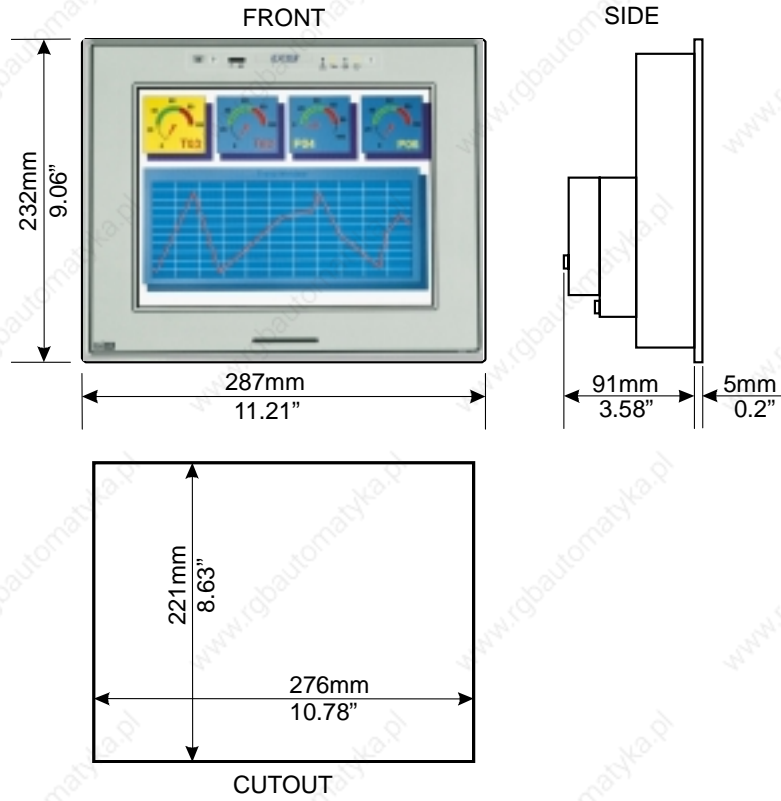

Connections
MD00R-02

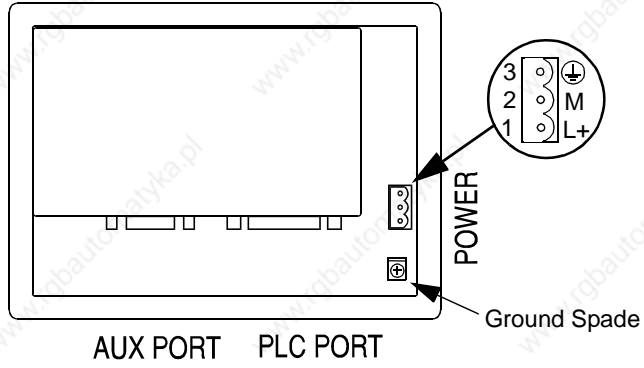

CP11G-04

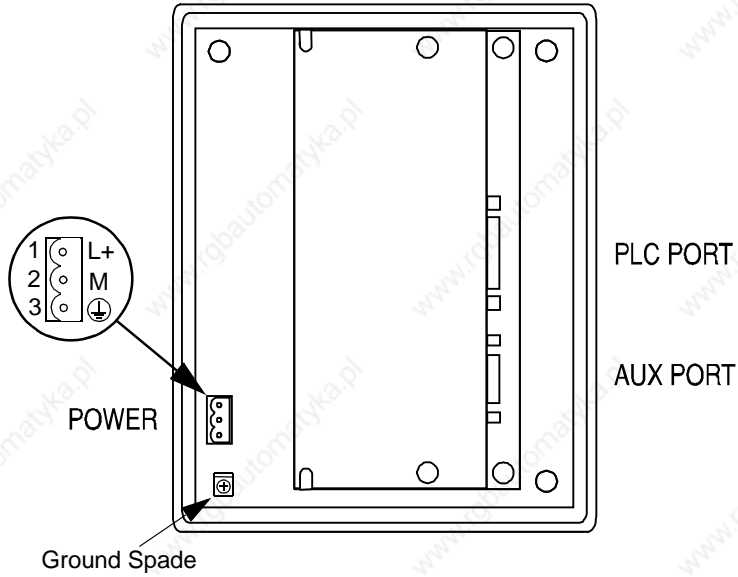

CP10G-04

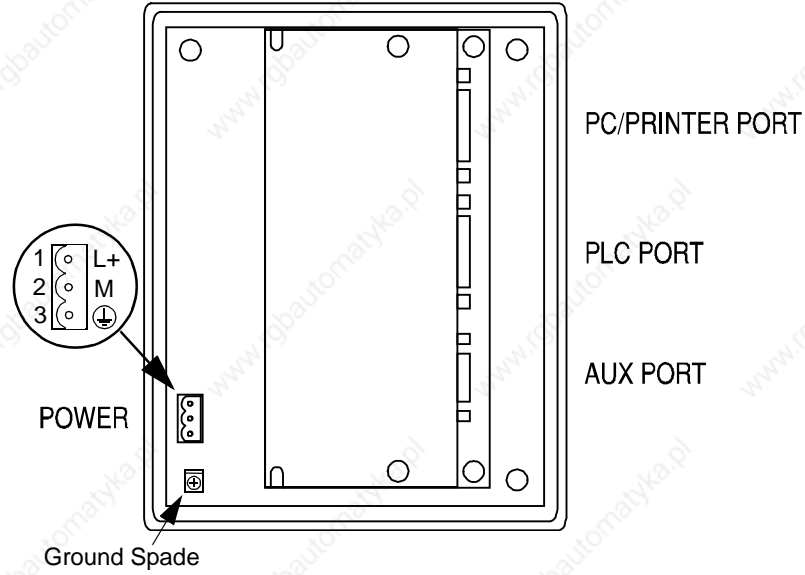

eTOP-12, eTOP-11, eTOP-10

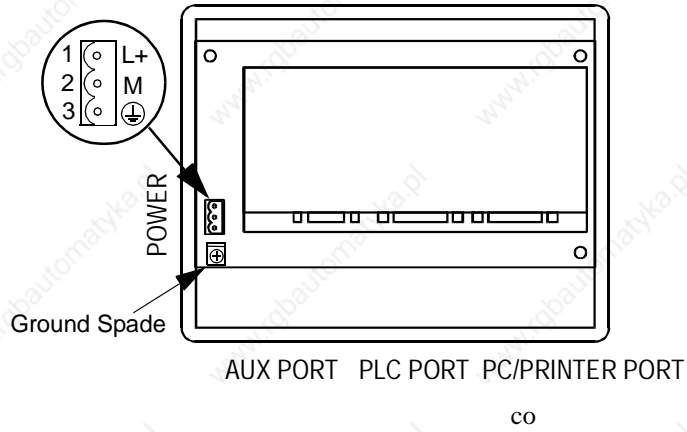

eTOP-30

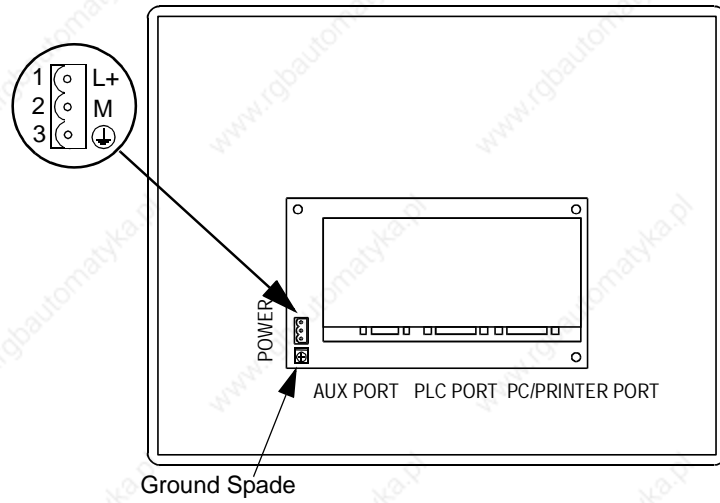

Power Supply and Grounding

The power supply terminal block is shown in the figure below. The terminal block is included with the panel.

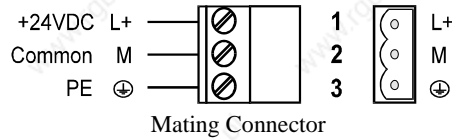

Part Number	Description	Manufacturer
BLZ 5.00/3 BK	Mating Connector 3 position / 5.0 mm pitch connector (22 to 12 AWG Wire)	Wridmuller

Note: Ensure that the power supply has enough power capacity to operate the equipment.

The unit must always be grounded to protection earth (PE). Grounding helps limit the effects of noise due to electromagnetic interference on the control system.

Earth connection must be done using either the screw or the faston terminal located near the power supply terminal block. A yellow label identifies the ground connection. Connect terminal 3 to ground on the power supply terminal block.

The power supply circuit may be floating or grounded. In the latter case connect the power source common to ground as shown by the dashed line in the figure on the following page.

When using the floating power scheme, note that the panels internally connect the power common to ground with a 1M Ω resistor in parallel with a 10nF capacitor.

The power supply must have double or reinforced insulation.



Mating Ground Spade

Part Number	Description	Manufacturer
3-520117-2	Mating Ground Spade 0.032" x 0.25" (16 to 14 AWG Wire)	Amp

Universal Operator Panels Installation Guide

The suggested wiring for the power supply is shown in the figure below.

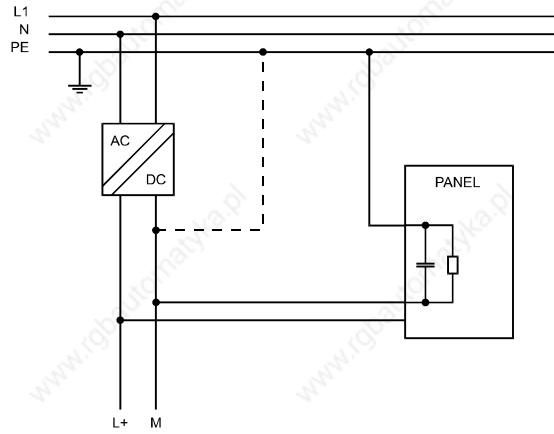

All the electronic devices in the control system must be properly grounded. Grounding must be performed according to applicable regulations.

PLC Port

The PLC Port is used to communicate with the PLC or with another type of controller; if the panel is configured as a UniNET client, this port may be used for the network connection.

Different electrical standards are available for the signals in the PLC port connector: RS-232, RS-422, RS-485, or current loop 20 mA. The cable is used to select the appropriate signals. The correct cable type must be used to connect the PLC.

Note: If the proper cable is not used, communication with the PLC will not be possible.

The connector is a D-15 pin male. Pin assignment is shown in the table below.

Pin	Description
1	Frame Ground
2	RXD
3	TXD
4	+5V output (100mA maximum)
5	GND
6	CHA-
7	CHB-
8	TX +20mA
9	TX -20mA
10	RTS
11	CTS
12	RX +20mA
13	RX -20nA
14	CHA+
15	CHB+

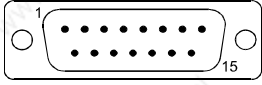

The communication cable must be compatible with the type of device being connected.

Cable Accessories

Part Number	Description
HMI-C940-10	Comm cable (MP940)
HMI-C923-11	Comm cable (MP930/920)
HMI-C600-12	Comm cable (NS600 and Sigma II)
HMI-CSMC-13	Comm cable (SMC2000)
HMI-CMOD-14	HMI Modern Cable (25 Pin Male)
HMI-CHMI-16	HMI Uni-Net Point to Point cable

MP940 & HMI RS485 Multi-drop Wiring

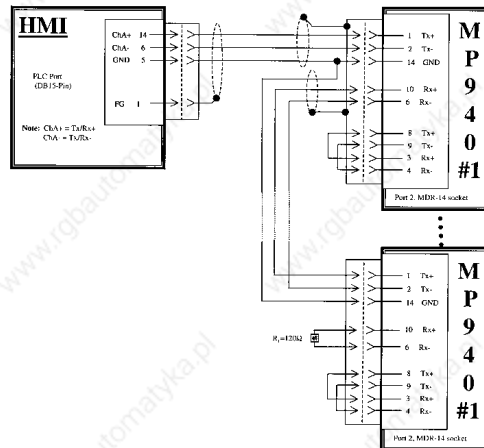

Wiring & Installation Notes

1. At cable ends, fold back shield and wrap with a thin copper tape, this will maximize contact area.
2. Cable shields at MP940 side should be placed inside the 3M connector shield clamp.
3. The last MP940 (axis N) will need a 120 Ohm terminating resistor ($R1=120$ Ohm). If noise persists, it may be necessary to tune the transmission line. Refer to Texas Instruments Application Report #SLLA070A - May 2000. In summary, it may be necessary to add the following: a terminating resistor at the HMI side, AC termination (1000pF cap in series with RT), Pull-up/pull-down resistors at HMI side, Digital Ground and Field ground resistors.
4. Max number of axis (n) = 1 to 63 (slave), Maximum cable length is 300 meters, Max transmission speed = 19.2kBaud 8-Bit Memobus RTU.
5. In the case of long cable lengths, it may be necessary to terminate the shield at the local Field Ground location for that amplifier.
6. MP940 mating connector is 14 pin, Yaskawa kit "YSC-1" includes 3M parts - Connector: 10114-3000VE and Shell: 10314-52AO-008.

HMI-C940-10

Cable Description

Cable code	HMI-C940-10 (Exor CA194)
Description	PLC Port to Yaskawa MP940
Type of Communication	RS-422
Panel Connector	D-sub type 15S
MP940	3M Connector 10314 Male
Notes	

Cable Diagram

UniOP

MP940

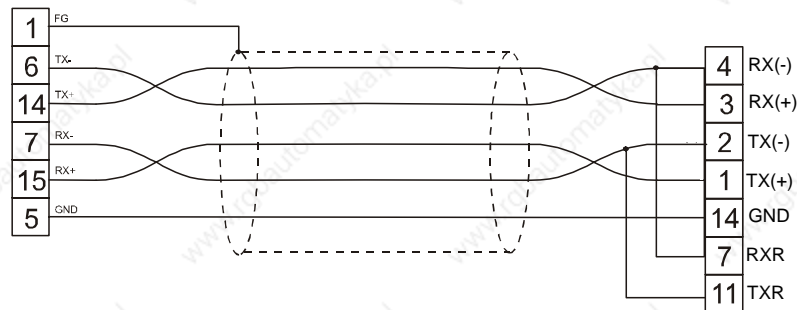

HMI-C923-11

Cable Description

Cable code	HMI-C923-11 (Exor CA44)
Description	UniOP PLC Port to DCE DE9P - RS232 (MP920 / MP930)
Type of Communication	RS-232
Panel Connector	D-sub type 15S
MP920, MP930 Connector	D-sub type 9P
Notes	

Cable Diagram

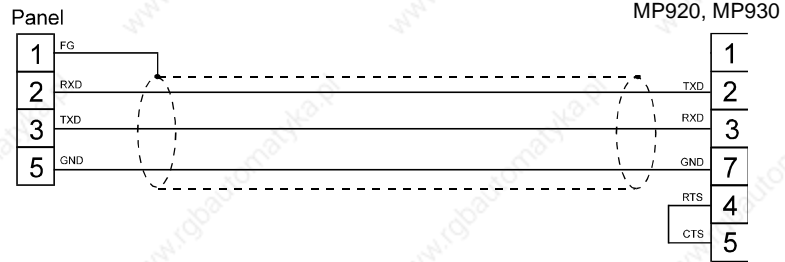

HMI-CSMC-13

Cable code	HMI-CSMC-13 (Exor CA37)
Description	UniOP PLC Port to AT RS-232 (DCE DE9S) (SMC-2000)
Type of Communication	RS-232
Panel Connector	D-sub type 15S
PLC Connector	D-sub type 9S
Notes	

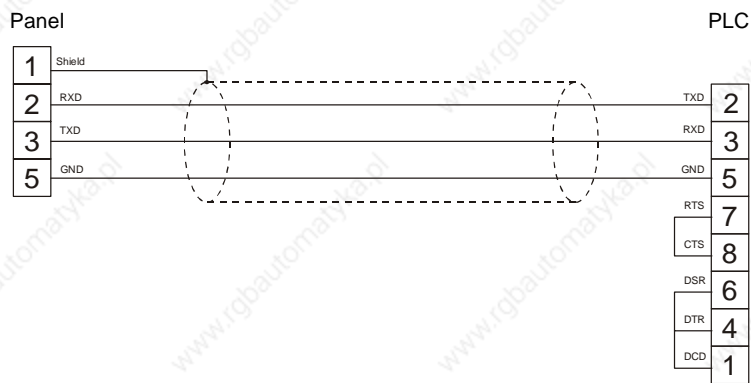

HMI-CHMI-16

Cable Description

Cable code	HMI-CHMI-16 (Exor CA118)
Description	Point to Point UniNET Connection - RS-232
Type of Communication	RS-232
Panel Connector	D-sub type 15S
PLC Connector	D-sub type 15P
Notes	For a UniNET network with only two nodes. No converters/terminal blocks required. Connects Printer Port on Server to PLC port on Client. Maximum length is 13 meters.

Cable Diagram

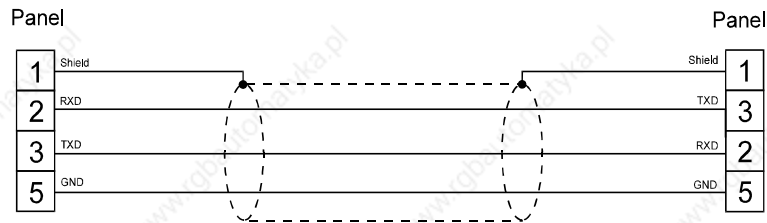

HMI-CMOD-14

Cable Description

Cable code	HMI-CMOD-14 (Exor CA148)
Description	UniOP Prog. Port to Modem
Type of Communication	RS-232
Panel Connector	D-sub type 15P
PLC Connector	D-sub type 25P
Notes	Can be used for Remote Pass through applications for Downloading/uploading projects via modem.

Cable Diagram

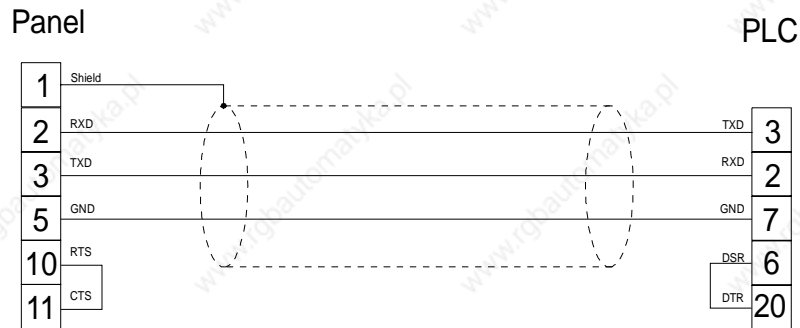

HMI-C600-12

Cable Description

Cable code	HMI-C600-12 (Exor CA198)
Description	PLC Port to Yaskawa NS-600 Indexer and Sigma II
Type of Communication	RS-232
Panel Connector	D-sub type 15S
PLC Connector	3M Connector 10314 Male
Notes	

Cable Diagram

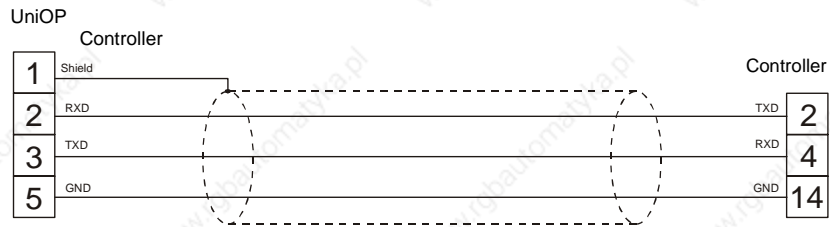

PC/Printer Port

The function of the PC/Printer Port depends on the panel mode of operation.

Configuration Mode	programming port
Operation Mode, UniNET Server	connection to UniNET
Operation Mode, UniNET not active or Client node	connection to serial printer

Only RS232 signals are available on the PC/printer port. The connector is a D-15 pin female. Pin assignment is shown in the table below.

Pin	Description
1	Frame Ground
2	RXD
3	TXD
4	+5 V output (max 100mA)
5	GND
6	Reserved
7	Reserved
8	Reserved
9	Reserved
10	RTS
11	CTS
12	Reserved
13	Reserved
14	Reserved
15	Reserved

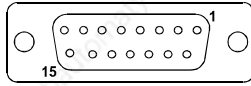

PC/PRINTER PORT

Use cable HMI-CPROG-20 (shown below) to connect the panel to a PC for programming. The connector is a D-9 pin female.

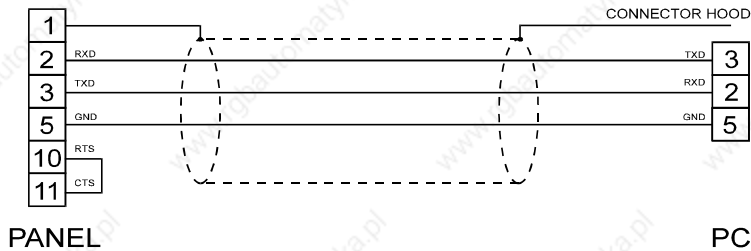

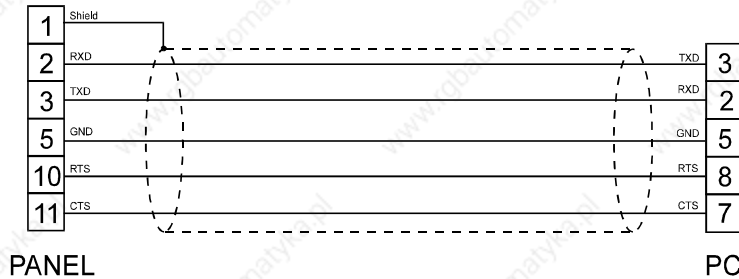

When the panel is in Operation Mode and is not used as a UniNET server, a serial printer may be attached to the PC/printer port. The communication parameters for the printer are defined by the application program (project file).

Note: The communication cable to the printer must be compatible with the communication interface of the printer.

AUX Port

The AUX port is a communication port specially designed for industrial network communication. The AUX port connector is a 9-pin D sub-type. The functionality of the AUX port depends on the optional communication module plugged into the unit.

Note: The pin assignment of the AUX port connector is described in the option section of the manual.

Note: For installation instructions, please refer to the option section of this manual.

Models without the PC/Printer Port

Some UniOP models, MDOOR-02, and CP11G do not have the PC/printer port. For these models, the PLC port will be referred to as the PLC/PC port, and will be used as a programming port when the panel is in Configuration Mode. A gender changer (DB-15) must be used with the HMI-CPROG-20 cable to program these units.

Part Number	Description	Manufacturer
2763-SPC	DB-15 Female - Female Gender Changer	Voltrex

External Keyboard Port

Several UniOP models are equipped with a connector designed to connect an external keyboard type ET-F or AT-F. The communication cable is supplied with the keyboards.

Battery Replacement

Some models require the use of the lithium battery for data back-up. The following information is maintained by the battery:

- hardware real-time clock (date and time)
- event list
- recipe data

UniOP panels signal the battery status in more than one way:

- blinking of the LED indicator FAULT or FLT (when available) or 
- with the 'Battery' field in System Menu (BATTERY OK or LOW)
- with the value of the S6 bit in the RDA

When the panel signals that the battery is low, it must be replaced as soon as possible.

Note: Replacing the battery will cause the loss of the data maintained by the battery.

To replace the battery, follow the steps below:

1. Turn off the power to the panel.
2. Use a screwdriver to loosen the four screws securing the block composed of the two metal units.
3. Remove the block.
4. Remove the battery.
5. Replace the battery with a new one.

CAUTION

There is a danger of explosion if the battery is incorrectly replaced.
Use only the same or equivalent type battery, as recommended by the manufacturer.
Dispose used batteries according to the manufacturer's instructions.

6. Replace the block; tighten the four screws.
7. Apply power to the panel and check that the *battery good* status is signaled.





Removing the Legends

The keyboard legends can be removed in one step by grasping the exposed portion of the legend (located at the bottom rear or side of the unit) and sliding it downward.

Use either the blank legends that come with the panel, or use another with equivalent thickness and consistency. Do not use legends thicker than those included in the panel.

Dedicated LEDs

The table below shows the name and the symbol (when available) of the LEDs dedicated to special functions which may be available in the UniOP operator panels.

LED		Status	Meaning
Name/symbol	Color		
FAULT/FLT	red	OFF	No hardware problem detected; battery OK
		BLINK	Battery low
		ON	Hardware fault
DL	green	OFF	No keys are pressed and no errors
		BLINK	Communication error (not all models)
		ON	While any key is pressed (visual feedback)
	red	OFF	No hardware problem detected
		BLINK	Battery low
		ON	Hardware fault
	green	OFF	No keys are pressed
		ON	While any key is pressed (visual feedback)
RUN / 	green	OFF	Hardware fault
		ON	Unit in operation
COM / 	green	BLINK	Communication error
		ON	Communication OK
ALARM / 	red	OFF	No alarms 
		BLINK	Alarm requires acknowledgment
		ON	Alarm active

Usage and Safety Guidelines

Applicable Regulations

Regulations and recommendations have been issued in Europe covering the main safety-related issues in control systems which include operator interfaces.

EN 60204-1 lists some important guidelines applicable when using operator interfaces.

9.2.4	Suspension of safeguards
9.2.5.3	Stop
9.2.5.4	Emergency stop
9.2.5.6	Hold-to-run controls
9.2.5.7	Two-hand controls
9.4	Control function in case of failure

Do not use an operator interface to directly command motors, valves or other actuators not equipped with safeguards, to avoid potential harm to persons or equipment in the event of a fault to the unit.

The units are intended to be mounted on the front panel of a metal cabinet. Service personnel, when operating directly on the powered unit, must be electrostatically discharged.

All safety related regulations must be observed.



Do not open the panel rear cover when the power supply is applied.

Installation Environment

The equipment is not intended for continuous exposure to direct sunlight. Such exposure may accelerate the aging process of the front panel film.

The equipment is not intended for installation in contact with corrosive chemical compounds. Check the resistance of the front panel film to a specific compound before installation.

Do not use tools of any kind (e.g., screwdrivers) to operate the keyboard of the panel or the touch screen.

In order to meet the front panel protection classifications, installation must follow the steps below.

- The borders of the cutout must be flat.
- Tighten each fixing screw until the plastic bezel corner contacts the panel.
- The panel cutout must be of the dimensions indicated in this manual.
- Two types of gaskets are delivered with the UniOP panels (rectangular and linear), depending on the model.

Applying the Rectangular Gasket

- The gasket must be applied around the cutout prepared for the panel (see the figure below), using care to avoid placing it under tension.
- The gasket must be replaced each time the panel is dismantled and remounted.

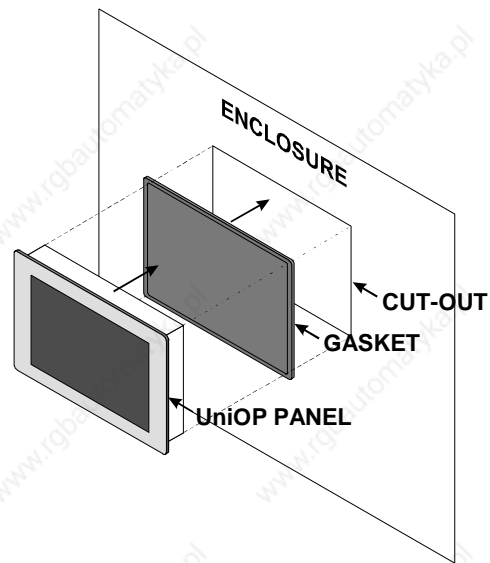

Applying the Two Linear Gaskets

Thin strip:

- The gasket must be applied around the cutout prepared for the panel. (See the figure below.)
- The gasket must be applied starting from the middle of the lower side, using care to not place it under tension.
- The two ends of the gasket must meet without overlapping.
- The gasket must be replaced each time the panel is dismantled and remounted.

Large strip:

- The gasket must be applied on the operator panel just behind the bezel.
- The gasket must be applied starting at the point indicated in the figure below, using care to not place it under tension.
- The two ends of the gasket must meet without overlapping.
- The gasket must be replaced each time the panel is dismantled and remounted.

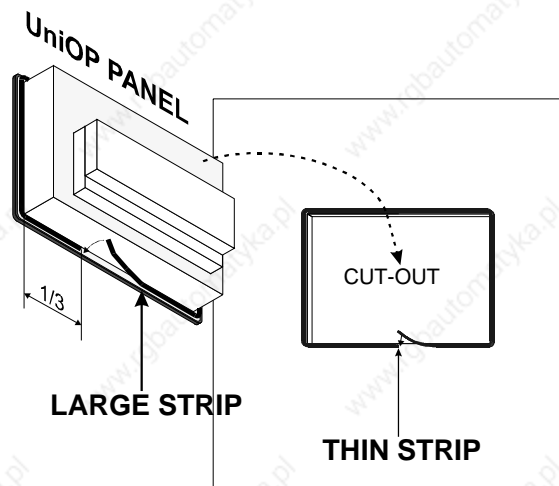

Cleaning Faceplates

Use only a soft cloth and a neutral soap product to clean the faceplates. Do not use solvents.

Getting Started

UniOP panels must be programmed using a personal computer running Designer software. The panel must be in Configuration mode to be programmed. Use the HMI-CPROG-20 cable to connect the panel to the personal computer.

Designer operates in a Windows™ environment, and must be properly installed. Windows™ is not included in the software package.

The software package can use either communication port COM1 or COM2 on the personal computer. Verify that the Designer program is correctly configured to communicate with the communication port to which the cable is attached. The communication parameters between the panel and the personal computer are:

speed:	38400 (models PC/Printer Port support also speeds of 19200 and 38400 baud)
parity:	none
stop bit:	1

The Designer software defaults to the correct parameters.

The version of Designer being used must be compatible with the firmware version of the panel to be programmed. Call for more information on compatibility between firmware and programming software.

Command Summary

The section describes the keyboard commands recognized by the UniOP panels. Commands are classified according to the operating modes of the unit.

Note: The standard command assignment is described in this section. All the commands, except those defined for Configuration Mode, can be changed, deleted and/or extended using the Keyboard Macro Editor function of the programming software.

Some models do not have a CLEAR key on the keyboard; the corresponding function can be done by pressing the right and left arrow keys at the same time.

Some models are designed to be attached to an external keyboard of type ET-F or AT-F; the commands described in this section generally refer to the use of an external keyboard

All the UniOP models have at least 4 arrow keys and the Enter key. Panels with touch screens show system-defined touch keys on the screen as required. (See the figure below.).

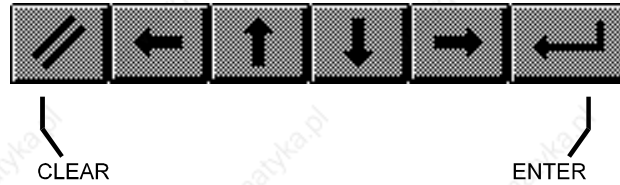

Some of the keys described in this section may not be available on each UniOP model. The functions associated with them may, however, be implemented using the Keyboard Macro Editor or using an alternative pre-defined key.

Models without numeric keypad and without touch screen allow numeric data entry using arrow keys and/or using the Keyboard Macro Editor.

Touch screen panels automatically show a numeric keypad whenever the data entry phase is activated.



Note: The term '2s' associated with a key means that the key must be held for two seconds to activate the associated function.

Configuration Mode

ENTER	Shows the type and version of the communication driver stored in the unit (if any)
ENTER 2s	Returns to Operation Mode if a valid communication driver and a valid project are stored in the unit (the key must be pressed for 2 seconds)





Operation Mode

↑	scroll page up
↓	scroll page down
←	previous page
→	next page
ENTER 2s	recall the Command Menu
0/INS	enter Data Entry Mode
Ins	enter Data Entry Mode





9/PRN	print page/cancel print
Prt Scr	print page/cancel print
ENABLE 2s	recall Direct Access Mode
6/  (2)	recall Password Insert Mode
3/  (2)	recall Date/Time Insert Mode

To recall the Configuration Mode in models ECT-16 , ELT-16 , ERT-16 and ECT-VGA touch the screen in an area where no touch cells have been defined and hold for 2 seconds.

Command Menu

	select up
	select down
	select left
	select right
ENTER	activate selection
CLEAR ⁽¹⁾	return to Page Mode

System Menu

	select up
	select down
	activate selection
	activate selection
ENTER	return to Page Mode when EXT is selected
CLEAR ⁽¹⁾	return to Page Mode

Data Entry Mode

When in Data Entry Mode, the meaning of the keys changes depending on whether or not a field has been selected for Data Entry. A field is selected when the data entry procedure has been started in that field. If the field has not already been selected for data entry, the key assignment is shown in the table below.

↑	increment digit / scroll up ASCII / select message up
↓	increment digit / scroll down ASCII / select message down
←	move cursor left in ASCII field
→	move cursor right in ASCII field
0÷9 . +/-	numeric entry
ENTER	confirm entry and return to Page Mode
CLEAR ⁽¹⁾	cancel entry and return to Page Mode

Alarm Mode

↑	previous alarm in the list
↓	next alarm in the list
ENTER 2s	acknowledge current alarm
CLEAR ⁽¹⁾	return to Page Mode
9/PRN	alarm list printout/cancel print
Prt Alm	alarm list printout/cancel print
Prt Scr	alarm list printout/cancel print

Event Mode

↑	scroll up
↓	scroll down
CLEAR ⁽¹⁾	return to Page Mode
9/PRN	event list printout/cancel print
Prt Alm	event list printout/cancel print
Prt Scr	event list printout/cancel print

Password Entry Mode

↑	increment digit
↓	decrement digit
←	next digit
0÷9	numeric password entry
ENTER	confirm password and return to Page Mode
CLEAR ⁽¹⁾	cancel entry and return to Page Mode
ESC	end entry and return to Page Mode

Time and Date Set Mode

↑	increment field value
↓	decrement field value
ENTER	field select
CLEAR ⁽¹⁾	return to Page Mode

Direct Page Selection Mode

↑	decrement page
↓	increment page
0÷9	page number entry
ENTER	confirm entry and go to selected page
CLEAR ⁽¹⁾	cancel entry and return to Page Mode

Direct Access Mode

↑	decrement offset
↓	increment offset
0÷9	numeric offset entry
ENTER	select next, confirm offset entry
CLEAR ⁽¹⁾	cancel numeric offset entry end return to Page Mode
T	select timers
Z	select counters
E	select digital inputs
A	select digital outputs
M	select flags/markers
ENABLE	return to Page Mode

Note:

- (1) Equivalent to the ESC/  key, when available
- (2) Available only in model CP10G-04.

Troubleshooting

If the operator panel cannot be switched to Configuration Mode due to problems in the start-up phase, follow the steps below:

1. Switch off the unit.
2. Press and hold any 3 keys.
3. Turn on the unit and continue holding the 3 keys until Configuration Mode is shown on the screen.

For keyless models such as the ETOP-10, ETOP-11, ETOP-12, ETOP-30, follow the steps below:

1. Switch off the unit.
2. Touch anywhere in the middle of the left side of the display screen.
3. Switch on the operator panel and tap anywhere in the middle of the right side of the display screen for approximately one second.
4. Continue until the screen shows the Configuration Mode.

Touchscreen Calibration

Standard calibration:

1. Recall the Configuration Mode.
2. Touch the CLEAR key on the screen until a small round symbol appears on the top right corner of the screen.
3. Touch the symbol until it moves to the low left corner of the screen.
4. Touch the symbol until the indication to touch the ← key is displayed on the screen.
5. Touch and hold the ← key until the indication to touch the ↓ key is displayed on the screen.
6. Touch and hold the ↓ key until the indication to touch the Enter key is displayed on the screen.
7. Touch and hold the Enter key until the panel switches to Operation Mode (if a valid project is loaded in the memory).

Emergency Calibration

The emergency calibration procedure should be used whenever use of the standard procedure is not possible. Follow the steps below.

1. Switch off the unit.
2. Turn on the unit.
3. Tap in the middle of the touchscreen every second until the operator panel enters the Calibration Mode.
4. Perform the standard calibration procedure.

Field Firmware Upgrade Guide

The following items are required to upgrade the firmware of a UniOP panel:

- A computer with one available RS-232 communications port
- A programming cable (HMI-CPROG-20)
- The UNIDL.EXE download utility, along with the executable files BE.EXE and ASK.EXE and the UL.BAT file
- The bootstrap portion of the firmware (a file named FWT3BLxx.BIN, where xx are integers)
- The download portion of the firmware (a file named FWT3DLxx.BIN, where xx are integers)

Models and their Respective Firmware Codes

Model Number	Boot Firmware File	Downloadable Firmware File
MD00R-02	FWT3BL32.BIN	FWT3DL32.BIN
CP10G-04	FWT3BL32.BIN	FWT3DL32.BIN
CP11G-04	FWT3BL32.BIN	FWT3DL32.BIN
eTOP10	FWT3BL38.BIN	FWT3DL38.BIN
eTOP11	FWT3BL38.BIN	FWT3DL38.BIN
eTOP12	FWT3BL38.BIN	FWT3DL38.BIN
eTOP30	FWT3BL58.BIN	FWT3DL58.BIN

Running the UNIDL Program and Downloading Firmware

To run the UNIDL program, ensure that the UL.BAT file, the boot firmware file, the downloadable firmware file, the executable files BE.EXE and ASK.EXE, and the UNIDL.EXE file are all in the same directory. Also, ensure that the UniOP is in Configuration Mode.

To download the boot firmware for a unit, simply type UL, followed by the filename of the boot firmware file (listed in the above chart). You will then be asked to enter a selection – choose M to load the boot portion of the firmware.

To download the downloadable firmware for a unit, simply type UL, followed by the filename of the downloadable firmware file (listed in the above chart). You will then be asked to enter a selection – choose 5 to load the downloadable portion of the firmware.

The UL Batch File

The UL batch file has several components, all of which are described below. A common line in the batch file may look like this:

```
UNIDL -c1 -d6 -m5 -t80 -b128 -o100 -y0 -x9 -r3 %1
```

Switch	Description
-c	Selects the COM port to use for downloading; 1=COM1, 2=COM2
-d	Selects the type of file you are downloading; 1=Application, 2=Project, 3=System, 4=Recipe, 5=Firmware, 6=XILINX ROM, 8=TCATIO, 9=SSFDC
-m	Selects the memory area to which you are downloading; 1=FW, 2=Internal, 3=External, 4=SEEPROM, 5=XILINX Flash, 6=TCATIO
-t	Selects the type of memory to which you are downloading; 0=Normal, 80=Flash AMD
-b	Selects the block size to download. This is fixed at 128
-o	Selects the time-out period for communication; 1=0.1 seconds, 200=20 seconds. The default is set to 10 (1 second).
-y	Selects the protocol; 0=AS51 protocol, 1=DFP protocol
-x	Selects the baud rate of the communication port; 1=150, 2=300, 3=600, 4=1200, 5=2400, 6=4800, 7=9600, 8=19200, 9=38400, 10=57600
-r	Selects the number of retries; available values are 1 through 10. The default setting is 1.

There are only two options in the UL batch file that may require modification: the -c switch for the COM port, and the -x switch for the baud rate.

Universal Operator Panels Installation Guide

Notes:

Options

Part Number	Description
TCM-10	Ethernet Module
TCM-08	Profibus
TCM-03	Devicenet
SCM-03	PLC Module
UIM-03	I/O Module* (16DI, 16DO)
UIM-05	I/O Module* (20DI, 12DO)
MEM-08	SSFDC Memory Card, 8M
MEM-16	SSFDC Memory Card, 16M

*Note that the UniWin Software from Exor will include several other items specific to YEA products

TCM10 Ethernet Communication Model

Description

The TCM10 communication module is an interface designed to connect the operator panel to Ethernet 10 BASE-T (unshielded twisted pair) LAN.

Communication is through the AUX port and the dedicated adapter ETAD01. Technical data is listed in the table below:

Connection	Ethernet
Speed	10Mbit
Insulation	Insulation Transformer

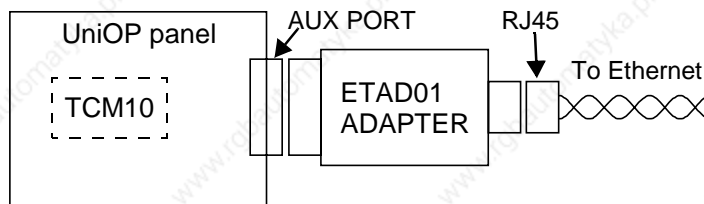

Compatibility

The TCM10 module is compatible with all operator panels which have Firmware (FW) release: FW32, FW38, FW58.

Wire Connections

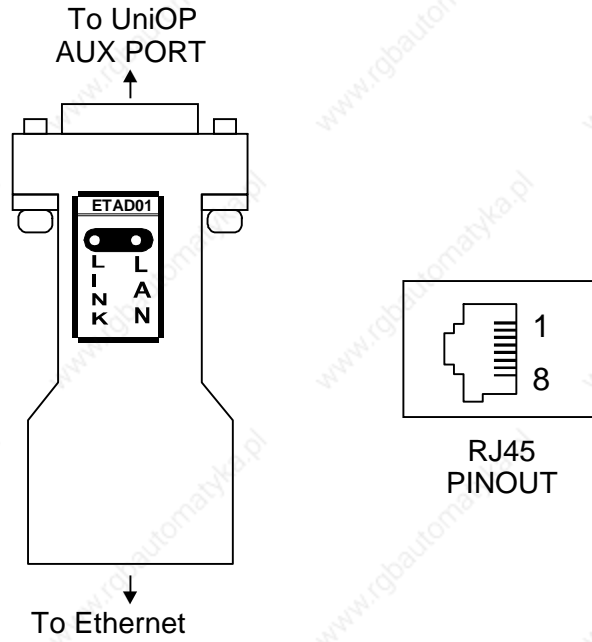

Connect unshielded twisted pair wires on RJ45 using the connection below.

Pin	Signal
1	TD out +
2	TD out -
3	RX in +
6	RX in -

Mounting the TCM10 Ethernet Communication Module

The mounting procedure for the module is as follows:

1. Turn off the operator panel.
2. Partially unscrew the two screws (“A”) on the rear cover.
3. Remove the rear cover.
4. Plug the red connectors into the module, making sure they are properly latched.
5. Replace the rear cover.
6. Screw in the screws “A”.
7. Affix the label (indicating the type of module used) to the rear cover.

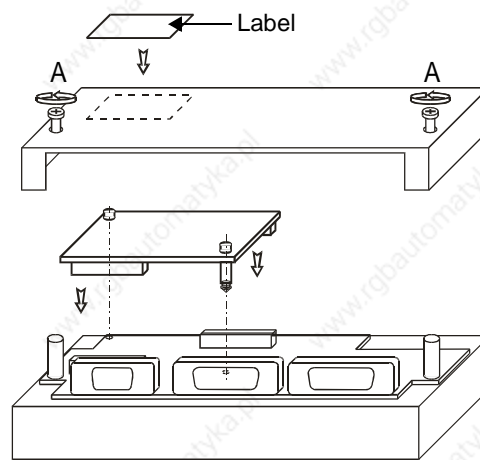

Installing the adapter

1. Plug the ETAD01 9-pin connector into the AUX port on the rear side of the panel.
2. Attach the ETAD01 adapter to the panel with the two screws on the 9-pin connector (type SUB-D).

Diagnostics

The system provides some diagnostic information on the operation of the communication modules. To access the diagnostic information:

- Recall the System Menu from the Operation Mode.
- Scroll down to display the bottom row of the page.
- The diagnostic information will be shown as in the following example.

TCM10 0 H150 x121

Type of communication module	TCM10
Internal version codes	0 H150 X121
Confirmation of the correct insertion of the module	OK

The system also provides visual diagnostics via two LEDs on the ETAD01 adapter, as follows:

LAN (green LED): LED blinks if net activity has been detected.

LINK (red LED): LED is on if no network signals have been detected, or when there is a general failure of the TCM10.

TCM08 Profibus DP Connection Module

Description

The TCM08 communication module is a Profibus DP interface designed to connect the operator panel to the Profibus DP network. Communication is through the AUX port. Technical data is listed in the table below.

Communication protocol	Profibus DP
Max speed	12Mbit
Optical insulation	Yes

The AUX port and pin assignment are shown below.

Pin	Description
1	PE
2	
3	RXD / TXD (B)
4	RTS
5	M 5V2
6	P 5V2
7	
8	RXD / TXD (A)
9	

PLC PORT

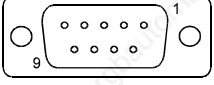

Note: Communication with the PLC is not possible if the proper cable is not used.

Compatibility

The TCM08 module is compatible with all operator panels which have suffix -0045 in the part number.

Mounting the TCM08 Profibus DP Communication Module

The mounting procedure for the module is the following:

1. Turn off the operator panel.
2. Partially unscrew the two screws ("A") on the rear cover.
3. Remove the rear cover.
4. Plug the red connectors into the module, making sure they are properly latched.
5. Replace the rear cover.
6. Screw in the screws "A".

7. Affix the label (indicating the type of module used) to the rear cover.

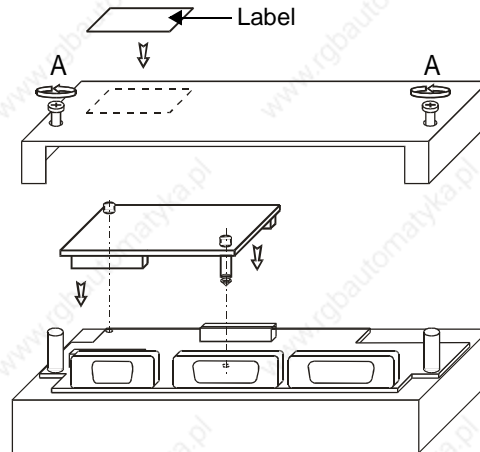

Diagnostics

The system provides some diagnostic information on the operation of the communication modules. To access the diagnostic information:

- Recall the System Menu from the Operation Mode.
- Scroll down to display the bottom row of the page.
- The diagnostic information is shown as in the example below.

TCM08 0 H010 x010

Type of communication module	TCM08
Internal version codes	0 H010 X010
Confirmation of the correct insertion of the module.	OK

TCM03 DeviceNet Connection Module

Description

The communication module is an interface designed to let the operator panel connect to the DeviceNet network. The communication will be through the AUX port. The technical data is listed in the table below:

Communication protocol	DeviceNet
Max speed	500 Kbit
Optical insulation	Si

The AUX port and pin assignment are shown below.

Pin	Description	
1		<p style="text-align: center;">PLC PORT</p>
2	CAN-	
3	V-	
4		
5	SHIELD(RC)	
6		
7	CAN+	
8		
9	V+	

Note: Communication with the PLC is not possible if the proper cable is not used.

Compatibility

The TCM03 module is compatible with all operator panels which have suffix -0045 in the part number.

Mounting the TCM03 DeviceNet Port Communication Module

The mounting procedure for the module is as follows.

1. Turn off the operator panel.
2. Partially unscrew the two screws ("A") on the rear cover.
3. Remove the rear cover.
4. Plug the red connectors into the module, making sure they are properly latched.
5. Replace the rear cover.
6. Screw in the screws "A".

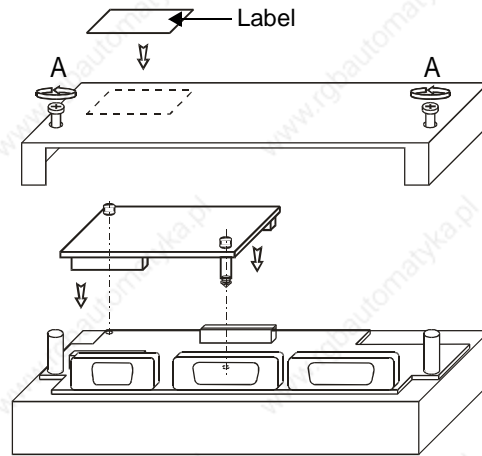

Diagnostics

The system provides some diagnostic information on the operation of the communication modules. To access the diagnostic information:

- Recall the System Menu from the Operation Mode.
- Scroll down to display the bottom row of the page.
- The diagnostic information is shown as in the example below.

TCM03 0 H030 x030

Type of communication module	TCM03
Internal version codes	0 H030 X030
Confirmation of the correct insertion of the module.	OK

SCM03 PLC Module

Description

The SCM03 is a high performance universal communication module. This module has a local (incorporated) CAN network controller which is driven and controlled by MIPS software that runs locally on the SCM03 board. The SCM03 works as an autonomous CAN node, sending/receiving data packets to/from the CAN network. The SCM03 is connected to the UniOP (master) via local internal serial bus (SMUX PB). The SCM03 is a communication controller, charged to perform CAN protocol and any other tasks defined by the UniOP.

Technical Characteristics

CPU	79RV3041 Idt Risc processor
Clock speed	24Mhz
Flash memory	1Mbyte
Sdram memory	2Mbyte
FPGA Xilinx Spartan	SCS30XL (15000gates)
CPU supervisor (Reset, Watchdog)	Yes
Serial Eeprom memory	25F256
Interface No. 1 Internal serial bus	SMUX PB
Interface No. 1 Isolated Fieldbus	CAN

In typical applications, one UniOP, SCM03 will provide CAN OPEN (1Mbit maximum, with optical insulation) via AUX port. Connection of pins on DB9 connector of AUX port is presented below.

Pin	Description
1	
2	CAN_L
3	
4	
5	(CAN_SHIELD)*
6	CAN_GND
7	CAN_H
8	
9	

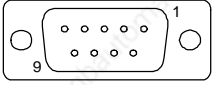

* CAN_SHIELD is connected via 1M Ω and 3,3nF to shield.

Diagnosics

The system provides some diagnostic information of the communication modules on the operation panels. To access the diagnostic information:

- Recall the System Menu from the Operation Mode
- Scroll down to display the bottom row of the page
- The diagnostic information is shown as in the example below:

SCM03

Type of communication module	SCN03
Internal version codes	0 H160 X130
Confirmation of the correct insertion of the module.	OK

Mounting the Module

The mounting procedure is as follows:

1. Turn off the operator panel.
2. Partially unscrew the two screws (“A”) on the rear cover.
3. Remove the rear cover.
4. Plug the red connectors into the module, making sure they are properly latched.
5. Replace the rear cover.
6. Screw in the screws “A”.
7. Affix the label (indicating the type of module used) to the rear cover.

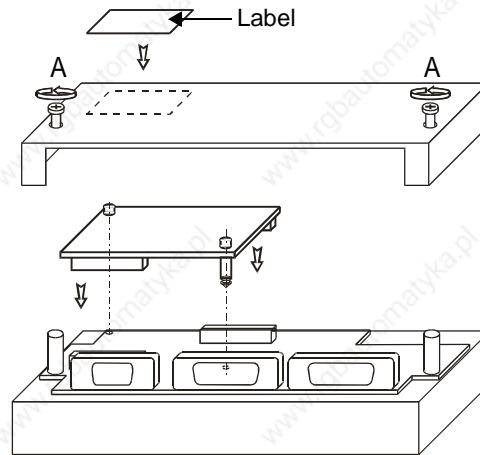

UIM03 Discrete I/O Modules

Reference Products

- UIM03 16 digital input, 16 digital output

Specifications

Inputs

Description	Specifications
Number	16
Type	Optoisolated (industrial standard) active high (+24VDC) inputs. Group of 4 inputs has common return line (M1+M4)
Voltage for Condition ON	12+30VDC (mini 3mA) nominal 24VDC/6mA maximum 35V (500ms)
Maximum voltage for Condition OFF	4VDC, 0.8mA
Isolation	1500Vrms
Connector type	MINI-COMBICON plugs 3.5mm - 4 contacts (2-piece terminal blocks) MC 1.5/4 ST 3.5
Hardware filter	10KHz

Outputs:

Description	Specifications
Number	16
Type	Relay single contact (normal OPEN)
Maximum continuous current	1A
Maximum switching voltage	DC:42V, AC:30V
Isolation	CONTACT/COIL: 1000V OPEN CONTACTS: 500V
Short circuit protection	No
Connector type	MINI-COMBICON plugs 3.5mm - 8 contacts (2 piece terminal blocks) MC 1.5/8 ST 3.5

Environmental Conditions

Description	Specifications
Operating temperature	0 ÷ +50°C
Storage temperature	-20 ÷ +70°C
Operating humidity	5 ÷ +95% relative humidity, non-condensing

Connector View

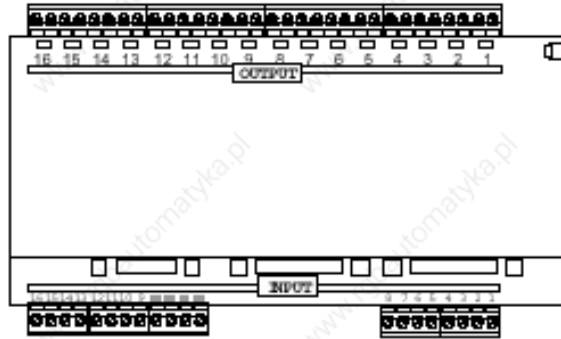

Module Block Diagram

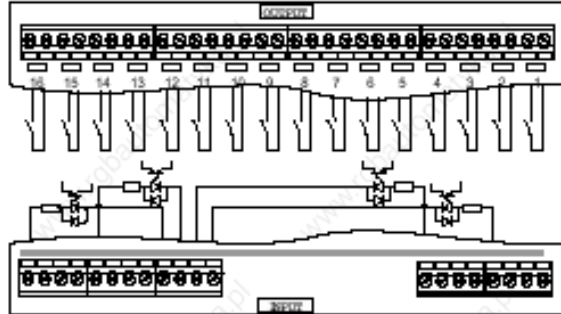

Installing the UIM03 I/O Module

The mounting procedure for the module is as follows below. Required tools are a 4mm diameter Phillips screwdriver, 4mm tip flathead screwdriver, and a 7mm wrench.

1. Turn off the operator panel, and remove all cables.
2. Partially unscrew the four screws (A, B, C, and D).
3. Remove the rear cover.
4. Insert the UIM03 module.
5. Attach the UIM03 module with the two screws (E and F).
6. Plug the UIM03 internal flat cable connector into the red connector, ensuring they are properly latched.
7. Remove the three-side protection from the steel rear box.
8. Replace the rear cover. Tighten screws A, B, C, and D.
9. Affix the labels indicating the UIM03 pin assignment.

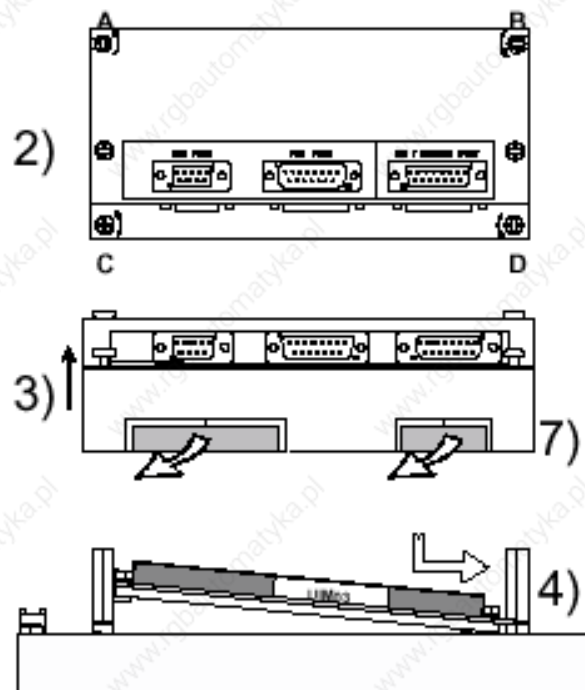

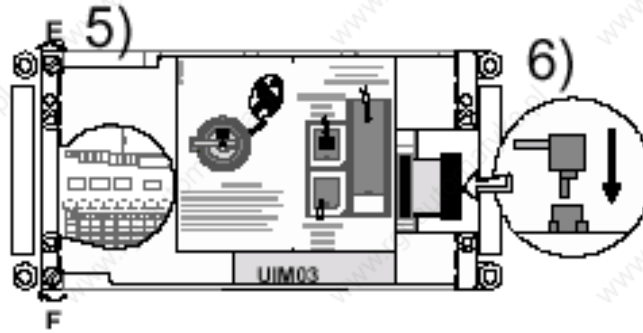

9)

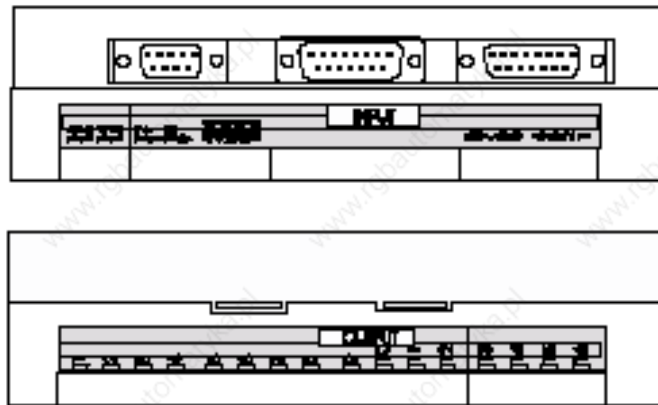

UIM05 Discrete I/O Modules

Reference Products

- UIM05 20 digital input, 12 digital output

Specifications

Inputs

Description	Specifications
Input Channels	20
Type	Optoisolated (industrial standard) source active high (+24VDC) inputs. All inputs are internally connected to OVDC of power supply.
Voltage for Condition ON	12+30VDC (min 3mA) nominal 24VDC/6mA maximum 35V (500ms)
Maximum voltage for Condition OFF	4VDC, 0.8mA
Isolation	1500Vrms
Connector type	MINI-COMBICON plugs 3.5mm - 8 contacts (2-piece terminal blocks) MC 1.5/8 ST 3.5
Input Frequency	10KHz

Outputs:

Description	Specifications
Output Channels	12
Type	Optoisolated outputs
Maximum continuous current	0.7A (1.4Amax)
Maximum switching voltage	12-30VDC
Isolation	1500 Vrms
Short circuit protection	No
Connector type	MINI-COMBICON plugs 3.5mm - 8 contacts (2 piece terminal blocks) MC 1.5/8 ST 3.5

Environmental Conditions

Description	Specifications
Operating temperature	0 ÷ +50°C
Storage temperature	-20 ÷ +70°C
Operating humidity	5 ÷ +95% relative humidity, non-condensing

Encoder Channels

Description	Specifications
Encoder channels	4 (Phase A, Phase B, Zero encoder and Machine zero index pulse inputs per channel). All inputs are internally connected to 0VDC of power supply.
A & B & Z & M channel inputs	IN1 & IN2 & IN3 & IN4 & IN5 & IN6 & IN7 & IN8, IN9 & IN10 & IN11 & IN12, & IN13 & IN14 & IN15 & IN16
Input frequency	10 KHz max, 1.2Hz min
Pulse width	50 μ s min
Count range	32 bit

Counter Inputs

Description	Specifications
Counter channels	4 (Pulse and gate input per channel). All inputs are internally connected to 0VDC of power supply. The gate input enables the count of input pulses; the count could be enabled only by SW (so the gate input is available as a general digital input)
Pulse & gate input pairs	IN1 & IN2, & IN5 & IN6, IN9 & IN10, & IN13 & IN14
Input frequency	10 KHz max, 1.2Hz min
Pulse width	50 μ s min
Count range	32 bit

Frequency Inputs

Description	Specifications
Frequency channels	4 (one input per channel). All inputs are internally connected to 0VDC of power supply.
Frequency inputs	IN1, IN5, IN9, IN13
Input frequency	10 KHz max, 1.2Hz min
Pulse width	50 μ s min
Accuracy	0.0015%

Analog Outputs

Description	Specifications
Output channels	4 analog output not isolated channels (voltage or current output).
Resolution	12 bit
Output voltage type	Single-ended
Output voltage range	0÷10VDC
Output voltage load impedance	1K minimum
Output voltage load capacitance	10nF max
Output voltage linearity error	TBD
Output current type	Current source
Output current range	0÷
Output current load impedance	
Output current linearity error	
Connector type	

Connector View

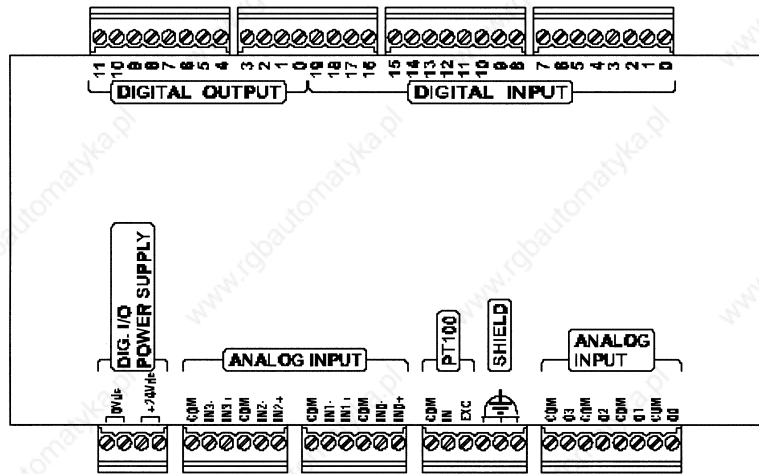

Encoder Channels

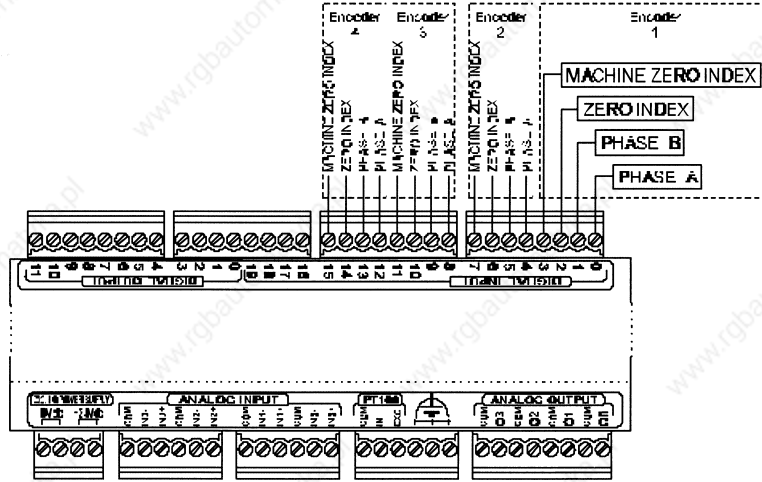

Counter and Frequency Inputs

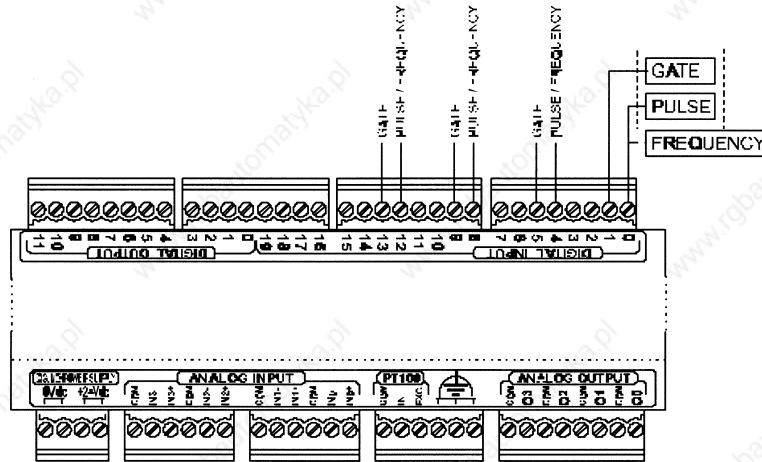

Installing the UIM05 I/O Module

The mounting procedure for the module is as follows below. Required tools are a 4mm diameter Phillips screwdriver, 4mm tip flathead screwdriver, and a 7mm wrench.

UIM05

1. Turn off the operator panel, and remove all cables.
2. Partially unscrew the four screws (A, B, C, and D).
3. Remove the rear cover.
4. Insert the UIM05 module.
5. Attach the UIM05 module with the two screws (E and F).
6. Plug the UIM05 internal flat cable connector into the red connector, ensuring they are properly latched.
7. Remove the three-side protection from the steel rear box.
8. Replace the rear cover. Tighten screws A, B, C, and D.
9. Affix the labels indicating the UIM05 pin assignment.

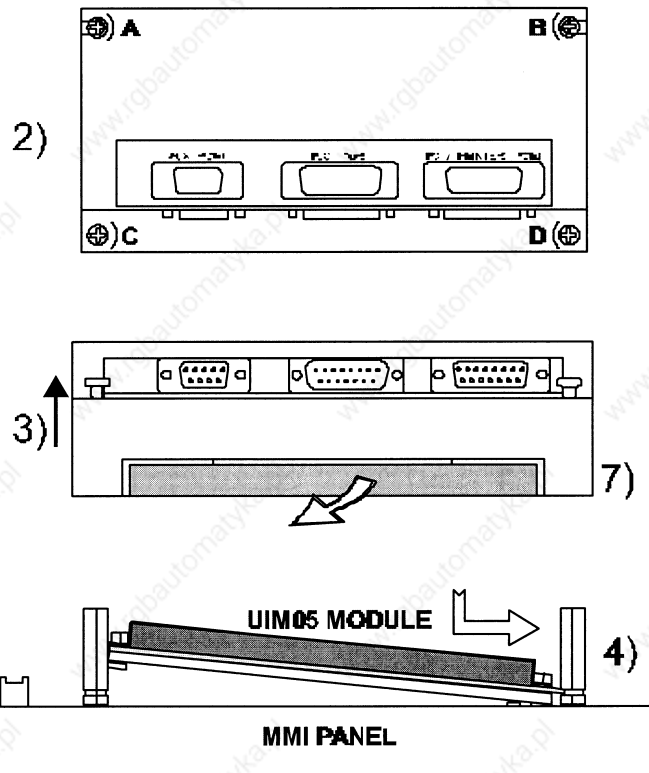

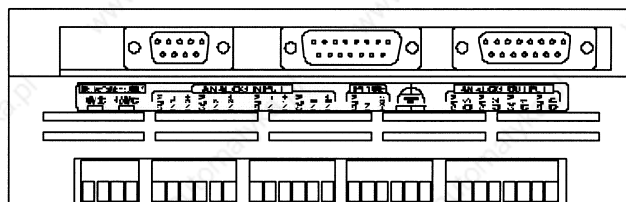
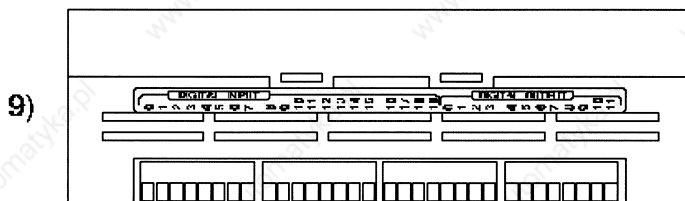
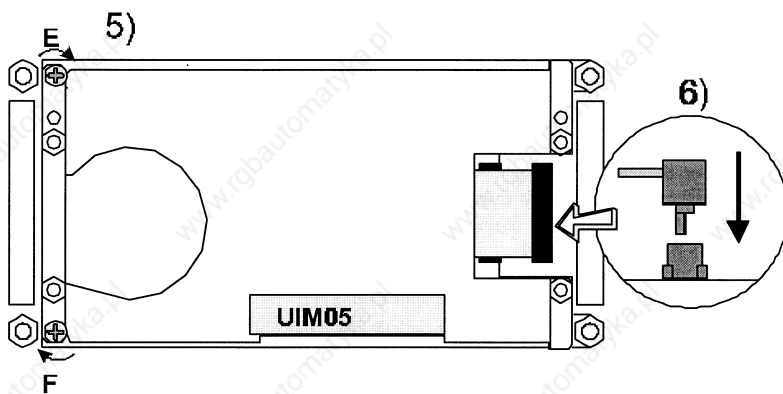

Mem-08/16 Memory Card

The SSFDC (Solid State Floppy Disc Card) is a very small (37mmx45mmx0.76mm) and lightweight (2g) flash memory card. Because of its simple structure, it is highly portable making it an ideal removable data storage medium.



Part Number	Description
MEM-08	SSFDC Memory Card, 8M
MEM-16	SSFDC Memory Card, 16M



YASKAWA ELECTRIC AMERICA, INC.

Chicago-Corporate Headquarters 2121 Norman Drive South, Waukegan, IL 60085, U.S.A.
Phone: (847) 887-7000 Fax: (847) 887-7310 Internet: <http://www.yaskawa.com>

MOTOMAN INC.

805 Liberty Lane, West Carrollton, OH 45449, U.S.A.
Phone: (937) 847-6200 Fax: (937) 847-6277

YASKAWA ELECTRIC CORPORATION

New Pier Takeshiba South Tower, 1-16-1, Kaigan, Minatoku, Tokyo, 105-0022, Japan
Phone: 81-3-5402-4511 Fax: 81-3-5402-4580 Internet: <http://www.yaskawa.co.jp>

YASKAWA ELETRICO DO BRASIL COMERCIO LTDA.

Avenida Fagundes Filho, 620 Bairro Saude Sao Paulo-SP, Brasil CEP: 04304-000
Phone: 55-11-5071-2552 Fax: 55-11-5581-8795 E-mail: yaskawabrasil@originet.com.br

YASKAWA ELECTRIC EUROPE GmbH

Am Kronberger Hang 2, 65824 Schwalbach, Germany
Phone: 49-6196-569-300 Fax: 49-6196-888-301

MOTOMAN ROBOTICS AB

Box 504 S38525, Torsas, Sweden
Phone: 46-486-48800 Fax: 46-486-41410

MOTOMAN ROBOTEC GmbH

Kammerfeldstraße 1, 85391 Allershausen, Germany
Phone: 49-8166-900 Fax: 49-8166-9039

YASKAWA ELECTRIC UK LTD.

1 Hunt Hill Orchardton Woods Cumbernauld, G68 9LF, Scotland, United Kingdom
Phone: 44-12-3673-5000 Fax: 44-12-3645-8182

YASKAWA ELECTRIC KOREA CORPORATION

Paik Nam Bldg. 901 188-3, 1-Ga Euljiro, Joong-Gu, Seoul, Korea
Phone: 82-2-776-7844 Fax: 82-2-753-2639

YASKAWA ELECTRIC (SINGAPORE) PTE. LTD.

Head Office: 151 Lorong Chuan, #04-01, New Tech Park Singapore 556741, SINGAPORE
Phone: 65-282-3003 Fax: 65-289-3003

TAIPEI OFFICE (AND YATEC ENGINEERING CORPORATION)

10F 146 Sung Chiang Road, Taipei, Taiwan
Phone: 886-2-2563-0010 Fax: 886-2-2567-4677

YASKAWA JASON (HK) COMPANY LIMITED

Rm. 2909-10, Hong Kong Plaza, 186-191 Connaught Road West, Hong Kong
Phone: 852-2803-2385 Fax: 852-2547-5773

BEIJING OFFICE

Room No. 301 Office Building of Beijing International Club,
21 Jianguomenwai Avenue, Beijing 100020, China
Phone: 86-10-6532-1850 Fax: 86-10-6532-1851

SHANGHAI OFFICE

27 Hui He Road Shanghai 200437 China
Phone: 86-21-6553-6600 Fax: 86-21-6531-4242

SHANGHAI YASKAWA-TONJI M & E CO., LTD.

27 Hui He Road Shanghai 200437 China
Phone: 86-21-6533-2828 Fax: 86-21-6553-6677

BEIJING YASKAWA BEIKE AUTOMATION ENGINEERING CO., LTD.

30 Xue Yuan Road, Haidian, Beijing 100083 China
Phone: 86-10-6232-9943 Fax: 86-10-6234-5002

SHOUGANG MOTOMAN ROBOT CO., LTD.

7, Yongchang-North Street, Beijing Economic & Technological Development Area,
Beijing 100076 China
Phone: 86-10-6788-0551 Fax: 86-10-6788-2878

YEA, TAICHUNG OFFICE IN TAIWAN

B1, 6F, no.51 Section 2, Kung-Yi Road, Taichung City, Taiwan, R.O.C.
Phone: 886-4-2320-2227 Fax: 886-4-2320-2239