

EDBMB935X
13267960

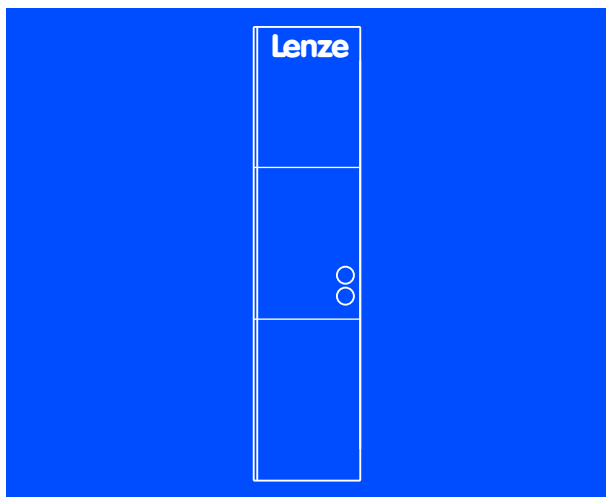

Operating Instructions

9350



EMB9351-E, EMB9352-E, EMB9351-C, EMB9352-C

Braking unit

Lenze



Please read these instructions before you start working!
Follow the enclosed safety instructions.

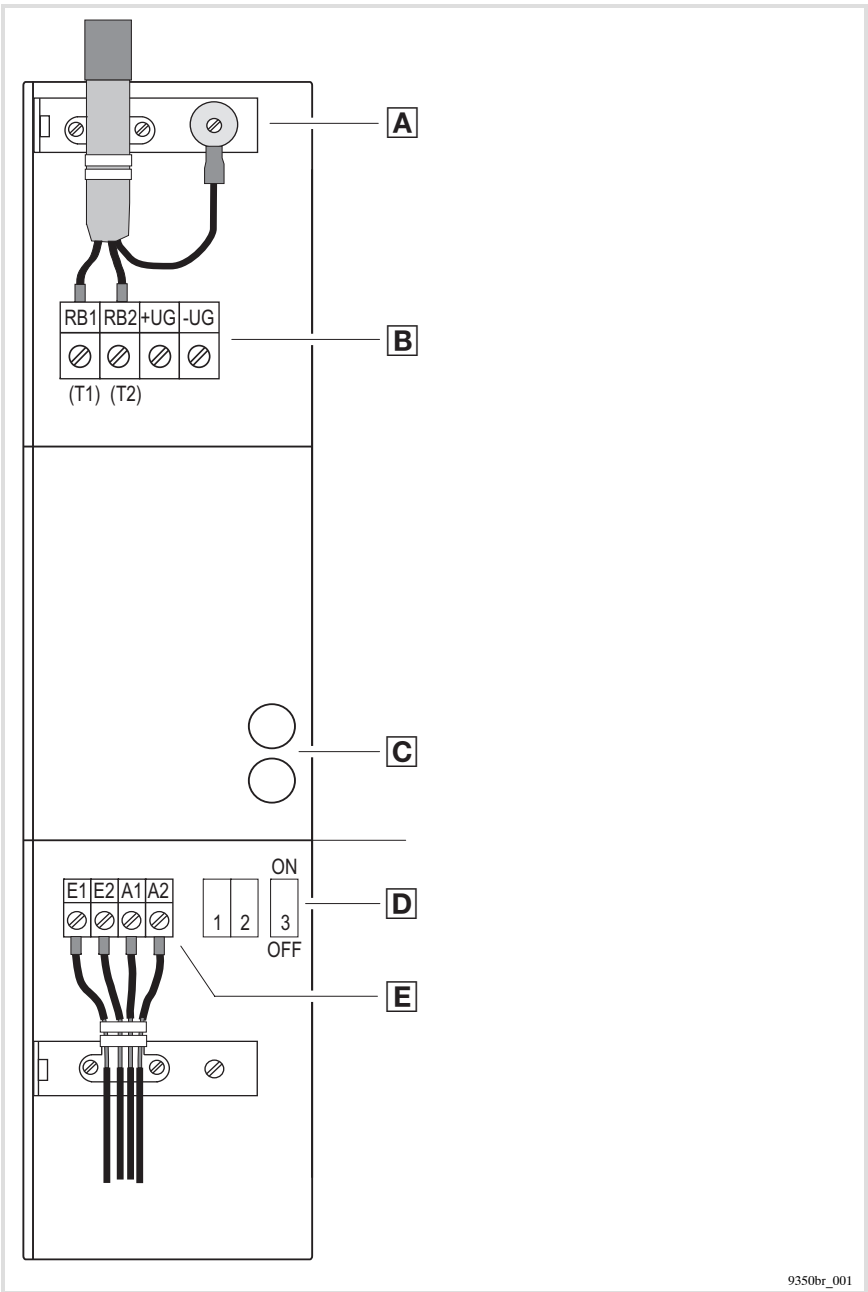

Scope of supply

Pos.	Description
Ⓐ	9350 braking unit
	Accessory kit with shield sheets and fixing material
	Operating Instructions

Elements of the braking unit

Pos.	Description		
Ⓑ	Terminals	+UG, -UG	DC-bus voltage
		T1, T2	Temperature switches (only 9351 brake module)
		RB1, RB2	Brake resistor (only 9352 brake chopper)
Ⓒ	LED	Green	Voltage is applied to terminals +UG, -UG
		Yellow	Braking unit is in braking operation
Ⓓ	Switches	S1, S2	Setting the switching thresholds of the braking unit
		S3	Setting of the configuration as master or slave for parallel operation
Ⓔ	Synchronisation interface	E1, E2	Inputs
		A1, A2	Outputs

This documentation applies to ...

- ▶ Braking units EMB935x-E. 1x (9351 - 9352)
- ▶ Braking units EMB935x-C. 1x V003 cold plate (9351 - 9352)

	EMB	935x	-	x.	1x
Product range					
		9350 braking unit			
9351 =		brake module			
9352 =		brake chopper			
Design					
C =		cold plate			
E =		built-in unit			
Hardware version					

Application range

The use of the braking units is permissible with devices of the 8200, 9300 and 82Vector product series (15 - 90 kW).

Document history

Material number	Version			Description
13267960	8.0	08/2008	TD34	Extension by chapter 5.5
13228338	7.0	11/2007	TD34	Complete revision
00492694	6.0	06/2004	–	Revision of chapter 4
00454366	5.0	06/2002	–	Change of name
00451254	4.0	02/2002	–	Revision of the chapters 3.3.3 and 4.1.3
00393687	3.0	04/2000	–	Revision of chapter 4.3.2
00393687	2.0	01/1997	–	Revision of chapter 4
00391576	1.0	08/1996	–	First edition, monolingual



Tip!

Current documentation and software updates concerning Lenze products can be found on the Internet in the "Services & Downloads" area under <http://www.Lenze.com>

© 2008 Lenze Drive Systems GmbH, Hans-Lenze-Straße 1, D-31855 Aerzen

No part of this documentation may be reproduced or made accessible to third parties without written consent by Lenze Drive Systems GmbH.

All information given in this documentation has been selected carefully and complies with the hardware and software described. Nevertheless, discrepancies cannot be ruled out. We do not take any responsibility or liability for any damage that may occur. Necessary corrections will be included in subsequent editions.

1	Preface and general information	9
1.1	About these Operating Instructions	9
1.1.1	Terminology used	9
1.2	Legal regulations	10
2	Safety instructions	12
2.1	General safety and application notes for Lenze controllers	12
2.2	General safety and application notes for Lenze braking units	16
2.3	Residual hazards	17
2.4	Definition of notes used	18
3	Technical data	19
3.1	Features	19
3.2	General data and operating conditions	20
3.3	Rated data	21
3.3.1	Braking units	21
3.3.2	Assignment table for brake resistors	22
3.3.3	Fuses and cable cross-sections	22
4	Mechanical installation	23
4.1	Important notes	23
4.2	Mounting with fixing rails (standard installation)	24
4.3	Mounting with thermal separation (push-through technique)	25
4.4	Mounting in cold-plate design	27
4.4.1	Fields of application	27
4.4.2	Requirements with regard to the cooler	27
4.4.3	Thermal behaviour of the complete system	28
4.4.4	Mounting	29
5	Electrical installation	30
5.1	Important notes	30
5.1.1	Protection of persons	30
5.1.2	Device protection	30
5.2	Cable specification	31

5.3	Connection	32
5.3.1	Power connections	32
5.3.2	Permissible cable lengths	32
5.3.3	Fusing	34
5.3.4	Temperature monitoring	34
5.3.5	9351 brake module to controllers 822X and E82Vector (15 - 90 kW)	35
5.3.6	9352 brake chopper to controllers 822X and E82Vector (15 - 90 kW)	36
5.3.7	9351 brake module to 93XX controllers	37
5.3.8	9352 brake chopper to 93XX controllers	38
5.3.9	Setting the switching threshold	39
5.4	Parallel connection	40
5.4.1	Braking units with brake resistor	40
5.4.2	Braking units with a common brake resistor	44
5.5	Use of brake resistors smaller 27R	45
6	Commissioning	46
6.1	Important notes	46
7	Troubleshooting and fault elimination	47
8	Appendix	48
8.1	Accessories	48
8.1.1	Rating for Lenze brake resistors	48
8.2	Glossary	50
8.5	Index	51

1 Preface and general information

1.1 About these Operating Instructions

- ▶ The present Operating Instructions will help you to work safely on and with the 935X braking units. They contain safety instructions that must be followed.
- ▶ All persons working on or with the 935X braking units must have the Operating Instructions available and observe the information and notes relevant for them.
- ▶ The Operating Instructions must always be in a complete and perfectly readable state.

1.1.1 Terminology used

Braking unit

For **9351 brake module** or **9352 brake chopper with brake resistor**, the term **braking unit** is used in the following text.

Controller

For **93XX servo inverter** or **82XX frequency inverter**, the term **controller** is used in the following text.

Drive system

For drive systems with 935X braking units and other Lenze drive components, the term **drive system** is used in the following text.

1 Preface and general information

Legal regulations

1.2 Legal regulations

Labelling

Lenze 935X braking units are clearly labelled by the content of the nameplate.

Manufacturer

Lenze Drive Systems GmbH, Hans-Lenze-Straße 1, D-31855 Aerzen, Germany

CE conformity

Compliant with "Low voltage" EC Directive

Application as directed

935Xbraking units

- ▶ are additional units for the Lenze controllers:
 - 822X frequency inverters (8221 to 8227)
 - 824X frequency inverters (8241 to 8246)
 - 82Vector frequency inverters (15 - 90 kW)
 - 93XX servo inverters (9321 to 9333)
 - Operation with the 820X or 821X frequency inverters is possible.
- ▶ must only be operated under the ambient conditions prescribed in these Operating Instructions.
- ▶ Are components
 - for installation within a machine.
 - for assembly with other components into a machine.
- ▶ are electrical equipment for installation within control cabinets or similar closed electrical operating areas.
- ▶ meet the protection requirements of the "Low voltage" EC Directive.
- ▶ Are not machines in the context of the EC machinery directive.
- ▶ Are not household appliances but are intended solely for utilisation as components for industrial use.

Drive systems with a 935X braking unit

- ▶ The user is responsible for the compliance of the machinery application with the EC directives.

Any other use shall be deemed improper!

Liability

The information, data and notes in these instructions met the state of the art at the time of printing. Claims on modifications referring to braking units that have already been supplied cannot be derived from the information, illustrations and descriptions.

The information on processes and circuits given in these instructions are suggestions. The suitability of these suggestions to the related application must be checked. Lenze does not accept any responsibility for the suitability of the processes and circuit suggestions given.

The information in these instructions describe the features of the products without providing any warranty.

No liability is accepted for damage and failures caused by:

- ▶ Disregarding of these instructions
- ▶ Unauthorised alterations on the braking units
- ▶ Operating errors
- ▶ Improper working on and with the braking units

Warranty

See terms of sales and delivery of Lenze Drive Systems GmbH.

Warranty claims must be made to Lenze immediately after having detected the defect or fault.

The warranty is void in all cases where liability claims cannot be made.

2 Safety instructions

General safety and application notes for Lenze controllers

2 Safety instructions

2.1 General safety and application notes for Lenze controllers

(in accordance with Low-Voltage Directive 2006/95/EC)

For your personal safety

Depending on their degree of protection, some parts of the Lenze controllers (frequency inverters, servo inverters, DC speed controllers) and their accessory components can be live, moving and rotating during operation. Surfaces can be hot.

Non-authorized removal of the required cover, inappropriate use, incorrect installation or operation, creates the risk of severe injury to persons or damage to material assets.

For more information, please see the documentation.

High amounts of energy are produced in the controller. Therefore it is required to wear personal protective equipment (body protection, headgear, eye protection, ear protection, hand guard).

All operations concerning transport, installation, and commissioning as well as maintenance must be carried out by qualified, skilled personnel (IEC 364 or CENELEC HD 384 or DIN VDE 0100 and IEC report 664 or DIN VDE 0110 and national regulations for the prevention of accidents must be observed).

According to this basic safety information, qualified, skilled personnel are persons who are familiar with the assembly, installation, commissioning, and operation of the product and who have the qualifications necessary for their occupation.

Application as directed

Controllers are components which are designed for installation in electrical systems or machines. They are not to be used as domestic appliances, but only for industrial purposes according to EN 61000-3-2.

When controllers are installed into machines, commissioning (i.e. starting of the operation as directed) is prohibited until it is proven that the machine complies with the regulations of the EC Directive 98/37/EC (Machinery Directive); EN 60204 must be observed.

Commissioning (i.e. starting of the operation as directed) is only allowed when there is compliance with the EMC Directive (2004/108/EC).

The controllers meet the requirements of the Low-Voltage Directive 2006/95/EC. The harmonised standard EN 61800-5-1 applies to the controllers.

The technical data and supply conditions can be obtained from the nameplate and the documentation. They must be strictly observed.

Warning: Controllers are products which can be installed in drive systems of category C2 according to EN 61800-3. These products can cause radio interferences in residential areas. In this case, special measures can be necessary.

Transport, storage

Please observe the notes on transport, storage, and appropriate handling.

Observe the climatic conditions according to the technical data.

Installation

The controllers must be installed and cooled according to the instructions given in the corresponding documentation.

Ensure proper handling and avoid excessive mechanical stress. Do not bend any components and do not change any insulation distances during transport or handling. Do not touch any electronic components and contacts.

Controllers contain electrostatic sensitive devices which can easily be damaged by inappropriate handling.

Do not damage or destroy any electrical components since this might endanger your health!

Electrical connection

When working on live controllers, observe the applicable national regulations for the prevention of accidents (e.g. VBG 4).

The electrical installation must be carried out according to the appropriate regulations (e.g. cable cross-sections, fuses, PE connection). Additional information can be obtained from the documentation.

This documentation contains information on installation in compliance with EMC (shielding, earthing, filters, and cables). These notes must also be observed for CE-marked controllers. The manufacturer of the system is responsible for compliance with the limit values demanded by EMC legislation. The controllers must be installed in housings (e.g. control cabinets) to meet the limit values for radio interferences valid at the site of installation. The housings must enable an EMC-compliant installation. Observe in particular that e.g. the control cabinet doors have a circumferential metal connection to the housing. Reduce housing openings and cutouts to a minimum.

Lenze controllers can cause a direct current in the protective conductor. If a residual current device (RCD) is used as a protective means in case of direct or indirect contact, only a residual current device (RCD) of type B may be used on the current supply side of the controller. Otherwise, another protective measure such as separation from the environment through double or reinforced insulation or disconnection from the mains by means of a transformer must be applied.

Operation

If necessary, systems including controllers must be equipped with additional monitoring and protection devices according to the valid safety regulations (e.g. law on technical equipment, regulations for the prevention of accidents). The controllers can be adapted to your application. Please observe the corresponding information given in the documentation.

After the controller has been disconnected from the supply voltage, all live components and power connections must not be touched immediately because capacitors can still be charged. Please observe the corresponding stickers on the controller.

All protection covers and doors must be shut during operation.

Notes for UL-approved systems with integrated controllers: UL warnings are notes that only apply to UL systems. The documentation contains special UL notes.

Safety functions

Special controller variants support safety functions (e.g. "safe torque off", formerly "safe standstill") according to the requirements of Appendix I No. 1.2.7 of the EC Directive "Machinery" 98/37/EC, EN 954-1 Category 3 and EN 1037. Strictly observe the notes on the safety functions given in the documentation for the respective variants.

Maintenance and servicing

The controllers do not require any maintenance if the prescribed operating conditions are observed.

If the ambient air is polluted, the cooling surfaces of the controller may become dirty or the air vents may be obstructed. Therefore, clean the cooling surfaces and air vents periodically under these operating conditions. Do not use sharp or pointed tools for this purpose!

Disposal

Recycle metal and plastic materials. Ensure professional disposal of assembled PCBs.

The product-specific safety and application notes given in these instructions must be observed!

2.2 General safety and application notes for Lenze braking units

- ▶ These safety notes do not claim to be complete. If any questions or problems occur, please contact the responsible Lenze representative.
- ▶ The braking unit meets the state of the art at the time of delivery and is generally safe to operate.
- ▶ The information in these Operating Instructions refer to the specified versions of the braking units.
- ▶ The braking unit is hazardous to persons, to the braking unit itself, and to other properties of the operator if
 - non-qualified personnel work on and with the braking unit.
 - the braking unit is used improperly.
- ▶ The procedural notes and circuit details represented within these Operating Instructions are recommendations, the transferability of which to the corresponding application has to be checked.
- ▶ The braking units must be planned in such a way that if they are installed correctly and used for their designed purpose in fault-free operation, they fulfil their function and do not put any persons at risk. This also applies to the interaction of the braking units with the system as a whole.
- ▶ Take additional measures in order to narrow down consequences due to faults, which can cause danger to persons or damage to material assets:
 - Further independent equipment taking over the function of the braking unit
 - Electrical or non-electrical protective devices (locking or mechanical locks) for the drive system
 - Measures concerning the system as a whole
- ▶ Do not operate the braking unit unless it is in perfect condition.
- ▶ Changes or modifications of the braking unit are strictly prohibited. In any case, consultation with Lenze is required.

2.3 Residual hazards

Protection of persons

- ▶ Before carrying out operations on the braking unit, check whether all power terminals are in a deenergised state:
 - After power-off the power terminals $+U_G$, $-U_G$ and RB1 and RB2 still carry dangerous voltage for at least 3 minutes.
- ▶ S1, S2 and S3 have a mains potential!
 - Wait for at least 3 minutes before changing over the switches.

2 Safety instructions

Definition of notes used



2.4 Definition of notes used

The following pictographs and signal words are used in this documentation to indicate dangers and important information:



Safety instructions

Structure of safety instructions:

	Danger! (characterises the type and severity of danger) Note (describes the danger and gives information about how to prevent dangerous situations)
---	--

Pictograph and signal word	Meaning
 Danger!	Danger of personal injury through dangerous electrical voltage. Reference to an imminent danger that may result in death or serious personal injury if the corresponding measures are not taken.
 Danger!	Danger of personal injury through a general source of danger. Reference to an imminent danger that may result in death or serious personal injury if the corresponding measures are not taken.
 Stop!	Danger of property damage. Reference to a possible danger that may result in property damage if the corresponding measures are not taken.

Application notes

Pictograph and signal word	Meaning
 Note!	Important note to ensure troublefree operation
 Tip!	Useful tip for simple handling
	Reference to another documentation

3 Technical data

3.1 Features

- ▶ Two designs with identical dimensions
 - 9351 brake module with internal brake resistor for frequent braking with low power or unfrequent braking with medium power
 - 9352 brake chopper with external brake resistor for higher peak braking power and continuous braking power
- ▶ Conversion of the mechanical braking energy into heat energy
 - During braking operation, the controller does not set pulse inhibit unintentionally, i.e. braking operation remains controlled
- ▶ Very short braking times can be reached
- ▶ Enclosure IP20 for installation within the control cabinet
- ▶ DIN rail mounting
- ▶ Separable heatsink
 - Cooling outside of the control cabinet can be realised
- ▶ Switching threshold for the mains voltages 230 V, 400...460 V and 480 V can be set via internal switches
- ▶ Parallel operation of several braking units possible
 - Synchronisation via built-in interface
- ▶ Status display via LEDs
- ▶ Braking units are not short-circuit-proof

3.2 General data and operating conditions

General data

Conformity and approval		
Conformity		
CE	2006/95/EC	Low-Voltage Directive
Approval		
UL	UL 508C	Power Conversion Equipment for USA and Canada 1D74, file No. E132659

Protection of persons and equipment		
Enclosure	EN 60529	IP10 IP20 with mounted terminal covers IP41 on the heatsink side for thermally separated mounting (push-through technique).
	NEMA 250	Protection against contact according to type 1
Insulation resistance	EN 61800-5-1	Site altitude < 2000 m: Overvoltage category III
		Site altitude > 2000 m: Overvoltage category II

Operating conditions

Ambient conditions		
Climatic		
Storage	IEC/EN 60721-3-1	1K3 (-25 ... +70 °C)
Transport	IEC/EN 60721-3-2	2K3 (-25 ... +60 °C)
Operation	IEC/EN 60721-3-3	3K3 (0 ... +40 °C) without power reduction
		3K3 (+40 ... +50 °C) with power reduction by 2.5%/ °C
Pollution	EN 61800-5-1	Degree of pollution 2
Site altitude h		h ≤ 1000 m amsl without power reduction
		1000 m amsl < h < 4000 m amsl with power reduction by 5%/ 1000 m
Mechanical		
Vibration resistance	EN 50178 EN 61800-5-1 Germanischer Lloyd, general conditions	Acceleration resistant up to 0.7 g

3.3 Rated data

3.3.1 Braking units

Type of braking unit			EMB9351	EMB9352
Supply voltage U_N		U_{DC} [V]	270 V - 0 % ... 775 V + 0 %	
Switching threshold U_Z ¹⁾		U_{DC} [V]	375, 725, 765	
Peak current for 1.33 s On; 1.67 s Off		I_{DC} [A]	16	32
Max.continuous current		I_{DC} [A]		14 (arithm. mean value) 20 (r.m.s. value)
Peak braking power P_{Bmax} for U_Z	DC 375 V	P_{DC} [kW]	3	12
	DC 725 V	P_{DC} [kW]	11	23
	DC 765 V	P_{DC} [kW]	12	25
Continuous braking power P_{Bd} for U_Z (related to the arithm. mean value)	DC 375 V	P_{DC} [kW]	0.1	5
	DC 725 V	P_{DC} [kW]	0.1	10
	DC 765 V	P_{DC} [kW]	0.1	11
Smallest brake resistance R_{Bmin}	DC 375 V	R [Ω]	47 internal	$12 \pm 10\%$
	DC 725 V	R [Ω]	47 internal	$27 \pm 10\%$ ²⁾
	DC 765 V	R [Ω]	47 internal	$27 \pm 10\%$ ²⁾
Maximum energy W_B		W [kWs]	50 (4s On; 500s Off)	(external resistor)
Mass		[kg]	2.6	2.2

¹⁾ Adjustable (see chapter 5.3.9)

²⁾ Operation of 2 parallel braking units (master/slave) at 18 Ω possible. Observe the power of the resistor (see chapter 5.4.2).
Further information on the selection of the brake resistors or regarding the use of brake resistors < 27 Ω (see chapter 5.5).

3 Technical data

Rated data

Assignment table for brake resistors

3.3.2 Assignment table for brake resistors

The assignment is carried out on the basis of the motor power and applies up to the limit value specified.

Motor power	Type ¹⁾	R	Peak braking power	Rated power	Thermal capacity
[kW]		[Ω]	[kW]	[kW]	[kWs]
< 2.6	ERBD180R300W	180	3.0	0.3	45
< 5.2	ERBD082R600W	82	6.0	0.6	90
< 7.4	ERBD068R800W	68	8.0	0.8	120
< 11	ERBD047R01K2	47	12	1.2	180
< 13.2	ERBD033R02K0	33	17	2.0	300
< 20.3	ERBD022R03K0	22	26	3.0	450
< 30	ERBD018R03K0	18	32.5	3.0	450

¹⁾ Recommended Lenze brake resistor for $U_z = 765 \text{ V}$ or $U_z = 725 \text{ V}$

The resistors are designed for a cycle of:

- ▶ max. 15 s of braking with peak braking power
- ▶ at least 150 s recovery time after braking

3.3.3 Fuses and cable cross-sections

Type	Fuses		Cable cross-section	
	VDE	UL	mm ²	AWG
9351	20 A	20 A K5	2.5	12
9352	50 A	40 A K5	6 ¹⁾	10

¹⁾ Use terminal pins if a flexible cable is used

4 Mechanical installation

4.1 Important notes

- ▶ Only use the braking units as built-in units!
- ▶ Observe mounting clearances!
 - Observe clearance of 100 mm at the top and at the bottom.
- ▶ Make sure that the cooling air can access and the exhaust air can escape unimpededly.
- ▶ If the cooling air is polluted (dust, lint, greases, aggressive gases), which may affect the function of the braking units:
 - Take adequate countermeasures, e. g. separate air guide, installation of filter, regular cleaning, etc.
- ▶ Do not exceed the permissible range of the ambient operating temperature (see chapter).
- ▶ If the braking units are permanently exposed to vibrations or shocks:
 - Check the use of vibration dampers.



Danger!

- ▶ In case of fault, brake resistors can reach very high temperatures; the brake resistor may even burn down, e. g. in the case of
 - mains overvoltage,
 - application-specific overload,
 - internal error.
- ▶ Therefore mount the brake resistors so that no damage can be caused by the possible, very high temperatures.

Possible mounting positions

- ▶ Vertically on the rear panel of the control cabinet, power connections facing upwards
 - Fixed with enclosed fixing rails (see chapter 4.2)
 - Thermally separated with an external heatsink ("Push-through technique") (see chapter 4.3)
 - Thermally separated with an external convection cooler ("Cold plate" technology) (see chapter 4.4)

4.2 Mounting with fixing rails (standard installation)

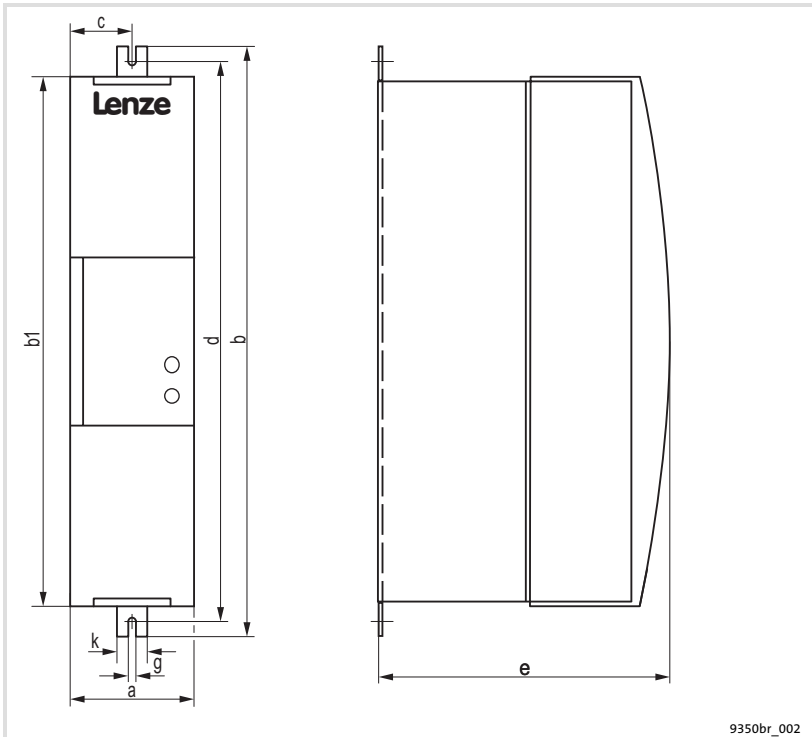

Fig. 1 Dimensions

Type	a	b	b1	c	d	e	g	k
	[mm]	[mm]	[mm]	[mm]	[mm]	[mm]	[mm]	[mm]
9351 / 9352	52	384	350	26	365	186	6.5	30

4.3 Mounting with thermal separation (push-through technique)

You can mount the heatsink of the braking units outside of the control cabinet to reduce the heat generation within the control cabinet. You require a mounting frame with a seal (see accessories).

- ▶ Distribution of the power loss:
 - Approx. 65% via separate cooler
 - Approx. 35% in the interior of the braking unit
- ▶ The class of protection of the separated cooler is IP41.
- ▶ Furthermore the rated data of the braking unit apply.

Mounting preparation

1. Insert the halves of the mounting frame into the location groove on the braking unit, which is provided for this purpose.
2. Push the frame halves together until the ends lock into place.
3. Slip the seal over the heatsink of the braking unit and insert it into the location hole provided.

4 Mechanical installation

Mounting with thermal separation (push-through technique)

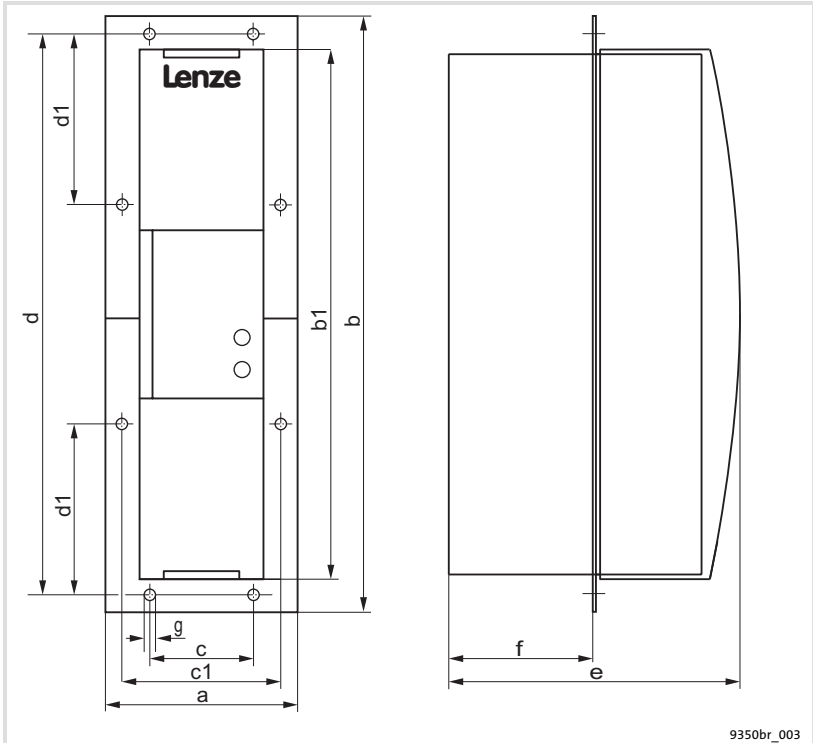

Fig. 2 Dimensions

Type	a	b	b1	c	c1	d	d1	e	f	g
	[mm]	[mm]	[mm]	[mm]	[mm]	[mm]	[mm]	[mm]	[mm]	[mm]
9351 / 9352	86.5	386	350	34	69.5	367	162.5	186	92	6.5

Mounting cutout Z

Type	Height	Width
	[mm]	[mm]
9351 / 9352	350 ± 3	56 ± 3

4.4 Mounting in cold-plate design

4.4.1 Fields of application

This variant is especially used in the following applications.

- ▶ Use of cooling units without blower:
 - Heavy pollution of the cooling air, for instance, impedes the operation of blowers, as it would affect both the function and the service life of the fans.
- ▶ High degree of protection in the case of thermal separation:
 - If thermal separation has to be used due to the power balance within the control cabinet, and if the enclosure of the cooling unit has to be greater than IP41.
- ▶ Use of the controllers directly within the machine with a reduced overall depth:
 - Constructional elements of the machine take over the cooler function
- ▶ Collective coolers (water coolers, forced-air coolers, etc.) for all controllers are provided for in the system concept.

4.4.2 Requirements with regard to the cooler

The dissipation of the power loss by the braking unit can be effected via coolers operating with different cooling media (air, water, oil, etc.).

In addition to the characteristics specified by the user, the following is important for a safe operation:

- ▶ Good thermal connection to the cooler
 - The contact surface between the external cooler and the cooling plate of the braking unit at least has to be as large as the cooling plate.
 - Surface planarity of the contact surface approx. 0.05 mm.
 - Connect cooler and cooling plate with all screwed connections specified.
- ▶ Observe thermal resistance $R_{thmin\ heatsink}$ (transition of cooler - cooling medium) according to table. The values apply to
 - The operation of the braking unit under rated operating conditions (see chapter 3.3)
 - A maximum temperature of the cooling plate of 75 °C, measuring point: narrow side of the cooling plate level with a point half way up the controller.

4 Mechanical installation

Mounting in cold-plate design

Thermal behaviour of the complete system

Braking unit	Cooling path	
	Power to be dissipated P_{VAR} [W]	R_{thmin} heatsink [K/W]
9351-V003	100	0.3
9352-V003	63	0.3

4.4.3 Thermal behaviour of the complete system

The thermal conditions within a system are affected by some basic conditions. The following items have to be taken into consideration when a control cabinet or system is designed:

Ambient temperature of the controllers

For the ambient temperature of the braking unit, furthermore the rated data and the corresponding derating factors at increased temperature apply.

Heat generation in the interior of control cabinets

In addition to the device losses that are dissipated via the heatsink, further losses have to be taken into consideration for the design:

- ▶ Losses within the braking unit
 - These losses are caused by the electronic supply, fans, DC-bus capacitors, etc.
- ▶ Losses of the components on the mains and motor side
- ▶ Radiation of heat from the external cooling unit into the interior
 - This portion of the heat energy for instance depends on the type of cooling unit and the mounting mode.

Heat distribution on the collective cooler / within the control cabinet

If you mount several components (controllers, braking units, etc.) onto a common cooler, it has to be ensured that the temperature on the cooling plate of each individual component does not exceed 75 °C.

Measures:

- ▶ Observe minimum clearances around the convection cooler.
- ▶ Do not mount the components on top of each other.
- ▶ In order to avoid heat concentrations within the control cabinet, use internal fans, if required.

4.4.4 Mounting

Before screwing the cooler and the cooling plate of the braking unit together, apply the heat conducting paste supplied, in order to keep the heat transfer resistance as low as possible.

- ▶ Clean the contact surface using spirit.
- ▶ Apply the heat conducting paste in a thin layer using a spatula or a paint brush.
 - The heat conducting paste in the accessory kit is sufficient to cover a surface of approx. 1000 cm².
- ▶ Mount controller to the heatsink with 4 M5 fixing screws.
 - Screw-tightening torque: 3.4 Nm.

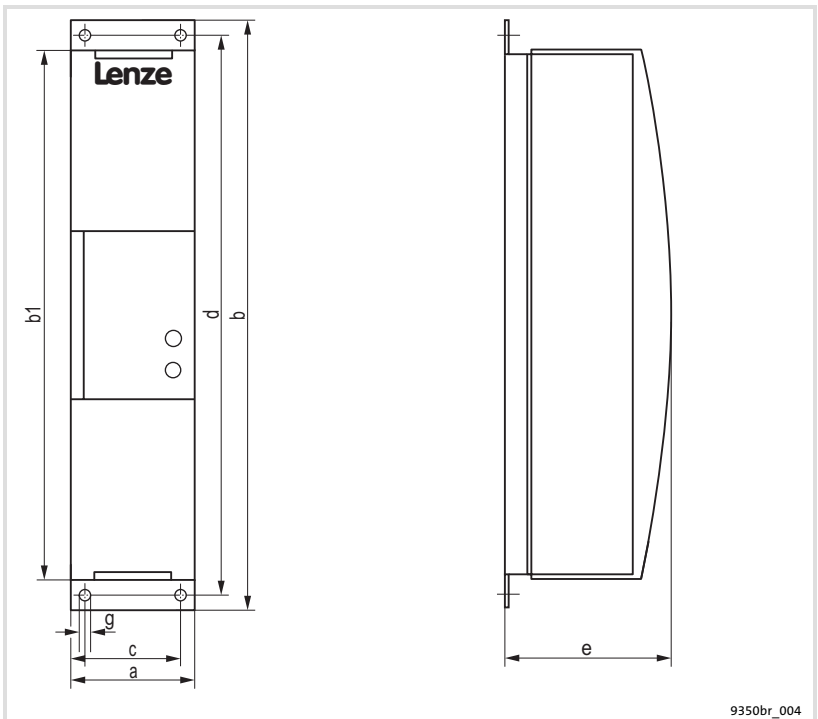

Fig. 3 Dimensions

Type	a	b	b1	c	d	e	g
	[mm]	[mm]	[mm]	[mm]	[mm]	[mm]	[mm]
9351-V003	52	381	350	34	367	104	6.5
9352-V003							

5 Electrical installation

Important notes
Protection of persons

5 Electrical installation

5.1 Important notes



Stop!

The drive controller contains electrostatically sensitive components. The personnel must be free of electrostatic charge when carrying out assembly and service operations.

5.1.1 Protection of persons



Danger!

Before carrying out operations on the controller, check whether all power terminals are in a deenergised state:

- ▶ After power-off the power terminals $+U_G$, $-U_G$ and RB1, RB2 still carry dangerous voltages for 3 minutes.
- ▶ S1, S2 and S3 have a mains potential!
 - Wait for at least 3 minutes before changing over the switches.
- ▶ During braking operation the DC-bus voltage is still applied after power-off:
 - In order to avoid that energy is fed into the DC bus further on, controller inhibit has to be set for all controllers in the interconnection.
 - Observe that the drive system coasts down after controller inhibit has been set.

Replacing defective fuses

Replace defective fuses only in the deenergised state with the type specified.

5.1.2 Device protection

In the case of condensation, only connect the controllers to the mains voltage if the humidity has evaporated again.

5.2 Cable specification

- ▶ The cables used have to comply with the requirements on the location (e. g. EN 60204-1).
- ▶ The corresponding minimum cross-sections of the cables have to be observed.
- ▶ Only use shielded cables with a braid of tinned or nickel-plated copper. Shields of steel braid are unsuitable.
 - The overlap rate of the braid has to be at least 70 % with an overlap angle of 90 °.

5 Electrical installation

Connection Power connections

5.3 Connection

Preparation

- ▶ Remove cover of the power connections.
- ▶ Remove cover of the control connections.

5.3.1 Power connections

- ▶ The data regarding cable cross-sections and fuses are recommendations and refer to the use:
 - In control cabinets and machines
 - Installation in the cable duct
 - Maximum ambient temperature +40 °C
- ▶ The cables between the braking unit and the controller may not exceed a length of 2 m.
 - For cable lengths ≤ 0.5 m you can use unshielded single cores.
- ▶ If an interference suppression of the drive system (limit class A or B in accordance with DIN 55011) is required, the cables have to be shielded
 - Always apply the shield on both sides.
- ▶ It is the user's responsibility to take further standards (e. g.: VDE 0113, VDE 0289, etc.) into consideration.

5.3.2 Permissible cable lengths

To operate the 9350 braking units in a trouble-free manner, observe the following installation instructions:

Cable	9351 brake module	9352 brake chopper
	[m]	[m]
Controller - 935X (low-inductance cables, i. e. conduct in a bunched manner)	2	2
935X - external brake resistor	(internal brake resistor)	8
Synchronisation cable between 935X (only for parallel operation)	2	2

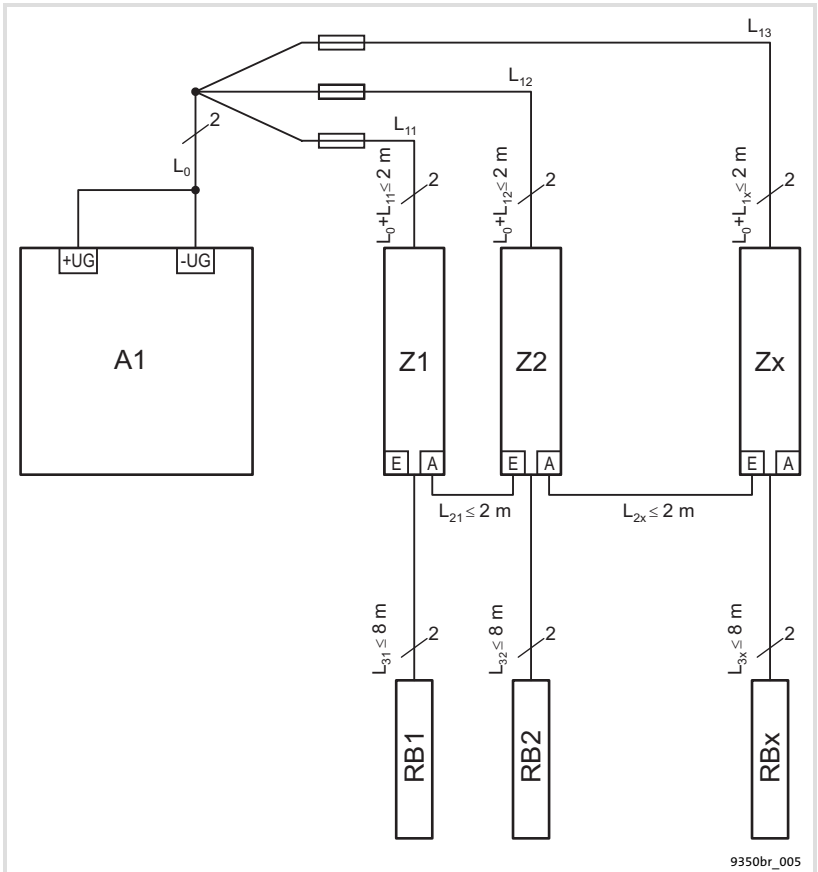

Fig. 4 Example circuit for parallel operation

A1	Controller
Z1	Brake chopper 1 = master
Z2 ... Zx	Brake chopper 2 ... x = slave 2 ... slave x
RB1, RB2, RBx	External brake resistors
L0	Cable length of controller — collection point
L1x	Cable length of collection point — braking unit
L2x	Cable length of synchronisation cable for parallel operation
L3x	Cable length of brake chopper — brake resistor

5 Electrical installation

Connection Fusing

5.3.3 Fusing

- ▶ Fuses in UL-conform systems have to be UL-approved.
- ▶ The rated voltages of the fuses have to be dimensioned according to the DC-bus voltage.
- ▶ The use of DC-bus fuses is a recommendation.
 - If DC-bus fuses are used, they have to comply with the specifications in chapter 3.3.3.
- ▶ It is the user's responsibility to take further standards (e. g.: VDE 0113, VDE 0289, etc.) into consideration.

Connection

- ▶ Connect cables for the power supply module (934X), controller (93XX) and further braking units (935X) in the DC-bus connection to the screw terminals +UG, -UG on the top at the braking unit and the controller.
- ▶ Observe the screw-tightening torques:

Terminals	Tightening torques	
	[NM]	[lb-in]
+UG, -UG	0.5 ... 0.6	4.4 ... 5.3
PE	1.7	15

For shielded cables:

- ▶ Apply the shield correctly (required parts in the accessory kit):
 - Screw shield sheet onto the fixing bracket.
 - Clamp the shield with clips. Do not use as strain relief!
 - The PE connection is effected via the fixing bracket.

5.3.4 Temperature monitoring



Stop!

- ▶ Always connect the temperature monitoring.
 - The temperature monitoring is required for the safe disconnection in the case of fault.

Loop the temperature switches of the external brake resistors or the 9351 brake module in the monitoring circuit, so that the following reactions are triggered if the temperature monitoring responds:

- ▶ All controllers which are connected to the braking units are disconnected from the mains.
- ▶ Controller inhibit is set for those controllers.

5.3.5 9351 brake module to controllers 822X and E82Vector (15 - 90 kW)

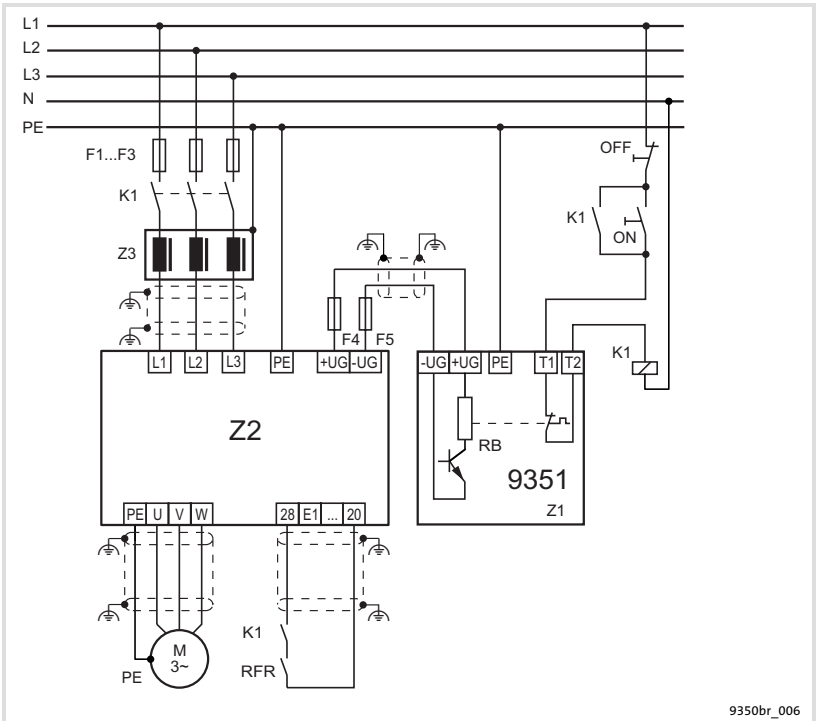

Fig. 5 Connection of the 9351 brake module to controllers 822X and E82Vector (15 - 90 kW)

- Z1 Brake module
- Z2 Controller
- Z3 Mains choke
- K1 Mains contactor
- F1 ... F3 Mains fuses
- F4, F5 DC-bus fuses (recommendation)

	Default setting		
Mains voltage [V_{eff}]	230	400 ... 460	480
Switching threshold [V]	375	725	765
Switch position S1	OFF	ON	ON
Switch position S2	OFF	OFF	ON

5 Electrical installation

Connection

9352 brake chopper to controllers 822X and E82Vector (15 - 90 kW)

5.3.6 9352 brake chopper to controllers 822X and E82Vector (15 - 90 kW)

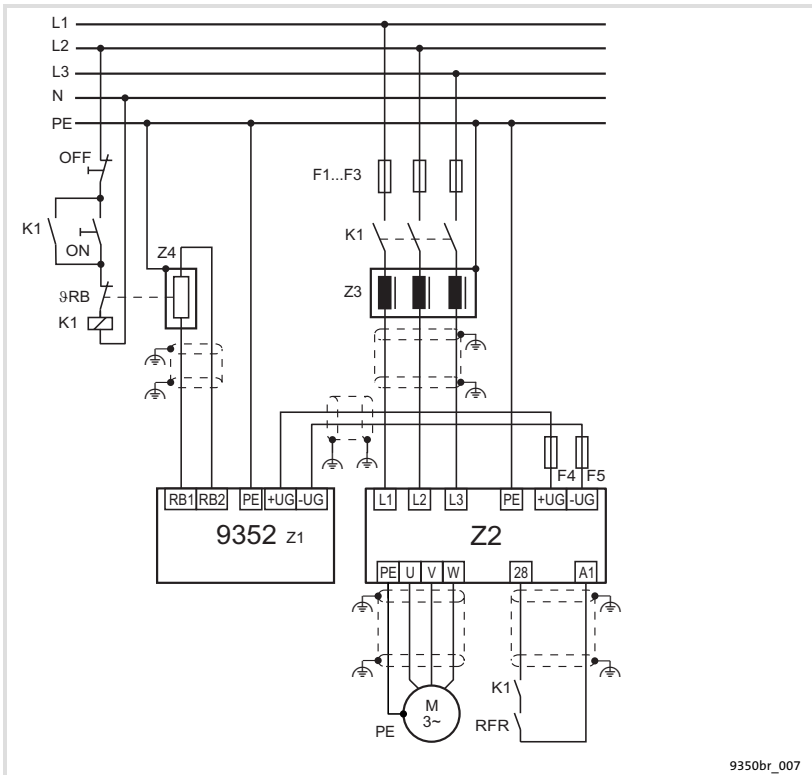
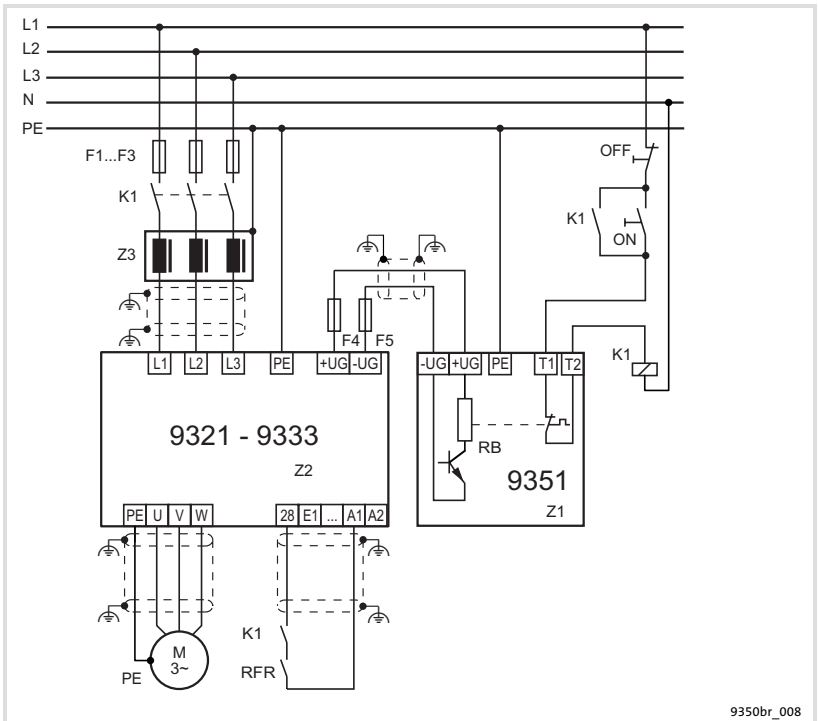

Fig. 6 Connection of the 9352 brake chopper to controllers 822X and E82Vector (15 - 90 kW)

Z1	Brake chopper
Z2	Controller
Z3	Mains choke
Z4	Brake resistor
K1	Mains contactor
F1 ... F3	Mains fuses
F4, F5	DC-bus fuses (recommendation)

			Default setting
Mains voltage [V_{eff}]	230	400 ... 460	480
Switching threshold [V]	375	725	765
Switch position S1	OFF	ON	ON
Switch position S2	OFF	OFF	ON

5.3.7 9351 brake module to 93XX controllers



9350br_008

Fig. 7 Connection of the 9351 brake module to 93XX controllers

- Z1 Brake module
- Z2 Controller
- Z3 Mains choke
- K1 Mains contactor
- F1 ... F3 Mains fuses
- F4, F5 DC-bus fuses (recommendation)

	Default setting		
Mains voltage [V _{eff}]	230	400 ... 460	480
Switching threshold [V]	375	725	765
Switch position S1	OFF	ON	ON
Switch position S2	OFF	OFF	ON

5.3.8 9352 brake chopper to 93XX controllers

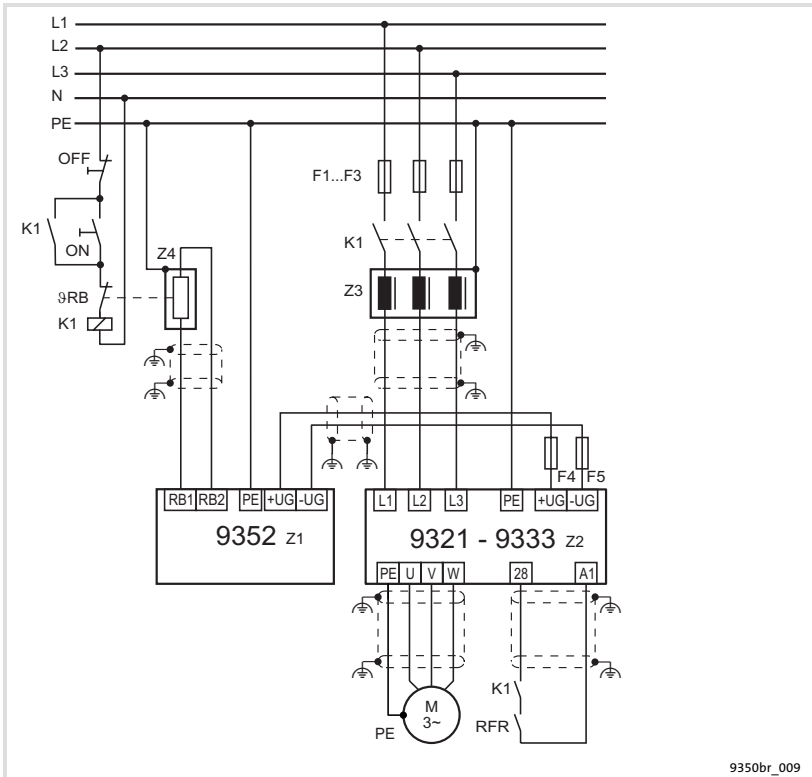

Fig. 8 Connection of the 9352 brake chopper to 93XX controllers

Z1	Brake chopper
Z2	Controller
Z3	Mains choke
Z4	Brake resistor
K1	Mains contactor
F1 ... F3	Mains fuses
F4, F5	DC-bus fuses (recommendation)

			Default setting
Mains voltage [V_{eff}]	230	400 ... 460	480
Switching threshold [V]	375	725	765
Switch position S1	OFF	ON	ON
Switch position S2	OFF	OFF	ON

5.3.9 Setting the switching threshold



Danger!

- ▶ S1, S2 and S3 have a mains potential!
 - Wait for at least 3 minutes before changing over the switches.

Important notes

The switching threshold of the braking unit is the voltage value in the DC bus, at which the brake resistor is connected.

- ▶ The switching threshold depends on the mains voltage.
 - With the switches S1 and S2 you can adapt the switching threshold to the corresponding mains voltage of the controller.
- ▶ For all braking units connected in parallel in the DC-bus connection the same switching threshold has to be set.

Setting

1. Switch the controller to a deenergised state and wait for 3 minutes until the capacitors of the voltage DC-bus are discharged.
2. Remove terminal cover of the control terminals (at the bottom) from the braking unit.
3. Set switches S1 and S2 according to the following table:

			Default setting
Mains voltage [V_{eff}]	230	400 ... 460	480
Switching threshold [V]	375	725	765
Switch position S1	OFF	ON	ON
Switch position S2	OFF	OFF	ON

4. Press terminal cover onto the braking unit again until it snaps into place.

5.4 Parallel connection**Danger!**

- ▶ S1, S2 and S3 have a mains potential!
 - Wait for at least 3 minutes before changing over the switches.

5.4.1 Braking units with brake resistor

You can connect the 935X braking units in parallel in any combination if an individual braking unit cannot completely convert the arising braking power.

Important notes

- ▶ Connect each braking unit in parallel to the terminals +U_G and -U_G of the controllers.
 - For total lengths ≤ 0.5 m a shielding is not required.
- ▶ Connect a brake resistor to each 9352 brake chopper at the terminals RB1 and RB2.
- ▶ Connect the contacts (NC contacts) of the brake resistor temperature monitorings in series.
- ▶ Make sure that the minimum resistance specified in the technical data of the braking units is observed - also in the case of parallel connection of brake resistors (see chapter 3.3).
- ▶ Wire brake resistors connected in parallel so that a simultaneous connection and disconnection is ensured. Otherwise the braking power is not divided equally to the brake resistors connected.



Stop!

Correct synchronisation of braking units connected in parallel:

- ▶ Set switching thresholds of all braking units to the same value (see chapter 5.3.9).
- ▶ Connect synchronisation interfaces correctly
 - Output: A1, A2 / input E1, E2
 - For total lengths ≤ 0.5 m you do not have to use shields.
- ▶ Configuring braking units with switch S3 as master and slave:
 - Configure the first braking unit in the interconnection as master (S3 = OFF).
 - Configure each further braking unit within the interconnection as slave (S3 = ON).

Electrical installation

Parallel connection
Braking units with brake resistor

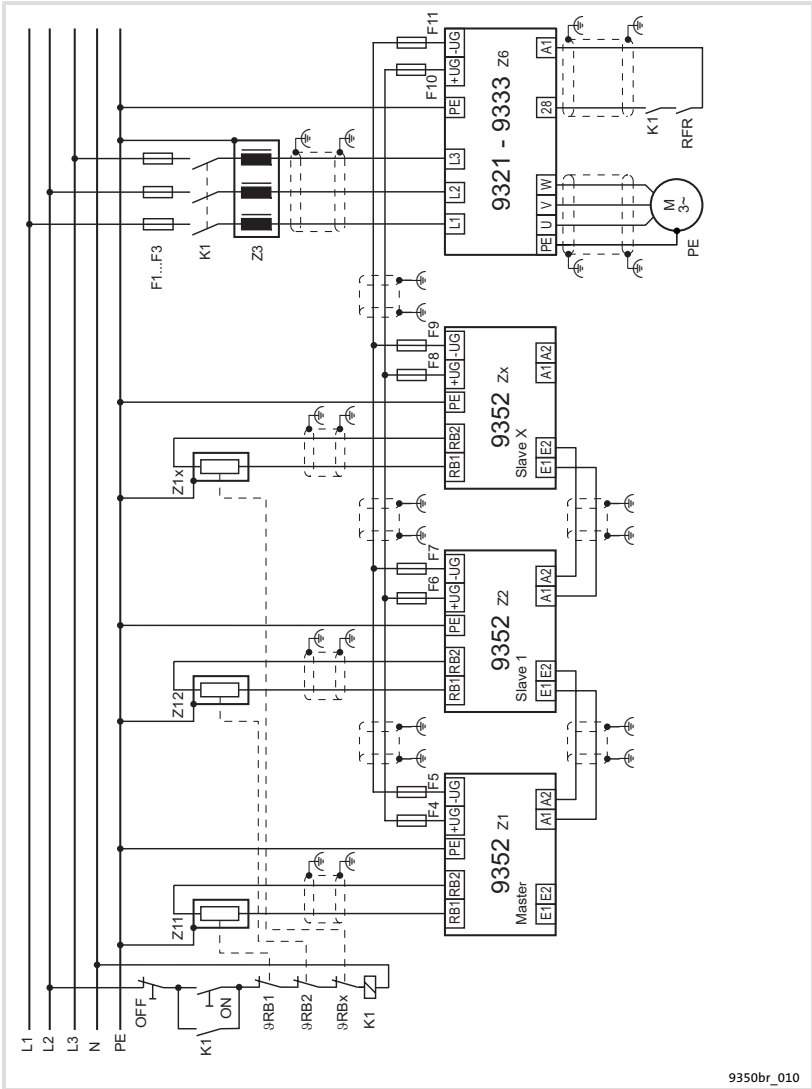

Fig. 9 Parallel connection of 9352 brake choppers

9350br_010

Z1	Brake chopper 1 = master (S3 = OFF)
Z2	Brake chopper 2 = slave (S3 = ON)
Zx	Brake chopper x = slave (S3 = ON)
Z3	Mains choke
Z6	Controller
Z11, Z12, Z1x	External brake resistors
K1	Mains contactor
F1 ... F3	Mains fuses
F4 ... F11	DC-bus fuses (recommendation)



Danger!

The outputs of the synchronisation interfaces have mains potential.

- Only use suitable, insulated cables for wiring.

5 Electrical installation

Parallel connection

Braking units with a common brake resistor

5.4.2 Braking units with a common brake resistor

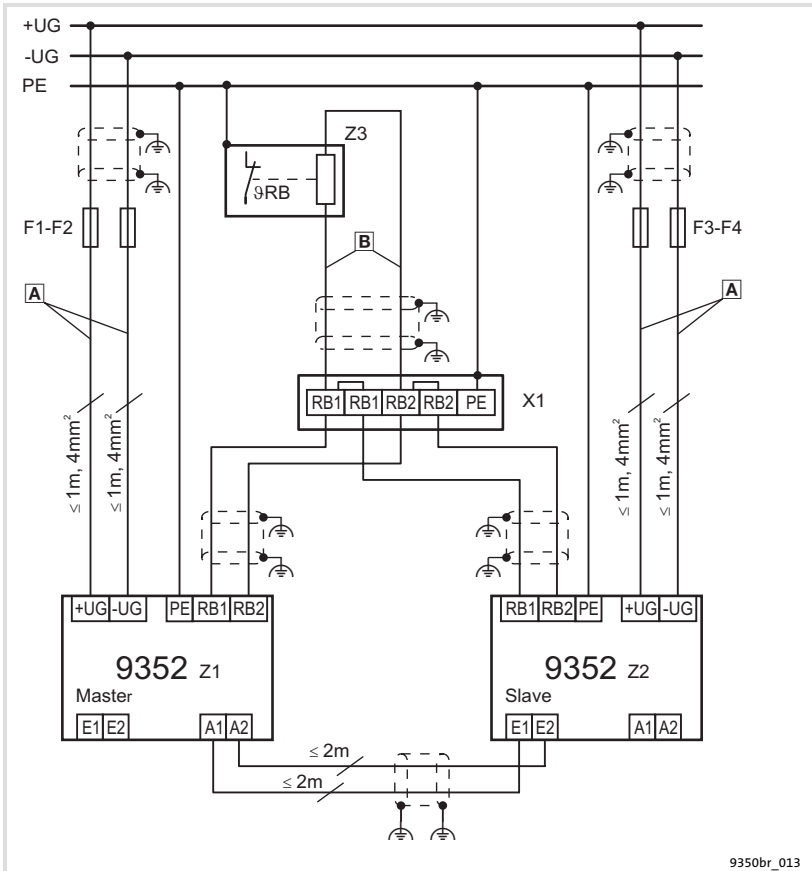

Fig. 10 Parallel operation of 2 brake choppers on one brake resistor

- Z1 Brake chopper 1 = master
- Z2 Brake chopper 2 = slave
- Z3 Brake resistor
- F1 ... F4 DC-bus fuses 25 A
- X1 Terminal strip
- ⊗RB Thermal contact has to be integrated into the temperature monitoring
- Ⓐ Length difference of the 4 cables: $\leq 0.05\text{ m}$
- Ⓑ Cable length of braking unit - brake resistor: $\leq 8\text{ m}$

5.5 Use of brake resistors smaller 27R



Stop!

Failure of the brake chopper if the braking times are exceeded:

- ▶ Observe the power of the brake resistor.
- ▶ Integrate the temperature monitoring of the brake resistor into the emergency stop chain.

When using the external brake resistors with the EMB 9352 brake chopper, the maximum braking times are to be observed.

They result from $t_{on} + t_{off} = 3$ s.

The diagram applies to applications with $U_{mains} \geq 400$ V.

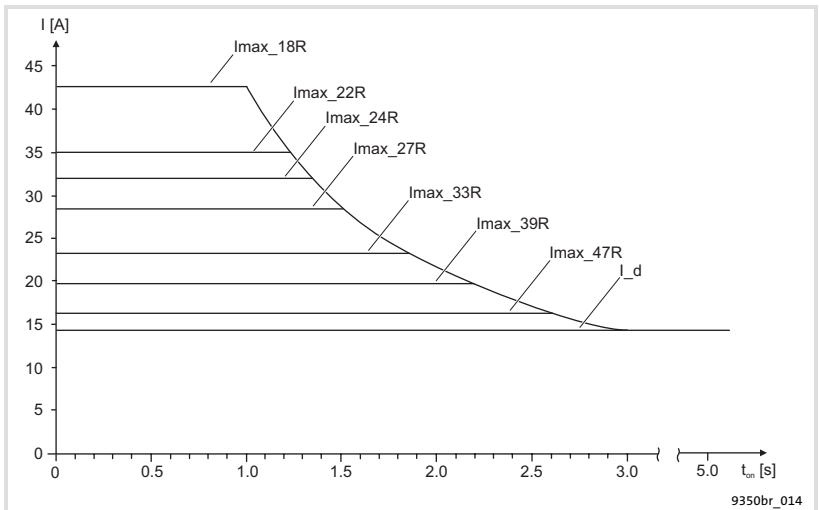

Fig. 11 Braking current of the EMB 9352 brake chopper

I_d Continuous current
 t_{on} Running time

Example for the determination of the braking times with $R_B = 33 \Omega$:

$t_{on} = 1.83$ s; $t_{off} = 1.17$ s.

6 Commissioning

6.1 Important notes



Stop!

Before initial switch-on, check

- ▶ whether the terminals $+U_G$ and $-U_G$ are connected correctly.
 - If $+U_G$ and $-U_G$ are inverted, braking units and all components connected can be destroyed.
- ▶ the switching thresholds of the braking unit(s) are set to the same values for the entire drive system via switches S1 and S2
 - Setting the switching thresholds: see chapter 5.3.9.
- ▶ the braking units are configured correctly via S3 if braking units are connected in parallel.
 - The 1. braking unit as master (S3 = OFF).
 - All further braking units as slaves (S3 = ON).

Operating status display

The two LEDs on the braking unit display the operating status:

LED display		Operating status
Green	Yellow	
Off	Off	Braking unit without voltage, not ready for operation.
On	Off	Braking unit is supplied with voltage and is ready for operation.
On	On	Braking unit in braking operation, energy is converted within the brake resistor. If the braking power is small, the braking times are short, or, during operation with a switching threshold of 375 V, the luminosity of the yellow LED is very low.

Operating notes



Note!

The total braking time of a drive is increased if the power that is regenerated is greater than the peak braking power of the brake resistor assigned.

In this case the controller sets pulse inhibit and reports "overvoltage". Remedy to ensure continuous deceleration with a steady braking torque:

- ▶ Increase deceleration time T_{if} or the QSP ramp at the controller, or
- ▶ If permissible, use a low-resistance brake resistor.

7 Troubleshooting and fault elimination

Error	Cause	Remedy
Green LED is not lit	No voltage at terminals +U _G , -U _G	<ul style="list-style-type: none"> • Switch on mains • Connect braking unit to the terminals +U_G, -U_G of the controller
Controller sets pulse inhibit in braking operation and reports overvoltage <ul style="list-style-type: none"> • Yellow LED is not lit 	Braking unit not connected to the terminals +U _G , -U _G of the controller	Connect braking unit to the terminals +U _G , -U _G of the controller
	Switching threshold set incorrectly (switch S1, S2)	Adapt switching thresholds of braking unit and controller to the mains voltage (see chapter 5.3.9)
<ul style="list-style-type: none"> • Yellow LED is lit 	Brake resistor not connected	Connect brake resistor
	Brake resistor dimensioned with a too high impedance	Use low-resistance brake resistor (if permissible), possibly connect several braking units in parallel
Irregular heating of the brake resistors during parallel operation of several braking units	Braking units that are connected in parallel are not connected to terminals +U _G , -U _G of the controller(s)	Connect braking units to terminals +U _G , -U _G of the controller(s)
	Brake resistor not connected	Connect brake resistor
	Synchronisation not connected	Connect synchronisation (see chapter 5.4)
	Switching thresholds of the braking units which are connected in parallel are not set equally (switch S1, S2)	Adapt switching thresholds of braking unit and controller to the mains voltage (see chapter 5.3.9)
	Braking units not configured correctly as master/slave	Correct configuration (see chapter 5.4)
	Switching threshold(s) of the braking unit(s) set incorrectly (switch S1, S2)	Adapt switching thresholds of braking unit and controller to the mains voltage (see chapter 5.3.9)
Yellow LED is lit continuously, the brake resistor is overheating	Resistor is dimensioned incorrectly	<ul style="list-style-type: none"> • Select appropriate resistor for the drive. • For use of 9351: <ul style="list-style-type: none"> – Possibly use 9352.
	Switching threshold of the braking unit set incorrectly (switch S1, S2)	Adapt switching thresholds of braking unit and controller to the mains voltage (see chapter 5.3.9)

8 Appendix

Accessories

Rating for Lenze brake resistors

8 Appendix

8.1 Accessories

8.1.1 Rating for Lenze brake resistors

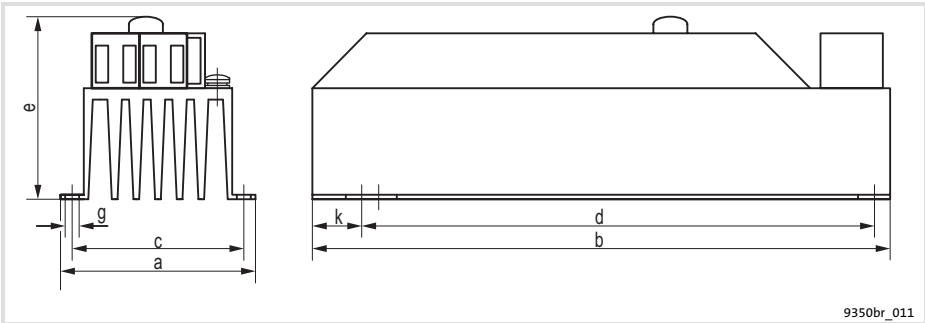

Fig. 12 Resistor modules with integrated temperature monitoring (50 to 200 W)

Resistance	Rated power	Order No.	a	b	c	d	e	g	k
[Ω]	[W]		[mm]	[mm]	[mm]	[mm]	[mm]	[mm]	[mm]
470	50	ERBM470R050W	60	240	50	225	60	5	7.5
470	100	ERBM470R100W	70	240	50	225	60	5	7.5
200	100	ERBM200R100W	80	160	70	145	95	5	7.5
370	150	ERBM370R150W	80	240	70	225	95	5	7.5
100	150	ERBM100R150W	80	240	70	225	95	5	7.5
240	200	ERBM240R200W	80	340	70	325	70	5	7.5
82	200	ERBM082R200W	80	340	70	325	70	5	7.5

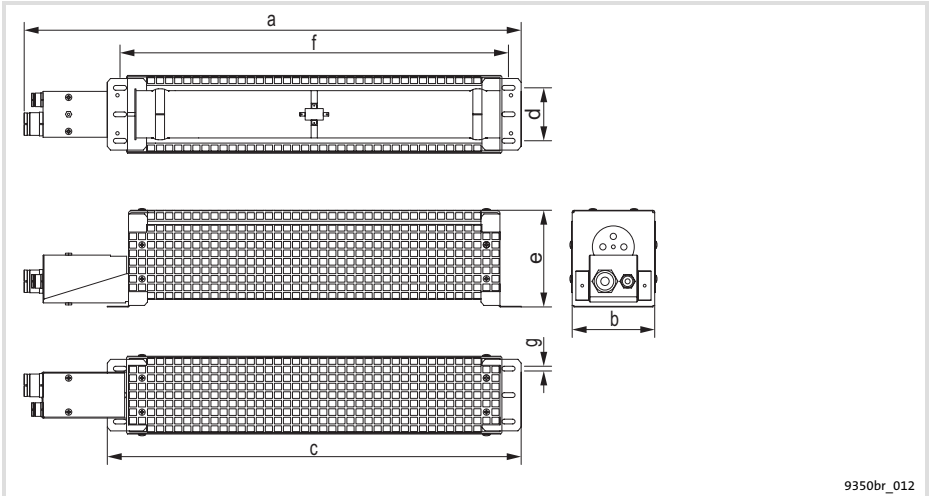

Fig. 13 Grid-protected wire-wound resistors with integrated temperature monitoring

Resistance	Rated power	Order No.	a	b	c	d	e	f	g
[Ω]	[W]		[mm]	[mm]	[mm]	[mm]	[mm]	[mm]	[mm]
180	300	ERBD180R300W	440	89	354	64	115	326	6.5
100	600	ERBD100R600W	640	89	554	64	115	526	6.5
82		ERBD082R600W							
68	800	ERBD068R800W	540	177	454	150	115	426	13
47	1200	ERBD047R01K2	640	177	554	150	115	526	13
33	2000	ERBD033R02K0	640	265	554	240	115	526	13
22	3000	ERBD022R03K0	740	177	654	150	229	626	13
18		ERBD018R03K0							

8.2 Glossary

Term	Meaning
Controller	General designation for servo drives (93XX), frequency inverters (82XX, 86XX) and DC drives (48XX, 49XX)
IMP	Pulse inhibit
Pictograph	Pictorial marking or symbol with clear information
PTC	PTC thermistor (PTC: positive temperature coefficient)
RB	Brake resistor
Residual hazard	Dangers that cannot be avoided by specific designs
Peak braking power	Maximum power which a resistor can convert into heat for a short time
Use	<ul style="list-style-type: none"> • Intended: <ul style="list-style-type: none"> – Appropriate use of the machine according to the manufacturer's information or according to common use because of its design and function. • Improper: <ul style="list-style-type: none"> – Any other use which is not intended.

8.3 Index

9351 brake module, 9

9352 brake chopper, 9

A

Ambient conditions

- climatic, 20

- mechanical, 20

Application, as directed, 10

Application as directed, 10

Application range, 5

B

Brake resistor, 48

Brake resistors, assignment table, 22

Braking unit, 9

- parallel connection, 40

Braking units, 21

C

Cable cross-sections, 22

Cable lengths, permissible, 32

CE conformity, 10

Cold plate, variant, 27

Commissioning, 46

Conformity, 10

Connection, 32

Controller, 9

- application as directed, 10

- labelling, 10

D

Default setting, switch S1/S2, 39

Definition of notes used, 18

Definitions of terms, 9

Display

- LED, 46

- operating status, 46

Disposal, 15

E

Electrical installation, 30

F

Features, 19

Fuses, 22

Fusing, 22 , 34

G

Gases, aggressive, 23

General data, 20

I

Installation, mounting, 29

Installation, electrical, 30

Installation, mechanical, 23

L

Labelling, controller, 10

LED, 46

Legal regulations, 10

Liability, 11

M

Manufacturer, 10

Master/slave, 40

Mechanical installation, 23

Mounting, 29

- cold-plate design, 27
- standard installation (with fixing rails), 24
- thermally separated (push-through technique), 25

Mounting clearance, 23

N

Notes, definition, 18

O

Operating conditions, 20

- ambient conditions
 - climatic, 20
 - mechanical, 20

Operating notes, 46

Operating status, display, 46

P

Parallel connection, braking unit, 40

Permissible cable lengths, 32

Pollution, 20

Protection of persons, 17

Push-through technique, 25

R

Rating, Brake resistors, 48

Residual hazards, 17

S

Safety instructions, 12

- Definition, 18
- Structure, 18

Scope of supply, 4

Site altitude, 20

Switch, S3, 40

- master/slave, 41

Switch S1/S2, 39

Switching threshold, 39

Synchronisation interface, 40

T

Technical data, 19

Temperature monitoring, 34

Terminology used, 9

Troubleshooting and fault elimination, 47

V

Variant, cold plate, 27

W

Warranty, 11

Lenze Drive Systems GmbH
Hans-Lenze-Straße 1
D-31855 Aerzen
Germany



+49 (0) 51 54 82-0



Service 00 80 00 24 4 68 77 (24 h helpline)



Service +49 (0) 51 54 82-1112

E-Mail Lenze@Lenze.de

Internet www.Lenze.com

EDBMB935X
EN 8.0
© 08/2008
TD34

