

Technical Documentation

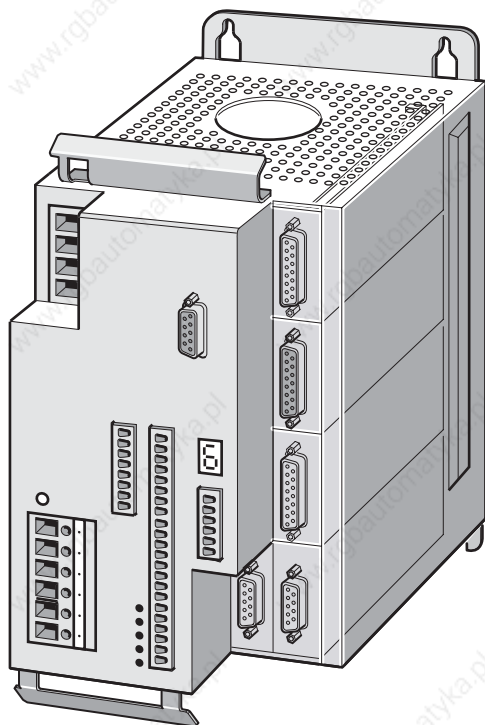

Twin Line Controller 53x

Controller for AC synchronous servomotors

TLC53x

Order no.: 0098 441 113 111

Edition: V1.00, 07.2004

Berger Lahr GmbH & Co. KG
Breslauer Str. 7
D-77933 Lahr

Important information

The drive systems described here are products for general use that conform to the state of the art in technology and are designed to prevent any dangers. However, drives and drive controllers that are not specifically designed for safety functions are not approved for applications where the functioning of the drive could endanger persons. The possibility of unexpected or unbraked movements can never be totally excluded without additional safety equipment. For this reason personnel must never be in the danger zone of the drives unless additional suitable safety equipment prevents any personal danger. This applies to operation of the machine during production and also to all service and maintenance work on drives and the machine. The machine design must ensure personal safety. Suitable measures for prevention of property damage are also required.

For more information see the chapter on safety.

Not all product types are available in all countries. Please see the current catalogue for the availability of products.

We reserve the right to make technical changes.

All information refers to specifications and not to assured properties.

Most product designations are registered trademarks of their proprietors, even when not specifically noted.

Table of Contents

Important information	-2
Table of Contents	-3
Writing conventions and symbols	-9
1 Introduction	
1.1 Scope of supply	1-2
1.1.1 Controller, IP20 type	1-2
1.1.2 Controller, IP54 type	1-3
1.2 Type code	1-4
1.3 Unit overview	1-5
1.4 Modules	1-8
1.5 Module configuration, operating modes and functions	1-10
1.6 Documentation and literature references	1-13
1.7 Directives and standards	1-14
1.8 Declaration of conformity	1-16
2 Safety	
2.1 Qualification of personnel	2-1
2.2 Intended use	2-1
2.3 Hazard categories	2-2
2.4 General safety instructions	2-3
2.5 Monitoring functions	2-4
3 Technical Data	
3.1 Environmental conditions	3-1
3.2 Mechanical data	3-2
3.2.1 IP20 controller	3-2
3.2.2 IP54 controller	3-3
3.2.3 Accessories	3-4
3.3 Electrical Data	3-5
3.3.1 Controller	3-5
3.3.2 Modules	3-7
3.3.3 UL 508C approval	3-10
3.3.4 Accessories	3-11
4 Installation	
4.1 Electromagnetic compatibility, EMC	4-1
4.2 System components	4-4

4.3	Mechanical installation	4-5
4.3.1	Installing IP20 controller.	4-5
4.3.2	Installing IP54 controller.	4-6
4.3.3	Attaching labels	4-7
4.3.4	Installing accessory components of the IP20 controller. 4-9	
4.3.5	Installing accessory components of the IP54 controller. 4-10	
4.4	Electrical installation	4-11
4.4.1	Electrical installation of IP54 controller	4-13
4.4.2	Mains connection for single-phase units	4-15
4.4.3	Mains connection for three-phase units	4-17
4.4.4	Motor connection on IP20 controller	4-19
4.4.5	Motor connection IP54 controller	4-22
4.4.6	Connection for parallel operation of two units	4-24
4.4.7	Connecting the 24 V supply voltage	4-26
4.4.8	Connection to the signal interface	4-28
4.4.9	Connection to the RS232 interface	4-35
4.4.10	Connection to the RS422-C module	4-37
4.4.11	Connection to the PULSE-C module	4-39
4.4.12	Connection to the IOM-C module	4-43
4.4.13	Connection to the HIFA-C module	4-45
4.4.14	Connection to the RESO-C module	4-47
4.4.15	Connection to the ESIM3-C module	4-49
4.4.16	Connection to the SAM-C module	4-51
4.4.17	Connection to the PBDP-C module	4-51
4.4.18	Connection to the CAN-C module	4-53
4.4.19	Connection to the RS485-C module	4-56
4.4.20	Connection to the MODB-C module	4-58
4.4.21	Connection to the IBS-C module	4-60
4.5	Connecting accessories to the IP20 controller	4-62
4.5.1	TLHBC holding brake controller.	4-62
4.5.2	Ballast resistor and control.	4-64
4.6	Wiring examples	4-71
4.6.1	Field-bus mode, Field bus configuration via inputs	4-71
4.6.2	Field-bus mode, configuration with TLHMI or TLCT	4-73
4.6.3	Field-bus mode, manual setup.	4-75
4.7	Checks	4-77
5	Commissioning	
5.1	General safety instructions	5-1
5.2	Overview.	5-2
5.3	Tools for commissioning	5-3
5.3.1	TLHMI hand-held operating unit	5-3
5.3.2	TLCT commissioning software.	5-5
5.4	Commissioning procedure	5-7
5.4.1	Preparation of controller.	5-7

5.4.2	Reading in the motor data	5-9
5.4.3	Checking the signals of limit switches	5-11
5.4.4	Checking holding brake	5-12
5.4.5	Setting device parameters	5-13
5.4.6	Setting and testing signal interface.	5-17
5.4.7	Setting device parameters for rotary encoder.	5-21
5.4.8	Test mode of motor with manual movement.	5-23
5.5	Optimising the controller	5-26
5.5.1	Controller structure	5-26
5.5.2	Configuring the optimisation utility	5-28
5.5.3	Optimising the speed controller	5-31
5.5.4	Procedure A: Rigid mechanism and known moments of inertia	5-33
5.5.5	Procedure B: Ziegler Nichols	5-34
5.5.6	Procedure C: Aperiodic limiting case	5-36
5.5.7	Checking and optimising default settings	5-39
5.5.8	Optimising the position controller	5-41

6 Operating modes of the controller

6.1	Operating modes.	6-1
6.1.1	Access channels.	6-2
6.1.2	Access control for selecting operating mode or function	6-2
6.1.3	Selecting the operating mode	6-4
6.1.4	Monitoring the set operating mode	6-5
6.1.5	Status monitoring in movement mode	6-8
6.2	Manual movement.	6-10
6.3	Speed mode	6-15
6.4	Point-to-point mode	6-17
6.5	Electronic gear	6-19
6.5.1	Gear settings	6-21
6.5.2	Synchronisation with compensatory movement	6-24
6.5.3	Offset positioning	6-25
6.6	Referencing.	6-28
6.6.1	Reference movement	6-30
6.6.2	Reference movement without index pulse.	6-31
6.6.3	Reference movement with index pulse.	6-36
6.6.4	Referencing by dimension setting.	6-42
6.7	Current control.	6-45
6.8	Oscillator mode	6-50

7 Functions of the controller

7.1	List control and list processing	7-1
7.2	Teach-in processing	7-7
7.3	Calibration	7-10
7.3.1	Calibration factor.	7-10

7.3.2	Setting calibration factors	7-12
7.3.3	Residual value in user-defined calibration	7-16
7.4	Ramp function	7-18
7.5	Quick-Stop function	7-20
7.6	StopMotion	7-22
7.6.1	Control word for state change	7-22
7.6.2	Reactions on movement interruption by StopMotion	7-22
7.7	Standstill window	7-24
7.8	Reversal of direction of rotation	7-26
7.9	Fast position capture	7-28
7.10	Monitoring functions	7-30
7.10.1	Monitoring of axis signals	7-30
7.10.2	Monitoring internal signals	7-33
7.10.3	Commutation monitoring	7-35
7.10.4	Monitoring communications with Fieldbus	7-36
7.11	Braking function with TLHBC	7-38
7.12	Additional analogue interfaces	7-41
7.13	Position control with additional incremental encoder	7-44
7.14	Setting parameters of the ESIM resolution	7-45
8	Diagnostics and troubleshooting	
8.1	Operational status indicators and transitions	8-1
8.2	Diagnosis during commissioning	8-3
8.3	Error display and troubleshooting	8-4
8.4	Table of error numbers	8-11
8.4.1	Error numbers from E1001 to E14FF	8-11
8.4.2	Error numbers from E1500 to E1CFF	8-14
8.4.3	Error numbers from E2000 to E20FF	8-23
9	Parameters	
9.1	Parameter groups	9-1
9.2	Parameter display	9-2
9.3	Overview Parameters	9-4
9.3.1	Parameter group "Settings"	9-4
9.3.2	Parameter group "Commands"	9-6
9.3.3	Parameter group "PA"	9-6
9.3.4	Parameter group "Servomotor"	9-8
9.3.5	Parameter group "CtrlBlock1..CtrlBlock2"	9-11
9.3.6	Parameter group "Motion"	9-12
9.3.7	Parameter group "Manual"	9-13
9.3.8	Parameter group "VEL"	9-14
9.3.9	Parameter group "PTP"	9-14

9.3.10	Parameter group "Gear"	9-15
9.3.11	Parameter group "Home"	9-16
9.3.12	Parameter group "CurrentControl"	9-17
9.3.13	Parameter group "Oscillator"	9-18
9.3.14	Parameter group "Teach-In"	9-19
9.3.15	Parameter group "List"	9-20
9.3.16	Parameter group "List1Data0..List1Data63"	9-21
9.3.17	Parameter group "List2Data0..List2Data63"	9-21
9.3.18	Parameter group "Capture"	9-22
9.3.19	Parameter group "I/O"	9-23
9.3.20	Parameter group "M1"	9-24
9.3.21	Parameter group "M2"	9-26
9.3.22	Parameter group "M3"	9-26
9.3.23	Parameter group "M4"	9-26
9.3.24	Parameter group "Status"	9-28
9.3.25	Parameter group "ErrMem0"	9-35

10 Accessories and spare parts

11 Service, maintenance and disposal

11.1	Service address	11-2
11.2	Shipping, storage, disposal	11-2

12 Glossaries

12.1	Terms and Abbreviations	12-1
12.2	Product name	12-6

13 Index

Writing conventions and symbols

Instructions for use Introduction to the following instruction steps

- ▶ This is the 1st step
- ◁ This is the response to the 1st step
- ▶ This is the 2nd step
- ◁ This is the response to the 2nd step

Instructions consist of an introduction and the actual instruction steps.

Unless otherwise stated, the individual instruction steps must be carried in the given sequence.

If there is an important response to an instruction step, this response is described after the instruction step. In this way you can check that the step was correctly completed.

List symbol Note on the contents of the list

- 1st list item
- 2nd list item
 - 1st list subitem
 - 2nd list subitem
- 3rd list item

The actual list follows a note on the contents of the list. It can consist of 1 or 2 levels.

The list items are sorted alphanumerically or by priority.

User notes User notes contain general information, not safety instructions.



This shows additional information on the current subject.

See the chapter on safety for an explanation of the safety instructions.

Parameters Parameters are shown as follows:

Group.Name Index:Subindex

1 Introduction

The controller is a component of the Twin Line unit range for control of stepper motors and AC servomotors. The controller with integrated controller and power circuit operates as a standalone power amplifier or in the field bus interconnection. It can control positioning on an AC synchronous servomotor and carry out positioning operations on its own.

The controller is available in four power levels with similar case design. Electrical connections and functional scope are identical for all four units.

The controller is available in two types with identical functions:

- IP20 variant, in degree of protection IP20, for use in a switch cabinet
- IP54 variant, in degree of protection IP54 (category 2 under EN 60529), for use without switch cabinet near the motor.

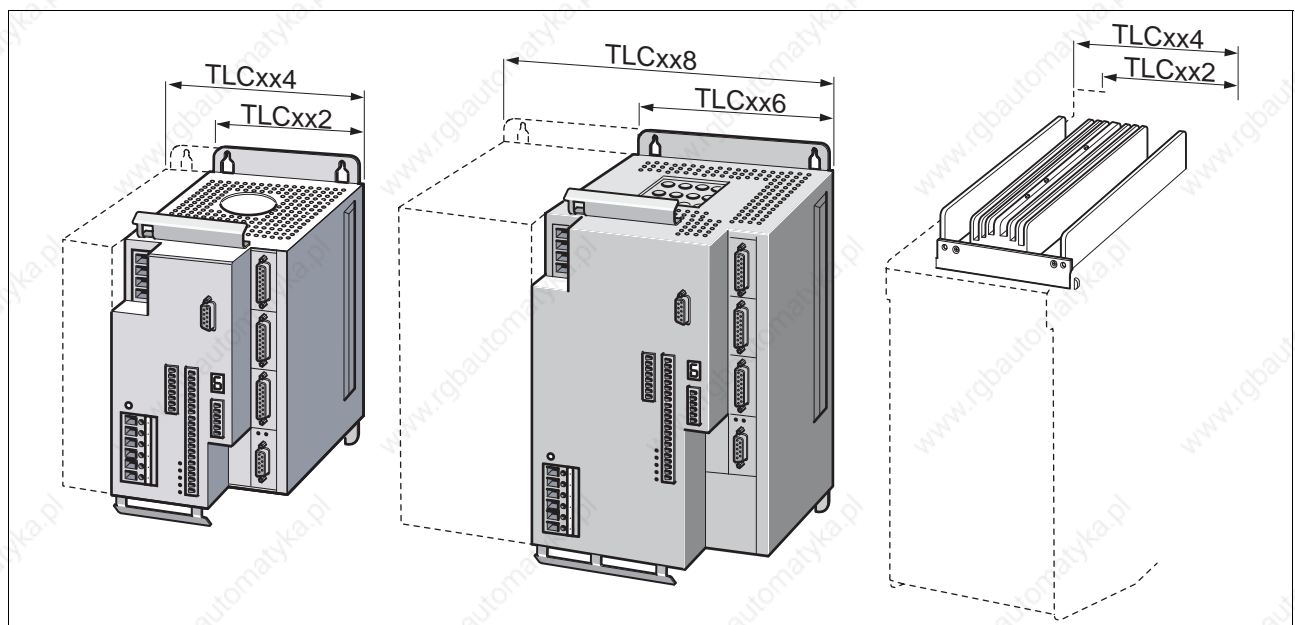

Figure 1.1 IP20 controller (left and centre) and IP54 controller (right)

1.1 Scope of supply

1.1.1 Controller, IP20 type

Controller

Item	Designation	Order number
1	Controller, IP20 variant	see type code
2	Hood for front cover	-
3	SK14 shielding terminal (two shielding terminals on units without internal mains filter)	see accessories
4	Connector caps for the terminal strips	-
5	Documentation on CD-ROM multilingual	see accessories

Optional module configuration

Item	Designation	Order number
6	RS422-C encoder module or PULSE-C pulse/direction module or IOM-C analogue module	see type code
7	HIFA-C Hiperface module or RESO-C resolver module	see type code
8	ESIM3-C module or SAM-C module	see type code
9	PBDP-C field bus module or CAN-C field bus module or RS485-C field bus module or MODB-C field bus module or IBS-C field bus module	see type code

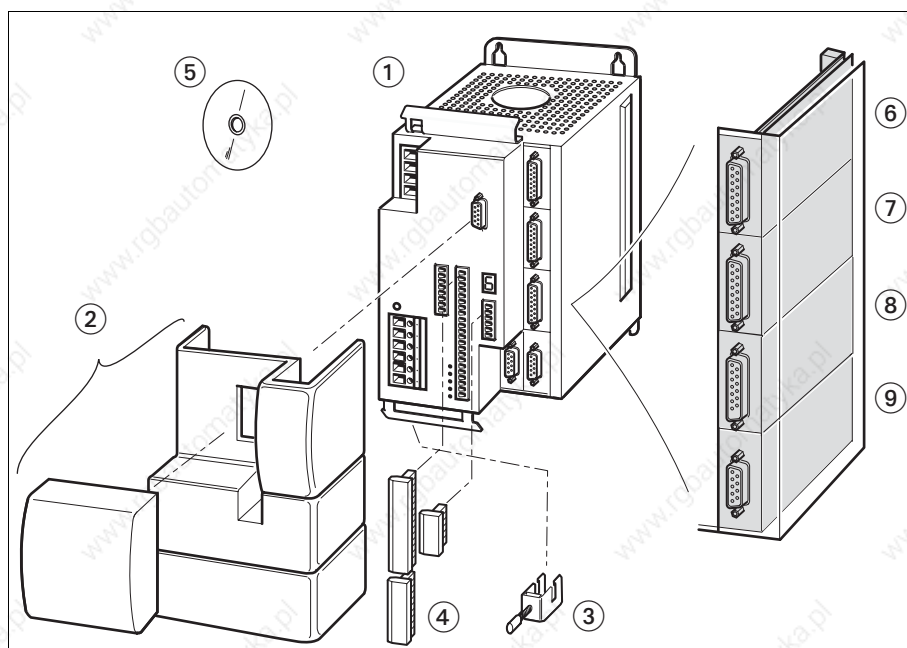

Figure 1.2 IP20 controller and modules

1.1.2 Controller, IP54 type

Controller

Item	Designation	Order number
1	Controller, IP54 variant	see type code
2	Power plug (round plug, 4-pin)	-
3	SK14 shielding terminal	see accessories
-	Sub-D cover for RS232 interface	-
4	Insulation sleeve for control connection of holding brake	-
5	Documentation on CD-ROM multilingual	see accessories
-	integrated holding brake controller optional	see type code

Optional module configuration

Item	Designation	Order number
6	RS422-C encoder module or PULSE-C pulse/direction module or IOM-C analogue module	see type code
7	HIFA-C Hiperface module or RESO-C resolver module	see type code
8	ESIM3-C module or SAM-C module	see type code
9	PBDP-C field bus module or CAN-C field bus module or RS485-C field bus module or MODB-C field bus module or IBS-C field bus module	see type code

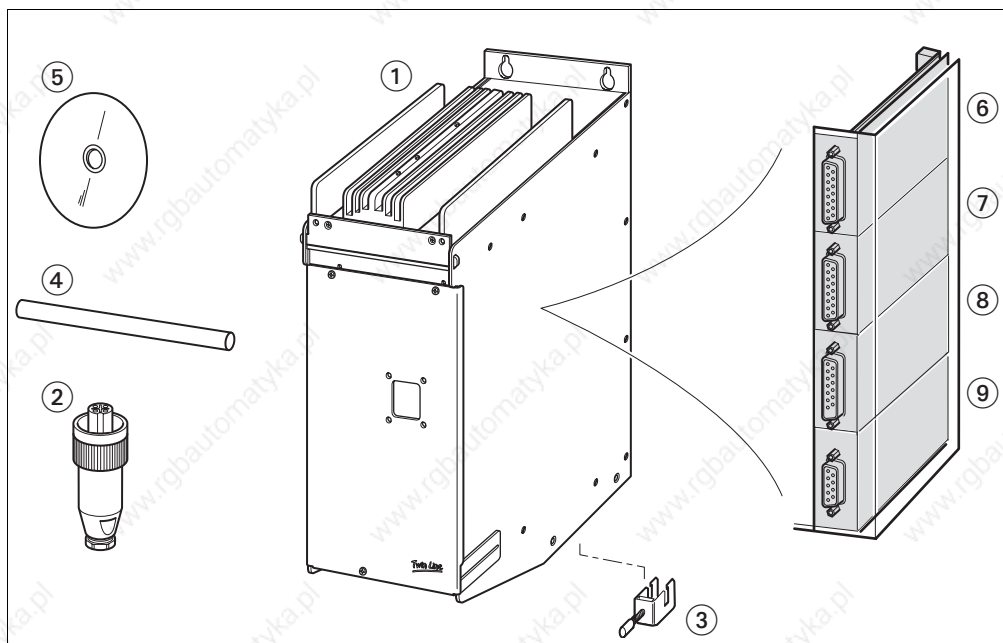

Figure 1.3 IP54 controller and modules

1.2 Type code

Example:	TLC	x	3	x	x	x	x	x	x	x	x
Twin Line Controller	TLC	x	x	x	x	x	x	x	x	x	x
4 - with data set operation	TLC	x	3	x	x	x	x	x	x	x	x
5 - with field bus											
6 - programmable											
for AC servomotors	TLC	x	3	x	x	x	x	x	x	x	x
Power class	TLC	x	3	x	x	x	x	x	x	x	x
2 - 750 W											
4 - 1500 W											
6 - 3000 W											
8 - 8000 W											
F - IP20 controller with built-in line power filter	TLC	x	3	x	x	x	x	x	x	x	x
NF - IP20 controller without built-in line power filter											
PF - IP54 controller with built-in line power filter											
Reference quantities at M1	TLC	x	3	x	x	x	x	x	x	x	x
RS422 - A/B-signals											
Pulse - P/R-, P _V /P _R -signals											
IOM - analog module											
-- N/A											
Motor position detection on M2	TLC	x	3	x	x	x	x	x	x	x	x
HIFA - SinCos-encoder											
RESO - resolver											
Encoder simulation on M3	TLC	x	3	x	x	x	x	x	x	x	x
ESIM3 - encoder simulation											
SAM - safety module											
-- N/A											
Communication on M4	TLC	x	3	x	x	x	x	x	x	x	x
PBDP - Profibus DP											
CAN - CAN-Bus											
RS485 - serial bus											
ModBus - serial bus											
IBS - Interbus											
Built-in holding brake control on M5 (only IP54)	TLC	x	3	x	x	x	x	x	x	x	x
HBC - Holding brake controller											
-- N/A											

1.3 Unit overview

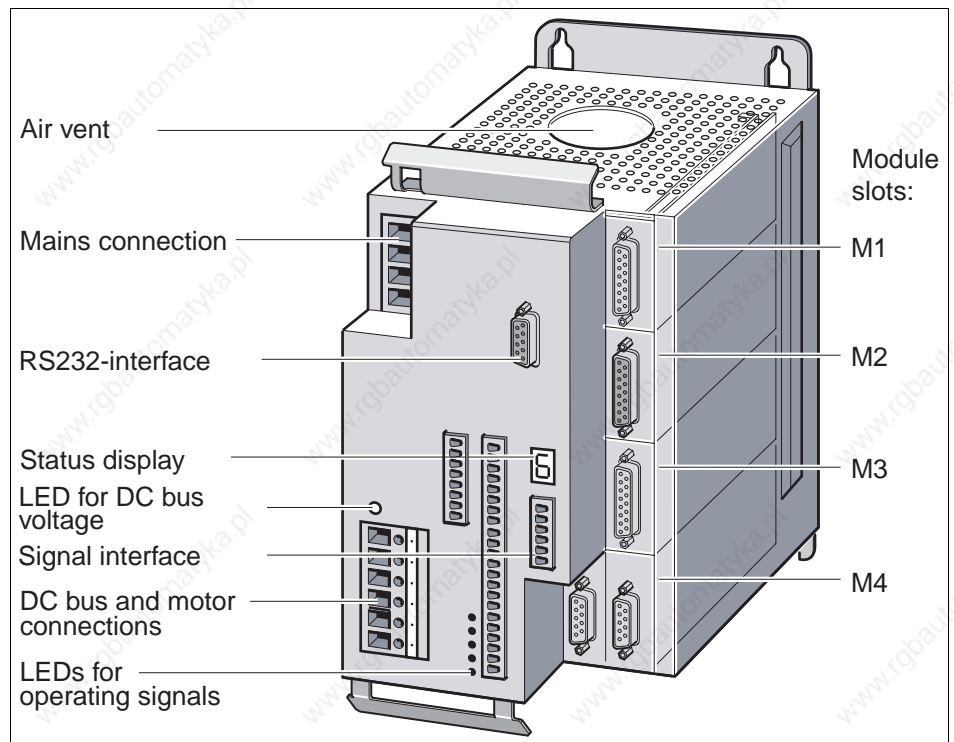

Figure 1.4 IP20 controller

Mains connection The supply voltage for the power amplifier is connected to the mains connection.

A position controller with a built-in line power filter can be operated without any further noise suppression on the supply side.

The power supply for closed-loop control and fan control must be connected over an external 24 V_{DC} power supply. This voltage must be earthed for correct function.

Motor connection The controller supplies the current for a permanent-field AC synchronous servomotor over the three-phase connection. The motor connection is short-circuit resistant and is tested for earth faults when the power amplifier is enabled.

Internal ballast resistor In braking mode the motor returns energy to the controller. The energy is absorbed by DC bus capacitors and reduced by the internal ballast resistor.

Housing earth In addition to the earth at the mains connection an earth connection is also available on the housing (EN50178 requirements for devices with high leakage currents).

DC bus connection The DC bus voltage of the unit is lead out at the DC bus connection. If the internal ballast resistor is not sufficient to discharge the excess energy as heat, a ballast resistor controller with an external ballast resistor can be connected to the DC bus connection on a standard unit.

Status display A seven segment display shows information on the operating status of the controller. If there is an operating malfunction the display will flash and display an error code.

<i>LED for DC bus voltage</i>	The LED comes on when DC bus voltage is present.
<i>LEDs for operating signals</i>	Five LEDs display the signal states of these adjacent inputs: Positive and negative limit switches, motor stop signal, power amplifier enable and automatic operation.
<i>Signal interfaces</i>	The input and output signals are routed via contacts to the signal interface and an external 24 V _{DC} power supply is fed for the closed-loop control unit.
<i>RS232 interface</i>	The RS232 port is the communications interface of the Twin Line unit for connecting a PC or the TLHMI hand-held operating unit.
<i>Air outlet and fan</i>	A built-in fan feeds cool air into the unit from below to cool the power amplifier and ballast resistor. It discharges the warmed air through the upper air vents. Temperature sensors on the power amplifier's heat sink protect the unit from overheating.
<i>Module slots</i>	<p>The controller is adjusted flexibly to the desired type of operation with the module slots. The minimum configuration required to drive an AC servomotor is a module in slot M2. The remaining slot modules extend the functions of the controller.</p> <p>The modules are not designed for configuration by the customer. Order the unit with desired modules. Changes to the module configuration in the field are not recommended.</p>
<i>Parameter memory</i>	All controller settings are administered in one motor data set, two data sets for controller parameters and one data set for motion parameters. The parameters are saved in non-volatile memory in the unit protected against power failure and can be displayed and modified through the RS232 interface on the PC, the TLHMI hand-held operating unit or the field bus.
<i>Motor data set</i>	The motor data set is read in automatically at the start of commissioning and after a change of motor or is selected with the commissioning software.
<i>Controller parameters</i>	The two controller parameter sets contain two independent controller settings. The user can switch between the blocks over the various access channels. The parameter values of both sets are preset and can be optimised for operation in the system.
<i>Movement parameters</i>	The movement parameter set contains specific data for the various operating modes of the controller. Should the operating mode change, the controller will switch over to the appropriate set of movement parameters.

Memory for device data

Device data are all parameter values of the Twin Line unit that can be stored in the EEPROM memory of the Twin Line unit safe from power outages.

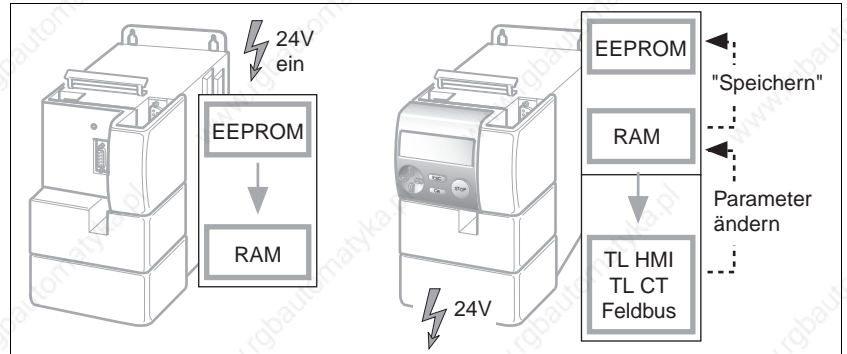

Figure 1.5 Memory ranges and parameter backup

Once the 24 V power supply is switched on, the parameters are automatically copied to the Twin Line unit RAM from the internal EEPROM memory. The Twin Line unit operates with the RAM device data only.

The following options are available to back up parameters from RAM to the EEPROM:

- with the TLHMI hand-held operating unit: back up with the menu item "Save"
- with the TLCT commissioning software: back up with special button fields and menu items
- via the field bus: back up with the parameters 'Commands.eeprSave'

1.4 Modules

The block diagram shows the modules and interface signals of the controller.

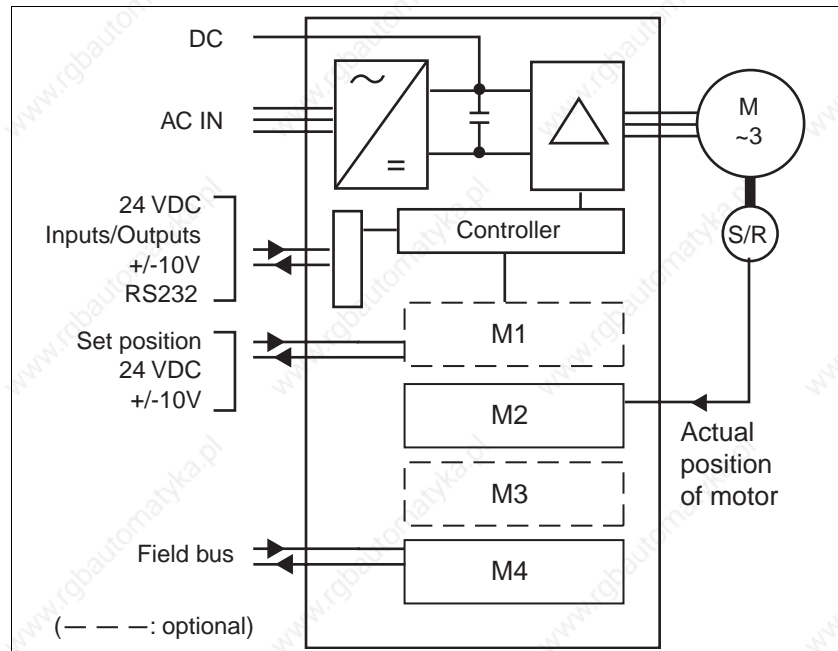

Figure 1.6 Block diagram with modules and interface signals

Slot M1

RS422-C module

The RS422-C encoder module captures externally fed A/B incremental encoder signals. The signals are received as A/B signals from a rotary encoder, a higher-level controller or from the encoder simulation of a first controller. Special case: If the position control has been set via M1, i.e. there is an additional incremental encoder at module slot M1 with RS422-C, the RS422-C encoder module will evaluate the received signals as the actual motor position.

PULSE-C module

The PULSE-C pulse-direction module sends externally fed frequency signals to the controller as reference signals for positioning. The module captures the positioning data as a pulse/direction signal or as a pulse_{forward}/pulse_{back} signal.

IOM-C module

The analogue module records and generates analogue and digital voltage values. The analogue outputs can be set by the user. The module outputs controller setpoints as analogue voltage values.

Slot M2

HIFA-C module

The HIFA-C Hiperface module is used for the position response on AC servomotors with Hiperface rotary encoders from the Stegmann company. A Hiperface rotary encoder captures the rotor position of the AC servomotor at high resolution and sends it to the Hiperface module as an analogue signal. The Hiperface module sends the position data to the closed-loop control and at the same time generates A/B signals for the encoder simulation with the ESIM3-C module.

RESO-C module

The RESO-C resolver module evaluates the position response when resolver motors are used. Like the HIFA-C Hiperface module the resolver

module also generates A/B signals for an encoder simulation or position information.

M3 slot

ESIM3-C module The ESIM3-C encoder simulation module sends the position data of the AC servomotor as an A/B signal.

SAM-C module The SAM safety module (safety monitor) allows safety functions for personnel protection to be integrated into the controller for protection against dangerous movements.

M4 slot

PBDP-C module The PBDP-C field bus module can be used to integrate the controller into the Profibus-DP field bus. The controller operates as a command recipient or as a slave. It executes the control and work commands received from a higher-order controller.

CAN-C module The CAN-C field bus module couples the controller to a CAN, CANOpen or DeviceNet field bus system.

RS485-C module The RS485-C field bus module enables field bus operation over a multipoint connection with serial data transfer. A multipoint connection, in contrast to a point-to-point connection, is able to swap data with several devices.

MODB-C module The MODB-C field bus module is used to integrate the controller into a ModBus-ASCII or ModBus-RTU field bus network.

IBS-C module The IBS-C field bus module enables the controller to be used as a slave in an Interbus network. The field bus module is optional. The module is designed to Interbus specification version 1.

1.5 Module configuration, operating modes and functions

Overview The controller operates in one manual and several automatic operating modes depending on the modules installed. The operating mode of the controller can be changed during movement.

Manual operating mode

- manual movement

Automatic operating modes:

- speed mode
- point-to-point mode
- electronic gear
- referencing
- current control
- oscillator mode

Module configuration The following table shows the minimum required module configuration for the operating modes and the optional configuration for additional functions.

Operating mode	M1	M2	M3	M4
manual movement, speed mode, point-to-point mode, referencing, current control, oscillator mode	optional	HIFA-C or RESO-C	optional	PBDP-C, CAN-C, RS485-C, MODB-C or IBS-C
electronic gear	PULSE-C or RS422-C	HIFA-C or RESO-C	optional	PBDP-C, CAN-C, RS485-C, MODB-C or IBS-C

Overview of manual movement Manual movement is carried out as 'classic manual movement' or as 'united inching'. In both operating modes the motor is moved over a prescribed distance by start signals.

Overview of speed mode In speed mode, a setpoint speed is specified for the motor over the profile generator, and movement is initiated with no defined target point. The motor moves at this speed until a different speed is set or the operating mode is terminated.

Overview of point-to-point mode In point-to-point mode (also PTP mode) the motor is positioned from point A to point B with a positioning command. The positioning distance is given either in absolute terms with reference to the reference point of the axis or in relative terms to the current position of the axis.

Overview of electronic gear In the electronic gear mode, the controller calculates a new position setpoint for the motor movement from a predefined position and an adjustable gear factor. This mode is used when one or more motors are to follow the reference signal from a NC control unit or an encoder.

- Overview of referencing* In referencing, an absolute scale reference of the motor position at a defined axis position is established. Referencing can be carried out by a referencing movement or by dimension setting.
- In a referencing movement, a defined position on the axis, the zero or reference point, is established as the absolute scale reference of the motor position to the axis. This reference point is used as the point of reference for all subsequent absolute positioning operations.
- Dimension setting allows the current motor position to be defined as the new axis reference point to which all subsequent position data relate.
- Overview of current control* In current control, the setpoint value of the motor current can be set either with parameters or the $\pm 10V$ input of the signal interface.
- Overview of oscillator mode* In oscillator mode the motor is moved in accordance with a voltage-dependent speed preset via the $\pm 10V$ input.
- When the input voltage is changed the drive accelerates or decelerates to the new setpoint speed with the specified acceleration and deceleration values.
- Overview of controller optimisation* Operating mode for commissioning the controller. Controller optimisation matches control behaviour to the particular system. Controller optimisation is also used to adapt the controller to a modified or new system. The controller uses a signal generator for controller optimisation.
- Controller optimisation can only be carried out manually with the optimisation tool. During optimisation, control parameters can be set and tested by means of a jump function.
- Overview of signal generator* A signal generator is specially integrated in the controller for fast commissioning. It can be used to optimise the operational behaviour of the AC servomotor in the system.
- The signal generator is a function which is only used during commissioning. It is enabled "in the background" to optimise the control-loop behaviour of the controller.
- Overview of field-bus mode* Five modules are available for operation on a field bus:
- Profibus-DP with the PBDP-C module
 - CAN-Bus, CANOpen or DeviceNet with the CAN-C module
 - serial RS485 bus with the RS485-C module
 - Interbus-S with the IBS-C module
 - ModBus with the MODB-C module
- See the relevant manuals for information on connection, programming and operation of the controller on the field bus.
- Overview of list control* While the controller executes a movement command, the traverse path is monitored in the background with the list control. When a list position is reached the controller responds with a corresponding event depending on the list type.
- List type for position values and signal values: If the motor reaches a list position, the output signal `TRIGGER` is set or reset corresponding to the list entry.
 - List type for position values and speed values: If the motor reaches a position value, the controller switches to the new speed value in the list and traverses the motor at this speed.

Overview of Teach-In

Teach-in processing offers the option of recording current position values by traversing the motor and transferring them to a previously specified memory range. The size of the available memory depends on the size of the free list memory. Up to 64 position entries can be saved if a list is empty.

The data are stored in a position/signal list or a position/speed list.

1.6 Documentation and literature references

- Manuals for the controller*
- TLHMI, documentation for the TLHMI hand-held operating unit
Order no.: see accessories
 - TLCT, documentation for the TLCT commissioning software
Order no.: see accessories

1.7 Directives and standards

The EC directives define the minimum requirements - particularly safety requirements - applicable to a product and must be complied with by all manufacturers and dealers marketing the product in the member states of the European Union (EU).

The EC directives describe the main requirements for a product. The technical details are laid down in the harmonized standards, which are published in Germany as the DIN EN standards. If there is not yet any EN standard applicable to a particular product area, existing technical standards and regulations will apply.

CE mark With the declaration of conformity and the CE mark on the product the manufacturer certifies that the product complies with the requirements of all relevant EC directives. The drive systems described here can be used anywhere in the world.

EC Machine Directive The drive systems described here are not machines as defined by the EC Machine Directive (89/392/EEC) but components for installation in machines. They do not have moving parts designed for specific purposes. However, they can be components of a machine or system.

The manufacturer must certify that the complete system conforms to the machine directive with the CE mark.

EC EMC Directive The EC Electromagnetic Compatibility Directives (89/336/EEC) applies to products that cause electromagnetic interference or whose operation may be adversely affected by electromagnetic interference.

Conformity with the EMC Directive can only be expected of our drive systems after correct installation in the machine. The information on ensuring electromagnetic compatibility given in the chapter on "Installation" must be followed to ensure that the drive system in the machine or system is EMC-compatible and that the product can legally be operated.

EC Low-Voltage Directive The EC Low-Voltage Directive (73/23/EEC) lays down safety requirements for 'electrical apparatus' as protection against the risks that can originate in such devices and can be created in response to external influences.

The drive systems described here comply with the EN 50178 Standard as per the Low-Voltage Directive.

Declaration of conformity The declaration of conformity certifies that the drive system complies with the specific EC directive.

<i>Standards concerning safe operation</i>	<p>EN 954-1: Safety of machinery - Safety-related parts of control systems - Part 1: General principles for design</p> <p>EN 50274: Low voltage switchgear and controlgear assemblies - Protection against electric shock</p> <p>IEC 60204-1: Safety of machinery - Electrical equipment of machines - Part 1: General requirements</p> <p>IEC 60364: Electrical installations of buildings</p> <p>IEC 60529: Degrees of protection provided by enclosures (IP code)</p> <p>IEC 61508-1: Functional safety of electrical/electronic/programmable electronic safety-related systems - Part 1: General requirements</p> <p>NEMA ICS1.1: Safety Guidelines for the Application, Installation, and Maintenance of Solid State Control</p> <p>NEMA ICS7.1: Safety Standards for Construction and Guide for Selection, Installation, and Operation of Adjustable-Speed Drive Systems</p> <p>NFPA 70: National Electrical Code</p> <p>NFPA 70E: Standard for Electrical Safety Requirements for Employee Workplaces</p> <p>NFPA 79: Electrical Standard for Industrial Machinery</p>
<i>Standards regarding compliance with EMC Directive</i>	<p>EN 61000-4: Electromagnetic compatibility (EMC) - Part 4: Testing and measurement techniques</p> <p>IEC 61800-3: Adjustable speed electrical power drive systems - Part 3: EMC product standard including specific test methods</p>
<i>Standards regarding compliance with Low Voltage Directive</i>	<p>EN 50178: Electronic equipment for use in power installations</p> <p>IEC 60664-1: Insulation coordination for equipment within low-voltage systems - Part 1: Principles, requirements and tests</p>
<i>Standards regarding compliance with Underwriters Laboratories requirements</i>	<p>UL508C 2nd Edition: UL Standard for Safety for Power Conversion Equipment</p> <p>UL840 2nd Edition: UL Standard for Insulation Coordination Including Clearances and Creepage Distances for Equipment</p> <p>UL1004 5th Edition: UL Standard for Safety for Electric Motors</p>

1.8 Declaration of conformity

<u>EC Declaration of Conformity</u> <u>Year 2004</u>		BERGER LAHR
		BERGER LAHR GmbH & Co.KG Breslauer Str. 7 D-77933 Lahr
<input checked="" type="checkbox"/> according to EC Directive EMC 89/336/EEC <input checked="" type="checkbox"/> according to EC Directive Low Voltage 73/23/EEC The above mentioned directives have been changed by CE Marking Directive 93/68/EEC <input type="checkbox"/> according to EC Directive on Machinery 98/37/EEC		
We declare that the products listed below meet the requirements of the mentioned EC Directives with respect to design, construction and version distributed by us. This declaration becomes invalid with any modification on the products not authorized by us.		
Designation:	3 Phase Motor Control Electronics and Accessories	
Type:	TLD, TLC, TLABH, TLABB, TLBRC, TLHBC	
Product number:	0x634xxxxxxxx, 0x635xxxxxxxx, 0x62501101706, 0x62501101606	
Applied harmonized standards, especially:	EN 50178:1998 EN 61800-3:2001 second environment according to Berger Lahr EMC test conditions	
Applied national standards and technical specifications, especially:	UL 508C Berger Lahr EMC test conditions 200.47-01 EN Product documentation	
Company stamp:	Berger Lahr GmbH & Co. KG Postfach 11 80 · D-77901 Lahr Breslauer Str. 7 · D-77933 Lahr	
Date/ Signature:	16 February 2004	
Name/ Department:	Wolfgang Brandstätter/R & D	

Figure 1.7 Conformity to the EC low-voltage directive

2 Safety

2.1 Qualification of personnel

Only technicians who are familiar with and understand the contents of this manual and the other relevant manuals are authorised to work on and with this drive system. The technicians must be able to detect potential dangers that may be caused by setting parameters, changing parameter values and generally by the mechanical, electrical and electronic equipment.

The technicians must have sufficient technical training, knowledge and experience to recognise and avoid dangers.

The technicians must be familiar with the relevant standards, regulations and safety regulations that must be observed when working on the drive system.

2.2 Intended use

The drive systems described here are products for general use that conform to the state of the art in technology and are designed to prevent any dangers. However, drives and drive controllers that are not specifically designed for safety functions are not approved for applications where the functioning of the drive could endanger persons. The possibility of unexpected or unbraked movements can never be totally excluded without additional safety equipment. For this reason personnel must never be in the danger zone of the drives unless additional suitable safety equipment prevents any personal danger. This applies to operation of the machine during production and also to all service and maintenance work on drives and the machine. The machine design must ensure personal safety. Suitable measures for prevention of property damage are also required.

In the system configuration described the drive systems must be used in industrial applications only and must have a fixed connection only.

In all cases the applicable safety regulations and the specified operating conditions, such as environmental conditions and specified technical data, must be observed.

The drive systems may be commissioned and operated only after installation in accordance with EMC requirements and the product-specific specifications.

To prevent personal injury and damage to property damaged drive systems must not be installed or operated.

Changes and modifications to the drive systems are not permitted and will render all warranties and liability null and void.

The drive system must be operated only with the specified wiring and approved accessories. In general, use only original accessories and spare parts.

The drive systems must not be operated in an environment subject to explosion hazard (ex area).

2.3 Hazard categories

Safety notes and general information are indicated by hazard messages in the manual. In addition there are symbols and instructions affixed to the product that warn of possible hazards and help to operate the product safely.

Depending on the seriousness of the hazard, the messages are divided into three hazard categories.



DANGER!

DANGER indicates an imminently hazardous situation, which, if not avoided, **will result** in death, serious injury, or equipment damage.



WARNING!

WARNING indicates a potentially hazardous situation, which, if not avoided, **can result** in death, serious injury, or equipment damage.



CAUTION!

CAUTION indicates a potentially hazardous situation, which, if not avoided, **can result** in injury or equipment damage.

2.4 General safety instructions



DANGER!

Electric shock, fire or explosion

- Only qualified personnel who are familiar with and understand the contents of this manual and the other relevant manuals are authorised to work on and with this drive system.
- Before working on the drive system:
 - Switch off power to all terminals.
 - Place a sign "DO NOT SWITCH ON" on the switch and lock to prevent switching on.
 - **Wait 6 minutes** (for discharge of DC bus capacitors).
 - Measure voltage between DC+ and DC- and check for <48V. (The DC bus LED is not a safe indication for absence of the DC bus voltage).
- Do not short-circuit DC bus or touch unshielded components or screws of the terminals with voltage present.
- Install all covers and close the housing doors before applying power.
- The motor generates voltage when the shaft is rotated. Lock the shaft of the motor to prevent rotation before starting work on the drive system.
- The system manufacturer is responsible for compliance with all applicable regulations relevant to earthing the drive system.
- Do not reach into the drive system (e.g. no pointed objects).



DANGER!

Danger of injury by complex system!

When starting field bus operation the attached controllers are generally out of view of the operator and cannot be directly monitored.

- Start the system only if there are no persons within the actuation zone of the moving system components and the system can be operated safely.



WARNING!

Danger of injury and damage to system components by loss of control!

- The system manufacturer must consider the possible errors that could occur with the signals and in particular the critical functions to ensure a safe status during and after errors. Critical functions include emergency stop and limiting end positions. Observe the accident prevention regulations.
- Consideration of possible errors must include unexpected delay and failure of signals or functions.
- Separate redundant controller paths must be provided for critical functions.

2.5 Monitoring functions

The monitoring functions in the drive protect the system and reduce the risk in the event of system malfunction. The monitoring functions are not designed for personal safety. The following faults and limit values can be monitored:

Monitoring	Task	Protective function
Blocking error	Error message if the motor shaft remains stopped over a specified period even with maximum current	Functional safety
Data connection	Error response to connection break	Functional safety and system protection
Limit switch signals	Monitoring the allowable traverse range	System protection
Following error	Monitoring deviation from motor position to setpoint position	Functional safety
STOP switch signal	Stop drive with Quick-Stop ramp	System protection
Motor overload	Monitoring for excessively high current in the motor phases	Functional safety and device protection
Overvoltage and undervoltage	Monitoring for overvoltage and undervoltage of the power supply	Functional safety and device protection
Overtemperature	Monitoring device for overtemperature	Device protection
I^2t limitation	Power limitation at overload	Device protection

Table 2.1 Monitoring functions

3 Technical Data

3.1 Environmental conditions

IP20 controller

Transport and storage temperature	40°C to +70°C
Installation height, operation without power reduction	h <1000 m above mean sea level
Degree of protection	IP20
Ambient temperature	0°C to + 50°C
Relative humidity	15% to 85% (non-condensing)
compliant with the Low Voltage Directive EN 50178	Protection class 1 Pollution degree 2

IP54 controller

Transport and storage temperature	40°C to +70°C
Installation height, operation without power reduction	h <1000 m above mean sea level
Degree of protection	IP54, category 2
Degree of protection of internal air duct for cooling	IP24
Ambient temperature	0°C to + 45°C
Relative humidity	15% to 85% (from serial number 1010020048 with protection against short-term condensation)
compliant with the Low Voltage Directive EN 50178	Protection class 1 Pollution degree 3

The IP54 controller can be operated outside the switch cabinet, but not outside and not in environments with serious adhesive pollution (blockage of fan).

Test conditions

Vibration during operation to IEC 68-2-6

Number of cycles:	10
Frequency range:	10 Hz to 500 Hz
Acceleration amplitude:	20 m/s ²

Continuous shock to IEC 68-2-29

Number of shocks:	1000/direction (directions: X, Y, Z per pos. and neg. direction, total 6000)
Peak acceleration:	150 m/s ²

3.2 Mechanical data

3.2.1 IP20 controller

Weight

TLxx32 with 3 modules [kg]	2.7 (6.0 lb.)
TLxx34 with 3 modules [kg]	3.7 (8.2 lb.)
TLxx36 with 3 modules [kg]	6.6 (14.6 lb.)
TLxx38 with 3 modules [kg]	10.8 (23.9 lb.)

Device protection

Degree of protection to EN 60529	IP 20
----------------------------------	-------

Dimensions

	TLxx32	TLxx34	TLxx36	TLxx38
Width A [mm]	108	128	178	248
Height B [mm]	212.5	212.5	260	260
Depth C [mm]	184.5	214.5	244.5	244.5
Front width D [mm]	105.5	125.5	176	246
Connection dimension E [mm]	63	83	130	200
Additional dimension F [mm]	-	-	-	120

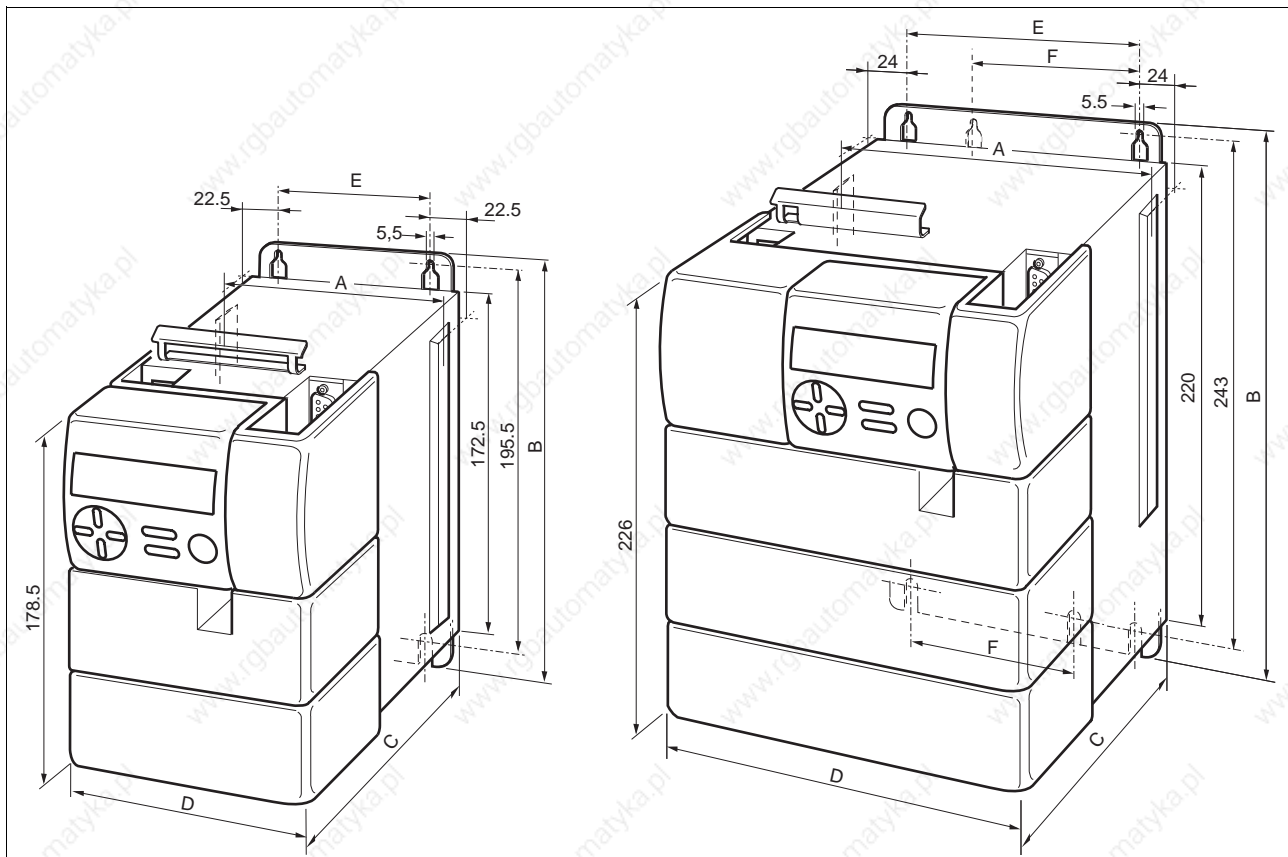

Figure 3.1 Dimensions IP20 controllers. The TLHMI hand-held operating unit illustrated is optional.

0098 441 113 110, V1.00, 07.2004

3.2.2 IP54 controller

Weight

TLCx32 with 3 modules [kg]	8.5 (18.8 lb.)
TLCx34 with 3 modules [kg]	11 (24.3 lb.)

Device protection

Degree of protection to EN 60529	IP 54, category 2
----------------------------------	-------------------

Dimensions

	TLCx32	TLCx34
Width A [mm]	127	147
Height B [mm]	360	360
Depth C [mm]	245	275
Front width D [mm]	127	127
Connection dimension E [mm]	80	100

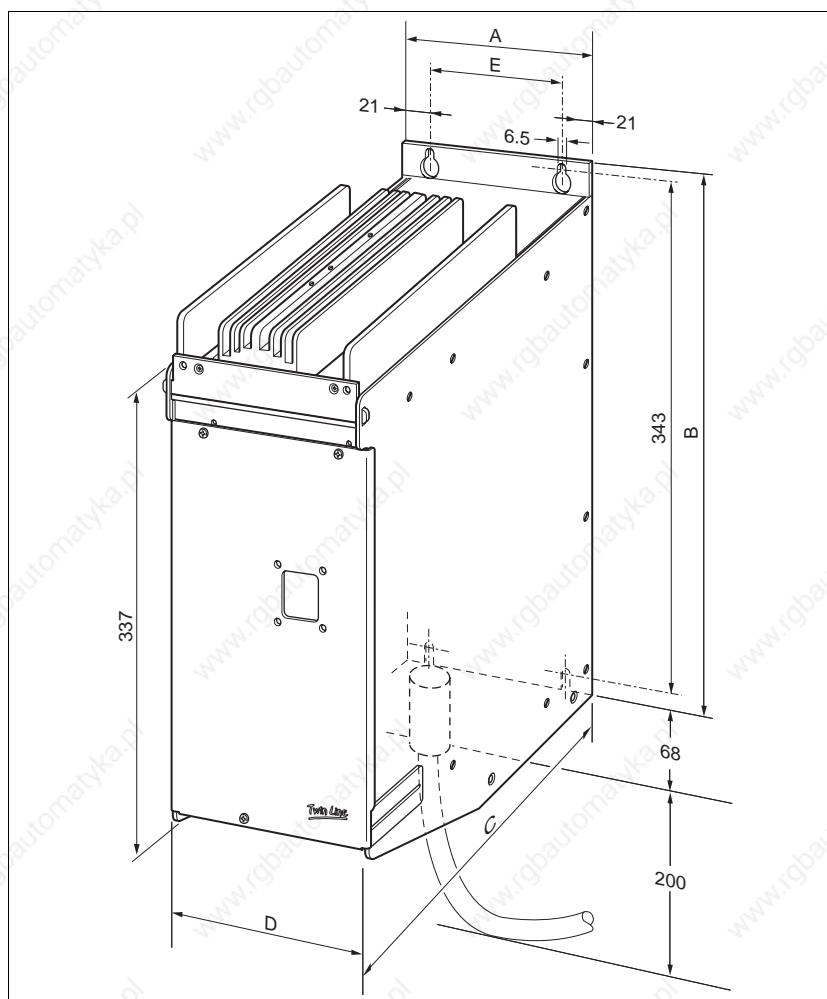

Figure 3.2 Dimensions IP54 controller

3.2.3 Accessories

*Holding brake controller
TLHBC*

Dimensions (H x B x T) [mm]	107 x 104 x 76
Installation on top-hat rail [mm]	55

*Ballast resistor controller
TLBRC*

Dimensions (H x B x T) [mm]	107 x 104 x 76
2 DC bus connections	
Installation on top-hat rail [mm]	55

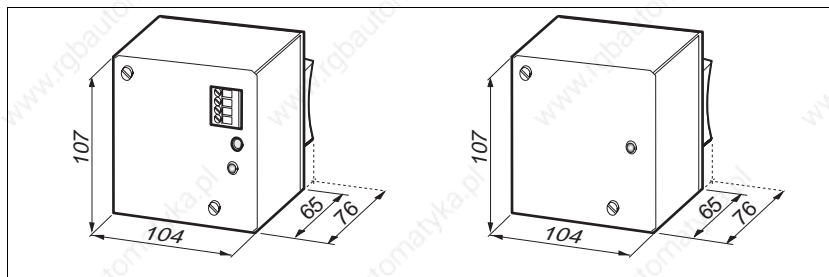

Figure 3.3 Holding brake controller and ballast resistor controller

*Ballast resistor BWG250xxx and
BWG500xxx*

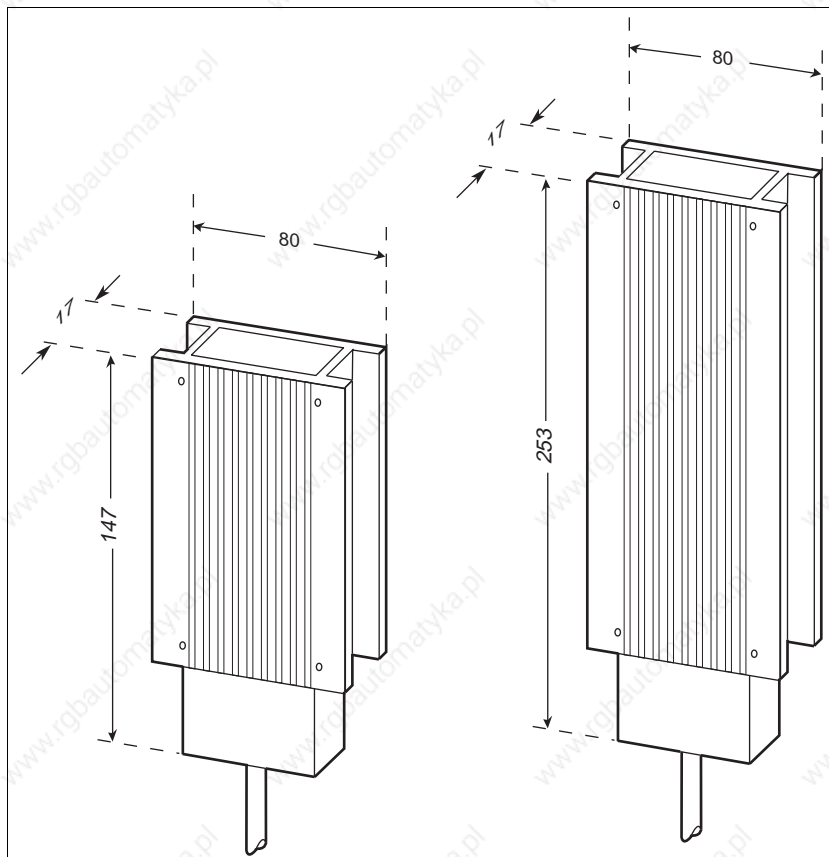

Figure 3.4 Dimensions and installation size of the 100 W and 200 W ballast resistor

0098 441 113 110, V1.00, 07.2004

3.3 Electrical Data

3.3.1 Controller

Mains connection

	TLxx32	TLxx34	TLxx36	TLxx38
Mains voltage [V _{AC}] (-20%, +10% ¹⁾)	230 - 240 (115 ²⁾)	230 - 480	230 - 480	230 - 480
Mains phases	1	3	3	3
Mains frequency [Hz]	47 - 63	47 - 63	47 - 63	47 - 63
Current consumption [A] ³⁾	6.5 (10 ²⁾)	4	7.5	20
Starting current [A]	<60	<60	<60	<60
Power factor cos ϕ	> 0.55	> 0.6	> 0.6	> 0.6
Power loss [W] ⁴⁾	min. 20 / max. 150	min. 20 / max. 140	min. 20 / max. 380 ⁵⁾	min. 40 / max. 430
Mains buffering [ms]	<5	<3	<3	<3
Interference resistance corresponding to EN 61800-3	2. Environment			
Overvoltage category ⁶⁾	3	3	3	3
Leakage currents [mA] ⁷⁾	<30	<30	<30	<30
Fuse, external [A] ⁶⁾	10 (15 ²⁾) B charac.	10 B charac.	10 B charac.	25 B charac.
for UL508c	Class CC	Class CC	Class CC	class CC

1) Can only be used with earthed systems. Maximum voltage to earth must not exceed 300 V_{AC}. Maximum possible short-circuit current must not exceed 5000 A.

2) for controllers with 115 V mains voltage. See name plate.

3) A mains reactor is required for continuous loads (time constant 2 min.) with a shaft output of more than 50% of the specified power class. Maximum possible short-circuit current must not exceed 5000 A.

4) The power loss depends on several factors: motor speed, current, cable length, torque and use of the internal ballast resistor.

5) For units with revision status <RS20: min.20 / max. 265

6) Note the constraints for operation corresponding to UL

7) The leakage currents are measured with an RC circuit in accordance with IEC60990. The value can be higher if measured directly. Notes on using ground leakage circuit-breakers on request.

Motor connection

	TLxx32	TLxx34	TLxx36	TLxx38
Power class ^{1) 2)} [kW] at 115V _{AC} (variant) at 230V _{AC} at 400V _{AC} or 480V _{AC}	0.5 0.75 -	- 0.75 1.5	- 1.5 3	- 4 8
Switching frequency [kHz]/ switchable to [kHz]	8 / 16	8 / 16	8 / 16	4 / 8
Nominal current [Arms], r.m.s. value ³⁾	3	3	6	16
Rated current [Apk], amplitude	4.24	4.24	8.48	22.63

	TLxx32	TLxx34	TLxx36	TLxx38
Rated current [Apk], maximum value at lower switching frequency for max. 5 s during motor motion	11.31 even at motor standstill (8.48 ⁴⁾)	11.31 even at motor standstill (8.48 ⁴⁾)	28.28 (16.96 ⁴⁾)	45.26
Maximum value [Apk], amplitude value at higher switching frequency for max. 5 s during motor movement ⁵⁾	8.48	5.66	18.85 (11.31 ⁴⁾)	38.18
Max. speed [rpm]	12,000	12,000	12,000	12,000
Cable length ⁶⁾ [m]	20	20	20	20

- 1) Max. shaft output when using a typical motor, with nominal current and 230 V (TLCx32 only) or 400 V (TLCx34-TLCx38) mains voltage
- 2) At continuous load (time constant 2 min.) with a shaft output greater than 50% of the specified power class a mains reactor is required
- 3) Continuous operation at max. ambient temperature
- 4) For units with a revision status <RS20 (see name plate)
- 5) Values with nominal current and 230 V (TLCx32 only) or 400 V (TLCx34-TLCx38) mains voltage
- 6) Longer motor cable lengths on request

*Internal ballast circuit
IP20 controller*

	TLxx32	TLxx34	TLxx36	TLxx38
Continuous power [W] ¹⁾	60 (30 ²⁾)	100 (50 ²⁾)	200 (80 ²⁾)	80
Max. energy per braking [Ws]	350 (50 ²⁾)	600 (80 ²⁾)	100 (130 ²⁾)	130

- 1) at maximum ambient temperatures and higher power amplifier output the temperature cutout may be triggered
- 2) On units with a revision status <RS20 (see name plate)

*Internal ballast circuit
IP54 controller*

Fan	Ambient temperature [°C]	Continuous power [W]	
		TLCx32	TLCx34
yes	25	170	255
	35	127	190
	45	85	127
no	25	60	90
	35	42	63
	45	25	37

All specifications apply for a surface temperature of 70°C on the ballast heat sink.

24 V_{DC} power supply

Input protection	reverse-polarity-protected
Voltage range	20 V to 30 V
Ripple	2 V _{SS}
Input current (without loading the outputs)	< 1 A
Maximum terminal current	8 A

Signal interface

digital signal inputs	reverse-polarity-protected, no electrical isolation, debounced, debounce interval 0.7 to 1.5 ms
DC voltage U_{high}	12 V to 30 V ($I \geq 3$ mA)
DC voltage U_{low}	≤ 5 V ($I \leq 0.5$ mA)
digital signal outputs	inductively chargeable (150 mH/11 W), short-circuit resistant
DC voltage	≤ 30 V
Switching current	≤ 400 mA
Voltage drop at 400 mA	≤ 1 V
Analogue signal input	
Voltage range	+10 V to -10 V
Input resistance	5 k Ω
Resolution	10 Bit

UL 508C approval

The limit values for the UL 508C approval can be found on page 3-10.

3.3.2 Modules*Encoder module RS422-C*

Signal inputs (A, B, I)	RS422-compatible, electrically connected to 24V GND
Input frequency	≤ 400 kHz, 1 600 000 Inc/s
Output	
Encoder power supply (SENSE)	5 V \pm 5%, max. 300 mA, sense-controlled, short circuit and overload-proof

Pulse/direction module PULSE-C

Signal inputs	
symmetrical	RS422-voltage-compatible
asymmetrical	4.5 V to 30 V, electrically connected to 24 V GND
Input resistance	5 k Ω
Input frequencies: Increment frequency (PULSE/PV, DIR/PR)	≤ 200 kHz
Signal outputs	Open collector outputs, short-circuit resistant
Output voltage	≤ 30 V
Output current, maximum	≤ 50 mA

IOM-C analogue module

digital signal inputs	reverse-polarity-protected, no electrical isolation, debounced, debounce interval 0.7 ms to 1.5 ms
DC voltage U_{high}	12 V to 30 V ($I \geq 3$ mA)
DC voltage U_{low}	≤ 5 V ($I \leq 0.5$ mA)
Current at 24 V	≤ 7 mA
digital signal outputs	inductively chargeable (50 mH), short-circuit resistant, reverse-polarity-protected
DC voltage	12 V to 30 V
Blocking current	≤ 100 μ A
Voltage drop at 50 mA	≤ 2 V
Analogue signal inputs	
Voltage range	+10 V to -10 V
Input resistance	50 k Ω
Resolution	10 Bit
Analogue signal outputs	short-circuit resistant, reverse-polarity-protected
Voltage range	+10 V to -10 V
Output current	max. 5 mA
Resolution	12 bit, ≥ 3800 steps

Hiperface module HIFA-C

Supply voltage, output for encoder	+10 V / 150 mA, short circuit and overload resistant, not secure against noise voltage
Signal inputs	
sine/cosine (SIN, COS)	1 V_{SS} with 2.5 V offset, 0.5 V_{SS} at 100 kHz
Input resistance	2 x1 k Ω to GND
Monitoring of motor temperature (T_MOT)	NTC / PTC
RS485	asynchronous, half-duplex

RESO-C resolver module

Excitation voltage output	3.5 Vrms $\pm 10\%$, max. 60 mA, short circuit and overload resistant, not secure against noise voltage
Excitation frequencies	3.5, 5, 6.5, 10 kHz $\pm 20\%$, programmable with parameters

0098 441 113 110, V1.00, 07.2004

	Monitoring of motor temperature (T_MOT)	NTC / PTC
	Sine/cosine inputs	symmetrical to earth
	Input resistance	2.15 k Ω
	Input voltage	1.75 V _{rms} \pm 10%
<i>Encoder simulation module ESIM3-C</i>	Signal outputs (A,B)	RS422 voltage-compatible, electrically connected to 24V GND
<i>SAM-C safety module</i>	Technical values	See the separate SAM documentation for the technical values.
<i>PBDP-C module</i>	Signal inputs/outputs	corresponding to RS485 standard, electrically isolated
	Transfer rate	\leq 12Mbaud
<i>CAN-C module</i>	Signal inputs/outputs	Level in accordance with ISO 11898, electrically isolated
	Transfer rate	\leq 1M Baud
<i>RS485-C module</i>	Signal inputs/outputs	corresponding to RS485 standard, electrically isolated, 4-wire interface
	Transfer rates	1200, 2400, 4800, 9600, 19200, 38400 baud
<i>MODB-C module</i>	Signal inputs/outputs	corresponding to RS485 standard, electrically isolated, 2/4-wire interface
	Transfer rates	1200, 2400, 4800, 9600, 19200 baud
<i>IBS-C module</i>	Signal inputs/outputs	corresponding to INTER- BUS specification, type 1, two-wire remote bus
	Transfer rate	500 kbaud

In units with the IBS-C module 0V DC is internally permanently connected to PE.

3.3.3 UL 508C approval

The controller is UL 508C-approved with the following data.

Overvoltage category

Input mains overvoltage category III (UL840): The Twin Line product range has been designed in accordance with standard UL840. A UL-approved transient voltage surge suppressor, conforming to UL 1449, with a maximum clamping voltage of 4 kV, shall be provided in all phases of the mains connection of the drive in the end installation. Use a square D SDSA3650 surge arrester or equivalent. This is not required for the TLxx32 ≥ RS20 and TLxx34 ≥ RS20 units.

Fuses

Branch circuit fuse class CC 600V according to UL248 required

Temperature of ambient air

Max. surrounding air temperature 50 °C

Mains connection IP20 controller

	TLxx32	TLxx34	TLxx36	TLxx38
Mains voltage [V]	230 (115 ¹⁾)	480	480	480
Mains frequency [Hz]	47-63	47-63	47-63	47-63
Current consumption [A]	6 (10 ¹⁾)	3.2 ²⁾	5.5 ³⁾	10 ⁴⁾
Phases	1	3	3	3

- 1) for controllers with 115 V mains voltage. See name plate.
- 2) Power class limited to 1200 W on 480 V and 600 W on 230 V
- 3) Power class limited to 2200 W on 480 V and 1100 W on 230 V
- 4) Power class limited to 4000 W on 480 V and 2000 W on 230 V

Mains connection IP54 controller

	TLxx32	TLxx34
Mains voltage [V]	230 (115 ¹⁾)	480
Mains frequency [Hz]	47-63	47-63
Current consumption [A]	6 (10 ¹⁾)	2.4 ²⁾
Phases	1	3

- 1) for controllers with 115 V mains voltage. See name plate.
- 2) Power class limited to 900 W on 480 V and 450 W on 230 V

Motor data

	TLxx32	TLxx34	TLxx36	TLxx38
Motor voltage [V]	0-230	0-480	0-480	0-480
Motor frequency [Hz]	0-400	0-400	0-400	0-400
Motor current [A]	3	3	6	16
Phases	3	3	3	3

Accessories

- Ballast resistor controller, TLBRC connection 600 V_{DC}
- Holding brake controller, TLHBC supply voltage 24 V

Wiring

Use copper wiring resistant to at least 60°C or 75°C.

3.3.4 Accessories

TLHBC holding brake controller

Supply voltage, input	20 V to 30 V
Input current	Input current = 0.5 A + braking current
Output, brake	
DC voltage	20 V to 30 V
Current at 24 V for 100 ms	0.5 A to 2.5 A
Continuous current	0.5 A to 1.25 A
DC voltage with voltage reduction	9.5 V to 15 V
Current at 12 V	0.5 A to 2 A

Safe electrical isolation between 24V input, control input and brake output

Ballast resistor controller TLBRC

Local power supply via DC bus connection	
Switch-on threshold, selectable	
with TLxx32	420 V
with TLxx34, TLxx36 and TLxx38	760 V

Mains reactor

Controller	Mains reactor ^{1) 2)}	Values
TLxx32	RL01201	1.25 mH, 12 A, 600 V, 3 windings
TLxx34	RL00803	5.00 mH, 8 A, 600 V, 3 windings
TLxx36	RL01202	2.50 mH, 12 A, 600 V, 3 windings
TLxx38	RL02502	1.20 mH, 25 A, 600 V, 3 windings

1) Supplier: MTE Corporation, Menomonee Falls, WI. See www.mtecorp.com for additional data and information

2) These reactors have an open design. For the model with case change the next to last number of the part number from 0 to 1.

Motor and encoder cable

The motor cable and encoder cable are suitable for trailing and are available in various lengths. Different cross sections are also possible for the motor cable. See the Accessories chapter for the appropriate type.

Permissible voltage	600 VAC (UL and CSA)
Shield	Shield braiding
Sheath	Oil-resistant PUR
Temperature range	-40°C to +90°C (fixed) -20°C to +80°C (moving)
Minimum bending radius	10 x diameter (fixed) 10 x diameter (moving)

4 Installation



WARNING!

Danger of injury and damage to system components by loss of control!

- The system manufacturer must consider the possible errors that could occur with the signals and in particular the critical functions to ensure a safe status during and after errors. Critical functions include emergency stop and limiting end positions. Observe the accident prevention regulations.
- Consideration of possible errors must include unexpected delay and failure of signals or functions.
- Separate redundant controller paths must be provided for critical functions.

4.1 Electromagnetic compatibility, EMC



WARNING!

Interference with signals and devices may cause injury

Distorted signals can cause unexpected device responses.

- Install the wiring in accordance with the EMC requirements.
- Check compliance with the EMC requirements, particularly in an environment subject to strong interference.

The drive system and the installation are subject to electromagnetic interference. If suitable precautions are not taken, the interference will affect the signals from the control wiring and system parts and adversely affect the operating safety of the system.

This drive system meets the EMC requirements for the second environment under the IEC 61800-3 standard if the measures described for the installation are taken into account. When operating outside this application area note the following:



WARNING!

This is a product with restricted availability under IEC 61800-3. This product may cause interference in living areas; in this case the operator may be required to take appropriate action.

Motor leads and encoder cables are especially critical signal circuits. Use the cables recommended by your local representative. They are tested for EMC safety. These cables can also be used as trailing cables.

Information on the cables can be found on page 10-1

Control cabinet setup

EMC measures	Effect
Use galvanised or chrome-plated mounting plates, make large contact surface connections for metal parts, remove paint from contact surfaces	Good conductivity due to two-dimensional contacts
Ground the control cabinet, door and mounting plate with metal tapes or cables with a cross section area greater than 10 mm ² (8 AWG)	Reduction of emissions.
Fit switching devices such as contactors, relays or solenoids with interference suppressors or spark suppressors (e.g. diodes, varistors, RC elements)	Reduction of mutual interference
Install power and control components separately.	Reduction of mutual interference

Cabling

EMC measures	Effect
Keep wiring as short as possible. Do not install "safety loops", short cables from the star point in the switch cabinet to outlying earth connection.	Avoidance of capacitive and inductive interference injection
Use cable clamps to connect a large surface area of the shield of all shielded cables to the mounting plate at the control cabinet entry.	Reduction of emissions.
Field bus lines and signal lines must not be laid in the same conduit with lines for DC and AC voltage over 60 V. (Field bus lines can be laid in the same conduit with signal and analogue lines)	Prevention of mutual interference
Recommendation: lay in separate conduits at least 20 cm apart.	
Connect large surface areas of cable shields, use cable clamps and tapes	Reduction of emissions.
Earth shields on digital signal lines over a wide area at both ends or via conductive plug housing.	Preventing interference on control cables, reduction of emissions
Use bonding conductors in system with – wide-area installation – different voltage infeed – networking between different buildings	Protection of wiring, reduction of emissions.
Use fine-core bonding conductors	Deflect even high-frequency interference currents
Shield analogue signal lines at one end only at the power controller, at the other end via capacitor, e.g. 10 nF/100V MKT	Preventing ripple loops due to low-frequency interference
Use only shielded motor cables with copper braiding and at least 85% covering, ground a large surface area of the shield at each end.	Controlled discharge of interference currents, reduction of emissions
If motor and machine are not conductively connected, e.g. by an insulated flange or a non-flat connection, earth the motor with an earth wire >10 mm ² (>6 AWG) or ground strap.	Reduction of emissions, increase in resistance to interference
Lay connections of the 24 Vdc supply voltage as "twisted pair".	Preventing interference on control cables, reduction of emissions
Use shielded cables for the signal lines with IP54 controllers.	Reduction of EMC emissions

Power supply

EMC measures	Effect
Operate drive system only on a system with an earthed star point. Do not operate on systems with earthed phase or on a non-earthed system (IT system).	Line filter is only effective on system with an earthed star point.
Connect the negative output of the 24V power supply to PE.	Reduction of EMC emissions, safety
Circuit breaker if there is danger of overvoltage or lightning strike	Protection against damage by overvoltage

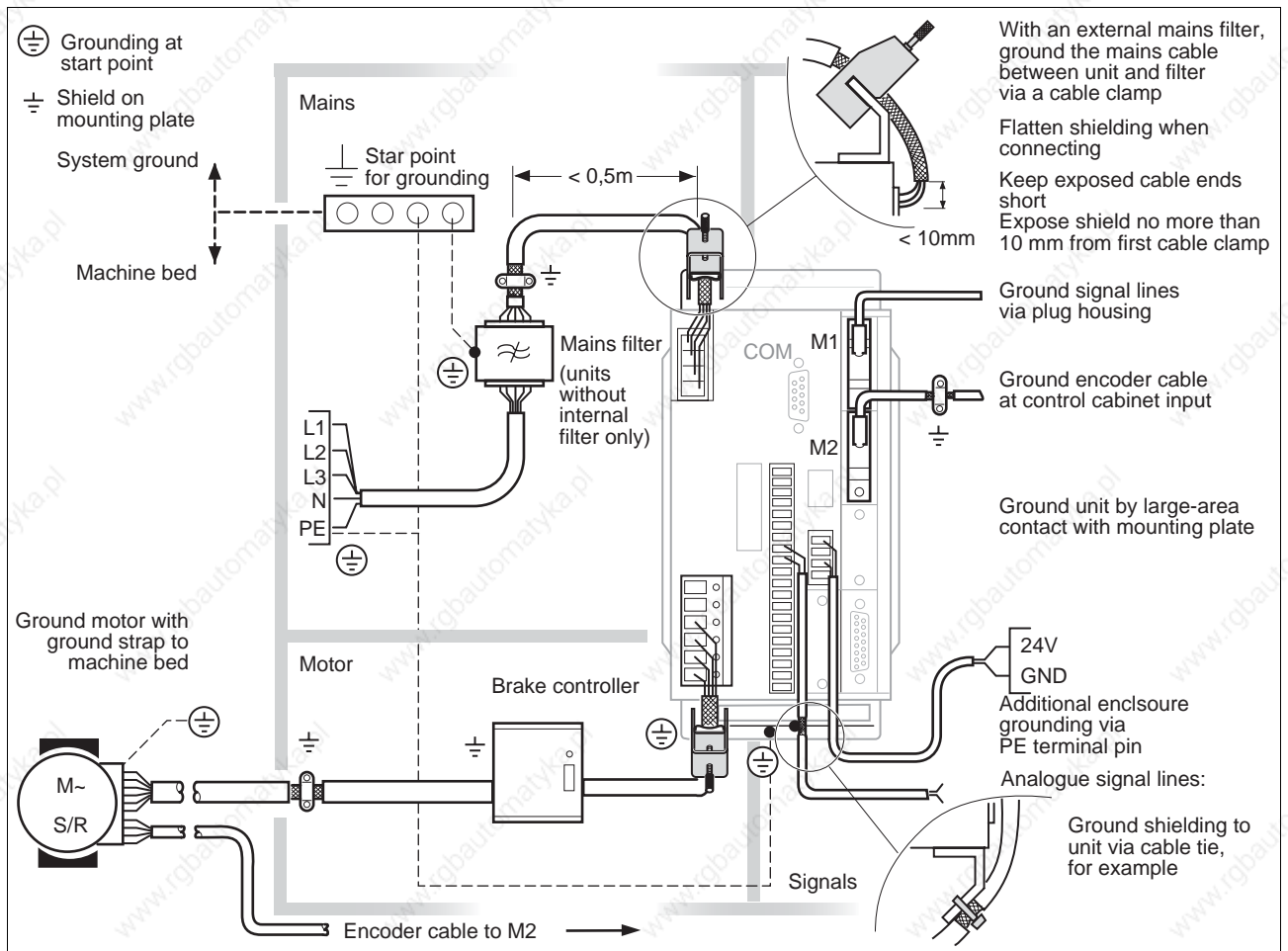

Figure 4.1 EMC measures and subdivisions of the control cabinet

4.2 System components

To connect the controller system components in addition to the system components supplied with the controller are required:

- Synchronous servomotor
- Motor cable
- Cable to motor encoder
- Signal cable corresponding to the interfaces in use
- line cable and line fuses
- Ballast resistor and ballast resistor controller (if required)
- Holding brake controller (if required)
- External power supply, 24 V_{DC} with safe separation - PELV
- external line filter for units with no built-in line filter
- Additional filter and reactors for mains and motor connection depending on system layout
- control cabinet
- NC control or PLC for automatic operation
- PC or Laptop from Windows 98SE and connector cable for commissioning with the commissioning software.

4.3 Mechanical installation



DANGER!

Electric shock from foreign bodies or damage.

Conductive foreign bodies in the product or serious damage can cause accidental energisation.

- Do not use damaged products.
- Prevent foreign bodies such as chips, screws or wire clippings from entering the product.
- Do not use products that contain foreign bodies.

4.3.1 Installing IP20 controller

control cabinet The control cabinet must be dimensioned so that the controller and accessories such as ballast resistor and holding brake controller can be mounted in place and wired to meet EMC standards.

The control cabinet ventilation must be sufficient to dissipate the heat generated by the unit and its components and the heat output of the ballast resistors.

Installation clearances The unit is fitted with a built-in fan. Ventilation slots on and under the unit must be kept at least 70 mm away from neighbouring units or walls.

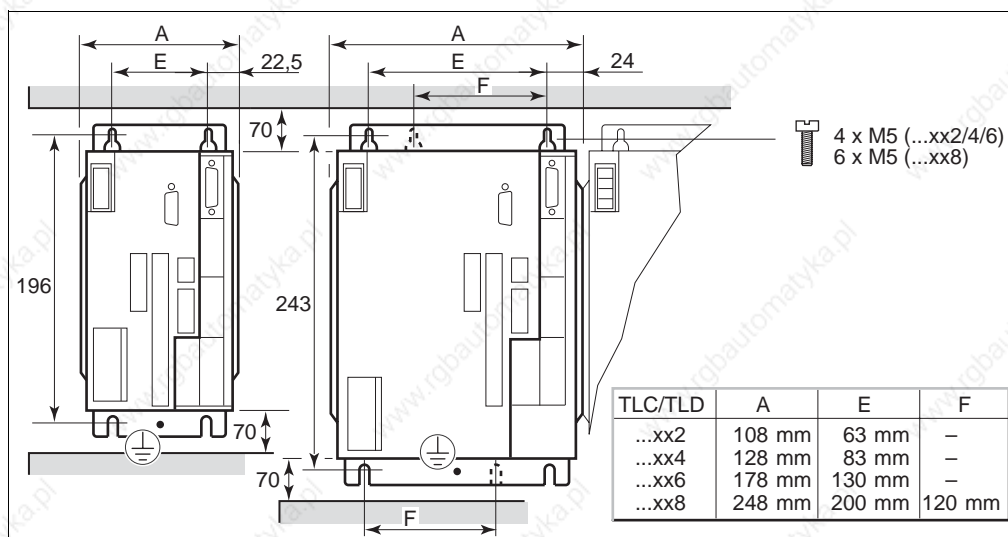

Figure 4.2 Installation clearances, dimensions in mm

- ▶ Position the unit in the switch cabinet so the heat airstrip of other devices, such as an external ballast resistor, does not overheat the cooling air for the unit.
- ▶ Install the unit vertically with the mains connection at the top.
- ▶ Fasten the unit to a galvanised metal plate. The back panel of the units must have a good contact to the metal plate over its entire area.



Painted surfaces have an insulating effect. Remove the paint from the attachment points over a wide area (bright metal) before attaching the unit to a painted mounting plate.

4.3.2 Installing IP54 controller

Installation clearances The IP54 controller must be installed at a minimum distance of 10 mm to adjacent units.

The connections are at the bottom of the case. There must be 20 cm space under the unit to ensure that the connections are not kinked.

There is a ventilation element on the bottom of the unit. Do not remove the protective cover!

The unit must be mounted vertically for protection against water.

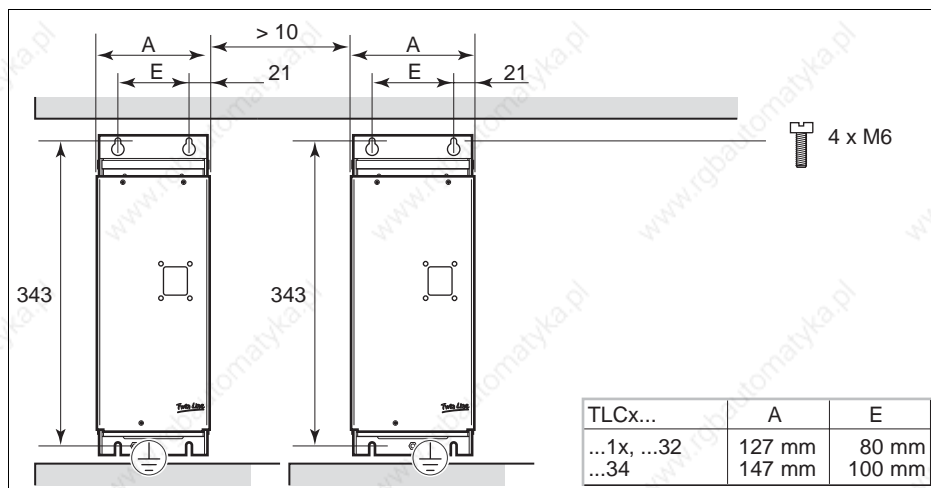

Figure 4.3 Installation clearances, dimensions in mm

4.3.3 Attaching labels

Unit label The unit label shows information on the meaning of all operating states – displayed by the 7-segment display – and the assignment of the signal interface. There is a copy template of the unit label in this chapter.

- IP20 controller**
- ▶ Attach the unit label to the terminal side of the signal plug from the inside into the unit cover of the Twin Line unit.
 - ▶ After the electrical installation and replacement of the unit cover, the cables for the mains connection and the two top signal terminals are led out of the top of the cover, and the CABLE and remaining signal cables to the bottom.

- IP54 controller**
- ▶ Attach the label to the side of the Twin Line unit.

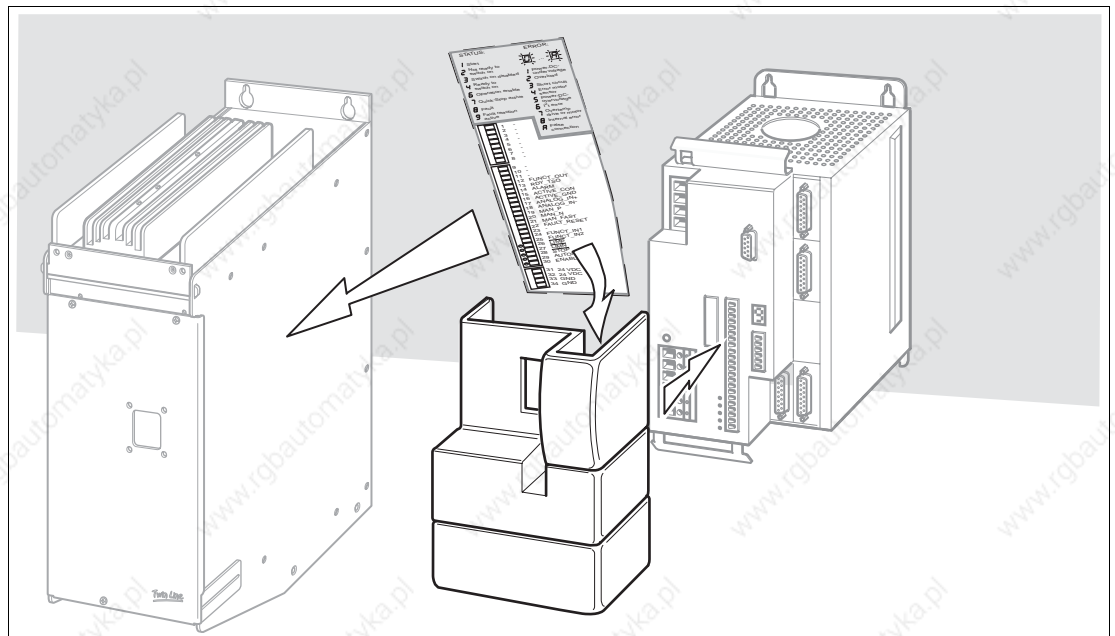

Figure 4.4 Unit label

Template

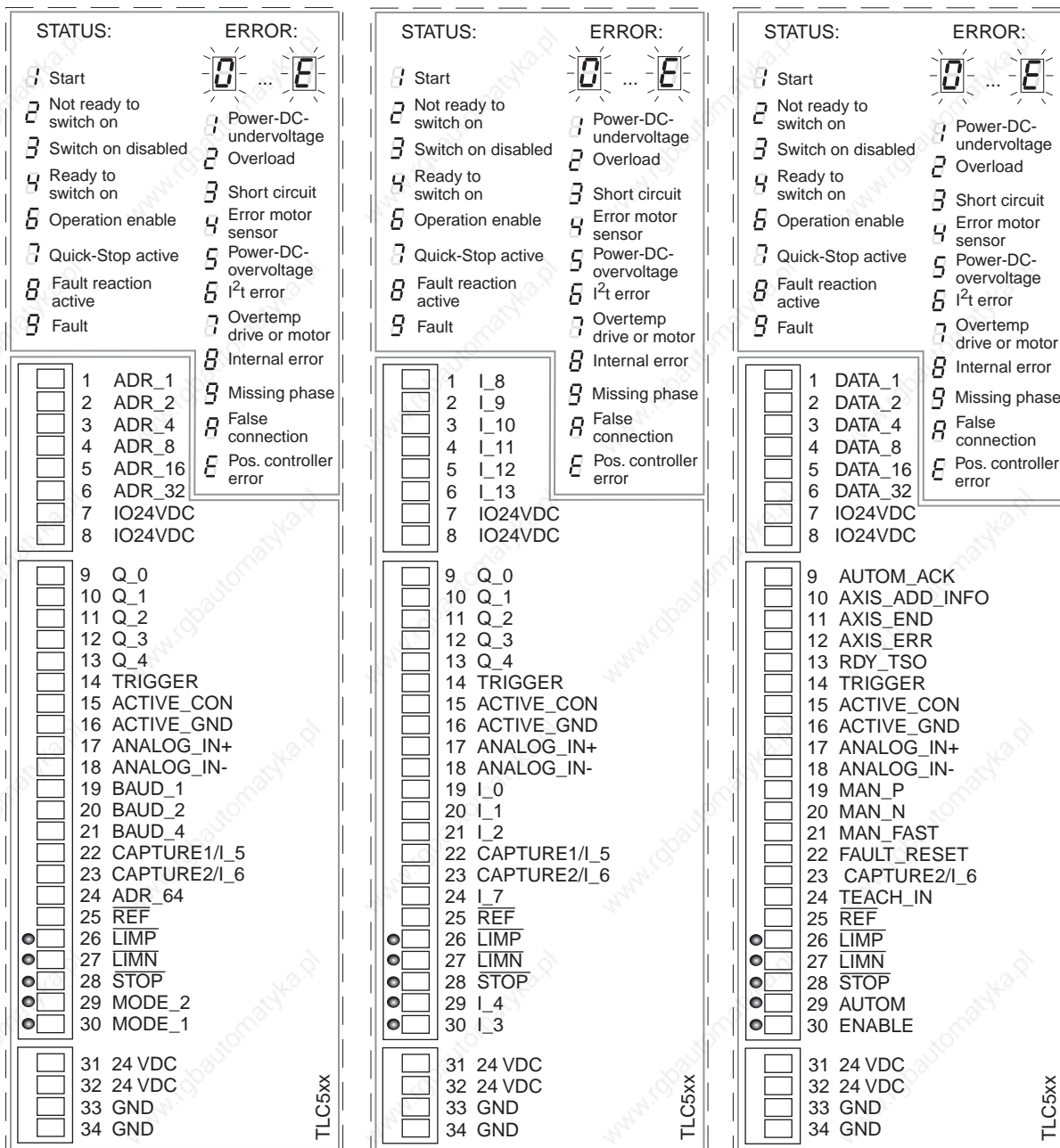

Figure 4.5 Unit label

4.3.4 Installing accessory components of the IP20 controller

External mains filter The position controller is supplied with a built-in mains filter as standard. A special version of the unit can also be ordered without a mains filter.

When using a unit without an integrated mains filter an external mains filter is required. The user must ensure that the EMC directives are observed in this case.

Use units with external mains filters only if it is possible to test the function and EMC of the selected mains filter with instruments at the unit itself.

The type code on the unit indicates whether or not a mains filter is integrated.

Select a two-stage mains filter, e.g. for a frequency converter. The size and selection of a suitable filter is for the system designer to decide.

- ▶ Fit the mains filter near the mains connection and on the same mounting plate. The cable length to the controller must not be longer than 50 cm. **The cable must be shielded and the shield must be earthed at both ends.**

Mains reactor A mains reactor is required for continuous loads (time constant 2 min.) with a shaft output of more than 50% of the specified power class. For more information see page 3-11

Holding brake controller See page 4-62

Ballast resistor

- The approved ballast resistors comply with degree of protection IP65. They can be installed outside the control cabinet in an environment with this degree of protection.
- The ballast resistors are supplied with a 90° mounting bracket.
- For connection to the TLBRC ballast resistor controller a 3-core, temperature-resistant cable with a length of 0.75 m is permanently installed. **The cable must be shielded and the shield must be earthed at both ends.**



WARNING!

Hot surfaces can cause burns, fire and damage to system components.

The ballast resistor temperature can exceed 250°C in some conditions.

- Prevent contact with the hot ballast resistor.
- Do not place flammable or heat-sensitive components in the immediate vicinity of the ballast resistor.
- Ensure good heat dissipation.
- Check the temperature of the ballast resistor by conducting a test run under the most critical conditions.

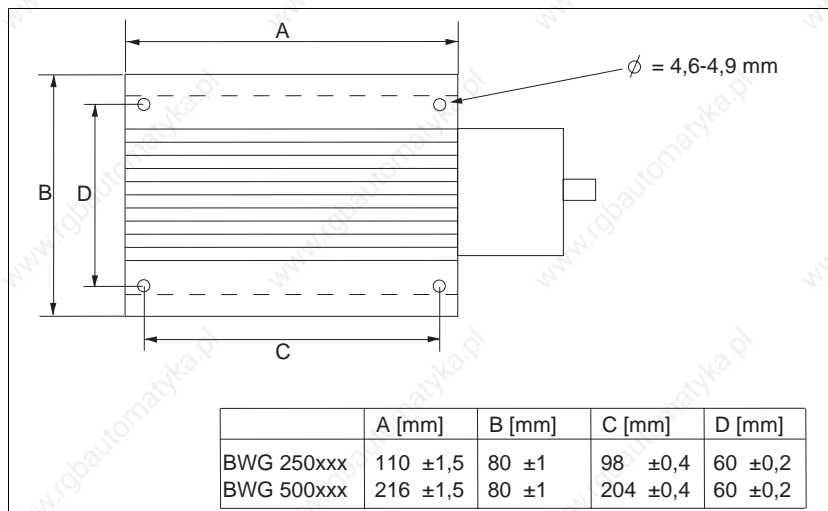

Figure 4.6 Size and installation dimensions of the ballast resistor in the versions with 100W and 200W continuous power

4.3.5 Installing accessory components of the IP54 controller

Terminal angle The IP54 controller includes a terminal angle as an optional accessory for additional wiring.

- ▶ Open the front plate with the three mounting screws.
- ▶ Fix the terminal angle to the top left-hand side of the top of the housing, using two M3 screws.
- ▶ Close the front panel with the three screws.

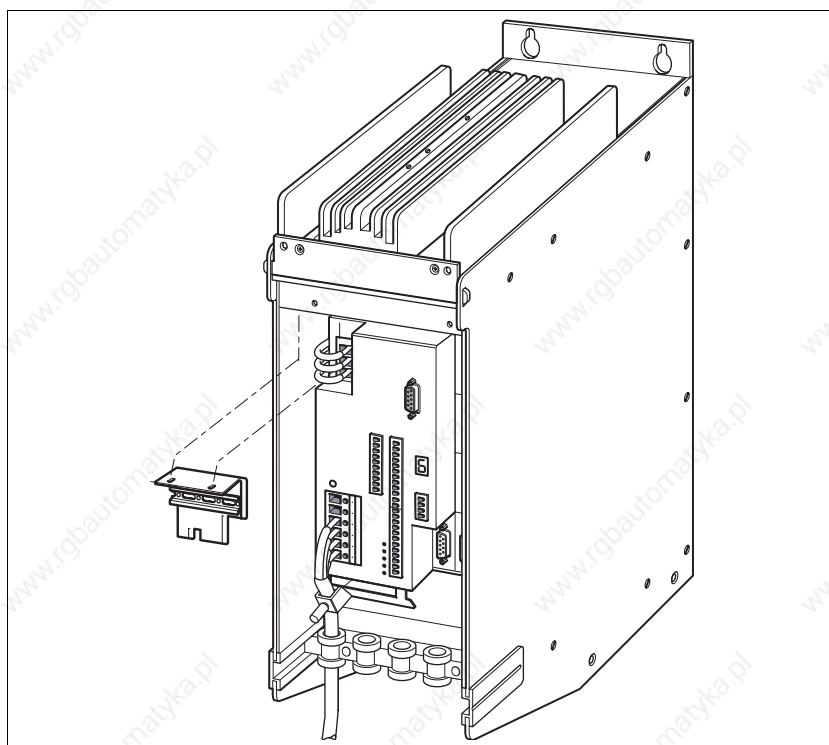

Figure 4.7 Connecting the terminal angle

4.4 Electrical installation



DANGER!

Electric shock, fire or explosion

- Only qualified personnel who are familiar with and understand the contents of this manual and the other relevant manuals are authorised to work on and with this drive system.
- Before working on the drive system:
 - Switch off power to all terminals.
 - Place a sign "DO NOT SWITCH ON" on the switch and lock to prevent switching on.
 - **Wait 6 minutes** (for discharge of DC bus capacitors).
 - Measure voltage between DC+ and DC- and check for <48V. (The DC bus LED is not a safe indication for absence of the DC bus voltage).
- Do not short-circuit DC bus or touch unshielded components or screws of the terminals with voltage present.
- Install all covers and close the housing doors before applying power.
- The motor generates voltage when the shaft is rotated. Lock the shaft of the motor to prevent rotation before starting work on the drive system.
- The system manufacturer is responsible for compliance with all applicable regulations relevant to earthing the drive system.
- Do not reach into the drive system (e.g. no pointed objects).



DANGER!

Electric shock from foreign bodies or damage.

Conductive foreign bodies in the product or serious damage can cause accidental energisation.

- Do not use damaged products.
- Prevent foreign bodies such as chips, screws or wire clippings from entering the product.
- Do not use products that contain foreign bodies.



WARNING!

Interference with signals and devices may cause injury

Distorted signals can cause unexpected device responses.

- Install the wiring in accordance with the EMC requirements.
- Check compliance with the EMC requirements, particularly in an environment subject to strong interference.

**WARNING!**

This product can cause a d.c. current in the protective conductor!

- Where a residual-current-operated protective device (RCD) is used for protection in case of direct or indirect contact, only an RCD of Type B is allowed on the supply side of this product.
- Otherwise, another protective measure shall be applied, such as separation from the environment by double or reinforced insulation, or isolation from the supply system by a transformer.

Cable suitability

Cable must not be twisted, stretched, squeezed or buckled. Use always only cables according the cables specification. Ensure the suitability for:

- Trailing cable
- Temperature range
- Chemical resistance
- Outdoor installation
- Underground installation

4.4.1 Electrical installation of IP54 controller



DANGER!

Electric shock because of insufficient earthing.

These drive systems have increased leakage current > 3.5 mA. A second protective conductor must always be connected.

- Connect a second protective conductor with a minimum cross section in accordance with IEC 60364-5-54 at the separate earth terminal.

In the IP54 controller most of the electrical connections inside the case are connected.

The following connections are made to the underside of the housing:

- Connection for PC or the TLHMI with a 9-pin Sub-D socket
- Mains connection with a circular power plug.

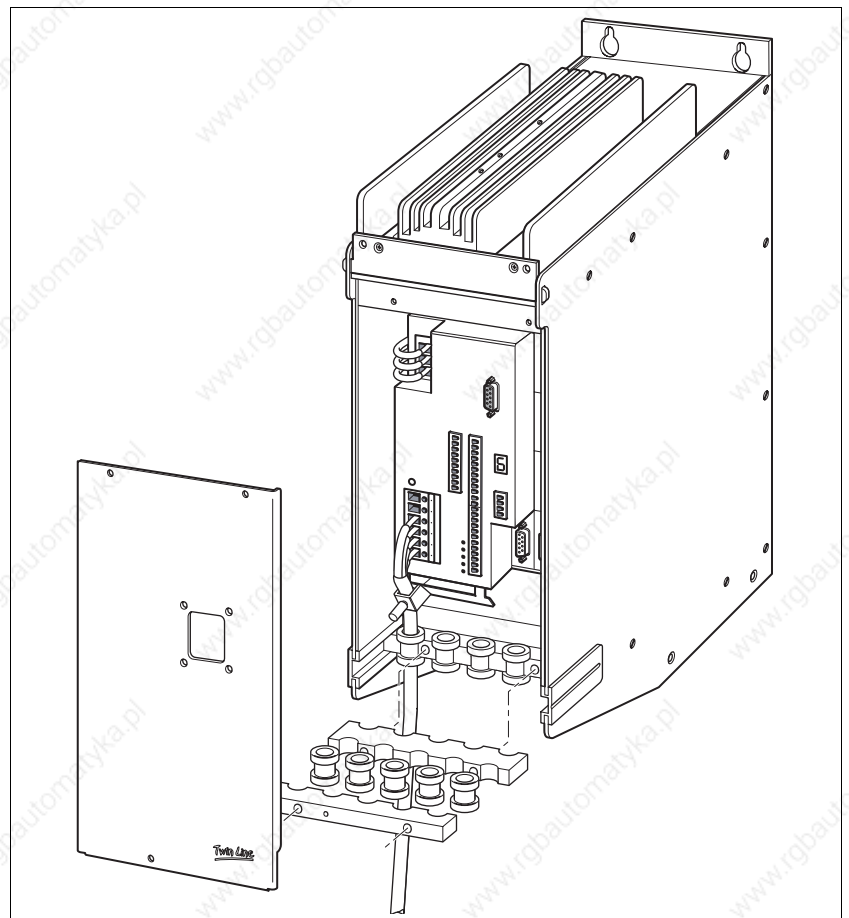

Figure 4.8 Sample connection for the IP54 controller

- ▶ Open the front plate via the three mounting screws.
- ▶ Make the necessary connections to:
 - Motor and position feedback

- Field bus
- signal interface for manual operation

For details of the various connections see the following subsections.

- ▶ Place the grommets on the cables. Only use grommets whose inside diameter matches that of the cables to ensure that they are sealed and not subject to tension.
- ▶ Install the grommets.
- ▶ Ground the unit at the grounding point at the back of the unit near the bottom. Connect them to the system ground and the machine bed.
- ▶ Close the front plate with the three screws.

The holding brake controller can be built into the unit as an option.

The fan and the holding brake controller are already connected to pins 32 and 34.

An additional fan can be installed on the unit to increase the ballast power.

An appropriate fan kit can be found on page 10-1

4.4.2 Mains connection for single-phase units



DANGER!

Electric shock because of insufficient earthing.

These drive systems have increased leakage current > 3.5 mA. A second protective conductor must always be connected.

- Connect a second protective conductor with a minimum cross section in accordance with IEC 60364-5-54 at the separate earth terminal.

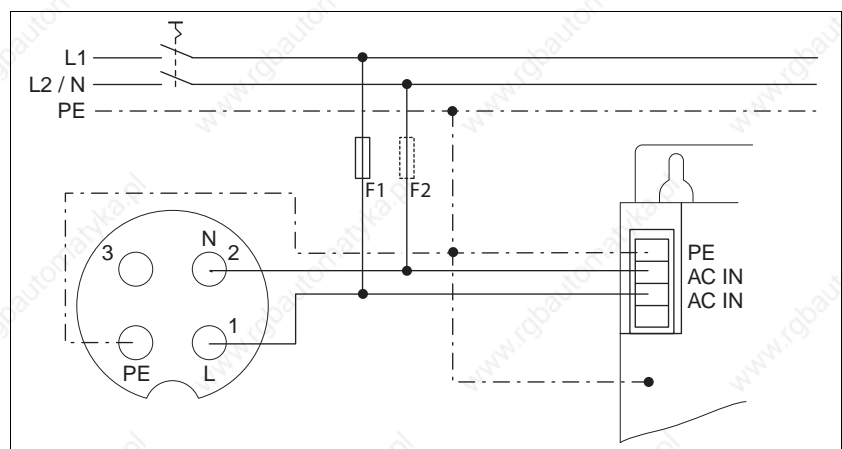

Figure 4.9 Mains connection for IP54 controller (left) and IP20 controller (right)

Both versions

- Connection cross section for power cable is 1.5 to 2.5 mm²
- Fuse system as specified by the Technical Data. See page 3-5
- Install fuse F2 only in case of operating the controller with two phases (L1 and L2).
- The additional PE connection on the case must be connected because of the high leakage currents.
- If necessary, install a line reactor or surge arrester.
- Requirements for installation according UL. See page 3-10

IP20 controller

- ▶ Connect power cables to the AC IN and PE screw terminals on the single-phase unit.
- The correct torque for the terminal screws is 0.4 - 0.5 Nm.
- For controllers without integrated mains filter, any power cable over 200 mm in length must be shielded between the mains filter and the controller and grounded at both ends.
- For units with a hood, the cable must be led upwards from the point of connection.

IP54 controller



CAUTION!

Prior damage or destruction of the drive.

The plugs for the mains connection can be replaced on three-phase and single-phase IP54 units. If a single-phase unit is connected to a three-phase power connection the unit may be damaged or destroyed.

- Label the connections.
 - Check the wiring.
- ▶ Connect the power cable to the power plug using terminals 1, 2 and PE.

Wire end ferrules

When using wire end ferrules note the following:

- Only use square end ferrules to ensure that they do not work loose.
- The wire must fill the wire end ferrule over its entire length. Only then has the connection been made safe to ensure maximum current carrying capacity and vibration resistance.

4.4.3 Mains connection for three-phase units



DANGER!

Electric shock because of insufficient earthing.

These drive systems have increased leakage current > 3.5 mA. A second protective conductor must always be connected.

- Connect a second protective conductor with a minimum cross section in accordance with IEC 60364-5-54 at the separate earth terminal.

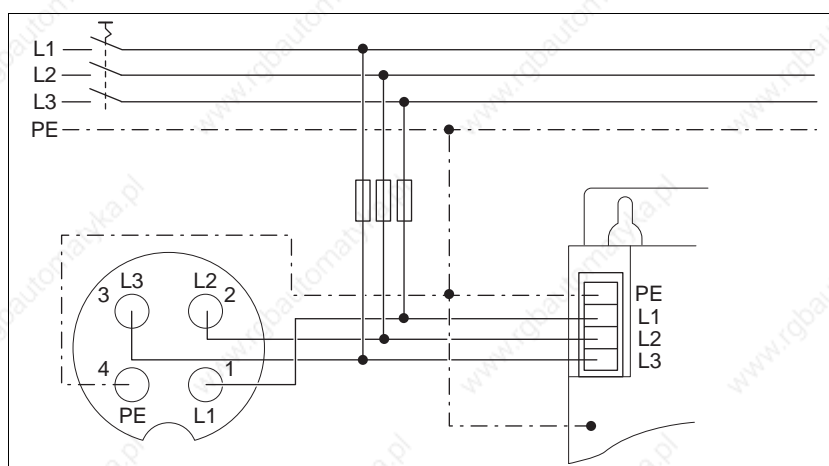

Figure 4.10 Mains connection for IP54 controller (left) and IP20 controller (right)

Both versions

- Three-phase units must be operated in a three-phase system only.
- Connection cross section for power cables corresponding to the following table.

Mains connection	TLxx34	TLxx36	TLxx38
Connection cross-section [mm ²]	1.5 to 4	1.5 to 4	2.5 to 4
Line fuse [A]	10	10	25

- Fuse system as specified by the Technical Data. See page 3-5
- The additional PE connection on the case must be connected because of the high leakage currents.
- If necessary, install a line reactor or surge arrester.
- Requirements for installation according UL. See page 3-10

IP20 controller

- ▶ In the case of three-phase units, connect the power cables to screw terminals PE, L1, L2 and L3.
- The correct torque for the terminal screws is 0.4 - 0.5 Nm.
- For controllers without integrated mains filter, any power cable over 200 mm in length must be shielded between the mains filter and the controller and grounded at both ends.

- For units with a hood, the cable must be led upwards from the point of connection.

Wire end ferrules

When using wire end ferrules note the following:

- Only use square end ferrules to ensure that they do not work loose.
- TLxx32 only: Do not use end ferrules with a plastic collar on wires with a cable cross-section of 2.5 mm² (14 AWG).
- The wire must fill the wire end ferrule over its entire length. Only then has the connection been made safe to ensure maximum current carrying capacity and vibration resistance.

IP54 controller

- ▶ Connect the power cables to screw terminals PE and 1, 2 and 3.

4.4.4 Motor connection on IP20 controller



DANGER!

Electric shock

High voltages can occur unexpectedly at the motor connection.

- The motor generates voltage when the shaft is rotated. Lock the shaft of the motor to prevent rotation before starting work on the drive system.
- AC voltages may jump over unused wires in the motor cable. Isolate unused wires at both ends of the motor cable.
- The system manufacturer is responsible for compliance with all applicable regulations relevant to earthing the drive system. Extend the earth through the motor cable with an additional earth at the motor housing.

Preparing the motor cable

Note the dimensions shown when sizing the motor cable for direct connection to the IP20 controller.

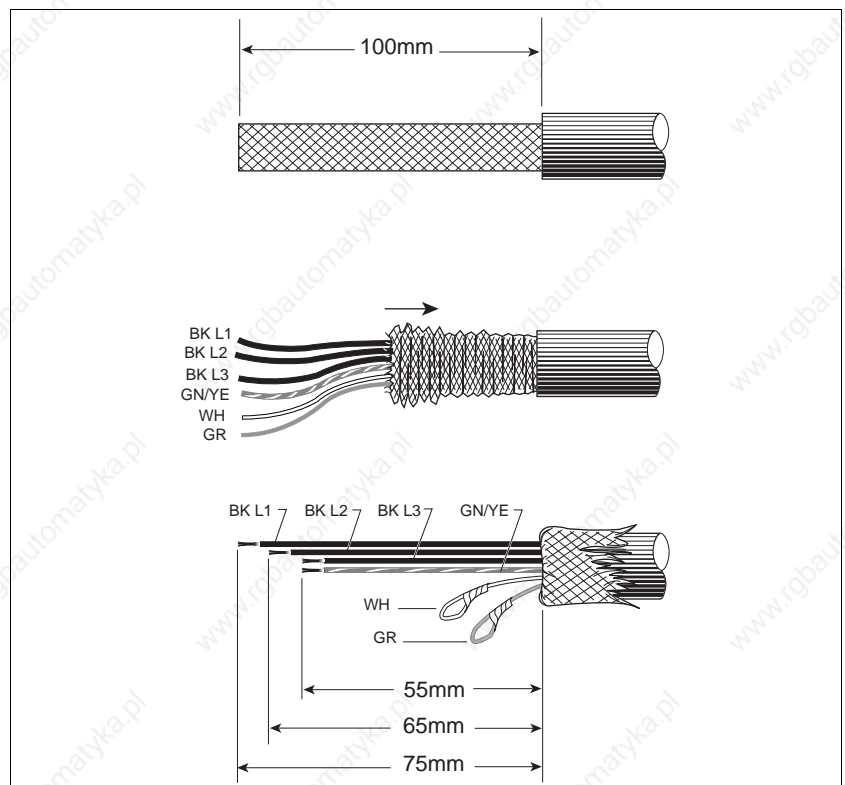

Figure 4.11 Sizing for IP20 controller

Wire end ferrules

When using wire end ferrules note the following:

- Only use square end ferrules to ensure that they do not work loose.
- TLx32 only: Do not use end ferrules with a plastic collar on wires with a cable cross-section of 2.5 mm^2 (14 AWG).
- The wire must fill the wire end ferrule over its entire length. Only then has the connection been made safe to ensure maximum current carrying capacity and vibration resistance.

*EMC requirement:
Motor and sensor system wiring*

The motor wiring and the sensor system wiring for the drive solution are digital signal wires and therefore must be connected with low resistance or over a wide area to the power controller, switch cabinet output and at the motor.

- ▶ Lay both sets of wiring from the power controller to the motor without interruption.
- ▶ If a line has to be interrupted, shielded connections and metal casing must be used to prevent interference.
- ▶ Switching components (e.g. contactors) must not be installed between the power controller and the motor.
- ▶ If possible, the motor cable and signal cables must be laid at a distance of at least 20 cm from each other. If the distance is less than this, the motor cable and signal cables must be separated by grounded screening plates.

Connecting the motor cable



CAUTION!

Destruction of the drive system.

The terminals for the brake from the motor cable must not be directly connected to the controller

- Connect the brake to a holding brake controller only.
- ▶ Connect the motor wires and protective ground to terminals U, V, W and PE. The cable assignment at the motor and unit side must match.

Terminal	Terminal	Colour ¹⁾
U	Motor cable	black L1 (BK)
V	Motor cable	black L2 (BK)
W	Motor cable	black L3 (BK)
PE	Protective conductor	green/yellow (GN/YE)
Shield terminal	Shield	-

1) Colours of older wiring: U = brown (BN), V = blue (BL), W = black (BK), PE = shield filler wire

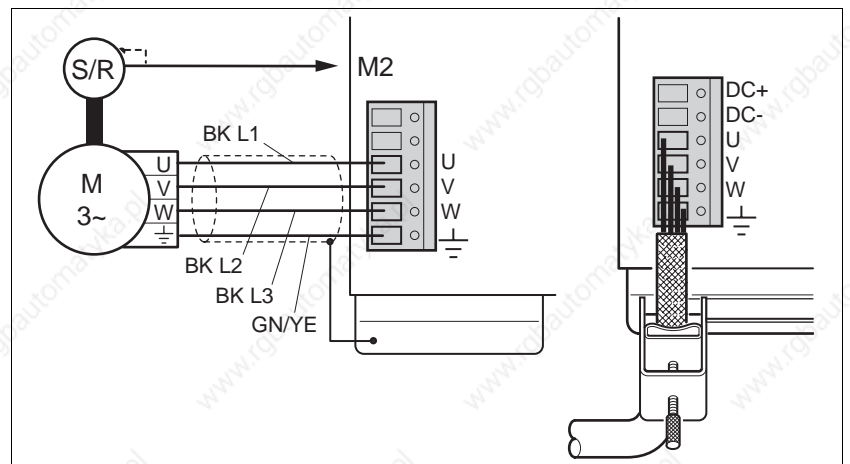

Figure 4.12 Connection of motor cable to controller

	TLxx32	TLxx34	TLxx36	TLxx38
Cable cross section ²⁾	1.5	1.5 to 2.5	1.5 to 2.5	4
Max. cable length ¹⁾ [m]	20	20	20	20
Tightening torque for terminal screws [Nm]	0.4 - 0.5	0.5 - 0.6	0.5 - 0.6	0.5 - 0.6

1) Longer cables can be ordered

- For units with a hood, the cable must be led downwards from the point of connection.

4.4.5 Motor connection IP54 controller



DANGER!

Electric shock

High voltages can occur unexpectedly at the motor connection.

- The motor generates voltage when the shaft is rotated. Lock the shaft of the motor to prevent rotation before starting work on the drive system.
- AC voltages may jump over unused wires in the motor cable. Isolate unused wires at both ends of the motor cable.
- The system manufacturer is responsible for compliance with all applicable regulations relevant to earthing the drive system. Extend the earth through the motor cable with an additional earth at the motor housing.

Preparing the motor cable

Note the dimensions shown when sizing the motor cable for direct connection to the IP54 controller with integrated holding brake controller. If the holding brake controller is not integrated, the dimensions are the same as for the IP20 controller.

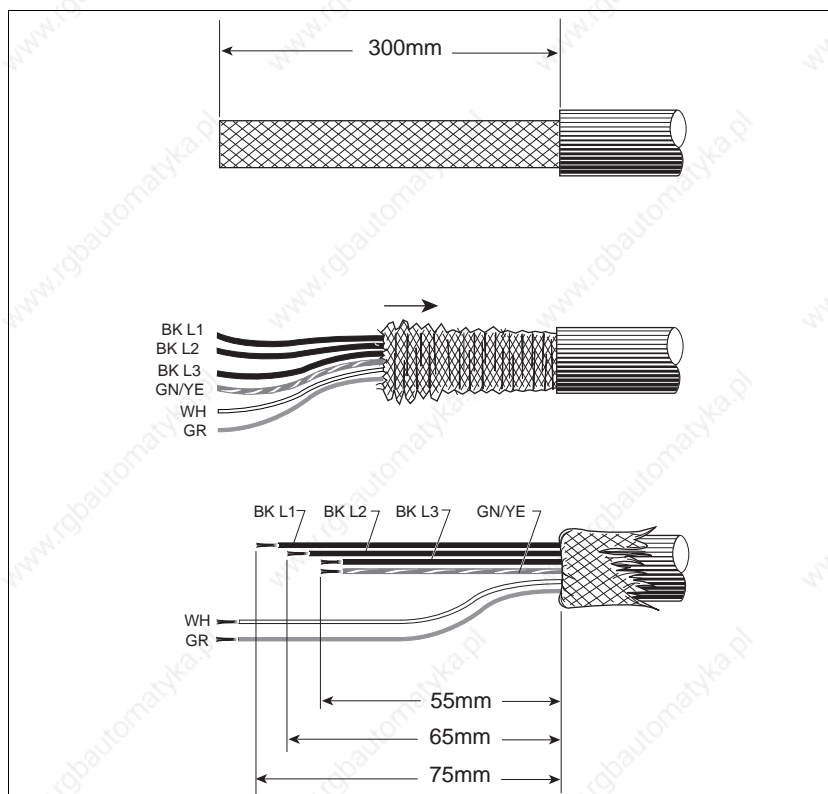

Figure 4.13 Sizing for IP54 controller with integrated holding brake controller

Wire end ferrules

When using wire end ferrules note the following:

- Only use square end ferrules to ensure that they do not work loose.
- TLxx32 only: Do not use end ferrules with a plastic collar on wires with a cable cross-section of 2.5 mm² (14 AWG).

*EMC requirement:
Motor and sensor system wiring*

- The wire must fill the wire end ferrule over its entire length. Only then has the connection been made safe to ensure maximum current carrying capacity and vibration resistance.

The motor wiring and the sensor system wiring for the drive solution are digital signal wires and therefore must be connected with low resistance or over a wide area to the power controller, switch cabinet output and at the motor.

- ▶ Lay both sets of wiring from the power controller to the motor without interruption.
- ▶ If a line has to be interrupted, shielded connections and metal casing must be used to prevent interference.
- ▶ Switching components (e.g. contactors) must not be installed between the power controller and the motor.
- ▶ If possible, the motor cable and signal cables must be laid at a distance of at least 20 cm from each other. If the distance is less than this, the motor cable and signal cables must be separated by grounded screening plates.

Connecting the motor cable

- ▶ Connect motor wires and protective conductor to terminals U, V, W and PE. The cable assignment at the motor and unit side must match.

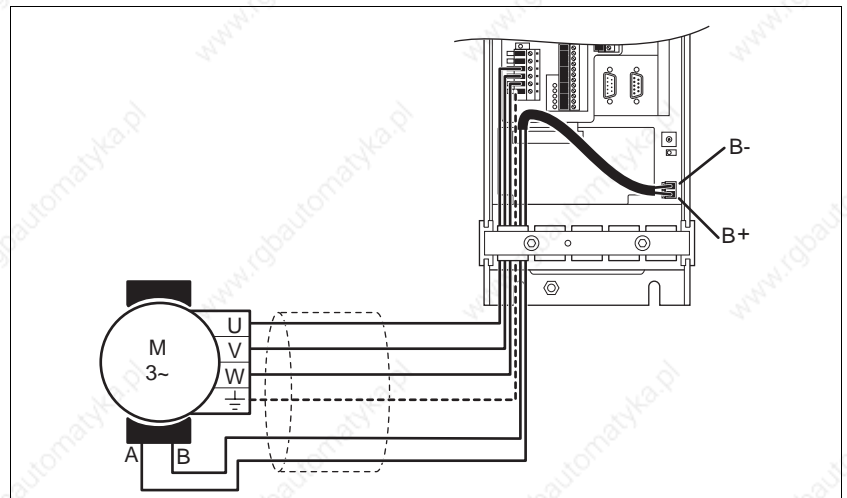

Figure 4.14 Connection of the motor cable and control connections of the holding brake on the unit

Connecting holding brake

The holding brake connection can be built into the unit as an optional extra.

- ▶ Guide the two brake wires through the included insulation sleeve.
- ▶ Connect terminal B+ to White and B- to Grey

The holding brake controller's power requirement depends on the switching current for the holding brake:

$$\text{Brake controller input current [A]} = 0.5 \text{ A} + \text{switching current [A]}$$

- ▶ Set the switch for voltage reduction:

The function of the voltage reduction is described in chapter 7.11 „Braking function with TLHBC“ from page 7-38.

4.4.6 Connection for parallel operation of two units



CAUTION!

Destruction of the drive system by incorrect parallel operation.

Operation with a non-approved parallel circuit on the DC bus may destroy the drive systems immediately or after a delay.

- Never connect the DC bus of more than two drive systems.
- Never connect the DC bus of drive systems of different power classes.
- Never connect the DC bus of drive systems with 115 V rated voltage.
- Never reverse DC+ and DC-.
- If one drive system on the DC bus requires a line reactor, both drive systems must be fitted with a line reactor.
- Use separate fuses for each drive system.
- Operate both drive systems on the same power system (on the same line fuse), and on the same phase on single-phase systems.

Function Two controllers may exchange superfluous braking energy through the DC bus connection. In anticyclic mode in which one motor is accelerated while the other is braked at the same time, some of the energy can be exchanged between the units.

When two units use the same ballast resistor controller, the DC bus connections of both units can be connected in parallel automatically. See page 4-64

Cable specifications

- Shielded wires
- Maximum cable length: 2m
- minimum cross-section: like mains connection
- For example: Motor cable or Belden 7421AS (2 x #16 AWG/1.5 mm²), 7434AS or (2 x #14 AWG/2.5 mm²) or 7443AS (2 x #12 AWG/4mm²) cable or similar.

Terminal

- ▶ Join the DC bus connections of the two units: DC+ to DC+ and DC- to DC-.
- ▶ Earth the shield at both ends with a shielding terminal on the case.

	TLxx32	TLxx34	TLxx36	TLxx38
Tightening torque of the terminal screws [Nm]	0.4 - 0.5	0.5 - 0.6	0.5 - 0.6	0.5 - 0.6

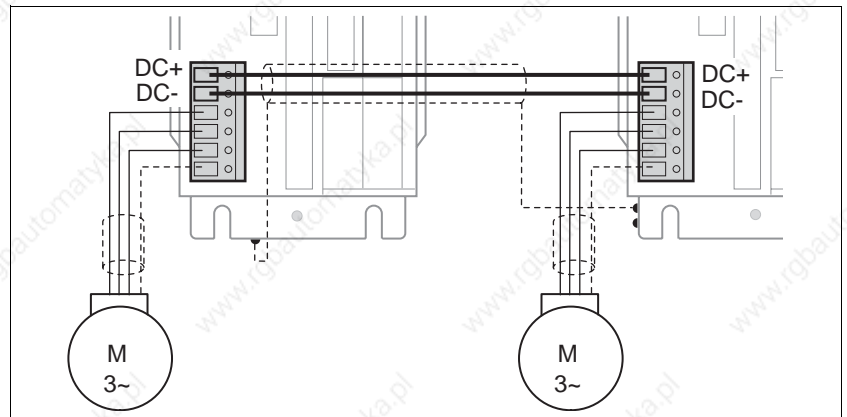

Figure 4.15 Connection for parallel operation with two controllers

For units with a hood, the cable must be led downwards from the point of connection.

EMC measures

The DC bus cable is a source of interference and must be laid out carefully:

- The shield braiding of the cable must be laid out over a wide area on the unit housing. Use the shielding terminals available as accessories for the housing terminal.
- Exposed cable ends may be unshielded for a distance of less than 20 mm only.

4.4.7 Connecting the 24 V supply voltage



DANGER!

Electric shock from incorrect power supply.

The +24VDC supply voltage is connected with many exposed signals in the drive system.

- Use a power supply that meets the requirements for PELV (Protective Extra Low Voltage)
- Connect the negative output of the power supply to PE.
- Do not interrupt the negative connection between power supply and load with a fuse or switch



CAUTION!

Destruction of contacts.

The connection for the DC power supply at the drive system does not have a make current limit. If the DC voltage is switched on by switching contacts, the contacts may be destroyed or welded shut.

- Use a power supply that limits the peak value of the output current to a value permissible for the contact.
- Switch the line input of the power supply instead of the DC output voltage.

- ▶ Run the 24 V power supply wiring from a power supply (PELV) to the unit
- ▶ Earth the negative output at the power supply

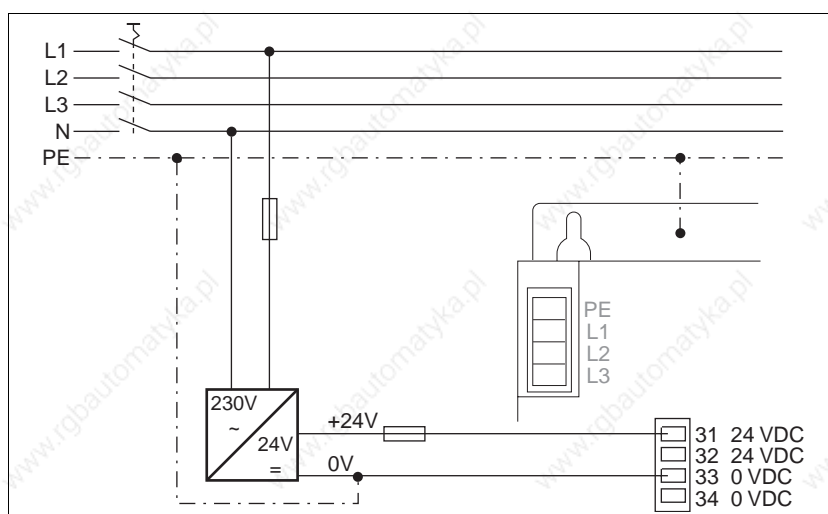

Figure 4.16 24 V connection for single phase and three-phase units

Pin	Signal	active	Meaning	I/O
31, 32	+24VDC	-	24 V _{DC} supply voltage internally connected to pin 32	-

Pin	Signal	active	Meaning	I/O
33, 34	0VDC	-	Reference potential to +24VDC internally connected to pin 34 and pin 16	-

- Pin 32 and 43 can be used as 24 V output for additional consumers or for cascading multiple Twin Line units; the maximum terminal current is 7.5 A.
 - When dimensioning the 24 V power supply take additional consumers such as holding brake, holding brake controller, signal interface and fan into account.
 - For smooth functioning the 24V_{DC} voltage must be earthed.
 - To ensure that the motor retains its position when the power supply of the power amplifier is switched off, the power amplifier must be locked before disconnecting the supply voltage. The external 24 V power supply must remain switched on and no external torque may be exerted on the motor.
 - Lay the 24V supply line at a distance of at least 20 cm from other lines to ensure EMC protection. Make the 0 V and 24 V power supply line into a twisted pair.
 - The torque for terminal screws 1-34 is 0.22 Nm to 0.25 Nm.
- IP54 controllers*
- Fan and holding brake controller are connected to pins 32 and 34.
 - In the IP54 controller a shielded lead-out of the 24 V line and signal lines to the unit is required to retain the emission limit values.

4.4.8 Connection to the signal interface

The controller communicates over the signal interface lines.

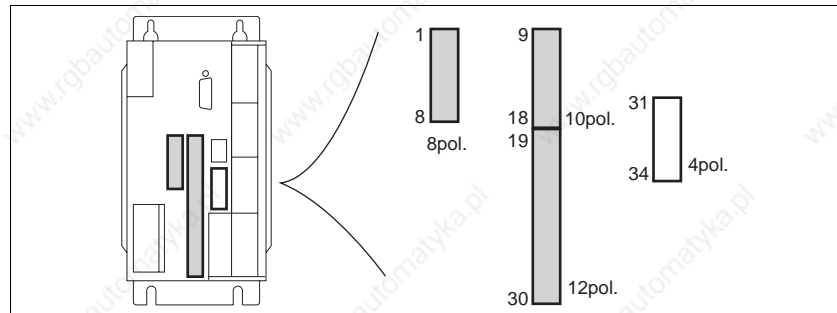

Figure 4.17 Signal interface: 1-30: inputs/outputs, 31-34: 24 V connection

- ▶ Wire the connections of the signal interface depending on the selected operating mode.



CAUTION!

Loss of control over controller.

The use of $\overline{\text{LIMP}}$ and $\overline{\text{LIMN}}$ can offer some protection against dangers (e.g. impact on mechanical stop caused by incorrect motion defaults).

- Use $\overline{\text{LIMP}}$ and $\overline{\text{LIMN}}$ where possible.
 - Check that the external sensors or switches are correctly connected.
 - Check that the external sensors or switches are installed correctly for their function. The braking distance of the drive must not cause damage.
 - The functions must be enabled in the controller software to allow $\overline{\text{LIMP}}$ and $\overline{\text{LIMN}}$ to be used.
 - This function cannot provide protection against faulty functioning within the controller or the sensors.
- ▶ Apply inputs $\overline{\text{LIMP}}$, $\overline{\text{LIMN}}$ and $\overline{\text{STOP}}$ to +24 V voltage when they are not used or switch off with the parameter `Settings.SignEnabl`.
 - ▶ The shield of the analogue signal cable at the inputs must be on the unit side. A capacitor must be connected between shield and earth. (e.g. 10nF/100V MKT)

The connection terminals of the signal interface must be connected only when the unit is without power.

Variable interface connections

The assignment of the signal interface depends on the switching status of the parameter `Settings.IO_mode`.

- `Settings.IO_mode = "0"`: Input signals are used for setting address and baud rate in field-bus mode. The controller reads the address and baud rate setting directly after switching on the 24 V power supply.

- Settings.IO_mode = "1": input signals I_0 to I_13 and output signals Q_0 to Q_4 can be freely set.
- Settings.IO_mode = "2": Input and output signals are permanently assigned.

The following table shows the assignment of interface connections.

Pin	Signal at IO_mode=0/1	Signal at IO_mode=2	active	Meaning	I/O
1	ADR_1 / I_8	DATA_1	high	ADR_1: Bit 0 for the network address Data_1: Bit 0 for selecting a list number	I
2	ADR_2 / I_9	DATA_2	high	ADR_2: Bit 1 for the network address Data_2: Bit 1 for selecting a list number	I
3	ADR_4 / I_10	DATA_4	high	ADR_4: Bit 2 for the network address Data_4: Bit 2 for selecting a list number	I
4	ADR_8 / I_11	DATA_8	high	ADR_8: Bit 3 for the network address Data_8: Bit 3 for selecting a list number	I
5	ADR_16/I_12	DATA_16	high	ADR_16: Bit 4 for the network address Data_16: Bit 4 for selecting a list number	I
6	ADR_32/I_13	DATA_32	high	ADR_32: Bit 5 for the network address Data_32: Bit 5 for selecting a list number	I
7	IO24VDC	IO24VDC	-	power supply for inputs/outputs	I
8	IO24VDC	IO24VDC	-	power supply for inputs/outputs	I
9	Q_0 / Q_0	AUTOM_ACK	high	AUTOM_ACK: Acknowledgement signal at AUTOM signal	O
10	Q_1 / Q_1	AXIS_ADD_IN FO	high	AXIS_ADD_INFO: Supplementary info on current movement job	O
11	Q_2 / Q_2	AXIS_END	high	AXIS_END: End of processing of a movement job, drive at standstill	O
12	Q_3 / Q_3	AXIS_ERR	high	AXIS_ERR: Error detection during a movement job	O
13	Q_4 / Q_4	RDY_TSO	high	RDY_TSO: ready for operation, active in operating status 4 to 7, output max. 400 mA	O
14	TRIGGER	TRIGGER	high	Trigger output, signal value is switched via position/signal list	O
15	ACTIVE_CON	ACTIVE_CON	high	Motor with current, control signal for TLHBC holding brake controller, output max. 400 mA ¹⁾	O
16	ACTIVE_0V	ACTIVE_0V	high	earth to ACTIVE_CON	O
17	ANALOG_IN+	ANALOG_IN+	-	analogue control input $\pm 10V$	I
18	ANALOG_IN-	ANALOG_IN-	-	analogue control input 0 V, reference potential to pin 17 ANALOG_IN+	I
19	BAUD_1 / I_0	MAN_P	high	BAUD_1: Bit 0 for setting the baud rate MAN_P: manual movement clockwise motor rotation	I
20	BAUD_2 / I_1	MAN_N	high	BAUD_2: Bit 1 for setting the baud rate MAN_N: manual movement anticlockwise motor rotation	I
21	BAUD_4 / I_2	MAN_FAST	high	BAUD_4: Bit 2 for setting the baud rate MAN_FAST: Manual selection slow or fast	I
22	CAPTURE1 oder I_5	FAULT_RESET	high	CAPTURE1: input for precise capture of position values (high sampling rate) FAULT_RESET: Reset error message	I
23	CAPTURE2 oder I_6	CAPTURE2 oder I_6	high	CAPTURE2: input for precise capture of position values (high sampling rate)	I

Pin	Signal at IO_mode=0/1	Signal at IO_mode=2	active	Meaning	I/O
24	ADR_64 / I_7	TEACH_IN	high	ADR_64: Bit 6 for the network address TEACH_IN: Trigger signal for saving the current setpoint position in the list data memory	I
25	$\overline{\text{REF}}$	$\overline{\text{REF}}$	low ²⁾	reference switch signal	I
26	$\overline{\text{LIMP}}$	$\overline{\text{LIMP}}$	low ²⁾	limit switch signal clockwise motor rotation	I
27	$\overline{\text{LIMN}}$	$\overline{\text{LIMN}}$	low ²⁾	limit switch signal anticlockwise motor rotation	I
28	$\overline{\text{STOP}}$	$\overline{\text{STOP}}$	low ²⁾	stop motor	I
29	MODE_2 / I_4	AUTOM	high	MODE_2: Bit1 for setting the field bus profile AUTOM: Automatic mode (high) or manual mode (low), acknowledged by AUTOM_ACK	I
30	MODE_1 / I_3	ENABLE	high	MODE_1: Bit0 for setting the field bus profile ENABLE: Enable (high) or lock (low) power amplifier	I

1) IP54 controller: Holding brake connection hard-wired.

2) signal level at default setting of parameter "Settings.SignEnabl" and "Settings.SignLevel"

Minimum interface assignment

The following signal interface connections must be made:

- Pin 26: $\overline{\text{LIMP}}$
- Pin 27: $\overline{\text{LIMN}}$
- Pin 28: $\overline{\text{STOP}}$
- Pin 31 and Pin 33: 24 V power supply
- Pin 7 and pin 8 must be connected to pin 31, even if the signal interface is not used.

Cable specifications

Cables for digital signals:

- minimum cross-section 0.14 mm², max. cross-section 1.5 mm²
- maximum length with minimum cross-section 15 m
- For example: Belden 7400A (2 x 0.5 mm²) to Belden 7408A (25 x 0.5 mm²) cable or similar.

Cables for analogue signals:

- minimum cross-section 0.14 mm², max. cross-section 1.5 mm²
- Shielded twisted-pair cable
- maximum length 18 m

Function

The controller can be controlled manually or automatically, report operating status and control peripherals via the signal interface.

The signal interface is primarily designed for field bus mode. Signal inputs such as MAN_N, MAN_P or AUTOM and outputs such as AXIS_ERR, AXIS_END or AUTOM_ACK are not required here. In field bus mode these signals are changed and evaluated using receive and send data.

The signal interface can operate in three pin assignment modes:

- Address, baud rate and field bus profile setting in field-bus mode
- free assignment of interface
- fixed assignment of interface

Address and baud rate setting in field-bus mode

Condition: parameter `Settings.IO_mode = 0:`

When the 24V power supply is switched on the address and baud rate setting is read from the input signals.

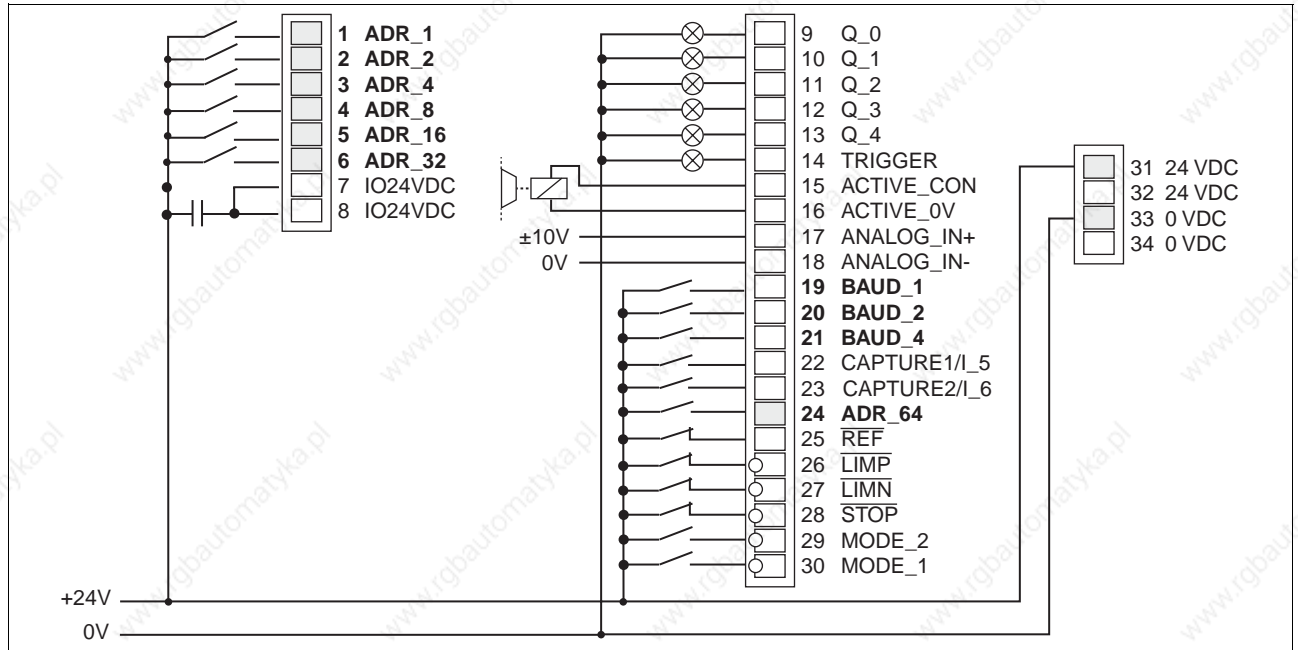

Figure 4.18 Signal interface inputs for field bus addressing

Network address

The network address is bit-coded via inputs ADR_1 to ADR_64. ADR_1 is the lowest value bit.

Network address	ADR_1 ¹⁾	ADR_2 ¹⁾	ADR_4 ¹⁾	ADR_8 ¹⁾	ADR_16 ¹⁾	ADR_32 ¹⁾	ADR_64
0 ²⁾	0	0	0	0	0	0	0
1	1	0	0	0	0	0	0
2	0	1	0	0	0	0	0
3	1	1	0	0	0	0	0
...
126	0	1	1	1	1	1	1
127	1	1	1	1	1	1	1

1) Required for DeviceNet
2) ModBus: address 247

Example: For address 17 the inputs ADR_16 and ADR_1 24 V control (logical 1). The other inputs remain open (logical 0).

Baud rate

For the CAN-C, RS485-C and MODB-C field bus modules the baud rate can be preset bit-coded over the BAUD_1 to BAUD_4 inputs when the controller is started.

baud rate CAN-C	baud rate RS485-C	baud rate MODB-C	BAUD_4	BAUD_2	BAUD_1
20 kbaud	1200 baud	1200 baud	0	0	0
125 kBaud ¹⁾	9600 baud	2400 baud	0	0	1
250 kbaud ¹⁾	19.2 kbaud	4800 baud	0	1	0

baud rate CAN-C	baud rate RS485-C	baud rate MODB-C	BAUD_4	BAUD_2	BAUD_1
500 kbaud ¹⁾	38.4 kbaud	9600 baud	0	1	1
800 kbaud	reserved	19200 baud	1	0	0
1 Mbaud	reserved	reserved	1	0	1
reserved	reserved	reserved	1	1	0
reserved	reserved	reserved	1	1	1

1) Can be set with DeviceNet.

If an illegal baud rate is set, field bus processing cannot be activated. The controller issues an error message on a connected operating unit. A network string can only be operated at one baud rate which must be set on all controllers.

CAN-C profile setting

For the CAN-C field bus module, the field bus profile can be set in bit-coded form via inputs MODE_1 and MODE_2 when the controller is started up.

Profile	MODE_2	MODE_1
CAN bus	0	0
CANOpen profile	0	1
DeviceNet profile	1	0

A network string can only be operated with one network profile which must be set on all controllers.

MODB-C profile setting

For the MODB-C field bus module, the field bus profile can be set in bit-coded form via inputs MODE_1 and MODE_2 when the unit is started up.

Profile	MODE_2	MODE_1
Modbus-ASCII, 7 bit, even, 1 stop	0	0
Modbus-RTU, 8 bit, even, 1 stop	0	1
Modbus-RTU, 8bit, odd, 1stop	1	0
reserved	1	1

A network string can only be operated with one network profile which must be set on all units.

free assignment of interface Parameter Settings.IO_mode = 1:

With free interface assignment, inputs I_0 to I_13 and outputs Q_0 to Q_4 can be assigned additional functions by field bus commands.

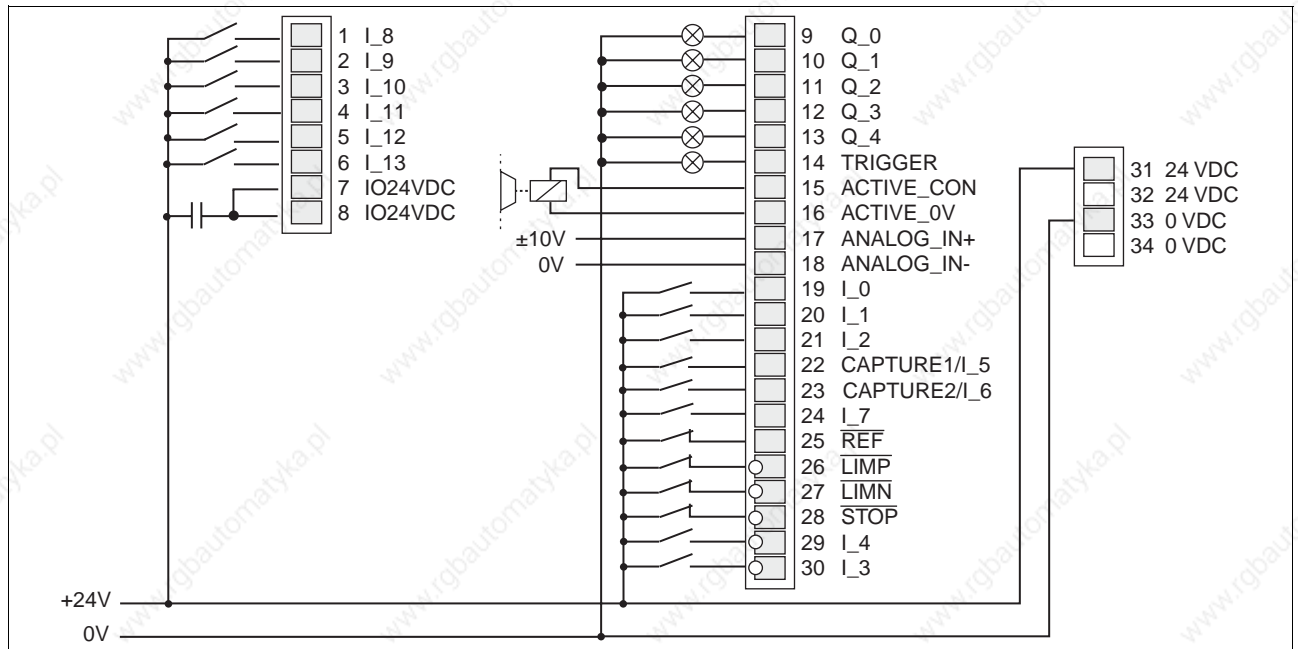

Figure 4.19 Signal interface inputs and outputs for free assignment

Input and output signal states can be read and changed via parameters:

- Read input signals with the parameter I/O.IW1_act
- Write output signals with the parameter I/O.QW0_act

For details see 5.4.6 „Setting and testing signal interface“ on page 5-17.

fixed assignment of interface Parameter Settings.IO_mode = 2:

With fixed assignments control and switching signals for manual mode and teach-in are available on the signal interface. Switching among different access channels is possible over the AUTOM input (local mode, remote mode).

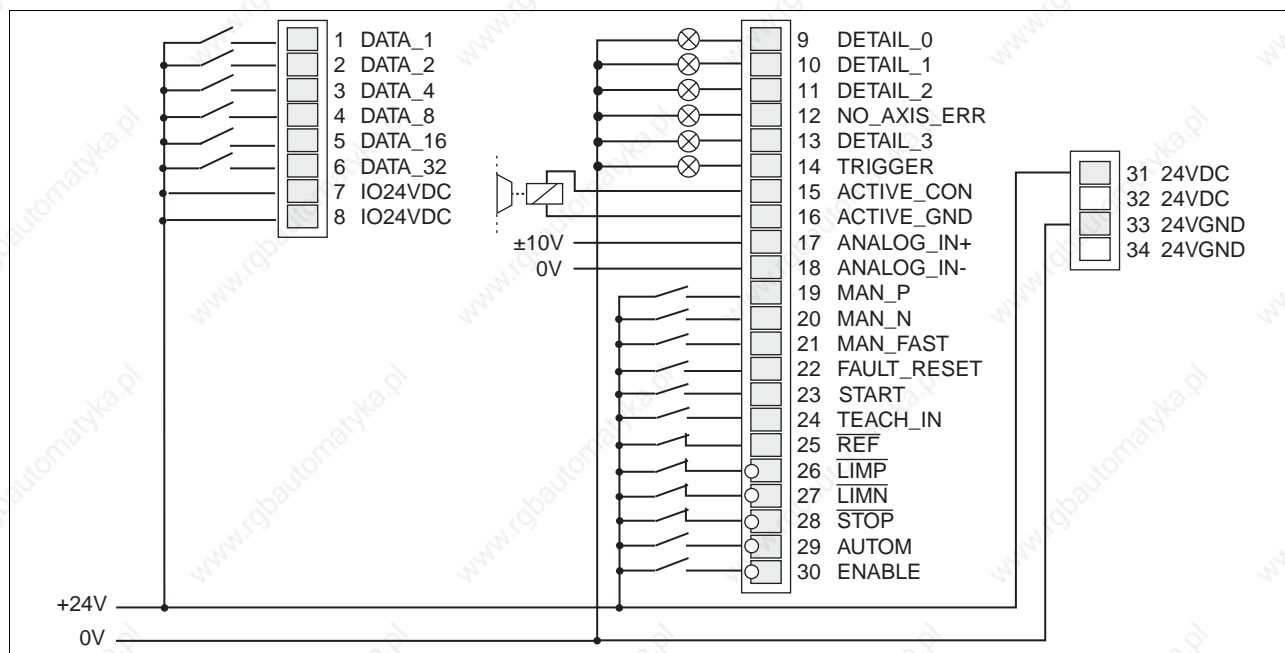

Figure 4.20 Signal interface inputs and outputs with fixed assignment

The manual operation is described on page 6-10 and Teach-In operation on page 7-7.

Signal interface LEDs

Five LEDs at the signal interface show when current is flowing through signal inputs.

The controller interrupt the movement mode as soon as one of the input signals $\overline{\text{LIMP}}$, $\overline{\text{LIMN}}$ or $\overline{\text{STOP}}$ is active.

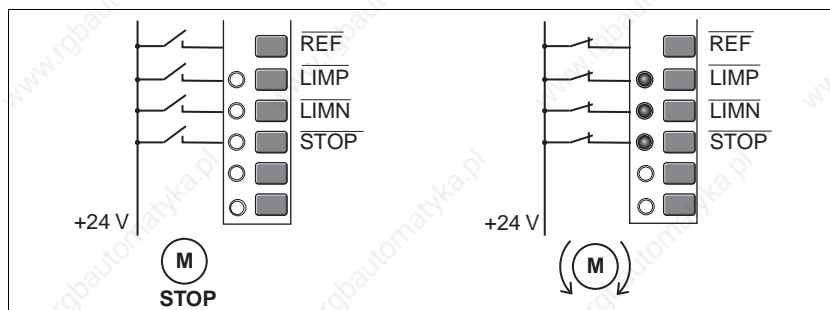

Figure 4.21 LED display of signal interface

The release of the input signals $\overline{\text{LIMP}}$, $\overline{\text{LIMN}}$, $\overline{\text{REF}}$ and $\overline{\text{STOP}}$ and the evaluation to active Low or High can be changed with the parameters Settings.SignEnabl and Settings.SignLevel:

Output signals remain unchanged for at least 0.5 ms.

4.4.9 Connection to the RS232 interface

Terminal The RS232 interface with Sub-D socket, 9-pin with M3 screw connection is wired 1:1 with the PC or the TLHMI. The controller supplies the TLHMI with the operating voltage via PIN 9.

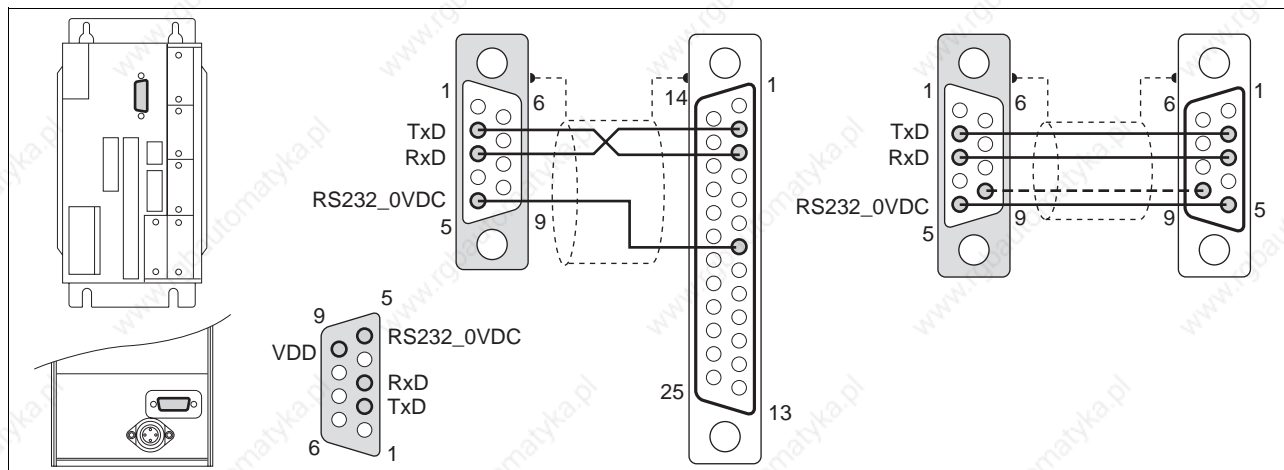

Figure 4.22 Cables for the RS232 interface to the PC or the TLHMI view: Solder side of cable connectors

Pin	Signal	Colour ¹⁾	Pair	Meaning	I/O
1	-	-	-	not assigned	-
2	TxD	brown	-	Transmitted data to input device	O
3	RxD	white	-	Data received from input device	I
4	-	-	-	not assigned	-
5	RS232_0VDC	green	-	Reference potential	-
6	-	-	-	not assigned	-
7	-	-	-	not assigned	-
8	-	-	-	not assigned	-
9	VDD	yellow	-	10 V _{DC} power supply only required for TLHMI	O

1) Information on the colour refers to the cables available as accessories.

Cable specifications

- Shielded cable
- cable length maximum 15 m
- minimum cross-section of the signal conductors 0.25 mm², for supply voltage and earth line 0.5 mm
- shield grounded at both ends
- Use prefabricated cables to minimise the risk of a wiring fault. For matching cables see page 10-1

Equipotential bonding conductors

In digital cables the shields are connected at both ends to protect against interference. Potential differences can result in excessive currents on the shield and must be prevented by equipotential bonding conductor cables. For cables of up to 200m (650 feet) in length a cross section of 16mm² (5 AWG) is sufficient, but for greater lengths a cable cross section of 20mm² (4 AWG) is required.

Function The controller is started and operated over the RS232 interface. Connect the TLHMI hand-held operating unit or a PC with the TLCT commissioning software.

The TLHMI can be connected directly to the unit or connected to the unit with a cable. It is powered by the unit.

Multiple units cannot be networked via the RS232 interface.

4.4.10 Connection to the RS422-C module

Module interface The RS422-C module is fitted with a 15-pin Sub-D socket with M3 screw connection.

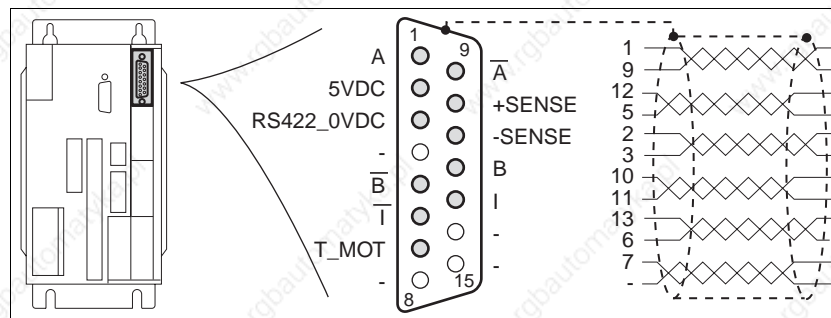

Figure 4.23 Interface of the encoder module

Pin	Signal	Colour ¹⁾	Pair	Meaning	I/O
1	A	white	1	Encoder signal channel A	I
9	\bar{A}	brown	1	Encoder signal channel A, negated	I
12	B	green	2	Encoder signal channel B	I
5	\bar{B}	yellow	2	Encoder signal channel B, negated	I
2 ²⁾	5VDC	red	3	Encoder supply, 5V, max. 300 mA	O
3	RS422_0VDC	blue	3	Reference potential	O
10	+SENSE	purple	4	Sense line positive connect on encoder side to 5VDC ³⁾	I
11	-SENSE	black	4	Sense line negative connect on encoder side to RS422_0VDC ³⁾	I
13	I	grey	5	Channel index pulse	I
6	\bar{I}	pink	5	Channel index pulse, negated	I
7 ²⁾	T_MOT (5VDC)	grey/pink	6	Line monitoring connect signal at encoder to 5VDC	I
4	-	red/blue	6	not assigned	-
8	-	-	-	not assigned	-
14	-	-	-	not assigned	-
15	-	-	-	not assigned	-

1) Information on the colour refers to the cables available as accessories.

2) Connect signals 2 (5VDC) and 7 (T_MOT) for line monitoring in the encoder plug together

3) Sense line must be connected for the 5VDC to be active.

For units with a hood, the cable must be led upwards from the point of connection.

Cable specifications

- Shielded cable
- Minimum cross-section of the signal conductors 0.25 mm², 5VDC and 5VGND 0.5 mm²
- Twisted-pair cables
- Shield grounded at both ends
- Maximum cable length 100m

- Use prefabricated cables to minimise the risk of a wiring fault. For matching cables see page 10-1

Equipotential bonding conductors

In digital cables the shields are connected at both ends to protect against interference. Potential differences can result in excessive currents on the shield and must be prevented by equipotential bonding conductor cables. For cables of up to 200m (650 feet) in length a cross section of 16mm² (5 AWG) is sufficient, but for greater lengths a cable cross section of 20mm² (4 AWG) is required.

Function

Setpoints are specified via externally injected A/B signals and index pulse in electronic gear mode

The RS422-C module receives the A/B encoder signals and index pulses as position setpoint for the controller. The maximum input frequency is 400 kHz.

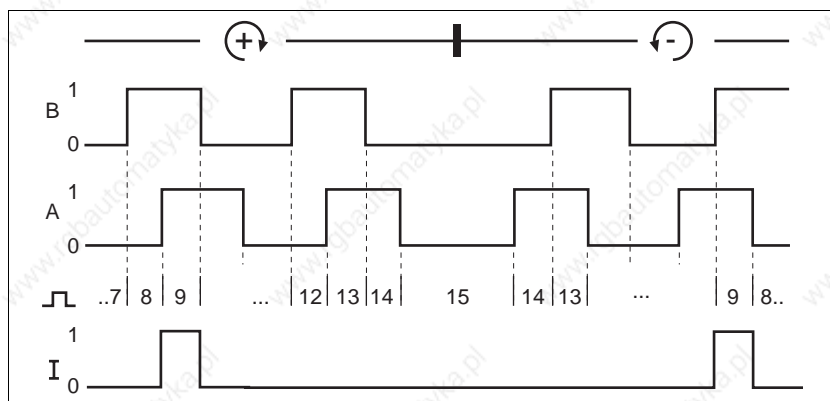

Figure 4.24 Timing diagram with A, B and index pulse signal, counting forwards and backwards

The pin assignments for the relevant signals of the ESIM3-C module are identical. A 1:1 cable can be used for a connection.



Connection of an additional incremental encoder to the M1 interface and activation of the position control at M1 with the aid of a special setting (see 7.13 „Position control with additional incremental encoder“, p. 7-44) the actual position value is shown via M1 - and no longer via M2. The "electronic gear" operating mode can no longer be run in this case.

Monitoring

The T_MOD signal displays wire break at low signal.

4.4.11 Connection to the PULSE-C module

Module interface The PULSE-C module is fitted with a 15-pin Sub-D socket with M3 screw connection.

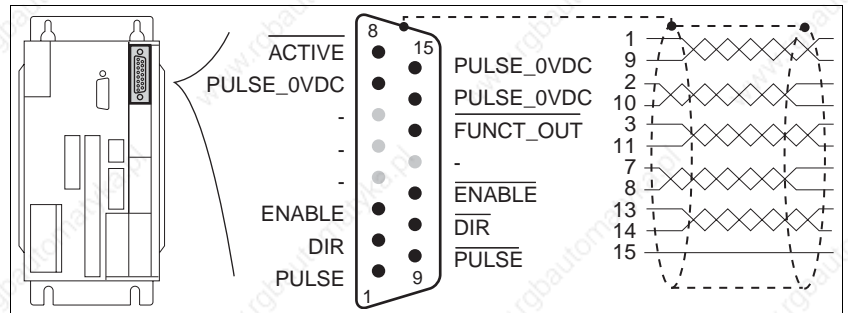

Figure 4.25 Interface of the pulse/direction module

Pin	Signal	Colour ¹⁾	Pair	Meaning	I/O
1	PULSE	white	1	Motor step 'Pulse' or motor step forwards 'PV'	I
9	$\overline{\text{PULSE}}$	brown	1	Motor step 'Pulse' or motor step forwards 'PV', inverted	I
2	DIR	green	2	Direction of rotation 'Dir' or motor step backwards 'PR'	I
10	$\overline{\text{DIR}}$	yellow	2	Direction of rotation 'Dir' or motor step backwards 'PR', inverted	I
3	ENABLE	grey	3	Enable signal	I
11	$\overline{\text{ENABLE}}$	pink	3	Enable signal, inverted	I
7	PULSE_0VDC	grey/pink	4	Reference potential internally via resistor to 0VDC ²⁾	I
8	$\overline{\text{ACTIVE}}$	red/blue	4	Drive ready ³⁾	O
13	$\overline{\text{FUNCT_OUT}}$	white/green	5	reserved, internally to Low level	O
14	PULSE_0VDC	brown/green	5	Reference potential internally via resistor to 0VDC ²⁾	I
15	PULSE_0VDC	white/yellow	6	Reference potential internally via resistor to 0VDC ²⁾	I
4	-	blue	-	not assigned	-
12	-	red	-	not assigned	-
5	-	black	-	not assigned	-
6	-	purple	-	not assigned	-

1) Information on the colour refers to the cables available as accessories.

2) PTC 4 ohm resistance

3) Open collector output, emitter connected with pin 8

For units with a hood, the cable must be led upwards from the point of connection.

Cable specifications

- Shielded cable
- Minimum cross section of the signal wires 0.14 mm²
- Twisted-pair cables
- Shield grounded at both ends



Equipotential bonding conductors

- Maximum length:
100m at RS422 connection
10m at open collector connection
- Use prefabricated cables to minimise the risk of a wiring fault. For matching cables see page 10-1

The PULSE-C module cannot be used for position control with additional incremental encoders at M1.

In digital cables the shields are connected at both ends to protect against interference. Potential differences can result in excessive currents on the shield and must be prevented by equipotential bonding conductor cables. For cables of up to 200m (650 feet) in length a cross section of 16mm² (5 AWG) is sufficient, but for greater lengths a cable cross section of 20mm² (4 AWG) is required.

Function

Setpoints are specified via externally injected pulse direction signals in electronic gear mode

Reference signals for step-by-step positioning of the motor and a control signal for enabling the power amplifier are transmitted via the pulse direction interface. The unit simultaneously signals operational readiness of the drive or a possible malfunction via the interface.

PULSE (PV), DIR (PR)

The square-wave signals PULSE (PV) and DIR (PR) can be combined for two operating modes. The operating mode is set with the parameter M1 . PULSE-C.

- PULSE/DIR: Pulse direction signal
PV/PR: Pulse_{forward} - pulse_{back} signal

Pulse direction mode

The motor executes an angular step with the leading edge of the PULSE signal. The direction of rotation is controlled by the DIR signal.

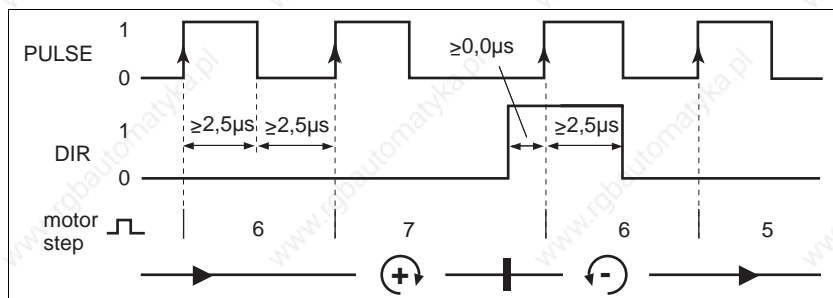

Figure 4.26 Pulse direction signal

Pin	Signal	Function	Value
1, 9	PULSE	Motor step	0 -> 1
2, 10	DIR	positive direction of rotation negative direction of rotation	0 / open 1

Operating mode *pulse_{forward} - pulse_{back}*

The PV (PULSE) signal is used to move the motor in a positive direction, and the PR (DIR) signal moves it in an negative direction.

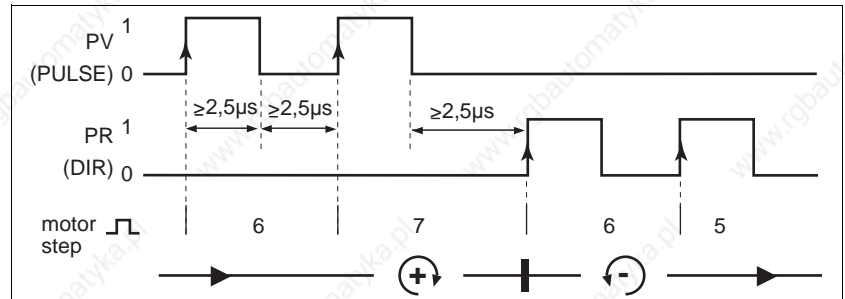

Figure 4.27 Pulse_{forward} - pulse_{back} signal

Pin	Signal	Function	Value
1, 9	PV	Step in positive direction of rotation	0 -> 1
2, 10	PR	Step in negative direction of rotation	0 -> 1

The maximum frequency of PULSE (PV) and DIR (PR) is 200 kHz.

ENABLE

The ENABLE signal enables the power amplifier to enable control of the motor.

Pin	Signal	Function	Value
3, 11	ENABLE	Enable power amplifier	1

If there is no operating fault, the output $\overline{\text{ACTIVE}}$ displays ready for operation for about 100 ms after the power amplifier is enabled.

$\overline{\text{ACTIVE}}$

The output shows that the controller is ready for operation.

Pin	Signal	Function	Value
8	$\overline{\text{ACTIVE}}$	Power amplifier is disabled	1

$\overline{\text{ACTIVE}}$ is an open collector output to GND. The logically negated signal function is available at the ACTIVE_CON output of the signal interface.

Circuit of the signal inputs

**WARNING!**

Unexpected motion may cause injury and damage to the system.

Incorrect or faulty signals as reference position can trigger unexpected movements.

- Use shielded cables with twisted-pair.
- Operate the interface with push-pull signals.
- Do not use signals without push-pull in critical applications or in an environment subject to interference.
- Do not use signals without push-pull with cable lengths over 3 m and limit the frequency to 50 kHz

The diagram shows the circuitry of the signal inputs PULSE (PV), DIR (PR) and ENABLE. Up to 10 inputs of the PULSE-C module can be connected to a RS422 transmitter.

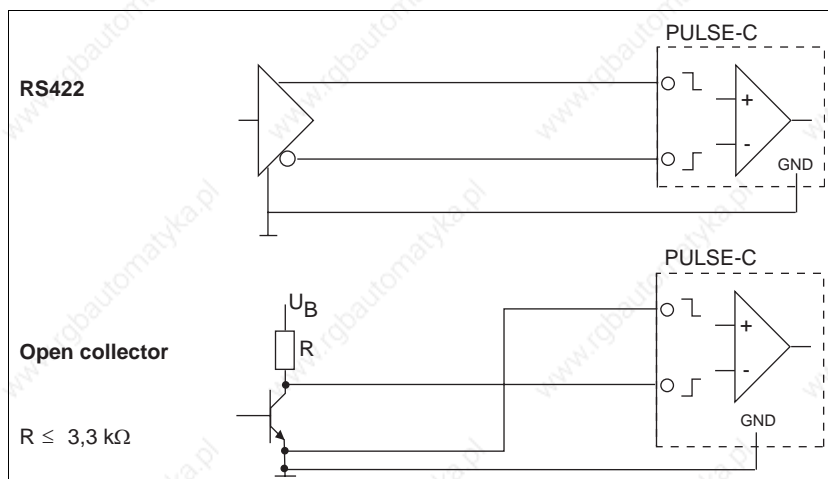

Figure 4.28 Circuit of the signal inputs, L: Cable length

4.4.12 Connection to the IOM-C module

Module interface The IOM-C module is fitted with a 15-pin Sub-D socket with M3 screw connection.

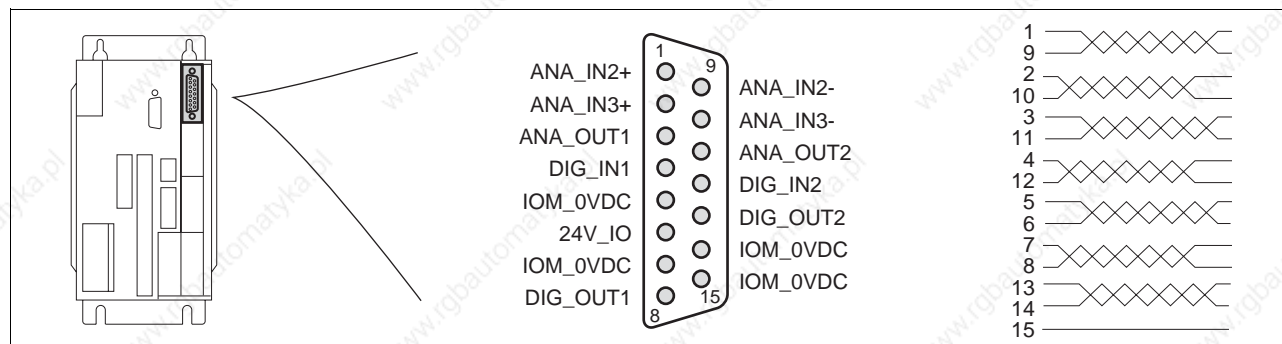

Figure 4.29 Interface of the analogue module

Pin	Signal	Colour ¹⁾	Pair	Meaning	I/O
1	ANA_IN2+	white	1	Analogue control input $\pm 10V$	I
2	ANA_IN3+	green	2	Analogue control input $\pm 10V$	I
3	ANA_OUT1	grey	3	Analogue control output $\pm 10V$	O
4	DIG_IN1	blue	4	Digital control input 1	I
5	IOM_0VDC	black	5	Reference potential	I
6	+24V_IO	purple	5	Power supply, 24 V, for digital control outputs	I
7	IOM_0VDC	grey/pink	6	Reference potential	I
8	DIG_OUT1	red/blue	6	Digital control output 1	O
9	ANA_IN2-	brown	1	Analogue control input 0V, reference potential for pin 1 ANA_IN2+	I
10	ANA_IN3-	yellow	2	Analogue control input 0V, reference potential for pin 2 ANA_IN3+	I
11	ANA_OUT2	pink	3	Analogue control output $\pm 10V$	O
12	DIG_IN2	red	4	Digital control input 2	I
13	DIG_OUT2	white/green	7	Digital control output 2	O
14	IOM_0VDC	brown/ green	7	Reference potential	I
15	IOM_0VDC	white/yel- low	8	Reference potential	I

1) Information on the colour refers to the cables available as accessories.

Cable specifications

For units with a hood, the cable must be led upwards from the point of connection.

- Shield analogue signal lines at one end only at the power controller, shield the other end via capacitor, e.g. 10nF/100V MKT
- Minimum cross section of the signal wires 0.14 mm²
- Twisted-pair cables
- maximum length 5 m

Function The IOM-C analogue module enhances the user interface:

- Two analogue inputs for measuring analogue voltages between +/- 10 V; parameter values of analogue inputs/outputs belong to parameter group M1.
- Two analogue outputs for providing analogue voltages in the +/- 10 V range; parameter values of analogue inputs/outputs belong to parameter group M1.
- Two digital signal inputs for recording 24 V signals; diagram of the digital inputs/outputs in the I/O parameter group.
- Two digital signal outputs for output of 24 V signals; diagram of the digital inputs/outputs in the I/O parameter group.

The connection of pin 6 to 24 V_{DC} is required for the function of the digital signal outputs.



WARNING!

Unexpected motion may cause injury and damage to the system.

When the controller starts (after switching on the +24VDC or power failure), the analogue output of the IOM-C module is at +10V. If the output is connected with a downstream drive, the downstream drive may move unexpectedly.

- Do not enable the downstream drive power amplifier until all units in the system have started.

4.4.13 Connection to the HIFA-C module

Module interface The HIFA-C module is fitted with a 15-pin Sub-D socket with M3 screw connection.

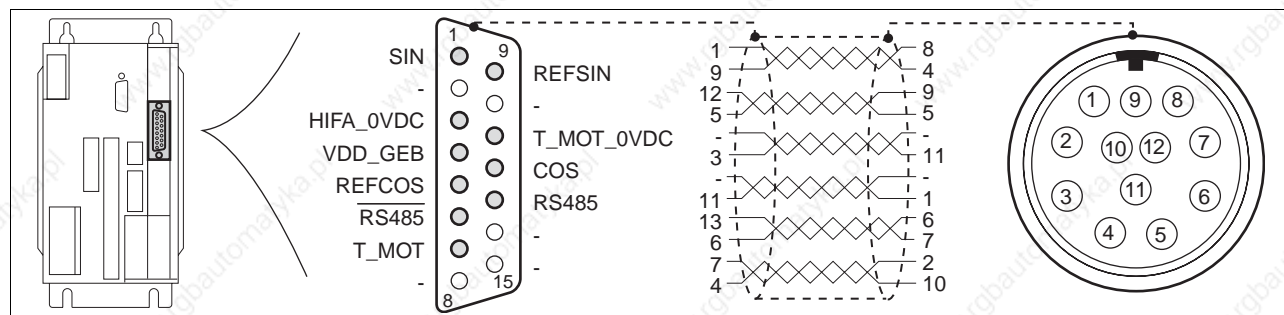

Figure 4.30 Interface of the Hiperface module, plug for AC servomotor, view from solder side

Pin	Signal	Motor, pin	Colour ¹⁾	Pair	Meaning	I/O
1	SIN	8	white	1	Sine signal	I
9	REFSIN	4	brown	1	Reference for sine signal, 2.5 V	O
12	COS	9	green	2	Cosine signal	I
5	REFCOS	5	yellow	2	Reference for cosine signal, 2.5V	O
2	-	-	-	3	not assigned	-
3	HIFA_0VDC	11	blue	3	Reference potential	O
10	-	-	-	4	not assigned	-
11	T_MOT_0VDC	1	black	4	Reference potential to T_MOT	-
13	RS485	6	grey	5	Receive and send data	I/O
6	RS485	7	pink	5	Receive and send data, inverted	I/O
7	T_MOT	2	grey/pink	6	Temperature sensor PTC/NTC	I
4	VDD_GEB	10	red/blue	6	10 V power supply for encoder, max. 150 mA	O
8	-	-	-	-	not assigned	-
14	-	-	-	-	not assigned	-
15	-	-	-	-	not assigned	-

1) Information on the colour refers to the cables available as accessories.

For units with a hood, the cable must be led upwards from the point of connection.

Cable specifications

- Shielded cable
- Minimum cross-section of the signal conductors 0.25 mm², 5V_{GND} 0.5 mm²
- Twisted-pair cables
- Shield grounded at both ends
- Maximum cable length 100 m
- Use prefabricated cables to minimise the risk of a wiring fault. For matching cables see page 10-1

Equipotential bonding conductors

In digital cables the shields are connected at both ends to protect against interference. Potential differences can result in excessive currents on the shield and must be prevented by equipotential bonding conductor cables. For cables of up to 200m (650 feet) in length a cross section of 16mm² (5 AWG) is sufficient, but for greater lengths a cable cross section of 20mm² (4 AWG) is required.

Function

SinCos connection for position response of motor position to the controller.

The SinCoder in the motor captures the rotor position of the motor and sends analogue and digital position data to the HIFA-C Hiperface module. The controller also reads the motor parameter set from the SinCoder memory over the digital interface of the module.

An encoder can be connected to the Hiperface module. Three encoder types manufactured by Stegmann are supported.

Encoder type	Sine/cosine periods per revolution
SinCoder SNS50/60	1 or 1024
SinCos SRS50/60	1024, single-turn encoder
SinCos SRM50/60	1024, multiturn encoder (4096 revolutions)

A fine interpolation is run for these encoder types so the motor can approach 16384 positions per revolution.

Temperature monitoring

The winding temperature of the motor is monitored with a PTC or NTC temperature sensor in the motor and sent to the controller with the T_MOT signal.

The temperature monitoring for the PTC S+M type B59135-M155-A70 or the NTC sensor S+M type B57227 is factory-set.

The controller can operate with a PTC from the following software version

unit	Software version
TLD13x	1.018
TLC43x	1.203
TLC53x	1.004
TLC63x	1.005

When using motors with a PTC temperature sensor the motor temperature `Status.TM_act (31:24)` object does not send valid values. The use of the object is only approved with a motor with an NTC temperature sensor.

Wire break

The T_MOT signal is monitored for wire breakage and short circuit when used with a PTC.

4.4.14 Connection to the RESO-C module

Module interface The RESO-C module is fitted with a 15-pin Sub-D socket with M3 screw connection.

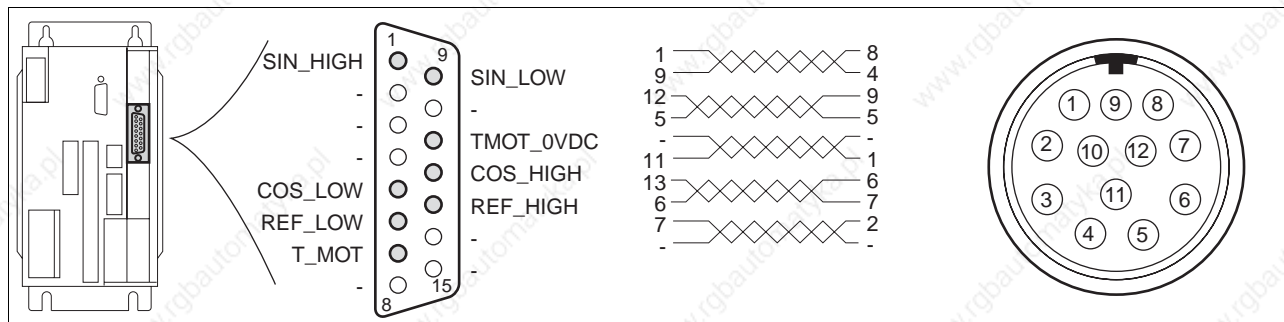

Figure 4.31 Interface of the resolver module, plug for AC servomotor, view from solder side

Pin	Signal	Motor, pin	Colour ¹⁾	Pair	Meaning	I/O
1	SIN_HIGH	8	white	1	Sine input high	I
9	SIN_LOW	4	brown	1	Sine input low	I
12	COS_HIGH	9	green	2	Cosine input high	I
5	COS_LOW	5	yellow	2	Cosine input low	I
10	-	-	purple	3	not assigned	-
11	TMOT_0VDC	1	black	3	Reference potential to T_MOT	I
13	REF_HIGH	6	grey	4	Exciter voltage	O
6	REF_LOW	7	pink	4	Exciter voltage, shifted 180°	O
7	T_MOT	2	grey/pink	5	Temperature sensor PTC/NTC	I
4	-	-	red/blue	5	not assigned	-
2	-	-	-	-	not assigned	-
3	-	-	-	-	not assigned	-
8	-	-	-	-	not assigned	-
14	-	-	-	-	not assigned	-
15	-	-	-	-	not assigned	-

1) Information on the colour refers to the cables available as accessories.

For units with a hood, the cable must be led upwards from the point of connection.

Cable specifications

- Shielded cable
- Minimum cross section of the signal wires 0.25 mm²
- Twisted-pair cables
- Shield grounded at both ends
- Maximum cable length 100 m
- Use prefabricated cables to minimise the risk of a wiring fault. For matching cables see page 10-1

Function Resolver connection for position response of motor position to the controller.

The controller sends an exciter voltage, the frequency of which can be set with the parameter `M2.RESO-C`, to the resolver. Depending on the rotor position the signal is returned to the controller amplitude-modulated and as a sine-cosine signal. The resolver module resolves the signals at 12 bit resolution into a digital A/B signal.

The resolver module can only be used with resolvers that register a revolution absolutely. The transformation ratio of the resolver must be 0.5 ± 0.005 .

Temperature monitoring The winding temperature of the motor is monitored with a PTC or NTC temperature sensor in the motor and sent to the controller with the `T_MOT` signal.

The temperature monitoring for the PTC S+M type B59135-M155-A70 or the NTC sensor S+M type B57227 is factory-set.

The controller can operate with a PTC from the following software version

unit	Software version
TLD13x	1.018
TLC43x	1.203
TLC53x	1.004
TLC63x	1.005

When using motors with a PTC temperature sensor the motor temperature `Status.TM_act` (31:24) object does not send valid values. The use of the object is only approved with a motor with an NTC temperature sensor.

Wire break The `T_MOT` signal is monitored for wire breakage and short circuit when used with a PTC.

4.4.15 Connection to the ESIM3-C module

Module interface The ESIM3-C module is fitted with a 15-pin Sub-D socket with M3 screw connection.

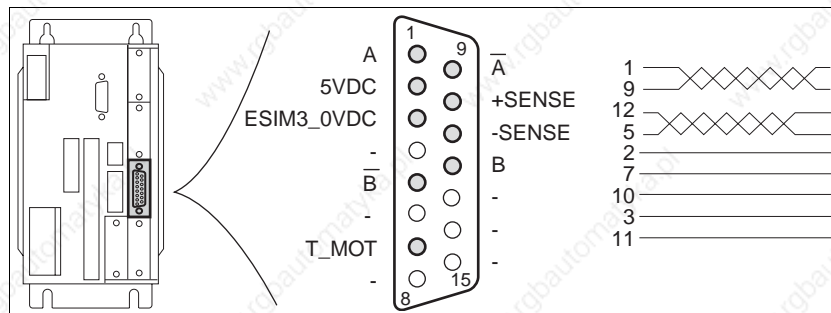

Figure 4.32 Interface connection of the modules for encoder simulation

Pin	Signal	Colour ¹⁾	Pair	Meaning	I/O
1	A	white	1	Channel A	O
9	\bar{A}	brown	1	Channel A, negated	O
12	B	green	2	Channel B	O
5	\bar{B}	yellow	2	Channel B, negated	O
2	5VDC	red	3	Internal bridge to pin 10 for activation of +SENSE Internal bridge to pin 7 for activation of T_MOT ²⁾	I
3	ESIM3_0VDC	blue	3	Internal bridge to Pin 11 to activate -SENSE ²⁾	I
10	+SENSE	purple	4	Internal bridge to Pin 2 to activate +SENSE ²⁾	O
11	-SENSE	black	4	Internal bridge to Pin 3 to activate -SENSE ²⁾	O
13	-	-	-	not assigned	O
6	-	-	-	not assigned	O
7	T_MOT	grey/pink	6	Internal bridge to Pin 2 to activate T_MOT ²⁾	O
4	-	red/blue	6	not assigned	-
8	-	-	-	not assigned	-
14	-	-	-	not assigned	-
15	-	-	-	not assigned	-

1) Information on the colour refers to the cables available as accessories.

2) Only required for connection to RS422-C

For units with a hood, the cable must be led downwards from the point of connection.

Cable specifications

- Shielded cable
- Minimum cross section of the signal wires 0.14 mm²
- Twisted-pair cables
- Shield grounded at both ends
- Maximum length 100 m
- Use prefabricated cables to minimise the risk of a wiring fault. For matching cables see page 10-1

Equipotential bonding conductors

In digital cables the shields are connected at both ends to protect against interference. Potential differences can result in excessive currents on the shield and must be prevented by equipotential bonding conductor cables. For cables of up to 200m (650 feet) in length a cross section of 16mm² (5 AWG) is sufficient, but for greater lengths a cable cross section of 20mm² (4 AWG) is required.

Function

Signals for output of the actual position are sent out at the incremental encoder connection. They are two out-of-phase signals A and B. The A/B signals are generated and sent by the motor-encoder module.

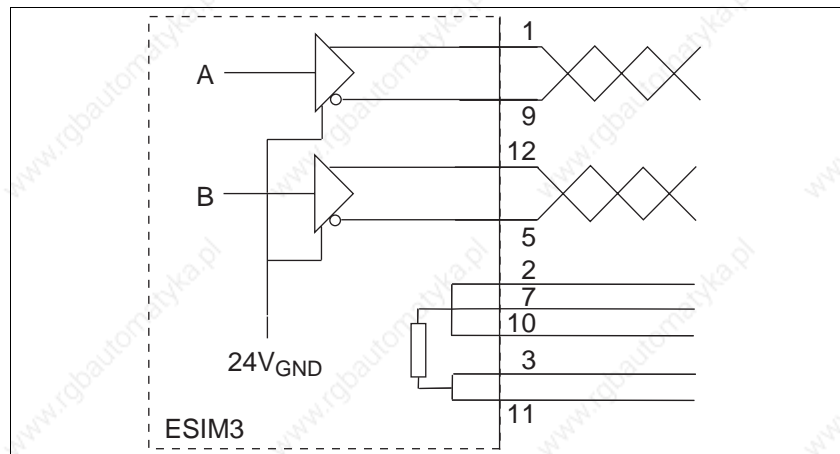

Figure 4.33 Circuit for ESIM3C

Resolution

Basic resolutions of the encoder simulation at quadruple resolution:

SinCos: 4096 increments per revolution

Resolver: 4096 increments per revolution

The resolution can be configured, see page 7-45.

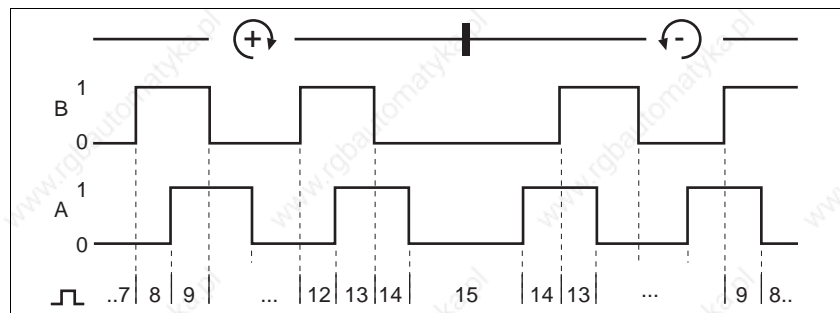

Figure 4.34 Timing diagram with A and B signal, counting forwards and backwards

The pin assignment for the signals of the ESIM3-C and RS422-C modules are identical. A 1:1 cable can be used for a connection.

4.4.16 Connection to the SAM-C module

Module interface The SAM safety module (safety monitor) allows safety functions for personnel protection to be integrated into the Twin Line positioning drives for protection against dangerous movements.

All relevant information can be found in the separate SAM operating manual.

4.4.17 Connection to the PBDP-C module

Module interface The PBDP-C module is fitted with a 9-pin, SUB-D socket, with UNC thread.

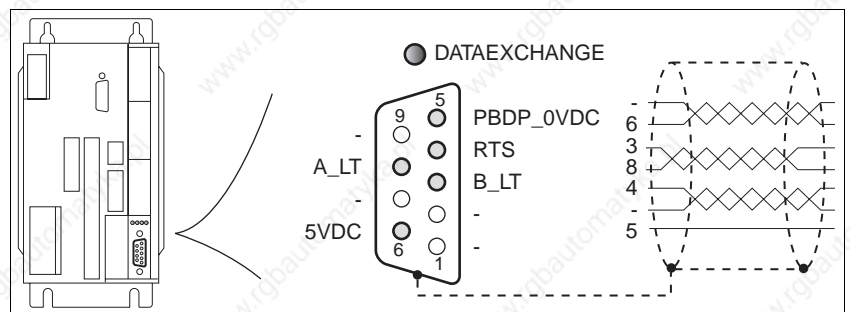

Figure 4.35 Interface connection of the field bus module

Pin	Signal	Colour	Pair	Meaning	I/O
1	-	-	1	not assigned	-
6	5VDC	-	1	Supply voltage, max. 10 mA for terminator	O
2	-	-	-	not assigned	-
7	-	-	-	not assigned	-
3	B_LT	-	2	data wire, inverted	I/O
8	A_LT	-	2	data wire	I/O
4	RTS	-	3	transmission request	O
9	-	-	3	not assigned	-
5	PBDP_0VDC	-	-	Reference potential	-

A bus terminal forms the docking station to the Profibus. Data lines between module and bus terminal are wired up 1:1.

Terminals A_LT and B_LT must be connected to wires A and B in the network in accordance with the minimum wiring requirement.

For units with a hood, the cable must be led downwards from the point of connection.

Cable specifications

- Shielded cable
- Minimum cross section of the signal wires 0.14 mm²
- Twisted-pair cables
- Shield grounded at both ends
- Maximum length 100 m

- Use prefabricated cables to minimise the risk of a wiring fault. For matching cables see page 10-1

Equipotential bonding conductors

In digital cables the shields are connected at both ends to protect against interference. Potential differences can result in excessive currents on the shield and must be prevented by equipotential bonding conductor cables. For cables of up to 200m (650 feet) in length a cross section of 16mm² (5 AWG) is sufficient, but for greater lengths a cable cross section of 20mm² (4 AWG) is required.

Function

The controller can be connected to a Profibus-DP network with the PBDP-C field bus module.

The controller receives data and commands from a higher-level bus device, a master. The controller sends status information such as device status and processing status back to the master device as acknowledgement. Data exchange is with a special communications protocol.

Data are exchanged cyclically between master and slave devices. Every device in the network is identified by a unique address which can be set as desired.

Display

The DATAEXCHANGE LED displays signal connection to the Profibus master device.

Setting the address

The address can be set with the parameter `M4.addrPbd` or the inputs `ADR_1` to `ADR_64` of the signal interface. See page 4-31

Baud rate

The baud rate is determined by the transmission speed of the master device.

Field bus manual

The integration of a Twin Line unit into the field bus is described in the relevant field bus manual in the chapter on set-up.

4.4.18 Connection to the CAN-C module

Module interface The CAN-C module is fitted with a SUB-D plug and a SUB-D socket, both 9-pole with UNC thread. Pin assignment is identical for both interface connections.

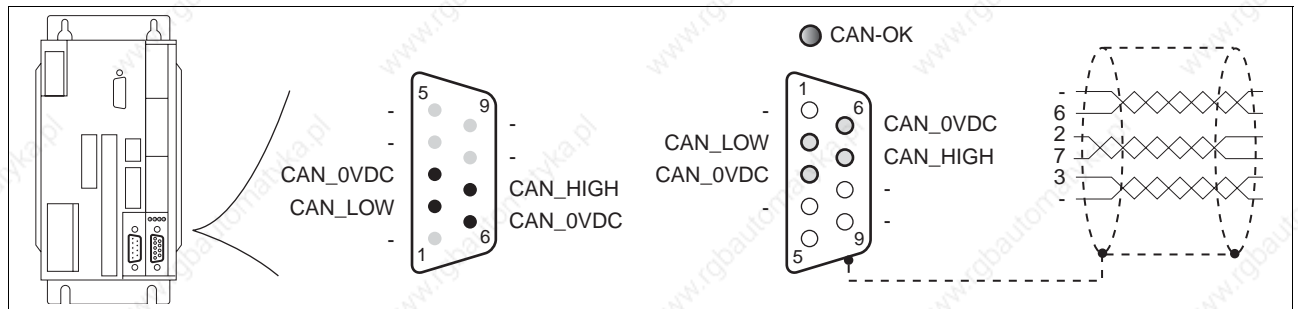

Figure 4.36 Field bus module interface connections with plug and socket

Pin	Signal	Colour ¹⁾	Pair	Meaning	I/O
1	-	-	1	not assigned	-
6	CAN_0VDC	green	1	Reference potential	-
2	CAN_LOW	white	2	data wire, inverted	I/O
7	CAN_HIGH	brown	2	data wire	I/O
3	CAN_0VDC	grey	3	Reference potential	-
8	-	pink	3	not assigned	-
4	-	-	-	not assigned	-
9	-	-	-	not assigned	-
5	-	-	-	not assigned	-

1) Information on the colour is based on the cables available as accessories – the colours are used in accordance with the CAN guidelines. Note that the colours do not conform to the DeviceNet specifications.

For units with a hood, the cable must be led downwards from the point of connection.

Cable specifications

- Shielded cable
- Minimum cross section of the signal wires 0.14 mm²
- Twisted-pair cables
- Shield grounded at both ends
- Maximum length depends on the number of devices, the baud rate and signal run times. The higher the baud rates the shorter the bus cable must be.
- Use prefabricated cables to minimise the risk of a wiring fault. For matching cables see page 10-1

Maximum bus length The maximum bus length depends on the selected baud rate. The following table shows the maximum recommended bus lengths for the overall length.

baud rate [kbit/s]	maximum bus length with CANopen and DeviceNet [m]
20	2500
125	500
250	250
500	100
800	25
1000	4

Because of the electrical isolation of the controller shorter cable lengths than specified in other documentation are permitted.

At a baud rate of 1 Mbit the spur lines are limited to 0.3m.

Equipotential bonding conductors In digital cables the shields are connected at both ends to protect against interference. Potential differences can result in excessive currents on the shield and must be prevented by equipotential bonding conductor cables. For cables of up to 200m (650 feet) in length a cross section of 16mm² (5 AWG) is sufficient, but for greater lengths a cable cross section of 20mm² (4 AWG) is required.

Function When using the CAN-C field bus module the controller can be connected to the following networks:

- CAN bus
- CANOpen
- DeviceNet

As a slave the controller receives data and commands from a higher-level bus device, a master. The controller sends status information such as device status and processing status back to the master device as acknowledgement. Data exchange is with a special communications protocol.

As a CANOpen master the controller sends data and commands to lower-level bus devices, the slaves. Data exchange is with a special communications protocol.

When operated as a CANOpen master the setting of the field bus profile must be CAN bus.

Every unit in the network is identified by a unique node address which can be set as desired.

CAN-Bus display The LED "CAN-OK" on the CAN-C module lights for about 2 seconds when field bus data have been correctly received.

CANOpen display The LED "CAN-OK" on the CAN-C module lights when there is a connection to the unit. If the connection is broken, the LED flashes: 0.5 sec on/0.5 sec off.

DeviceNet display The LED "CAN-OK" on the CAN-C module displays the status of the DeviceNet node:

DeviceNet status	Display
OFFLINE	flashes (0.2 sec on / 0.8 sec off)
ONLINE	flashes (0.8 sec on / 0.2 sec off)
LINK_OK	on
TIMEOUT/FAILURE	flashes (0.2 sec on / 0.2 sec off)

Setting the address The address can be set with the parameter `M4.addrPbd` or the inputs `ADR_1` to `ADR_64` of the signal interface. See page 4-31

Baud rate The baud rate can be set with the parameter `M4.baudCan` or the inputs `BAUD_1` to `BAUD_4` of the signal interface. See page 4-31

Field bus profile The field bus profile can be set with the parameter `M4.profilCan` or over the inputs `MODE_1` and `MODE_2`. See page 4-32

Terminating resistors A terminating resistor of $120\ \Omega$ must be connected between `CAN_LOW` and `CAN_HIGH`. For an appropriate terminal plug see page 10-1

Field bus manual The integration of a Twin Line unit into the field bus is described in the relevant field bus manual in the chapter on set-up.

4.4.19 Connection to the RS485-C module

Module interface The RS485-C module is fitted with a Sub-D socket and a Sub-D plug, both 9-pin with M3 thread. Pin assignment is identical for both interface connections.

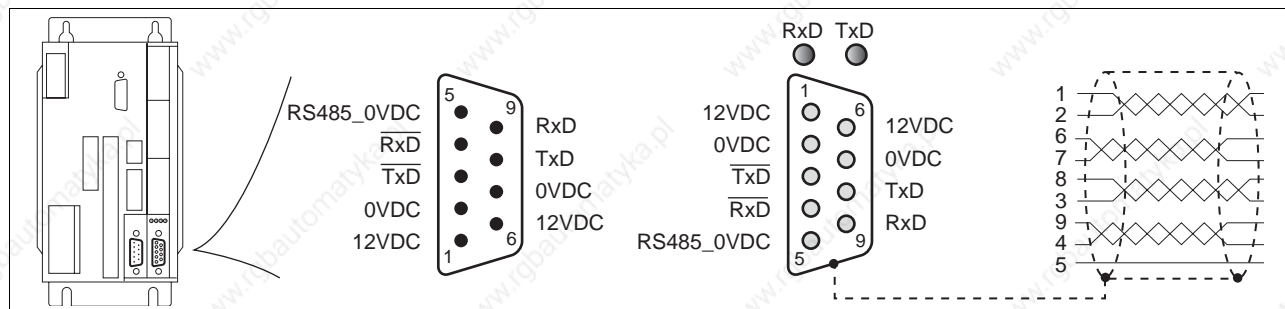

Figure 4.37 Interface connection of the field bus module

Pin	Signal	Colour	Pair	Meaning	I/O
1	12VDC	white	1	Supply voltage	O
2	0VDC	brown	1	Reference potential to 12VDC	O
6	12VDC	green	2	Supply voltage	O
7	0VDC	yellow	2	Reference potential to 12VDC	O
8	TxD	pink	3	Transmitted data	O
3	TxD̄	grey	3	transmission data, inverted	O
9	RxD	red	4	Received data	I
4	RxD̄	blue	4	received data, inverted	I
5	RS485_0VDC	black	-	Reference potential	-

Only one 12VDC output of the two Sub-D connections may be loaded with a current of max. 150 mA.

Cable specifications

- Shielded cable
- Minimum cross section of the signal wires 0.14 mm²
- Twisted-pair cables
- Shield grounded at both ends
- maximum length 400 m
- Use prefabricated cables to minimise the risk of a wiring fault. For matching cables see page 10-1

For units with a hood, the cable must be led downwards from the point of connection.

Equipotential bonding conductors

In digital cables the shields are connected at both ends to protect against interference. Potential differences can result in excessive currents on the shield and must be prevented by equipotential bonding conductor cables. For cables of up to 200m (650 feet) in length a cross section of 16mm² (5 AWG) is sufficient, but for greater lengths a cable cross section of 20mm² (4 AWG) is required.

- Function** The controller can be connected to a serial bus as a slave with the RS485-C field bus module.
- The controller receives data and commands from a higher-level bus device, a master. The controller sends status information such as device status and processing status back to the master device as acknowledgement. Data exchange is with a special communications protocol.
- Every device in the network is identified by a unique address which can be set as desired.
- Display** Two LEDs on the RS485-C module show the transfer of transmitted and received data.
- Setting the address** The address can be set with the parameter `M4.addrSer` or the inputs ADR_1 to ADR_16 of the signal interface. See page 4-31
- Baud rate** The baud rate can be set with the parameter `M4.baudSer` or the inputs BAUD_1 to BAUD_4 of the signal interface. See page 4-31
- Field bus manual** The integration of a Twin Line unit into the field bus is described in the relevant field bus manual in the chapter on set-up.

4.4.20 Connection to the MODB-C module

The module is fitted with a Sub-D socket and a Sub-D plug, both 9-pin with UNC threads. Pin assignment is identical for both interface connections.

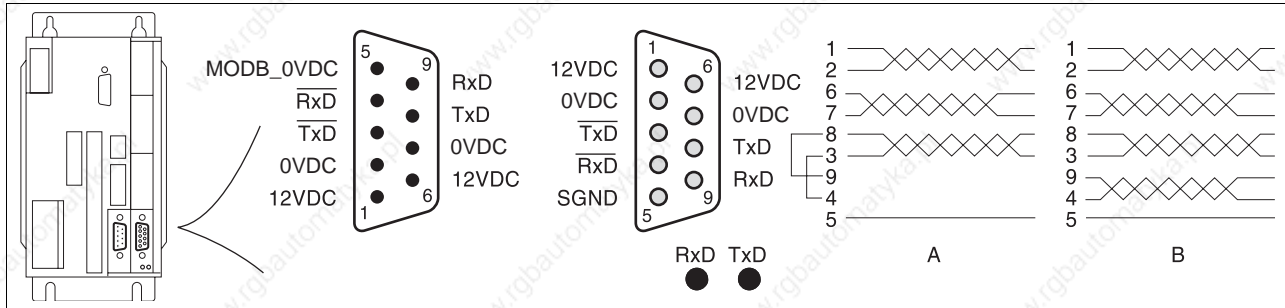

Figure 4.38 A: 2-wire, B: 4-wire

Pin	Signal	Colour	Pair	Meaning	I/O
1	12VDC	–	1	Power supply voltage	O
2	0VDC	–	1	Reference potential to 12VDC	O
6	12VDC	–	2	Power supply voltage	O
7	0VDC	–	2	Reference potential to 12VDC	O
3	TxD	–	3	Transmitted data	O
8	TxD	–	3	Transmitted data, inverted	O
4	RxD	–	4	Received data	I
9	RxD	–	4	Received data, inverted	I
5	MODB_0VDC	–	–	Reference potential	–

Table 4.39 Pin assignment



Cable specifications

Only one 12VDC output of the two Sub-D connections may be loaded with a current of max. 150 mA.

The cables used must conform to the following properties:

- screened cable,
- minimum cross section of signal wires 0.14mm² (25 AWG),
- twisted pair wires,
- screen earthed at both ends,
- maximum length 400m (1312 feet).

For units with a hood, the cable must be led downwards from the connection.

Equipotential bonding conductors

In digital cables the shields are connected at both ends to protect against interference. Potential differences can result in excessive currents on the shield and must be prevented by equipotential bonding conductor cables. For cables of up to 200m (650 feet) in length a cross section of 16mm² (5 AWG) is sufficient, but for greater lengths a cable cross section of 20mm² (4 AWG) is required.

Display Two LEDs on the module show the transmitted and received data traffic.

Field bus manual The integration of a Twin Line unit into the field bus is described in the relevant field bus manual in the chapter on set-up.

4.4.21 Connection to the IBS-C module

Module interface The IBS-C module is fitted with a Sub-D plug for remote-in and a Sub-D socket for remote-out, both 9-pin with UNC thread.

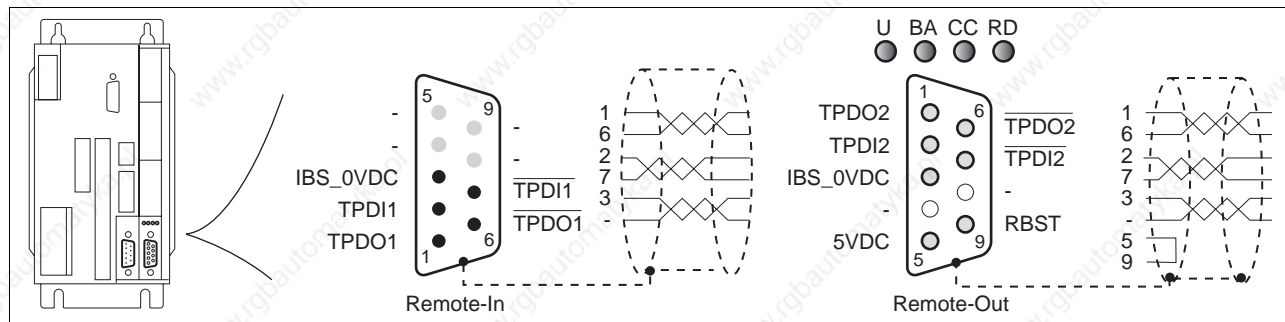

Figure 4.40 Interface connection of the field bus module

Pin	Signal	Signal	Colour ¹⁾	Pair	Meaning	I/O
1	TPDO1	TPDO2	white	1	Received data	I
6	TPDO1	TPDO2	brown	1	received data, inverted	I
2	TPDI1	TPDI2	green	2	Transmitted data	O
7	TPDI1	TPDI2	yellow	2	transmission data, inverted	O
3	IBS_0VDC	IBS_0VDC	blue	3	Reference potential	-
8	-	-	red	3	not assigned	-
4	-	-	grey	-	not assigned	-
9	-	RBST	pink	-	only for Remote-Out: Signal inputs for additional board	I
5	-	5VDC	black	-	only for Remote-Out: 5 V power	O

1) Information on the colour refers to the cables available as accessories.

Cable specifications

For units with a hood, the cable must be led downwards from the point of connection.

- Shielded cable
- Minimum cross section of the signal wires 0.14 mm²
- Twisted-pair cables
- shield grounded at both ends Connect the shield to the Sub-D housing. Do not connect the shield directly to earth, because the housing is internally earthed via a capacitor.
- maximum length 400 m
- Use prefabricated cables to minimise the risk of a wiring fault. For matching cables see page 10-1

Equipotential bonding conductors

In digital cables the shields are connected at both ends to protect against interference. Potential differences can result in excessive currents on the shield and must be prevented by equipotential bonding conductor cables. For cables of up to 200m (650 feet) in length a cross section of 16mm² (5 AWG) is sufficient, but for greater lengths a cable cross section of 20mm² (4 AWG) is required.

Function The controller can be connected as a slave to an Interbus network with the IBS-C field bus module. The Interbus is a standardised field bus for data exchange for sensors and actuators.

During processing the controller exchanges process data with a master device such as a PLC or a PC with an Interbus master interface. The master device controls and monitors all connected slave devices.

Devices on the Interbus are networked in a ring topology. Connection to the neighbouring device is made in each case via Remote-In and Remote-Out.

Display The field bus module signals status and diagnostic information through four LEDs:

LED	Colour	Explanation, if active
U	green	power supply OK
BA	green	remote bus connection OK
CC	green	remote bus OK
RD	red	remote bus to the next slave device switched off

Setting the address The address is derived from the position of the Twin Line unit in the network ring.

Baud rate The baud rate is permanently set to 500 kbit/s.

Field bus manual The integration of a Twin Line unit into the field bus is described in the relevant field bus manual in the chapter on set-up.

4.5 Connecting accessories to the IP20 controller

4.5.1 TLHBC holding brake controller

The brake in motors with a holding brake is controlled by the TLHBC holding brake controller TLHBC. The function is described on page 7-38.

Motor connection

Terminal	Terminal	Colour ¹⁾
U	Motor cable	black L1 (BK)
V	Motor cable	black L1 (BK)
W	Motor cable	black L1 (BK)
PE	Protective conductor	green/yellow (GN/YE)
B+	Brake wire	white (WH)
B-	Brake wire	grey (GR)

1) Colours of older wiring: U = brown (BN), V = blue (BL), W = black (BK), PE = shield filler wire

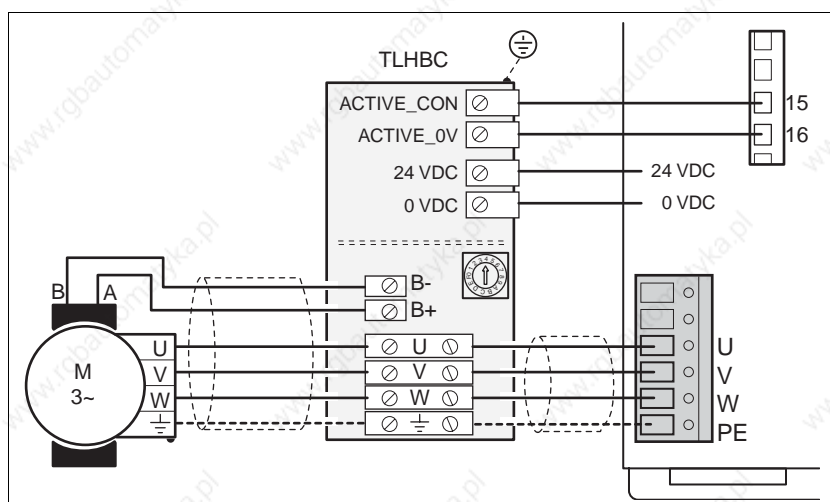

Figure 4.41 Connection of the TLHBC holding brake controller

Note the dimensions shown when sizing the motor cable for connection to the holding brake controller.

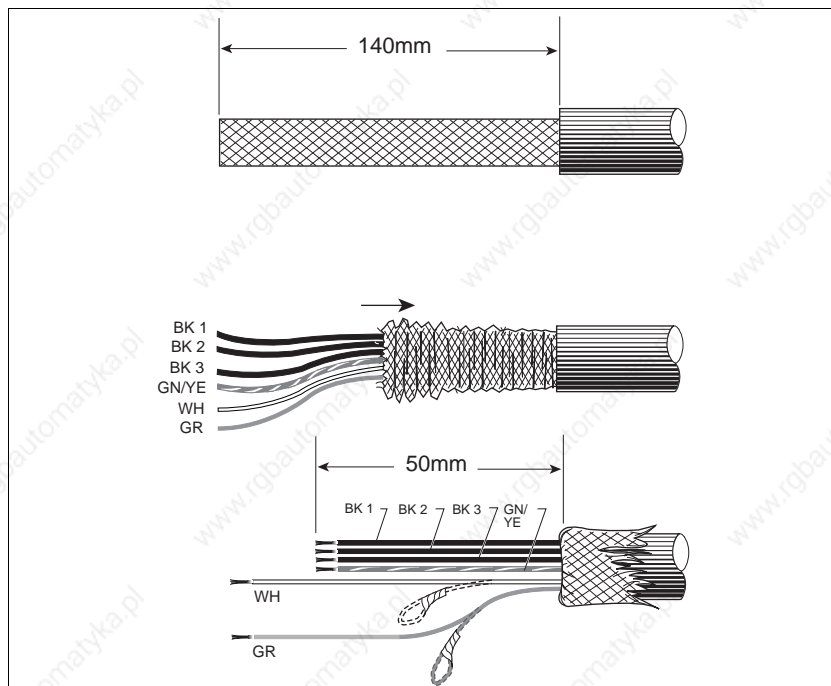

Figure 4.42 Sizing the motor cable for connection to the holding brake controller, dimensions in mm.

*Power connection
Motor and unit side*

- ▶ Only use square end ferrules to ensure that they do not work loose.
- ▶ Connect the black L1 wire to U, black L2 to V, black L3 to W and green/yellow to PE.
- ▶ Slide the shielding terminal over the shield of the motor cable. Use the shield terminal to fix the cable. Use the shielding terminal to fasten the cable to the TLHBC case.

Brake terminal

- ▶ Only use square end ferrules to ensure that they do not work loose.
- ▶ Connect terminal B+ to White and B- to Grey on the motor side
- ▶ Isolate the unused wires at the unit side

Signal connections

- ▶ Only use square end ferrules to ensure that they do not work loose.
- ▶ Connect the control connections ACTIVE_CON and ACTIVE_0V of the holding brake controller and the signal interface together.
- ▶ Connect the 24 VDC terminal of the TLHBC to the 24 VDC terminal on the controller.

Only use cables with the following specifications:

	TLxx32	TLxx34	TLxx36	TLxx38
Cable cross-section [mm ²]	1.5	1.5 to 2.5	1.5 to 2.5	2.5 to 4
Max. cable length ¹⁾ [m]	20	20	20	20

1) Longer cables can be ordered

The holding brake controller's power requirement depends on the switching current for the holding brake:

Brake controller input current [A] = 0.5 A + switching current [A]

► Set the switch for voltage reduction:

The function of the voltage reduction is described in chapter 7.11 „Braking function with TLHBC“ on page 7-38.

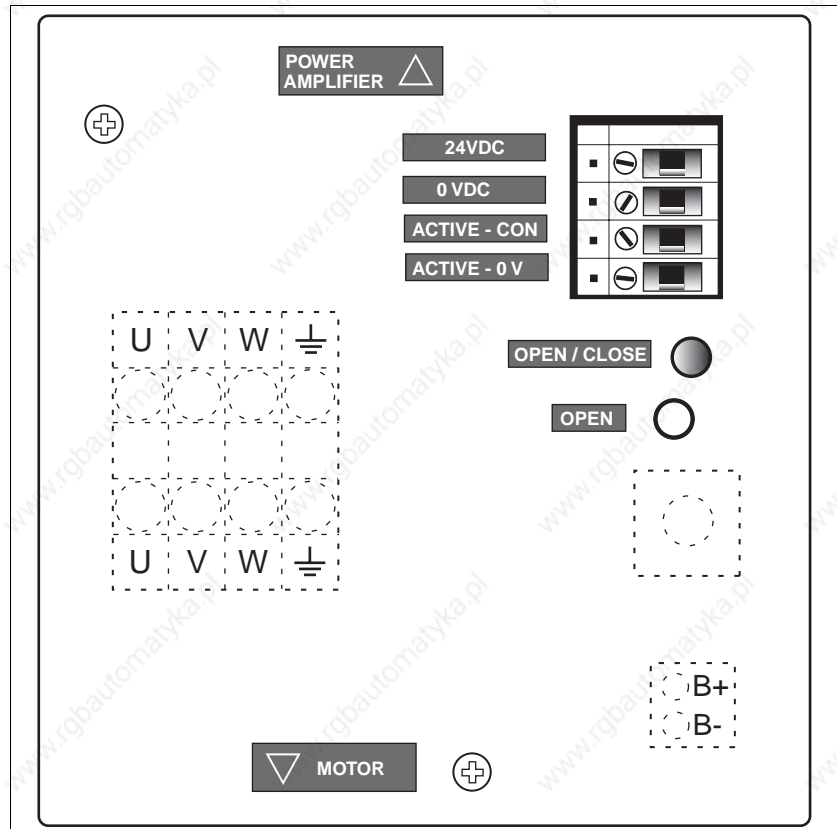

Figure 4.43 TLHBC overview

4.5.2 Ballast resistor and control



WARNING!

Danger of injury and damage to system components by unbraked motor.

An insufficient ballast resistance causes overvoltage at the DC bus and switches off the power amplifier. The motor is no longer actively braked.

- Make sure that the ballast resistor is sufficiently dimensioned.
- Check the setting of the parameter for the ballast.
- Check the temperature of the ballast resistor by conducting a test run under the most critical conditions.
- During the test make sure that at higher line voltage there is less reserve in the capacitors on the DC bus.

External ballast resistor An external ballast resistor can be connected to the DC bus connection of the controller via the TLBRC ballast resistor controller.

An additional external ballast resistor is required when the motor is heavily braked and the internal ballast resistor can no longer dissipate the excess braking energy.

Dimensioning aid The elements contributing towards the absorption of braking energy are calculated to assist in specification. This is used to calculate the size of the ballast resistor.

An additional external ballast resistor is required when the kinetic energy W_{kin} to be absorbed exceeds the sum of the internal shares, including the internal ballast resistor.

Kinetic energy W_{kin} The kinetic energy is calculated from the kinetic or rotational energy of the drive.

Internal energy absorption Braking energy is absorbed internally by the following mechanisms:

- DC bus capacitor W_{ZW}
- Internal ballast resistor W_{IN}
- Electrical losses in the drive W_E
- Mechanical losses in the drive W_M

DC bus capacitors The energy W_{ZW} depends in a square-law function on the difference between the voltage before the braking operation and the response threshold.

The voltage before the braking operation depends on the mains voltage. The energy absorption by the DC bus capacitors is lowest when the mains voltage is highest. Use the values for the highest mains voltage.

unit	mains voltage [V]	TLxx32	TLxx34	TLxx36	TLxx38
Internal capacitance [μ F]		340	235	470	1175
Energy absorption ¹⁾ [Ws]	230	10	53	106	265
Energy absorption ¹⁾ [Ws]	400	-	23	47	116
Energy absorption ¹⁾ [Ws]	480	-	3	7	16

1) The results are based on 10% overvoltage

Energy absorption of the internal ballast resistor Two key values relating to the internal ballast resistor determine its energy absorption.

- The continuous output P_{AV} shows how much energy can be continuously dissipated without overloading the ballast resistor.
- The maximum energy W_{peak} limits the higher heat loss which can be dissipated in the short term.

If the continuous output is exceeded for a specified time, the ballast resistors remain unloaded for a correspondingly period. This ensures that the ballast resistor is not destroyed.

The key values P_{AV} and W_{peak} of the internal ballast resistor can be found from page 3-2.

Electrical losses W_E The electrical losses W_E in the drive can be estimated from the peak power of the drive. The maximum power loss is around 10% of peak power for a typical efficiency factor of 90%. If the current on braking is lower, the power loss will be reduced accordingly.

Mechanical losses W_M The mechanical losses result from absorption by friction, which occurs when the system is running. Mechanical losses can be ignored if the system requires a much longer time to coast to a stop than the time required to stop the system under braking. The mechanical losses can be calculated from the load torque and the speed from which the motor is to stop.

Example TLxx34 Braking of a motor with the following data (AC IN equal to 400VAC):

- Starting speed: $n = 4000 \text{ min}^{-1}$
- Moment of inertia of rotor: $J_R = 4 \text{ kgcm}^2$
- moment of inertia of load: $J_L = 6 \text{ kgcm}^2$

The energy to be absorbed is given by:

$$W_B = 1/2 * J * (2 * \pi * n)^2$$

to 88 Ws

Electrical and mechanical losses are ignored.

23 Ws are absorbed in the DC bus capacitors at a power supply of 400 V.

The internal ballast resistor must absorb the residual 65 Ws. It can absorb a pulse of 80 Ws. The internal ballast resistor is sufficient if the load is stopped once under braking.

If the braking process is repeated cyclically, the continuous output must be considered. If the cycle time is longer than the ratio of the energy to be absorbed W_B and the continuous power P_{AV} , the internal ballast resistor is sufficient. If braking takes place more frequently, the internal ballast resistor will not be sufficient.

The example uses the ratio W_B/P_{AV} at 1.3 s. With a shorter cycle time an external ballast resistor is required with TLBRC.

Dimensioning of the external ballast resistor

The selection of an external ballast resistor is determined by the required peak power and continuous power with which the ballast resistor can be operated.

The resistance value R is given by the peak power required.

$R = U^2 / P_{max}$	U : switching threshold [V] P _{max} : required peak power [W] R : resistance [Ohm] > 28 Ohm
---------------------	---

Figure 4.44 Calculating the resistance R of an external ballast resistor

Select resistors by the following criteria:

- The resistors must be wired in parallel so the required resistance is not exceeded. Note the lower limit of 28 ohms.
- The total continuous output of the individual resistors must yield the required continuous output.

The ballast resistors approved by the manufacturer have the following properties.

	Resistor [W]	Continuous power [W]
BWG 250072	72	100
BWG 250150	150	100
BWG 500072	72	200
BWG 500150	150	200



WARNING!

Hot surfaces can cause burns, fire and damage to system components.

The ballast resistor temperature can exceed 250°C in some conditions.

- Prevent contact with the hot ballast resistor.
- Do not place flammable or heat-sensitive components in the immediate vicinity of the ballast resistor.
- Ensure good heat dissipation.
- Check the temperature of the ballast resistor by conducting a test run under the most critical conditions.

Ballast resistor controller TLBRC

When a high DC bus voltage is reached, the ballast resistor controller switches an external ballast resistor to the DC bus connection of the controller.



CAUTION!

Destruction of the drive system by incorrect parallel operation.

Operation with a non-approved parallel circuit on the DC bus may destroy the drive systems immediately or after a delay.

- Never connect the DC bus of more than two drive systems.
- Never connect the DC bus of drive systems of different power classes.
- Never connect the DC bus of drive systems with 115 V rated voltage.
- Never reverse DC+ and DC-.
- If one drive system on the DC bus requires a line reactor, both drive systems must be fitted with a line reactor.
- Use separate fuses for each drive system.
- Operate both drive systems on the same power system (on the same line fuse), and on the same phase on single-phase systems.

Two units can be connected to the controller when these conditions are considered. The DC bus connections of both units are connected in parallel if they are connected to the same ballast resistor controller.

**DANGER!****Electric shock, fire or explosion**

- Only qualified personnel who are familiar with and understand the contents of this manual and the other relevant manuals are authorised to work on and with this drive system.
- Before working on the drive system:
 - Switch off power to all terminals.
 - Place a sign "DO NOT SWITCH ON" on the switch and lock to prevent switching on.
 - **Wait 6 minutes** (for discharge of DC bus capacitors).
 - Measure voltage between DC+ and DC- and check for <48V. (The DC bus LED is not a safe indication for absence of the DC bus voltage).
- Do not short-circuit DC bus or touch unshielded components or screws of the terminals with voltage present.
- Install all covers and close the housing doors before applying power.
- The motor generates voltage when the shaft is rotated. Lock the shaft of the motor to prevent rotation before starting work on the drive system.
- The system manufacturer is responsible for compliance with all applicable regulations relevant to earthing the drive system.
- Do not reach into the drive system (e.g. no pointed objects).

Two or more ballast resistors can be connected to the ballast resistor controller. If you use two resistors, connect them to the two terminals provided, R+, R- and PE. If you are using more than two resistors in parallel, use wire end ferrules of the right size to connect the resistors.

Setting voltage limit

The ballast resistor controller must be set to the unit connection voltage with a switch in the unit.

**CAUTION!****Destruction of the drive system by incorrect setting.**

The voltage limit for the DC bus must be set at the TLBRC. An incorrect setting acts like a short circuit and can destroy the drive system.

- Set the switch to the 420 V position for drive systems on single-phase power.
- Set the switch to the 760 V position for drive systems on three-phase power.

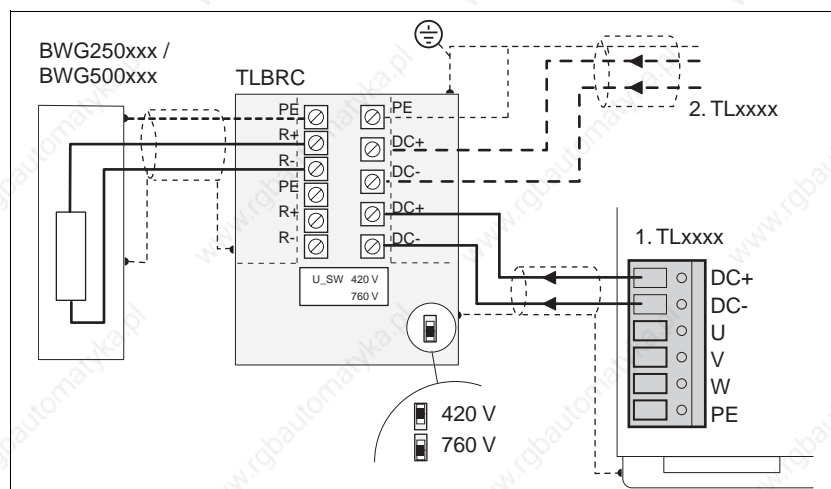

Figure 4.45 Connection of the ballast resistor controller

- ▶ Disconnect the unit from the supply voltage. Open the TLBRC.
- ▶ Set the switch in accordance with the unit connection voltage.
- ▶ Connect the TLBRC to the controller with a 2-strand cable. Connect the DC+ and DC- terminals to the ballast resistor controller with the DC bus terminals DC+ and DC- on the controller.
- ▶ Clamp the cable shield flat to the earth bar of the unit with the accessory SK14 shielding terminal.
- ▶ Connect the PE terminal beside DC+ to the earth bar via a protective conductor.
- ▶ Connect the ballast resistor to the R terminals of the ballast resistor controller with a 3-strand cable. Connect the protective conductor to PE.

- Additional shield terminals are required for a second unit and a second ballast resistor.

Cable specifications

- Shielded wires
- Ground the cable shield at each end
- Maximum cable length: 3m
- minimum cross-section: like mains connection

The ballast resistor controller receives its operating voltage over the DC bus connection.

EMC measures

The DC bus cable is a source of interference and must be laid out carefully:

- The shield braiding of the cable must be laid out over a wide area on the unit housing. Use the earth terminals available as accessories for the housing terminal.
- Exposed cable ends may be unshielded for a distance of less than 20 mm only.

	Switch position 1 ¹⁾	Switch position 2
unit	TL..xx4/xx6/xx8	TL..xx2
Switching threshold [V]	760	420
Maximum switched continuous power [W]	1000	500
Smallest resistance [ohm]	30	30

1) Factory setting

The cable length between TLBRC and the controller may be a maximum of 2 metres.

Unit setting

When using the TLBRC the internal ballast resistor must be switched off. The parameter `Settings.TLBRC` is used to inform the unit whether a ballast resistor controller is connected. Details can be found on page 5-13

IP54 controller

The dissipatable ballast power depends on the ambient temperature and whether or not a fan is being used. The information on power can be found on page 3-6

If the actual ballast output exceeds the maximum possible ballast output, the controller disconnected the connection to the motor.

The maximum permissible ballast output is set with the parameter `PA.P_maxBusr`.

Group.Name	Idx:Six dec (hex)	TLHMI	Explanation and unit []	Value range	Default value	R/W per.
PA.P_maxBusr	16:57 (10:39 _n)	4.1.40	Maximum permissible ballast power [W] Note: This parameter is only visible with the IP54 controller.	UINT16 TLCx32: 25 - 170 W TLCx34: 37 - 255 W	25 37	R/W per.



CAUTION!

Burns and destruction of the controller by overheating.

With IP54 controllers the permissible ballast output is calculated from a parameter. Incorrect input can overheat the unit.

- Set the parameter `P_maxBusr` correctly corresponding to the environmental conditions (temperature with/without fan).
- Check the temperature of the ballast resistor by conducting a test run under the most critical conditions.

Note for commissioning

- The controller does not monitor the external ballast resistor for overheating. The ballast resistor controller will switch off if overheating occurs.
- Test the ballast resistor controller during set-up under realistic conditions.

4.6 Wiring examples

4.6.1 Field-bus mode, Field bus configuration via inputs

Functions Operation only by field bus master device, field bus settings via signal interface inputs. Field bus address 7 is set on switching on the Twin Line unit. Baud rate and processing profile are not set here and are 0 VDC.

Inputs I_5 and I_6 are available as freely assignable inputs, outputs Q_0 to Q_4 as freely assignable outputs.

Presets Parameter setting: Settings.IO_mode = 0

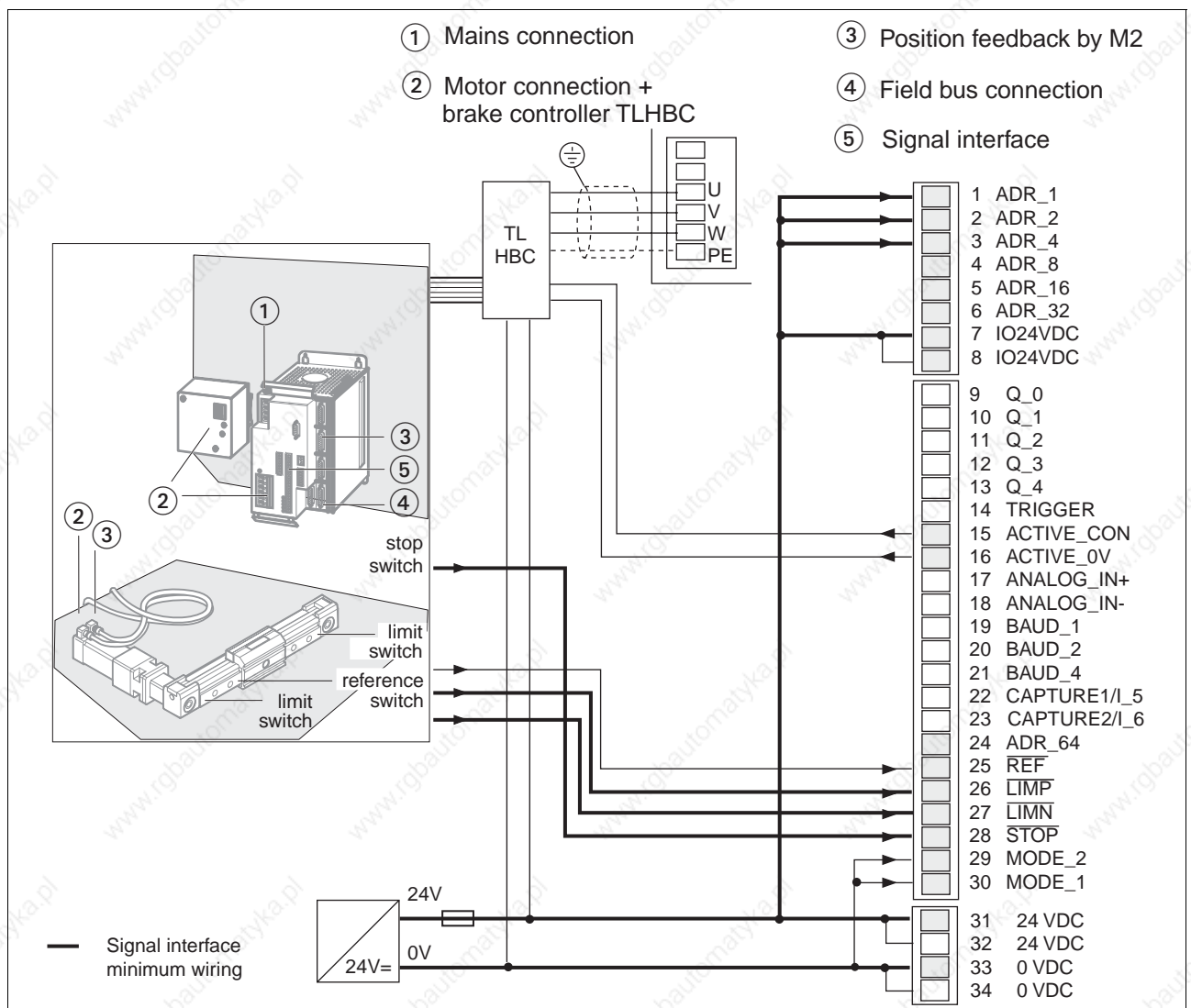

Figure 4.46 Wiring for automatic operation only on field bus

Pin	Signal	active	Meaning	I/O
1	ADR_1	high	Bit 0 for network address	I
2	ADR_2	high	Bit 1 for network address	I
3	ADR_4	high	Bit 2 for network address	I
4	ADR_8	high	Bit 3 for network address	I

Pin	Signal	active	Meaning	I/O
5	ADR_16	high	Bit 4 for network address	I
6	ADR_32	high	Bit 5 for network address	I
7	IO24VDC ¹⁾	–	power supply for inputs/outputs	I
8	IO24VDC	–	power supply for inputs/outputs	I
15	ACTIVE_CON	high	Motor with current, control signal for TL HBC holding brake controller, max. 400 mA ²⁾	O
16	ACTIVE_0V	high	Reference potential to ACTIVE_CON	O
19	BAUD_1	high	Bit 0 for setting the baud rate	I
20	BAUD_2	high	Bit 1 for setting the baud rate	I
21	BAUD_4	high	Bit 2 for setting the baud rate	I
24	ADR_64 ¹⁾	high	Bit 6 for network address	I
25	$\overline{\text{REF}}$	low	reference switch signal	I
26	$\overline{\text{LIMP}}$ ¹⁾	low	limit switch signal clockwise motor rotation	I
27	$\overline{\text{LIMN}}$ ¹⁾	low	limit switch signal anticlockwise motor rotation	I
28	$\overline{\text{STOP}}$ ¹⁾	low	stop motor	I
29	MODE_2	high	Bit1 for setting field bus profile	I
30	MODE_1	high	Bit0 for setting field bus profile	I

1) Minimum assignment of the signal interface for commissioning

2) IP54 controller: Holding brake connection hard-wired.

4.6.2 Field-bus mode, configuration with TLHMI or TLCT

Functions Operation by field bus or local operating units TLHMI or TLCT with signal interface with free pin assignment, field bus settings by local operating units.

Presets Parameter setting: `Settings.IO_mode = 1`

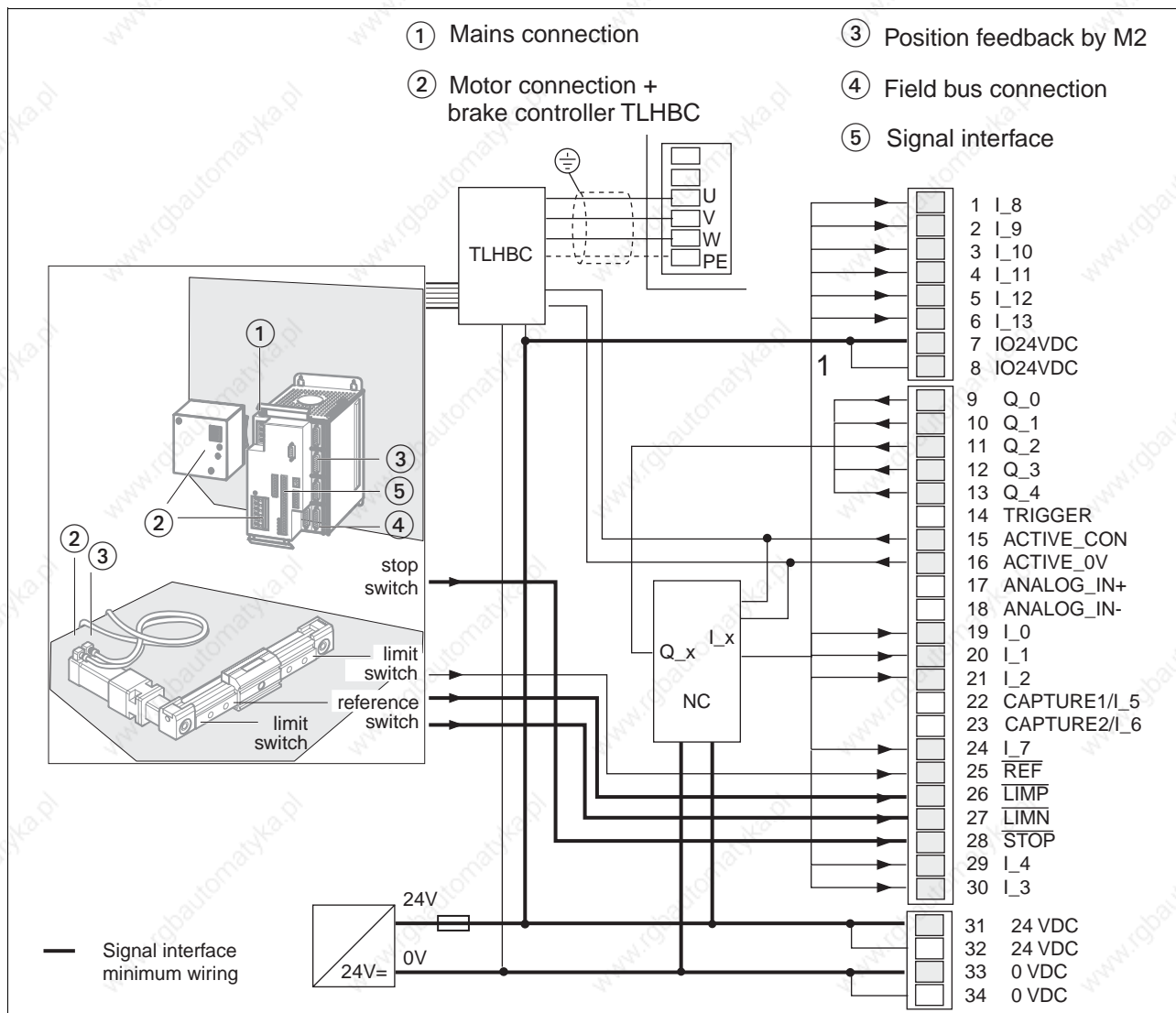

Figure 4.47 Wiring for automated operation on field bus

Pin	Signal	active	Meaning	I/O
1	I_8	high	Freely assignable input	I
2	I_9	high	Freely assignable input	I
3	I_10	high	Freely assignable input	I
4	I_11	high	Freely assignable input	I
5	I_12	high	Freely assignable input	I
6	I_13	high	Freely assignable input	I
7	IO24VDC ¹⁾	-	power supply for inputs/outputs	I

0098 441 113 110, V1.00, 07.2004

Pin	Signal	active	Meaning	I/O
8	IO24VDC	–	power supply for inputs/outputs	I
9	Q_0	high	freely assignable output	O
10	Q_1	high	freely assignable output	O
11	Q_2	high	freely assignable output	O
12	Q_3	high	freely assignable output	O
13	Q_4	high	freely assignable output	O
15	ACTIVE_CON	high	Motor with current, control signal for TL HBC holding brake controller, max. 400 mA ²⁾	O
16	ACTIVE_0V	high	Reference potential to ACTIVE_CON	I
19	I_0	high	Freely assignable input	I
20	I_1	high	Freely assignable input	I
21	I_2	high	Freely assignable input	I
24	I_7	high	Freely assignable input	I
25	REF	low	reference switch signal	I
26	LIMP ¹⁾	low	limit switch signal clockwise motor rotation	i
27	LIMN ¹⁾	low	limit switch signal anticlockwise motor rotation	I
28	STOP ¹⁾	low	stop motor	I
29	I_4	high	Freely assignable input	I
30	I_3	high	Freely assignable input	I

1) Minimum assignment of the signal interface for commissioning

2) IP54 controller: Holding brake connection hard-wired.

4.6.3 Field-bus mode, manual setup

Functions Manual setup with Teach-In function, manual movement via I/O, operation over field bus with fixed I/O pin assignments

Presets Parameter setting: `Settings.IO_mode = 2`

Manual movement via I/O and teach-in: `AUTOM = 0`

Field-bus mode: `AUTOM=1.`

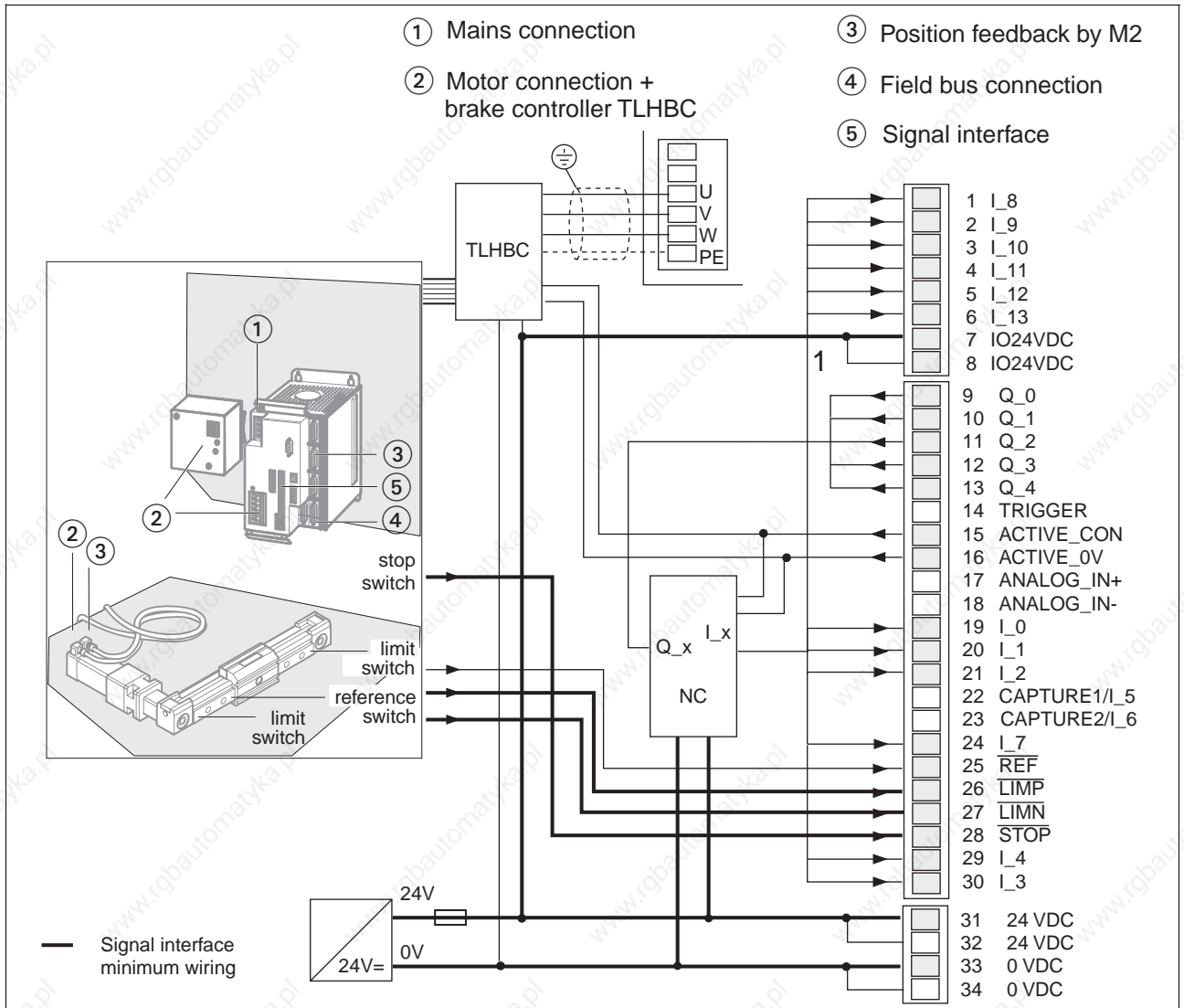

Figure 4.48 Wiring for automated operation on field bus

Pin	Signal	active	Meaning	I/O
1	DATA_1	high	Bit 0 for selecting a list number	I
2	DATA_2	high	Bit 1 for selecting a list number	I
3	DATA_4	high	Bit 2 for selecting a list number	I
4	DATA_8	high	Bit 3 for selecting a list number	I
5	DATA_16	high	Bit 4 for selecting a list number	I
6	DATA_32	high	Bit 5 for selecting a list number	I

0098 441 113 110, V1.00, 07.2004

Pin	Signal	active	Meaning	I/O
7	IO24VDC ¹⁾	–	power supply for inputs/outputs	I
8	IO24VDC	–	power supply for inputs/outputs	I
9	AUTOM_ACK	high	Acknowledgement signal at AUTOM signal	O
10	AXIS_ADD_INFO	high	Supplementary information on current movement job	O
11	AXIS_END	high	End of processing of a movement job, drive at standstill	O
12	AXIS_ERR	high	Error detection during processing of a movement job	O
13	RDY_TSO	high	Ready for operation, output max. 400 mA	O
15	ACTIVE_CON	high	Motor with current, control signal for TLHBC holding brake controller, max. 400 mA ²⁾	O
16	ACTIVE_0V	high	Reference potential to ACTIVE_CON	I
19	MAN_P	high	manual movement clockwise motor rotation	I
20	MAN_N	high	manual movement anticlockwise motor rotation	I
21	MAN_FAST	high	Manual selection slow (low) or fast (high)	I
22	FAULT_RESET	high	Reset error message	I
24	TEACH_IN	high	Trigger signal for saving the current setpoint position in the list data memory	I
25	REF	low	reference switch signal	I
26	LIMP ¹⁾	low	limit switch signal clockwise motor rotation	I
27	LIMN ¹⁾	low	limit switch signal anticlockwise motor rotation	I
28	STOP ¹⁾	low	stop motor	I
29	AUTOM ¹⁾	high	Automatic mode via field bus (high), manual mode (low)	I
30	ENABLE ¹⁾	high	Enable (high) or lock (low) power amplifier	I

1) Minimum assignment of the signal interface for commissioning

2) IP54 controller: Holding brake connection hard-wired.

4.7 Checks

► Carry out these checks:

- Are all protective conductors connected?
- Are all fuses correct?
- Are any live cable ends exposed?
- Are all cables and connectors safely installed and connected?
- Are the control lines connected correctly?
- Have all EMC measures been taken?

For tests and commissioning steps see page 5-7

5 Commissioning

5.1 General safety instructions



WARNING!

Unexpected responses may cause injury and damage to the system.

The behaviour of the drive system is governed by numerous saved data. Unsuitable data may cause unexpected motions or responses to signals.

- Do not operate a unit with unknown data.
- Check the saved data.
- When commissioning carefully run tests for all operating states and fault cases.
- Check the functions after replacing a unit and also after changes to the saved data.
- Start the system only if there are no persons or materials in the danger zone and the system can be operated safely.



WARNING!

Danger of injury and damage to system components by loss of control!

- The system manufacturer must consider the possible errors that could occur with the signals and in particular the critical functions to ensure a safe status during and after errors. Critical functions include emergency stop and limiting end positions. Observe the accident prevention regulations.
- Consideration of possible errors must include unexpected delay and failure of signals or functions.
- Separate redundant controller paths must be provided for critical functions.



WARNING!

Danger of injury and damage to system components by unbraked motor!

Loss of power or faults that result in switching off the power amplifier mean that the motor is no longer actively braked and may run against a mechanical stop at high speed.

- Check the mechanical conditions.
- If necessary, use an absorbent mechanical stop or a suitable brake.

5.2 Overview

Where can I find information on...	device manual	TLHMI manual	TLCT manual	TLCT help
Commissioning step by step	x	–	–	x
Settings and parameter list	x	–	–	–
Commissioning procedure	x	–	–	x
Detailed information on operation using...	–	TLHMI	TLCT	TLCT



Commissioning

The following commissioning steps are also required if you are using a configured unit under changed operating conditions. Incorrectly set values may destroy controller, motor and system components.

What you need to do...	Info
Make sure the Twin Line unit is correctly installed and wired up. When carrying out this check, use the wiring diagrams of the system configuration or the wiring examples in on page 4-71.	Page4-1
Make sure the limit switches work if these are installed.	Page5-11
Check the functioning of the holding brake controller if you are using motors with holding brake.	Page5-12
Set the motor data (applies to resolver motors) When using motors with Hiperface interface and Sincoder or SinCos sensors, this step is not required.	Page5-9
Check and set critical device parameters	Page5-13
Optimise controller settings by installing the motor and... - set reference values and recording data - optimise speed controller - optimise position controller.	Page 5-28 Page 5-31 Page 5-41

Next steps...

After commissioning is completed the unit can be tested in its various operating modes.

- For information on these operating modes see page.6-1
- The signals, parameters and conditions for changing operating modes are described on page .6-1

5.3 Tools for commissioning

Two input routes are at your disposal for commissioning, setting parameters and for diagnostics:

- Twin Line hand-held operating unit "Human Machine Interface", or abbreviated as TLHMI
- TLCT commissioning software used in conjunction with a PC equipped with Windows 98 or newer

The TLCT is required for complete commissioning.

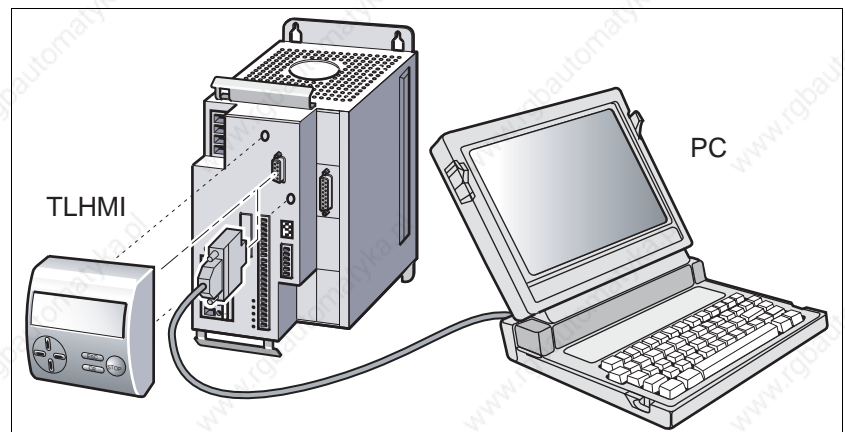

Figure 5.1 Commissioning with the TLHMI hand-held operating unit or PC

Baud rate

Baud rate	TLD13x	TLCxxx
9600	x	x
19200	-	x
38400	-	x

The TLD13x controller must be restarted if it is addressed with an excessively high baud rate.

5.3.1 TLHMI hand-held operating unit

TLHMI hand-held operating unit

The TLHMI is a plug-in hand-held operating unit with an LCD display 3 x 16 characters in size. It is plugged directly into the RS232 interface but can also be connected to the RS232 interface via a serial cable.

TLHMI manual

The operation of a Twin Line unit with the TLHMI hand-held operating unit is described in the TLHMI manual.

Menu structure

The TLHMI is run using a menu. The displayed menu structures and parameter values automatically adapt themselves to the connected device type after the controller is switched on. The following menu items of the first and second level can be selected for this controller:

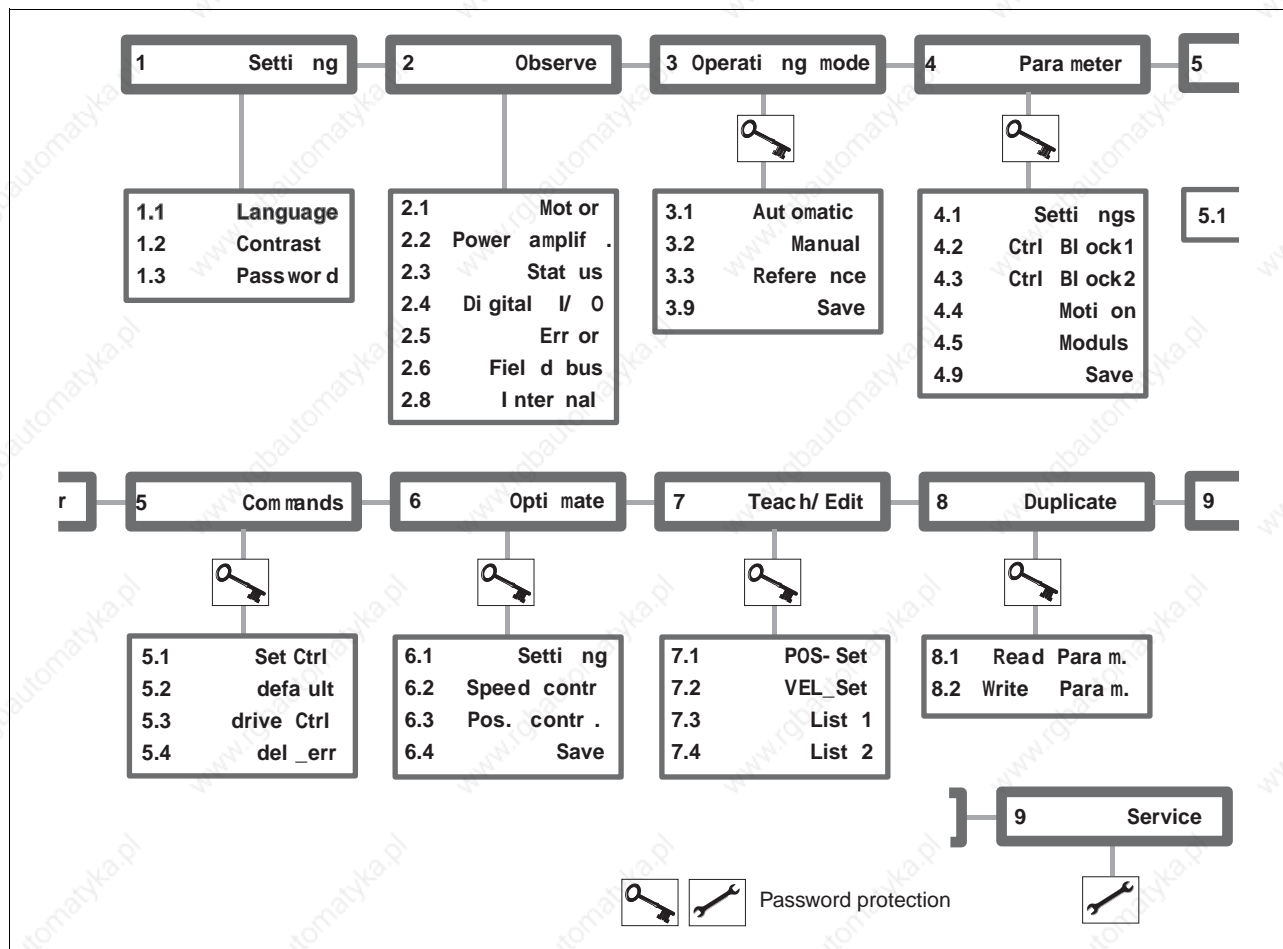

Figure 5.2 First and second menu level of the TLHMI

First menu level	Meaning
1 Settings	TLHMI-specific settings
2 Observe	Device, motor and movement data as well as error displays
3 Operating mode	Selection and launch of the operating mode and settings for the operating mode
4 Parameters	Controller and movement parameters with settings for the controller and the modules
5 Commands	Selection of the control parameters set
6 Optimise	Optimisation of the control loops
7 Teach/edit	Process data for list control with the controller
8 Duplicate	Copy parameter sets to other Twin Line units
9 Service	Password-protected, for servicing purposes only

Menu paths are given in the manual for every parameter to make it easy for you to find all parameters with the TLHMI. TLHMI menu "8.2" operates as follows: On the first menu level select item '8 Duplicate'; next, on the second level, select the menu item '8.2 Write Param.'

Information on the operation of the TLHMI can be found in the "TLHMI" manual.

5.3.2 TLCT commissioning software

TLCT The TLCT commissioning software includes a graphic user interface and the option of loading and saving controller parameters and motor data. You can use the software to test the input and output signals of the controller, follow signal sequences on the screen and optimise the controller behaviour interactively.

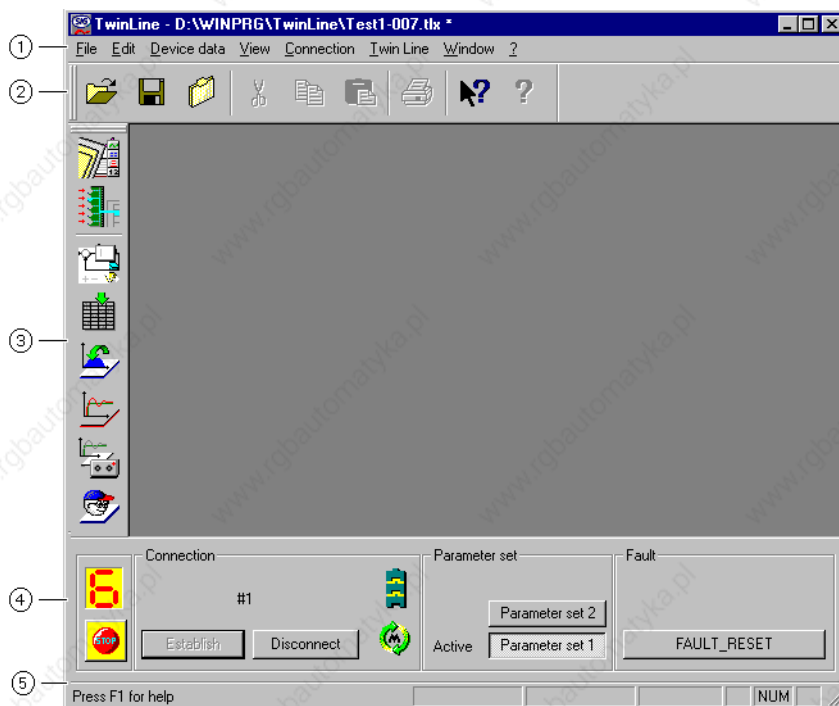

Figure 5.3 TLCT commissioning software

Compared to the TLHMI hand-held operating unit, the software offers extensive options such as:

- Status display of controller
- Commissioning resolver motors
- Adjusting the controller settings in a graphical interface
- Extensive diagnostic tools for optimisation and maintenance
- Long-term recording as an aid to assessing operating behaviour
- Archiving all device settings and recordings with export functions for data processing

TLCT manual

The commissioning of a Twin Line unit with the TLCT is described in the "TLCT commissioning software" manual. The manual is included in the software package as a printable PDF file which can be displayed on screen.

Requirements for operation of TLCT

PC or laptop with a free serial port and the Windows 98 operating system or later.

PC and Twin Line unit are connected by the RS232 cable.

Menu structure All commissioning software commands can be executed with the menu items and the program buttons.

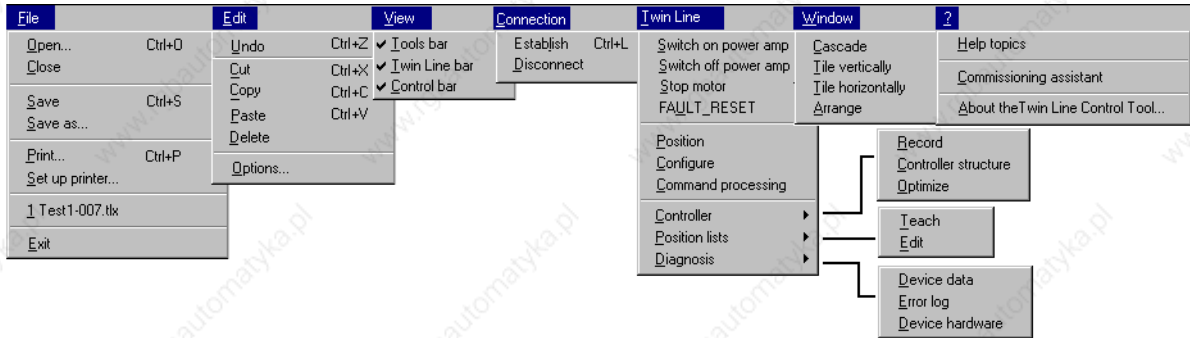

Figure 5.4 The TLCT menu structure

References to a menu item in the software in this manual are always given with the complete menu path, e.g. "Twin Line - Positioning".

Software help The TLCT offers comprehensive help functions, which you can start from the program by pressing "? - Help Topics" or the F1 button.

Commissioning wizard The commissioning wizard will guide you step by step through the commissioning process. Start the wizards with the menu item "? - Commissioning Wizard".



Figure 5.5 Commissioning with the wizards

5.4 Commissioning procedure



WARNING!

Unsuitable parameters may cause injury and damage to the system.

If unsuitable parameters are used, safety functions may fail, unexpected motions or responses to signals may occur.

- Prepare a list with the parameters required for the functions in use.
- Check the parameters before operation.
- Start the system only if there are no persons or materials in the danger zone and the system can be operated safely.

5.4.1 Preparation of controller

Requirements A PC with the TLCT commissioning software or the TLHMI hand-held operating unit must be connected to the controller.

- ▶ The `ENABLE` signal must be set to low level to prevent activation of the motor.
- ▶ Disconnect the connection to the field bus to ensure that the controller cannot be switched on over the Fieldbus.
- ▶ Switch on the external 24 V_{DC} power supply and then the line voltage for the power amplifier.

System check and initialisation The unit carries out a self-test and checks the internal operating data, the parameters, the internal monitoring devices and the connected sensing equipment.

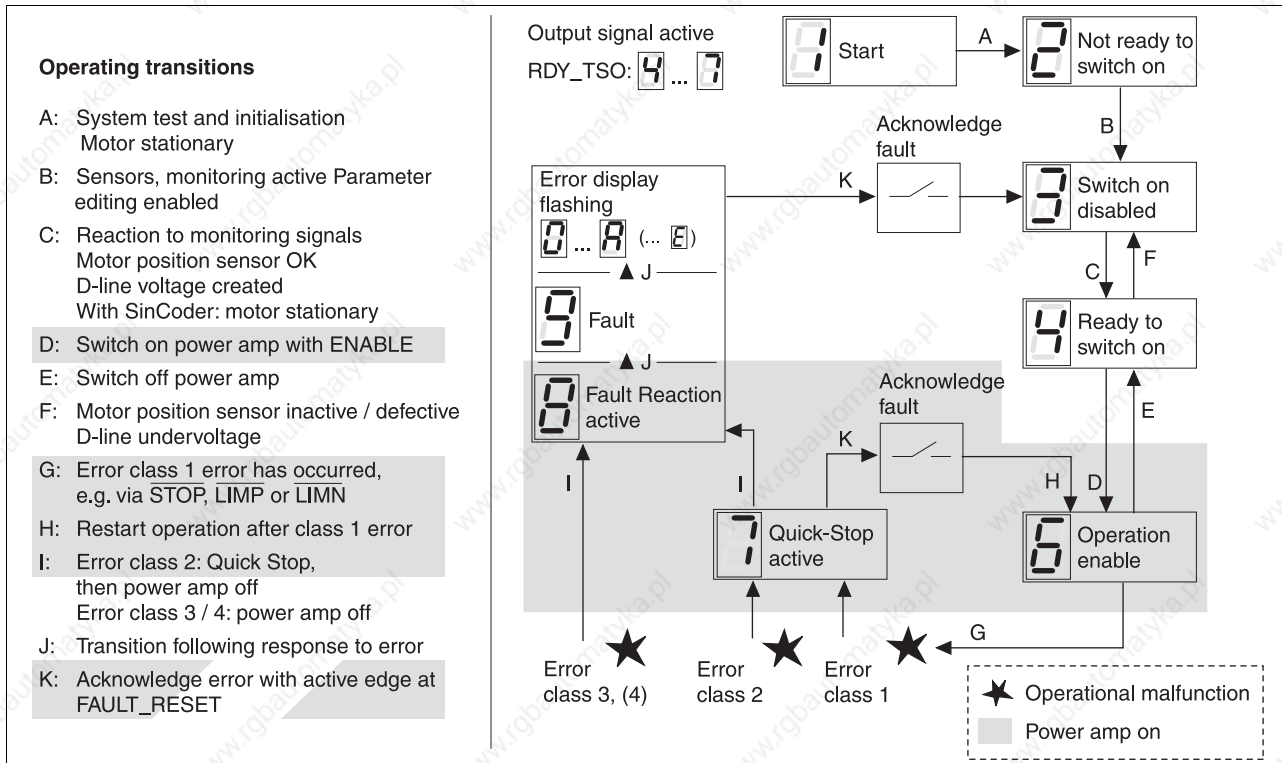

Figure 5.6 Operating states and transitions of the controller

The status display on the controller switches from "1" to "3" or "4".

If the controller remains in status 3, the DC bus voltage is not present or the motor was not detected. For motors with resolvers the motor must be selected with the TLCT. See "Motors with resolver".

If the controller remains in status 4, a motor with a Hiperface interface has been detected. See "Motors with Hiperface interface".

If the display flashes, this indicates a fault. You will find information on rectifying faults in the section entitled 8 "Diagnostics and troubleshooting" from page 8-1

5.4.2 Reading in the motor data



CAUTION!

Prior damage or destruction of the drive!

In the case of resolver motors the controller does not detect whether the loaded motor data match the connected motor. If the incorrect data set is used, the drive system may be damaged or destroyed.

- Compare the motor selected in the data set with the name plate on the motor itself.
- Use only motors with an available data set.

Motor data set

The controller saves a motor data set. This motor data set contains technical information about the motor such as the nominal and peak torque, the nominal current and speed and the pole-pair number. It cannot be modified by the user.

This means that the power amplifier cannot be switched on until the motor data have been loaded.

Motors with Hiperface interface

The operating display shows status "4".

Motor data does not need to be read in for motors with Hiperface sensor. The Hiperface sensor in the motor saves all motor data. The data are automatically read by the controller during startup, saved and sent to the commissioning tool. The controller has checked that the motor data are complete and has established the DC bus voltage.

The controller is correctly installed.

Motors with resolver

The operating display shows status "3".

If a resolver is used as a position encoder, the motor data must be sent to the controller with the TLCT commissioning software before the resolver motor is operated for the first time. The data are saved in the controller and are retained even after replacement of the motor.

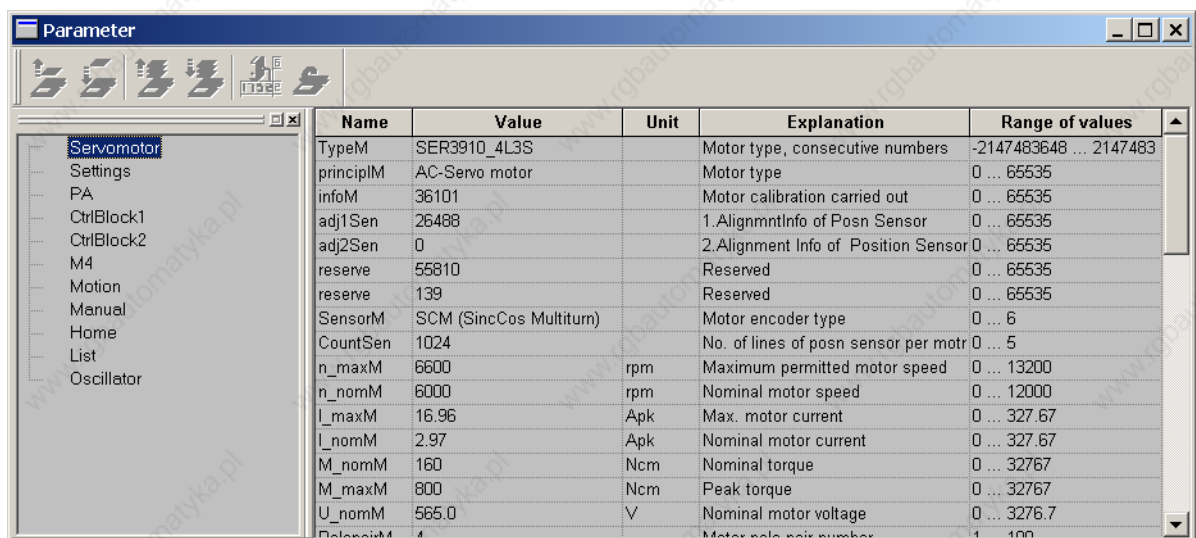

Figure 5.7 Selecting the motor data set

- Selecting the motor data set*
- ▶ Click on the "Parameter" symbol in the fast start bar or select the menu item "Twin Line - Configuration".
 - ◁ The 'Parameters' dialog box will appear.
 - ▶ Click in the parameter group `Servomotor` on the parameter `TypeM`, select the matching motor data set from the list and send the motor parameter set to the device.
 - ◁ The operating display switches to "4".
- The controller is correctly installed.

5.4.3 Checking the signals of limit switches



CAUTION!

Loss of control over controller.

The use of $\overline{\text{LIMP}}$ and $\overline{\text{LIMN}}$ can offer some protection against dangers (e.g. impact on mechanical stop caused by incorrect motion defaults).

- Use $\overline{\text{LIMP}}$ and $\overline{\text{LIMN}}$ where possible.
- Check that the external sensors or switches are correctly connected.
- Check that the external sensors or switches are installed correctly for their function. The braking distance of the drive must not cause damage.
- The functions must be enabled in the controller software to allow $\overline{\text{LIMP}}$ and $\overline{\text{LIMN}}$ to be used.
- This function cannot provide protection against faulty functioning within the controller or the sensors.

► Trigger the limit switches manually and observe the LEDs for the positive limit switch signal $\overline{\text{LIMP}}$ and the negative limit switch signal $\overline{\text{LIMN}}$.

◁ The LEDs remain on unless the limit switches have been tripped.

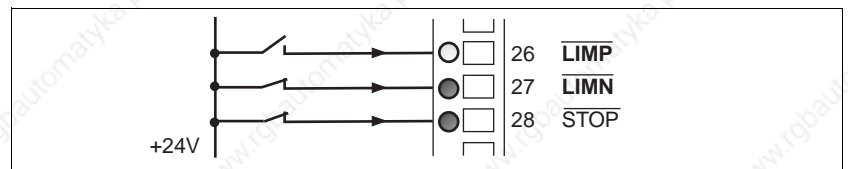

Figure 5.8 Positive limit switch tripped

The input signals $\overline{\text{LIMP}}$, $\overline{\text{LIMN}}$ and $\overline{\text{STOP}}$ and the evaluation to active Low or High can be changed with the parameters `Settings.SignEnabl` and `Settings.SignLevel`, see page 7-30.

The limit switch that limits the working range with positive direction of rotation must be connected to $\overline{\text{LIMP}}$. The limit switch that limits the working range with negative direction of rotation must be connected to $\overline{\text{LIMN}}$.

5.4.4 Checking holding brake



WARNING!

Unexpected motion may cause injury and damage to the system

For example, if the brake is released with vertical axes an unexpected motion may be triggered in the system.

- Make sure that no damage will be caused by the load dropping.
- Run the test only if there are no persons or materials in the danger zone of the moving system components.

Hardware inspection

On IP20 controllers check the brake function of a holding brake with the button on the holding brake controller.

To ensure that the holding brake controller enables the button, it must not be switched by the controller:

- ▶ Disconnect the signal line `ACTIVE_CON` from the controller or switch off the 24 V power supply to the controller.
- ▶ Press the button on the holding brake controller several times to alternately release and re-apply the brake.
- ◁ The LED on the controller will light up when the brake has been activated and thereby released.
- ▶ Check the brake function: the shaft can be moved by hand when the brake is not applied, but not when the brake is applied.

Software inspection

Check the braking function of a holding brake with the TLCT.

- ▶ Open the window "Twin Line - Diagnosis - Device data - Inputs/ outputs".
- ▶ Select 'Force QWO'. Switch the output `ACTIVE` several times to release and close the brake alternately.
- ◁ The LED on the controller will light up when the brake has been activated and thereby released.
- ▶ Check the brake function: the shaft can be moved by hand when the brake is not applied, but not when the brake is applied.

5.4.5 Setting device parameters

Parameter display The parameter view contains information that is required for unique identification of a parameter. The parameter display can also provide information on setting options, presets and parameter properties. It is important to note that the parameters are grouped in functionally related blocks, referred to as parameter groups. A parameter display has the following features:

Group.Name	Idx:Six dec (hex)	TLHMI	Explanation and unit []	Value range	Default value	R/W per.
VEL.velocity	36:1 (24:1 _h)	3.1.2.1	Start of speed change with transfer of setpoint speed [usr]	INT32 -2147483648 ..2147483647	–	R/W-

Group.Name Parameter name consisting of the name of the parameter group ("Group") and the name of the specific parameter ("Name").

Idx Index value of a parameter

Six Subindex value of a parameter

TLHMI Menu item of the 3-level menu structure in the TLHMI that corresponds to a parameter.

Explanation and unit [] Detailed explanation of the parameter and its unit.

Value range In the case of parameters without values the applicable value range depends on the data type.

Data type	Byte	Min value	Max value
INT16	2 Byte / 16 Bit	-32768	32767
UINT16	2 Byte / 16 Bit	0	65535
INT32	4 Byte / 32 Bit	-2.147.483.648	2.147.483.647
UINT32	4 Byte / 32 Bit	0	4.294.967.295

Default values Preset values for the parameters before initial commissioning, factory settings.

R/W Note on reading and writing the values
"R/-" values are read-only
"R/W" values are read and write.

per. Information on whether the value of the parameter is non-volatile, i.e. is retained in memory after switching the unit off. The user must back up the data in the non-volatile memory before switching off the device to ensure that the value is saved in non-volatile memory.

Instructions on input of values:

The values "max.current" and "max.speed" in "value range" correspond to the lower maximum values of power amplifier and motor. The unit limits automatically to the lower value.

Temperatures in Kelvin [K] = temperature in degrees Celsius [°C] + 273
e.g. 358K = 85°C

Use the specifications relevant for controlling the unit through the particular access channel.

Access channel	Specifications
Fieldbus	Idx:Sidx
TLHMI	Menu items under "TLHMI"
TLCT	'Group Name', e.g. Settings.SignEnabl

Note that the value ranges for the different access channels may differ, e.g. value range for `CurrentControl.curr_targ`

- The following applies for control by Fieldbus (=FB):
-32768... +32767 (100=1Apk)
- The following applies for other control (≠FB):
-327.68... +327.67 [Apk].

Selecting the control parameters set

The parameter values of the speed and position controllers are stored in control parameter sets. The controller saves two separate parameter sets, which are initialised on initial commissioning with the factory setting and with values from the motor data set.

The parameter sets are selected in sequence and optimised. The parameter set can be set with the TLHMI hand-held operating unit via the menu item "5.1 SetCtrl", with the commissioning software via the "Parameterset1" button in the toolbar. The controller parameter sets are selected with the parameter `Commands.setCtrl`.

Setting thresholds



WARNING!

Unsuitable parameters may cause injury and damage to the system.

If unsuitable parameters are used, safety functions may fail, unexpected motions or responses to signals may occur.

- Prepare a list with the parameters required for the functions in use.
- Check the parameters before operation.
- Start the system only if there are no persons or materials in the danger zone and the system can be operated safely.

- ▶ Select parameter set 1.
- ▶ Set the thresholds for the following current and speed parameters before you operate the motor in the system. Suitable thresholds must be calculated from the system configuration and motor characteristics. As long as you are running the motor outside the system you will not need to change the default settings.

- ▶ Select parameter set 2 and proceed as in set 1.



CtrlBlock1.I_max specifies the maximum current when optimising the controller.

As long as you are running the motor outside the system you will not need to change the default settings.

A critical parameter could be the maximum motor current, for example, if this causes the permitted torque of a system component to be exceeded. Current limiting must be used to prevent system parts from damage.

Selecting the chopper frequency

The chopper frequency is set with the parameter `Settings.f_Chop`. The lowest possible frequency is the factory preset.

The 24 V power supply must be switched off and on again for the chopper frequency settings to be effective.



When changing the factory setting, note that with the higher chopper frequency the nominal current I_{nomPA} and the maximum current I_{maxPA} are reduced.

Setting ballast resistor controller

If an external ballast resistor controller is connected, the parameter `Settings.TLBRC` must be set to "1".

TLCT: Setting parameters

- ▶ Open the parameter window with "Twin Line - Configuration" and enter the limit values for current and speed.

TLHMI: Setting parameters

- ▶ Input the limit values under the menu items which are shown in the table.

Group.Name	Idx:Six dec (hex)	TLHMI	Explanation and unit []	Value range	Default value	R/W per.
CtrlBlock1.I_max	18:2 (12:2 _h)	4.2.2	Current limitation in all operating modes including controller optimisation. Not in manual and Quick-Stop operating modes (100=1A _{pk})	UINT16 0..max. Current 0..29999	1000	R/W per.
CtrlBlock1.n_max	18:5 (12:5 _h)	4.2.3	Max. speed [rpm]	UINT16 0..'Servomotor.n_maxM' 0..13200	6000	R/W per.
Commands.SetCtrl	28:4 (1C:4 _h)	5.1.0	Switching control parameter sets	UINT16 0: - 1: parameter set 1 2: parameter set 2	0	R/W-
Settings.I_maxSTOP	28:22 (1C:16 _h)	4.1.3	Current limit for quick stop (100=1A _{pk})	UINT16 0..max. Current 0..29999	1000	R/W per.
Manual.I_maxMan	28:25 (1C:19 _h)	3.2.14	Max. current manual movement [100=1A _{pk}]	UINT16 0..Max.current 0..29999	1000	R/W per.
Settings.TL_BRC	28:26 (1C:1A _h)	4.1.14	External ballast resistor controller TLBRC	UINT16 0..1 0: not connected 1: connected	0	R/W per.

0098 441 113 110, V1.00, 07.2004

Group.Name	Idx:Six dec (hex)	TLHMI	Explanation and unit []	Value range	Default value	R/W per.
Settings.f_Chop	12:17 (C:11 _h)	4.1.21	Switching frequency of power module, (default value=1; 0 for TLxx38)	UINT16 0: 4kHz 1: 8kHz 2: 16 kHz,	1	R/W per.

5.4.6 Setting and testing signal interface

The switching states of inputs and outputs of the signal interface can be monitored with the commissioning software or with the hand-held operating unit. The signal states of the inputs and outputs can also be changed with the commissioning software - independent of the hardware signals which are routed through the connections.



WARNING!

Unexpected responses may cause injury and damage to the system

Enabling and disabling inputs and outputs can cause unexpected states and unexpected responses in the system.

- Start the system only if there are no persons or materials in the danger zone and the system can be operated safely.

Parameters for inputs and outputs

The current switching states are displayed in bit-coded form, for the inputs in the parameters I/O.IW0_act and I/O.IW1_act and for the outputs in the parameter I/O.QW0_act. The values 1 and 0 indicate whether an input or output is active.

"0": The input or output carries 0V.

"1": The input or output carries 24V.

Inputs and outputs can be configured with fixed or free signal interface pin assignment. Switching is done with the parameter Settings.IO_mode, see page 6-1.

Bit	Inputs			outputs	
	I/O.IW0_act	I/O.IW1_act fixed assignment	I/O.IW1_act freely assignable	I/O.QW0_act fixed assignment	I/O.QW0_act freely assignable
0	$\overline{\text{LIMP}}$	MAN_P	I_0	Q_0	Q_0
1	$\overline{\text{LIMN}}$	MAN_N	I_1	Q_1	Q_1
2	$\overline{\text{STOP}}$	MAN_FAST	I_2	Q_2	Q_2
3	$\overline{\text{REF}}$	ENABLE	I_3	Q_3	Q_3
4	-	AUTOM	I_4	Q_4	Q_4
5	-	FAULT_RESET	I_5	ACTIVE_CON	ACTIVE_CON
6	-	CAPTURE2	I_6	TRIGGER	TRIGGER
7	-	TEACH_IN	I_7	-	-
8	-	DATA_1	I_8	-	-
9	-	DATA_2	I_9	-	-
10	-	DATA_4	I_10	-	-
11	-	DATA_8	I_11	-	-
12	-	DATA_16	I_12	-	-
13	-	DATA_32	I_13	-	-
14	-	DIG_IN1 ¹⁾	DIG_IN1 ²⁾	DIG_OUT1 ¹⁾	DIG_OUT1 ¹⁾
15	-	DIG_IN2 ¹⁾	DIG_IN2 ¹⁾	DIG_OUT2 ¹⁾	DIG_OUT2 ¹⁾

1) is only assigned if the device has the analogue module IOM-C installed

2) is only assigned if the device has the analogue module IOM-C installed

TLCT: Displaying signal states ▶ Open the dialogue box with the menu item "Twin Line - Diagnosis - Device hardware" and the tab "Inputs/outputs".

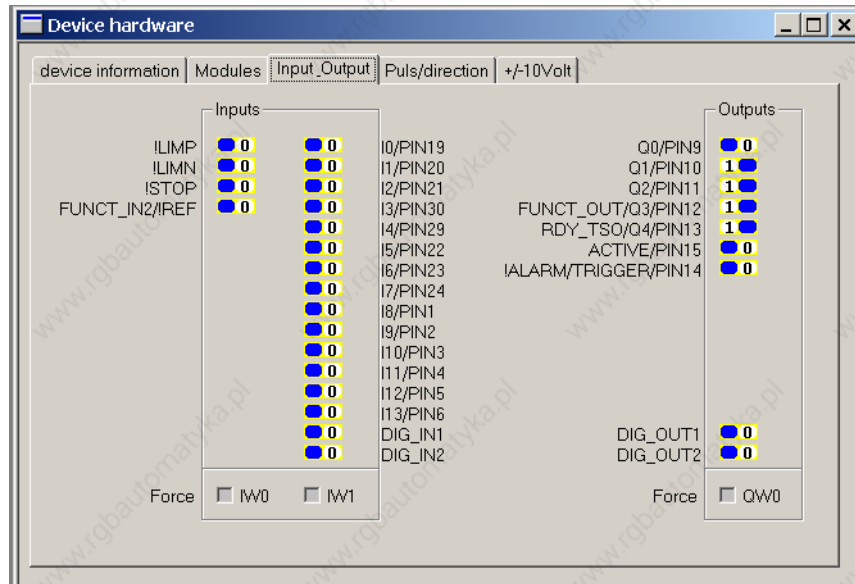

Figure 5.9 Switching the inputs/outputs of the signal interface with the commissioning software



"DIG_IN 1/2" and "DIG_OUT 1/2" are only visible if analogue module is installed at M1.

▶ Activate the 'Force' check box to modify inputs and outputs.



If the PULSE-C module is installed in the controller, you can observe and modify the frequency of the reference values for a setpoint positioning in the "Pulse/direction" tab. The operating function "electronic gearbox" must be enabled for this.

You will find details on displaying and changing signals with the commissioning software in the TLCT manual in the chapter on diagnostic functions.

TLHMI: Displaying signal states ▶ Change to '2.4.1 IW0_act', '2.4.2 IW1_act' or '2.4.10 QW0_act'.

'IW0_act' and 'IW1_act' show the inputs in bit-coded form, 'QW0_act' the outputs.

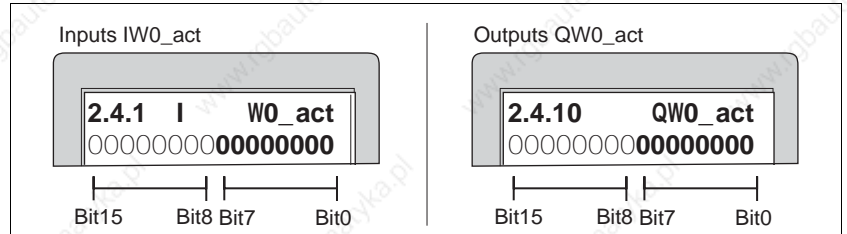

Figure 5.10 Observing inputs/outputs of the signal interface with the TLHMI hand-held operating unit

The TLHMI hand-held operating unit can be used to modify the switching states of input and output signals.

Details on displaying signals with the TLHMI hand-held operating unit can be found in the "TLHMI" manual.

Displaying analogue inputs

The value at the analogue input, pins 17 and 18 of the signal interface, can be displayed by:

- TLHMI
- TLCT
- Fieldbus

TLCT: Displaying analogue input

▶ Open the dialogue box with the menu item "Twin Line - Diagnosis - Device hardware" and the tab "±10Volt".

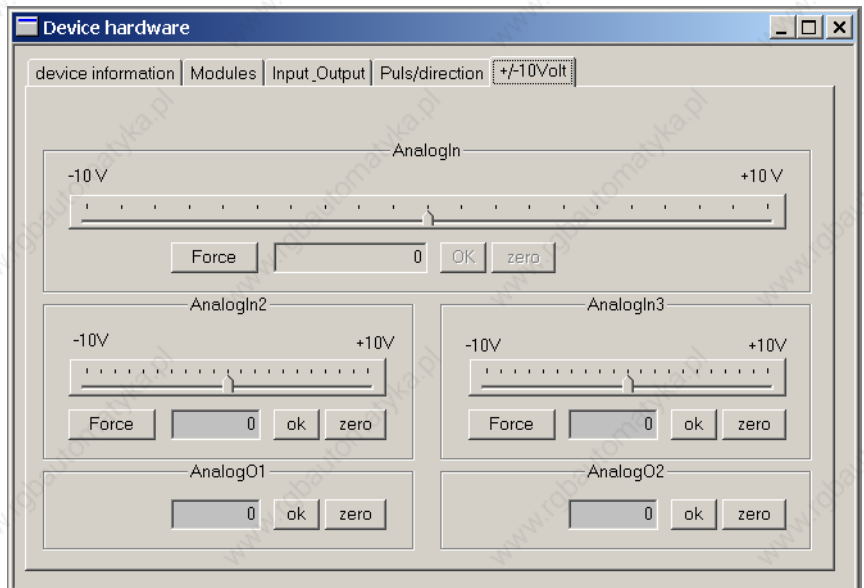

Figure 5.11 Displaying and setting the analogue input with the commissioning software



Operating elements for AnalogIn2/3 and AnalogO1/2 are visible only if the IOM-C analogue module is installed at M1.

- ▶ Switch on the "Force" field to modify the voltage of the analogue input.

You will find details on displaying and changing signals with the commissioning software in the TLCT manual in the chapter on diagnostic functions.

Field bus: Displaying analogue input

- ▶ The analogue input is read and set with the parameter `Status.AnalogIn`.

Group.Name	Idx:Six dec (hex)	TLHMI	Explanation and unit []	Value range	Default value	R/W per.
Status.AnalogIn	20:8 (14:8 _h)	2.3.3.1	analogue input at input ANALOG_IN [mV]	INT16 -10000..+10000	0	R/- -
M1.AnalogIn2	21:14 (15:E _h)	2.3.3.5	voltage value analogue input 2 [mV]	INT16 -10000.. +10000	-	R/- -
M1.AnalogIn3	21:19 (15:13 _h)	2.3.3.6	voltage value analogue input 3 [mV]	INT16 -10000.. +10000	-	R/- -
M1.AnalogO1	21:24 (15:18 _h)	2.3.3.7	Analogue output 1 [mV] (1000=1V) - voltage value from object default - voltage value for current set-point	INT16 -10000 ... +10000	0	R/W-
M1.AnalogO2	21:27 (15:1B _h)	2.3.3.8	Analogue output 2 [mV] (1000=1V) - voltage value from object default - voltage value for setpoint speed value	INT16 -10000.. +10000	0	R/W-

5.4.7 Setting device parameters for rotary encoder

Position processing with SinCos single turn SRS

The value of p_actmodulo may be changed by setting a new absolute position in the SinCos single turn. The position of the virtual index pulse can also be moved in this way (see 6.6.3 "Reference movement with index pulse" on page 6-36. The parameter M2.SetEncPos is available to set a new absolute position.

Group.Name	Idx:Six dec (hex)	TLHMI	Explanation and unit []	Value range	Default value	R/W per.
M2.SetEncPos	22:14 (16:E _n)	–	Setting absolute position in position encoder [Inc]	UINT32 -2147483648..+2147483647 SRS, Sincos-Singleturn: 0 .. 16383 SRM, Sincos.Multiturn: 0 .. 67108863 (=4096*16384-1)	–	R/W per.

Information for setting the absolute position

The value of M2.SetEncPos can be transferred in disable status and also in enable status.

- Transfer the new absolute position value only when the motor is stopped.
- Note that the position displacement only becomes valid after the restart (switch 24 V device power supply off and on). Wait 5 seconds after programming before shutting off the unit.

The position standardisation is not taken into account when setting the position value, because M2.SetEncPos is specified in increments corresponding to the motor resolution.

If the position control is set via M1, the parameter M2.SetEncPos cannot be set.

Position processing with SinCos multiturn SRM

During startup the controller reads the absolute position of the motor from the rotary encoder and sets the actual position.

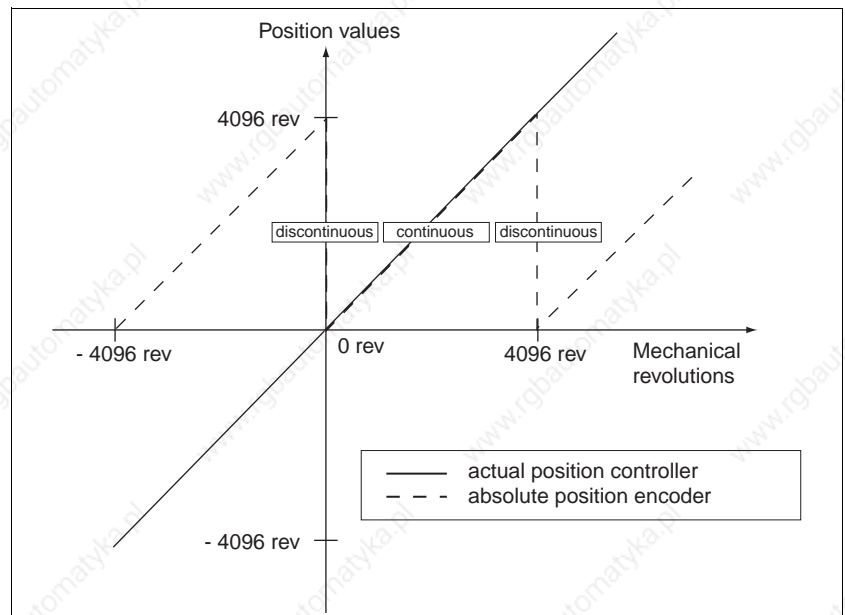

Figure 5.12 Position values without direction reversal

If the motor is moved in the negative direction from the absolute position 0, the SinCos Multiturn detects an underflow of its absolute position. In contrast, the actual position of the controller continues to count mathematically and shows a negative position value.

After switching it off and on again the actual position would no longer show the negative position value but would accept the absolute position of the SinCos Multiturn.

To prevent these jumps through underflow or overrun, i.e. discontinuous positions in the movement range, the absolute position must be set in the encoder so the mechanical limits are inside the continuous range of the encoder.

TLCT: Setting absolute position in position encoder

- ▶ Open the parameter window with "Twin Line - Diagnosis - Device hardware - SinCos"



Figure 5.13 Set the absolute position in the position encoder by M2 . SetEncPos

Group.Name	Idx:Six dec (hex)	TLHMI	Explanation and unit []	Value range	Default value	R/W per.
M2.SetEncPos	22:14 (16:EH)	–	Setting absolute position in position encoder [Inc]	UINT32 -2147483648..+2147483647 SRS, Sincos-Singleturn: 0 .. 16383 SRM, Sincos.Multiturn: 0 .. 67108863 (=4096*16384-1)	–	R/W per.

- ▶ Enter a position value >0. This ensures that when the drive is moved within the mechanical limits of the system the resulting sensor position is always within the continuous range of the sensor.
- ▶ Note that the absolute position is stored in the SinCos multiturn, so the settings remain when the TL unit is replaced.



The direction of rotation reversal must be specified before setting the absolute position in the position encoder (see Chapter 7.8 "Reversal of direction of rotation" on page 7-26).

5.4.8 Test mode of motor with manual movement



WARNING!

Unexpected motion may cause injury and damage to the system

When the drive is operated for the first time there is a high risk of unexpected motion because of possible wiring faults or unsuitable parameters.

- If possible, run the first test movement without coupled loads.
- Make sure that a functioning button for EMERGENCY STOP is within reach.
- Also anticipate a movement in the incorrect direction or oscillation of the drive.
- Make sure that the system is free and ready for the motion before starting the function.

Operating options

The controller is supplied with a controller preset that allows the operation to be tested with a manual movement.

The test operation with manual movement can be executed with the TLCT commissioning software, the TLHMI hand-held operating unit over the signal interface.

If you wish to run the Twin Line unit with the fixed preset signal interface assignment, run the test movement via the signal interface. Set the parameter `Settings.IO_mode` to 2.

Direction of rotation

Rotation of the motor shaft in a clockwise or counterclockwise direction. A clockwise direction of rotation is given when the motor shaft rotates clockwise as the observer faces the end of the protruding shaft. This is the positive direction of rotation.

Group.Name	Idx:Six dec (hex)	TLHMI	Explanation and unit []	Value range	Default value	R/W per.
Settings.IO_mode	29:31 (1D:1F _h)	4.1.4	Significance of I/O signal assignment	UINT16 0..2 0: settings of field bus parameter via I/O assignment 1: I/O freely available 2: I/O assigned with function	0	R/W per.
Motion.invertDir	28:6 (1C:6 _h)	4.4.27	Inversion of sense of rotation	UINT16 0..2 0: no inversion 1: direction inversion function Mode1: after controller startup the current encoder value is inverted 2: direction inversion function Mode2: after controller startup the current encoder value is not inverted (only motors with Multiturn rotary encoder)	0	R/W per.

Limit switch If limit switches or stop switches are not connected, the $\overline{\text{LIMP}}$, $\overline{\text{LIMN}}$ or $\overline{\text{STOP}}$ signals must be powered with +24 V.

- Manual movement with TL HMI*
- ▶ Start a manual movement with the TLHMI from the menu "3.2.11 Start". Use the arrow keys to check the direction of rotation.
 - ▶ Check the direction of rotation: The motor shaft must rotate clockwise when the right arrow is pressed.

If the direction of rotation is not correct, use the parameter `Motion.invertDir` to correct the direction of rotation. Do not reverse the motor phases.

For details on manual movement with the HMI hand-held unit see the TL HMI manual.

- Manual movement with TL CT*
- ▶ Enable the power amplifier with the menu item "Twin Line - Switch on power amplifier".
 - ◀ The operational status indicator changes to '6'.
 - ▶ Open the "Positioning" dialogue box with "Twin Line - Positioning" and start the manual movement with the "Manual" tab.
 - ▶ Click on one of the two "right" buttons for the motor to rotate clockwise.
 - ▶ Check the direction of rotation: The motor shaft must rotate clockwise when one of the "Motor clockwise" keys is pressed.

If the direction of rotation is not correct, use the parameter `Motion.invertDir` to correct the direction of rotation. Do not reverse the motor phases.

For details on manual movement with the commissioning software see the TLCT manual.

Manual movement via the signal interface The parameter `Settings.IO_mode` must be set to 2 for the manual movement via the signal interface. The following signals must be switched.

I/O signal	Value	Function
MAN_N	stop motor movement anticlockwise	0 / open 1
MAN_P	stop motor movement clockwise	0 / open 1
$\overline{\text{STOP}}$ ¹⁾	stop motor with Quick-Stop operation enable	0 / open 1
AUTOM	manual mode automatic mode	0 / open 1
ENABLE	power amplifier switched off power amplifier enabled	0 / open 1

1) signal level at default setting of parameter "Settings.SignEnabl" and "Settings.SignLevel"

- ▶ Switch on manual mode: Deactivate AUTOM input signal.
- ▶ Switch on power amplifier: Enable ENABLE input signal.

- ▶ Rotate motor shaft clockwise: Enable MAN_P input signal.

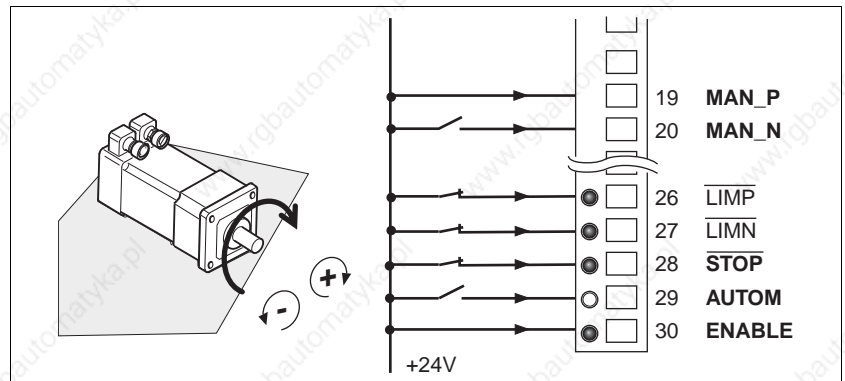

Figure 5.14 Check direction of rotation

If the signal `MAN_FAST` is connected, you can switch between fast and slow movement mode.

For the manual movement the default motion parameters can be modified for slow and fast motor speed for the maximum motor current, see page 6-10.

5.5 Optimising the controller

5.5.1 Controller structure

The controller structure in the controller corresponds to the classical cascade control of a position control loop with current controller, speed controller and position controller. The reference value of the speed controller can also be smoothed by an upstream filter.

The controllers are set one after the other from the 'inside' to the 'outside' in the sequence current, speed, and position controller. The higher-level control loop in each case stays switched out.

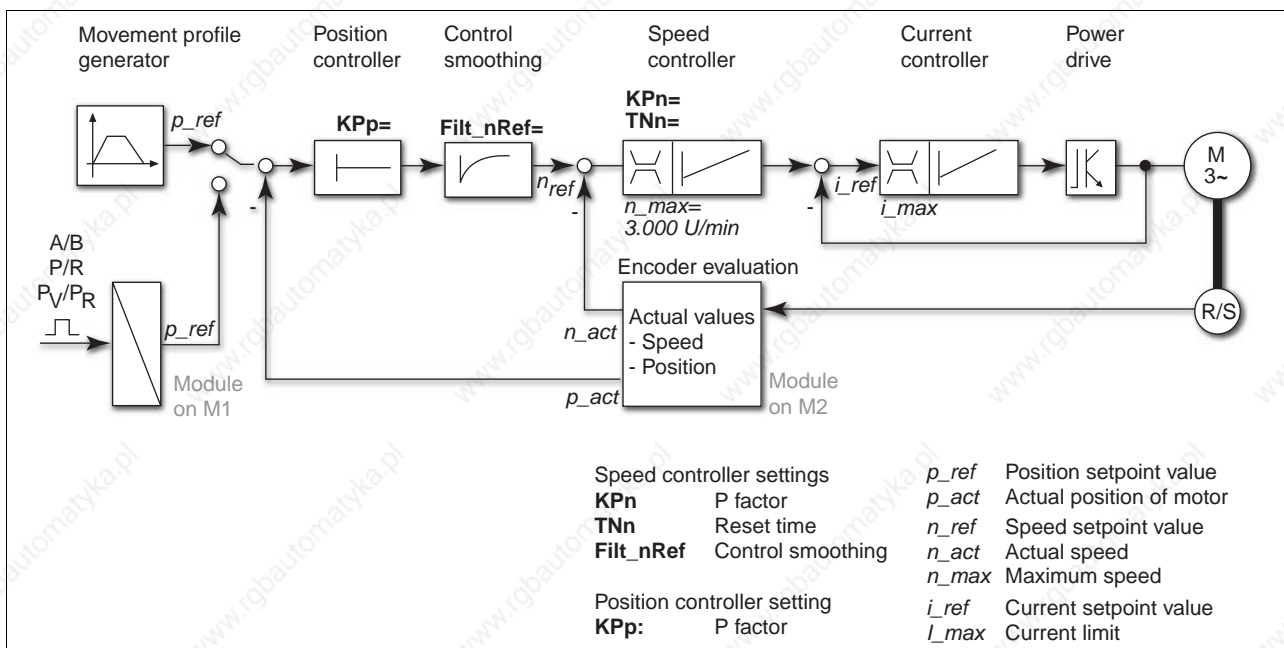

Figure 5.15 Controller structure for encoder evaluation via M2 module

Position control via M1 (special case)

If an additional encoder separated from the motor (e.g. a glass scale), which must be connected with a RS422-C module on M1, is used, the position can be measured directly after activation. This means that the additional encoder is used as the actual position encoder instead of the encoder linked through M2. The commutation position and the actual speed are also calculated with the resolver or the Hiperface incremental encoder via M2.

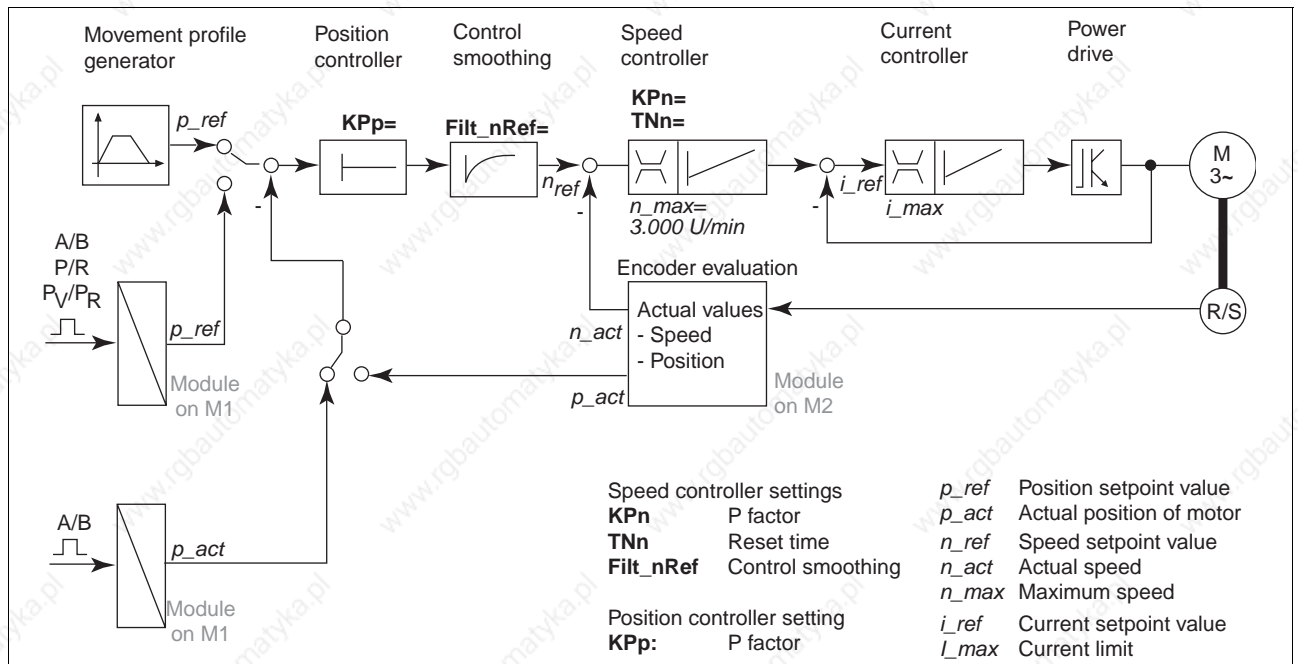

Figure 5.16 Controller structure for encoder evaluation via M1 module



Because the controller structure for encoder evaluation via module M1 is only used in exceptional cases, the following information generally refers to encoder evaluation via module M2.

Current controller

The motor's drive torque is determined by the current controller. The current controller has been optimised using the stored motor data.

Speed controller

The speed controller exerts a decisive influence on the speed with which the drive reacts. The dynamics of the speed controller depend on

- the moments of inertia of the drive
- the torque of the motor
- Stiffness and elasticity of the elements in the power flow
- the play of the mechanical drive elements
- the friction

Position controller

The position controller reduces the following error to zero. The setpoint position for the position control loop is generated by the travel profile generator.

A requirement for good gain of the position controller is an optimised speed control loop.

5.5.2 Configuring the optimisation utility

The optimisation tool is used to adapt the controller for the operating conditions in the system. The tool is available with the hand-held operating unit with the commissioning software. Some functions are:

- Selecting the control loops, higher-order control loops are switched off automatically.
- Defining reference signals: signal form, height, frequency and starting point.
- Testing control response with the signal generator.
- Displaying the control response on the screen and assessing it with the commissioning software.

Controller optimisation can only be started in manual mode:

- ▶ If the parameter `Settings.IO_Mode = 2`, the signal `AUTOM` must be set to low level over the signal interface.
- ▶ Start the tool for optimisation from the menu item "Twin Line - Controller - Optimise".

TLCT: Setting reference signals

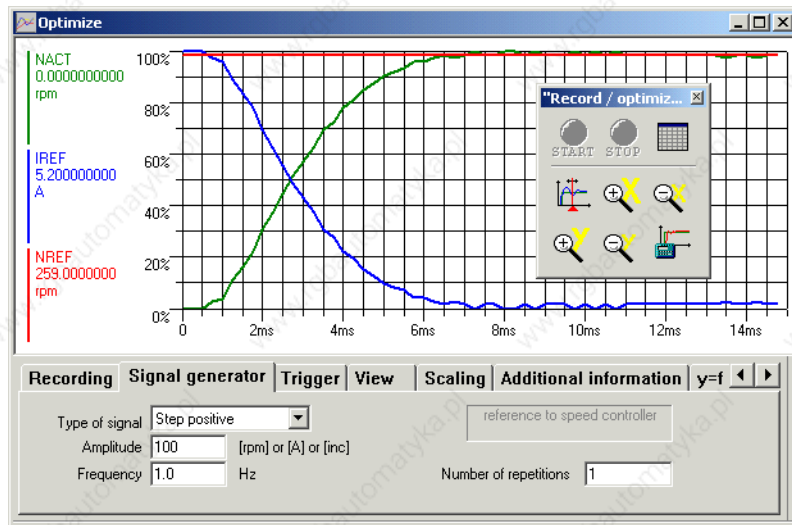

Figure 5.17 Optimising with the commissioning software

The window shows a graphic display of the signal paths of the reference signal and the responses of the controller. Up to four response signals can be transmitted and displayed simultaneously. The utility is configured via the tabs.

- ▶ Select the tab 'Reference variable' to set the values for the reference signal:
 - Signal form: 'Positive jump'
 - Amplitude: 100 rpm
 - Frequency: 1 Hz
 - Number of repetitions: 1.

0098 441 113 110, V1.00, 07.2004



The total dynamic behaviour of a control loop can be only understood with the signal forms 'Jump' and 'Square wave'. Refer to the manual for all signal paths for the signal form 'Jump'.

TLCT: Setting recording signals

- ▶ Select the 'Recording' tab to set the signals and default values for diagram evaluation:
 - Use the 'select recording values' tab to select the signals which are to be displayed as a jump response from the control loop:
 - Actual speed of the motor 'n_act'
 - setpoint speed of the speed encoder 'n_ref'
 - Setpoint current of the current controller 'I_ref'
 - In the 'Timebase' field: 1 ms
 - In the 'Recording type' field: Speed controller. The speed controller is optimised first.
 - In the 'Measurements' field: 100, measured data are recorded for 100*1 ms.
 - The 'Long-term measurement' and 'Loop' fields remain switched off.

Under the 'View' tab you can still modify the default values for the diagrammatic presentation of the individual signals. The remaining tabs can be left at the default settings for optimisation of the controller.

Inputting controller values

Control parameters must also be input for the individual optimisation steps described over the following pages. These parameters must be tested by initiating a jump function.

A jump function is initiated immediately after you start a recording in the 'Optimise window by hitting the button on the tool bar.

You can enter controller values for optimisation in the parameters window in the group 'CtrlBlock1' or 'CtrlBlock2'. Select parameter set 1 if the first parameter set is enabled.

Controller optimisation algorithm

The algorithm for controller optimisation enables the commissioning software to optimise the controller automatically. When the user calls up the algorithm, it determines the optimum parameter set for the connected motor-controller combination.

Optimisation is carried out by approximation using the aperiodic limiting case method. Theoretical controller settings are calculated based on an estimated value for the total moment of inertia.

HMI: Setting reference signals

- ▶ Start the optimisation utility with the '6 Optimise menu.
- ▶ Set the reference signal:
 - Signal form 'Jump' under '6.1.1 Ref_Typ': 1
 - Repeat frequency under '6.1.2 Ref_Frequ': 1 Hz
 - Amplitude under '6.1.3 Amplitude': 100 rpm
 - Number of repetitions (cycles) under '6.1.4 CycleCnt': 1.

HMI: Setting controller values

Control parameters must also be input for the individual optimisation steps described over the following pages. These parameters must be tested by initiating a jump function.

You can enter controller values for optimising the speed controller under '6.2 Speed contr.'. The speed controller is optimised first.

After a controller value is entered the HMI hand-held unit will ask whether a jump function should be started using the value which has been entered. Confirm by pressing Enter, cancel by pressing Esc.

You cannot carry out recordings with the HMI hand-held unit.

5.5.3 Optimising the speed controller

The optimum setting for complex mechanical control systems requires practical experience with setting and adjustment procedures for control equipment. This includes the ability to calculate control parameters and to apply identification procedures.

Mechanical systems of a lower level of complexity can usually be optimised successfully with one of the three following experimental setting procedures:

- Procedure A: Setting with a rigid mechanism with a known and constant load inertia
- Procedure B: Setting as per Ziegler Nichols
- Procedure C: Setting using the aperiodic limiting case method.

Here the following two parameters are set:

Group.Name	Idx:Six dec (hex)	TLHMI	Explanation and unit []	Value range	Default value	R/W per.
CtrlBlock1.KPn	18:7 (12:7 _h)	4.2.5 6.2.1	Speed controller P-factor [10000=1A*min/rev]	UINT16 0..32767	10	R/W per.
CtrlBlock1.TNn	18:8 (12:8 _h)	4.2.6 6.2.2	Speed controller correction time I-factor (100=1ms)	UINT16 26..32767	500	R/W per.

In the next step check and optimise the values obtained, as described in 5.5.7 "Checking and optimising default settings" from page 5-39.

Determining the mechanics of the system

Decide which one of the following two systems fits the mechanics of your set-up to assess and optimise its response behaviour.

- System with rigid mechanism
- System with less rigid mechanism

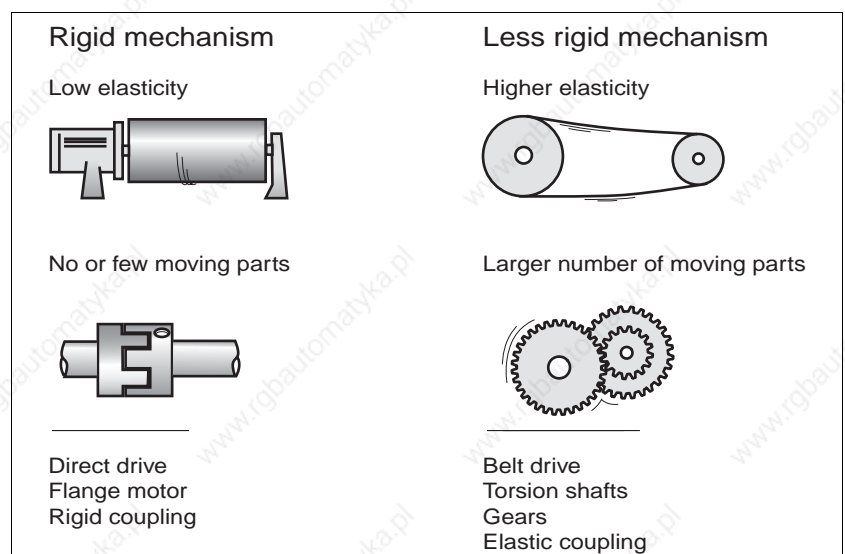

Figure 5.18 Mechanical systems with rigid and less rigid mechanisms

- ▶ Connect the motor to your system's mechanism.



WARNING!

Unexpected motion may cause injury and damage to the system

The jump function moves the motor in speed mode at constant speed until the specified time has expired.

- Check that the selected values for speed and time do not exceed the available distance.
 - If possible, use limit switches or stop as well.
 - Make sure that a functioning button for EMERGENCY STOP is within reach.
 - Make sure that the system is free and ready for motion before starting the function.
- ▶ Carry out a function check of the limit switches once the motor has been installed. The LEDs for the limit switch signals on the controller must be on. Trigger the limit switch manually so the LEDs of the limit switch signals are switched off for a moment.

Switching off the reference variable filter

With the reference variable filter you can improve the response behaviour under optimised speed control. The filter must be switched off when setting the speed controller for the first time.

- ▶ Deactivate the reference variable filter. Set the filter time constant 'Filt_nRef' to the lower threshold value 0.

Group.Name	Idx:Six dec (hex)	TLHMI	Explanation and unit []	Value range	Default value	R/W per.
CtrlBlock1.Filt_nRef	18:20 (12:14 _h)	4.2.8	Filter time constant reference variable filter of the setpoint speed (100=1ms)	UINT16 0..32767	0	R/W per.

5.5.4 Procedure A: Rigid mechanism and known moments of inertia

Requirements for setting the control response as per the table are

- a known and constant inertia of load and motor
- a rigid mechanism

Determining controller values

The P-factor `CtrlBlock1.KPn` and the correction time `CtrlBlock1.TNn` depend on the inertia of the motor and the external inertia.

- ▶ Determine the values with the aid of the following table.

J_L : Moment of inertia of the load

J_M : Mass moment of inertia of the motor

J_L [kgcm ²]	$J_L = J_M$		$J_L = 5 * J_M$		$J_L = 10 * J_M$	
	KPn	TNn	KPn	TNn	KPn	TNn
1	0.0125	8	0.008	12	0.007	16
2	0.0250	8	0.015	12	0.014	16
5	0.0625	8	0.038	12	0.034	16
10	0.125	8	0.075	12	0.069	16
20	0.250	8	0.150	12	0.138	16



WARNING!

Unexpected motion may cause injury and damage to the system

The jump function moves the motor in speed mode at constant speed until the specified time has expired.

- Check that the selected values for speed and time do not exceed the available distance.
- If possible, use limit switches or stop as well.
- Make sure that a functioning button for EMERGENCY STOP is within reach.
- Make sure that the system is free and ready for motion before starting the function.

- ▶ Initiate a jump function.

- ▶ Check the controller settings in accordance with the information in 5.5.7 "Checking and optimising default settings" from page 5-39.

If oscillations occur with the setting values obtained from the table, this indicates that the mechanism is not rigid enough. In this case use Procedure C 'Aperiodic limiting case' for the default settings of the controller values.

5.5.5 Procedure B: Ziegler Nichols



CAUTION!

Oscillation can damage the system.

Using this procedure for setting the controller induces short-term oscillations in the drive and the mechanical systems. In critical situations this can damage the system.

- Do not use this method if the system tends to oscillate strongly.
- Do not use this method if the system could be damaged by oscillation.

The requirement for determining the setting values by Ziegler Nichols is that the speed controller can be operated for a short time in the unstable range.

Determining controller values

For optimisation the critical gain of the speed controller must be determined:

- ▶ Set the correction time `CtrlBlock1.TNn` to infinite: `TNn=327.67 ms`.

If a load torque is acting on the stationary motor, the correction time "TNn" must be set just high enough to prevent an uncontrolled change of the motor position.



In drive systems in which the motor is loaded while stationary, e.g. with vertical axis operation, the correction time "infinite" may result in unwanted position deviations, thereby requiring the value to be reduced. However, this can adversely affect optimisation results.



WARNING!

Unexpected motion may cause injury and damage to the system

The jump function moves the motor in speed mode at constant speed until the specified time has expired.

- Check that the selected values for speed and time do not exceed the available distance.
 - If possible, use limit switches or stop as well.
 - Make sure that a functioning button for EMERGENCY STOP is within reach.
 - Make sure that the system is free and ready for motion before starting the function.
- ▶ Initiate a jump function.
 - ▶ After the first test check the maximum amplitude for the current set-point 'I_ref'. In the TLCT you can click on the graph below the high-

est point on the curve for "I_ref" and read the value in the legend for the graph.

Set the amplitude of the reference value – default was 100 rpm – just high enough so the current setpoint "I_ref" remains below the maximum value `CtrlBlock1.I_max`. On the other hand, the value selected should not be too low, otherwise friction effects of the mechanism will determine control loop response.

- ▶ Trigger a jump function again if you need to modify "n_ref" and check the amplitude of "I_ref".
- ▶ Increase the P-factor in small steps until 'n_act' reacts with a marked oscillation. The P-factor is now the same as the critical gain.

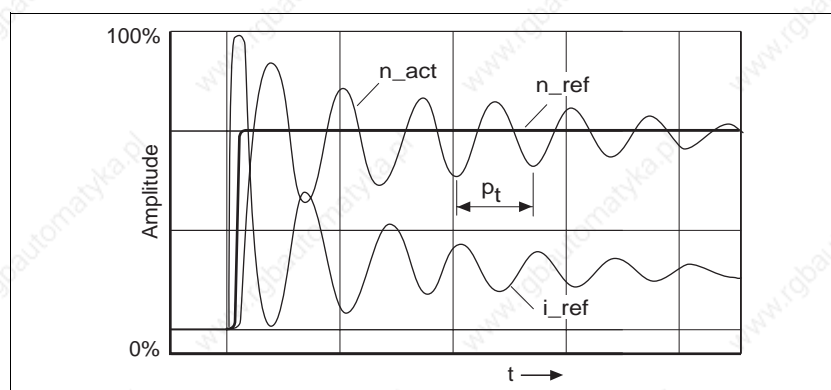

Figure 5.19 Period of oscillation P_t at critical gain

- ▶ Measure the period of oscillation P_t . Set a reference point at the start of the measuring distance and click on the end point of the period. The difference in ms now appears under 'DIFF' on the status bar.
- ▶ Use the following formula to calculate the optimised setting for the P-factor 'KPn' and reset time 'TNn':

$$KPn = 0.35 * \text{critical gain.}$$

$$TNn = 0.94 * \text{period of oscillation } P_t$$
- ▶ Enter the optimised values and check the controller settings as described in 5.5.7 "Checking and optimising default settings" from page 5-39.

Example

- Start with
 - $KPn = 0.0001 \text{ Amin/rev}$
 - $TNn = 327.67 \text{ ms.}$
- Increase the KPn to critical gain.
- Critical gain at $KPn = 0.048 \text{ Amin/rev}$, measured period of oscillation $P_t = 3 \text{ ms.}$
- From this the optimised values are calculated:
 - $KPn = 0.35 * 0.048 \text{ Amin/rev} = 0.0168 \text{ Amin/rev}$
 - $TNn = 0.94 * 3 \text{ ms} = 2.82 \text{ ms.}$

5.5.6 Procedure C: Aperiodic limiting case

Determining controller values

For optimisation purposes the P-factor of the speed controller at which the controller adjusts the speed 'n_act' as quickly as possible without overshooting is determined.

- ▶ Set the correction time `CtrlBlock1.TNn` to infinite
TNn = 327.67 ms.

If a load torque is acting on the stationary motor, the correction time "TNn" must be set just high enough to prevent an uncontrolled change of the motor position.



In drive systems in which the motor is loaded while stationary, e.g. with vertical axis operation, the correction time "infinite" may result in unwanted position deviations, thereby requiring the value to be reduced. However, this can adversely affect optimisation results.



WARNING!

Unexpected motion may cause injury and damage to the system

The jump function moves the motor in speed mode at constant speed until the specified time has expired.

- Check that the selected values for speed and time do not exceed the available distance.
- If possible, use limit switches or stop as well.
- Make sure that a functioning button for EMERGENCY STOP is within reach.
- Make sure that the system is free and ready for motion before starting the function.

- ▶ Initiate a jump function.

- ▶ After the first test check the maximum amplitude for the current setpoint 'I_ref'. In the commissioning software you can click on the graph below the highest point on the curve for "I_ref" and read the value in the legend for the graph.

Set the amplitude of the reference value – default was 100 rpm – just high enough so the current setpoint "I_ref" remains below the maximum value `CtrlBlock1.I_max`. On the other hand, the value selected should not be too low, otherwise friction effects of the mechanism will determine control loop response.

- ▶ Trigger a jump function again if you need to modify "n_ref" and check the amplitude of "I_ref".
- ▶ Increase or decrease the P-factor in small steps until 'n_act' adjusts as fast as possible. The following diagram shows the adjustment response required on the left. Overshooting - as shown on the right - is reduced by reducing the 'KPn' value.

Deviations from 'n_ref' and 'n_act' result from setting 'TNn' to 'Infinite'.

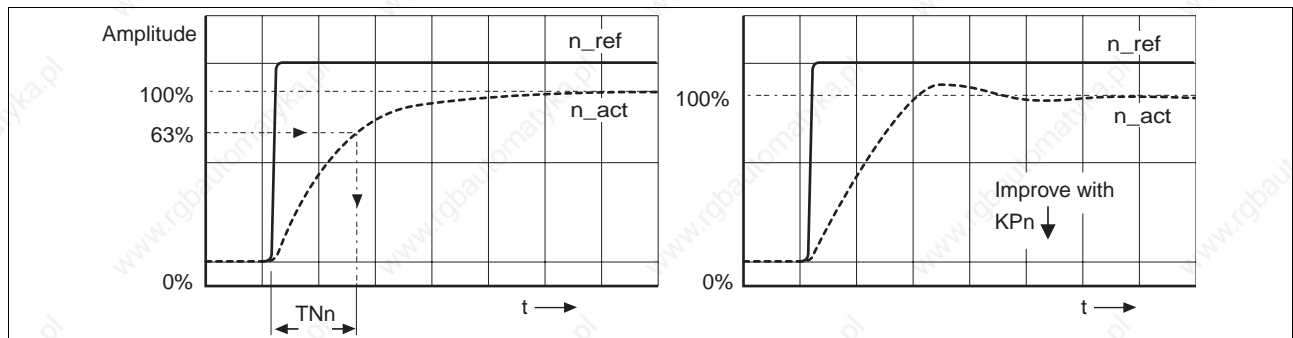

Figure 5.20 Determining 'TNn' in the aperiodic limiting case



For drive systems in which oscillations occur before the aperiodic limiting case is reached, the P-factor "KPn" must be reduced to the exact point where oscillations can no longer be detected. This occurs frequently with linear axes with a toothed belt drive.

Graphical calculation of the 63% value

Determine graphically the point at which the actual speed 'n_act' reaches 63% of the final value. The reset time 'TNn' is then shown as a value on the time axis. The commissioning software will help you with evaluation:

- ▶ Under the 'Scaling' tab select the channel for 'n_act' and enter the final value of 'n_act' as the 100% mark.
- ▶ Now read the 63% amplitude value directly from the diagram and click on the 63% point on the 'n_act' curve.
- ▶ If 'n_ref' starts at 0 ms, you can read the time value for 'TNn' directly off the status bar under 'ABS'.

If 'n_ref' starts later, you will need to measure the distance from the starting point: Set a reference point at the start of the measuring distance and click on the end point. The difference in ms now appears under 'DIFF' on the status bar.

- ▶ Enter this value for 'TNn' and check the controller settings as described in 5.5.7 "Checking and optimising default settings" from page 5-39.

Graphical calculation of the 63% value

Determine graphically the point at which the actual speed 'n_act' reaches 63% of the final value. The reset time 'TNn' is then shown as a value on the time axis. The commissioning software will help you with evaluation:

- ▶ Under the 'Scaling' tab select the channel for 'n_act' and enter the final value of 'n_act' as the 100% mark.
- ▶ Now read the 63% amplitude value directly from the diagram and click on the 63% point on the 'n_act' curve.
- ▶ If 'n_ref' starts at 0 ms, you can read the time value for 'TNn' directly off the status bar under 'ABS'.

If 'n_ref' starts later, you will need to measure the distance from the starting point: Set a reference point at the start of the measuring distance and click on the end point. The difference in ms now appears under 'DIFF' on the status bar.

- ▶ Enter this value for 'TNn' and check the controller settings as described in 5.5.7 "Checking and optimising default settings" from page 5-39.

5.5.7 Checking and optimising default settings

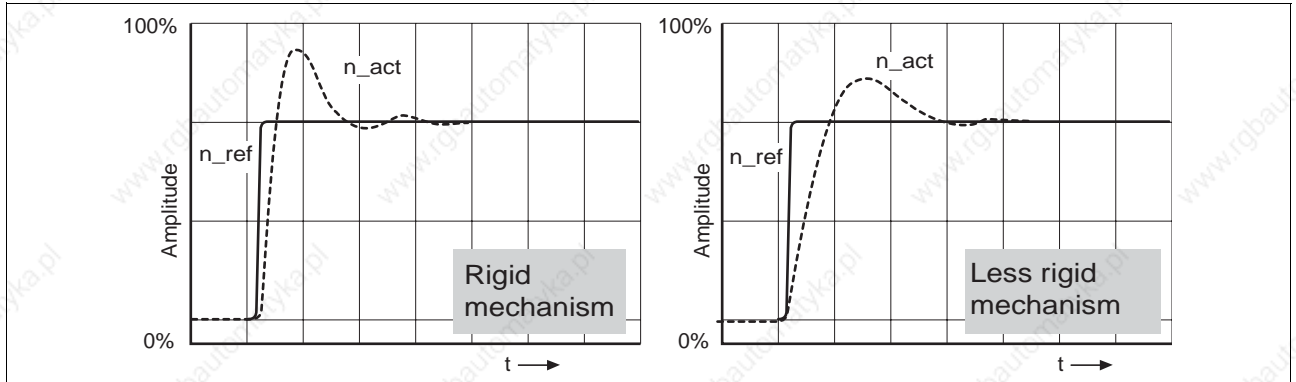

Figure 5.21 Jump responses with good control response without reference smoothing

The controller is properly set when the jump response is approximately identical to the signal path shown. Good control response can be recognised by

- Fast adjustment
- Overshooting up to a maximum of 40% - 20% is recommended.

If the control response does not correspond to the curve shown, change 'KPn' in steps of about 10% and then initiate a jump function once again:

- If the controller is too slow: increase 'KPn'.
- If the controller tends to oscillate: decrease 'KPn'.

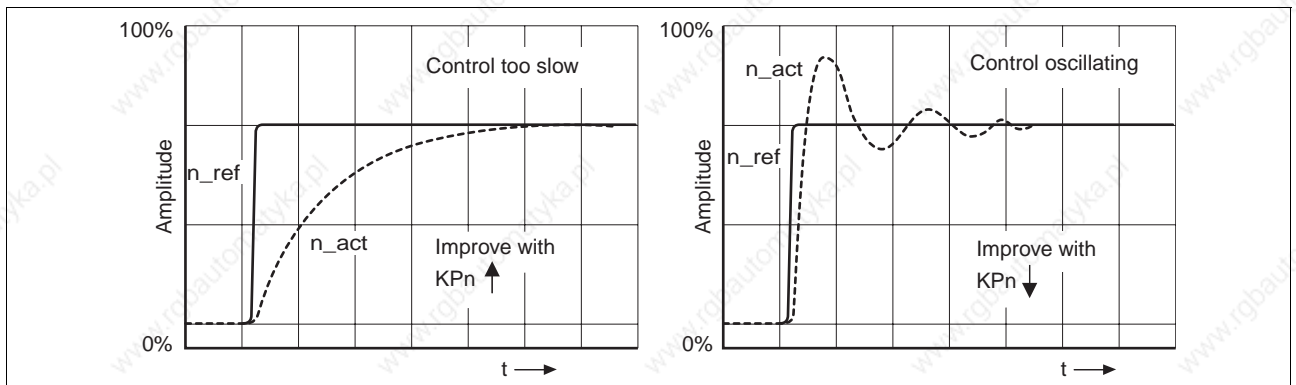

Figure 5.22 Optimising poor speed controller settings



If the motor hunts in spite of factory setting or, in the case of systems with a less rigid mechanism, it is impossible to achieve a satisfactory control response with the values "KPn" and "TNn", the settings in the controller must be adapted to the system. Contact your local dealer; the controller must be adapted to the specific case. Hunting can be detected when the motor speed oscillates strongly after the start phase and the motor continuously accelerates and decelerates.

Effect of the reference variable filter on control response and stability

When the control response is good, you can further reduce overshooting of the jump response by using the reference variable filter. However, this setting is only recommended in systems with a rigid mechanism. The filter enables a higher control response, but the stability of the mechanics may be reduced, rendering the system prone to oscillations.

- Control response: the speed at which the actual value follows the setpoint value
- Stability: the tendency of the actual value to fluctuate. Fewer oscillations mean good stability.

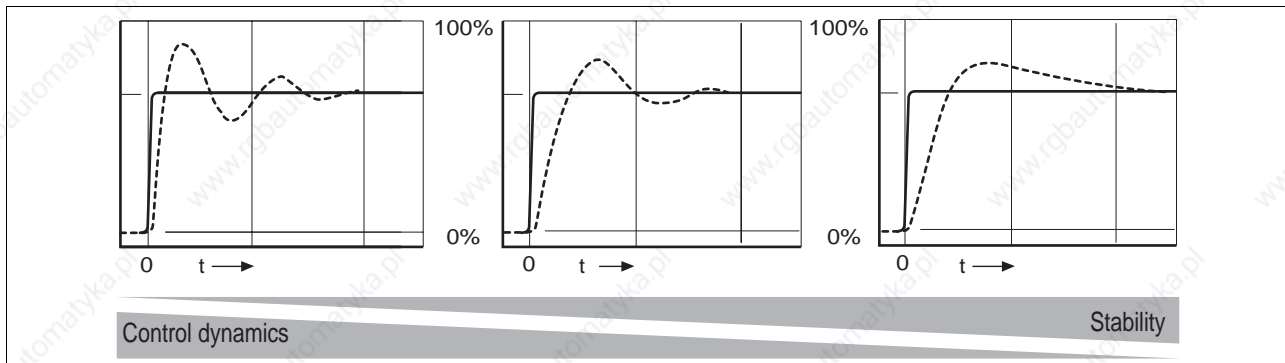

Figure 5.23 Relationship of control response and stability

Switching on the reference variable filter

Determine graphically the point at which the actual speed 'n_act' reaches 63% of the final value. The filter value 'Filt_nRef' may be read on the time axis as shown in the left-hand part of the following diagram. The method for graphically determining the value is described on page 5-37 for the reset time 'TNn'.

- ▶ Set the value `CtrlBlock1.Filt_nRef` to the calculated time value.
- ▶ Start a jump function with an amplitude of 10% of the maximum speed value.

With a less rigid mechanism overshooting may actually get worse. In such a case, reset the value 'Filt_nRef' to its original value.

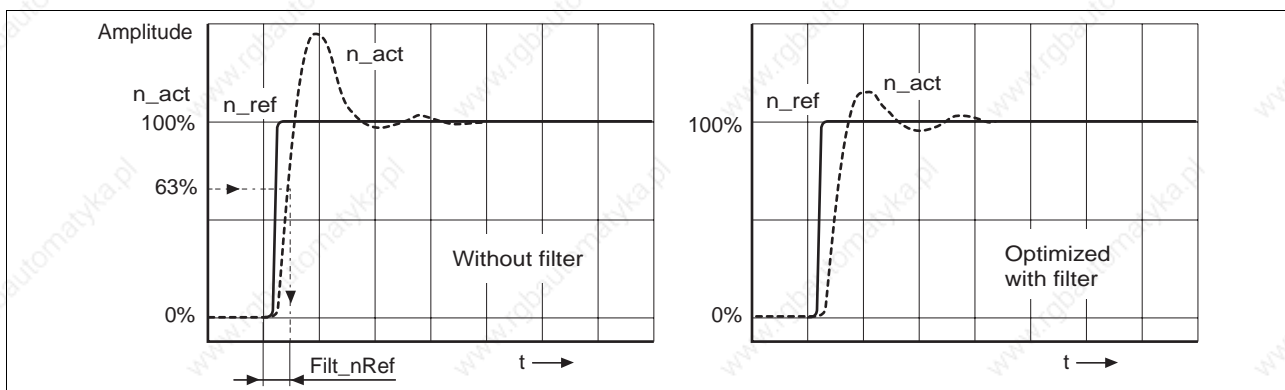

Figure 5.24 Determining Filt_nRef and the jump response with reference variable filter with good control response

5.5.8 Optimising the position controller

Optimisation requires a good control response in the lower-ranking speed control circuit.

When setting the position control the P-factor of the position controller "KpP" must be optimised in two limits:

- 'KpP' too high: overshooting of the mechanism, instability of the controller
- 'KpP' too low: Large following error

Group.Name	Idx:Six dec (hex)	TLHMI	Explanation and unit []	Value range	Default value	R/W per.
CtrlBlock1.KpP	18:15 (12:F _h)	4.2.10 6.3.1	Position controller P-factor [10=1/s]	UINT16 0..32767	14	R/W per.

Setting the reference signal

- ▶ Select the position controller in the field "Recording type" on the tab "Recording" under "Twin Line - Controller - Optimising".
- ▶ Set the reference values on the tab 'Reference variable':
 - Signal form: 'Jump'
 - Amplitude for about 1/10 of a motor revolution
 - with the HIFA-C Hiperface module: 1600 Inc
 - when using the resolver module RESO-C: 400 Inc
 - when using the RS422-C module with incremental encoder with the resolution e.g. 4000 Inc/rev (special case): 400 Inc

Selecting recording signals

- ▶ Select the following signals for recording in the 'Recording' tab under 'Recording objects' and 'Processing':
 - Setpoint of the position controller 'p_ref'
 - Actual position of the position controller 'p_act'
 - - Actual speed of the motor 'n_act'
 - Setpoint current of the current controller 'I_ref'

Controller values for the position controller can be changed in the same parameter group used for the speed controller.

TLHMI: Setting the reference signal

- ▶ Set the reference signal under '6.1 Settings':
 - Signal form: 'Jump' under '6.1.1 Ref_Typ' = 1
 - Amplitude for about 1/10 of a motor revolution under '6.1.3 Amplitude':
 - with the HIFA-C Hiperface module: 1600 Inc
 - when using the resolver module RESO-C: 400 Inc
 - when using the RS422-C module with incremental encoder with the resolution e.g. 4000 Inc/rev (special case): 400 Inc

Controller values for the position controller can be changed under '6.3 Position controller'.

You can not record with the TLHMI.

Optimising the position control value



WARNING!

Unexpected motion may cause injury and damage to the system

The jump function moves the motor in speed mode at constant speed until the specified time has expired.

- Check that the selected values for speed and time do not exceed the available distance.
 - If possible, use limit switches or stop as well.
 - Make sure that a functioning button for EMERGENCY STOP is within reach.
 - Make sure that the system is free and ready for motion before starting the function.
- ▶ Start a jump function with the default controller values.
- ▶ After the first test check the setting of the values 'n_act' and 'I_ref' for current and speed control. The values must not cross into the range of current and speed limiting.

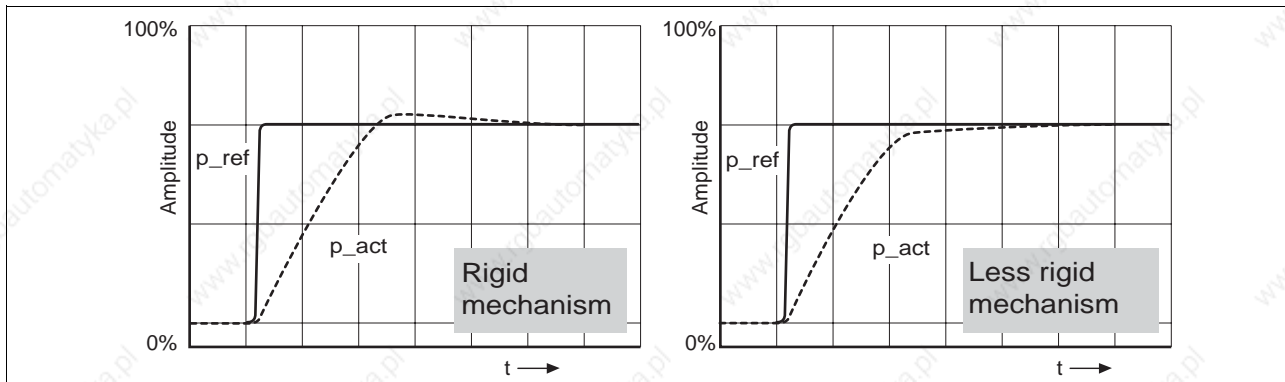

Figure 5.25 Jump responses of a position controller with a good control response

The proportional factor 'K_{Pp}' is at its optimum setting when the motor reaches its target position rapidly and with little or no overshooting.

If the control response does not correspond to the curve shown, change the P-factor 'K_{Pp}' in steps of about 10% and then initiate a jump function once again:

- If the controller tends to oscillate: decrease 'K_{Pp}'.
- If the actual value is too slow following the setpoint value: increase 'K_{Pp}'.

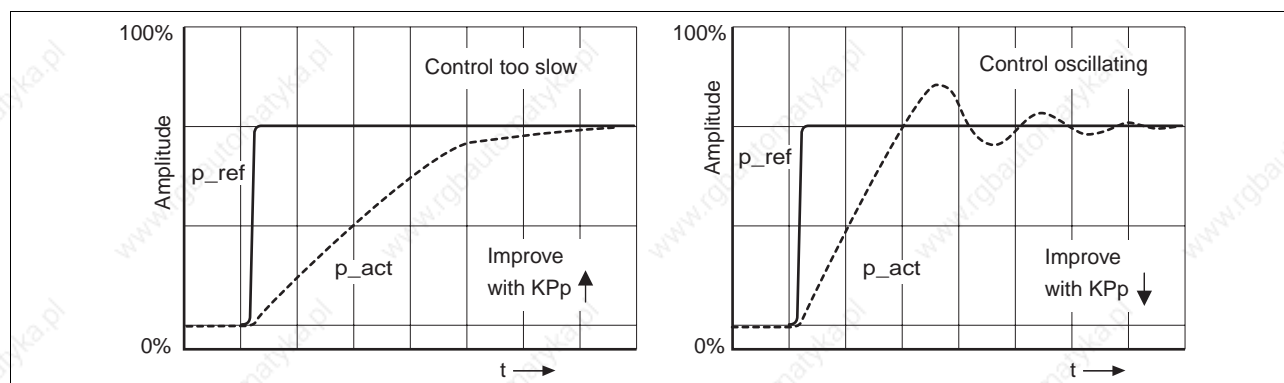

Figure 5.26 Optimising improper settings of the position controller

6 Operating modes of the controller



WARNING!

Danger of injury and damage to system components by loss of control!

- The system manufacturer must consider the possible errors that could occur with the signals and in particular the critical functions to ensure a safe status during and after errors. Critical functions include emergency stop and limiting end positions. Observe the accident prevention regulations.
- Consideration of possible errors must include unexpected delay and failure of signals or functions.
- Separate redundant controller paths must be provided for critical functions.

6.1 Operating modes

Overview

The controller operates in one manual and several automatic operating modes depending on the modules installed. The operating mode of the controller can be changed during movement.

Manual operating mode

- manual movement

Automatic operating modes:

- speed mode
- point-to-point mode
- electronic gear
- referencing
- current control
- oscillator mode

The controller setup mode is implemented during commissioning. It is started automatically with the TLHMI hand-held operating unit or the TLCT commissioning software and runs in the background.

6.1.1 Access channels

Local and remote access Data exchange and control of Twin Line units is possible over various access channels:

- locally through the RS232 interface with the TLHMI hand-held operating unit or the TLCT commissioning software or via the signal interface
- remotely with field bus commands

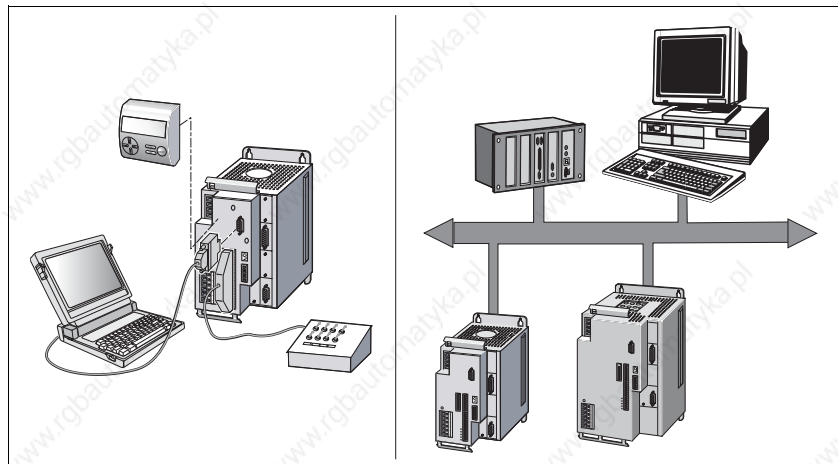

Figure 6.1 Local and remote access to Twin Line units

Automatic access security If an operating mode is initiated through an access channel, the operating mode can only be changed with this access channel during processing. A different operating mode can be selected with other access channels only after the current operation is finished.

When the operating mode is changed, the motor stops briefly and activates the drive parameters and specific settings for the new operating mode.

Access by other access channels to the Twin Line unit can be enabled and disabled with the parameter `Commands.OnlAuto`.

Group.Name	Idx:Six dec (hex)	TLHMI	Explanation and unit []	Value range	Default value	R/W per.
<code>Commands.OnlAuto</code>	29:30 (1D:1E _h)	-	Access to the mode setting	UINT16 0..65535 0: access via all access channels 1: access only via the channel that set this parameter	0	R/W-

Access via other access channels is not available unless the access channel that set the parameter resets it to '0' or if the access port is interrupted (for example, with Fieldbus mode).

6.1.2 Access control for selecting operating mode or function

Enabling the access channels and the selection options of the operating modes are specified by the parameter `Settings.IO_mode`.

Group.Name	Idx:Six dec (hex)	TLHMI	Explanation and unit []	Value range	Default value	R/W per.
Settings.IO_mode	29:31 (1D:1F _h)	4.1.4	Significance of I/O signal assignment	UINT16 0..2 0: settings of field bus parameter via I/O assignment 1: I/O freely available 2: I/O assigned with function	0	R/W per.

IO_mode=0 or 1 Inputs and outputs of the signal interface can be assigned at `Settings.IO_mode = 0` for the field bus configuration or are freely available at `Settings.IO_mode = 1`. In both cases operating modes can be started with equal authorisation with the TLHMI hand-held operating unit, TLCT commissioning software, user program or over the Fieldbus.

Operating modes and functions ¹⁾	TLHMI	TLCT	I/O of signal interface	Field bus
manual mode	•	•	–	•
point-to-point mode	•	•	–	•
speed mode	•	•	–	•
Electronic gear	•	•	–	•
Referencing	•	•	–	•
Controller optimisation	•	•	–	–
Current control	–	•	–	–
Oscillator mode	–	•	–	–

1) •: access possible, –: no access

IO_mode=2 If the parameter `Settings.IO_mode = 2`, inputs and outputs of the signal interface are permanently assigned. Operating modes and functions can be started locally or via the Fieldbus depending on the AUTOM input signal.

ATTENTION:

At units with CANopen, operating modes and functions can be started via CANopen independent of the AUTOM input signal.

- AUTOM=0, low level: locally via HMI hand-held operating unit, TLCT commissioning software or signal interface
- AUTOM=1, high level: via field bus

The following table shows the operating modes and functions available depending on the status of the AUTOM signal.

Operating modes and functions ¹⁾	TLHMI	TLCT	I/O of signal interface	Field bus
manual mode	0	0	0	1
point-to-point mode	0	0	–	1
speed mode	0	0	–	1
Electronic gear	0	0	–	1
Referencing	0	0	–	1
Controller optimisation	0	0	–	–

Operating modes and functions ¹⁾	TLHMI	TLCT	I/O of signal interface	Field bus
Current control	–	0	–	1
Oscillator mode	–	0	–	1

1) 0: AUTOM=0, 1: AUTOM=1

6.1.3 Selecting the operating mode



WARNING!

Danger of personal injury and damage to system parts by uncontrolled system operation!

- Note that inputs to these parameters are executed by the drive controller immediately on receipt of the data set.
- Make sure that the system is free and ready for movement before changing these parameters

Operating modes in the Twin Line unit are set by action commands. The TLHMI hand-held operating unit and TLCT commissioning software offer these action command as menu items and dialog boxes. In field bus operation, the action commands are given by parameters.

Operation can be switched between manual mode and automatic mode, which can be set via parameters, via the signal interface. This requires fixed assignment of the signal interface.

The currently set operating mode can be monitored with the bits in the parameter `Status.xMode_act`.

Example of PTP mode

The parameter for initiating the PTP operating mode with absolute positioning is:

Group.Name	Idx:Six dec (hex)	TLHMI	Explanation and unit []	Value range	Default value	R/W per.
PTP.p_absPTP	35:1 (23:1 _h)	3.1.1.1	Start of absolute positioning with transfer of absolute target position value [usr]	INT32 -2147483648..2147483647	–	R/W-

When using the TLHMI hand-held operating unit the PTP operating mode is started via menu item "3.1.1.1".

In Fieldbus mode, index and subindex are used for starting the operating mode. The command for PTP positioning with the position value 324 mm:

Sending/receiving data	Comments	
Command 04 01 00 23. 00 00 01 44h	04: 01 00 23h: 01 44h:	sf=0, write access subindex 1: index 35 324 mm
Acknowledgement 00 23 00 06 . 00 00 00 00h	23h: 00 06h:	ref_ok=1, PTP mode motion_end=0, power amplifier on

Status information is sent back as acknowledgement, thereby enabling the change of operating mode to be monitored.

The TLCT commissioning software can be used to open the "Positioning" dialog box from "Twin Line - Positioning". In the "PTP" tab settings can be made and the operating mode started.

6.1.4 Monitoring the set operating mode

The specified operating mode can be monitored with status parameters or via outputs from the signal interface.

Status Parameter

The controller has a global and an operating-mode-specific status parameter for monitoring its operation.

The status parameter `Status.driveStat` provides global information on the operating status of the unit and the processing status.

Group.Name	Idx:Six dec (hex)	TLHMI	Explanation and unit []	Value range	Default value	R/W per.
Status.driveStat	28:2 (1C:2 _h)	2.3.5.1	Status word for the operating status	UINT32 0..429496795 Bit0..3: Current operating status: - 1: Start - 2: Not Ready to switch on - 3: Switch on disabled - 4: Ready to switch on - 5: Switched on - 6: Operation enable - 7: Quick-Stop active - 8: Fault response enabled - 9: Fault Bit4: reserved Bit5=1: error internal monitoring (FltSig) Bit6=1: error external monitoring (FltSig_SR) Bit7=1: warning message Bit8..11: not assigned Bit12..15: operating-mode-specific coding of the processing status Bit13: x_add_info Bit14: x_end Bit15: x_err Bit16-20: current operating mode (corresponds to Bit0-4: Status.xmode_act) 0: not used 1: manual positioning mode 2: referencing 3: PTP positioning 4: speed profile 5: electronic gear with offset adjustment, position-controlled (AC) or with position reference (SM) 6: electronic gear speed-controlled 7: data set mode 8: function generator (current controller) 9: function generator (speed controller) 10: function generator (position controller) 11..15: cannot be set 16: function generator in status disabled 17: current regulation 18: oscillator mode 19: cam profile CAM 20..30: reserved 31: do not use Bit21: drive is referenced (ref_ok) Bit22: control deviation in position window (SM not assigned)	-	R/- -

Global status bits The status bits (bit 13 - bit 15) in the status parameter are taken unchanged from the status bits of operating mode specific status parameters: The global status bits have the same significance as the status bits of the individual mode:

Status bit	Function	Value
Bit 13: x_add_info	Additional information depending on operating mode	0/1
Bit 14: x_end	Machining running machining complete, motor stationary	0 1
Bit 15: x_err	Error-free operation error occurred	0 1

Mode-specific status parameters Every operating mode has its own status parameter, which contains information on the processing status in bits 13 to 15.

For example, for this operating mode it is:

Group.Name	Idx:Six dec (hex)	TLHMI	Explanation and unit []	Value range	Default value	R/W per.
PTP.statePTP	35:2 (23:2 _h)	3.2.14	Acknowledgement: PTP positioning	UINT16 0..65535 Bit0: error LIMP Bit1: error LIMN Bit2: error HW_STOP Bit3: error REF Bit5: error SW_LIMP Bit6: error SW_LIMN Bit7: error SW_STOP Bit13: setpoint position reached Bit14: motion_end Bit15: motion_err	–	R/- -

Status via I/O signals The operating states via the signal interface can be evaluated if the interface assignment is fixed.

I/O signal	Function	Value
AXIS_ADD_INFO	Additional information depending on operating mode	Low/High
AXIS_END	Machining running machining complete, motor stationary	Low High
AXIS_ERR	Error-free operation error occurred	Low High

As soon as an operating mode has been set and the process initiated, bit 14 changes to '0'. When the process is finished, bit 14 changes back to '1' thereby indicating that further process steps can now be executed.

Bit 14's signal change to '1' is suppressed if one process is followed immediately by a new process in a different operating mode.

If bit 15 shows the value "1", there is an error that must be corrected before machining. The controller responds depending on an error class, see Chapter 8 „Diagnostics and troubleshooting“, page 8-1.

6.1.5 Status monitoring in movement mode

Status parameters In movement mode the controller can be monitored with the parameters of the parameter group "Status". The parameters are read only.

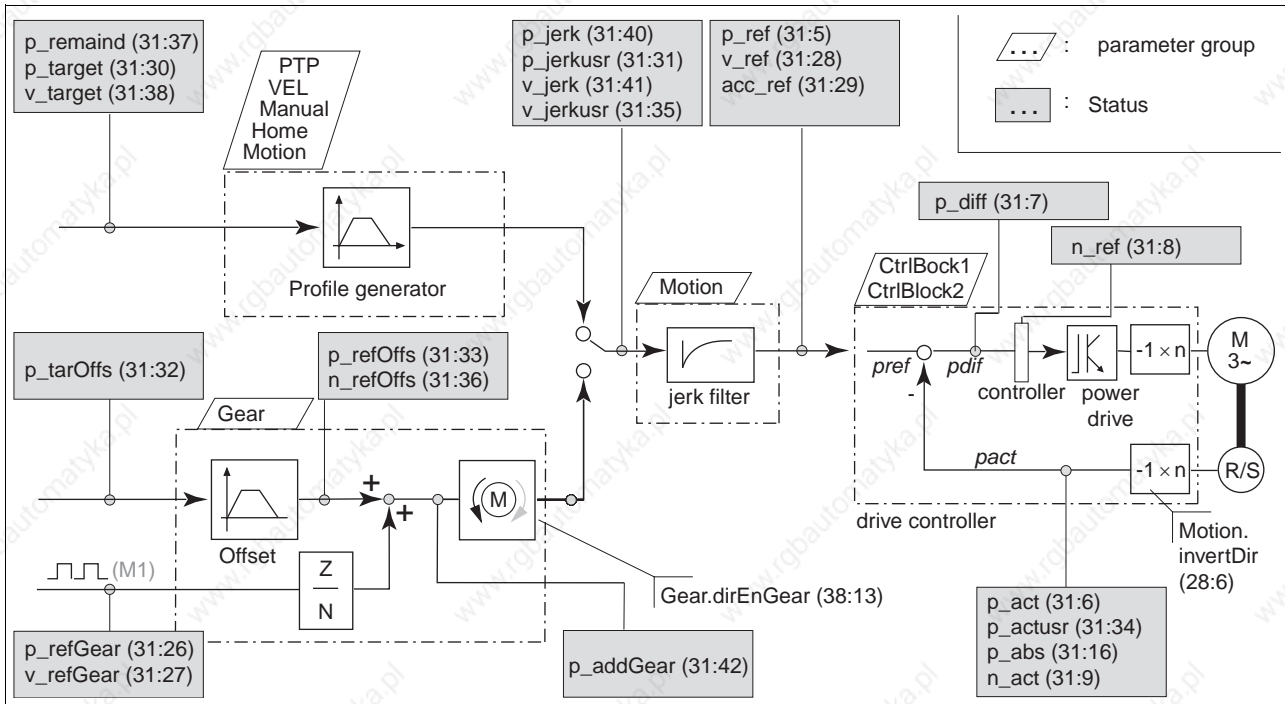

Figure 6.2 Monitoring movement mode with status parameters; actual position determined by M2



For the sake of simplicity the operating modes "current regulation" and "oscillator mode" are not shown in the diagram. For more information see page 6-45 and 6-50.

Parameter sets

Operating modes are set via parameters in parameter groups specific to that mode:

- PTP group: Settings for Point-to-Point mode
- VEL group: Settings for speed mode
- Gear group: Settings for electronic gear mode with superimposed offset
- Motion group: Parameter settings for all modes: jerk filter, direction of rotation, software limit switches, standardisation and ramp settings.

Setting options for manual mode are in the 'Manual' parameter group, for referencing in the 'Home' group. You will find a list of all parameter groups in the chapter entitled 9 „Parameters“, page 9-1

Profile generator Target position and final speed are input values to be entered by the user. The profile generator uses these values to calculate a motion profile dependent on the selected operating mode. The output values from the profile generator and an upstream jerk filter are converted into motor movements by the drive controller. You will find information on the jerk filter in chapter 7.4 „Ramp function“ from page 7-18

In the electronic gear operating mode, positioning values are calculated from the input pulses fed in via a module in the M1 slot. An additional positioning offset can be superimposed by entering an offset position. The offset position is processed via the profile generator.

6.2 Manual movement



Danger of personal injury and damage to system parts by uncontrolled system operation!

- Note that inputs to these parameters are executed by the drive controller immediately on receipt of the data set.
- Make sure that the system is free and ready for movement before changing these parameters

Overview of manual movement

Manual movement is carried out as 'classic manual movement' or as 'united inching'. In both operating modes the motor is moved over a prescribed distance by start signals.

The operating mode can be executed by

- TLHMI hand-held operating unit
- TLCT Commissioning Software
- Fieldbus
- Signal interface inputs when the signal interface is permanently assigned.

Operation with TLCT or TLHMI

The commissioning software and the HMI hand-held operating unit support this operating function with special dialog boxes and menu items. For details see the manuals for the commissioning software and the TLHMI hand-held operating unit.

Starting manual mode

The starting conditions for a manual movement depend on the settings of the signal interface assignments. The setting is switched with the parameter `Settings.IO_mode`.

- Free assignment, parameter value `Settings.IO_mode = 0` or `1`:
The positioning controller switches to manual movement as soon as the movement is started by an operating unit or with the parameter `Manual.startMan` over the field bus. A manual movement via the signal interface is not possible with free assignment of the interface.
- Fixed assignment, parameter value `Settings.IO_mode = 2`:
Where the input signal `AUTOM = 0` manual operation can be started via the interface inputs or an operating unit as soon as the output `AUTOM_ACK` switches to low level. If the input signal `AUTOM = 1`, the manual movement can be started with the parameter `Manual.startMan` over the field bus as soon as `AUTOM_ACK` executes high level.

Only with fixed assignment can the motor be moved at two speeds in both directions via the input signals `MAN_P`, `MAN_N` and `MAN_FAST`.

The manual movement is started with the parameter `Manual.startMan`. The current axis position is the start position for manual movement. The values for position and speed for which parameters can be set are entered in user-defined units.

Manual movement is finished when the motor has stopped and

- in the case of classical manual movement, the direction signal is inactive

- in the case of united inching, the inching distance has been covered
- the operating mode has been interrupted by a fault response

The parameter `Manual.statusMan` provides information on the processing status.

Group.Name	Idx:Six dec (hex)	TLHMI	Explanation and unit []	Value range	Default value	R/W per.
Manual.startMan	41:1 (29:1 _h)	3.2.1	Start of manual movement with transfer of control bits	UINT16 0..7 Bit2: 0: slow 1: fast Bit1: neg. direction of rotation Bit0: pos. sense of rotation	–	R/W-
Manual.statusMan	41:2 (29:2 _h)	–	Acknowledgement: Manual movement	UINT16 0..65535 Bit0: error LIMP Bit1: error LIMN Bit2: error HW_STOP Bit3: error REF Bit 5: error SW_LIMP Bit 6: error SW_LIMN Bit 7: error SW_STOP Bit14: manu_end Bit15: manu_err	–	R/- -

Manual movement enabled and started via the interface signals:

I/O signal	Function	Value
E: AUTOM	Switching to manual operating mode Switching to automatic operating mode	0 / open 1
A: AUTOM_ACK	Manual operating mode possible Manual operating mode not possible	0 / open 1
E: MAN_N	Traverse in anticlockwise direction of rotation	1
E: MAN_P	Traverse in clockwise direction of rotation	1
E: MAN_FAST	Slow speed Fast speed	0 / open 1

Selecting manual movement mode

Manual movement can be carried out in two processing modes:

- Classical manual movement
- United inching

The processing modes are selected with the parameter `Manual.typeMan`.

Group.Name	Idx:Six dec (hex)	TLHMI	Explanation and unit []	Value range	Default value	R/W per.
Manual.typeMan	41:3 (29:3 _h)	3.2.2	Type of manual movement	UINT16 0..1 0: classical inching 1: united inching	0	R/W per.

Classical manual movement At the start signal for manual movement the motor first moves over a defined path `Manual.step_Man`. If the start signal is still present after a specific delay period `Manual.time_Man`, the controller switches to continuous movement mode until the start signal is cancelled.

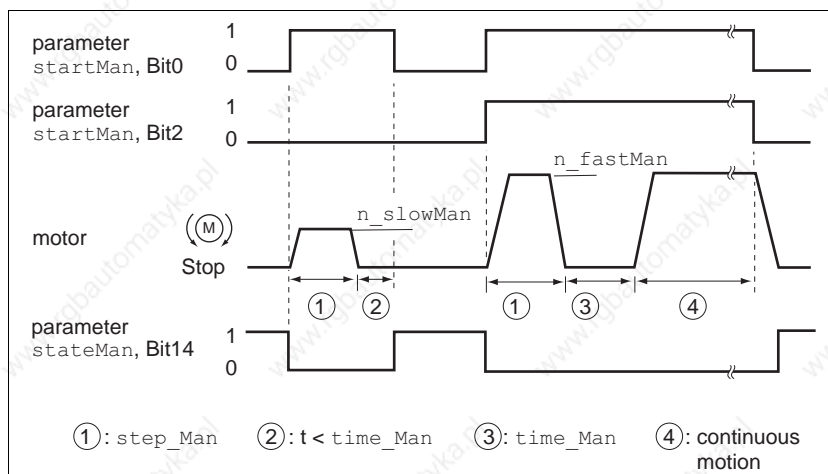

Figure 6.3 Classical manual movement, slow and fast

The inching distance, delay and manual movement speeds can be set. If the inching distance is zero, manual movement starts directly with continuous movement irrespective of the delay.

Group.Name	Idx:Six dec (hex)	TLHMI	Explanation and unit []	Value range	Default value	R/W per.
Manual.n_slowMan	41:4 (29:4 _h)	3.2.3	Speed for slow manual movement [usr]	UINT32 1..2147483647	60	R/W per.
Manual.n_fastMan	41:5 (29:5 _h)	3.2.4	Speed for fast manual movement [usr]	UINT32 1..2147483647	180	R/W per.
Manual.step_Man	41:7 (29:7 _h)	3.2.6	Inch travel, defined travel on manual movement start [usr] 0: Continuous operation	UINT16 0..65535	20	R/W per.
Manual.time_Man	41:8 (29:8 _h)	3.2.7	Classical waiting time [ms]	UINT16 1..30000	500	R/W per.

United inching The motor moves a defined distance at every start signal for manual movement. If the start signal is cancelled before the destination is reached, the controller stops the motor immediately.

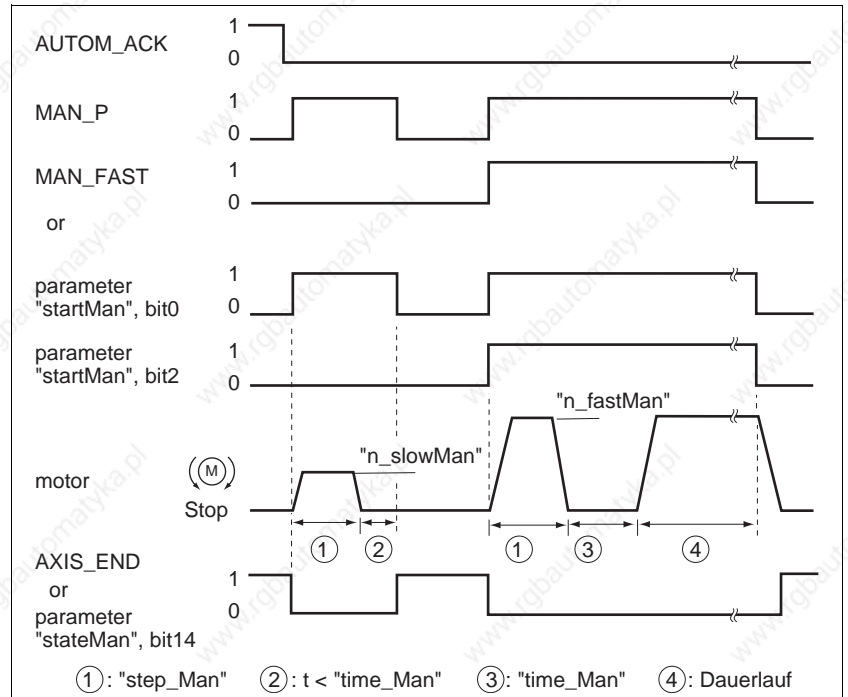

Figure 6.4 Manual movement with united inching

The distance to be covered and manual movement speeds can be set.

Group.Name	Idx:Six dec (hex)	TLHMI	Explanation and unit []	Value range	Default value	R/W per.
Manual.n_slowMan	41:4 (29:4 _h)	3.2.3	Speed for slow manual movement [usr]	UINT32 1..2147483647	60	R/W per.
Manual.n_fastMan	41:5 (29:5 _h)	3.2.4	Speed for fast manual movement [usr]	UINT32 1..2147483647	180	R/W per.
Manual.dist_Man	41:6 (29:6 _h)	3.2.5	Inch travel, defined travel per jog cycle with united inching [usr]	UINT16 1..65535	20	R/W per.

Setting options You will find further possible settings and functions for manual operation in:

- Changing acceleration and delay behaviour using 'ramp function', 'jerk filter' and 'quick stop function'
- Making position-dependent speed or signal changes with 'list control and list data processing'
- Adapting user-defined units and internal units with the 'calibration' function.
- Setting unit and movement monitoring with 'monitoring functions' and 'standstill window'
- Set current limiting for manual mode via parameter `Manual.I_MaxMan`.

Example A simple, partially automated movement mode can be set up by controlling the signals for manual movement with a manually operated switch and cam switches.

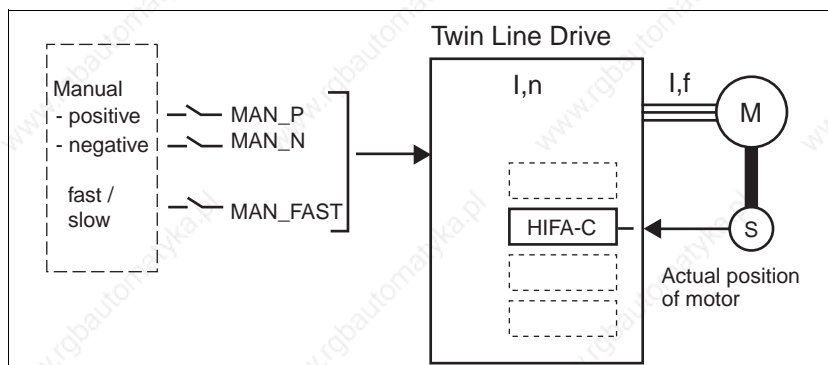

Figure 6.5 manual mode

6.3 Speed mode



WARNING!

Danger of personal injury and damage to system parts by uncontrolled system operation!

- Note that inputs to these parameters are executed by the drive controller immediately on receipt of the data set.
- Make sure that the system is free and ready for movement before changing these parameters

Overview of speed mode

In speed mode, a setpoint speed is specified for the motor over the profile generator, and movement is initiated with no defined target point. The motor moves at this speed until a different speed is set or the operating mode is terminated.

The operating mode can be executed by

- TLHMI hand-held operating unit
- TLCT commissioning software
- Fieldbus

Operation with TLCT or TLHMI

The commissioning software and the HMI hand-held operating unit support this operating function with special dialog boxes and menu items. For details see the manuals for the commissioning software and the TLHMI hand-held operating unit.

Starting speed mode

As soon as a speed value is transferred to the controller with the parameter `VEL.velocity`, the unit switches to speed mode and accelerates to the setpoint speed.

Processing in speed mode is completed when the set speed and actual speed are zero or when the operating mode is interrupted by a fault response. The parameter `VEL.stateVEL` provides information on the processing status.

Group.Name	Idx:Six dec (hex)	TLHMI	Explanation and unit []	Value range	Default value	R/W per.
VEL.velocity	36:1 (24:1 _h)	3.1.2.1	Start of speed change with transfer of setpoint speed [usr]	INT32 -2147483648 ..2147483647	–	R/W-
VEL.stateVEL	36:2 (24:2 _h)	–	Acknowledgement: Speed profile mode	UINT16 0..65535 Bit0: error LIMP Bit1: error LIMN Bit2: error HW_STOP Bit3: error REF Bit5: error SW_LIMP Bit6: error SW_LIMN Bit7: error SW_STOP Bit13: Setpoint speed reached Bit14: vel_end Bit15: vel_err	–	R/- -

Settings The set speed is transmitted in user-defined units and can be changed while the motor is in motion. Speed mode is not limited by the positioning range limits.

New ramp settings are imported when a speed value is transferred with `VEL.velocity`.

You will find further possible settings and functions for speed mode in:

- Changing acceleration and delay behaviour using 'ramp function', 'jerk filter' and 'quick stop function'
- Making position-dependent speed or signal changes with 'list control and list data processing'
- Creating list data with the "Teach-In process"
- Adapting user-defined units and internal units with the 'calibration' function.
- Setting unit and movement monitoring with 'monitoring functions' and 'standstill window'

6.4 Point-to-point mode



WARNING!

Danger of personal injury and damage to system parts by uncontrolled system operation!

- Note that inputs to these parameters are executed by the drive controller immediately on receipt of the data set.
- Make sure that the system is free and ready for movement before changing these parameters

Overview of point-to-point mode

In point-to-point mode (also PTP mode) the motor is positioned from point A to point B with a positioning command. The positioning distance is given either in absolute terms with reference to the reference point of the axis or in relative terms to the current position of the axis.

Before an absolute positioning the reference point must be defined by referencing.

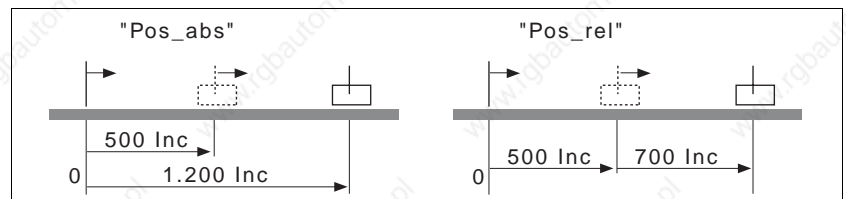

Figure 6.6 Point-to-point positioning, absolute and relative

The operating mode can be executed by

- TLHMI hand-held operating unit
- TLCT commissioning software
- Fieldbus

Operation with TLCT or TLHMI

The commissioning software and the HMI hand-held operating unit support this operating function with special dialog boxes and menu items. For details see the manuals for the commissioning software and the TLHMI hand-held operating unit.

Starting PTP mode

As soon as the positioning value is transferred in the parameter `PTP.p_abs` or `PTP.p_rel`, the controller switches to PTP mode and starts the positioning at the setpoint speed, which is stored in the parameter `PTP.v_tar`.

The positioning process is finished when the target position has been reached and the motor has stopped, or when the operating mode is interrupted by a fault response. The parameter `PTP.State` provides information on the processing status.

If a mode other than PTP mode is active, relative positioning may only be initiated when the motor is at standstill.

Group.Name	Idx:Six dec (hex)	TLHMI	Explanation and unit []	Value range	Default value	R/W per.
PTP.p_absPTP	35:1 (23:1 _h)	3.1.1.1	Start of absolute positioning with transfer of absolute target position value [usr]	INT32 -2147483648..2147483647	-	R/W-
PTP.statePTP	35:2 (23:2 _h)	3.2.14	Acknowledgement: PTP positioning	UINT16 0..65535 Bit0: error LIMP Bit1: error LIMN Bit2: error HW_STOP Bit3: error REF Bit5: error SW_LIMP Bit6: error SW_LIMN Bit7: error SW_STOP Bit13: setpoint position reached Bit14: motion_end Bit15: motion_err	-	R/-
PTP.p_relPTP	35:3 (23:3 _h)	3.1.1.2	Start of relative positioning with transfer of the value for the distance [usr]	INT32 -2147483648..2147483647	0	R/W-
PTP.continue	35:4 (23:4 _h)	3.1.1.3	Continuation of interrupted positioning with transfer of any value	UINT16 0..65535 value is not relevant for positioning	-	R/W-
PTP.v_tarPTP	35:5 (23:5 _h)	3.1.1.5	Setpoint speed of PTP positioning [usr]	INT32 1..2147483647	Motion.v_target0	R/W-

Continuing PTP mode

If a positioning is interrupted, e.g. by an external stop signal, the process can be continued by a write access to the parameter `PTP.continue` and completed. The cause of interruption must first be disabled.

The value transferred with `PTP.continue` is not evaluated.

Settings for PTP operation

Position and speed values are given in user units. If one of the values changes, the controller follows immediately.

New ramp settings are accepted when the motor starts with a new predefined position.

You will find further settings and functions for PTP operation in:

- Changing acceleration and delay behaviour using 'ramp function', 'jerk filter' and 'quick stop function'
- Making position-dependent speed or signal changes with 'list control and list data processing'
- Creating list data with the "Teach-In process"
- Adapting user-defined units and internal units with the 'calibration' function.
- Setting unit and movement monitoring with "monitoring functions" and "standstill window".

6.5 Electronic gear



WARNING!

Danger of personal injury and damage to system parts by uncontrolled system operation!

- Note that inputs to these parameters are executed by the drive controller immediately on receipt of the data set.
- Make sure that the system is free and ready for movement before changing these parameters

Overview of electronic gear

In the electronic gear mode, the controller calculates a new position setpoint for the motor movement from a predefined position and an adjustable gear factor. This mode is used when one or more motors are to follow the reference signal from a NC control unit or an encoder.

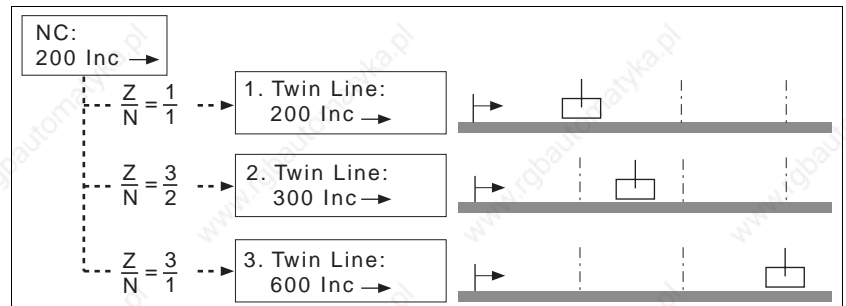

Figure 6.7 Electronic gear with three Twin Line units, gear ratio adjustable via gear factor (Z, N)

A PTP offset movement can be superimposed on the positioning process, and this can be used to alter the position setpoint.

The RS422-C encoder module the PULSE-C pulse/direction module must be installed in slot M1 for the electronic gear mode. Different types of signal can be fed depending on the module:

- A/B signals with four-way evaluation of sensor signals with the RS422-C module
- Pulse/direction or pulse_{forward}/pulse_{back} signals with the PULSE-C module.



Electronic gear mode can only be used when there is no position control with an additional incremental encoder.

The operating mode can be executed by

- TLHMI hand-held operating unit
- TLCT commissioning software
- Fieldbus

Operation with TLCT or TLHMI

The commissioning software and the HMI hand-held operating unit support this operating function with special dialog boxes and menu items. For details see the manuals for the commissioning software and the TLHMI hand-held operating unit.

Starting electronic gear The operating mode is enabled with the parameter `Gear.startGear`. If reference pulses are fed in, the controller offsets them against the gear factor and positions the motor at the new setpoint.

Position values are given in internal increments. If the values change, the controller follows immediately. Electronic gear mode is not limited by the positioning area boundaries.

The process is finished when gear processing has been deactivated and the motor stationary, or if the mode was interrupted. If the controller switches from the operating status "6 Operation enable" to a different status, gear processing is automatically deactivated, e.g. if the motor is stopped by Quick-Stop. The parameter `Gear.stateGear` provides information on the processing status.

Synchronisation In the electronic gear mode the controller operates synchronously in the gear compound, e.g. with other drives. If the controller stops gear processing briefly, the synchronism to the other drives is lost. When gear processing is restarted, the drive has two ways of re-establishing synchronisation.

- Immediate synchronisation: The controller follows reference pulses from the time at which the gear processing is activated. Reference pulses, offset entries and position changes that have occurred before the mode started are not taken into consideration.
- Synchronisation with compensatory motion: When gear processing is activated, the drive makes a compensatory movement in an attempt to reach the position which it would have gone to if no interruption had taken place.

There are various conditions attached to synchronisation with compensatory movement. For more information on this subject see 6.5.2 „Synchronisation with compensatory movement“, page 6-24

The type of synchronisation is set with the parameter `Gear.startGear`, which starts the operating mode simultaneously.

Group.Name	Idx:Six dec (hex)	TLHMI	Explanation and unit []	Value range	Default value	R/W per.
Gear.startGear	38:1 (26:1 _h)	3.1.3.1	Starting an electronic gear process with selection of the processing mode	UINT16 0..2 0: disabled 1: immediate synchronisation 2: Synchronisation with compensatory movement	-	R/W-
Gear.stateGear	38:2 (26:2 _h)	-	Acknowledgement: gear processing	UINT16 0..65535 Bit0: error LIMP Bit1: error LIMN Bit2: error HW_STOP Bit3: error REF Bit5: error SW_LIMP Bit6: error SW_LIMN Bit7: error SW_STOP Bit13: - Bit14: gear_end Bit15: gear_err	-	R/-

6.5.1 Gear settings

Overview Setting values for electronic gear, regardless of the type of synchronisation, are

- Gear factor
- current limitation
- Speed limitation
- size of following error
- offset value for PTP offset positioning
- enabling sense of rotation

You will find further settings and functions for electronic gear mode in:

- Changing acceleration and delay behaviour using 'current limiting', 'jerk filter' and 'quick stop function'
- Making position-dependent signal changes with 'list control and list data processing'
- Creating list data with the "Teach-In process"
- Setting unit and movement monitoring with "monitoring functions" and "standstill window".

Gear factor The gear factor is the ratio between motor increments and externally fed reference increments for motor movement. The gear factor is defined with the parameters for numerators and denominators. A negative numerator value reverses the motor's direction of rotation. The gear ratio is preset to 1:1.

$$\text{Gear factor} = \frac{\text{Motor increments}}{\text{Reference increments}} = \frac{\text{Gear factor numerator}}{\text{Gear factor denominator}}$$

At a setting of 1000 reference increments the motor should rotate 2000 motor increments. This yields a gear factor of 2.



A new gear ratio is activated when the numerator value is supplied.

Group.Name	Idx:Six dec (hex)	TLHMI	Explanation and unit []	Value range	Default value	R/W per.
Gear.numGear	38:7 (26:7 _h)	3.1.3.2	Gear factor numerator	INT32 -2147483648..2147483647	1	R/W-
Gear.denGear	38:8 (26:8 _h)	–	Gear factor denominator	INT32 1..2147483647	1	R/W-

The resulting positioning path is dependent on the current motor resolution, e.g.

- 16384 pulses/rev. for Hiperface motors
- 4096 pulses/rev. for resolver motors.

current limitation

The maximum values for acceleration and deceleration are derived from the current limitation. They are not limited by ramp functions as in PTP

mode, for example. To protect the drive system the current limiting must be set in accordance with the installed drive system with the following parameters:

Parameter	Working phase	Info
CtrlBlock1/2.I_max	Acceleration/deceleration in electronic gear mode	Chapter 5.4.5 „Setting device parameters“, page 5-13
	Deceleration during Quick-Stop, if Settings.SignQstop = 0	Chapter 7.5 „Quick-Stop function“, page 7-20
Settings.lmaxSTOP	Deceleration during Quick-Stop, if Settings.SignQstop = 1	Chapter 7.5 „Quick-Stop function“, page 7-20
	Deceleration with error with error class 1 or 2	Chapter 8.3 „Error display and troubleshooting“, page 8-4

Speed limitation The maximum speed is specified by the controller setting of the parameters CtrlBlock1.n_max or CtrlBlock2.n_max. For more information see chapter 5.4.5 „Setting device parameters“ from page 5-13

Following error If the pulse frequency at the setpoint input changes quickly, the drive will not be able to follow a positioning setpoint directly. A temporary following error results. To prevent this following error causing the power amplifier to be switched off, a following error threshold value can be set, see „Following error monitoring“ from page 7-34

Direction enabling Direction enabling prevents any movement opposed to the desired direction of travel, which could occur with compensatory or offset movements. Direction enabling is set with the parameter Gear.dirEnGear.

Group.Name	Idx:Six dec (hex)	TLHMI	Explanation and unit []	Value range	Default value	R/W per.
Gear.DirEnGear	38:13 (26:D _h)	–	Enabling the motion direction When the direction is reversed the enabling direction is reversed	INT16 1..3 1: positive direction 2: negative direction 3: both directions	3	R/W per.

Gear processing example An NC controller sends a position setpoint to two units. The motors execute different, proportional positioning movements in accordance with the gear ratios.

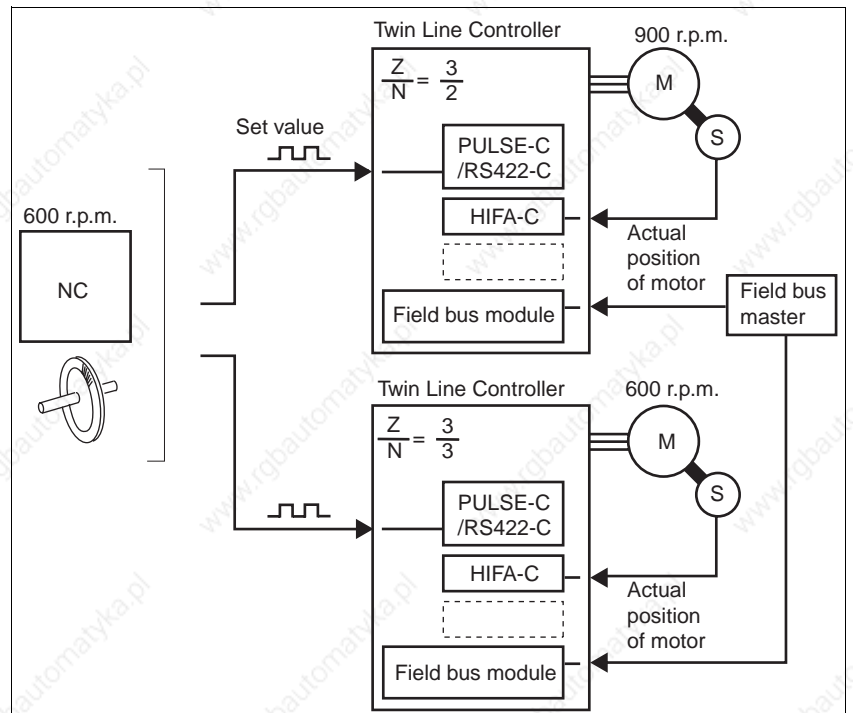

Figure 6.8 Electronic gear with setpoint preset via NC controller or encoder

6.5.2 Synchronisation with compensatory movement

Synchronisation with compensating movement can be used to uncouple and recouple the positioning controller for a short time in a coupled gear system. This action can take place without losing synchronisation with the other gears. In the compensation motion the controller includes all reference pulses, position changes and offset inputs that occur during the interruption and attempts to approach the precise position that it would have reached without an interruption.

Conditions for a compensatory movement

The controller can be decoupled from the synchronous operation with the following actions:

- Switching off the operating mode with `Gear.startGear = 0`
- Starting a different mode
- Quick-Stop.

The power amplifier must remain switched on. If it is switched off, all stored reference pulses will be lost when it is switched on again.

Starting a compensatory movement

The parameter `Gear.startGear = 2` is used to start electronic gear mode with compensation motion.

The controller attempts to catch up with reference pulses that expired before activation of the operating mode as quickly as possible. It is limited in this process by the maximum current `CtrlBlock1.I_max` or `CtrlBlock2.I_max` and the maximum speed `CtrlBlock1.n_max` or `CtrlBlock2.n_max`. As soon as the gear processing is enabled, the control deviation that occurred by the expired pulses must not be greater than the following error threshold value `Settings.p_maxDiff`. Otherwise the controller will report a following error.

Establishing positional deviation

A position deviation during gear processing can be calculated by comparison of the parameters `Status.p_addGear` and `Status.p_ref`.

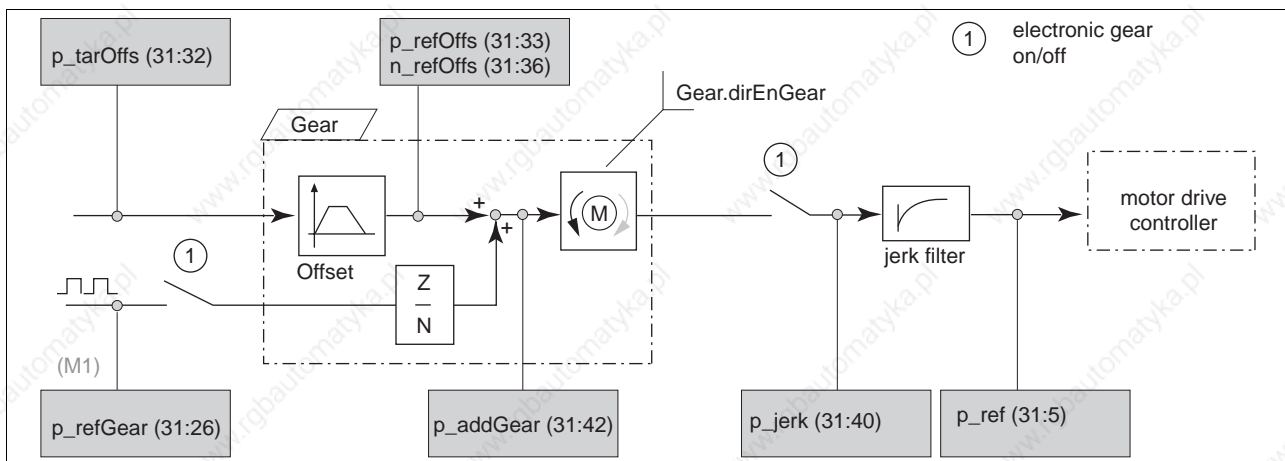

Figure 6.9 Parameters for establishing a positional deviation

When deactivating the electronic gear the parameter `Status.p_addGear` is no longer activated.

Direction preset

Before activating gear processing the direction of a compensation motion can be input with the parameter `Gear.dirEnGear`. For correct re-

lease of a direction the direction inversion function must be considered. It can be calculated with the parameter `Motion.invertDir`.

6.5.3 Offset positioning

A point-to-point offset positioning operation can be superimposed on a positioning operation in electronic gear mode. This is used to alter the position setpoint of the position controller by adding the offset value. For example, it can be used to trigger a position offset in continuous processing.

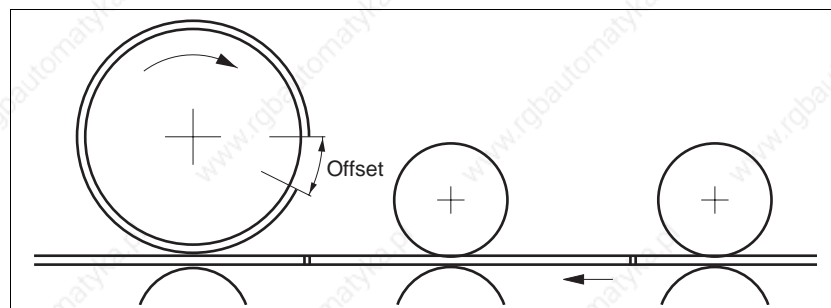

Figure 6.10 Offset for bridging an empty area when printing

The offset traverse is started as soon as the parameter `Gear.p_absOffs` or `Gear.p_relOffs` is transferred. Offset values are given in internal incremental units as relative or absolute values. They therefore depend on the type of encoder used.

The parameter `Gear.StateOffs` provides information on the processing status.

If the mode changes from electronic gear to a different mode, any running offset positioning operation is immediately interrupted and the current positioning operation is finished.

Settings The offset movement is added to the reference pulses of a running gear processing operation. PTP positioning can be set to be executed by ramp or jump. The following information assumes a ramp setting.

Group.Name	Idx:Six dec (hex)	TLHMI	Explanation and unit []	Value range	Default value	R/W per.
Gear.ModeOffs	39:9 (27:9 _r)	3.1.3.12	Processing mode of an absolute or relative positioning	UINT16 0..1 0: jump 1: Profile	0	R/W per.

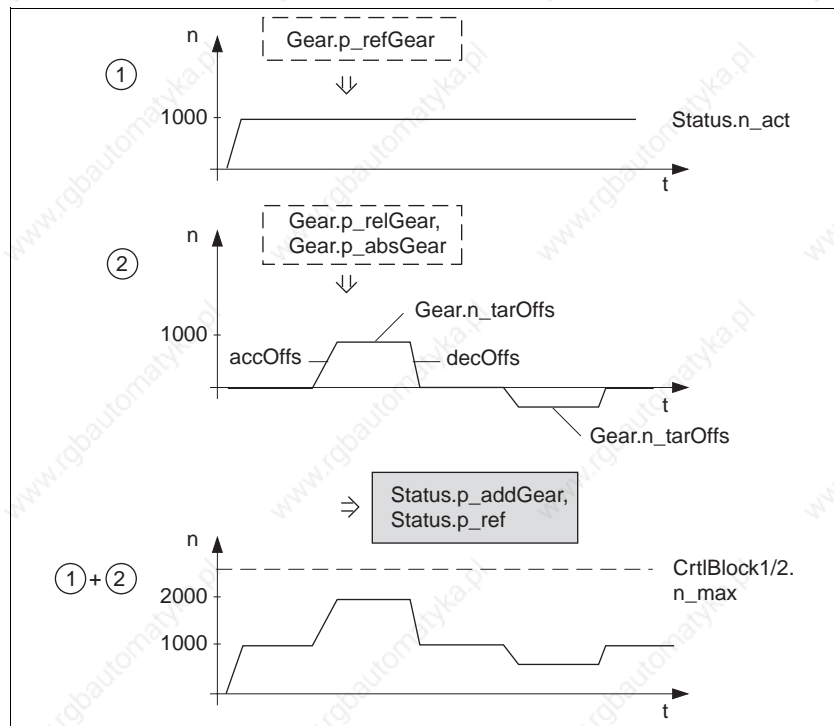

Figure 6.11 Constant movement with superimposed offset positioning

If gear processing has been disabled, the offset value is immediately set off against the reference pulses with no limitation from offset ramp values. For example, a setpoint position can be corrected for synchronisation with compensatory movement.

Dimension setting

The operator is free to switch freely between absolute and relative movement. The positioning range of an absolute value can be set to defined value with the offset parameter `Gear.p_omeOffs`. This does not cause the motor to move.

Monitoring

The predefined position is given as absolute value in increments in the parameter `Status.p_tarOffs`. The current position value and the speed can be calculated with `Status.p_refOffs` and `Status.n_refOffs`.

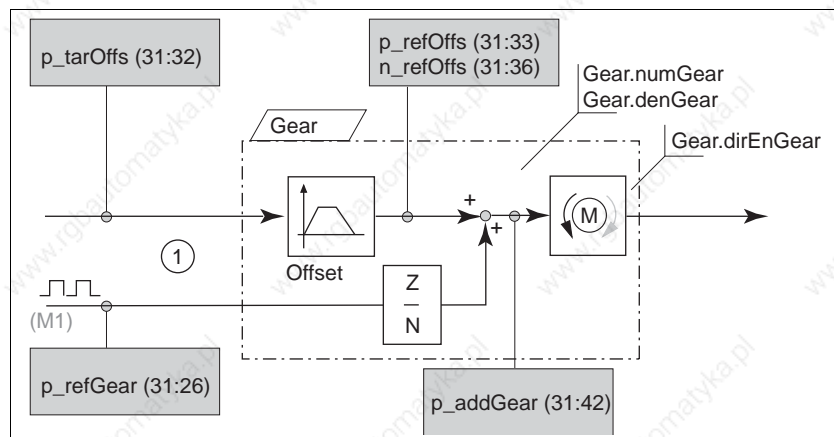

Figure 6.12 Supervision of offset positioning

0098 441 113 110, V1.00, 07.2004

Group.Name	Idx:Six dec (hex)	TLHMI	Explanation and unit []	Value range	Default value	R/W per.
Gear.p_absOffs	39:1 (27:1 _h)	3.1.3.6	Start of absolute offset positioning with transfer of position	INT32 -2147483648..2147483647	0	R/W-
Gear.stateOffs	39:2 (27:2 _h)	-	Acknowledgement: Offset positioning	UINT16 0..65535 Bit0: error LIMP Bit1: error LIMN Bit2: error HW_ STOP Bit3: error REF Bit5: error SW_LIMP Bit6: error SW_LIMN Bit7: error SW_STOP Bit13: offset setpoint position reached Bit14: offset_motion_end Bit15: offset_motion_err	-	R/- -
Gear.p_relOffs	39:3 (27:3 _h)	3.1.3.7	Start of relative offset positioning with transfer of travel value [inc]	INT32 -2147483648..2147483647	0	R/W-
Gear.n_tarOffs	39:5 (27:5 _h)	3.1.3.8	Setpoint speed of offset positioning [rpm]	INT32 1..12000	60	R/W-
Gear.phomeOffs	39:6 (27:6 _h)	3.1.3.9	Dimension setting in offset positioning [Inc]	INT32 -2147483648..2147483647	0	R/W-
Gear.accOffs	39:7 (27:7 _h)	3.1.3.10	Acceleration ramp for offset positioning [rev/(min*s)]	INT32 60..2000000	300	R/W-
Gear.decOffs	39:8 (27:8 _h)	3.1.3.11	Deceleration ramp for offset positioning [rev/(min*s)]	INT32 60..2000000	300	R/W-

6.6 Referencing



WARNING!

Danger of personal injury and damage to system parts by uncontrolled system operation!

- Note that inputs to these parameters are executed by the drive controller immediately on receipt of the data set.
- Make sure that the system is free and ready for movement before changing these parameters

Overview of referencing

In referencing, an absolute scale reference of the motor position at a defined axis position is established. Referencing can be carried out by a referencing movement or by dimension setting.

In a referencing movement, a defined position on the axis, the zero or reference point, is established as the absolute scale reference of the motor position to the axis. This reference point is used as the point of reference for all subsequent absolute positioning operations.

Dimension setting allows the current motor position to be defined as the new axis reference point to which all subsequent position data relate.



When a SinCos multiturn incremental encoder is used, the position value in the encoder is automatically set when it is switched on - meaning that referencing is not required. See 5.4.7 „Setting device parameters for rotary encoder“ for details on setting the position with the SinCos encoder.

The operating mode can be executed by

- TLHMI hand-held operating unit
- TLCT commissioning software
- Fieldbus

Operation with TLCT or TLHMI

The commissioning software and the HMI hand-held operating unit support this operating function with special dialog boxes and menu items. For details see the manuals for the commissioning software and the TLHMI hand-held operating unit.

Referencing with parameters

Referencing mode can be started with the field bus via two parameters:

- Reference movement via `Home.startHome`
- Dimension setting via `Home.startSetP`.

The parameter `Home.StateHome` provides information on the processing status.

A successful referencing is identified by the , "ref_ok" = 1 in parameter `Status.xMode_act`.

Group.Name	Idx:Six dec (hex)	TLHMI	Explanation and unit []	Value range	Default value	R/W per.
Status.xMode_act	28:3 (1C:3 _h)	2.3.5.5	Current axis mode with additional information, Bit0..4: For a list of possible operating modes for your TL unit see Chapter 'Operating modes'	UINT16 0..65535 Bit0..4: Current operating mode (device-specific) [For a list of possible operating modes for your TL device see Chapter "Operating modes"] 0: not used 1: manual positioning mode 2: referencing 3: PTP positioning 4: speed profile 5: electronic gear with offset adjustment, position-controlled (AC) or with position reference (SM) 6: electronic gear speed-controlled 7: data set mode 8: function generator (current controller) 9: function generator (speed controller) 10: function generator (position controller) 11..15: cannot be set 16: function generator in status disabled 17: current regulation 18: oscillator mode 19..30: reserved 31: do not use Bit5: drive is referenced ('ref_OK') Bit6: control deviation inside position window (SM: not assigned) Bit7: reserved Bit8..15: not assigned	–	R/- -

6.6.1 Reference movement

The controller provides four standard reference movements for selection.

- Movement to negative limit switch $\overline{\text{LIMN}}$
- Movement to positive limit switch $\overline{\text{LIMP}}$
- Movement to reference switch $\overline{\text{REF}}$ with first movement in negative direction of rotation
- Movement to reference switch $\overline{\text{REF}}$ with first movement in positive direction of rotation

The signals $\overline{\text{LIMN}}$, $\overline{\text{LIMP}}$ and $\overline{\text{REF}}$ required for the reference movement must be wired. Unused monitoring signals must be deactivated or connected to 24 V.

A reference movement must be completed for the new reference point to be valid. If it is interrupted, the reference movement must be started again. In contrast to the other operating modes, a reference movement must be completed before a new operating mode can be started.

The reference movement can be executed with or without an index pulse.

Search and clearance speeds and also safety gap and withdrawal path can all be set in user-defined units for the reference movement without index pulse.

Search and clearance speeds can also be set for reference movement with index pulse. However, clearance from the switching range is with an index pulse. The virtual index pulse is calculated depending on the direction of rotation of the servomotor. It is at the motor position at which the modulo position `Status.p_abs` takes the value 0 with reference to one motor revolution.

The REF switch does not have to be enabled for the reference movement.

The level of the reference switch $\overline{\text{REF}}$ can be reversed over Bit3 in the parameter `Settings.SignLevel`.

Additional setting options

The following additional parameters can be set in referencing mode:

- `Home.DefPosTyp`
- `Home.RefAppPos`.

If the speed or ramp setting is changed for withdrawal from the switching area, the end position of the reference movement may be changed. The parameter `Home.DefPosTyp` can be used to secure the motor position at the time of the signal change at the limit and reference switches. The precision of the position record is approximately equal to the position distance covered in 1 ms.

After successful completion of a reference movement the user-defined position (=zero point of the application) can be set to the reference point (= machine zero point) with the parameter `Home.RefAppPos`. To do this the negative position difference between reference position and user-defined position value is found and the calculated value set in the parameter `Home.RefAppPos`.

6.6.2 Reference movement without index pulse

The table below shows the parameters with which the reference movement without index pulse can be started, executed and acknowledged at the end or reference switch.

Group.Name	Idx:Six dec (hex)	TLHMI	Explanation and unit []	Value range	Default value	R/W per.
Home.startHome	40:1 (28:1 _h)	-	Start of referencing mode action object: A write access triggers a referencing	UINT16 1...8 1: LIMP 2: LIMN 3: REFZ neg. direction of rotation 4: REFZ pos. direction of rotation 5: LIMP with index pulse 6: LIMN with index pulse 7: REFZ neg. direction of rotation with index pulse 8: REFZ pos. direction of rotation with index pulse	-	R/W
Home.stateHome	40:2 (28:2 _h)	-	Acknowledgement: Referencing	UINT16 0..65535 Bit0: error LIMP Bit1: error LIMN Bit2: error HW_STOP Bit3: error REF Bit5: error SW_LIMP Bit6: error SW_LIMN Bit7: error SW_STOP Bit14: ref_end Bit15: ref_err	-	R/- -

Group.Name	Idx:Six dec (hex)	TLHMI	Explanation and unit []	Value range	Default value	R/W per.
Status.xMode_act	28:3 (1C:3 _h)	2.3.5.5	Current axis mode with additional information, Bit0..4: For a list of possible operating modes for your TL unit see Chapter 'Operating modes'	UINT16 0..65535 Bit0..4: Current operating mode (device-specific) [For a list of possible operating modes for your TL device see Chapter "Operating modes"] 0: not used 1: manual positioning mode 2: referencing 3: PTP positioning 4: speed profile 5: electronic gear with offset adjustment, position-controlled (AC) or with position reference (SM) 6: electronic gear speed-controlled 7: data set mode 8: function generator (current controller) 9: function generator (speed controller) 10: function generator (position controller) 11..15: cannot be set 16: function generator in status disabled 17: current regulation 18: oscillator mode 19..30: reserved 31: do not use Bit5: drive is referenced ('ref_OK') Bit6: control deviation inside position window (SM: not assigned) Bit7: reserved Bit8..15: not assigned	-	R/- -
Home.v_Home	40:4 (28:4 _h)	3.3.3	Speed for search of reference switch [usr]	INT32 -2147483648..2147483647	60	R/W per.
Home.v_outHome	40:5 (28:5 _h)	3.3.4	Speed for processing withdrawal path and safety distance [usr]	INT32 -2147483648..2147483647	6	R/W per.
Home.p_outHome	40:6 (28:6 _h)	3.3.5	Max. withdrawal path with activated reference switch [usr]	UINT32 0..2147483647 0: withdrawal control disabled > 0: Withdrawal path [usr]	0	R/W per.
Home.p_disHome	40:7 (28:7 _h)	3.3.6	Safety distance from switching edge to reference point [usr]	UINT32 0..2147483647	200	R/W per.

Group.Name	Idx:Six dec (hex)	TLHMI	Explanation and unit []	Value range	Default value	R/W per.
Home.RefSwMod	40:9 (28:9 _h)	3.3.10	Processing sequence with reference movement to REF	UINT16 0..3 Bit0: direction reversal at REF 0: permissible (standard mode) 1: not permissible Bit1: direction of movement safety distance 0: away from switch 1: into switch area	0	R/W per.
Home.DefPosTyp	40:10 (28:A _h)	-	Reference position for processing safety distance and index pulse search	UINT16 0 .. 1 0 : setpoint position at standstill after deceleration as a result of signal change at limit or reference switch 1: Save current motor position on signal change at limit or reference switch	0	R/W per.
Home.RefAppPos	40:11 (28:B _h)	-	Application position at reference point [usr]	INT32 -2146483648.. +2146483647	0	R/W per.

Reference movement towards limit switch without index pulse

A reference movement to the negative limit switch with additional safety distance is shown below:
The reference point is "R-".

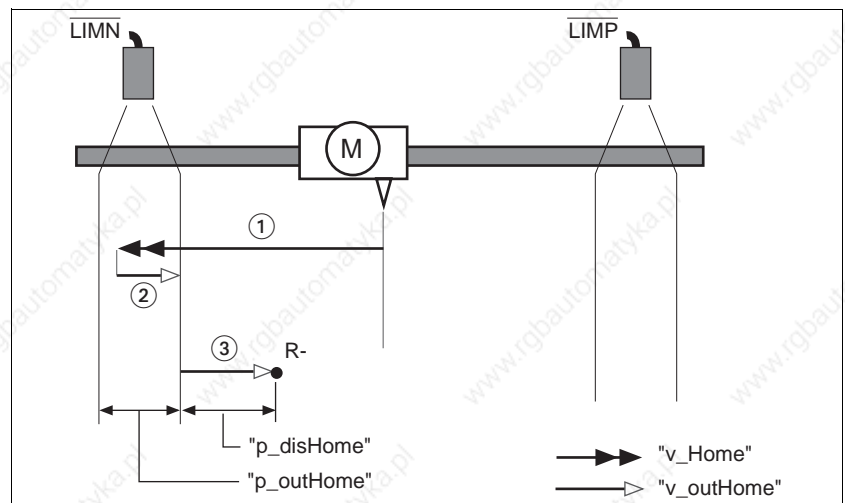

Figure 6.13 Reference movements to limit switch with movement to safety distance

- 1 movement at search speed Home.v_{Home}
- 2 movement to switching edge at clearance speed Home.v_{outHome}
- 3 movement to clearance Home.p_{disHome} at clearance speed.
- Movement to the reference switch with first movement in negative direction, REF switch is pending once (A1, A2), once behind start point (B1, B2), reference point is "R-"

Reference movement to limit switch without index pulse

- Additional movements when travelling through switching window (A2, B2).

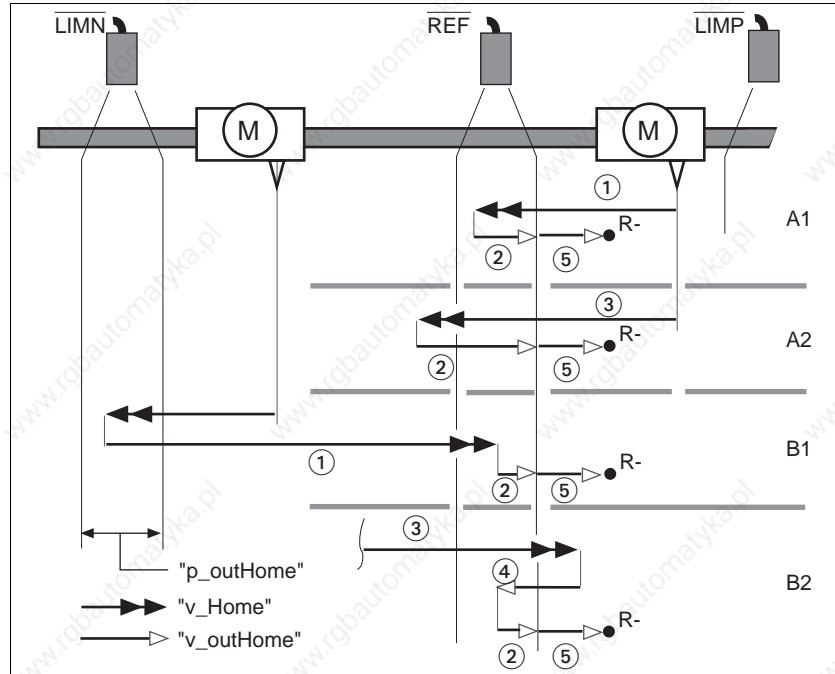

Figure 6.14 Reference movement to reference switch with first movement in negative sense of rotation

- 1 movement at search speed $Home.v_Home$ to the reference switch
- 2 movement to switching edge at clearance speed $Home.v_outHome$
- 3 movement too fast at search speed to reference switch
- 4 return movement at clearance speed in switch range
- 5 movement to clearance $Home.p_disHome$ at clearance speed.

Special setting options with reference movement to REF

During the reference movement to REF $Home.RefSwMod$ can specify whether a direction reversal is permissible and whether a movement should be executed to the safety area.

Group.Name	Idx:Six dec (hex)	TLHMI	Explanation and unit []	Value range	Default value	R/W per.
Home.RefSwMod	40:9 (28:9 _h)	3.3.10	Processing sequence with reference movement to REF	UINT16 0..3 Bit0: direction reversal at REF 0: permissible (standard mode) 1: not permissible Bit1: direction of movement safety distance 0: away from switch 1: into switch area	0	R/W per.

This yields the following four cases:

- Case A: Bit0 = 0 and Bit1 = 0 [standard/default setting], i.e. direction reversal at REF is permissible the safety distance movement is executed away from the switch.

- Case B: Bit0 = 1 and Bit1 = 0, i.e. direction reversal at REF is not permissible the safety distance movement is executed away from the switch.
- Case C: Bit0 = 0 and Bit1 = 1, i.e. direction reversal at REF is permissible and the safety distance movement is executed into the switch range.
- Case D: Bit0 = 1 and Bit1 = 1, i.e. direction reversal at REF is not actually permissible and the safety distance movement is executed into the switch range. However, an automatic direction reversal takes place when processing the safety distance because of this setting.

The following diagram shows the special setting options with Home.RefSwMod.

Example: Reference movement to REF in negative rotation direction without index pulse

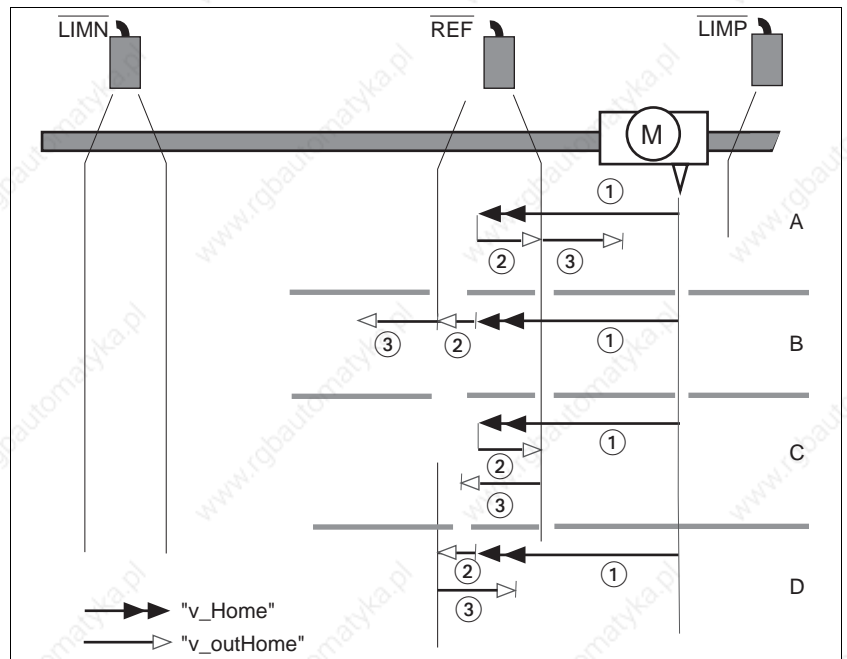

Figure 6.15 Settings of Home.RefSwMod

Options for reference movement to reference switch depending on the setting of Home.RefSwMod with first movement in negative direction of rotation:

- 1 movement at search speed Home.v_Home to switch
- 2 movement to switching edge at clearance speed Home.v_outHome
- 3 movement safety distance

6.6.3 Reference movement with index pulse

Requirement with position control at M2 Use of actual position encoder at M2, SinCos or resolver type
 Setting a new absolute position with the SinCos single turn can set the position of the virtual index pulse, see page 5-21

Requirement with position control at M1 If the position control at M1 is enabled, the index pulse reference movement is executed to the physical index pulse of the position encoder at M1.

First, the defined reference switch is approached and finally a search movement is made to the nearest physical index pulse.

The table below shows the parameters with which the reference movement with index pulse can be started, executed and acknowledged at the limit or reference switch.

Availability This function is available in controllers from software version 1.205.

Group.Name	Idx:Six dec (hex)	TLHMI	Explanation and unit []	Value range	Default value	R/W per.
Home.startHome	40:1 (28:1 _h)	-	Start of referencing mode action object: A write access triggers a referencing	UINT16 1...8 1: LIMP 2: LIMN 3: REFZ neg. direction of rotation 4: REFZ pos. direction of rotation 5: LIMP with index pulse 6: LIMN with index pulse 7: REFZ neg. direction of rotation with index pulse 8: REFZ pos. direction of rotation with index pulse	-	R/W
Home.stateHome	40:2 (28:2 _h)	-	Acknowledgement: Referencing	UINT16 0..65535 Bit0: error LIMP Bit1: error LIMN Bit2: error HW_STOP Bit3: error REF Bit5: error SW_LIMP Bit6: error SW_LIMN Bit7: error SW_STOP Bit14: ref_end Bit15: ref_err	-	R/-

Group.Name	Idx:Six dec (hex)	TLHMI	Explanation and unit []	Value range	Default value	R/W per.
Status.xMode_act	28:3 (1C:3 _h)	2.3.5.5	Current axis mode with additional information, Bit0..4: For a list of possible operating modes for your TL unit see Chapter 'Operating modes'	UINT16 0..65535 Bit0..4: Current operating mode (device-specific) [For a list of possible operating modes for your TL device see Chapter "Operating modes"] 0: not used 1: manual positioning mode 2: referencing 3: PTP positioning 4: speed profile 5: electronic gear with offset adjustment, position-controlled (AC) or with position reference (SM) 6: electronic gear speed-controlled 7: data set mode 8: function generator (current controller) 9: function generator (speed controller) 10: function generator (position controller) 11..15: cannot be set 16: function generator in status disabled 17: current regulation 18: oscillator mode 19..30: reserved 31: do not use Bit5: drive is referenced ('ref_OK') Bit6: control deviation inside position window (SM: not assigned) Bit7: reserved Bit8..15: not assigned	–	R/- -
Home.v_Home	40:4 (28:4 _h)	3.3.3	Speed for search of reference switch [usr]	INT32 -2147483648..2147483647	60	R/W per.
Home.v_outHome	40:5 (28:5 _h)	3.3.4	Speed for processing withdrawal path and safety distance [usr]	INT32 -2147483648..2147483647	6	R/W per.
Home.p_outHome	40:6 (28:6 _h)	3.3.5	Max. withdrawal path with activated reference switch [usr]	UINT32 0..2147483647 0: withdrawal control disabled > 0: Withdrawal path [usr]	0	R/W per.
Status.p_diffind	31:48 (1F:30 _h)	–	Distance between switch and index pulse after reference movement [Inc]	INT32 -2147483648.. 2147483647	–	R/- -

Group.Name	Idx:Six dec (hex)	TLHMI	Explanation and unit []	Value range	Default value	R/W per.
Home.RefSwMod	40:9 (28:9 _h)	3.3.10	Processing sequence with reference movement to REF	UINT16 0..3 Bit0: direction reversal at REF 0: permissible (standard mode) 1: not permissible Bit1: direction of movement safety distance 0: away from switch 1: into switch area	0	R/W per.
Home.DefPosTyp	40:10 (28:A _h)	-	Reference position for processing safety distance and index pulse search	UINT16 0 .. 1 0 : setpoint position at standstill after deceleration as a result of signal change at limit or reference switch 1: Save current motor position on signal change at limit or reference switch	0	R/W per.
Home.RefAppPos	40:11 (28:B _h)	-	Application position at reference point [usr]	INT32 -2146483648.. +2146483647	0	R/W per.

Search range for index pulse at position sensor M1

The search range between reference switch edge and index pulse signal can be set with a new user parameter. The default setting is a search range of +2147483647 increments. After leaving the reference or limit switch at which the reference movement was triggered, it waits for an index pulse within the configured range. If it does not occur, the reference movement is interrupted with an error.

The parameter is available only if slot M1 has an RS422 module and the external position control is activated at M1.

The nearest index pulse is always approached after leaving the limit or reference switch.

Group.Name	Idx:Six dec (hex)	TLHMI	Explanation and unit []	Value range	Default value	R/W per.
Home.p_SrchIdx	40:12 (28:C _h)	-	Search range index pulse with position control at M1 This is only used with referencing at index pulse when the position control is installed at M1. [Inc]	INT32 1...2147483647	2147483647	R/W

Reference movement towards limit switch with index pulse

Index pulse position: First position at which `Status.p_abs` takes the value 0 after leaving the mechanical switch.

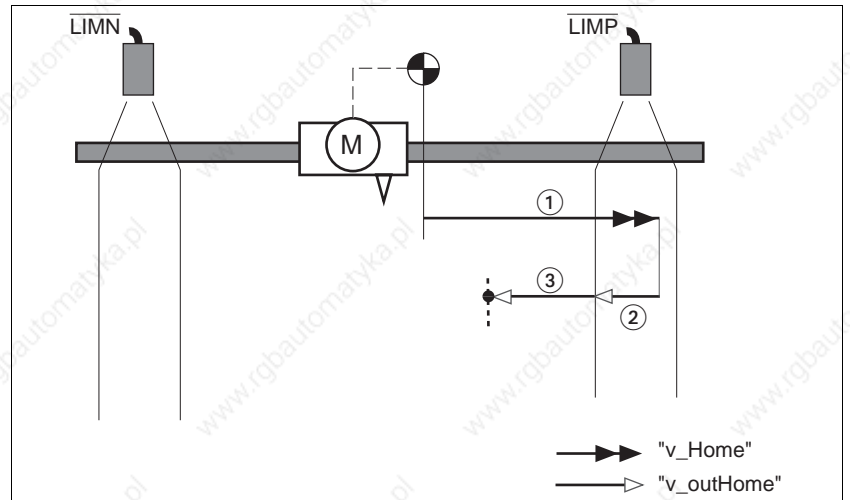

Figure 6.16 Reference movement towards limit switch

- 1 movement at search speed `Home.v_Home` to the LIMP limit switch
- 2 movement to switching edge at clearance speed `Home.v_outHome`
- 3 movement to index pulse at clearance speed.

Reference movement to limit switch with index pulse

- Movement to the reference switch with first movement in negative direction, \overline{REF} switch is there once (A1, A2), once behind starting point (B1, B2)

- Additional movements when travelling through switching window (A2, B2).

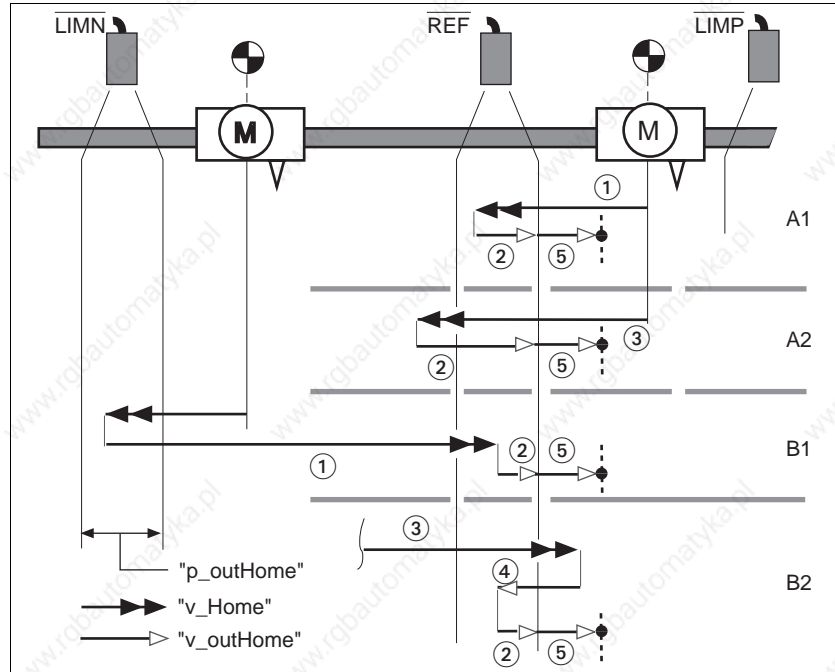

Figure 6.17 Reference movement to reference switch with first movement in negative sense of rotation

- 1 movement at search speed $Home.v_Home$ to the reference switch
- 2 movement to switching edge at clearance speed $Home.v_outHome$
- 3 movement too fast at search speed to reference switch
- 4 return movement at clearance speed in switch range
- 5 movement to index pulse at clearance speed.

Special setting options with reference movement to REF

During the reference movement to REF $Home.RefSwMod$ can be used to set whether direction reversal is permissible.

Group.Name	Idx:Six dec (hex)	TLHMI	Explanation and unit []	Value range	Default value	R/W per.
Home.RefSwMod	40:9 (28:9 _h)	3.3.10	Processing sequence with reference movement to REF	UINT16 0..3 Bit0: direction reversal at REF 0: permissible (standard mode) 1: not permissible Bit1: direction of movement safety distance 0: away from switch 1: into switch area	0	R/W per.

This yields the following cases:

- Case A: Bit0 = 0 [standard/default setting], i.e. direction reversal at REF is permissible.

- Case B: Bit0 = 1,
i.e. direction reversal at REF is not permissible.

The following diagram shows the special setting options with `Home.RefSwMod`. Example: Reference movement to REF in negative rotation direction with index pulse

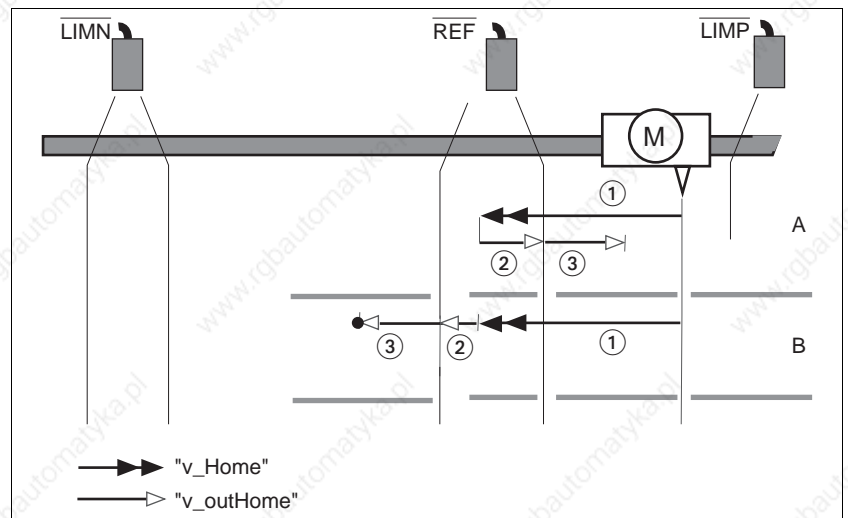

Figure 6.18 Settings of `Home.RefSwMod`

Options for reference movement to reference switch depending on the setting of `Home.RefSwMod` with first movement in negative direction of rotation:

- 1 movement at search speed `Home.v_Home` to switch
- 2 movement to switching edge at clearance speed `Home.v_outHome`
- 3 movement to index pulse.

6.6.4 Referencing by dimension setting

Referencing by dimension setting moves the reference point for set-points to the new scale position. The position value is transferred in user-defined units in parameter `Home.startSetp`.

Referencing by dimension setting can only be carried out when the motor is at a standstill. Any active position deviation is retained and can still be compensated by the position controller after dimension setting has taken place.

Group.Name	Idx:Six dec (hex)	TLHMI	Explanation and unit []	Value range	Default value	R/W per.
Home.startSetp	40:3 (28:3 _h)	3.3.2	Sizing on sizing position (set absolute position) [usr]	INT32 -2147483648..2147483647	-	R/W-
Home.stateHome	40:2 (28:2 _h)	-	Acknowledgement: Referencing	UINT16 0..65535 Bit0: error LIMP Bit1: error LIMN Bit2: error HW_STOP Bit3: error REF Bit5: error SW_LIMP Bit6: error SW_LIMN Bit7: error SW_STOP Bit14: ref_end Bit15: ref_err	-	R/- -

Group.Name	Idx:Six dec (hex)	TLHMI	Explanation and unit []	Value range	Default value	R/W per.
Status.xMode_act	28:3 (1C:3 _h)	2.3.5.5	Current axis mode with additional information, Bit0..4: For a list of possible operating modes for your TL unit see Chapter 'Operating modes'	UINT16 0..65535 Bit0..4: Current operating mode (device-specific) [For a list of possible operating modes for your TL device see Chapter "Operating modes"] 0: not used 1: manual positioning mode 2: referencing 3: PTP positioning 4: speed profile 5: electronic gear with offset adjustment, position-controlled (AC) or with position reference (SM) 6: electronic gear speed-controlled 7: data set mode 8: function generator (current controller) 9: function generator (speed controller) 10: function generator (position controller) 11..15: cannot be set 16: function generator in status disabled 17: current regulation 18: oscillator mode 19..30: reserved 31: do not use Bit5: drive is referenced ('ref_OK') Bit6: control deviation inside position window (SM: not assigned) Bit7: reserved Bit8..15: not assigned	–	R/- -

Example Dimension setting can be used to carry out a continuous motor movement without exceeding positioning limits.

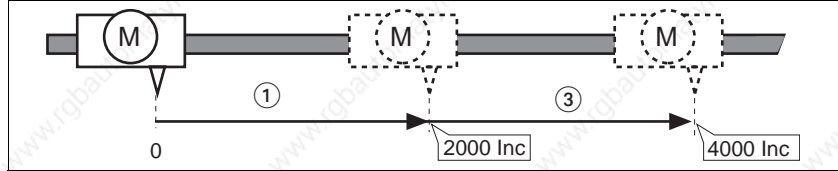

Figure 6.19 Positioning by 4000 increments without dimension setting.

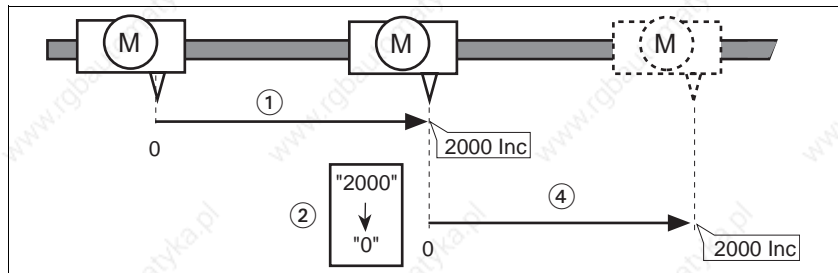

Figure 6.20 Positioning by 4000 increments with dimension setting.

- 1 At the start to the reference point the motor positions 2000 Inc.
- 2 By calling the referencing by dimension setting the current position is set to the dimension setting position in user-defined units.
- 3 After triggering a new movement command by 2000 Inc the new target position without dimension setting is 4000 Inc.
- 4 After triggering a new movement command by 2000 Inc the new target position with dimension setting is 2000 Inc.

This method avoids crossing absolute position limits during a positioning operation because the zero point is continuously tracked.

6.7 Current control

Overview of current control

In current control, the setpoint value of the motor current can be set either with parameters or the $\pm 10V$ input of the signal interface.

The operating mode can be executed by:

- TLCT Commissioning Software
- Fieldbus

Operation with TLCT commissioning software

The TLCT commissioning software supports this operating mode with special dialogues and menus. For details see the manual for the TLCT commissioning software.

Overview

The following overview shows how the parameters that can be set in the current control mode operate.

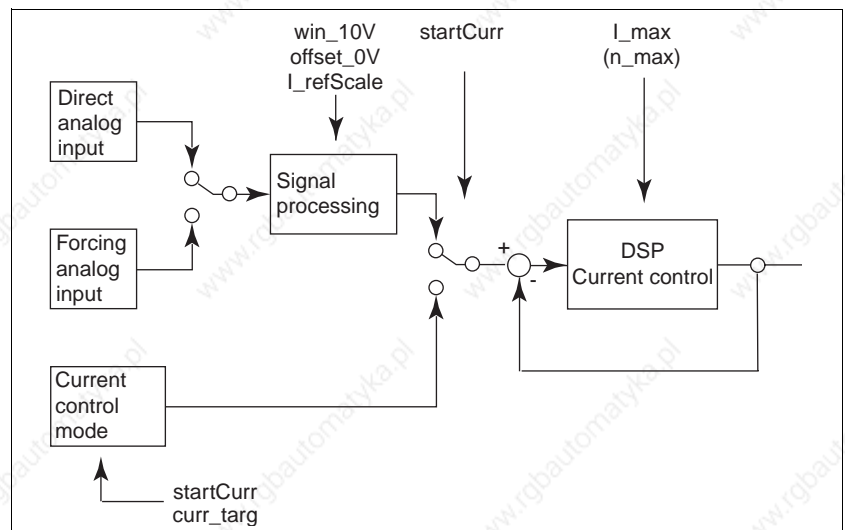

Figure 6.21 Overview of how the variable parameters in current control mode operate

Start current control

The parameter `CurrentControl.startCurr` is used to set the current control mode.

Group.Name	Idx:Six dec (hex)	TLHMI	Explanation and unit []	Value range	Default value	R/W per.
CurrentControl.startCurr	50:1 (32:1 _n)	3.1.8.1	Starting current control	UINT16 0..2 0: disabled 1: setpoint value over +/-10V interface 2: Setpoint with parameter (CurrentControl.curr_targ)	-	R/W-

Acknowledge current control

The parameter `CurrentControl.stateCurr` provides information on the processing status in current control mode. Processing in current control mode is completed when either the operating mode has been "disabled" and the drive is stationary or when the motor speed has the value = 0 as the result of an error.

Group.Name	Idx:Six dec (hex)	TLHMI	Explanation and unit []	Value range	Default value	R/W per.
CurrentControl.stateCurr	50:2 (32:2 _h)	–	Acknowledgement: Current control mode.	UINT16 0..65535 Bit0: error LIMP Bit1: error LIMN Bit2: error HW_STOP Bit3: error REF Bit4: not assigned Bit5: SW_LIMP Bit6: SW_LIMN Bit7: SW_STOP Bit8-Bit12: not assigned Bit13: curr_ctrl_nact_zero 0: motor speed <> 0 1: motor speed = 0 Bit14: curr_ctrl_end 0: Process active 1: Process inactive Bit15: curr_ctrl_err 0: noerror 1: Error	–	R/- -

Current limitation To protect the drive system the current limiting must be adapted to the attached drive system with two parameters `CtrlBlock1.I_max` and `CtrlBlock2.I_max`, see 5.4.5 „Setting device parameters“ on page 5-13.

Speed limitation The two parameters `CtrlBlock1.n_max` and `CtrlBlock2.n_max` can be used to adapt the speed limiter to protect the drive system, see 5.4.5 „Setting device parameters“ on page 5-13.

Options for current control The current setpoint can be set directly with the parameter `CurrentControl.curr_targ` or indirectly with the $\pm 10V$ analogue input of the signal interface.

The curve of the setpoint current depending on the $\pm 10V$ input value can be changed with:

- Preprocessing the analogue value using an offset or a voltage window
- Setting the setpoint current at 10 V.

Setpoint current for current control The parameter `CurrentControl.curr_targ` can be used for direct setting of the current setpoint. The value is limited internally by the maximum current of the power amplifier or the motor current.

Group.Name	Idx:Six dec (hex)	TLHMI	Explanation and unit []	Value range	Default value	R/W per.
CurrentControl.curr_targ	50:3 (32:3 _h)	3.1.8.2	Current setpoint for current control For control over field bus (=FB) this applies: (100 = 1Apk) For other control (\neq FB) this applies: [Apk]	INT16 -32768..+32767 for other: -327.68..+327.67	0	R/W-

Setpoint current with 10 V input signal

The controller uses the $\pm 10\text{V}$ analogue value preset to calculate a current with which the motor accelerates to a speed limited by the load torque. Without a load the motor therefore accelerates to the variable speed limit.

**WARNING!**

Unexpected acceleration may cause injury and damage to the system.

The drive in current regulation mode can reach extreme speeds when operated without limits or load.

- Check the configured speed limiter.

The current setpoint for a voltage value of 10 V can be set via the `Settings.I_RefScal` scaling value.

Group.Name	Idx:Six dec (hex)	TLHMI	Explanation and unit []	Value range	Default value	R/W per.
Settings.I_RefScal	12:3 (C:3 _h)	4.1.20	Setpoint current at 10V input signal For control by field bus (=FB) this applies: (100=1A _{pk}) For other types of control (\neq FB) this applies: [A _{pk}]	UINT16 0..max. Current 0..32767 0..327.67	300	R/W per.

Analogue value offset

The parameter `Settings.offset_0V` can be used to vary the offset for the $\pm 10\text{V}$ input, which changes the relationship between input voltage and current setpoint.

Group.Name	Idx:Six dec (hex)	TLHMI	Explanation and unit []	Value range	Default value	R/W per.
Settings.offset_0V	20:58 (14:3A _h)	4.1.38	Offset for linear shift of the 0V input voltage [mV]	INT16 -5000.. +5000	0	R/W per.

Small deviations in the zero area can be compensated with the analogue value offset.

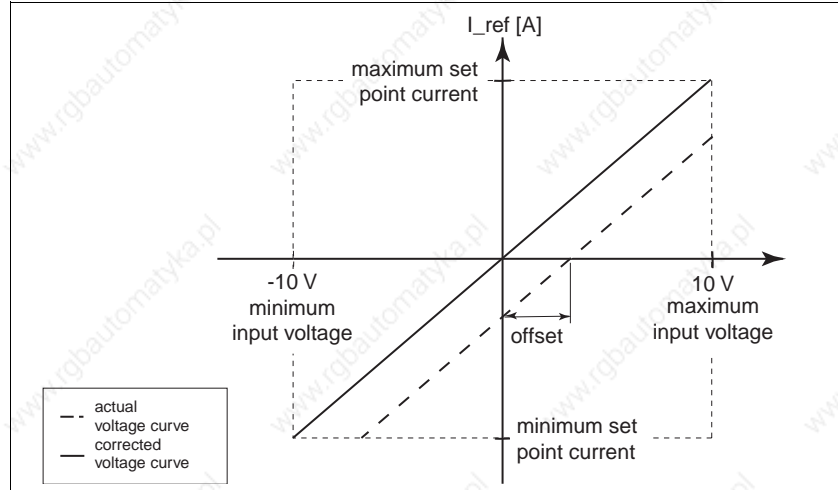

Figure 6.22 Analogue value offset for the ±10 V input

Analogue value voltage window

An analogue value voltage window can be configured for the ±10V input with `Settings.win_10V` in which the current setpoint takes the value 0.

Group.Name	Idx:Six dec (hex)	TLHMI	Explanation and unit []	Value range	Default value	R/W per.
Settings.win_10V	20:59 (14:3B _h)	4.1.39	Voltage window within which is analogue value is equal to 0 [mV] Example: Setting value of 20 mV means that the range - 20 mV to + 20 mV is interpreted as 0 mV	UINT16 0..1000	0	R/W per.

As soon as the range of the voltage window is left, a setpoint value $\neq 0$ is generated.

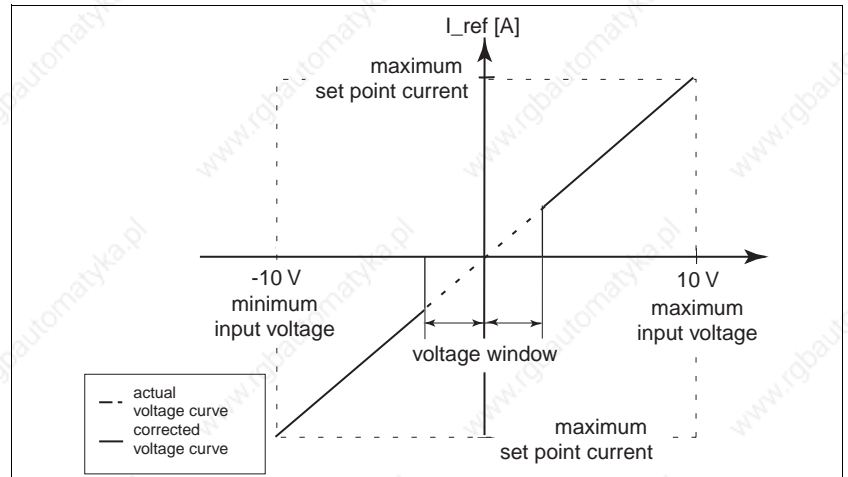

Figure 6.23 Analogue value voltage window around the value 0 V for the ± 10 V input

Information on additional settings

For the signals that trigger a Quick-Stop the parameter `Settings.SiggnQStop` can be set to specify whether the process should be interrupted by the QuickStop current `Settings.I_maxStop` or or `CtrlBlock1.I_max` and `CtrlBlock2.I_max`. For more information on setting options see the chapter 7.5 „Quick-Stop function“ on page 7-20.

List data cannot be processed and direction inversion is not possible in current regulation mode.

6.8 Oscillator mode

Overview of oscillator mode

In oscillator mode the motor is moved in accordance with a voltage-dependent preset via the ± 10 Volt input.

When the input voltage is changed the drive accelerates or decelerates to the new setpoint speed with the specified acceleration and deceleration values.

The operating mode can be executed by:

- TLCT Commissioning Software
- Fieldbus

Operation with TLCT commissioning software

The TLCT commissioning software supports this operating mode with special dialogues and menus. For details see the manual for the TLCT commissioning software.

Overview

The following structural view shows the effects of the parameters on the setpoint speed, which can be set in oscillator mode.

When the input voltage is changed the drive accelerates or decelerates to the new setpoint speed with the specified acceleration and deceleration values set with `Motion.acc` and `Motion.dec`.

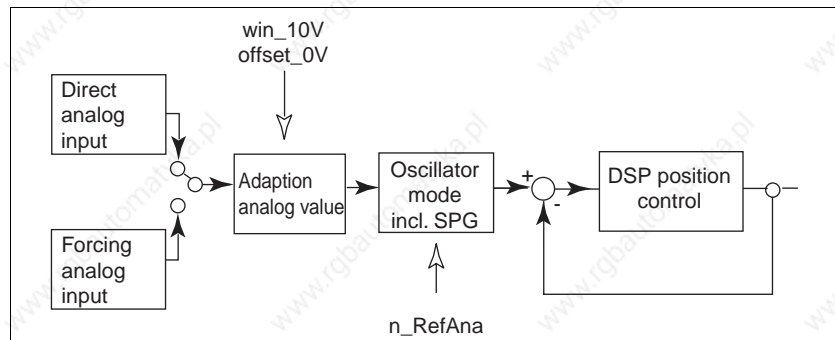

Figure 6.24 Overview of how the variable parameters in oscillator mode operate

Starting oscillator mode

The parameter `Oscillator.startOszi` is used to set the oscillator mode.

Group.Name	Idx:Six dec (hex)	TLHMI	Explanation and unit []	Value range	Default value	R/W per.
Oscillator.startOszi	51:1 (33:1 _h)	3.1.9.1	Starting oscillator mode	UINT16 0..2 0: disabled (setpoint value=0) 1: Setpoint via ± 10 V interface	0	R/W-

Acknowledging oscillator mode

The parameter `Oscillator.stateOszi` provides information on the processing status in oscillator mode. Processing in current regulation mode is completed when either the operating mode has been "disabled" and the drive is stationary or when the motor speed has the value = 0 as the result of an error.

Group.Name	Idx:Six dec (hex)	TLHMI	Explanation and unit []	Value range	Default value	R/W per.
Oscillator.stateOszi	51:2 (33:2 _h)	–	Acknowledgement: Oscillator mode	UINT16 0..65535 Bit0: error LIMP Bit1:error LIMN Bit2: error HW_STOP Bit3: error REF Bit4: not assigned Bit5: error SW_LIMP Bit6: error SW_LIMN Bit7: error SW_STOP Bit8-Bit12: not assigned Bit13: setpoint speed reached 0: actual speed ¼ setpoint speed 1:actual speed = setpoint speed Bit14: oscillator_end 0: Process active 1: Process inactive Bit15: oscillator_err 0: no error 1: Error	–	R/- -

Options for speed control The curve of the setpoint speed can be changed depending on the ± 10 V analogue input value with:

- Setting the setpoint speed at 10 V
- Preprocessing the analogue value using an offset or a voltage window

Setpoint speed at 10 V input signal The parameter `Oscillator.n_RefAna` can be used to specify the setpoint speed for a 10V input signal.

Group.Name	Idx:Six dec (hex)	TLHMI	Explanation and unit []	Value range	Default value	R/W per.
Oscillator.n_RefAna	51:3 (33:3 _h)	3.1.9.2	Setpoint speed at +10 V input signal [rpm]	UINT16 0 .. 13200 (note: max. motor speed must not be exceeded)	3000	R/W per.

Analogue value offset The parameter `Settings.offset_0V` can be used to vary the offset for the ± 10 V input, which changes the relationship between input voltage and speed.

Group.Name	Idx:Six dec (hex)	TLHMI	Explanation and unit []	Value range	Default value	R/W per.
Settings.offset_0V	20:58 (14:3A _h)	4.1.38	Offset for linear shift of the 0V input voltage [mV]	INT16 -5000.. +5000	0	R/W per.

Small deviations in the zero area can be compensated with the user offset.

The diagram below shows this more clearly:

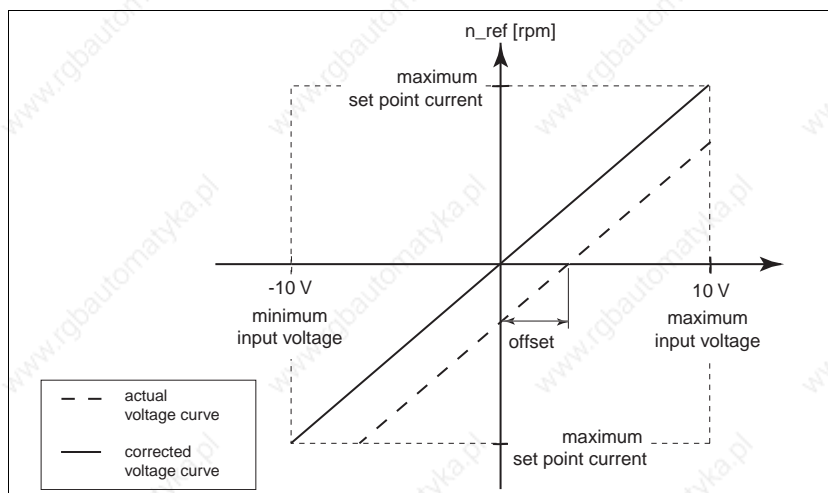

Figure 6.25 User value offset for the ±10 V input

Analogue value voltage window

An analogue value voltage window can be configured for the ± 10V input with `Settings.win_10V` in which the speed setpoint takes the value 0.

Group.Name	Idx:Six dec (hex)	TLHMI	Explanation and unit []	Value range	Default value	R/W per.
Settings.win_10V	20:59 (14:3B _h)	4.1.39	Voltage window within which is analogue value is equal to 0 [mV] Example: Setting value of 20 mV means that the range - 20 mV to + 20 mV is interpreted as 0 mV	UINT16 0..1000	0	R/W per.

As soon as the range of the analogue value voltage window is left, a set-point value $\neq 0$ is generated.

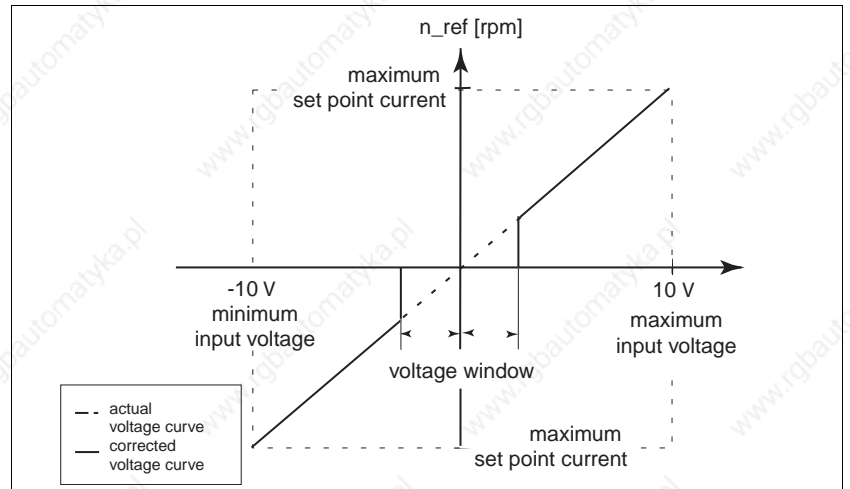

Figure 6.26 Analogue value voltage window around the value 0 V for the ± 10 V input

Information on additional settings List data for a position/speed list cannot be processed oscillator mode.

7 Functions of the controller

7.1 List control and list processing

Overview List control is an operation that runs in the background while a movement command is being processed. If the motor reaches an axis position that is saved in the list, a new speed value is activated or an interface signal is changed.

The controller saves two separate lists with 64 list fields each for position entries. A list type must be specified before input of values.

Position/speed list

- A speed value is stored for every position entry
- Operates in
 - speed mode
 - point-to-point mode
- Comparison value: `Status.p_jerkusr`

Position/signal list

- A signal level is stored for every position entry which will be set the state of the output TRIGGER.
- Operates in
 - manual movement
 - speed mode
 - point-to-point mode
 - electronic gear
 - oscillator mode
- Comparison value: `Status.p_actusr`

I/O signal	Function	Value
TRIGGER	Output signal switched by a position/signal list	0 / open

The precision of the time at which the controller sets the output signal depends on various factors that in turn depend on the hardware and software. See „Triggering accuracy“ on page 7-5.

Starting list-controlled operation

List-controlled operation can be started with

- hand-held operating unit
- Commissioning software
- Field bus

List-controlled operation is started by selecting the list and a starting number in the range between the first and last number. If an operating

mode is activated, the controller changes the state of the output TRIGGER or the speed value in the event of a matching list and axis position.

The list can be changed during a running operation by selecting the inactive list. List processing can be interrupted at any point in the positioning process by deactivating the current list.

When the specified finishing number is reached, list-controlled operation is stopped. To restart it, it is only necessary to select the list; the start and end position and list entries remain set.

Monitoring list-controlled operation

The processing status of the list-controlled mode can be evaluated via two parameters. Bit14, "list_quit" of the parameter List.stateList provides global information on the status of the function:

- 0: list-controlled mode active
- 1: List-controlled mode completed

The parameter List.actList provides detailed information on the processing status. It displays the last activated list position.

- -1: no list entry activated yet
- 0 ... 63: last activated entry

Group.Name	Idx:Six dec (hex)	TLHMI	Explanation and unit []	Value range	Default value	R/W per.
List.startList	44:1 (2C:1 _h)	3.1.5.1 3.1.5.2 3.1.6.1 3.1.6.2	Activate new list control	UINT16 0..2 0 :no list active 1 : List 1 2 : List 2	0	R/W-
List.stateList	44:2 (2C:2 _h)	-	Acknowledgement and status: List control	UINT16 0..65535 Bit15: list_err Bit14: list_quit 0: list-controlled mode active 1: list-controlled mode completed Bit 0,1: - 0 : no list active - 1 : list 1 active - 2 : list 2 active	-	R/- -
List.actList	44:18 (2C:12 _h)	-	List: activated processing number	INT16 -1..63 -1: still no list entry activated 0..63: last activated list entry range preset by start and end number of the list control	-1	R/- -
List.cntList1	44:4 (2C:4 _h)	-	List 1: number of available list entries	UINT16 0..64	64	R/- -
List.bgnList1	44:6 (2C:6 _h)	-	List 1: starting number of the list control end number > = starting number	UINT16 0..63	0	R/W per.
List.endList1	44:7 (2C:7 _h)	-	List 1: end number of the list control end number > = starting number	UINT16 0..63	63	R/W per.
List.cntList2	44:12 (2C:C _h)	-	List 2: number of available list entries	UINT16 0..64	64	R/- -

0098 441 113 110, V1.00, 07.2004

Group.Name	Idx:Six dec (hex)	TLHMI	Explanation and unit []	Value range	Default value	R/W per.
List.bgnList2	44:14 (2C:E _h)	–	List 2: starting number of the list control end number > = starting number	UINT16 0..63	0	R/W per.
List.endList2	44:15 (2C:F _h)	–	List 2: end number of the list control end number > = starting number	UINT16 0..63	63	R/W per.

Processing list entries

List entries of the non-active list can be changed before and during list-controlled operation by TLHMI, TLCT, manually with field bus or with the Teach-In processing.

When changing list values, please note the following:

- The controller saves the values for position and speed in user-defined units.
- List entries are selected via list numbers and evaluated in ascending order. Position entries within the range defined by the starting and finishing numbers must be entered in their correct ascending or descending order in the same way.
- The assigned list type applies for the whole list. The list type cannot be changed within a list.

The entries of both lists can be accessed through the parameter groups L1Data0 to L1Data63 for list 1 and L2Data0 to L2Data63 for list 2.

Group.Name	Idx:Six dec (hex)	TLHMI	Explanation and unit []	Value range	Default value	R/W per.
L1Data0.typeList1	1100:1 (44C:1 _h)	7.3.1.1	List 1: list type for ALL following list entries (1101:x...1163:x)	UINT16 1..2 1: Pos./signal 2: Pos./speed	1	R/W per.
L1Data0.posList1	1100:2 (44C:1 _h)	7.3.2.1 7.3.2.2	List 1: Position [usr]	INT32 -2147483648..2147483647	0	R/W per.
L1Data0.signList1	1100:3 (44C:1 _h)	7.3.2.3	List 1: signal state	UINT16 0, 1	0	R/W per.
L1Data0.velList1	1100:4 (44C:1 _h)	7.3.2.4	List 1: setpoint speed [usr]	INT32 -2147483648..2147483647 -'Motion.n_max0' .. +'Motion.n_max0' setting depends on PTP operating mode : 0: PTP.Vtarget; <>0: Amount of the saved value VEL: 0: VEL.velocity; <>0: Amount of the saved value	0	R/W per.
L2Data0.typeList2	1200:1 (4B0:1 _h)	7.4.1.1	List 2: list type for all following list entries (1201:x...1263:x)	UINT16 1..2 1: Pos./signal 2: Pos./speed	1	R/W per.

Group.Name	Idx:Six dec (hex)	TLHMI	Explanation and unit []	Value range	Default value	R/W per.
L2Data0.posList2	1200:2 (4B0:1 _h)	7.4.2.1 7.4.2.2	List 2: Position [usr]	INT32 -2147483648..2147483647	0	R/W per.
L2Data0.signList2	1200:3 (4B0:1 _h)	7.4.2.3	List 2: signal state	UINT16 0..1	0	R/W per.
L2Data0.velList2	1200:4 (4B0:1 _h)	7.4.2.4	List 2: setpoint speed [usr]	INT32 -2147483648..2147483647 -'motion.n_max0' .. 'Motion.n_max0' setting depends on PTP operating mode: 0: PTP.Vtarget; <>0: Amount of the saved value VEL: 0: VEL.velocity; <>0: Amount of the saved value	0	R/W per.

Example of position/signal list

The list control starts with a point-to-point positioning from the reference point to the 510 mm position at the speed of 100 rpm. The positioning standardisation is set so 1 user-defined unit equals 1 mm.

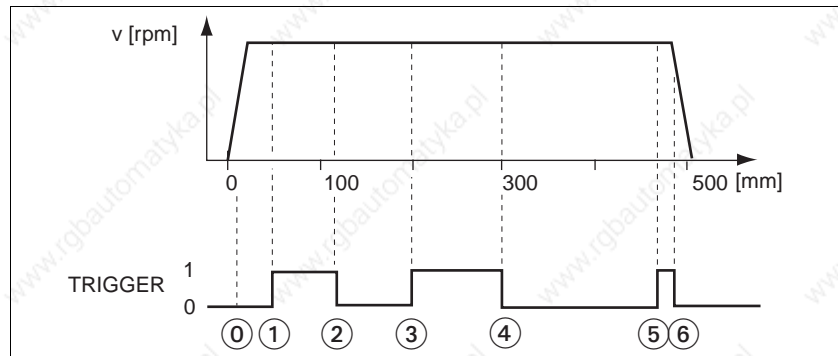

Figure 7.1 Positioning with position/signal list

- ▶ Activate position/signal list with `L1Data0.typeList1 = 1`.
- ▶ Input position values of the list between starting and end position into list 1.

Activated list excerpt for the example:

Graph point	List number 1100:x...1163:x	List type 1xxx:1	Position 1xxx:2	Trigger signal 1xxx:3	Speed 1xxx:4
0	1100	1	10	0	0
1	1101	1	50	1	0
2	1102	1	120	0	0
3	1103	1	200	1	0
4	1104	1	300	0	0
5	1105	1	470	1	0
6	1106	1	490	0	0
-	0	0

Column "Speed" has no significance for list control with the position/signal list.

- ▶ Starting position list number 0 with `List.bgnList1 = 0` (list no.1100.x)
- ▶ End position list number 6 with `List.endList1 = 6` (list no.1106.x)
- ▶ Activate list 1 with `List.startList = 1`
- ▶ Start positioning.

The trigger signal is changed when the position from the list corresponds to the current position of the motor encoder.

Triggering the trigger signal

Two successive trigger signals must be at least 3 ms apart. Smaller time distances are possible, but then the trigger signal may be delayed by several milliseconds.

Triggering accuracy

The time at which the trigger signal is switched is scattered around values that are influenced by factors dependent on hardware and software.

- Determined by hardware causes such as temperature, power supply or output load:
Jitter: max. +/-20 μ s.
- Determined by software causes:
Jitter: max. +/-30 μ s, at low speeds +/- 5 Inc.

Trigger signals are shifted by an additional factor during an acceleration or deceleration phase by comparison with the trigger point during a constant speed phase.

Example at 10000 rev/(min*s):

- Acceleration: trigger 12 μ s later
- Braking: trigger 12 μ s earlier.

trigger level

The level of the trigger signal is set by the parameter `I/O.OutTrig`. This is used to set the first trigger level after the start of list control or after list control has been interrupted.

The parameter can only be changed if no list control is active.

Group.Name	Idx:Six dec (hex)	TLHMI	Explanation and unit []	Value range	Default value	R/W per.
I/O.OutTrig	34:9 (22:9 _r)	–	Setting trigger output when signal list inactive	UINT16 0..1 0: Low level 1: High level	0	R/W-

Example of position/speed list

List-controlled operation is carried out with absolute positioning from the reference point to the 6000 Inc position. The starting speed is 100 rpm.

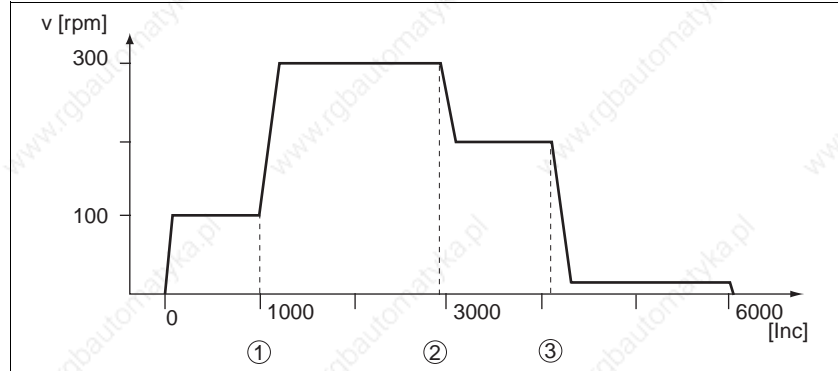

Figure 7.2 Positioning with position/speed list

- ▶ Activate position/speed list with `L2Data0.typeList2 = 2`.
- ▶ Input position values of the lists between start and end position.

Activated list excerpt for the example:

Graph point	List number 1200:x...1263:x	List type 1xxx:1	Position 1xxx:2	Trigger signal 1xxx:3	Speed 1xxx:4
1	1205	2	1000	0	300
2	1206	2	2800	0	200
3	1207	2	4200	0	10
-	0

The trigger signal column has no significance for list control with the position/speed list.

- ▶ Starting position list number 5 with `List.bgnList2 = 5` (list no.1205.x)
- ▶ End position list number 7 with `List.endList2 = 7` (list no.1207.x)
- ▶ Activate list 2 with `List.startList = 2`
- ▶ Start positioning.

The change in speed is triggered when the position from the list matches the current setpoint position.

The processing status of the list control can be monitored with the parameters `List.stateList` and Bit14: `list_quit`.

Triggering time

The controller checks whether a setpoint position at which a new speed value is triggered has been reached at intervals of 1 ms.

The trigger times must be at least 1 ms apart. Otherwise triggering of the next speed change is delayed by 1 ms.

7.2 Teach-in processing

Overview of Teach-In

Teach-in processing offers the option of recording current position values by traversing the motor and transferring them to a previously specified memory range. The size of the available memory depends on the size of the free list memory. Up to 64 position entries can be saved if a list is empty.

The data are stored in a position/signal list or a position/speed list.

Teach-in processing can be run with the following:

- TLHMI hand-held operating unit
- TLCT commissioning software
- Fieldbus
- Inputs of the signal interface (only with IO_Mode=2)

The positioning controller imports position values as absolute values in user-defined units.

Operation with TLCT or TLHMI

The commissioning software and the HMI hand-held operating unit support this operating function with special dialog boxes and menu items. For details see the manuals for the commissioning software and the TLHMI hand-held operating unit.

Starting teach-in processing

The following are required to start teach-in processing:

- Axis position defined by referencing or compensation of the encoder position during initialisation
- Power amplifier switched on and ready for operation
- Motor in positioning range
- Motor stationary
- For teach-in via the signal interface: `Settings.IO_mode = 2`.

Before teach-in processing of list positions the list type position/signal list or position/speed list must be set and list 1 or 2 selected.

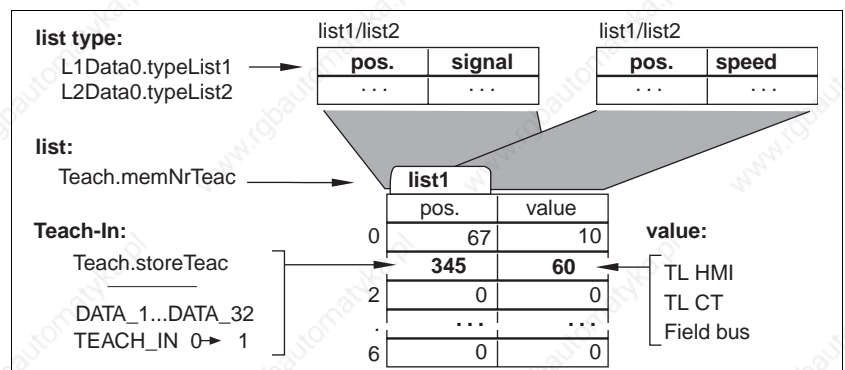

Figure 7.3 List setting

The Teach-In sequence can only be controlled via the signal interface if the parameter `Settings.IO_mode = 2` and the input signal `AUTOM = 0`.

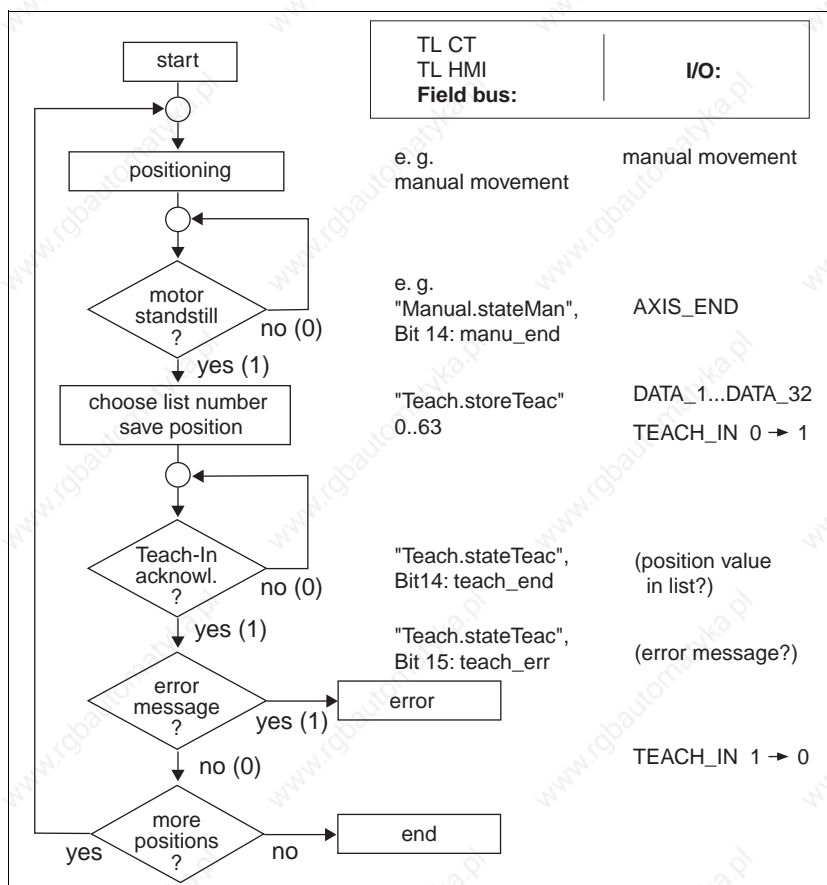

Figure 7.4 Teach-in process

After every positioning the list data can be directly changed with a connected input device.

Example for teach-in over field bus

The positioning is executed with Fieldbus commands; the selection of list, list type and list number can be set with parameters.

Group.Name	Idx:Six dec (hex)	TLHMI	Explanation and unit []	Value range	Default value	R/W per.
Teach.storeTeac	43:1 (2B:1 _h)	-	Teach-In process, select memory location list number for storing a position value (0...63) example: 000010: List number 2	UINT16 1..65535 Bit0..5: List number	0	R/W-
Teach.stateTeac	43:2 (2B:2 _h)	-	Acknowledgement: Teach-in processing	UINT16 1..65535 Bit15: teach_err Bit14: teach_end	-	R/- -
Teach.memNrTeac	43:3 (2B:3 _h)	-	Data storage for teach-in processing	UINT16 1..2 1: list data list 1 2: List data list 2	1	R/W-
Teach.p_actTeac	43:4 (2B:4 _h)	-	Motor position stored during teach-in processing [usr]	INT32 -2147483648..2147483647	-	R/- -

Group.Name	Idx:Six dec (hex)	TLHMI	Explanation and unit []	Value range	Default value	R/W per.
L1Data0.typeList1	1100:1 (44C:1 _h)	7.3.1.1	List 1: list type for ALL following list entries (1101:x...1163:x)	UINT16 1..2 1: Pos./signal 2: Pos./speed	1	R/W per.
L2Data0.typeList2	1200:1 (4B0:1 _h)	7.4.1.1	List 2: list type for all following list entries (1201:x...1263:x)	UINT16 1..2 1: Pos./signal 2: Pos./speed	1	R/W per.

Example for teach-in over signal interface

For example, the motor is positioned with the manual movement signals. List and list type must be set with parameters or an operating unit.

Before saving the position the list number must be set via the DATA_1 to DATA_32 inputs.

I/O signal	Function	Value
DATA_1	Selection of a list data set, bit-coded	0 / open
DATA_2	Examples:	
DATA_4	list no. 5 = 000101: DATA_4=1, DATA_1=1	
DATA_8	list no. 34 = 100010: DATA_32=1, DATA_2=1	
DATA_16	Non-specified inputs are zero	
DATA_32		

7.3 Calibration

Overview Calibration translates user-defined units into internal controller units and vice versa. The controller saves values for position, speed and acceleration in user-defined units. The controller calculates every value with its own standardisation factor.

This makes it unnecessary to recalculate and re-enter position or speed values if the motor is changed and the new motor has a different resolution.

The calibration of the motor position encoder cannot be changed by the user.

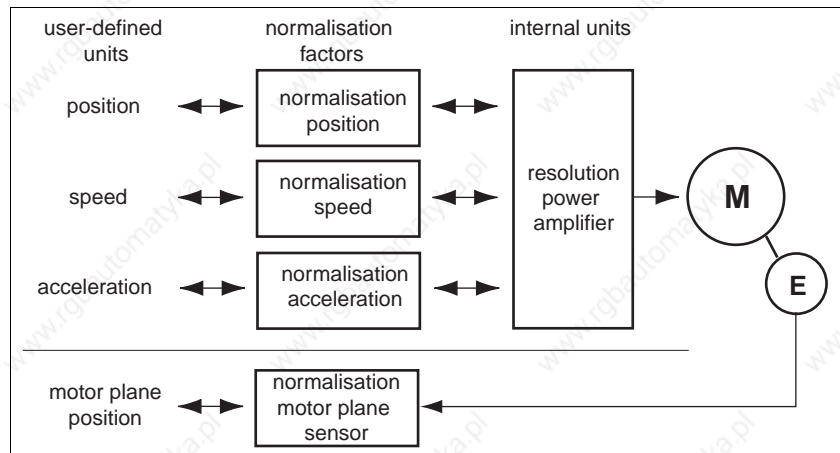

Figure 7.5 Calibration

7.3.1 Calibration factor

The calibration factor is described by the ratio of 'controller value' to 'user value'.

$$\text{Calibration factor} = \frac{\text{Controller value}}{\text{User value}}$$

Figure 7.6 The calibration factor

The units for calibration factor and 'controller value' depend on the type of calibration. The 'user value' must be given in user units [usr] for all calibration factors.

Calibration factor	User value	Controller value
Position calibration [rev/usr]	Position [usr]	Motor revolution [U]
Speed calibration [rev/(min*usr)]	Speed [usr]	Motor speed [rpm]
Acceleration calibration [rev./(min*s*usr)]	Acceleration/deceleration [usr]	Motor acceleration [rev/(min*s)]

Calibration factors are set with parameters. A new factor is activated when the numerator value is transferred.

When entering calibration factors note that the ratio can be shown as a complete mathematical fraction.

When the standardisation factors are input with the commissioning software of the hand-held operating unit, the input field for the denominator value is automatically displayed when the counter input is called.

The values of the calibration factor can only be changed when the power amplifier is inactive. Values entered in user units are converted into internal controller values when the power amplifier is activated. The range of values is checked at the same time.

Group.Name	Idx:Six dec (hex)	TLHMI	Explanation and unit []	Value range	Default value	R/W per.
Motion.pNormNum	29:7 (1D:7 _h)	4.4.20	Position calibration numerator	INT32 -2147483648 ..2147483647	1	R/W per.
Motion.pNormDen	29:8 (1D:8 _h)	–	Position calibration denominator	INT32 -2147483648 ..2147483647	16384	R/W per.
Motion.vNormNum	29:9 (1D:9 _h)	4.4.21	Speed calibration numerator	INT32 1 ..2147483647	1	R/W per.
Motion.vNormDen	29:10 (1D:A _h)	–	Speed calibration denominator	INT32 1 ..2147483647	1	R/W per.
Motion.aNormNum	29:11 (1D:B _h)	4.4.22	Acceleration calibration numerator	INT32 1..2147483647	1	R/W per.
Motion.aNormDen	29:12 (1D:C _h)	–	Acceleration calibration denominator	INT32 1..2147483647	1	R/W per.



WARNING!

Unexpected motion may cause injury and damage to the system

Changing the standardisation changes the effect of the values in user-defined units. The same movement jobs can therefore cause different motions.

- Note that the standardisation affects all relationships between the defaults and the drive motion.
- Check the corresponding usr parameters and defaults of the system in user-defined units.

7.3.2 Setting calibration factors

Calibration factor, positioning The positioning calibration factor sets the relationship of the number of motor revolutions required for a desired number of user-defined units. It is described as the ratio of 'controller value' to 'user value' and is given in rev/usr.

$$\text{normalisation factor for positioning} = \frac{\text{revolutions [rev]}}{\text{user-defined unit [usr]}}$$

Figure 7.7 Calibration factor for positioning

The minimum user resolution is the value at which a change of 1 usr effects a change in the motor position - depending on the motor type.

Motor type	Motor resolution	min. user resolution
Servomotor with resolver	4096 Inc/rev.	1/4096
Servomotor with SinCorder or SinCos	16384 Inc/rev.	1/16384

The following observations refer to a motor resolution of 1 motor revolution = 16384Inc.

Three situations can be distinguished when setting user-defined units:

- User-defined resolution corresponds to the motor resolution, e.g. 1 motor revolution = 16384 user-defined units
Any motor position can be approached.
- User-defined resolution is finer than motor resolution, e.g. 1 motor revolution = 16384 increments
1 revolution = 32768 user-defined units
Motor will move only if user-defined units change by two.
- User-defined resolution is lower than motor resolution, e.g. 1 motor revolution = 16384 increments
1 revolution = 4096 user-defined units
Every fourth motor position can be approached.



To retain the same positioning movement of the motor after changing the position standardisation factor, the following permanent parameters must be adapted in addition to the user-defined values of the application: For manual movement: 'Manual.dist_Man' and 'Manual.step_Man', for referencing 'Home.p_disHome' and 'Home.p_outHome'.

For example, if the reference parameters are not adjusted, an error may occur during the reference movement. The safety distance may not be sufficient for leaving the switching range of the limit or reference switches.



If an existing controller is replaced by this controller and the same positioning jobs as before will be used, the calibration must be set to correspond to the former controller.

Example 1

Control of an older stepper motor unit at 1000 inc/rev, i.e. a positioning at 1000 usr should correspond to one motor revolution.

User value = 1000 usr
 Controller value = 1 rev

$$\text{Position calibration} = \frac{1 \text{ rev}}{1000 \text{ usr}}$$

Example 2

Positioning of 1111 user-defined units is to correspond to 3 motor revolutions. This gives:

User value = 1111 usr
 Controller value = 3 rev

$$\text{Position calibration} = \frac{3 \text{ rev}}{1111 \text{ usr}}$$

If you carry out a relative positioning operation of 900 user-defined units now, the motor will move $900 \text{ usr} * 3/1111 \text{ rev/usr} = 2.4302 \text{ revolutions}$.

Example 3

Calculation of a calibration factor for positioning in units of length: 1 motor revolution corresponds to a path of 100 mm. Every user-defined unit [usr] should correspond to one 0.01 mm step.

This gives: $1 \text{ usr} = 0.01 \text{ mm} * 1 \text{ rev}/100 \text{ mm} = 1/10000 \text{ rev}$.

$$\text{Position calibration} = \frac{1 \text{ rev}}{10000 \text{ usr}}$$

Example 4

Setting the positioning in 1/1000 rad

$1 \text{ rad} = 1 \text{ rev}/(2 * \pi)$
 $\pi = 3.1416 \text{ (rounded)}$

User value = 1 usr
 Controller value = $1/(2 * \pi * 1000) \text{ rev}$

$$\text{Position calibration} = \frac{1 \text{ rev}}{2 * 3,1416 * 1000 \text{ usr}} = \frac{1 \text{ rev}}{6283,2 \text{ usr}} = \frac{10 \text{ rev}}{62832 \text{ usr}}$$

Calibration factor, Speed The speed calibration factor describes the relation between the number of motor revolutions and the time required for them.

It is described as the ratio of 'controller value' to 'user value' and given in rpm per usr.

$$\text{calibration factor for speed} = \frac{\text{revolutions [rev]}}{\text{unit of time [min]}} * \frac{1}{\text{user-defined unit [usr]}}$$

Figure 7.8 Calibration factor for speed

The minimum user resolution is the value at which a change of 1 usr effects a change in the motor speed.

Motor type	Motor resolution	min. user resolution
Servomotor with resolver	4096 Inc/rev.	1 / 17.48
Servomotor with Sincoder or SinCos	16384 Inc/rev.	1 / 69.91

Example 1 Setting corresponding to stepper motor resolution of 1000 Inc/rev. The speed resolution should be 1 Hz or 1/1000 rev/s.

User value = 1 usr
Controller value = 60/1000 rpm

$$\text{Speed calibration} = \frac{60 \text{ rev}}{1000 \text{ min} * 1 \text{ usr}} = \frac{3 \text{ rev}}{50 \text{ min} * \text{usr}}$$

Example 2 Setting the speed in steps of 1/10 rpm:

User value = 10 usr
Controller value = 1 rpm

$$\text{Speed calibration} = \frac{1 \text{ rev}}{1 \text{ min} * 10 \text{ usr}} = \frac{1 \text{ rev}}{10 \text{ min} * \text{usr}}$$

Example 3 Linear axis moves by 100 mm in one motor revolution; values should be entered in steps of 1 mm/s.

This gives: 1 usr = 0.01 rev/s = 60/100 rpm
User value = 1 usr
Controller value = 60/100 rpm

$$\text{Speed calibration} = \frac{60 \text{ rev}}{100 \text{ min} * 1 \text{ usr}} = \frac{3 \text{ rev}}{5 \text{ min} * \text{usr}}$$

Example 4 Setting the speed in 1/10 rad/s
 1rad = 1 rev/(2*pi)
 pi = 3.14 (rounded)
 User value = 1 usr
 Controller value = 60/(2*pi*10) rpm

$$\text{Speed calibration} = \frac{60 \text{ rev}}{100 \text{ min} * 1 \text{ usr}} = \frac{600 \text{ rev}}{628 \text{ min} * \text{usr}} = \frac{150 \text{ rev}}{157 \text{ min} * \text{usr}}$$

Calibration factor, Acceleration

The acceleration calibration factor is used to define the smallest unit for the acceleration setting

The calibration factor for acceleration is described by the ratio "controller value" to "user value" and given in rev/(min*s) per usr.

$$\text{calibration factor for acceleration} = \frac{\text{speed [rpm]}}{\text{unit of time [s]}}$$

Figure 7.9 Calibration factor for acceleration

The minimum user resolution is the value at which a change of 1 usr effects a change in the motor acceleration - depending on the motor type.

Motor type	Motor resolution	min. user resolution
Servomotor with resolver	4096 Inc/rev.	57.22 / 1
Servomotor with SinCorder or SinCos	16384 Inc/rev.	14.31 / 1

Example 1 Setting corresponding to stepper motor resolution of 1000 Inc/rev. The acceleration resolution should be 1 Hz/ms, corresponding to 1/1000 rev/(s*ms) or 60 rev/(min*s):
 User value = 1 usr
 Controller value = 60 rev/(min*s)

$$\text{Speed calibration} = \frac{60 \text{ rev}}{1 \text{ min} * \text{s} * 1 \text{ usr}} = \frac{60 \text{ rev}}{1 \text{ min} * \text{s} * \text{usr}}$$

Example 2 Setting acceleration in steps of 10 rev/(min*s):
 User value = 1 usr
 Controller value = 10 rev/(min*s)

$$\text{Speed calibration} = \frac{10 \text{ rev}}{1 \text{ min} * \text{s} * 1 \text{ usr}} = \frac{10 \text{ rev}}{1 \text{ min} * \text{s} * \text{usr}}$$

Example 3 Linear axis moves 100 mm at one motor revolution; values should be entered in steps of 10 mm/s².

User value = 1 usr

Controller value = 0.1 rev/s² = 60/10 rev/(min*s)

Acceleration calibration	=	$\frac{60 \text{ rev}}{10 \text{ min*s} * 1 \text{ usr}}$	=	$\frac{6 \text{ rev}}{1 \text{ min*s*usr}}$
--------------------------	---	---	---	---

Example 4 Setting in rad/s², 1 rad = 1 rev/(2*pi)
 1 user-defined unit = 1 rad/s² = 1 rev/(2*pi *s²) = 60/(2*pi) rev/(min*s),
 pi = 3.14 (rounded)

User value = 1 usr

Controller value = 60/(2*pi) rev/(min*s)

Acceleration calibration	=	$\frac{60 \text{ rev}}{2*3,14 \text{ min*s} * 1 \text{ usr}}$	=	$\frac{6000 \text{ rev}}{628 \text{ min*s*usr}}$	=	$\frac{1500 \text{ rev}}{157 \text{ min*s*usr}}$
--------------------------	---	---	---	--	---	--

7.3.3 Residual value in user-defined calibration

With the exception of electronic gear mode, movement data are given in user-defined units in all operating modes. Internally the controller calculates with the resolution of the motor, with AC servomotors with SinCos e.g. with 16384 Inc, and traverses to the nearest internal position corresponding to the user-defined position.

Discrepancies can occur between the actual position of the motor and the nearest possible user-defined position due to an interruption to the movement or a change from an operating mode with internal resolution to one with user-defined resolution. The differential value can be read with the parameter `Status.p_remaind`.

Group.Name	Idx:Six dec (hex)	TLHMI	Explanation and unit []	Value range	Default value	R/W per.
Status.p_remaind	31:37 (1F:25 _h)	–	Residual value of position calibration of position setpoint p_ref [Inc]	INT32 -2147483648..2147483647	–	R/- -

While using teach-in the residual value = 0 is used to display that the current motor position can be calculated exactly from the saved user-defined position. If the residual value is not equal to zero, the closest user position is stored.

Example of residual value Motor resolution is 16384 Inc/rev.

Resolution of user-defined unit [usr]: 1024 Inc/rev => 1 usr = 16 Inc.

The motor reacts to a change of one user-defined position by rotating 16 increments.

If the drive remains stationary at 16005 Inc after a movement interruption, `Status.p_remaind` shows the value 5 as the distance to the next user-defined unit.

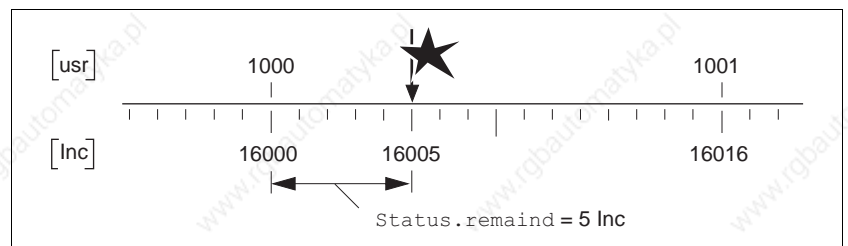

Figure 7.10 Residual value after interruption to movement at 16005 Inc

7.4 Ramp function

The controller controls the acceleration and deceleration behaviour of the motor with ramp functions. The gradient and shape of the ramp describe the ramp function. The ramp gradient shows the motor's change of speed, and the shape of the ramp shows the acceleration over time.

Ramp gradient

The slope of the acceleration and deceleration ramp can be set in the controller with the parameters `Motion.acc` and `Motion.dec`.

The controller absorbs excess braking energy during a deceleration. If the DC bus voltage increases above a permissible limit value during this process, the controller switches the power amplifier off and displays error 5 "PA overvoltage". The motor then runs down under no braking.

The slope of the deceleration ramp should be set so the motor brakes as fast as possible without switching the power amplifier because of overvoltage. The limit value is the current limiting by `CtrlBlock1.I_max` or `CtrlBlock1.I_max`.

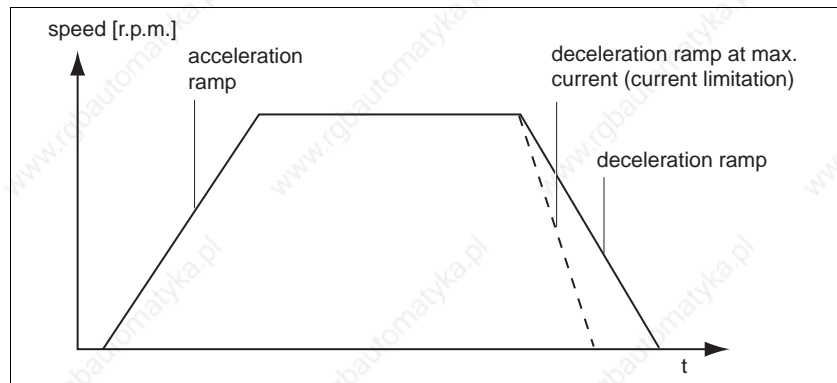

Figure 7.11 Acceleration and deceleration ramps

Settings for the ramp gradient are given in user-defined units.

Ramp shape

The controller has a linear ramp for the acceleration and deceleration phase as the ramp shape.

Group.Name	Idx:Six dec (hex)	TLHMI	Explanation and unit []	Value range	Default value	R/W per.
Motion.acc_type	29:25 (1D:19 _h)	4.4.13	Shape of acceleration curve	UINT16 1..2 1: Linear 2: -	1	R/W per
Motion.acc	29:26 (1D:1A _h)	4.4.14	Acceleration [usr]	UINT32 1.. 2 147 483 647	600	R/W per.
Motion.dec	29:27 (1D:1B _h)	4.4.15	Deceleration [usr]	UINT32 1.. 2 147 483 647	600	R/W per.

Jerk filter The jerk filter smooths out sudden speed changes so the speed changes smoothly without jerking.

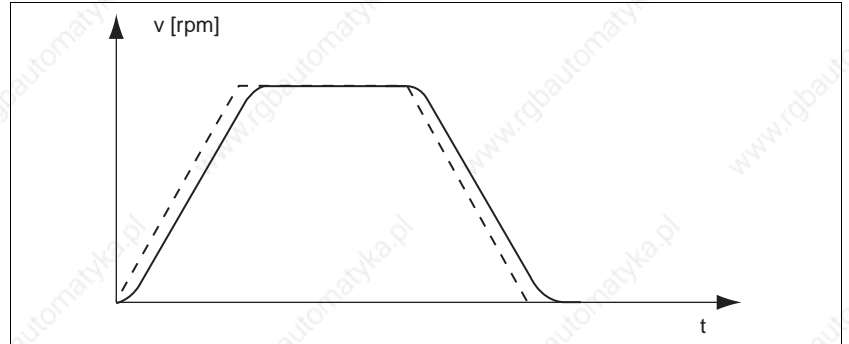

Figure 7.12 Acceleration ramp with and without (dotted line) jerk filter

The jerk filter can be disabled with the parameter `Motion.Flt_jerk`. The jerk filter is switched off when braking is carried out in Quick Stop mode.

Group.Name	Idx:Six dec (hex)	TLHMI	Explanation and unit []	Value range	Default value	R/W per.
Motion.Flt_jerk	28:5 (1C:5 _h)	4.4.26	Jerk filter	UINT16 0..30 0: from 3..30: filter setting value	0	R/W per.

7.5 Quick-Stop function



WARNING!

Danger of injury and damage to system components by unbraked motor.

An insufficient ballast resistance causes overvoltage at the DC bus and switches off the power amplifier. The motor is no longer actively braked.

- Make sure that the ballast resistor is sufficiently dimensioned.
- Check the setting of the parameter for the ballast.
- Check the temperature of the ballast resistor by conducting a test run under the most critical conditions.
- During the test make sure that at higher line voltage there is less reserve in the capacitors on the DC bus.

Quick-Stop is a fast-braking function, which stops the motor, e.g. if a fault occurs.

Quick-Stop can be triggered by

- tripping a software limit switch range SW_LIMP or SW_LIMN
- by an operating fault that makes a fast braking procedure necessary
- the input signal \overline{STOP}
- the stop command over a connected input device
- limit switch or reference switch

In the event of a fault category 1 fault response, the power amplifier remains on.

Group.Name	Idx:Six dec (hex)	TLHMI	Explanation and unit []	Value range	Default value	R/W per.
Settings.SignQstop	28:20 (1C:14 _h)	4.1.26	Control signals that trigger a Quick-Stop via 0: deceleration ramp 1: Quick-Stop ramp	UINT16 Bit0: LIMP Bit1: LIMN Bit2: STOP Bit3: REF Bit4..6: - Bit7: SW_STOP	0	R/W per.

Depending on the operating mode the parameter `Settings.SignQStop` can be used to select the type of brake function.

	Electronic gear current control	manual movement speed mode point-to-point mode referencing oscillator mode
Settings.SignQStop = 0	Torque ramp with <code>CtrlBlock1.I_max</code> or <code>CtrlBlock2.I_max</code>	Deceleration ramp with <code>Motion.Dec</code>
Settings.SignQStop = 1	Torque ramp with <code>Settings.I_maxStop</code>	Torque ramp with <code>Settings.I_maxStop</code>

Maximum current for Quick-Stop

The controller absorbs excess braking energy during a Quick-Stop. If the DC bus voltage increases above a permissible limit value during this process, the controller switches the power amplifier off and displays error 5 "Overvoltage". The motor then runs down under no braking.

The current for the deceleration torque should be set so the controller comes to a stop with maximum deceleration without switching off.

Group.Name	Idx:Six dec (hex)	TLHMI	Explanation and unit []	Value range	Default value	R/W per.
Set- tings.l_maxSTOP	28:22 (1C:16 _h)	4.1.3	Current limit for quick stop (100=1A _{pk})	UINT16 0..max. Current 0..29999	1000	R/W per.

Acknowledging Quick-Stop

If the controller switches off frequently during a Quick-Stop with error 5 "overvoltage", the maximum braking current must be reduced, the drive load reduced or an external ballast resistor fitted.

Quick-Stop must be acknowledged via the input signal `FAULT_RESET` or the error confirmation of an input device.

I/O signal	Function	Value
<code>FAULT_RESET</code>	Resetting an error message	0 -> 1

If the motor is stopped by `stop` the $\overline{\text{STOP}}$ signal must be reset first.

If Quick-Stop was triggered by the limit switch signals $\overline{\text{LIMN}}$ or $\overline{\text{LIMP}}$, the drive must be traversed back to the movement range in manual mode, see page 7-33.

7.6 StopMotion

Availability This function is available in controllers from software version 1.205.

Function The user can interrupt a running movement with StopMotion. Interruption of the motion is not considered an error, i.e. there is no error response in contrast to e.g. an interruption via "Stop (QuickStop)" in the control word `Commands.driveCtrl`.

The following requirements identify the special process:

- It is controlled via bit 5=1 in the control word `Commands.driveCtrl`
- There is no error entry in the error memory
- The status remains at "Operation Enable"
- The standstill is reported in `Status.driveStat` via bit14:`x_end` is equal to 1. The response received is the same as that for a normal movement end.
Via Bit13 (`x_add_info`: "setpoint position reached") in `Status.driveStat` can (for example) be detected in PTP mode whether the setpoint position of the profile generator has been reached or not. The response in the various operating modes can be found in the table below.
- The deceleration always runs via the normal ramp (TLCx1x) or the torque ramp (TLCx3x) using the setting of the "default current" in `CtrlBlock1.I_max` or `CtrlBlock2.I_max`.
- The axis mode is retained.
- A new operating mode can only be enabled after standstill.

After interruption of a manual or reference movement with StopMotion the operating mode cannot be continued from a random interruption point. The processing of the movement sequence can only be restarted from scratch.

7.6.1 Control word for state change

Group.Name	Idx:Six dec (hex)	TLHMI	Explanation and unit []	Value range	Default value	R/W per.
<code>Commands.driveCtrl</code>	28:1 (1C:1h)	-	Control word for status change Write access triggers processing of the status machine	UINT16 0...15 Bit 0: Disable power amplifier Bit 1: Enable power amplifier Bit 2: Stop (QuickStop) Bit 3: FaultReset Bit 4: QuickstopRelease (TLC units only, internal accesses only) Bit 5: StopMotion (TLC units only) Bit 6...15: not assigned	0	R/W -

7.6.2 Reactions on movement interruption by StopMotion

The information in the table below applies for achieved standstill.

Operating mode	x_add_info	Comments
Manual movement ¹⁾	-	
Speed mode	0	
PTP	0	Special case: if the movement interruption only occurs in the normal deceleration phase, "setpoint position reached" is set on drive standstill.
Electric gear ¹⁾	-	On offset positioning the bit "Offset setpoint position reached" is not set.
Referencing ¹⁾	-	Identifier "ref_ok" is not set
Oscillator mode	0	
Current control	1	curr_ctrl_nact_zero indicates that the drive is at standstill/ corresponds to the response on processing without "StopMotion".

1) In these operating modes x_add_info has no meaning, 0 is always output as value.

7.7 Standstill window

If the motor remains in the standstill window for the period of time defined in `Settings.p_winTime`, the controller reports that the motor is at standstill.

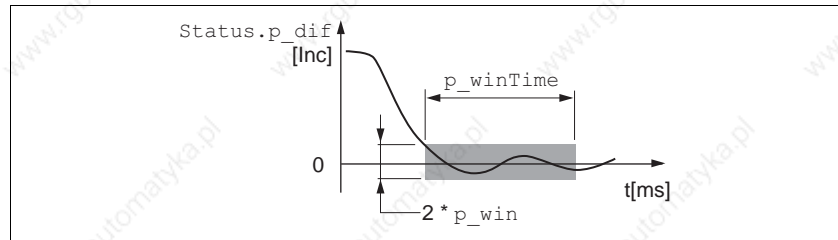

Figure 7.13 Standstill window

The parameters `Settings.p_win` and `Settings.p_winTime` define the size of the window.

The parameter `Settings.p_winTout` can be used to set the period after which an error is reported if the standstill window was not reached.

Group.Name	Idx:Six dec (hex)	TLHMI	Explanation and unit []	Value range	Default value	R/W per.
Settings.p_win	12:13 (C:D _h)	4.1.24	Standstill window, permissible control deviation [Inc]	UINT16 0..32767	16	R/W per.
Settings.p_winTime	12:15 (C:F _h)	4.1.25	Time for which the control deviations must remain in the standstill window for standstill to be reported [ms] 0: Standstill monitoring switched off	UINT16 0..32767	0	R/W per.
Settings.p_winTout	12:21 (C:15 _h)	4.1.27	Time within which the standstill must be reported [ms] 0: disabled	UINT16 0 .. 32767	0	R/W per.

Group.Name	Idx:Six dec (hex)	TLHMI	Explanation and unit []	Value range	Default value	R/W per.
Status.xMode_act	28:3 (1C:3 _h)	2.3.5.5	Current axis mode with additional information, Bit0..4: For a list of possible operating modes for your TL unit see Chapter 'Operating modes'	UINT16 0..65535 Bit0..4: Current operating mode (device-specific) [For a list of possible operating modes for your TL device see Chapter "Operating modes"] 0: not used 1: manual positioning mode 2: referencing 3: PTP positioning 4: speed profile 5: electronic gear with offset adjustment, position-controlled (AC) or with position reference (SM) 6: electronic gear speed-controlled 7: data set mode 8: function generator (current controller) 9: function generator (speed controller) 10: function generator (position controller) 11..15: cannot be set 16: function generator in status disabled 17: current regulation 18: oscillator mode 19..30: reserved 31: do not use Bit5: drive is referenced ('ref_OK') Bit6: control deviation inside position window (SM: not assigned) Bit7: reserved Bit8..15: not assigned	–	R/- -

7.8 Reversal of direction of rotation

The parameter `Motion.invertDir` can be used to reverse the direction of rotation of the motor.

The limit switch that limits the working range with positive direction of rotation must be connected to `LIMP`. The limit switch that limits the working range with negative direction of rotation must be connected to `LIMN`.

Group.Name	Idx:Six dec (hex)	TLHMI	Explanation and unit []	Value range	Default value	R/W per.
Motion.invertDir	28:6 (1C:6h)	4.4.27	Inversion of sense of rotation	UINT16 0..2 0: no inversion 1: direction inversion function Mode1: after controller startup the current encoder value is inverted 2: direction inversion function Mode2: after controller startup the current encoder value is not inverted (only motors with Multiturn rotary encoder)	0	R/W per.

If the direction of rotation of the motor must be reversed, all parameter values can be imported unchanged except for the parameters for position processing with SinCos Multiturn.

When the direction of rotation is reversed, the absolute position of the motor `Status.p_absall`, which is read from the rotary encoder, is changed and the actual position `Status.p_act` calculated by the Twin Line unit.

Therefore, the direction of rotation must be set during commissioning as it will be used during later operation of this motor.

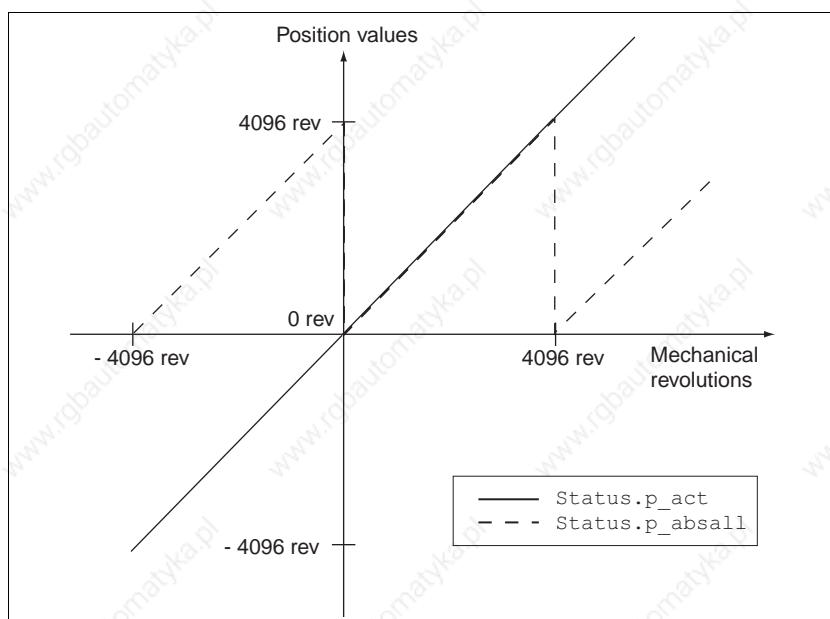

Figure 7.14 Position values `p_act` and `p_absall` without direction reversal

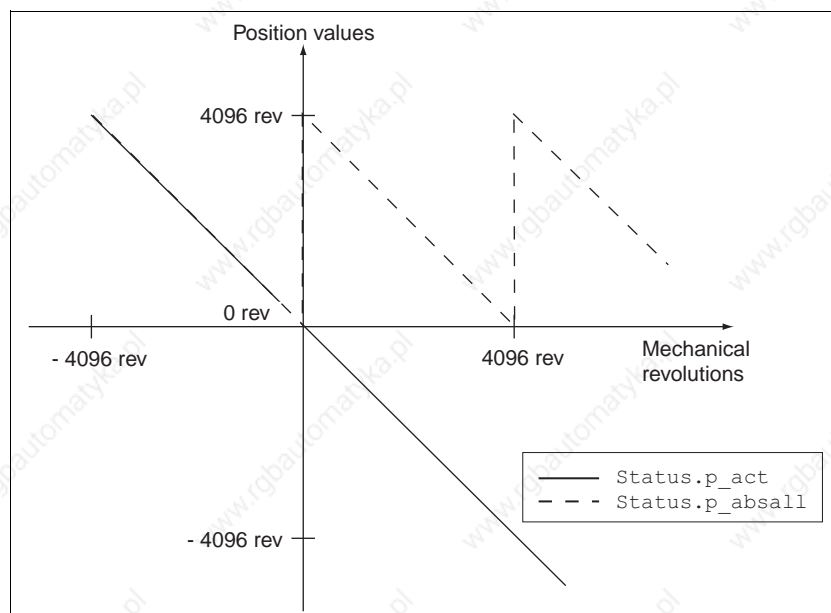

Figure 7.15 Position values p_{act} and p_{absall} with direction reversal

To prevent further unsteady positions in the traverse range after switching on and off, $M2$. `SetEncPos` must be reset. See 5.4.7 „Setting device parameters for rotary encoder“ page 5-21.

7.9 Fast position capture

Position values can be recorded via two channels whose parameters can be adjusted. The capture inputs have an input delay time of 100 μ s. The delay period scatter is max. +/-10 μ s. At constant drive speed the jitter is maximum +/-5 μ s.

The parameter `Capture.TrigSign` specifies the signal source of a position value capture: the CAPTURE1 and CAPTURE2 inputs of the signal interface or the index pulse of a position encoder in slot M1. If M1 has nothing installed, the parameter `Capture.TrigType` is not displayed.

A capture can be triggered by a rising or falling signal slope. The slope change can be set with the parameter `Capture.TrigLevl`. Changes to the parameters `Capture.TrigType` and `Capture.TrigLevl` are only taken into account when the positioning detection is restarted by writing to the parameter `Capture.TrigStart`.

Starting position capture

The parameter `Capture.TrigStart` activates a new recording. Any stored position value is first deleted. As soon as a new position value has been saved, the signal level of the parameter `Capture.TrigStat` switches from "0" to "1". The value remains stored until a new process is triggered for this channel.

Either the actual position of the motor or the numerator value of the guidance sensor are used as the position, the controller calculates the other value and registers it. The position values are read with `Capture.TrigPact1/2` and `Capture.TrigPref1/2`.

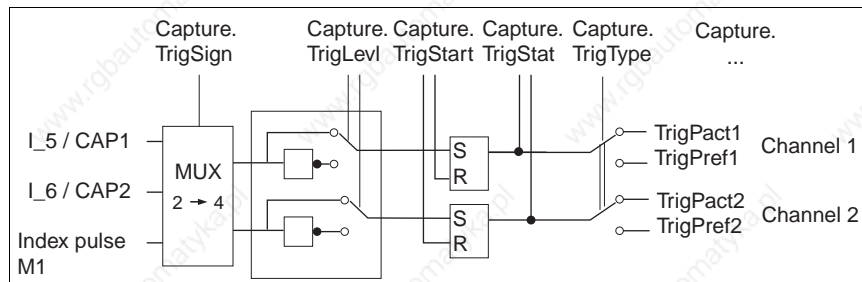

Figure 7.16 Fast position capture, signal pattern and parameter

Continuous position capture

The position capture can be run once or continuously; it can be set with Bit 15 in `Capture.TrigStart`:

- Bit 15=0: The position value after the first triggering is stored. Further values are ignored until the process is restarted.
- Bit 15=1: Every triggering updates the position value.

Group.Name	Idx:Six dec (hex)	TLHMI	Explanation and unit []	Value range	Default value	R/W per.
Capture.TrigSign	20:13 (14:D _h)	–	Selection of trigger signals for saving the position Bit 3..2: signal - channel 2 (K2) Bit 1..0: signal - channel 1 (K1) examples: 4: binary 01 00 => CAPTURE2 (K2), CAPTURE1 (K1) 9: 10 01 => CAPTURE2 (K2), index p. setpoint pos. (K1)	UINT16 0..15 Bit 0..1/ Bit 2..3 (K1/K2): - 00: CAPTURE1 - 01: CAPTURE2 - 10: index pulse setpoint pos. sensor (with module at M1) - 11: index pulse actual pos. sensor (in SM with module at M2)	4	R/W-
Capture.TrigType	20:14 (14:E _h)	–	Position source for saving the position	UINT16 0..1 0: actual position encoder 1: setpoint position encoder	1	R/W-
Capture.TrigLevl	20:15 (14:F _h)	–	Signal level for trigger channels Bit status: 0: triggering at 1->0 switch 1: triggering at 0->1 switch	UINT16 0..3 Bit 0: set trigger level at channel 1 Bit 1: set trigger level on channel 2	3	R/W-
Capture.TrigStart	20:16 (14:10 _h)	–	start triggering (bits0..1): 0: no change 1: reset triggers and restart interrupt triggers (Bit14=1) repeat triggers (Bit15) 0: trigger once 1: trigger continuously	UINT16 0..3 Bit 0: trigger at channel 1 Bit 1: trigger at channel 2 Bit 14: interrupt trigger Bit 15: Trig. repeat	0	R/W-
Capture.TrigStat	20:17 (14:11 _h)	–	Status, triggering executed	UINT16 0..3 Bit 0: triggering at channel 1 Bit 1: triggering on channel 2	0	R/- -
Capture.TrigPact1	20:18 (14:12 _h)	–	Actual position of motor on triggering on channel 1 [Inc]	INT32 -214748364..2147483647	–	R/- -
Capture.TrigPact2	20:19 (14:13 _h)	–	Actual position of motor on triggering on channel 2 [Inc]	INT32 -214748364..2147483647	–	R/- -
Capture.TrigPref1	20:20 (14:14 _h)	–	Setpoint of elect. gear on triggering on channel 1 [Inc]	INT32 -214748364..2147483647	–	R/- -
Capture.TrigPref2	20:21 (14:15 _h)	–	Setpoint of elect. gear on triggering on channel 2 [Inc]	INT32 -214748364..2147483647	–	R/- -

7.10 Monitoring functions

7.10.1 Monitoring of axis signals

Positioning limits The motor can be moved to any point on the axis within the axis positioning range by specifying an absolute positioning process.

The axis travel range is specified in internal units in the range -2^{31} to $+2^{31}$ increments. The resolution of the motor encoder in increments is specified as the internal unit. The current position can be read with the parameter `Status.p_act`

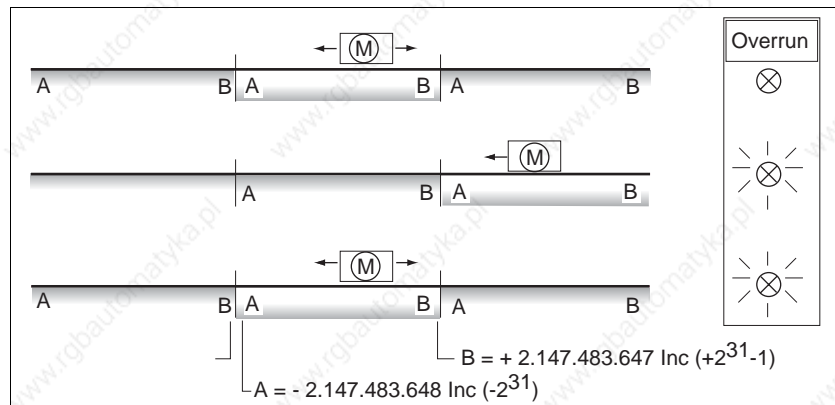

Figure 7.17 Positioning range and range overrun

If the motor crosses the positioning limits, the internal monitoring signal for position overrun is set and the work area moved by 2^{32} units. The parameter `Status.IntSigSR (29.34)` shows a position overrun with Bit 2. In addition, the error code "E181A" is registered in the error memory of the controller.

The monitoring signal remains set when the motor moves back into the valid area. The signal is reset by renewed referencing or by switching the controller off and on.

The positioning limits can be tripped in all operating modes, except for PTP absolute positioning. In the case of PTP relative positioning there is an implicit dimension setting to 0 before tripping the limit. In addition, the error code "E181A" is registered in the error memory of the controller. The reference identifier is deleted with the parameter `Status.xMode_act (28:3) Bit 5`.

Teach-in processing is not possible after overshooting the range limits, because the positions are no longer defined. Overshoot of the range limits can be prevented by enabling software limit switches.

Group.Name	Idx:Six dec (hex)	TLHMI	Explanation and unit []	Value range	Default value	R/W per.
Status.IntSigSr	29:34 (1D:22 _h)	2.3.4.2	Monitoring signals controller 0: not enabled, 1: enabled	UINT32 0..4294967295 Bit0..1: reserved Bit2: position overrun Bit3..4: reserved Bit5: SW limit switch, pos. direction of rotation (SW_LIMP) Bit 6: SW limit switch, neg. direction of rotation (SW_LIMN) Bit7: stop via control word (SWSTOP) Bit8..14: reserved Bit15: power amplifier not active Bit16..31: reserved	–	R/- -

Software limit switches The software limit switch position is set with the parameters `Motion.SW_LimP` and `Motion.SW_LimN` and activated with `Motion.SW_Enabl`. The determining factor for position monitoring of the software limit switch range is the setpoint of the position controller. Depending on the controller setting, therefore, the motor can stop before it reaches the limit switch position. Bits 5 and 6 of the parameter `Status.IntSigSr` report the tripping of the limit switch position.

Group.Name	Idx:Six dec (hex)	TLHMI	Explanation and unit []	Value range	Default value	R/W per.
Motion.SW_LimP	29:4 (1D:4 _h)	4.4.5	Software limit switch for pos. position limit LIMP Condition: SW_LimP > SW_LimN [usr]	INT32 -2147483648 ..2147483647	2147483647	R/W per.
Motion.SW_LimN	29:5 (1D:5 _h)	4.4.6	Software limit switch for pos. position limit LIMN Condition: SW_LimN < SW_LimP [usr]	INT32 -2147483648 ..2147483647	-2147483647	R/W per.
Motion.SW_Enabl	29:6 (1D:6 _h)	4.4.7	Set monitoring of software limit switch 0: disabled 1: enabled	UINT16 0..96 Bit5: SW_LIMP Bit6: SW_LIMN	0	R/W per.
Status.IntSigSr	29:34 (1D:22 _h)	2.3.4.2	Monitoring signals controller 0: not enabled, 1: enabled	UINT32 0..4294967295 Bit0..1: reserved Bit2: position overrun Bit3..4: reserved Bit5: SW limit switch, pos. direction of rotation (SW_LIMP) Bit 6: SW limit switch, neg. direction of rotation (SW_LIMN) Bit7: stop via control word (SWSTOP) Bit8..14: reserved Bit15: power amplifier not active Bit16..31: reserved	–	R/- -

Limit switch and \overline{STOP} signal



CAUTION!

Loss of control over controller.

The use of \overline{LIMP} and \overline{LIMN} can offer some protection against dangers (e.g. impact on mechanical stop caused by incorrect motion defaults).

- Use \overline{LIMP} and \overline{LIMN} where possible.
- Check that the external sensors or switches are correctly connected.
- Check that the external sensors or switches are installed correctly for their function. The braking distance of the drive must not cause damage.
- The functions must be enabled in the controller software to allow \overline{LIMP} and \overline{LIMN} to be used.
- This function cannot provide protection against faulty functioning within the controller or the sensors.

During the movement the two limit switches are monitored with the input signals \overline{LIMN} and \overline{LIMP} . If the drive travels to a limit switch, the controller stops the motor. The triggering of the limit switch is signalled on the input device. Set up the limit switch so the drive cannot trip the limit switch.

The input signal \overline{STOP} stops the motor with Quick-Stop. Further processing is possible if:

- the STOP signal is cancelled and
- Quick-Stop has been acknowledged and
- a new movement command is activated

The release of the input signals \overline{REF} , \overline{LIMP} , \overline{LIMN} and \overline{STOP} and the evaluation to active Low or High can be changed with the parameters `Settings.SignEnabl` and `Settings.SignLevel`:

Group.Name	Idx:Six dec (hex)	TLHMI	Explanation and unit []	Value range	Default value	R/W per.
Settings.SignEnabl	28:13 (1C:D _h)	4.1.10	Signal release for monitoring inputs 0: blocked 1: enabled	UINT16 0..15 Bit 0 : LIMP Bit 1: LIMN Bit 2: STOP Bit 3: REF	7	R/W per.
Settings.SignLevel	28:14 (1C:E _h)	4.1.11	Signal level for monitoring inputs 0: response at 0 level 1: response at 1 level	UINT16 0..15 Bit 0 : LIMP Bit 1: LIMN Bit 2: STOP Bit 3: REF	0	R/W per.

The REF switch does not have to be enabled for the reference movement. If the REF switch is enabled, it takes on the function of an additional STOP switch (exception: reference movement to REF).

Moving the drive out of the limit switch area

The drive must be retracted from the limit switch area to the movement range in manual mode.

- ▶ If `Settings.IO_mode = 2`, switch to manual mode with input signal AUTOM.
- ▶ Activate and hold the manual movement signal to retract the drive to the permissible movement range: If the limit switch signal \overline{LIMP} has been triggered, the signal `MAN_N` must be enabled and vice versa.

If the drive does not move back into the travel area, check whether manual mode has been activated and the correct manual movement signal held.

7.10.2 Monitoring internal signals

Monitoring systems protect motor, power amplifier and load resistors from overheating, and ensure functional and operational safety. You will find a list of all safety devices in 2.5 „Monitoring functions“ on page 2-4

The controller displays error messages and warnings by flashing the 7-segment display. In addition a connected control panel displays an error text.

Temperature monitoring

Sensors monitor the temperature of motor, power amplifier and load resistor. If the temperature of one of the components approaches the permissible limit temperature, the controller displays a warning. If the temperature exceeds the limit value for more than five seconds, the controller switches the power amplifier and the control to prevent overheating and reports a temperature error.

If the motor is fitted with a temperature switch instead of a sensor, only the upper temperature limit can be monitored with no prior warning. All temperature limits are permanently set.

Group.Name	Idx:Six dec (hex)	TLHMI	Explanation and unit []	Value range	Default value	R/W per.
PA.T_warnPA	16:10 (10:A _n)	2.2.15	Temperature warning threshold of the current amplifier [K]	UINT16 1..512	353	R/W per.
PA.T_maxPA	16:11 (10:B _n)	2.2.16	Max. permitted temperature of the current amplifier [K]	UINT16 1..512	358	R/W per.

I²t monitoring

If the controller operates at high peak currents, temperature monitoring with sensors may be too slow. With I²t monitoring the closed-loop control anticipates a rise in temperature in time and if the I²t threshold is exceeded, it reduces the motor, amplifier or load resistor current to their rated value.

If the limit value is exceeded, the component in question can travel to the performance limit.

Group.Name	Idx:Six dec (hex)	TLHMI	Explanation and unit []	Value range	Default value	R/W per.
PA.I2tPA	16:13 (10:D _n)	2.2.10	Max. permitted time for max. current at high speed [ms]	UINT16 1..32767	3000	R/W per.

Group.Name	Idx:Six dec (hex)	TLHMI	Explanation and unit []	Value range	Default value	R/W per.
PA.I2t_warnB	16:14 (10:E _h)	2.2.12	Warning threshold for make time of internal ballast resistor [ms]	UINT16 1..32767	10	R/W per.
PA.I2tB	16:15 (10:F _h)	2.2.11	Max. permitted make time of internal ballast resistor [ms]	UINT16 1..32767	11	R/W per.
PA.I2t_n0PA	16:47 (10:2F _h)	2.2.13	Max. permitted time for max. current at low speed [ms]	UINT16 1..32767	400	R/W per.

Following error monitoring

Following error monitoring checks for positional discrepancies between the actual position of the motor and its setpoint. If the difference exceeds a following error threshold value, the controller reports an error. The threshold for the following error deviation can be set

The error class for a following error can also be changed, see also „Monitoring parameters“.

Group.Name	Idx:Six dec (hex)	TLHMI	Explanation and unit []	Value range	Default value	R/W per.
Settings.p_maxDiff	12:11 (C:B _h)	4.1.23	Maximum permitted following error of the position controller [Inc]	UINT32 0..131072 8 motor revolutions With resolver motor max. 8*4096 Inc	16384	R/W per.

Monitoring parameters

The parameters listed in the 'Status' set can be used to monitor unit status and operating status with parameters. They include

- Status.FltSig, Status.FltSig_SR and Status.IntSigSR for monitoring internal device unit signals
- Status.action_st for monitoring the operating status
- Status.StopFault, with which the last cause of interruption can be determined.

You will find information on evaluating the monitoring facilities built into the unit over the Fieldbus in 8 „Diagnostics and troubleshooting“ on page 8-1

Change error class

The response of the controller to an error is subdivided into error classes and can be set. It can be used to match the controller error response to the operating requirements.

Group.Name	Idx:Six dec (hex)	TLHMI	Explanation and unit []	Value range	Default value	R/W per.
Settings.Flt_pDiff	28:24 (1C:18 _h)	4.1.13	Error response to following error	UINT16 0..3 0: error class (warning) 1: error class 1 2: error class 2 3: error class 3	3	R/W per.

**WARNING!****Danger of injury and damage to system components by loss of control over the controller!**

If the error response is set to error class 0, when the following error limit is exceeded a Quick-Stop is not executed nor is the power amplifier switched off. The drive can also remain active with large position deviations.

- Check possible consequences of the error response selected for the system.

7.10.3 Commutation monitoring

Availability

This function is available in controllers from software version 1.205.

Functional principle

The functional principle of Twin Line servo units in position and speed-controlled mode continuously checks the plausibility of the motor acceleration and effective motor torque to detect uncontrollable motor movements and if necessary to suppress them. This monitoring function is referred to as commutation monitoring.

If the motor accelerates over a period of over 5 to 10 ms although the TL drive controller is decelerating the servo motor with the maximum specified current, the commutation monitoring detects an uncontrolled motor movement.

In this case the drive controller reacts to this error with an error response in accordance with error class 4. The 7-segment display shows a flashing "c".

Causes of error

Uncontrolled motor movements result from the following causes:

- Motor phases U, V, W have been incorrectly connected to the unit by being offset by 120°.
- Defective or faulty capture of the rotor position as a result of a defective position sensor on the motor, faulty sensor signals or defective position capture in the controller

The controller can also detect a commutation error in the following cases:

- The motor receives an external torque that is greater than the specified maximum torque. The external force causes it to accelerate.
- The motor is rotated manually against the motor torque with drive control active.
- The motor is moved to a mechanical stop.
- Speed and position control loop are set to be extremely unstable.

Setting parameters



WARNING!

Danger of injury and damage to system components by unexpected movement!

Disabling monitoring functions increases the risk of an unexpected movement.

- Use the monitoring functions.

In exceptional cases commutation monitoring can be switched off with the parameter `Setting.CommutChk = 1`. Use the commutation monitoring whenever possible.

7.10.4 Monitoring communications with Fieldbus

The following diagnostic values are available to monitor Fieldbus communications.

- Contents of transmission data of the controller
- Contents of received data of the controller
- Bus statistics for determining the frequency of communication errors.

The diagnostic values can be read as follows:

- TLHMI
- TLCT
- Fieldbus

TLCT: Displaying objects

- ▶ Open the diagnosis window with the menu item "Twin Line - Diagnosis - Device data."
- ▶ Enter index and subindex of the desired diagnostic value in the 'device data' window.

Transmission and receive data

The current contents of the transmission and received data can be determined with the following diagnosis values. See the Fieldbus manuals for the byte assignments.

Group.Name	Idx:Six dec (hex)	TLHMI	Explanation and unit []	Value range	Default value	R/W per.
M4.busTxD	24:33 (18:21 _h)	2.6.2	Transmission data online command processing (Byte 1 ... 4)	UINT32 0.. 4294967295	0	R/- -
M4.busTxD5_8	24:34 (18:22 _h)	2.6.2	Transmission data online command processing (Byte 5 ... 8)	UINT32 0.. 4294967295	0	R/- -
M4.busRxD	24:28 (18:1C _h)	2.6.1	Received data online command processing (Byte 1 ... 4)	UINT32 0.. 4294967295	0	R/- -
M4.busRxD5_8	24:29 (18:1D _h)	2.6.1	Received data online command processing (Byte 5 ... 8)	UINT32 0.. 4294967295	0	R/- -

0098 441 113 110, V1.00, 07.2004

Bus statistics The bus statistics can be used to find information on the number of timeout errors and bus cycles. The total of all errors that resulted in breaking a connection can be determined. The following diagnostic values in the M4 parameter group are available:

Group.Name	Idx:Six dec (hex)	TLHMI	Explanation and unit []	Value range	Default value	R/W per.
M4.busTout	24:31 (18:1F _h)	2.6.6	Bus statistics timeout: Total number of broken connections caused by timeout (node guarding)	UINT16 0 .. 65535	0	R/W-
M4.busError	24:32 (18:20 _h)	2.6.7	Bus statistics transmission error: total of all errors that resulted in a connection break	UINT16 0 .. 65535	0	R/W-
M4.busCycle	24:35 (18:23 _h)	2.6.6	Bus statistics bus cycles: Total number of all processed bus cycles	UINT32 0.. 4294967295	0	R/W-

7.11 Braking function with TLHBC

In motors fitted with a holding brake the brake prevents unintended movement of the motor when not under power. The holding brake is controlled by the holding brake controller, which is available as an accessory.

Holding brake controller

The holding brake controller increases the control signal `ACTIVE_CON` at the signal interface and controls the brake to make it switch quickly and generate as little heat as possible. In addition, the brake terminal, which is in the same cable as the power connections to the motor, is safely isolated from the controller signal connections in the event of insulation breaks occurring in the motor cable.

IP20 controller

The holding brake can be released with the push-button switch fitted to the holding brake controller for commissioning and function tests.

IP54 controller

For commissioning and function checking the holding brake can be controlled with the TLCT commissioning software or the TLHMI.

Braking signals

`ACTIVE_CON` switches to "high" as soon as the power amplifier is enabled and the motor has holding torque. The brake opens after a time delay required for releasing the brake. The time delay can be adjusted.

I/O signal	Function	Value
<code>ACTIVE_CON</code>	Brake will be opened or is open	high
<code>ACTIVE_CON</code>	Brake will be applied or is applied	low

The time delay can be set with the parameters `Settings.t_brk_off` and `Settings.t_brk_on`.

Releasing the holding brake

When the holding brake is released the parameter `Settings.t_brk_off` initiates a delayed drive response to the enable command.

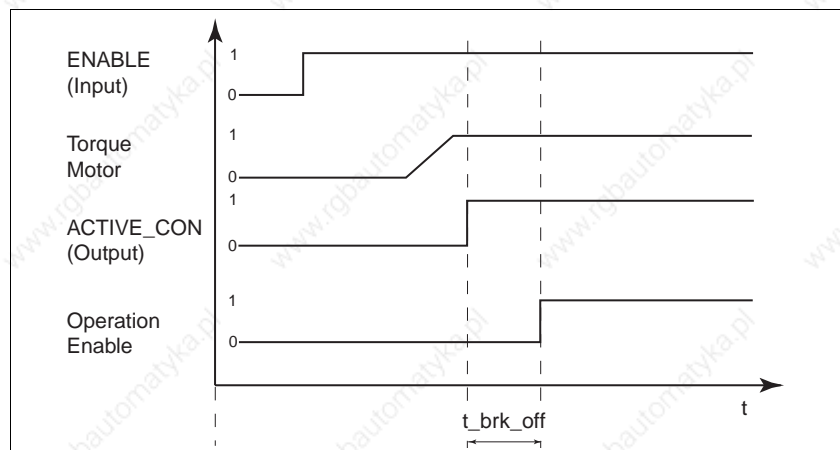

Figure 7.18 Releasing the holding brake

The setting of the parameter `Settings.t_brk_off` depends on the motor type and can be found in the motor type plate.

0098 441 113 110, V1.00, 07.2004

Group.Name	Idx:Six dec (hex)	TLHMI	Explanation and unit []	Value range	Default value	R/W per.
Settings.t_brk_off	12:22 (C:16 _h)	4.1.36	Time delay for holding brake release [ms]	UINT16 0 .. 200	0	R/W per.

Applying the brake When the brake is applied the controller switches ACTIVE_CON to "low" after a disable. However, the closed-loop control remains active for the specified time in the parameter Settings.t_brk_off.

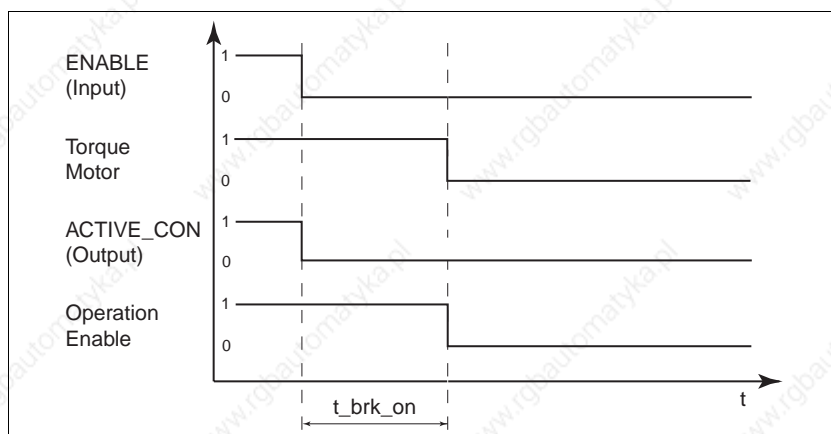

Figure 7.19 Applying the holding brake

The setting of the parameter Settings.t_brk_on depends on the motor type and can be found in the motor type plate.

Group.Name	Idx:Six dec (hex)	TLHMI	Explanation and unit []	Value range	Default value	R/W per.
Settings.t_brk_on	12:23 (C:17 _h)	4.1.37	Time delay for controller with holding brake applied [ms]	UINT16 0 .. 100	0	R/W per.

Voltage reduction

The holding brake controller switch must be set depending on the motor type to implement a voltage reduction, if required.

1: voltage reduction on, for SER... motors
0: voltage reduction off, for DSM4... motors

The control voltage from the holding brake control system is variable if the voltage reduction function is switched on. The voltage is then 24V for approx. 100 ms and afterwards falls back to its holding voltage of 12V. The holding brake controller can be checked with a button integrated in the TLHBC.

The following diagram shows the voltage reduction for `Settings.t_brk_off = 0` and `Settings.t_brk_on = 0`.

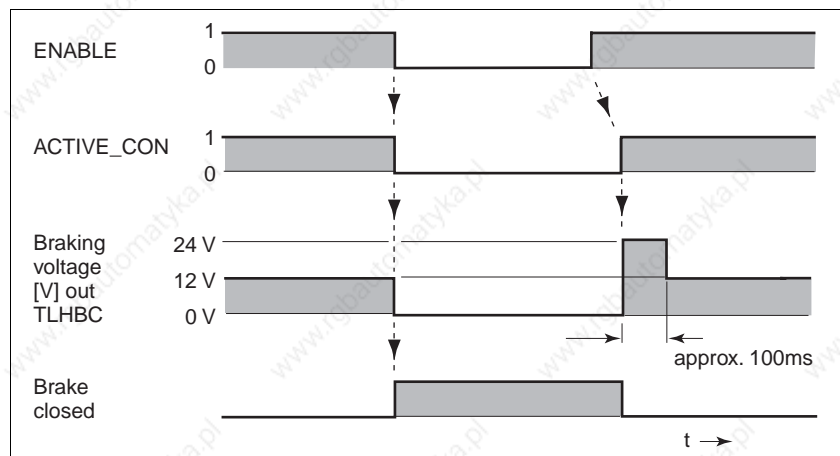

Figure 7.20 Time diagram, brake function with voltage reduction on

When the power is switched on, the holding brake control system and the button function are reset. No voltage is present on the control terminals of the brake, and the control system LED is off.

The LED flashes on overload or short circuit.

7.12 Additional analogue interfaces

A controller with an analogue module has additional functions with two analogue inputs and two analogue outputs.

Analogue inputs

Analogue input voltages between -10 V and +10 V can be read in through the analogue inputs. The current voltage value can be read with the parameters `M1.AnalogIn2` and `M1.AnalogIn3`.

Group.Name	Idx:Six dec (hex)	TLHMI	Explanation and unit []	Value range	Default value	R/W per.
M1.AnalogIn2	21:14 (15:E _h)	2.3.3.5	voltage value analogue input 2 [mV]	INT16 -10000.. +10000	–	R/- -
M1.AnalogIn3	21:19 (15:13 _h)	2.3.3.6	voltage value analogue input 3 [mV]	INT16 -10000.. +10000	–	R/- -

Analogue outputs



WARNING!

Unexpected motion may cause injury and damage to the system.

When the controller starts (after switching on the +24VDC or power failure), the analogue output of the IOM-C module is at +10V. If the output is connected with a downstream drive, the downstream drive may move unexpectedly.

- Do not enable the downstream drive power amplifier until all units in the system have started.

Current and speed setpoint values can output in analogue form with the analogue outputs. The analogue output `ANA_OUT1` (parameter value "AnalogO1") can be configured as an analogue output for the current setpoint and the analogue output `ANA_OUT2` (parameter value "AnalogO2") can be configured as an analogue output for the setpoint speed value.

The user can also use the analogue outputs directly. This means that the voltage values can be set via field bus, for example.

For commissioning the analogue value can also be preset by the TLCT.

Setting parameters Analogue output 1

The "analogue setpoint current output" is set with the parameter `M1.Fkt_AOut1`.

Group.Name	Idx:Six dec (hex)	TLHMI	Explanation and unit []	Value range	Default value	R/W per.
M1.Fkt_AOut1	21:25 (15:19 _h)	4.5.36	Function Speed setpoint value at analogue output 1	INT16 0..1 0: freely available (TLCT commissioning) 1: Function Current setpoint value output	0	R/W per.

To obtain an analogue output voltage of +10 V, the associated current value must be scaled. The scaling can be set with the parameter

M1.AOut1Iscl. The set value indicates the current value at which the analogue output voltage reaches +10 V at analogue output 1.

Group.Name	Idx:Six dec (hex)	TLHMI	Explanation and unit []	Value range	Default value	R/W per.
M1.AOut1Iscl	21:26 (15:1A _h)	4.5.37	+10V output signal with specified setpoint current The following applies for control by field bus (=FB): (100 = 1A) The following applies for control otherwise (≠FB): [A]	INT16 0.. max. current for FB: 0..32767 for other: 0..327.67	300	R/W per.



The change in scaling is effective after the controller has been restarted.

If a function is not selected for the analogue output, a voltage value can be preset with the parameter M1.AnalogO1.

Group.Name	Idx:Six dec (hex)	TLHMI	Explanation and unit []	Value range	Default value	R/W per.
M1.AnalogO1	21:24 (15:18 _h)	2.3.3.7	Analogue output 1 [mV] (1000=1V) - voltage value from object default - voltage value for current setpoint	INT16 -10000 ... +10000	0	R/W-

Setting parameters Analogue output 2 The "analogue setpoint speed output" is set with the parameter M1.Fkt_Aout2.

Group.Name	Idx:Six dec (hex)	TLHMI	Explanation and unit []	Value range	Default value	R/W per.
M1.Fkt_AOut2	21:28 (15:1C _h)	4.5.39	Function Speed setpoint value at analogue output 2	INT16 0..1 0: freely available (TLCT commissioning) 1: Function Speed setpoint output	0	R/W per.

To obtain an analogue output voltage of +10 V, the associated speed value must be scaled. The scaling can be set with the parameter M1.AOut2Nscl. The set value indicates the speed value at which the analogue output voltage reaches +10 V at analogue output 2.

Group.Name	Idx:Six dec (hex)	TLHMI	Explanation and unit []	Value range	Default value	R/W per.
M1.AOut2Nscl	21:29 (15:1D _h)	4.5.40	+10V output signal with given speed [rpm]	INT16 0..14400 0 .. Max. speed = unit limits value of "Servomotor.N_maxM"	10000	R/W per.



The change in scaling is effective after the controller has been restarted.

If a function is not selected for the analogue output, a voltage value can be preset with the parameter M1.AnalogO2.

Group.Name	Idx:Six dec (hex)	TLHMI	Explanation and unit []	Value range	Default value	R/W per.
M1.AnalogO2	21:27 (15:1B _H)	2.3.3.8	Analogue output 2 [mV] (1000=1V) - voltage value from object default - voltage value for setpoint speed value	INT16 -10000.. +10000	0	R/W-

7.13 Position control with additional incremental encoder

Overview If an additional encoder separate from the motor (e.g. a glass scale), which must be connected with a RS422-C module on M1, is used, the position can be measured directly in the system. This means that the additional encoder is used as the actual position encoder instead of the encoder linked through M2. The commutation position and the actual speed are also calculated with the resolver or the Hiperface incremental encoder via M2.

If there is an additional incremental encoder as position sensor at M1, M1 cannot be used as reference value. The "electronic gear" or "reference movement to index pulse" operating mode cannot be executed.

Position control with M1 can be activated by:

- TLHMI hand-held operating unit
- TLCT Commissioning Software
- field bus

Operation with TLCT or TLHMI The commissioning software and the HMI hand-held operating unit support this operating function with special dialog boxes and menu items. For details see the manuals for the commissioning software and the TLHMI hand-held operating unit.

Activating position control on M1 The parameter M1.RS422-C is used to input the resolution of the incremental encoder in Inc/rev. For example, if an encoder with 2500 lines per revolution is used, the result is a resolution of 10000 Inc/rev because of the quadruple evaluation. In this case it must be set to 10000 Inc.

After disabling the power amplifier the parameter M1.M1_EncMod = 1 can be set for switching to the position control.

Group.Name	Idx:Six dec (hex)	TLHMI	Explanation and unit []	Value range	Default value	R/W per.
M1.RS422-C	21:9 (15:9 _h)	4.5.6	Resolution of the incremental encoder at module M1 [inc]	UINT16 100 .. 65535	16384	R/W per.
M1.M1_EncMod	28:27 (1C:1B _h)	4.1.15	Selection Position controller for actual position value	UINT16 0 .. 1 0 : position control by the encoder integrated in the motor 1: Position control with module M1	0	R/W per.

The position control is enabled at M1 if the two parameters M1.RS422-C and M1.M1_EncMod are permanently saved and the 24V power supply has been switched on again.

The parameter M1.M1M2PDLIM can be used to set the value for the following error limit value required for higher-order following error monitoring. The resolution of this position information is based on the resolution of the M1 position - as with all other positions. The parameter must be set for the following error, because on one hand varying mechanical ratios, such as slip, may occur between the motor encoder and external encoders and on the other hand the resolution of M1 cannot be set exactly. The position range in which the following error is cyclically reset depends on the limit value. If the following error between the M1

and the M2 position is greater than the following error limit value, a Quick-Stop is triggered.

Behaviour with deactivated power amplifier

With position control at M1 a continuous comparison is made between the motor position (sensor module, slot M2) and the measured direct position (sensor module, slot M1), which is used for position control. With a mechanical coupling between the sensors of the two position values this check represents a safety function, for example against failure of a RS422 sensor track connected to M1.

If the user consciously disconnects the mechanical coupling with the power amplifier active and a movement is run at only one sensor unit, this movement causes a monitoring error.

After switching the power amplifier to inactive status the monitoring is switched off. When the power amplifier is activated again, a position comparison is run between the two sensors and the monitoring is re-activated.

Availability This function is available in controllers from software version 1.205.

Group.Name	Idx:Six dec (hex)	TLHMI	Explanation and unit []	Value range	Default value	R/W per.
M1.rs422dir	21:38 (15:26 _h)	–	Inverting the M1 encoder signal for position control at M1	UINT16 0..1 0 = do not invert 1 = invert	0	R/W per.
M1.m1m2pdlim	21:39 (15:27 _h)	–	Following error limit value for higher-order following error monitoring between M1 and M2	UINT16 1..32000	1000	R/W per.
Status.PDIFM1M2	31:51 (1F:33 _h)	–	Read value, current following error between the M1 and M2 encoders corresponding to the resolution at the M1 encoder [inc] Can only be set with position control at the M1 encoder.	INT16	–	R/- -

The parameter `M1.RS422DIR` can be used to reverse the direction of the position counting at M1.

`Status.PDIFM1M2` can be used to read the current following distance between M1 and M2 encoders.

Deactivating position control on M1

The position control at M1 is disabled by setting the parameter `M1.M1_EncMod = 0` and saving it in non-volatile memory. In addition, the 24 V power supply must be restarted for deactivation.

Information on additional settings

The position controller parameters must not be changed, because the parameters, in SI units, are automatically converted to the internal format according to the resolution of M1. When positioning note that the unit for the position is preset by the incremental encoder at M1.

7.14 Setting parameters of the ESIM resolution

Availability This function is available in controllers from software version 1.205.

- Hardware availability* The ESIM resolution can be configured when the revision status of the ESIM module is greater than or equal to RS03 and on servomotors from serial number 11....
- Reading out the revision status* The revision status of an ESIM module can be read with TLCT using the function "Twin Line - Diagnostics - Unit hardware - Installed modules".
- Default resolution* Default resolution with quadruple evaluation of the A/B signal depending on the motor and encoder type used is 4096 increments per revolution.
- Setting parameters* The parameter is only available if an ESIM module with the required revision status is used.

Group.Name	Idx:Six dec (hex)	TLHMI	Explanation and unit []	Value range	Default value	R/W per.
M3.EsimResol	23:22 (17:16 _n)	-	Encoder simulation: Setting the resolution [Inc/rev]	UINT 16 0...5 Setting resolution: Stepper motor / AC servo 0: 4000 / 4096 1: 2000 / 2048 2: 1000 / 1024 3: 500 / 512 4: 250 / 256 5: 125 / 128	0	R/W per.

8 Diagnostics and troubleshooting

8.1 Operational status indicators and transitions

Status display in the unit The D2 LED on the motor terminal comes on when DC bus voltage is present.

The 7-segment display shows the operating status of the controller in coded form.

Display	Operating status
0	24 V switched on
1	Initialising the unit electronics
2	The power amplifier is not ready to switch on
3	Switching on the power amplifier is disabled
4	The power amplifier is ready to switch on
6	The unit is working in the selected mode
7	A Quick-Stop is being executed
8.9	An error has been detected and the error response activated
0 - A flashing	Indicates an error value
.	User program is running

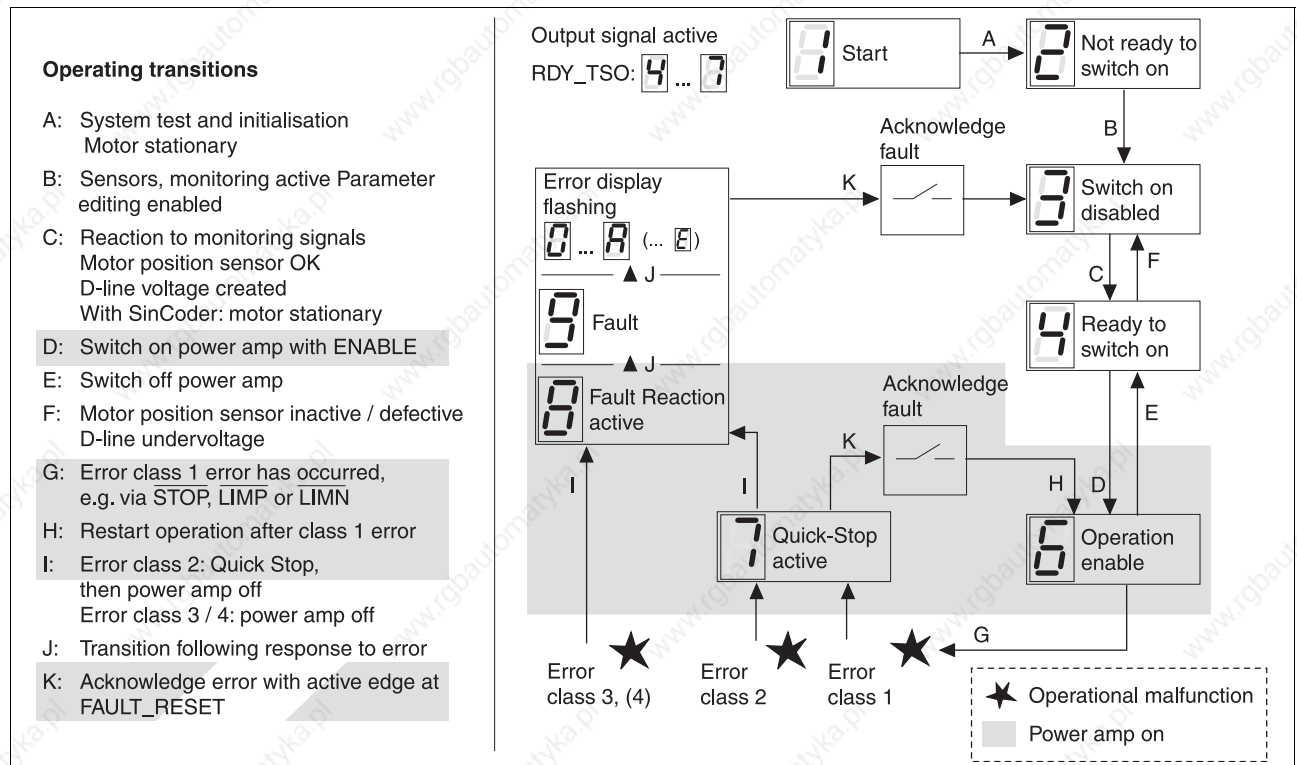

Figure 8.1 Operating states and transitions of the controller

Status transitions The conditions for switching between displayed operating states and the responses of the controller to an error follow a specified sequence.

Switching the operating status is controlled by the parameter `Commands.driveCtrl`.

Group.Name	Idx:Six dec (hex)	TLHMI	Explanation and unit []	Value range	Default value	R/W per.
Commands.driveCtrl	28:1 (1C:1h)	-	Control word for status change Write access triggers processing of the status machine	UINT16 0...15 Bit 0: Disable power amplifier Bit 1: Enable power amplifier Bit 2: Stop (QuickStop) Bit 3: FaultReset Bit 4: QuickstopRelease (TLC units only, internal accesses only) Bit 5: StopMotion (TLC units only) Bit 6...15: not assigned	0	R/W -

8.2 Diagnosis during commissioning



DANGER!

Electric shock, fire or explosion

- Only qualified personnel who are familiar with and understand the contents of this manual and the other relevant manuals are authorised to work on and with this drive system.
- Before working on the drive system:
 - Switch off power to all terminals.
 - Place a sign "DO NOT SWITCH ON" on the switch and lock to prevent switching on.
 - **Wait 6 minutes** (for discharge of DC bus capacitors).
 - Measure voltage between DC+ and DC- and check for <48V. (The DC bus LED is not a safe indication for absence of the DC bus voltage).
- Do not short-circuit DC bus or touch unshielded components or screws of the terminals with voltage present.
- Install all covers and close the housing doors before applying power.
- The motor generates voltage when the shaft is rotated. Lock the shaft of the motor to prevent rotation before starting work on the drive system.
- The system manufacturer is responsible for compliance with all applicable regulations relevant to earthing the drive system.
- Do not reach into the drive system (e.g. no pointed objects).

Operating status "2" display

If the controller stays in switching-on state "2", this indicates an internal fault in the unit, which can only be identified and corrected by your local representative.

Operating status "3" display

If the display does not change from '3' to '4', check the following:

- Is the power supply to the power amplifier switched on and does the voltage correspond to the details in the technical data?
- Is the motor encoder cable correctly wired and connected? Without the position sensor signal the controller cannot control the motor correctly.
- Is a resolver motor connected? The correct motor data must be read in before the power amplifier can be enabled.

Motor data for a resolver motor are transferred to the controller during start-up by the commissioning software.

Operating status display flashes

The unit has detected a fault. The next chapter contains a list with causes of error.

8.3 Error display and troubleshooting

- Error display* The cause of an operating malfunction is displayed
- by a flashing number in the seven-segment display
 - by the error response of the controller
 - in the commissioning software as an error message on the control bar and in the list of the error memory
 - in the display of the TLHMI hand-held operating unit as error message and in the list of the error memory.
 - bit-coded in the parameters `Status.FltSig`, `Status.FltSig_SR`, `Status.IntSigSR` and `Status.Sign_SR`.

The controller responds to an interruption by limit switch or stop signal with a Quick-Stop and displays an error message on the unit. The cause of the interruption is registered in the error memory and can be read with the TLHMI hand-held operating unit or the commissioning software.

- Resetting error messages* Once the error has been corrected, the message can be reset
- with TLCT using the "Reset" button
 - by calling special function blocks for error processing
 - by switching off the supply voltage of the controller.

Error response The controller triggers an error response in the event of a fault. Depending on the seriousness of the fault, the unit responds in accordance with one of the following error classes:

Error class	Response	Meaning
0	Warning	Message only, no interruption to movement operations
1	Quick-Stop	The motor stops with Quick-Stop, the power amplifier and controller stay switched on, stop control is activated.
2	Quick-Stop with shut-off	The motor stops with Quick-Stop, the power amplifier and controller switch off at standstill.
3	Fatal error	power amplifier and controller switch off. The unit can only be reactivated after the error has been corrected.
4	Uncontrolled operation	power amplifier and controller switch off. The error response can only be reset by switching off the unit.

Troubleshooting

Display	Error	Error class	Cause	Troubleshooting
dark	display dark	-	No power	Check power supply and fuses
	display dark	-	Power supply incorrectly connected	connect properly
1	Undervoltage	2	DC bus voltage below threshold value for Quick-Stop	Check or increase mains voltage
	Undervoltage	3	DC bus voltage below threshold value for switching off the drive	Check for power failure

0098 441 113 110, V1.00, 07.2004

Display	Error	Error class	Cause	Troubleshooting
2	Following error	1...3	Following error	Reduce load or acceleration, the error response can be configured with 'Flt_pDiff'
	Reference encoder in slot M1	1	cable fault to RS422 or sensor defective	Check encoder cable and encoder, replace cable
	Maximum motor speed	3	Exceeding the maximum motor speed under shift operation	Reduce vertical loading
3	Motor cable	3	Short circuit or earth fault in the motor line, motor current set too low in the controller, incorrect motor parameter, motor defect	Check connections, replace motor cable, select correct motor parameters.
4	position sensor	4	No signal from motor position sensor Motor connected with incorrect sensor or sensor defect	Check encoder cable and encoder, replace cable
5	Overvoltage	3	DC bus overvoltage	Use an external brake resistor
6	I ² t for power amplifier	0	I ² t monitoring in operation or at a standstill	Reduce the make time for peak current, load or peak torque, absorb the standstill torque with holding brake
	I ² t for motor	0	I ² t monitoring for motor	Reduce load, use a motor with a higher rated power
	I ² t for ballast	0	I ² t monitoring for ballast resistor	Reduce load, connect external resistor, improve ventilation
7	Overtemperature power amplifier	3	The power amplifier is overheating	Reduce make time for peak current, load or peak torque
	motor overtemperature	3	Motor is overheating Temperature sensor not connected	Allow motor to cool, reduce load, use motor with higher rated power, PTC / NTC sensor defect, check or replace motor-sensor cable
8	Watchdog	4	Internal system error	Switch unit off and on, replace unit
	Control system error	4	system error, e.g. division by 0 or time-out checks, insufficient EMC	Comply with EMC protective measures, switch unit off and on, contact your local service representative
9	Phase monitoring motor	3	Short circuit or interruption of motor phase Motor cable defect power amplifier transistor defect	Check motor cable and terminal, replace motor Replace unit
	Phase monitoring power system	1..3	Failure of one or more power phases	Check fuse and installation, error response can be adjusted with "Settings.Flt_AC"
A	Error at outputs	2	Short circuit at digital outputs, No 24V at signal interface IO 24 VDC	Check connections, test wiring Supply pin 7 and 8 with 24 V _{DC}
E	Controller system error	3	Cause of error corresponding to error number in error memory	Correction dependent on error number
	Controller system error	4	Cause of error corresponding to error number in error memory	Correction dependent on error number
c	Commutation error	3	Motor phases reversed or motor position sensor fault	Check connection of motor phases U,V,W, check connection of position sensor, if necessary replace motor
u	24 V power interruption	4	24 V power below 18.2 V	Ensure 24V DC power. Check short-term power interruptions during load change of power supply.

Display	Error	Error class	Cause	Troubleshooting
No ¹⁾	Limit switch	1	Limit switch is or was activated, wire interrupted	Traverse drive into movement zone, match positioning data to axis range, special message in error memory
	Stop	1	Stop signal activated, line interrupted	Check line for $\overline{\text{STOP}}$ terminal signal
	Node guarding	1	Connection monitoring for operating unit triggered	Check RS232 connection at controller
	Timeout	1	Protocol error	Timeout exceeded during exchange of data with manual control unit, restart transmission

1) No error display, operating status continues to be displayed.

IP54 controller The following errors can occur with the IP54 controller.

Display	Cause	Troubleshooting
dark	functions disabled due to condensation	allow unit to dry and reduce humidity

General The current and the last 20 error messages can be displayed with the TLCT and the TLHMI hand-held operating unit.

- TLCT: Error display ▶ Select "Twin Line - Diagnosis - Error memory". A dialog box which displays the error messages appears.

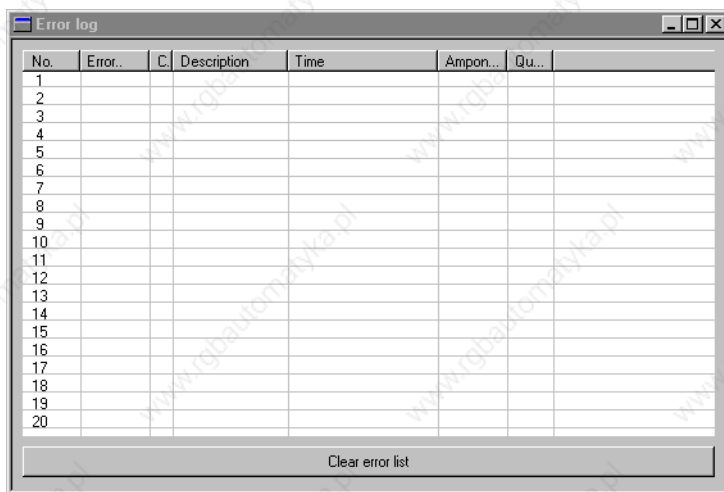

Figure 8.2 Error messages

Error messages are displayed showing status, error class, time when error occurred and a short description. The error number is given as a hexadecimal value.

Additional information is given in column Qu., Qualifier. For the error message "E1855 initialisation error at parameter lxSix -> qualifier" the Index/Subindex of the parameter at which the error was detected can be determined. You will find the parameter in the list of parameters on page 9-1.

As an example, if the qualifier is showing 00290023h, this represents the parameter `Motion.v_target0`.

A detailed error message is given in the following checksum error messages:

- 181Bh: "error while processing manual movement -> Qualifier"
- 181Fh: "error while processing reference movement -> Qualifier"
- 181Dh: "error while switching the user operating mode -> Qualifier".

You will find more detailed information in the Qualifier; e.g.00001846h, this is error message No. E1846 in the error list.

- ▶ Acknowledge the current error message with the 'Reset' button on the command bar of the program.

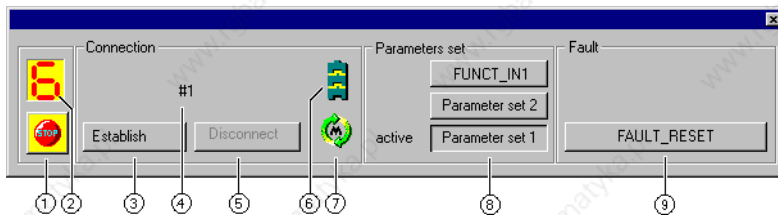

Figure 8.3 Reset button, 9

TLHMI: Error display ▶ Use menu item '2.4 Error' to change to the menu items for displaying error messages.

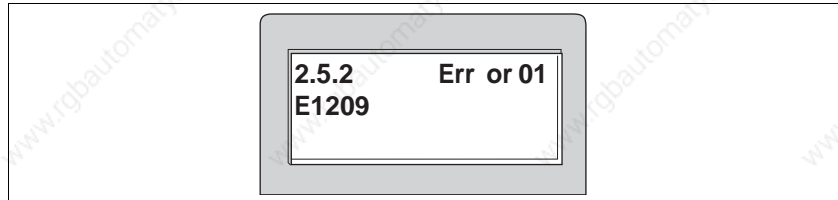

Figure 8.4 Displaying an error value

You can use the cursor keys to scroll through the error entries:

Menu item	Meaning
2.5.1 StopFault	Last cause of interruption
2.5.2 Error01	1st error entry, oldest report
2.5.3 Error02	2nd error entry, later report, if present
...	...

The meaning of the error values is shown in the manual for the TLHMI hand-held operating unit.

Field bus: evaluating error messages

In Fieldbus mode device errors are reported as asynchronous errors by the controller monitoring equipment. An asynchronous error is recognised by the status word 'fb_statusword'. Signal status '1' indicates an error or warning message. Details on the cause of the error can be determined via parameters.

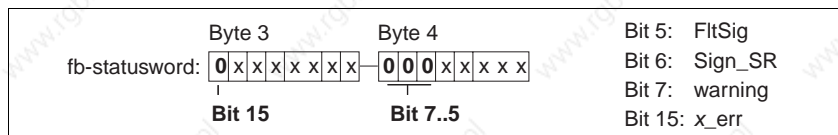

Figure 8.5 Error evaluation for asynchronous error

- Bit 5, "FltSig": Message from internal monitoring signal e.g. power amplifier overtemperature. Details with parameter Status.FltSig_SR and Status.IntSigSR
- Bit 6, "Sign_SR": Message from external monitoring signal, e.g. movement interrupted by input \overline{STOP} . Details of parameters- Status.Sign_SR
- Bit 7, "warning": Warning message from controller, e.g. I²t error power amplifier. Details with parameter Status.FltSig_SR and Status.IntSigSR

Besides asynchronous errors, synchronous errors are also reported in field bus operation, triggered by a communication error, e.g. by unauthorised access or an incorrect command. Both error types are described in the controller's Fieldbus manual.

Error display over the Fieldbus

The controller saves the last 20 error messages in a separate error memory. The current cause of error is also saved in the parameter `Status.StopFault`. The error messages are arranged in chronological order and can be read via index and subindex values:

Index	Meaning
900:1, 900:2, 900:3, ...	1. error entry, oldest report
901:1, 901:2, 901:3, ...	2. error entry, later report, if present
...	...
...919:1, 919:2, 919:3, ...	20. error entry. if present, the latest error value is found here

Further information on each fault report can be obtained from the subindex.

The additional information can be read with the parameter `ErrMem0.ErrQual`.

Group.Name	Idx:Six dec (hex)	TLHMI	Explanation and unit []	Value range	Default value	R/W per.
Status.StopFault	32:7 (20:7 _h)	2.5.1	Cause of last interruption, error number	UINT16 1..65535	–	R/- -
ErrMem0.ErrNum	900:1 (384:1 _h)	2.5.2	Coded error number	UINT16 0..65535	–	R/- -
ErrMem0.Class	900:2 (384:2 _h)	–	Error class	UINT16 0..65535	–	R/- -
ErrMem0.Time	900:3 (384:3 _h)	–	Error time since power amplifier switched on [s]	UINT32 0..4294967295	–	R/- -
ErrMem0.AmpOn-Cnt	900:4 (384:4 _h)	–	number of power amplifier switch-on cycles	UINT32 0..4294967295	–	R/- -
ErrMem0.ErrQual	900:5 (384:5 _h)	–	Additional information for assessing error	UINT32 0..4294967295	–	R/- -
Commands.del_err	32:2 (20:2 _h)	5.4	Deletion of all entries in error memory	UINT16 0..1	0	R/W-

The cause of error for every error message is coded as an error number in `Status.ErrNum`. The table from page 8-11 shows error numbers and their explanation.

Malfunctions in movement mode

Faults	Cause	Correction
The motor jerks briefly	Motor phases reversed	Check motor cable and connection: connect motor phases U, V and W in the same way on the motor and unit sides

Faults	Cause	Correction
No motor movement	The motor has seized	Release the motor brake
	Break in the motor cable	Check motor cable and connection. One or more motor phases are not connected.
	No torque	Set the parameters for max. current, max. speed to higher than zero
	Incorrect operating mode selected	Set the input signal and parameters for the operating mode you want

8.4 Table of error numbers

8.4.1 Error numbers from E1001 to E14FF

Error number	Error class	Meaning
E1001	0	Index outside valid range
E1002	0	Index is not supported
E1003	0	Subindex outside valid range
E1004	0	Subindex is not supported
E1005	0	Communication protocol: unknown service
E1006	0	Communication protocol: Service is not supported
E1007	0	Communication protocol: segment service not initialised
E1008	0	Parameter cannot be written
E1009	0	No read parameter
E100A	0	parameter out of range
E100B	0	Prior command not yet fully processed
E100C	0	Command not allowed while drive is active
E100D	0	Sequential table entries must be unequal
E100E	0	EEPROM structure too large
E100F	0	EEPROM defect
E1010	3	EEPROM booted
E1011	0	EEPROM error during read
E1012	0	EEPROM error during write
E1013	0	no valid parameter set
E1014	0	Block transfer without data
E1015	0	Illegal function
E1016	0	Cannot be written at this level
E1017	0	Maximum allowable current is exceeded
E1018	0	input value outside allowed speed range
E1019	0	mode dies not exist
E101A	0	service not supported
E101B	0	password not correct
E101C	0	Error in segment download
E101D	0	Error in S3 record
E101E	0	Flash write error
E101F	0	S-Record CRC Error
E1020	0	S-Record ID unknown
E1021	0	program checksum not correct
E1022	0	Bootstrap address error
E1023	0	wrong or missing module
E1024	0	movement interruption by LIMP
E1025	0	movement interruption by LIMN

Error number	Error class	Meaning
E1026	0	movement interruption by STOP
E1027	0	power amplifier not found
E1028	0	power amplifier not factory-adjusted
E1029	0	power-amplifier changed
E102A	0	motor not factory-adjusted
E102B	0	motor parameters missing
E102C	0	EEPROM re-initialised
E102D	0	Hiperface module not compensated or incorrectly compensated
E102E	0	No flash access when drive enabled
E102F	0	No valid operating system
E1030	0	Deviation at absolute position adjustment
E1031	0	command not allowed while drive is waiting for reference pulse from SinCoder
E1032	0	flash delete error (timeout)
E1033	0	Motor moves while unit is starting up
E1034	0	Drive not ready
E1035	0	EEPROM checksum error
E1036	0	SinCos EEPROM newly defined
E1037	0	SinCos EEPROM not correctly defined
E1038	0	Analogue input +-10V not adjusted
E1039	0	reference encoder module not available
E103A	0	EEPROM block length incorrect
E103B	0	activation of amplifier not permitted
E103C	0	incorrect amplifier type
E103D	0	parameter write error with active gear mode
E103E	4	no connection to the SAM module
E103F	4	transmission timeout to SAM module
E1040	3	transmission error to SAM module
E1041	4	SAM module not supported by obsolete CPU module
E1042	4	Update of SAM module required
E1043	4	Unit software must be updated for SAM support
E1044	4	Analogue channels not adjusted to analogue module
E1045	4	SAM module is in flash mode
E1046	4	SAM module is not in flash mode
E1047	4	Connection to the SAM module fault
E1048	4	Current measurement: Offset too high
E1200	0	Last service has not yet been processed
E1201	0	Receive buffer overrun
E1202	0	Serial interface break
E1203	0	Serial interface framing error
E1204	0	Serial interface overrun error

Error number	Error class	Meaning
E1205	0	Serial interface parity error
E1206	0	Trigger object is not valid
E1207	0	Trace not completely configured
E1208	0	Parameter value not valid
E1209	0	No access because upload active
E120A	0	No access because recording active
E120B	0	Buffer too small for trace configuration
E120C	0	parameter out of table range
E120D	0	function not implemented
E120E	0	error during access to Sincoder
E120F	0	Invalid data in HIPERFACE sensor non-volatile memory
E1210	0	No actual value model
E1211	0	WARNING: Actual value model replaced
E1212	0	Unknown Sincoder
E1213	0	EEPROM of HIPERFACE sensor too small
E1214	0	HIPERFACE sensor not adjusted
E1215	0	System: Watchdog
E1216	0	System: Illegal address
E1400	2	power up error
E1401	2	DC bus undervoltage limit value 1 reached: Quick-Stop
E1402	3	DC bus undervoltage limit value 2 reached: drive error
E1403	3	Motor earth fault
E1404	3	Motor short circuit
E1405	3	DC bus overvoltage
E1406	3	ballast resistor overtemperature
E1407	3	Motor overtemperature
E1408	3	Overtemperature power amplifier
E1409	0	i2t power amplifier monitoring
E140A	4	Commutation error
E140B	0	i2t motor monitoring
E140C	0	i2t monitoring of ballast resistor
E140D	3	motor phase not connected
E140E	3	line phase not connected
E140F	4	system watchdog
E1410	4	DSP internal system fault
E1411	3	Safe stop
E1412	0	Serial interface: transmission error
E1413	3	speed limit exceeded
E1414	3	Slot M1: reference quantity signal not correctly connected
E1415	3	Slot M2: position sensor for current motor position not correctly connected

Error number	Error class	Meaning
E1416	3	following error limit reached
E1417	4	24VDC power interruption
E1418	0	position following error
E1419	2	I/O error
E141A	1	limit switch incorrectly wired
E141B	0	warning motor overtemperature
E141C	0	warning power amplifier overtemperature
E141D	0	unit overtemperature
E141E	0	SAM warning
E141F	0	Nodeguarding

8.4.2 Error numbers from E1500 to E1CFF

Error number	Error class	Meaning
E1500	1	SAM: error of class 1 forced
E1501	2	SAM: error of class 2 forced
E1502	3	SAM: error of class 3 forced
E1503	4	SAM: error of class 4 forced
E1504	3	SAM: error during safe standstill: insufficient braking ramp (Quick-Stop)
E1505	1	SAM: safe mode stop violated
E1506	1	SAM: safe reduced setup speed exceeded
E1507	1	SAM: safe limited continuous jogging exceeded
E1508	1	SAM: safe limited absolute position exceeded
E1509	1	SAM: end positions exceeded
E150A	2	SAM: EMERGENCY STOP triggered
E150B	0	SAM: not ready for Fault Reset
E150C	0	SAM: not ready for SAM disable
E150D	3	SAM: safe service stop after error violated
E150E	0	SAM: parameters cannot be read
E150F	0	SAM: parameters cannot be written in this status
E1510	0	SAM: incorrect password
E1511	0	SAM: timeout during parameter download (default values loaded)
E1512	0	SAM: parameter not present
E1513	0	SAM: parameter checksum cannot be written in this status
E1514	0	SAM: parameter checksum incorrect (default values loaded)
E1515	0	SAM: Warning: overtemperature
E1516	0	SAM: Warning: Overtemperature
E1517	2	SAM: 24 VDC overvoltage
E1518	2	SAM: 24VDC undervoltage
E1519	2	SAM: short circuit to GND at channel A outputs

Error number	Error class	Meaning
E151A	4	SAM: System error: 5V power supply
E151B	4	SAM: System error: 5V undervoltage
E151C	2	SAM: overvoltage SAM24VDC (SW)
E151D	2	SAM: SAMSTART: max. allowable pulse duration exceeded
E151E	4	SAM: System error: RAM (cross connection)
E151F	4	SAM: System error: stack overflow
E1520	4	SAM: System error: program sequence control (communication)
E1521	4	SAM: System error: program sequence control (idle task)
E1522	4	SAM: System error: program sequence control (MS task)
E1523	2	SAM: output cross connection
E1524	2	SAM: System error: Input
E1525	4	SAM: System error: PROM checksum error
E1526	0	SAM: parameter out of range
E1527	2	SAM: parameter block checksum error
E1528	2	SAM: System error: SPI Framing Error
E1529	2	SAM: unequal input states
E152A	2	SAM: short circuit at output (unequal states)
E152B	3	SAM: error in position detection (unequal values)
E152C	3	SAM: error in speed detection (unequal values)
E152D	2	SAM: error in IO current measurement
E152E	2	SAM: System error: error in SAM24VDC measuring (unequal values)
E152F	2	SAM: System error: power amplifier enable/SAM jumper
E1530	4	SAM: System error: SAM24VDC overvoltage shut-off
E1531	2	SAM: System error: SPI short circuit
E1532	2	SAM: System error: UART short circuit
E1533	0	SAM: EEPROM checksum incorrect (default values loaded)
E1534	0	SAM: SAM module replaced (default values loaded)
E1535	4	SAM: System error: position capture (commutation position)
E1536	4	SAM: unequal parameter checksum
E1537	0	SAM: SAM boot program: illegal address
E1538	1	SAM: safe reduced automatic speed exceeded
E1539	2	SAM: SAMSTART input low instead of high (Auto Start)
E153A	2	SAM: SAMSTART input high instead of low (Safe Start)
E153B	2	SAM: safety door acknowledgement: max. allowable pulse duration exceeded
E153C	4	SAM: System error: unequal status of SAM status machines
E153D	0	SAM: FAULT RESET not possible (error cannot be acknowledged)
E153E	2	SAM: incorrect voltage at inputs
E153F	2	SAM: output AUX_OUT_A (cross connection to other output)
E1540	2	SAM: output INTERLOCK_OUT (cross connection to other output)
E1541	2	SAM: output RELAY_A (cross connection to other output)

Error number	Error class	Meaning
E1542	2	SAM: output SAFETY24V_A (cross connection to other output)
E1543	2	SAM: output AUX_OUT_A (cross connection to 24V)
E1544	2	SAM: output INTERLOCK_OUT (cross connection to 24V)
E1545	2	SAM: output RELAY_A (cross connection to 24V)
E1546	2	SAM: output SAFETY24V_A (cross connection to 24V)
E1547	2	SAM: System error: channel A output driver defective
E1548	2	SAM: System error: input ESTOP_A
E1549	2	SAM: System error: input GUARD1_A
E154A	2	SAM: System error: input SETUPENABLE_A
E154B	2	SAM: System error: input SETUPMODE_A
E154C	2	SAM: System error: input SAFETY_REF_A
E154D	2	SAM: System error: input GUARD2_A
E154E	2	SAM: System error: input INTERLOCK_IN_A
E154F	2	SAM: System error: input GUARD1CONF_A
E1550	2	SAM: short circuit at channel B outputs to GND
E1551	4	SAM: System error: UART overrun/framing error
E1552	2	SAM: ResEnc (encoder) is configured with 0
E1553	2	SAM: System error: CPU synchronisation
E1554	2	SAM: no moor motion since 36h
E1555	2	SAM: System error: timeout high-priority tests (5 sec)
E1556	2	SAM: System error: timeout low-priority tests
E1557	2	SAM: dec_Qstop (minimum deceleration) is configured with 0
E1558	2	SAM: output AUX_OUT_B (cross connection to other output)
E1559	2	SAM: output INTERLOCK_OUT (cross connection to other output)
E155A	2	SAM: output RELAY_B (cross connection to other output)
E155B	2	SAM: output SAFETY24V_B (cross connection to other output)
E155C	2	SAM: output AUX_OUT_B (cross connection to 24V)
E155D	2	SAM: output INTERLOCK_OUT (cross connection to 24V)
E155E	2	SAM: output Relay_B (cross connection to 24V)
E155F	2	SAM: output SAFETY24V_B (cross connection to 24V)
E1560	2	SAM: System error: channel B output driver defective
E1561	2	SAM: System error: input ESTOP_B
E1562	2	SAM: System error: input GUARD1_B
E1563	2	SAM: System error: input SETUPENABLE_B
E1564	2	SAM: System error: input SETUPMODE_B
E1565	2	SAM: System error: input SAFEFUNCIN_B
E1566	2	SAM: System error: input GUARD2_B
E1567	2	SAM: System error: input INTERLOCK_IN_B
E1568	2	SAM: System error: input GUARD1CONF_B
E1569	2	SAM: System error: SAM24VGND sense interrupted

Error number	Error class	Meaning
E156A	4	SAM: System error: Temperature sensor
E156B	2	SAM: 24VDC - SAM24VDC difference too great
E156C	2	SAM: SAM24VDC overvoltage (HW)
E156D	4	SAM: temperature shutoff (HW)
E156E	4	SAM: System error: inequality in SamOpMode
E156F	2	SAM: System error: AD converter
E1570	4	SAM: unequal software versions
E1571	3	SAM: safe mode stop violated in case of error
E1572	4	SAM: System error: software not compatible to hardware
E1573	1	SAM: error during safe deceleration: insufficient braking ramp (PLC)
E1574	2	SAM: safe service stop repeatedly violated in sequence
E1575	4	SAM: error accumulation during safe standstill: insufficient braking ramp (Quick-Stop)
E1576	3	SAM: INTERLOCK_IN is not high (time out when t_Relay=2)
E1577	2	SAM: input INTERLOCK_IN high although configured to ignore
E1578	2	SAM: setup speed (n_maxRed) is greater than automatic speed (n_maxAuto)
E1579	4	SAM: System error: unknown status of SAM status machine
E157A	2	SAM: SAM24VDC undervoltage
E157B	4	SAM: System error: ENABLE_ALL 5VGate shutoff
E157C	4	SAM: System error: ENABLE_ALL temp shutoff
E157D	4	SAM: System error: asynchronous communication (UART/SPI)
E157E	4	SAM: System error: RAM (Bit)
E157F	2	SAM: SAM24VGND not connected
E1800	0	Subindex not available (no function linked)
E1801	0	write access not allowed because of access level
E1802	0	Incorrect password for commissioning or service
E1803	0	Illegal interface initialisation parameter
E1804	4	Memory for receive/sent buffer not assigned
E1805	2	Interface not initialised (com_init aufr.)
E1806	0	precondition not met
E1807	0	Error in selection parameter
E1808	2	send buffer too small
E1809	2	send string not converted
E180A	2	receive buffer too small
E180B	0	Serial interface: overrun error
E180C	0	Serial interface: framing error
E180D	0	Serial interface: parity error
E180E	0	Serial interface: receive error
E180F	0	Serial interface: protocol error
E1810	0	Serial interface: transmission error
E1811	0	access allowed only with active axis mode

Error number	Error class	Meaning
E1812	4	access to non-configured object (this=NIL)
E1813	0	DSP clock missed once
E1814	4	DSP clock total failure
E1815	0	trace object invalid
E1816	1	resource or function not ready
E1817	0	parameter value incorrect
E1818	0	Not calculable value
E1819	0	Function only allowed at standstill
E181A	0	Position overrun present/occurred
E181B	0	Error during processing manual movement ->Qualifier
E181C	0	Actual position is not yet defined
E181D	0	External source is active
E181E	0	drive is interrupted or blocked
E181F	0	Error while processing reference movement ->Qualifier
E1820	1	error in processing position list
E1821	0	Function not available with this unit type
E1822	0	Reference movement is active
E1823	0	CanMaster: invalid object number
E1824	0	CanMaster: invalid object ID
E1825	0	Processing not allowed in current axis mode
E1826	0	Error in connection with software limit switch
E1827	0	Recording position of hardware limit switch not defined
E1828	0	limit switch not enabled
E1829	0	Reference movement error with /LIMP
E182A	0	Reference movement error with /LIMN
E182B	0	CanMaster: invalid object attribute
E182C	0	CanMaster: DefineObject reports error
E182D	0	CanMaster: initialisation reports error
E1832	4	HWU_install PSOS error
E1833	4	Sys. error no space for work data
E1834	0	field bus module: FIFO debug message
E1835	4	field bus module: FIFO timeout
E1836	4	field bus module: error during boot procedure
E1837	4	field bus module: error during initialisation
E1838	4	field bus module: incorrect communication parameter
E1839	4	field bus module: indicates error
E183A	4	field bus module: does not indicate
E183B	4	field bus module: unknown FIFO object received
E183C	4	field bus module: state machine indicates error
E183D	4	Service request write object to DSP with error

Error number	Error class	Meaning
E183E	4	service request read object to DSP with error
E1840	4	Data interfaces do not match (size)
E1841	0	change to new user mode still active
E1842	4	Overrun with path calculation for ramp description
E1843	0	Interruption/QuickStopActive by LIMP
E1844	0	Interruption or QuickStop Active by LIMN
E1845	0	Interruption or QuickStop Active by REF
E1846	0	Interruption or QuickStop Active by STOP
E1847	0	Ext. monitoring signal LIMP with neg. direction of rotation
E1848	0	Ext. monitoring signal LIMN with pos. direction of rotation
E1849	0	internal position range exceeded
E184A	4	DSP bootstrap loader timeout
E184B	4	DSP indicates wrong program version
E184C	3	EEPROM contains corrupt data
E184D	4	internal overflow
E184E	0	Axis access by other interface locked
E184F	0	reference movement error by HWSTOP
E1850	0	reference movement error at/by REF
E1851	3	error during gear calculation
E1852	3	DSP timeout
E1853	3	Illegal value change in gear calculation
E1854	0	Command not allowed during processing (xxxx_end=0)
E1855	2	Initialisation error with parameter IxSix ->Qualifier
E1856	0	access only possible with PowerDisabled
E1857	0	access possible only with PowerEnabled
E1858	0	Quick-stop active status activated
E1859	0	FaultReaction status or fault active
E185A	0	processing only possible in gear mode
E185B	0	input AUTOM or automatic processing active
E185C	0	input AUTOM inactive or manual processing active
E185D	0	login still unsuccessful
E185E	0	PSOS task not found
E185F	0	Setpoint position generation interrupted
E1860	0	interruption or QuickStopActive by SWLIM
E1861	0	interruption or QuickStop Active by SWSTOP
E1862	0	interruption or QuickStopActive by internal SWSTOP
E1863	0	access only possible in OperationEnable status
E1864	0	reference encoder module not available
E1865	0	more then one HWLIM/REF signal active
E1866	0	call with direction bits=0 before new manual movement required

Error number	Error class	Meaning
E1867	0	List control: finishing number set lower than starting number
E1868	0	List control: position values not in sequential ascending or descending order
E1869	0	List control: current position is behind position of last selected list entry
E186A	0	List control: signal list is active
E186B	0	Current list control disabled because of change of user operating mode
E186C	2	Timeout while waiting until the drive is in the standstill window
E186D	1	Error while switching the user operating mode -> Qualifier
E186E	4	Device type was not defined
E186F	1	Processing in current operating status of status machine not possible
E1870	0	External memory module not present
E1871	1	illegal set number
E1872	0	External Memory FRAM error
E1873	0	internal position adaptation to 0 because of range overrun
E1874	0	External Memory FLASH error
E1875	0	external memory RAM error
E1876	1	unable to process synchronous start signal
E1877	0	reference switch /REF not found between /LIMP and /LIMN
E1878	0	Reference movement to /REF with reversal of rotation direction, illegal limit switch /LIM enabled
E1879	0	Reference movement to /REF without reversal of rotation direction, tripping of /LIM or /REF not allowed
E187A	0	processing not possible: invalid or missing actual position encoder
E187B	0	processing not possible during reference movement to index pulse
E187C	0	processing not possible: fast position detection is active
E187D	1	index pulse not found
E187E	1	Reproducibility of index pulse motion insecure, index pulse too close to switch
E187F	0	Access through this operator channel not permitted
E1880	0	CANopen object directory overrun
E1881	0	Processing not possible because of invalid or missing setpoint position encoder at M1
E1882	0	Movement interrupted by StopMotion
E1A00	0	RAM too small for internal curve table
E1A01	0	Interpreter error: no data for interpretation
E1A02	0	Interpreter error: no C_NUM token in first line
E1A03	0	Interpreter error: invalid token
E1A04	0	Interpreter error: header // not found
E1A05	0	Interpreter error: invalid value
E1A06	0	Interpreter error: no C_COUNT token in last header line
E1A07	0	Interpreter error: no slave value entered
E1A08	0	Interpreter error: not enough slave values
E1A09	0	Interpreter error: mandatory entries in header incomplete
E1A0A	0	Interpreter error: invalid value of C_COUNT parameter

Error number	Error class	Meaning
E1A0B	0	Imprecision during calculation of slave modulo value at curve no. ->Qualifier
E1A0C	0	Curve already present
E1A0D	0	Illegal curve number
E1A0E	0	Curve not present
E1A0F	0	ME less than 0 or greater than max. master value
E1A10	0	MS less than 0 or greater than max. master value
E1A11	0	MA less than 0 or greater than max. master value
E1A12	0	Error during conversion of user-defined curve to internal curve in line ->Qualifier
E1A13	0	ME greater than MS
E1A14	0	No download file with curve data
E1A15	0	Activation of CamCtrlBlock: configured curve is not available
E1A16	0	Activation of CamCtrlBlock: C_M_VAL_EXPO or C_S_VAL_EXPO not identical in curve headers
E1A17	0	Activation of CamCtrlBlock: C_COUNT not identical in curve headers
E1A18	0	Activation of CamCtrlBlock: C_M_VAL_MAX not identical in curve headers
E1A19	0	Illegal master values on setting master or slave position compensation range (Ctrlx.CorrStart or Ctrlx.CorrEnd)
E1A1A	0	Illegal master values for master mark recording range (Ctrlx.MsMarkSta or Ctrlx.MsMarkEnd)
E1A1B	0	Illegal master values for slave mark recording range (Ctrlx.SIMarkSta or Ctrlx.SIMarkEnd)
E1A1C	0	Curve number in file more than once
E1A1D	0	Curve interpreter already active
E1A1E	0	Error in C_CYCLE_TIME header entry: invalid value
E1A1F	0	Invalid master simulation mode
E1A20	0	Activation of CamCtrlBlock: additional call during profiling
E1A21	0	Processing not allowed if CamCtrlBlock is in status 'work'
E1A22	0	Used CamCtrlBlock not in status 'ready'
E1A23	0	Illegal number of curve points for internal curve data
E1A24	0	Illegal setting of master cycle length (Ctrlx.MsTkNum or Ctrlx.MsTkDenom)
E1A25	0	Illegal setting of slave cycle length (Ctrlx.SITkNum or Ctrlx.SITkDenom)
E1A26	0	Illegal setting of slave cycle modulo length (incl. Ctrlx.SIMdNum or Ctrlx.SIMdDenom)
E1A27	0	Illegal setting of master reference
E1A28	0	Illegal setting of slave reference
E1A29	0	Write access only allowed in status 'WAIT_FOR_REFERENCE'
E1A2A	0	Function allowed only at master simulation standstill
E1A2B	0	Internal position adaptation of master simulation to 0 because range exceeded
E1A2C	0	Actual position of master simulation not yet defined
E1A2D	0	Illegal setting for referencing at master cycle signal (Capture.TrigSign or Capture.TrigType)
E1A2E	0	Profiling not possible during referencing or fast position capture of cam profile
E1A2F	1	Illegal change of master position
E1A30	1	Illegal change of slave position

Error number	Error class	Meaning
E1A31	0	Profiling mode for master position compensation not set (CamGlobal.MsCorrMod)
E1A32	0	Profiling mode for slave position compensation not set (CamGlobal.SICorrMod)
E1A33	0	Activation of CamCtrlBlock: max. slave value in couple/uncouple curve greater than in normal curve
E1A34	0	Curve data incompatible to current operating system
E1A35	1	New CamCtrlBlock during conversion not in status 'ready'
E1A36	0	CAM_LAST_ERROR
E1C00	0	Flash not in status IDLE
E1C01	0	The CFlash class is not initialised
E1C02	0	Flash: invalid segment number
E1C03	0	Flash: file name too long
E1C04	0	Flash: Checksum error in the boot configuration
E1C05	0	Flash: error during deletion
E1C06	0	Flash: command cannot be executed in current operating mode
E1C07	0	Flash: error during write
E1C08	0	Flash: Invalid handle
E1C09	0	Flash: not enough free memory. Delete files with browser command 'filedelete'!
E1C0A	0	Flash: invalid segment content
E1C0B	0	No external memory module
E1C0C	0	Firmware and application program incompatible
E1C0D	0	Flash: no valid user-defined data
E1C0E	0	Flash: no data
E1C0F	0	Flash: file not present
E1C10	0	Memory management: invalid memory region
E1C11	0	Memory management: Address out of valid memory range
E1C12	0	Memory management: Out of range
E1C13	0	Memory management: Invalid initialisation
E1C20	0	Insufficient memory space for user-defined data
E1C21	0	Invalid memory address from application
E1C30	0	Axis busy
E1C31	0	Stop axis when reaching a breakpoint
E1C32	0	Error in current hardware configuration
E1C33	0	CAN module not present
E1C34	0	Lower limit Array undershoot
E1C35	0	Upper limit Array exceeded
E1C36	0	PSOS error message
E1C37	0	Invalid retaining range
E1C38	0	Application: division by zero
E1C39	0	Cycle time exceeded in application
E1C3A	0	Insufficient marker range

Error number	Error class	Meaning
E1C3B	0	Invalid function call
E1C40	0	Axis not in valid operating mode
E1C41	0	Incorrect axis operating mode
E1C42	0	User-defined data backup active
E1C43	0	Input parameter outside value range
E1C44	0	Parameter not allowed with local axis
E1C50	0	The following must be set in the TLCT: parameter >M4->profilCan = CAN bus
E1C51	0	CAN SDO buffer overflow
E1C52	0	CAN invalid node ID
E1C53	0	CAN invalid object
E1C54	0	Error of an external CAN node
E1C55	0	CAN object not initialised
E1C56	0	Maximum number of CAN objects reached
E1C57	0	CAN invalid PDO number
E1C58	0	CAN PDO variable > 4 function code was not transferred
E1C59	0	CAN synchronous time window > SYNC period
E1C5A	0	CAN unknown NMT service
E1C5B	0	CAN action in current NMT status not allowed
E1C5C	0	CAN Heartbeat time monitoring exceeded
E1C5D	0	CAN Exceeded the number of Heartbeat consumers
E1C5E	0	Command is not permitted in the current CAN state
E1C5F	0	Timeout SDO response
E1C60	0	No event task initialised
E1C71	0	Invalid hardware configuration
E1C72	0	Invalid module in hardware configuration
E1C73	0	Invalid parameter in hardware configuration
E1C74	0	Invalid data type in hardware configuration
E1C75	0	Invalid data length in hardware configuration

8.4.3 Error numbers from E2000 to E20FF

Error number	Error class	Meaning
E2000	0	FIRST_TLCT_ERROR
E2001	0	Timeout
E2002	0	Incorrect data received
E2003	0	Incorrect frame received
E200A	0	SCAN LOGIN has failed
E200C	0	TIMEOUT during SCAN LOGIN
E200D	0	SCAN LOGOUT has failed
E200E	0	TIMEOUT during SCAN LOGOUT

Error number	Error class	Meaning
E2015	0	Polling error
E2016	0	Timeout when polling the unit
E2017	0	LOGIN has failed
E2018	0	TIMEOUT during LOGIN
E2019	0	Reading of object list has failed
E201A	0	TIMEOUT while reading object list
E201B	0	Reading control objects has failed
E201C	0	TIMEOUT while reading control objects

9 Parameters

9.1 Parameter groups

<i>Settings</i>	Characteristics of input and output signals of the signal interface, change of error responses, gear factors, parameters for the ± 10 V interface and general control settings
<i>Commands</i>	Transmission of parameter sets, system settings for power amplifier, controller
<i>PA</i>	Parameters of the power amplifier, system settings
<i>Servomotor</i>	Motor-specific settings. These settings cannot be changed with the TLHMI hand-held operating unit.
<i>CtrlBlock1, CtrlBlock2</i>	Settings for the control loops, stored in control parameter data sets 1 and 2.
<i>Motion</i>	Parameter settings for all modes: jerk filter, direction of rotation, software limit switches, standardisation and ramp settings.
<i>Manual</i>	Parameter settings for manual mode
<i>VEL</i>	Settings for speed mode
<i>PTP</i>	Settings for Point-to-Point mode
<i>Gear</i>	Settings for electronic gear mode with superimposed offset
<i>Home</i>	Settings for referencing mode
<i>CurrentControl</i>	Settings for current control mode
<i>Oscillator</i>	Settings for oscillator mode
<i>Teach</i>	Settings for Teach-In
<i>List</i>	Settings for the list-controlled operation function mode
<i>List1Data0..List1Data63</i>	List data input data
<i>List2Data0..List2Data63</i>	List data input data
<i>Capture</i>	Settings for the operating function for capturing position data
<i>I/O</i>	Switching states of inputs and outputs of the signal interface
<i>M1</i>	Settings for modules in slot M1
<i>M2</i>	Settings for modules in slot M2
<i>M3</i>	Settings for modules in slot M3
<i>M4</i>	Settings for modules in slot M4
<i>Status</i>	System settings: Device-specific and current parameters such as temperature values of the power amplifier, motor and internal ballast resistor, control loop parameters, and setpoint and actual values
<i>ErrMem0...ErrMem19</i>	Storage of last 20 error messages. Older messages are shifted towards ErrMem0.

9.2 Parameter display

Parameter display The parameter view contains information that is required for unique identification of a parameter. The parameter display can also provide information on setting options, presets and parameter properties. It is important to note that the parameters are grouped in functionally related blocks, referred to as parameter groups. A parameter display has the following features:

Group.Name	Idx:Six dec (hex)	TLHMI	Explanation and unit []	Value range	Default value	R/W per.
VEL.velocity	36:1 (24:1 _h)	3.1.2.1	Start of speed change with transfer of setpoint speed [usr]	INT32 -2147483648 ..2147483647	–	R/W-

Group.Name Parameter name consisting of the name of the parameter group ("Group") and the name of the specific parameter ("Name").

Idx Index value of a parameter

Six Subindex value of a parameter

TLHMI Menu item of the 3-level menu structure in the TLHMI that corresponds to a parameter.

Explanation and unit [] Detailed explanation of the parameter and its unit.

Value range In the case of parameters without values the applicable value range depends on the data type.

Data type	Byte	Min value	Max value
INT16	2 Byte / 16 Bit	-32768	32767
UINT16	2 Byte / 16 Bit	0	65535
INT32	4 Byte / 32 Bit	-2.147.483.648	2.147.483.647
UINT32	4 Byte / 32 Bit	0	4.294.967.295

Default values Preset values for the parameters before initial commissioning, factory settings.

R/W Note on reading and writing the values
"R/-" values are read-only
"R/W" values are read and write.

per. Information on whether the value of the parameter is non-volatile, i.e. is retained in memory after switching the unit off. The user must back up the data in the non-volatile memory before switching off the device to ensure that the value is saved in non-volatile memory.

Instructions on input of values:

The values "max.current" and "max.speed" in "value range" correspond to the lower maximum values of power amplifier and motor. The unit limits automatically to the lower value.

Temperatures in Kelvin [K] = temperature in degrees Celsius [°C] + 273
e.g. 358K = 85°C

Use the specifications relevant for controlling the unit through the particular access channel.

Access channel	Specifications
Fieldbus	Idx:Sidx
TLHMI	Menu items under "TLHMI"
TLCT	'Group Name', e.g. Settings.SignEnabl

Note that the value ranges for the different access channels may differ, e.g. value range for `CurrentControl.curr_targ`

- The following applies for control by Fieldbus (=FB):
-32768... +32767 (100=1Apk)
- The following applies for other control (≠FB):
-327.68... +327.67 [Apk].

9.3 Overview Parameters



Please note that more detailed information is available in the separate operating manual for the cam profile operating mode.

9.3.1 Parameter group "Settings"

Max. current: Smaller value of "servomotor.l_maxM" and "PA.l_maxPA"

Max. speed: Value limited by unit of "servomotor.n_maxM"

Group.Name	Idx:Six dec (hex)	TLHMI	Explanation and unit []	Value range	Default value	R/W per.
Settings.name1	11:1 (B:1 _h)	–	User device name 1	UINT32 0..4294967295	538976288	R/W per.
Settings.name2	11:2 (B:2 _h)	–	User device name 2	UINT32 0..4294967295	538976288	R/W per.
Settings.Password	11:3 (B:3 _h)	1.3	Password for configuring with a hand-held operating unit	UINT16 0..9999 0: No password protection	0	R/W per.
Settings.l_RefScal	12:3 (C:3 _h)	4.1.20	Setpoint current at 10V input signal For control by field bus (=FB) this applies: (100=1Apk) For other types of control (≠FB) this applies: [Apk]	UINT16 0..max. Current 0..32767 0..327.67	300	R/W per.
Settings.p_maxDiff	12:11 (C:B _h)	4.1.23	Maximum permitted following error of the position controller [Inc]	UINT32 0..131072 8 motor revolutions With resolver motor max. 8*4096 Inc	16384	R/W per.
Settings.p_win	12:13 (C:D _h)	4.1.24	Standstill window, permissible control deviation [Inc]	UINT16 0..32767	16	R/W per.
Settings.p_winTime	12:15 (C:F _h)	4.1.25	Time for which the control deviations must remain in the standstill window for standstill to be reported [ms] 0: Standstill monitoring switched off	UINT16 0..32767	0	R/W per.
Settings.f_Chop	12:17 (C:11 _h)	4.1.21	Switching frequency of power module, (default value=1; 0 for TLxx38)	UINT16 0: 4kHz 1: 8kHz 2: 16 kHz,	1	R/W per.
Settings.p_winTout	12:21 (C:15 _h)	4.1.27	Time within which the standstill must be reported [ms] 0: disabled	UINT16 0 .. 32767	0	R/W per.
Settings.t_brk_off	12:22 (C:16 _h)	4.1.36	Time delay for holding brake release [ms]	UINT16 0 .. 200	0	R/W per.
Settings.t_brk_on	12:23 (C:17 _h)	4.1.37	Time delay for controller with holding brake applied [ms]	UINT16 0 .. 100	0	R/W per.
Settings.offset_0V	20:58 (14:3A _h)	4.1.38	Offset for linear shift of the 0V input voltage [mV]	INT16 -5000.. +5000	0	R/W per.

Group.Name	Idx:Six dec (hex)	TLHMI	Explanation and unit []	Value range	Default value	R/W per.
Settings.win_10V	20:59 (14:3B _h)	4.1.39	Voltage window within which is analogue value is equal to 0 [mV] Example: Setting value of 20 mV means that the range - 20 mV to + 20 mV is interpreted as 0 mV	UINT16 0..1000	0	R/W per.
Settings.SignEnabl	28:13 (1C:D _h)	4.1.10	Signal release for monitoring inputs 0: blocked 1: enabled	UINT16 0..15 Bit 0 : LIMP Bit 1: LIMN Bit 2: STOP Bit 3: REF	7	R/W per.
Settings.SignLevel	28:14 (1C:E _h)	4.1.11	Signal level for monitoring inputs 0: response at 0 level 1: response at 1 level	UINT16 0..15 Bit 0 : LIMP Bit 1: LIMN Bit 2: STOP Bit 3: REF	0	R/W per.
Settings.SignQstop	28:20 (1C:14 _h)	4.1.26	Control signals that trigger a Quick-Stop via 0: deceleration ramp 1: Quick-Stop ramp	UINT16 Bit0: LIMP Bit1: LIMN Bit2: STOP Bit3: REF Bit4..6: - Bit7: SW_STOP	0	R/W per.
Settings.l_maxSTOP	28:22 (1C:16 _h)	4.1.3	Current limit for quick stop (100=1A _{pk})	UINT16 0..max. Current 0..29999	1000	R/W per.
Settings.Flt_AC	28:23 (1C:17 _h)	4.1.12	Error response to power failure of 2 phases	UINT16 1..3 1: error class 1 2: error class 2 3: error class 3	3	R/W per.
Settings.Flt_pDiff	28:24 (1C:18 _h)	4.1.13	Error response to following error	UINT16 0..3 0: error class (warning) 1: error class 1 2: error class 2 3: error class 3	3	R/W per.
Settings.TL_BRC	28:26 (1C:1A _h)	4.1.14	External ballast resistor controller TLBRC	UINT16 0..1 0: not connected 1: connected	0	R/W per.
Settings.Commut-Chk	28:28 (1C:1C _h)	-	Commutation monitoring	UINT16 0..1 0: monitoring with speed and position control active 1: monitoring inactive in all operating modes	0	R/W per.
Settings.IO_mode	29:31 (1D:1F _h)	4.1.4	Significance of I/O signal assignment	UINT16 0..2 0: settings of field bus parameter via I/O assignment 1: I/O freely available 2: I/O assigned with function	0	R/W per.

9.3.2 Parameter group "Commands"

Group.Name	Idx:Six dec (hex)	TLHMI	Explanation and unit []	Value range	Default value	R/W per.
Commands.eeprSave	11:6 (B:6 _h)	3.9 4.9 6.9	Back up parameter values in EEPROM memory 1: Save the range	UINT16 0..31 Ranges to be backed up: Bit0: parameter Bit1: data sets Bit2: list data list 1 Bit3: list data list 2 Bit4: User-defined data	–	R/W-
Commands.stateSave	11:7 (B:7 _h)	–	Processing status of "Com- mands.eeprSave"	UINT16 0: Save active 1: Save terminated	–	R/- -
Commands.default	11:8 (B:8 _h)	5.2 9.1	Initialise parameter with default values, factory setting	UINT16 1..2 1..initialise only controller para- meters 2: Run factory setting	–	R/W-
Commands.stateDef	11:9 (B:9 _h)	–	Processing status param. "Commands.default"	UINT16 0: Initialising active 1: Initialisation terminated	–	R/- -
Commands.driveCtrl	28:1 (1C:1 _h)	-	Control word for status change Write access triggers proces- sing of the status machine	UINT16 0...15 Bit 0: Disable power amplifier Bit 1: Enable power amplifier Bit 2: Stop (QuickStop) Bit 3: FaultReset Bit 4: QuickstopRelease (TLC units only, internal acces- ses only) Bit 5: StopMotion (TLC units only) Bit 6...15: not assigned	0	R/W -
Commands.SetCtrl	28:4 (1C:4 _h)	5.1.0	Switching control parameter sets	UINT16 0..2 0: - 1: parameter set 1 2: parameter set 2	0	R/W-
Commands.OnlAuto	29:30 (1D:1E _h)	-	Access to the mode setting	UINT16 0..65535 0: access via all access chan- nels 1: access only via the channel that set this parameter	0	R/W-
Commands.del_err	32:2 (20:2 _h)	5.4	Deletion of all entries in error memory	UINT16 0..1	0	R/W-

9.3.3 Parameter group "PA"

Max. current: Smaller value of "servomotor.I_maxM" and "PA.I_maxPA"

Group.Name	Idx:Six dec (hex)	TLHMI	Explanation and unit []	Value range	Default value	R/W per.
PA.KPid	12:4 (C:4 _h)	–	Current controller longitudinal direction (d) P factor (10=1V/A)	UINT16	–	R/– per.
PA.KIid	12:5 (C:5 _h)	–	Current controller longitudinal direction (d) I factor [100=1ms]	UINT16 13..32767	500	R/W per.
PA.KPiq	12:8 (C:8 _h)	–	Current controller transverse direction (q) P factor [10=V/Apk]	UINT16	100	R/– per.
PA.KIiq	12:9 (C:9 _h)	–	Current controller transverse direction (q) I factor [100=1ms]	UINT16 13..32767	500	R/– per.
PA.I_maxfw	12:18 (C:12 _h)	–	Field-weakening controller, max. field current [100=1Apk]	UINT16 0..32767	300	R/W per.
PA.KPfw	12:19 (C:13 _h)	–	Field-weakening controller P-factor [1000=1Apk/V]	UINT16 1..32767	300	R/W per.
PA.Kifw	12:20 (C:14 _h)	–	Field-weakening controller reset time (100 = 1ms)	UINT16 26..32767	500	R/W per.
PA.Serial	16:2 (10:2 _h)	–	Module serial number	UINT32 0..4294967295	–	R/W per.
PA.I_maxPA	16:8 (10:8 _h)	2.2.1	Peak current of the unit [100=1Apk]	UINT16 1..32767	1000	R/W per.
PA.I_nomPA	16:9 (10:9 _h)	2.2.2	Rated current of the unit [100=1Apk]	UINT16 1..32767	300	R/W per.
PA.T_warnPA	16:10 (10:A _h)	2.2.15	Temperature warning threshold of the current amplifier [K]	UINT16 1..512	353	R/W per.
PA.T_maxPA	16:11 (10:B _h)	2.2.16	Max. permitted temperature of the current amplifier [K]	UINT16 1..512	358	R/W per.
PA.U_maxDC	16:12 (10:C _h)	2.2.17	Max. permitted DC bus voltage on the DC-bus [10=1V]	UINT16 1..20000	4000	R/W per.
PA.I2tPA	16:13 (10:D _h)	2.2.10	Max. permitted time for max. current at high speed [ms]	UINT16 1..32767	3000	R/W per.
PA.I2t_warnB	16:14 (10:E _h)	2.2.12	Warning threshold for make time of internal ballast resistor [ms]	UINT16 1..32767	10	R/W per.
PA.I2tB	16:15 (10:F _h)	2.2.11	Max. permitted make time of internal ballast resistor [ms]	UINT16 1..32767	11	R/W per.
PA.F_maxChop	16:16 (10:10 _h)	2.2.18	Permitted switching frequency of the current amplifier	UINT16 0: 4 kHz 1: 8 kHz 2: 16 kHz,	1	R/W per.
PA.U_BalOn	16:20 (10:14 _h)	2.2.20	Switch on DC bus voltage for ballast	UINT16 1..20000	4300	R/W per.
PA.U_minDC	16:21 (10:15 _h)	2.2.19	DC bus undervoltage for switching off the drive	UINT16 1..20000	1500	R/W per.
PA.U_BalOff	16:46 (10:2E _h)	2.2.21	Ballast switch-off voltage [should be lower than the switch-on threshold (hysteresis)]	UINT16 1..32767	4100	R/W per.

Group.Name	Idx:Six dec (hex)	TLHMI	Explanation and unit []	Value range	Default value	R/W per.
PA.I2t_n0PA	16:47 (10:2F _h)	2.2.13	Max. permitted time for max. current at low speed [ms]	UINT16 1..32767	400	R/W per.
PA.P_maxB	16:49 (10:31 _h)	–	Internal ballast rated current [W]	UINT16 1..32767	30	R/W per.
PA.I_maxPAr	16:52 (10:34 _h)	2.2.3	Reduced peak current of the unit [100=1Apk]	UINT16 1..32767	1000	R/W per.
PA.I_nomPAr	16:53 (10:35 _h)	2.2.4	Reduced nominal current of the unit [100=1Apk]	UINT16 1..32767	300	R/W per.
PA.P_maxBusr	16:57 (10:39 _h)	4.1.40	Maximum permissible ballast power [W] Note: This parameter is only visible with the IP54 controller.	UINT16 TLCx32: 25 - 170 W TLCx34: 37 - 255 W	25 37	R/W per.

9.3.4 Parameter group "Servomotor"

Max. current: Smaller value of "servomotor.I_maxM" and "PA.I_maxPA"

Group.Name	Idx:Six dec (hex)	TLHMI	Explanation and unit []	Value range	Default value	R/W per.
Servomotor.principIM	13:1 (D:1 _h)	–	Motor type	UINT16 0xA1: Stepper motor 0xA2: Synchronous servomotor 0xA3: Asynchronous motor	0	R/W per.
Servomotor.infoM	13:3 (D:3 _h)	–	Motor calibration carried out	UINT16 0..65535	–	R/W per.
Servomotor.adj1Sen	13:4 (D:4 _h)	–	1. Alignment information of the position sensor (eps_e_b)	UINT16 0..65535 calibration value Sincoder/ resolver alignment offset = "eps_e_b"	–	R/W per.
Servomotor.adj2Sen	13:5 (D:5 _h)	–	2. Alignment information of the position sensor	UINT16 0..65535	0	R/W per.
Servomotor.reserve	13:6 (D:6 _h)	–	Position offset low word	UINT16 0..65535	–	R/W per.
Servomotor.reserve	13:7 (D:7 _h)	–	Position offset high word	UINT16 0..65535	–	R/W per.
Servomotor.TypeM	13:8 (D:8 _h)	2.1.1	Motor type, sequential number	INT32 0: No motor selected -...: Resolver motors +...: Sincoder motors - 2147483648..2147483648	0	R/W per.

Group.Name	Idx:Six dec (hex)	TLHMI	Explanation and unit []	Value range	Default value	R/W per.
Servomotor.SensorM	13:9 (D:9 _h)	2.1.5	Motor encoder type	UINT16 0..6 0: unknown 1: Resolver 2: SNS (Sincoder) 3: SRS (SinCos Singleturn 1024 lines) 4: SRM (SinCos Multiturn 1024 lines) 5: SRS (SinCos Singleturn 512 lines) 6: SRM (SinCos multiturn 512 lines)	0	R/W per.
Servomotor.Count-Sen	13:10 (D:A _h)	–	Line number of position sensor per motor revolution	UINT16 0..5	1	R/W per.
Servomotor.n_maxM	13:11 (D:B _h)	2.1.9	Maximum permissible motor speed [rpm]	UINT16 0 .. 13200	3000	R/W per.
Servomotor.n_nomM	13:12 (D:C _h)	2.1.14	Nominal motor speed [rpm]	UINT16 0 .. 12000	3000	R/W per.
Servomotor.I_maxM	13:13 (D:D _h)	2.1.8	Max. motor current [100=1A _{pk}]	UINT16 0..32767	1000	R/W per.
Servomotor.I_nomM	13:14 (D:E _h)	2.1.10	Nominal motor current [100=1A _{pk}]	UINT16 0..32767	100	R/W per.
Servomotor.M_nomM	13:15 (D:F _h)	2.1.15	Nominal torque [Ncm]	UINT16 0..32767	100	R/W per.
Servomotor.M_maxM	13:16 (D:10 _h)	2.1.16	Peak torque [Ncm]	UINT16 0..32767	200	R/W per.
Servomotor.U_nomM	13:17 (D:11 _h)	2.1.17	Nominal motor voltage [10=1V]	UINT16 0..32767	6000	R/W per.
Servomotor.Pole-pairM	13:18 (D:12 _h)	2.1.25	Motor pole-pair number	UINT16 1..100	4	R/W per.
Servomotor.KeM	13:20 (D:14 _h)	2.1.26	Motor EMF constant Ke [100=1Vs]	UINT16 1..10000	1000	R/W per.
Servomotor.JM	13:21 (D:15 _h)	2.1.27	Motor mass moment of inertia [10=1 kgmm ²]	UINT16 0..32767	30	R/W per.
Servomotor.R_UVM	13:22 (D:16 _h)	2.1.28	Motor terminating resistor (100=1 Ohm)	UINT16 1..10000	100	R/W per.
Servomotor.L_qM	13:23 (D:17 _h)	2.1.35	Motor inductance q-direction [100=1 mH]	UINT16 1..10000	50	R/W per.
Servomotor.L_dM	13:24 (D:18 _h)	2.1.36	Motor inductance d-direction [100=1 mH]	UINT16 1..10000	50	R/W per.
Servomotor.T_maxM	13:26 (D:1A _h)	2.1.30	Max. motor temperature [K]	UINT16 0..512	393	R/W per.
Servomotor.I2tM	13:27 (D:1B _h)	2.1.37	I2t motor: max. permissible time with max. current "Servomotor.I_maxM" [ms]	UINT16 0..32767	3000	R/W per.
Servomotor.fR	13:28 (D:1C _h)	2.1.21	Resolver frequency	UINT16 0: 3.5 kHz 1: 5 kHz 2: 6.5 kHz 3: 10 kHz 0..3	1	R/W per.

Group.Name	Idx:Six dec (hex)	TLHMI	Explanation and unit []	Value range	Default value	R/W per.
Servomotor.Pole-pairR	13:29 (D:1D _h)	2.1.20	Pole-pair number of resolver	UUINT16 1..10	1	R/W per.
Servomotor.TempTypeM	13:30 (D:1E _h)	2.1.38	Temperature sensor type (PTC / NTC)	UUINT16 0: PTC 1: NTC	0	R/W per.
Servomotor.T_warnM	13:32 (D:20 _h)	2.1.29	Motor temperature early warning [K]	UUINT16 1..32767	353	R/W per.
Servomotor.Tcal_t1	13:33 (D:21 _h)	–	Temperature characteristic 1, value 1	UUINT16 0..32767	1	R/W per.
Servomotor.Tcal_t2	13:34 (D:22 _h)	–	Temperature characteristic 1, value 2	UUINT16 0..32767	2	R/W per.
Servomotor.Tcal_t3	13:35 (D:23 _h)	–	Temperature characteristic 1, value 3	UUINT16 0..32767	3	R/W per.
Servomotor.Tcal_t4	13:36 (D:24 _h)	–	Temperature characteristic 1, value 4	UUINT16 0..32767	4	R/W per.
Servomotor.Tcal_t5	13:37 (D:25 _h)	–	Temperature characteristic 1, value 5	UUINT16 0..32767	5	R/W per.
Servomotor.Tcal_t6	13:38 (D:26 _h)	–	Temperature characteristic 1, value 6	UUINT16 0..32767	6	R/W per.
Servomotor.Tcal_t7	13:39 (D:27 _h)	–	Temperature characteristic 1, value 7	UUINT16 0..32767	7	R/W per.
Servomotor.Tcal_t8	13:40 (D:28 _h)	–	Temperature characteristic 1, value 8	UUINT16 0..32767	8	R/W per.
Servomotor.Tcal_u1	13:41 (D:29 _h)	–	Temperature characteristic 2, value 1	UUINT16 0..32767	1	R/W per.
Servomotor.Tcal_u2	13:42 (D:2A _h)	–	Temperature characteristic 2, value 2	UUINT16 0..32767	2	R/W per.
Servomotor.Tcal_u3	13:43 (D:2B _h)	–	Temperature characteristic 2, value 3	UUINT16 0..32767	3	R/W per.
Servomotor.Tcal_u4	13:44 (D:2C _h)	–	Temperature characteristic 2, value 4	UUINT16 0..32767	4	R/W per.
Servomotor.Tcal_u5	13:45 (D:2D _h)	–	Temperature characteristic 2, value 5	UUINT16 0..32767	5	R/W per.
Servomotor.Tcal_u6	13:46 (D:2E _h)	–	Temperature characteristic 2, value 6	UUINT16 0..32767	6	R/W per.
Servomotor.Tcal_u7	13:47 (D:2F _h)	–	Temperature characteristic 2, value 7	UUINT16 0..32767	7	R/W per.
Servomotor.Tcal_u8	13:48 (D:30 _h)	–	Temperature characteristic 2, value 8	UUINT16 0..32767	8	R/W per.
Servomotor.ResolutM	13:49 (D:31 _h)	2.1.6	Resolution of the position sensor [inc/rev.]	UUINT32 0..32768	16384	R/W per.
Servomotor.name1M	13:50 (D:32 _h)	–	Motor name, 1. Part	UUINT32 0..4294967295	0	R/W per.
Servomotor.name2M	13:51 (D:33 _h)	–	Motor name, 2. Part	UUINT32 0..4294967295	0	R/W per.
Servomotor.name3M	13:52 (D:34 _h)	–	Motor name, 3. Part	UUINT32 0..4294967295	0	R/W per.
Servomotor.name4M	13:53 (D:35 _h)	–	Motor name, 4. Part	UUINT32 0..4294967295	0	R/W per.

Group.Name	Idx:Six dec (hex)	TLHMI	Explanation and unit []	Value range	Default value	R/W per.
Servomotor.l_0M	13:54 (D:36 _h)	2.1.13	Motor continuous current at standstill (100=1Apk)	UINT16 1..32767	100	R/W per.

9.3.5 Parameter group "CtrlBlock1..CtrlBlock2"

CtrlBlock1: Index 18

CtrlBlock2: Index 19

Max. current: Smaller value of "servomotor.l_maxM" and "PA.l_maxPA"

Group.Name	Idx:Six dec (hex)	TLHMI	Explanation and unit []	Value range	Default value	R/W per.
CtrlBlock1.l_max	18:2 (12:2 _h)	4.2.2	Current limitation in all operating modes including controller optimisation. Not in manual and Quick-Stop operating modes (100=1Apk)	UINT16 0..max. Current 0..29999	1000	R/W per.
CtrlBlock1.n_max	18:5 (12:5 _h)	4.2.3	Max. speed [rpm]	UINT16 0..'Servomotor.n_maxM' 0..13200	6000	R/W per.
CtrlBlock1.KPn	18:7 (12:7 _h)	4.2.5 6.2.1	Speed controller P-factor [10000=1A*min/rev]	UINT16 0..32767	10	R/W per.
CtrlBlock1.TNn	18:8 (12:8 _h)	4.2.6 6.2.2	Speed controller correction time I-factor (100=1ms)	UINT16 26..32767	500	R/W per.
CtrlBlock1.TVn	18:9 (12:9 _h)	4.2.7 6.2.3	Speed controller rate time D-factor (100=1ms)	UINT16 0..32767	0	R/W per.
CtrlBlock1.KFPn	18:10 (12:A _h)	4.2.15 6.2.4	Speed controller pilot control P-factor (100=1 mA*min/rev)	UINT16 0..32767	0	R/W per.
CtrlBlock1.KFDn	18:11 (12:B _h)	4.2.16 6.2.5	Speed controller pilot control D-factor (10,000=1 mAs*min/U)	UINT16 0..4998	0	R/W per.
CtrlBlock1.K1n	18:12 (12:C _h)	-	Speed controller pilot control actual speed [100=1 mA*min/rev]	UINT16 0..32767	0	R/W per.
CtrlBlock1.KPp	18:15 (12:F _h)	4.2.10 6.3.1	Position controller P-factor [10=1/s]	UINT16 0..32767	14	R/W per.
CtrlBlock1.TVp	18:16 (12:10 _h)	4.2.11 6.3.2	Position controller derivative time D-factor (100=1ms)	UINT16 0..32767	0	R/W per.
CtrlBlock1.KFPp	18:18 (12:12 _h)	4.2.17 6.3.3	Position controller feed pilot control speed	UINT16 0..32767	100	R/W per.
CtrlBlock1.KFAp	18:19 (12:13 _h)	4.2.18 6.3.4	Speed controller feed forward control acceleration (10 000=1 mAs*min/rev)	UINT16 0..32767	0	R/W per.
CtrlBlock1.Filt_nRef	18:20 (12:14 _h)	4.2.8	Filter time constant reference variable filter of the setpoint speed (100=1ms)	UINT16 0..32767	0	R/W per.
CtrlBlock1.KFAp2	18:25 (12:19 _h)	-	Speed controller feed forward control acceleration [As*min/rev]	UINT16 0..32767	0	R/W per.

9.3.6 Parameter group "Motion"

Group.Name	Idx:Six dec (hex)	TLHMI	Explanation and unit []	Value range	Default value	R/W per.
Motion.Filt_jerk	28:5 (1C:5 _h)	4.4.26	Jerk filter	UINT16 0..30 0: from 3..30: filter setting value	0	R/W per.
Motion.invertDir	28:6 (1C:6 _h)	4.4.27	Inversion of sense of rotation	UINT16 0..2 0: no inversion 1: direction inversion function Mode1: after controller startup the current encoder value is inverted 2: direction inversion function Mode2: after controller startup the current encoder value is not inverted (only motors with Multiturn rotary encoder)	0	R/W per.
Motion.SW_LimP	29:4 (1D:4 _h)	4.4.5	Software limit switch for pos. position limit LIMP Condition: SW_LimP > SW_LimN [usr]	INT32 -2147483648 ..2147483647	2147483647	R/W per.
Motion.SW_LimN	29:5 (1D:5 _h)	4.4.6	Software limit switch for pos. position limit LIMN Condition: SW_LimN < SW_LimP [usr]	INT32 -2147483648 ..2147483647	-2147483647	R/W per.
Motion.SW_Enabl	29:6 (1D:6 _h)	4.4.7	Set monitoring of software limit switch 0: disabled 1: enabled	UINT16 0..96 Bit5: SW_LIMP Bit6: SW_LIMN	0	R/W per.
Motion.pNormNum	29:7 (1D:7 _h)	4.4.20	Position calibration numerator	INT32 -2147483648 ..2147483647	1	R/W per.
Motion.pNormDen	29:8 (1D:8 _h)	-	Position calibration denominator	INT32 -2147483648 ..2147483647	16384	R/W per.
Motion.vNormNum	29:9 (1D:9 _h)	4.4.21	Speed calibration numerator	INT32 1 ..2147483647	1	R/W per.
Motion.vNormDen	29:10 (1D:A _h)	-	Speed calibration denominator	INT32 1 ..2147483647	1	R/W per.
Motion.aNormNum	29:11 (1D:B _h)	4.4.22	Acceleration calibration numerator	INT32 1..2147483647	1	R/W per.
Motion.aNormDen	29:12 (1D:C _h)	-	Acceleration calibration denominator	INT32 1..2147483647	1	R/W per.
Motion.n_max0	29:21 (1D:15 _h)	4.4.28	Speed limit for travel profile [rpm]	UINT32 1.. 'Servomotor.n_maxM' 1..12000	3000	R/W per.
Motion.v_target0	29:23 (1D:17 _h)	4.4.11	Setpoint speed [usr]	UINT32 1..n_max0 1..2147483647	60	R/W per.
Motion.acc_type	29:25 (1D:19 _h)	4.4.13	Shape of acceleration curve	UINT16 1..2 1: Linear 2: -	1	R/W per.

Group.Name	Idx:Six dec (hex)	TLHMI	Explanation and unit []	Value range	Default value	R/W per.
Motion.acc	29:26 (1D:1Ah _h)	4.4.14	Acceleration [usr]	UINT32 1.. 2 147 483 647	600	R/W per.
Motion.dec	29:27 (1D:1B _h)	4.4.15	Deceleration [usr]	UINT32 1.. 2 147 483 647	600	R/W per.

9.3.7 Parameter group "Manual"

Max. current: Smaller value of "servomotor.l_maxM" and "PA.l_maxPA"

Max. speed: Value limited by unit of "servomotor.n_maxM"

Group.Name	Idx:Six dec (hex)	TLHMI	Explanation and unit []	Value range	Default value	R/W per.
Manual.l_maxMan	28:25 (1C:19 _h)	3.2.14	Max. current manual movement [100=1Apk]	UINT16 0..Max.current 0..29999	1000	R/W per.
Manual.startMan	41:1 (29:1 _h)	3.2.1	Start of manual movement with transfer of control bits	UINT16 0..7 Bit2: 0: slow 1: fast Bit1: neg. direction of rotation Bit0: pos. sense of rotation	–	R/W-
Manual.statusMan	41:2 (29:2 _h)	–	Acknowledgement: Manual movement	UINT16 0..65535 Bit0: error LIMP Bit1: error LIMN Bit2: error HW_STOP Bit3: error REF Bit 5: error SW_LIMP Bit 6: error SW_LIMN Bit 7: error SW_STOP Bit14: manu_end Bit15: manu_err	–	R/- -
Manual.typeMan	41:3 (29:3 _h)	3.2.2	Type of manual movement	UINT16 0..1 0: classical inching 1: united inching	0	R/W per.
Manual.n_slowMan	41:4 (29:4 _h)	3.2.3	Speed for slow manual movement [usr]	UINT32 1..2147483647	60	R/W per.
Manual.n_fastMan	41:5 (29:5 _h)	3.2.4	Speed for fast manual movement [usr]	UINT32 1..2147483647	180	R/W per.
Manual.dist_Man	41:6 (29:6 _h)	3.2.5	Inch travel, defined travel per jog cycle with united inching [usr]	UINT16 1..65535	20	R/W per.
Manual.step_Man	41:7 (29:7 _h)	3.2.6	Inch travel, defined travel on manual movement start [usr]	UINT16 0..65535 0: Continuous operation	20	R/W per.
Manual.time_Man	41:8 (29:8 _h)	3.2.7	Classical waiting time [ms]	UINT16 1..30000	500	R/W per.

9.3.8 Parameter group "VEL"

Group.Name	Idx:Six dec (hex)	TLHMI	Explanation and unit []	Value range	Default value	R/W per.
VEL.velocity	36:1 (24:1 _h)	3.1.2.1	Start of speed change with transfer of setpoint speed [usr]	INT32 -2147483648 ..2147483647	–	R/W-
VEL.stateVEL	36:2 (24:2 _h)	–	Acknowledgement: Speed profile mode	UINT16 0..65535 Bit0: error LIMP Bit1: error LIMN Bit2: error HW_STOP Bit3: error REF Bit5: error SW_LIMP Bit6: error SW_LIMN Bit7: error SW_STOP Bit13: Setpoint speed reached Bit14: vel_end Bit15: vel_err	–	R/- -

9.3.9 Parameter group "PTP"

Group.Name	Idx:Six dec (hex)	TLHMI	Explanation and unit []	Value range	Default value	R/W per.
PTP.p_absPTP	35:1 (23:1 _h)	3.1.1.1	Start of absolute positioning with transfer of absolute target position value [usr]	INT32 -2147483648..2147483647	–	R/W-
PTP.statePTP	35:2 (23:2 _h)	3.2.14	Acknowledgement: PTP positioning	UINT16 0..65535 Bit0: error LIMP Bit1: error LIMN Bit2: error HW_STOP Bit3: error REF Bit5: error SW_LIMP Bit6: error SW_LIMN Bit7: error SW_STOP Bit13: setpoint position reached Bit14: motion_end Bit15: motion_err	–	R/- -
PTP.p_relPTP	35:3 (23:3 _h)	3.1.1.2	Start of relative positioning with transfer of the value for the distance [usr]	INT32 -2147483648..2147483647	0	R/W-
PTP.continue	35:4 (23:4 _h)	3.1.1.3	Continuation of interrupted positioning with transfer of any value	UINT16 0..65535 value is not relevant for positioning	–	R/W-
PTP.v_tarPTP	35:5 (23:5 _h)	3.1.1.5	Setpoint speed of PTP positioning [usr]	INT32 1..2147483647	Motion.v_target0	R/W-

9.3.10 Parameter group "Gear"

Group.Name	Idx:Six dec (hex)	TLHMI	Explanation and unit []	Value range	Default value	R/W per.
Gear.startGear	38:1 (26:1 _h)	3.1.3.1	Starting an electronic gear process with selection of the processing mode	UINT16 0..2 0: disabled 1: immediate synchronisation 2: Synchronisation with compensatory movement	–	R/W-
Gear.stateGear	38:2 (26:2 _h)	–	Acknowledgement: gear processing	UINT16 0..65535 Bit0: error LIMP Bit1: error LIMN Bit2: error HW_STOP Bit3: error REF Bit5: error SW_LIMP Bit6: error SW_LIMN Bit7: error SW_STOP Bit13: - Bit14: gear_end Bit15: gear_err	–	R/- -
Gear.numGear	38:7 (26:7 _h)	3.1.3.2	Gear factor numerator	INT32 -2147483648..2147483647	1	R/W-
Gear.denGear	38:8 (26:8 _h)	–	Gear factor denominator	INT32 1..2147483647	1	R/W-
Gear.DirEnGear	38:13 (26:D _h)	–	Enabling the motion direction When the direction is reversed the enabling direction is reversed	INT16 1..3 1: positive direction 2: negative direction 3: both directions	3	R/W per.
Gear.p_absOffs	39:1 (27:1 _h)	3.1.3.6	Start of absolute offset positioning with transfer of position	INT32 -2147483648..2147483647	0	R/W-
Gear.stateOffs	39:2 (27:2 _h)	–	Acknowledgement: Offset positioning	UINT16 0..65535 Bit0: error LIMP Bit1: error LIMN Bit2: error HW_STOP Bit3: error REF Bit5: error SW_LIMP Bit6: error SW_LIMN Bit7: error SW_STOP Bit13: offset setpoint position reached Bit14: offset_motion_end Bit15: offset_motion_err	–	R/- -
Gear.p_relOffs	39:3 (27:3 _h)	3.1.3.7	Start of relative offset positioning with transfer of travel value [inc]	INT32 -2147483648..2147483647	0	R/W-
Gear.n_tarOffs	39:5 (27:5 _h)	3.1.3.8	Setpoint speed of offset positioning [rpm]	INT32 1..12000	60	R/W-
Gear.phomeOffs	39:6 (27:6 _h)	3.1.3.9	Dimension setting in offset positioning [Inc]	INT32 -2147483648..2147483647	0	R/W-
Gear.accOffs	39:7 (27:7 _h)	3.1.3.10	Acceleration ramp for offset positioning [rev/(min*s)]	INT32 60..2000000	300	R/W-

Group.Name	Idx:Six dec (hex)	TLHMI	Explanation and unit []	Value range	Default value	R/W per.
Gear.decOffs	39:8 (27:8 _h)	3.1.3.11	Deceleration ramp for offset positioning [rev./((min*s)]	INT32 60..2000000	300	R/W-
Gear.ModeOffs	39:9 (27:9 _h)	3.1.3.12	Processing mode of an absolute or relative positioning	UINT16 0..1 0: jump 1: Profile	0	R/W per.

9.3.11 Parameter group "Home"

Group.Name	Idx:Six dec (hex)	TLHMI	Explanation and unit []	Value range	Default value	R/W per.
Home.startHome	40:1 (28:1 _h)	-	Start of referencing mode action object: A write access triggers a referencing	UINT16 1...8 1: LIMP 2: LIMN 3: REFZ neg. direction of rotation 4: REFZ pos. direction of rotation 5: LIMP with index pulse 6: LIMN with index pulse 7: REFZ neg. direction of rotation with index pulse 8: REFZ pos. direction of rotation with index pulse	-	R/W
Home.stateHome	40:2 (28:2 _h)	-	Acknowledgement: Referencing	UINT16 0..65535 Bit0: error LIMP Bit1: error LIMN Bit2: error HW_STOP Bit3: error REF Bit5: error SW_LIMP Bit6: error SW_LIMN Bit7: error SW_STOP Bit14: ref_end Bit15: ref_err	-	R/-
Home.startSetp	40:3 (28:3 _h)	3.3.2	Sizing on sizing position (set absolute position) [usr]	INT32 -2147483648..2147483647	-	R/W-
Home.v_Home	40:4 (28:4 _h)	3.3.3	Speed for search of reference switch [usr]	INT32 -2147483648..2147483647	60	R/W per.
Home.v_outHome	40:5 (28:5 _h)	3.3.4	Speed for processing withdrawal path and safety distance [usr]	INT32 -2147483648..2147483647	6	R/W per.
Home.p_outHome	40:6 (28:6 _h)	3.3.5	Max. withdrawal path with activated reference switch [usr]	UINT32 0..2147483647 0: withdrawal control disabled > 0: Withdrawal path [usr]	0	R/W per.
Home.p_disHome	40:7 (28:7 _h)	3.3.6	Safety distance from switching edge to reference point [usr]	UINT32 0..2147483647	200	R/W per.

Group.Name	Idx:Six dec (hex)	TLHMI	Explanation and unit []	Value range	Default value	R/W per.
Home.RefSwMod	40:9 (28:9 _h)	3.3.10	Processing sequence with reference movement to REF	UINT16 0..3 Bit0: direction reversal at REF 0: permissible (standard mode) 1: not permissible Bit1: direction of movement safety distance 0: away from switch 1: into switch area	0	R/W per.
Home.DefPosTyp	40:10 (28:A _h)	-	Reference position for processing safety distance and index pulse search	UINT16 0 .. 1 0 : setpoint position at standstill after deceleration as a result of signal change at limit or reference switch 1: Save current motor position on signal change at limit or reference switch	0	R/W per.
Home.RefAppPos	40:11 (28:B _h)	-	Application position at reference point [usr]	INT32 -2146483648.. +2146483647	0	R/W per.
Home.p_SrchIdx	40:12 (28:C _h)	-	Search range index pulse with position control at M1 This is only used with referencing at index pulse when the position control is installed at M1. [Inc]	INT32 1...2147483647	2147483647	R/W

9.3.12 Parameter group "CurrentControl"

Group.Name	Idx:Six dec (hex)	TLHMI	Explanation and unit []	Value range	Default value	R/W per.
CurrentControl.startCurr	50:1 (32:1 _h)	3.1.8.1	Starting current control	UINT16 0..2 0: disabled 1: setpoint value over +/-10V interface 2: Setpoint with parameter (CurrentControl.curr_targ)	-	R/W-

Group.Name	Idx:Six dec (hex)	TLHMI	Explanation and unit []	Value range	Default value	R/W per.
CurrentControl.stateCurr	50:2 (32:2 _h)	–	Acknowledgement: Current control mode.	UINT16 0..65535 Bit0: error LIMP Bit1: error LIMN Bit2: error HW_STOP Bit3: error REF Bit4: not assigned Bit5: SW_LIMP Bit6: SW_LIMN Bit7: SW_STOP Bit8-Bit12: not assigned Bit13: curr_ctrl_nact_zero 0: motor speed <> 0 1: motor speed = 0 Bit14: curr_ctrl_end 0: Process active 1: Process inactive Bit15: curr_ctrl_err 0: no error 1: Error	–	R/- -
CurrentControl.curr_targ	50:3 (32:3 _h)	3.1.8.2	Current setpoint for current control For control over field bus (=FB) this applies: (100 = 1Apk) For other control (≠FB) this applies: [Apk]	INT16 -32768..+32767 for other: -327.68..+327.67	0	R/W-

9.3.13 Parameter group "Oscillator"

Group.Name	Idx:Six dec (hex)	TLHMI	Explanation and unit []	Value range	Default value	R/W per.
Oscillator.startOszi	51:1 (33:1 _h)	3.1.9.1	Starting oscillator mode	UINT16 0..2 0: disabled (setpoint value=0) 1: Setpoint via ±10 V interface	0	R/W-

Group.Name	Idx:Six dec (hex)	TLHMI	Explanation and unit []	Value range	Default value	R/W per.
Oscillator.stateOszi	51:2 (33:2 _h)	-	Acknowledgement: Oscillator mode	UINT16 0..65535 Bit0: error LIMP Bit1:error LIMN Bit2: error HW_STOP Bit3: error REF Bit4: not assigned Bit5: error SW_LIMP Bit6: error SW_LIMN Bit7: error SW_STOP Bit8-Bit12: not assigned Bit13: setpoint speed reached 0: actual speed ¼ setpoint speed 1:actual speed = setpoint speed Bit14: oscillator_end 0: Process active 1: Process inactive Bit15: oscillator_err 0: no error 1: Error	-	R/- -
Oscillator.n_RefAna	51:3 (33:3 _h)	3.1.9.2	Setpoint speed at +10 V input signal [rpm]	UINT16 0 .. 13200 (note: max. motor speed must not be exceeded)	3000	R/W per.

9.3.14 Parameter group "Teach-In"

Group.Name	Idx:Six dec (hex)	TLHMI	Explanation and unit []	Value range	Default value	R/W per.
Teach.storeTeac	43:1 (2B:1 _h)	-	Teach-In-Bearbeitung, Speicherplatz auswählen Listennummer zur Ablage eines Positionswerts (0...63) Beispiel: 000010: Listennummer 2	UINT16 1..65535 Bit0..5: Listennummer	0	R/W -
Teach.stateTeac	43:2 (2B:2 _h)	-	Quittierung: Teach-In-Bearbeitung	UINT16 1..65535 Bit15: teach_err Bit14: teach_end	-	R/- -
Teach.memNrTeac	43:3 (2B:3 _h)	-	Datenspeicher für Teach-In-Bearbeitung	UINT16 1..2 1: Listendaten Liste 1 2: Listendaten Liste 2	1	R/W -
Teach.p_actTeac	43:4 (2B:4 _h)	-	Bei der Teach-In-Bearbeitung gespeicherte Motorposition [usr]	INT32 -2147483648..2147483647	-	R/- -

9.3.15 Parameter group "List"

Group.Name	Idx:Six dec (hex)	TLHMI	Explanation and unit []	Value range	Default value	R/W per.
List.startList	44:1 (2C:1 _h)	3.1.5.1 3.1.5.2 3.1.6.1 3.1.6.2	Activate new list control	UINT16 0..2 0 :no list active 1 : List 1 2 : List 2	0	R/W-
List.stateList	44:2 (2C:2 _h)	-	Acknowledgement and status: List control	UINT16 0..65535 Bit15: list_err Bit14: list_quit 0: list-controlled mode active 1: list-controlled mode completed Bit 0,1: - 0 : no list active - 1 : list 1 active - 2 : list 2 active	-	R/- -
List.typeList1	44:3 (2C:3 _h)	-	List 1: List type	UINT16 1: Pos./signal 2: Pos./speed	1	R/- -
List.cntList1	44:4 (2C:4 _h)	-	List 1: number of available list entries	UINT16 0..64	64	R/- -
List.bgnList1	44:6 (2C:6 _h)	-	List 1: starting number of the list control end number > = starting number	UINT16 0..63	0	R/W per.
List.endList1	44:7 (2C:7 _h)	-	List 1: end number of the list control end number > = starting number	UINT16 0..63	63	R/W per.
List.chgList1	44:9 (2C:9 _h)	-	List1: Change by other interfaces	UINT16 0..65535 0: no change <>0: Change	0	R/W-
List.typeList2	44:11 (2C:B _h)	-	List 2: List type	UINT16 1: Pos./signal 2: Pos./speed	1	R/- -
List.cntList2	44:12 (2C:C _h)	-	List 2: number of available list entries	UINT16 0..64	64	R/- -
List.bgnList2	44:14 (2C:E _h)	-	List 2: starting number of the list control end number > = starting number	UINT16 0..63	0	R/W per.
List.endList2	44:15 (2C:F _h)	-	List 2: end number of the list control end number > = starting number	UINT16 0..63	63	R/W per.
List.actList	44:18 (2C:12 _h)	-	List: activated processing number	INT16 -1..63 -1: still no list entry activated 0..63: last activated list entry range preset by start and end number of the list control	-1	R/- -

9.3.16 Parameter group "List1Data0..List1Data63"

L1Data0: Index 1100
 L1Data1: Index 1101
 L1Data63: Index 1163

Group.Name	Idx:Six dec (hex)	TLHMI	Explanation and unit []	Value range	Default value	R/W per.
L1Data0.typeList1	1100:1 (44C:1 _h)	7.3.1.1	List 1: list type for ALL following list entries (1101:x...1163:x)	UINT16 1..2 1: Pos./signal 2: Pos./speed	1	R/W per.
L1Data0.posList1	1100:2 (44C:1 _h)	7.3.2.1 7.3.2.2	List 1: Position [usr]	INT32 -2147483648..2147483647	0	R/W per.
L1Data0.signList1	1100:3 (44C:1 _h)	7.3.2.3	List 1: signal state	UINT16 0, 1	0	R/W per.
L1Data0.velList1	1100:4 (44C:1 _h)	7.3.2.4	List 1: setpoint speed [usr]	INT32 -2147483648..2147483647 -'Motion.n_max0' .. +'Motion.n_max0' setting depends on PTP operating mode : 0: PTP.Vtarget; <>0: Amount of the saved value VEL: 0: VEL.velocity; <>0: Amount of the saved value	0	R/W per.

9.3.17 Parameter group "List2Data0..List2Data63"

L2Data0: Index 1200
 L2Data1: Index 1201
 L2Data63: Index 1263

Group.Name	Idx:Six dec (hex)	TLHMI	Explanation and unit []	Value range	Default value	R/W per.
L2Data0.typeList2	1200:1 (4B0:1 _h)	7.4.1.1	List 2: list type for all following list entries (1201:x...1263:x)	UINT16 1..2 1: Pos./signal 2: Pos./speed	1	R/W per.
L2Data0.posList2	1200:2 (4B0:1 _h)	7.4.2.1 7.4.2.2	List 2: Position [usr]	INT32 -2147483648..2147483647	0	R/W per.
L2Data0.signList2	1200:3 (4B0:1 _h)	7.4.2.3	List 2: signal state	UINT16 0..1	0	R/W per.

Group.Name	Idx:Six dec (hex)	TLHMI	Explanation and unit []	Value range	Default value	R/W per.
L2Data0.velList2	1200:4 (4B0:1 _h)	7.4.2.4	List 2: setpoint speed [usr]	INT32 -2147483648..2147483647 -'motion.n_max0' .. .'Motion.n_max0' setting depends on PTP operating mode: 0: PTP.Vtarget; <>0: Amount of the saved value VEL: 0: VEL.velocity; <>0: Amount of the saved value	0	R/W per.

9.3.18 Parameter group "Capture"

Group.Name	Idx:Six dec (hex)	TLHMI	Explanation and unit []	Value range	Default value	R/W per.
Capture.TrigSign	20:13 (14:D _h)	-	Selection of trigger signals for saving the position Bit 3..2: signal - channel 2 (K2) Bit 1..0: signal - channel 1 (K1) examples: 4: binary 01 00 => CAPTURE2 (K2), CAPTURE1 (K1) 9: 10 01 => CAPTURE2 (K2), index p. setpoint pos. (K1)	UINT16 0..15 Bit 0..1/ Bit 2..3 (K1/K2): - 00: CAPTURE1 - 01: CAPTURE2 - 10: index pulse setpoint pos. sensor (with module at M1) - 11: index pulse actual pos. sensor (in SM with module at M2)	4	R/W-
Capture.TrigType	20:14 (14:E _h)	-	Position source for saving the position	UINT16 0..1 0: actual position encoder 1: setpoint position encoder	1	R/W-
Capture.TrigLevl	20:15 (14:F _h)	-	Signal level for trigger chan- nels Bit status: 0: triggering at 1->0 switch 1: triggering at 0->1 switch	UINT16 0..3 Bit 0: set trigger level at chan- nel 1 Bit 1: set trigger level on chan- nel 2	3	R/W-
Capture.TrigStart	20:16 (14:10 _h)	-	start triggering (bits0..1): 0: no change 1: reset triggers and restart interrupt triggers (Bit14=1) repeat triggers (Bit15) 0: trigger once 1: trigger continuously	UINT16 0..3 Bit 0: trigger at channel 1 Bit 1: trigger at channel 2 Bit 14: interrupt trigger Bit 15: Trig. repeat	0	R/W-
Capture.TrigStat	20:17 (14:11 _h)	-	Status, triggering executed	UINT16 0..3 Bit 0: triggering at channel 1 Bit 1: triggering on channel 2	0	R/- -
Capture.TrigPact1	20:18 (14:12 _h)	-	Actual position of motor on triggering on channel 1 [Incl]	INT32 -214748364..2147483647	-	R/- -
Capture.TrigPact2	20:19 (14:13 _h)	-	Actual position of motor on triggering on channel 2 [Incl]	INT32 -214748364..2147483647	-	R/- -

Group.Name	Idx:Six dec (hex)	TLHMI	Explanation and unit []	Value range	Default value	R/W per.
Capture.TrigPref1	20:20 (14:14 _h)	–	Setpoint of elect. gear on triggering on channel 1 [Inc]	INT32 -214748364..2147483647	–	R/- -
Capture.TrigPref2	20:21 (14:15 _h)	–	Setpoint of elect. gear on triggering on channel 2 [Inc]	INT32 -214748364..2147483647	–	R/- -

9.3.19 Parameter group "I/O"

Group.Name	Idx:Six dec (hex)	TLHMI	Explanation and unit []	Value range	Default value	R/W per.
I/O.IW0_act	33:1 (21:1 _h)	2.4.1	input word 0 The following applies for 'Forcen' (e.g. with TLCT): read access shows force state	UINT16 0..65535 Bit0: LIMP Bit1: LIMN Bit2: STOP Bit3: REF Bit12: - Bit13: – additional bits (independent of IO_ mode assignment) if analogue module IOM-C is installed Bit14: DIG_IN1 Bit15: DIG_IN2	–	R/- -
I/O.IW1_act	33:4 (21:4 _h)	2.4.2	input word 1 The following applies with 'Forcen' (e.g. with TLCT): read access shows force state	UINT16 0..65535 Bit0..Bit4: I_0..I_4 Bit5: CAPTURE1 Bit6: CAPTURE2 Bit7..Bit13: I_5..I_13 Bit14: DIG_IN1 Bit15: DIG_IN2 Settings.IO_mode'=0/1: - Bit0: BAUD_1/I_0 - Bit1: BAUD_2/I_1 - Bit2: BAUD_4/I_2 - Bit3: MODE_1/I_3 - Bit4: MODE_2/I_4 - Bit5: I_5/I_5 additional: CAPTURE1 - Bit6: I_6/I_6 additional: CAPTURE2 - Bit7: ADR_64/I_7 - Bit8: ADR_1/I_8 - Bit9: ADR_2/I_9 - Bit10: ADR_4/I_10 - Bit11: ADR_8/I_11 - Bit12: ADR_16/I_12 - Bit13: ADR_32/I_13 Additional bits if analogue module IOM-C is installed: - Bit14: DIG_IN1/DIG_IN1 - Bit15: DIG_IN2/DIG_IN2	–	R/- -

Group.Name	Idx:Six dec (hex)	TLHMI	Explanation and unit []	Value range	Default value	R/W per.
I/O.QW0	34:1 (22:1 _h)	2.4.10	output word 0 The following applies with 'Forcen' (e.g. with TLCT): read access shows force state	UINT16 0..65535 'Settings.IO_mode'=0/1: - Bit0: Q0/Q0 - Bit1: Q1/Q1 - Bit2: Q2/Q2 - Bit3: Q3/Q3 - Bit4: Q4/Q4 - Bit5: ACTIVE_CON/ ACTIVE_CON - Bit6: TRIGGER/TRIGGER - Bit 7..Bit13: not assigned Additional bits if analogue module IOM-C is installed: - Bit14: DIG_OUT1/DIG_OUT1 - Bit15: DIG_OUT2/DIG_OUT2	-	R/W -
I/O.OutTrig	34:9 (22:9 _h)	-	Setting trigger output when signal list inactive	UINT16 0..1 0: Low level 1: High level	0	R/W-

9.3.20 Parameter group "M1"

Max. current: Smaller value of "servomotor.l_maxM" and "PA.l_maxPA"

Group.Name	Idx:Six dec (hex)	TLHMI	Explanation and unit []	Value range	Default value	R/W per.
M1.RS422-C	21:9 (15:9 _h)	4.5.6	Resolution of the incremental encoder at module M1 [inc]	UINT16 100 .. 65535	16384	R/W per.
M1.PULSE-C	21:10 (15:A _h)	4.5.1	Setting position encoder PULSE-C	0..10 UINT16 Bit 2: max. frequency 0: 200 kHz, 1: 25 kHz Bit 3: Signal form: 0: PULSE-DIR 1: PV-PR	0	R/W per.
M1.AnalogIn2	21:14 (15:E _h)	2.3.3.5	voltage value analogue input 2 [mV]	INT16 -10000.. +10000	-	R/- -
M1.AnalogIn3	21:19 (15:13 _h)	2.3.3.6	voltage value analogue input 3 [mV]	INT16 -10000.. +10000	-	R/- -
M1.AnalogO1	21:24 (15:18 _h)	2.3.3.7	Analogue output 1 [mV] (1000=1V) - voltage value from object default - voltage value for current set-point	INT16 -10000 ... +10000	0	R/W-
M1.Fkt_AOut1	21:25 (15:19 _h)	4.5.36	Function Speed setpoint value at analogue output 1	INT16 0..1 0: freely available (TLCT commissioning) 1: Function Current setpoint value output	0	R/W per.

Group.Name	Idx:Six dec (hex)	TLHMI	Explanation and unit []	Value range	Default value	R/W per.
M1.AOut1IScl	21:26 (15:1A _h)	4.5.37	+10V output signal with specified setpoint current The following applies for control by field bus (=FB): (100 = 1A) The following applies for control otherwise (≠FB): [A]	INT16 0.. max. current for FB: 0..32767 for other: 0..327.67	300	R/W per.
M1.AnalogO2	21:27 (15:1B _h)	2.3.3.8	Analogue output 2 [mV] (1000=1V) - voltage value from object default - voltage value for setpoint speed value	INT16 -10000.. +10000	0	R/W-
M1.Fkt_AOut2	21:28 (15:1C _h)	4.5.39	Function Speed setpoint value at analogue output 2	INT16 0..1 0: freely available (TLCT commissioning) 1: Function Speed setpoint output	0	R/W per.
M1.AOut2NScl	21:29 (15:1D _h)	4.5.40	+10V output signal with given speed [rpm]	INT16 0..14400 0 .. Max. speed = unit limits value of "Servomotor.N_maxM"	10000	R/W per.
M1.rs422dir	21:38 (15:26 _h)	-	Inverting the M1 encoder signal for position control at M1	UINT16 0..1 0 = do not invert 1 = invert	0	R/W per.
M1.m1m2pdlim	21:39 (15:27 _h)	-	Following error limit value for higher-order following error monitoring between M1 and M2	UINT16 1..32000	1000	R/W per.
M1.filterval	21:40 (15:28 _h)	-	Filter value for calculation of M1 encoder speed 0: not active >0: active, value corresponds to T _n [ms] (corresponds to the time constant of the PT1 link) resolution: +/- 31 Inc./s In CAM mode the filter must not be disabled!	UINT16 1..32000	10	R/W per.
M1.M1_EncMod	28:27 (1C:1B _h)	4.1.15	Selection Position controller for actual position value	UINT16 0 .. 1 0 : position control by the encoder integrated in the motor 1: Position control with module M1	0	R/W per.

9.3.21 Parameter group "M2"

Group.Name	Idx:Six dec (hex)	TLHMI	Explanation and unit []	Value range	Default value	R/W per.
M2.RS422Inc	22:10 (16:A _h)	4.5.3	Setting position encoder RS422IN-C	UINT16 1: A/B quadruple evaluation	1	R/- per.
M2.SetEncPos	22:14 (16:E _h)	-	Setting absolute position in position encoder [Inc]	UINT32 -2147483648..+2147483647 SRS, Sincos-Singleturn: 0 .. 16383 SRM, Sincos.Multiturn: 0 .. 67108863 (=4096*16384-1)	-	R/W per.

9.3.22 Parameter group "M3"

Group.Name	Idx:Six dec (hex)	TLHMI	Explanation and unit []	Value range	Default value	R/W per.
M3.EsimResol	23:22 (17:16 _h)	-	Encoder simulation: Setting the resolution [Inc/rev]	UINT 16 0...5 Setting resolution: Stepper motor / AC servo 0: 4000 / 4096 1: 2000 / 2048 2: 1000 / 1024 3: 500 / 512 4: 250 / 256 5: 125 / 128	0	R/W per.

9.3.23 Parameter group "M4"

Group.Name	Idx:Six dec (hex)	TLHMI	Explanation and unit []	Value range	Default value	R/W per.
M4.profilSer	24:11 (18:B _h)	4.5.10	RS485 interface, processing mode incl. profile selection Only readable by field bus	UINT32 0..4294967295	0	R/W per.
M4.baudSer	24:12 (18:C _h)	4.5.11	RS485 interface, baud rate [Baud] Only readable via field bus	UINT32 0..38400 0 = autobaud 9600 = 9600 baud 19200 = 19200 baud 38400 = 38400 baud	9600	R/W per.
M4.addrSer	24:13 (18:D _h)	4.5.12	RS485 interface, address Only readable via field bus	UINT16 1..31	1	R/W per.
M4.toutSer	24:14 (18:E _h)	4.5.13	RS485 interface, monitoring time for a timeout message [ms] Only readable via field bus	UINT16 0..65535 0: Monitoring disabled	0	R/W-
M4.profillbs	24:16 (18:10 _h)	4.5.15	Interbus-S, processing mode incl. profile selection Only readable by field bus	UINT32 0..4294967295	0	R/W per.
M4.baudlbs	24:17 (18:11 _h)	4.5.16	Interbus-S, baud rate [kbaud] Only readable via field bus	UINT32 500000..2000000	500000	R/W per.

Group.Name	Idx:Six dec (hex)	TLHMI	Explanation and unit []	Value range	Default value	R/W per.
M4.toutlbs	24:18 (18:12 _h)	4.5.17	Interbus-S, timeout period [ms] Only readable via field bus	UINT16 0..640 0: Monitoring disabled	640	R/W per.
M4.profilPbd	24:20 (18:14 _h)	4.5.20	Profibus-DP, processing mode incl. profile selection Only readable via field bus	UINT32 0..429496795	0	R/W per.
M4.addrPbd	24:21 (18:15 _h)	4.5.21	Profibus-DP, address Only readable via field bus	UINT16 0..126	126	R/W per.
M4.profilCan	24:23 (18:17 _h)	4.5.25	CAN-C, processing mode incl. profile selection Only readable via field bus	UINT32 0..2 0: CAN bus 1: CanOpen 2: DeviceNet	0	R/W per.
M4.addrCan	24:24 (18:18 _h)	4.5.26	CAN-C, address Only readable via field bus	UINT16 0..127	127	R/W per.
M4.baudCan	24:25 (18:19 _h)	4.5.27	CAN-C, baud rate [baud] Only readable via field bus	UINT32 20000..1000000	125k	R/W per.
M4.toutCan	24:26 (18:1A _h)	4.5.28	CAN-C, timeout time [ms]	UINT16 0..65535 0: Monitoring disabled	0	R/W per.
M4.busRxD	24:28 (18:1C _h)	2.6.1	Received data online com- mand processing (Byte 1 ... 4)	UINT32 0.. 4294967295	0	R/- -
M4.busRxD5_8	24:29 (18:1D _h)	2.6.1	Received data online com- mand processing (Byte 5 ... 8)	UINT32 0.. 4294967295	0	R/- -
M4.busDiag	24:30 (18:1E _h)	2.6.5	Bus diagnosis for DeviceNet (DNSTATE)	UINT16 0..65535 0: OFFLINE 1: ONLINE 2: LINK_OK 3: FAILURE 4: TIMED_OUT 5: IDLE 0..65535	-	R/- -
M4.busTout	24:31 (18:1F _h)	2.6.6	Bus statistics timeout: Total number of broken con- nections caused by timeout (node guarding)	UINT16 0 .. 65535	0	R/W-
M4.busError	24:32 (18:20 _h)	2.6.7	Bus statistics transmission error: total of all errors that resulted in a connection break	UINT16 0 .. 65535	0	R/W-
M4.busTxD	24:33 (18:21 _h)	2.6.2	Transmission data online com- mand processing (Byte 1 ... 4)	UINT32 0.. 4294967295	0	R/- -
M4.busTxD5_8	24:34 (18:22 _h)	2.6.2	Transmission data online com- mand processing (Byte 5 ... 8)	UINT32 0.. 4294967295	0	R/- -
M4.busCycle	24:35 (18:23 _h)	2.6.6	Bus statistics bus cycles: Total number of all processed bus cycles	UINT32 0.. 4294967295	0	R/W-

9.3.24 Parameter group "Status"

Group.Name	Idx:Six dec (hex)	TLHMI	Explanation and unit []	Value range	Default value	R/W per.
Status.serial_no	1:20 (1:14 _h)	2.8.5	Unit serial number, max 9-characters	UINT32 0..4294967295	0	R/W per.
Status.p_DifPeak	12:16 (C:10 _h)	2.3.1.9	Max. achieved following errors [Inc] write access resets value	UINT32 0..131072	0	R/W-
Status.AnalogIn	20:8 (14:8 _h)	2.3.3.1	analogue input at input ANALOG_IN [mV]	INT16 -10000..+10000	0	R/- -

Group.Name	Idx:Six dec (hex)	TLHMI	Explanation and unit []	Value range	Default value	R/W per.
Status.driveStat	28:2 (1C:2 _h)	2.3.5.1	Status word for the operating status	UINT32 0..429496795 Bit0..3: Current operating status: - 1: Start - 2: Not Ready to switch on - 3: Switch on disabled - 4: Ready to switch on - 5: Switched on - 6: Operation enable - 7: Quick-Stop active - 8: Fault response enabled - 9: Fault Bit4: reserved Bit5=1: error internal monitoring (FltSig) Bit6=1: error external monitoring (FltSig_SR) Bit7=1: warning message Bit8..11: not assigned Bit12..15: operating-mode-specific coding of the processing status Bit13: x_add_info Bit14: x_end Bit15: x_err Bit16-20: current operating mode (corresponds to Bit0-4: Status.xmode_act) 0: not used 1: manual positioning mode 2: referencing 3: PTP positioning 4: speed profile 5: electronic gear with offset adjustment, position-controlled (AC) or with position reference (SM) 6: electronic gear speed-controlled 7: data set mode 8: function generator (current controller) 9: function generator (speed controller) 10: function generator (position controller) 11..15: cannot be set 16: function generator in status disabled 17: current regulation 18: oscillator mode 19: cam profile CAM 20..30: reserved 31: do not use Bit21: drive is referenced (ref_ok) Bit22: control deviation in position window (SM not assigned)	-	R/- -

Group.Name	Idx:Six dec (hex)	TLHMI	Explanation and unit []	Value range	Default value	R/W per.
Status.xMode_act	28:3 (1C:3 _h)	2.3.5.5	Current axis mode with additional information, Bit0..4: For a list of possible operating modes for your TL unit see Chapter 'Operating modes'	UINT16 0..65535 Bit0..4: Current operating mode (device-specific) [For a list of possible operating modes for your TL device see Chapter "Operating modes"] 0: not used 1: manual positioning mode 2: referencing 3: PTP positioning 4: speed profile 5: electronic gear with offset adjustment, position-controlled (AC) or with position reference (SM) 6: electronic gear speed-controlled 7: data set mode 8: function generator (current controller) 9: function generator (speed controller) 10: function generator (position controller) 11..15: cannot be set 16: function generator in status disabled 17: current regulation 18: oscillator mode 19..30: reserved 31: do not use Bit5: drive is referenced ('ref_OK') Bit6: control deviation inside position window (SM: not assigned) Bit7: reserved Bit8..15: not assigned	-	R/- -
Status.Sign_SR	28:15 (1C:F _h)	2.3.4.1	Saved signal states of external monitoring signals 0: not active, 1: enabled	UINT16 0..15 Bit 0 : LIMP Bit 1: LIMN Bit 2: STOP Bit 3: REF	-	R/- -

Group.Name	Idx:Six dec (hex)	TLHMI	Explanation and unit []	Value range	Default value	R/W per.
Status.FltSig	28:17 (1C:11 _h)	2.3.4.3	monitoring signals 0: not active, 1: enabled	0..429496795 UINT32 Bit0: error power up Bit1: DC bus undervoltage Lim1 Bit2: DC undervoltage Lim2 Bit3: motor line earth fault Bit4: motor line short circuit Bit5: DC bus overvoltage Bit6: overtemperature ballast Bit7: overtemp. motor Bit8: overtemp. power amplifier Bit9: I2t power amplifier Bit10: reserved Bit11: I2t motor Bit12: I2t ballast Bit13: phase monitoring motor Bit14: phase monitoring net- work Bit15: watchdog Bit16: internal system error Bit17: pulse lock/SAM error Bit18: TLHMI protocol error Bit19: max. speed exceeded Bit20: guidance sensor cable break Bit21: actual position encoder cable break Bit22: Position Deviation Error Bit23: Line fail 24V Bit24: following error Bit25: short circuit of digital outputs Bit26: incorrect limit switch Bit27: early warning motor temperature Bit28: temperature early warning power amplifier Bit29: Bit30: SAM warning Bit31: not assigned	–	R/- -

Group.Name	Idx:Six dec (hex)	TLHMI	Explanation and unit []	Value range	Default value	R/W per.
Status.FltSig_SR	28:18 (1C:12 _h)	2.3.4.4	Saved monitoring signals	UINT32 0..419496795 Bit0: error power up Bit1: DC bus undervoltage Lim1 Bit2: DC undervoltage Lim2 Bit3: motor line earth fault Bit4: motor line short circuit Bit5: DC bus overvoltage Bit6: overtemperature ballast Bit7: overtemp. motor Bit8: overtemp. power amplifier Bit9: I2t power amplifier Bit10: reserved Bit11: I2t motor Bit12: I2t ballast Bit13: phase monitoring motor Bit14: - Bit15: watchdog Bit16: internal system error Bit17: pulse block Bit18: TLHMI protocol error Bit19: max. speed exceeded Bit20: guidance sensor cable break Bit21: actual position encoder cable break Bit22: Position Deviation Error Bit23: Line fail 24V Bit24: following error Bit25: short circuit of digital outputs Bit26: incorrect limit switch Bit27: early warning motor temperature Bit28: early warning tempera- ture power amplifier Bit29: Bit30: Bit31:	-	R/- -
Status.action_st	28:19 (1C:13 _h)	2.3.4.8	Action word, saved error classes Bits	UINT32 0..65535 Bit0: error class 0 Bit1: error class 1 Bit2: error class 2 Bit3: error class 3 Bit4: error class 4 Bit5: reserved Bit6: actual speed = 0 Bit7: pos. direction of rotation drive Bit8: neg. direction of rotation drive Bit8: current limiting active Bit10: speed limit active Bit11: guidance = 0 Bit12: drive decelerates Bit13: drive accelerates Bit14: Drive operates constant	1	R/- -

Group.Name	Idx:Six dec (hex)	TLHMI	Explanation and unit []	Value range	Default value	R/W per.
Status.IntSigSr	29:34 (1D:22 _h)	2.3.4.2	Monitoring signals controller 0: not enabled, 1: enabled	UINT32 0..4294967295 Bit0..1: reserved Bit2: position overrun Bit3..4: reserved Bit5: SW limit switch, pos. direction of rotation (SW_LIMP) Bit 6: SW limit switch, neg. direction of rotation (SW_LIMN) Bit7: stop via control word (SWSTOP) Bit8..14: reserved Bit15: power amplifier not active Bit16..31: reserved	–	R/- -
Status.ActCtrl	31:4 (1F:4 _h)	2.3.5.3	Active controller parameter set	UINT16 0..2 0: reserved 1: parameter set 1 active 2: parameter set 2 active	–	R/- -
Status.p_ref	31:5 (1F:5 _h)	2.3.1.2	Setpoint position of rotor [inc]	INT32 -2147483648..+2147483647	–	R/- -
Status.p_act	31:6 (1F:6 _h)	2.3.1.1	Motor position / rev. [inc]	INT32 -2147483648..+2147483647	–	R/- -
Status.p_dif	31:7 (1F:7 _h)	2.3.1.10	Following error [Inc]	INT32 -2147483648..+2147483647	–	R/- -
Status.n_ref	31:8 (1F:8 _h)	2.3.2.2	Setpoint speed [rpm]	INT16 -32768..32767	–	R/- -
Status.n_act	31:9 (1F:9 _h)	2.3.2.1	Actual speed [rpm]	INT16 -32768..32767	–	R/- -
Status.l_ref	31:10 (1F:A _h)	2.3.3.11	Setpoint current [100=1A]	INT16 -32768..32767	–	R/- -
Status.ld_ref	31:11 (1F:B _h)	–	Setpoint current d-component [100=1A]	INT16 -32768..32767	–	R/- -
Status.l_act	31:12 (1F:C _h)	2.3.3.10	current motor current [100=1A]	INT16 -32768..32767	–	R/- -
Status.ld_Act	31:13 (1F:D _h)	–	Current motor current d-component [100=1A]	INT16 -32768..32767	–	R/- -
Status.uq_ref	31:14 (1F:E _h)	–	Setpoint voltage q-component [10=1V]	INT16 -32768..32767	–	R/- -
Status.ud_ref	31:15 (1F:F _h)	–	Setpoint voltage d-component [10=1V]	INT16 -32768..32767	–	R/- -
Status.p_abs	31:16 (1F:10 _h)	2.3.1.11	Absolute position per motor revolution (modulo value) [inc]	UINT16 0..32767 RESO-C: 0..4095 HIFA-C: 0..16383	–	R/- -
Status.l2tM_act	31:17 (1F:11 _h)	2.3.7.1	l2t total motor	INT16 0..100	–	R/- -
Status.l2tPA_act	31:18 (1F:12 _h)	2.3.7.2	l2t total power amplifier	INT16 0..100	–	R/- -
Status.l2tB_act	31:19 (1F:13 _h)	2.3.7.3	l2t total ballast	INT16 0..100	–	R/- -

Group.Name	Idx:Six dec (hex)	TLHMI	Explanation and unit []	Value range	Default value	R/W per.
Status.UDC_act	31:20 (1F:14 _h)	2.3.3.2	DC bus voltage [10=1V]	INT16 0..32767	-	R/- -
Status.lu_act	31:21 (1F:15 _h)	-	Motor phase current phase U [100=1A]	INT16 -32768..32767	-	R/- -
Status.lv_act	31:22 (1F:16 _h)	-	Motor phase current phase V [100=1A]	INT16 -32768..32767	-	R/- -
Status.TM_act	31:24 (1F:18 _h)	2.3.6.1	Temperature of motor [°C] When using motors with PTC temperature sensors the object does not return valid values.	INT16 0..200	-	R/- -
Status.TPA_act	31:25 (1F:19 _h)	2.3.6.2	Temperature of power amplifier [°C]	INT16 35..100	-	R/- -
Status.p_refGear	31:26 (1F:1A _h)	2.3.1.6	Setpoint position of electronic gear [inc]	INT32 -2147483648..2147483647	-	R/- -
Status.v_refGear	31:27 (1F:1B _h)	2.3.2.5	Setpoint speed of electronic gear [Inc]	INT32 -2147483648..2147483647	-	R/- -
Status.v_ref	31:28 (1F:1C _h)	-	Speed of the rotor position setpoint value p_ref [inc/s]	INT32 -2147483648..2147483647	-	R/- -
Status.acc_ref	31:29 (1F:1D _h)	2.3.2.10	Acceleration of the position controller setpoint p_ref [rpm*s]	UINT16 1..1000	-	R/- -
Status.p_target	31:30 (1F:1E _h)	2.3.1.5	Target position of travel profile generator [usr]	INT32 -2147483648..2147483647	-	R/- -
Status.p_jerkusr	31:31 (1F:1F _h)	2.3.1.4	Actual position of movement profile generator [usr]	INT32 -2147483648..2147483647	-	R/- -
Status.p_tarOffs	31:32 (1F:20 _h)	2.3.1.8	Target position of offset positioning in electronic gear [inc]	INT32 -2147483648..2147483647	-	R/- -
Status.p_refOffs	31:33 (1F:21 _h)	2.3.1.7	Actual position of offset positioning in electronic gear [inc]	INT32 -2147483648..2147483647	-	R/- -
Status.p_actusr	31:34 (1F:22 _h)	2.3.1.3	Actual position of motor in user-defined units [usr]	INT32 -2147483648..2147483647	-	R/- -
Status.v_jerkusr	31:35 (1F:23 _h)	2.3.2.3	Actual speed of movement profile generator [usr]	INT32 -2147483648..2147483647	-	R/- -
Status.n_refOffs	31:36 (1F:24 _h)	2.3.2.6	Actual speed of offset positioning in electronic gear [rpm]	INT32 -2147483648..2147483647	-	R/- -
Status.p_remaind	31:37 (1F:25 _h)	-	Residual value of position calibration of position setpoint p_ref [Inc]	INT32 -2147483648..2147483647	-	R/- -
Status.v_target	31:38 (1F:26 _h)	2.3.2.4	Target speed of movement profile generator	INT32 -2147483648..2147483647	-	R/- -
Status.p_jerk	31:40 (1F:28 _h)	-	Setpoint position at jerk filter input [Inc]	INT32 -2147483648..2147483647	-	R/- -
Status.v_jerk	31:41 (1F:29 _h)	-	Setpoint speed at jerk filter input [Inc]	INT32 -2147483648..2147483647	-	R/- -
Status.p_addGear	31:42 (1F:2A _h)	2.3.1.15	Checksum output position electronic gear [Inc]	INT32 -2147483648..2147483647	-	R/- -

Group.Name	Idx:Six dec (hex)	TLHMI	Explanation and unit []	Value range	Default value	R/W per.
Status.v_refM1	31:43 (1F:2B _h)	2.3.2.5	Speed from input value increments counted on module on M1 [Inc/s]	INT32 -2147483648..2147483647	–	R/- -
Status.p_refusr	31:44 (1F:2C _h)	–	Setpoint position of rotor position [usr]	INT32 -2147483648..2147483647	–	R/- -
Status.v_refusr	31:45 (1F:2D _h)	–	Speed of rotor position setpoint p_ref [usr]	INT32 -2147483648..2147483647	–	R/- -
Status.p_diffind	31:48 (1F:30 _h)	–	Distance between switch and index pulse after reference movement [Inc]	INT32 -2147483648.. 2147483647	–	R/- -
Status.p_absall	31:49 (1F:31 _h)	Zero	Modulo position based on work range actual position	UINT32 0..2147483647 With Multiturn encoders: 4096 U * 16384 Inc 0 .. 67 108 863 Position control must not be enabled on M1!	Zero	R/- -
Status.p_refM1	31:50 (1F:32 _h)	–	Encoder position of module M1 position non-linearised value: counted increments of the module M1 [increments]	-2147483648 .. 2147483647	–	R/- -
Status.PDIFM1M2	31:51 (1F:33 _h)	–	Read value, current following error between the M1 and M2 encoders corresponding to the resolution at the M1 encoder [inc] Can only be set with position control at the M1 encoder.	INT16	–	R/- -
Status.StopFault	32:7 (20:7 _h)	2.5.1	Cause of last interruption, error number	UINT16 1..65535	–	R/- -

9.3.25 Parameter group "ErrMem0"

ErrMem0: Index 900
ErrMem1: Index 901
ErrMem19: Index 919

Group.Name	Idx:Six dec (hex)	TLHMI	Explanation and unit []	Value range	Default value	R/W per.
ErrMem0.ErrNum	900:1 (384:1 _h)	2.5.2	Coded error number	UINT16 0..65535	–	R/- -
ErrMem0.Class	900:2 (384:2 _h)	–	Error class	UINT16 0..65535	–	R/- -
ErrMem0.Time	900:3 (384:3 _h)	–	Error time since power amplifier switched on [s]	UINT32 0..4294967295	–	R/- -
ErrMem0.AmpOn-Cnt	900:4 (384:4 _h)	–	number of power amplifier switch-on cycles	UINT32 0..4294967295	–	R/- -
ErrMem0.ErrQual	900:5 (384:5 _h)	–	Additional information for assessing error	UINT32 0..4294967295	–	R/- -

10 Accessories and spare parts

Item	Designation	IP20/IP54	Order no.
-	Print documentation for TLC53x controller, German	X / X	0098 441 113 110
-	Print documentation for TLHMI hand-held operating unit, multilingual	X / X	0098 441 113 091
-	Print documentation for TLCT commissioning software, German	X / X	0098 441 113 095
-	Online documentation for controller on CD-ROM, multilingual	X / X	0098 441 113 138
1	TLCT commissioning software with online documentation on CD-ROM, multi-lingual	X / X	0062 501 101 803
2	TLHMI hand-held operating unit with print documentation	X / X	0062 501 101 503
-	SK14 shielding terminal	X / X	0062 501 101 400
-	connector set for complete assembly	X / X	0062 501 519 002
3	Motor cable 1.5 mm ² with motor plug Motor cable 2.5 mm ² with motor plug Motor cable 4 mm ² with motor plug	X / X	0062 501 322 xxx 0062 501 319 xxx 0062 501 320 xxx
-	Cables for ballast resistor controller 2.5 mm ² Cable for ballast resistor controller 4 mm ²	X / -	0062 501 444 yyy 0062 501 445 yyy
4	Sensor cable for RESO-C resolver module or HIFA-C Hiperface module	X / X	0062 501 439 xxx
5	Pulse-direction cable for PULSE-C module Encoder cable for RS442-C module, open at one end Cable for IOM-C module	X / X	0062 501 447 yyy 0062 501 449 yyy 0062 501 452 xxx
6	Encoder cable for RS422-C module, with plug at both ends Encoder cable for ESIM3-C module	X / X	0062 501 448 yyy 0062 501 448 yyy
7	Field-bus cable for CAN-C module Field-bus cable for IBS-C module Field-bus cable for RS485-C module	X / X	0062 501 446 yyy 0062 501 451 yyy 0062 501 455 xxx
-	Module cable for connection of SAM module and SAM adapter	X / X	0062 501 454 yyy
-	CAN terminal plug, 9-pin Socket CAN terminal plug, 9-pin Plug	X / X	0062 501 518 002 0062 501 518 003
8	RS232 programming cable 5 m RS232 programming cable 10 m	X / X	0062 501 441 050 0062 501 441 100
9	TLHBC holding brake controller	X / -	0062 501 101 606
10	Ballast resistor controller TLBRC	X / -	0062 501 101 706
11	External ballast resistor BWG 250072 + angle W110 (100W, 72 ohm) External ballast resistor BWG 250150 + angle W110 (100W, 150 ohm) External ballast resistor BWG 500072 + angle W216 (200W, 72 ohm) External ballast resistor BWG 500150 + angle W216 (200W, 150 ohm)	X / -	0059 060 100 001 0059 060 100 002 0059 060 100 003 0059 060 100 004
12	terminal angle TS 15 e.g. for terminals from PhoenixContact, Type MBK	- / X	0062 501 102 200
13	Set of grommets type KDT/Z ¹⁾ (see supplier)	- / X	0062 501 102 202
-	Fan kit to increase ballast power	- / X	0062 501 102 204

1) The inside diameter of the grommets must match the diameter of the cable used.

xxx: 003 = 3 m, 005 = 5 m, 010 = 10 m, 020 = 20 m
yyy: 005 = 0,5 m, 015 = 1,5 m, 030 = 3 m, 050 = 5m
Longer cables on request

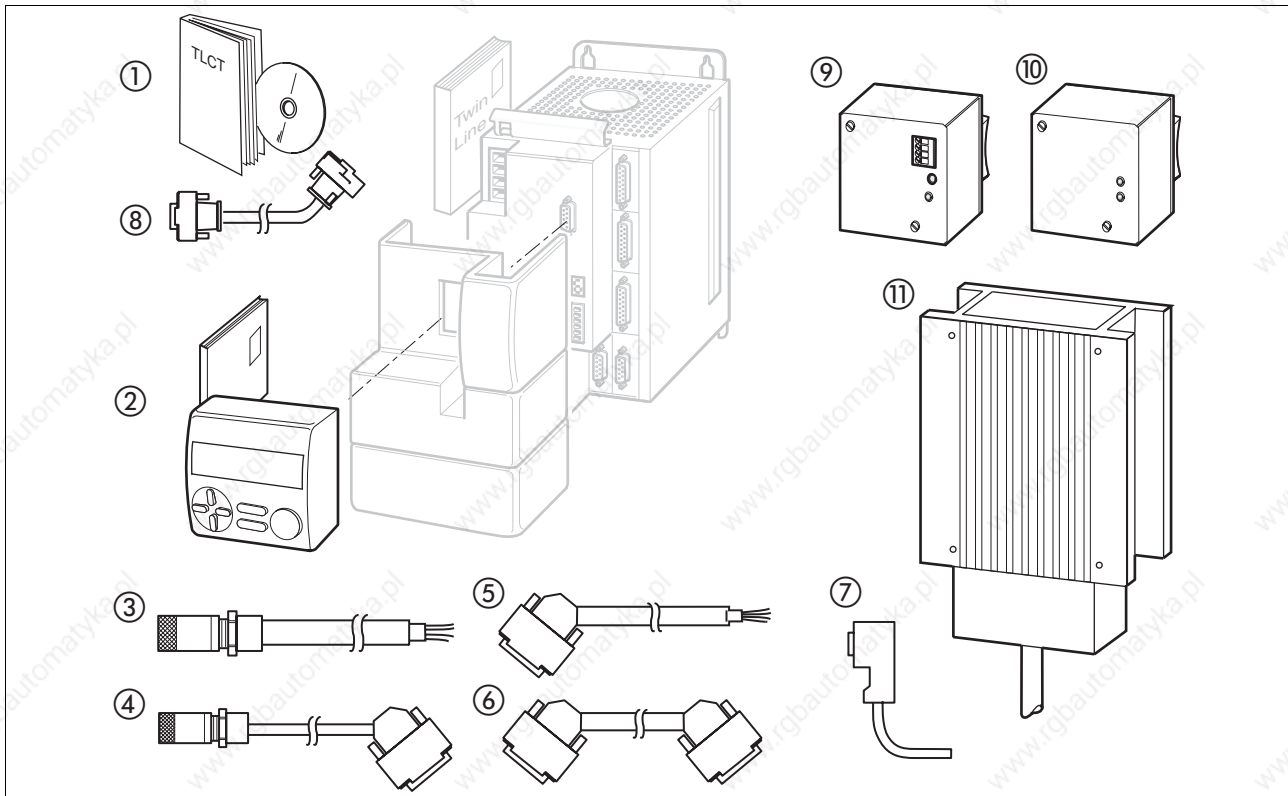

Figure 10.1 Accessories for IP20 controller

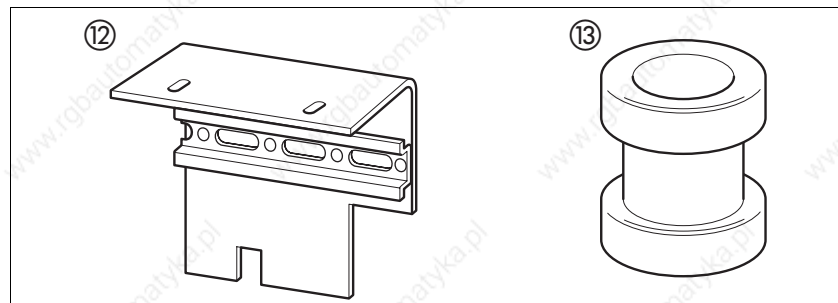

Figure 10.2 Special accessories for IP54 controller

Suppliers

Grommets:

Murrplastic GmbH
 D-71567 Oppenweiler
 Tel.: +49 (0) 7191 / 482-0
 Fax.: +49 (0) 7191 /482-280

11 Service, maintenance and disposal



DANGER!

Electric shock, fire or explosion

- Only qualified personnel who are familiar with and understand the contents of this manual and the other relevant manuals are authorised to work on and with this drive system.
- Before working on the drive system:
 - Switch off power to all terminals.
 - Place a sign "DO NOT SWITCH ON" on the switch and lock to prevent switching on.
 - **Wait 6 minutes** (for discharge of DC bus capacitors).
 - Measure voltage between DC+ and DC- and check for <48V. (The DC bus LED is not a safe indication for absence of the DC bus voltage).
- Do not short-circuit DC bus or touch unshielded components or screws of the terminals with voltage present.
- Install all covers and close the housing doors before applying power.
- The motor generates voltage when the shaft is rotated. Lock the shaft of the motor to prevent rotation before starting work on the drive system.
- The system manufacturer is responsible for compliance with all applicable regulations relevant to earthing the drive system.
- Do not reach into the drive system (e.g. no pointed objects).



WARNING!

Unexpected responses may cause injury and damage to the system.

The behaviour of the drive system is governed by numerous saved data. Unsuitable data may cause unexpected motions or responses to signals.

- Do not operate a unit with unknown data.
- Check the saved data.
- When commissioning carefully run tests for all operating states and fault cases.
- Check the functions after replacing a unit and also after changes to the saved data.
- Start the system only if there are no persons or materials in the danger zone and the system can be operated safely.

11.1 Service address



If you have any questions please contact your local dealer. Your dealer will be happy to give you the name of a customer service outlet in your area.

Warranty

The seal confirms that no unauthorised person has opened the unit.



The number of the seal identifies the tester and is not necessarily that shown above.

Have any repairs to our drive systems conducted only by a repair service that we have certified. Do not make any mechanical or electrical modifications to the drive components. We will not honour the warranty or accept any liability if unauthorised modifications are made or the system is opened.

Repairs cannot be made with the device installed.



Before all work on the drive system consult the chapters on Installation and Commissioning to see what precautions and processes must be observed.

Maintenance

The controller is maintenance-free

- ▶ Check the filter in the switch cabinet ventilator regularly. Inspection intervals depend on the ambient conditions on site.

11.2 Shipping, storage, disposal

Removal

- ▶ Save the parameter settings of the controller:

The commissioning software can be used to back up all values to the PC data medium with "File - Save".

Use the TLHMI hand-held operating unit to import a parameter set to the copy memory of the TLHMI hand-held operating unit with the menu "8.1 Read Param"

- ▶ Switch off the controller.
- ▶ Disconnect the power supply.
- ▶ Label all connections on the controller.
- ▶ Disconnect the motor cable.
- ▶ Pull out the interface connector.
- ▶ Remove the controller from the switch cabinet.

Shipping The controller must be protected against shocks during transport. Use the original packaging for this purpose.

Storage Store the controller only under the specified, permissible environmental conditions for room temperature and humidity.

Protect the controller against dust and dirt.

Disposal The controller consists of various materials that can be recycled or must be disposed of separately.

Remove the following parts from the controller for recycling

- Housing, screws and terminals for ferrous metal recycling
- Cables for copper recycling
- Connectors, hood for plastics recycling

Circuit boards and electronic components must be disposed of separately in accordance with the applicable environmental protection laws. Send these parts for special waste disposal.

12 Glossaries

12.1 Terms and Abbreviations

<i>AC</i>	Alternating Current
<i>Actual position</i>	Current absolute or relative position of moving components in the drive system.
<i>Address</i>	Memory location which can be accessed by its unique number. See also Slave address.
<i>Angular position of the motor</i>	The angular position of the motor corresponds to the angular position of the rotor in the motor housing and refers to the zero point or index point of the position sensor.
<i>API</i>	Application Program Interface
<i>ASCII</i>	American Standard Code for Information Interchange; Standard for coding text characters
<i>Asynchronous error</i>	Error detected and reported by the internal controller monitoring equipment.
<i>Blocking detection</i>	The blocking detection monitors the max. current, the period and the rotation of the motor shaft. A standstill of the motor shaft in spite of max. current for an adjusted time will result in a blocking error.
<i>Calibration factors</i>	Factors for describing and modifying user-defined units with reference to a motor revolution.
<i>CAN</i>	(C ontroller A rea N etwork), standardized open Fieldbus over which the drives and other devices from different manufacturers communicate with one another.
<i>CANopen</i>	Device and manufacturer-independent description language for communication in the CAN bus
<i>Control dynamics</i>	Speed with which a controller responds to a disturbance or a change in the input signal.
<i>CRC</i>	Cyclical Redundancy Check, error checking
<i>Data frame</i>	Serially transmitted data packet with unique start and end identification. The structure depends on the protocol in use.
<i>DC</i>	Direct current
<i>DC bus</i>	Electric circuit that generates the direct current required to operate the motor and supplies the required energy to the power amplifier. The DC bus acts as a buffer for energy fed back by the motor.
<i>Default values</i>	Preset values for the parameters before initial commissioning, factory settings.
<i>Degree of protection</i>	The degree of protection is a standardised specification for electrical equipment that describes the protection against the entry of foreign bodies and water (for example, IP20)
<i>DiCoder</i>	digital encoder from the Stegmann company, digital sensor system for position capture

<i>Direction of rotation</i>	Rotation of the motor shaft in a clockwise or counterclockwise direction. A clockwise direction of rotation is given when the motor shaft rotates clockwise as the observer faces the end of the protruding shaft. This is the positive direction of rotation.
<i>Drive solution</i>	The drive solution consists of the drive system and the mechanical system components permanently installed in the motion chain.
<i>Drive system</i>	The drive system consists of the controller including power amplifier and motor.
<i>E</i>	Encoder
<i>EC</i>	European Community
<i>Electronic gear</i>	An input speed is recalculated by the drive system using the values of an adjustable gear factor to derive a new output speed for the motor movement.
<i>EMC</i>	Electromagnetic compatibility
<i>Encoder</i>	Sensor for recording the angular position of a rotating element. The encoder is mounted on the motor and signals the angular position of the rotor.
<i>Error class</i>	Classification of possible operating faults of the drive system that result in an error status.
<i>EU</i>	European Union
<i>FI</i>	Fault current
<i>Fieldbus</i>	A bus optimised for data transmission between field devices. A Fieldbus is "open", meaning that it is not proprietary (not supported by only one manufacturer). The parameter settings of the drive system can be called and modified via the Fieldbus, inputs can be monitored and outputs controlled and diagnosis and error monitoring functions enabled.
<i>Forcing</i>	To change signal states regardless of the hardware switching status in the unit; with the commissioning software, for example. The hardware signals remain unchanged.
<i>GSD file</i>	The specific characteristics of a Profibus device type are described in the device master data file (GSD file). This file is supplied with the device by the manufacturer, and must be read by the network configuration program..
<i>Half duplex</i>	Bidirectional data transmission in which only one user can transmit at any time.
<i>Holding brake</i>	brake that only prevents the motor from rotating without power after it has stopped (e.g. a Z-axis lowering). It must not be used as a service brake for braking motion.
<i>\hat{I}^2t-monitoring</i>	Predictive temperature monitoring. The expected temperature rise of unit components is calculated in advance on the basis of the motor current. If a limit value is exceeded, the drive system reduces the motor current.
<i>I/O</i>	Inputs/Outputs
<i>Idx</i>	Index value of a parameter
<i>Inc</i>	Increment

<i>Incremental encoder</i>	Encoder which sends the position changes in the form of two signals at 90°.
<i>Incremental signals</i>	Angular steps of an encoder in the form of square-wave pulse sequences. Relative changes in position are signalled by the number of pulses contained in the pulse sequence.
<i>Index pulse</i>	Encoder signal for referencing the rotor position in the motor. The encoder sends one index pulse per revolution.
<i>Inhibit time</i>	A PDO can be assigned a minimum waiting time for repeat transmissions in order to relieve the data transfer volume on the field bus. After the first transmission, the PDO is not re-sent until the delay has expired.
<i>Input device</i>	A device that can be connected to the RS232 interface for commissioning, either the HMI handheld operating unit or a PC with the commissioning software..
<i>Internal units</i>	Resolution of the power amplifier with which the motor is directed to the new setpoint. Internal units are given in increments.
<i>IT system</i>	Power system with no earth potential reference, since it is not earthed. I: Isolation Isolation: T: terre (French): Earth
<i>Limit switch</i>	Switch that signals an overrun of the permissible travel range.
<i>LED</i>	Light-Emitting Diode
<i>LRC</i>	Longitudinal Redundancy Check, error checking
<i>LWL</i>	Optic fiber
<i>M</i>	Motor
<i>Master</i>	Active bus user that controls the data traffic in the network.
<i>Module code</i>	Internal electronic code (8 bit) which describes the hardware and the functionality of modules. This code is stored in an EEPROM in every module.
<i>Multiturn</i>	sensor system for position capture of the SinCos type; after start-up it measures an absolute value within 4096 revolutions and continues to count incrementally from this point
<i>Node-Guarding</i>	Monitoring function with slave at an interface for cyclic communication.
<i>node ID</i>	Node address assigned to a device on the network.
<i>NTC</i>	resistance with negative temperature coefficient. Resistance value is reduced as the temperature rises.
<i>Optically isolated</i>	Electrical transmission of signals with electrical isolation
<i>Parameter</i>	Device functions and values that can be set and called by the user.
<i>PC</i>	Personal Computer
<i>PELV</i>	Protective Extra Low Voltage, functional low voltage with safe isolation
<i>PDO</i>	Process Data Object
<i>per.</i>	Information on whether the value of the parameter is non-volatile, i.e. is retained in memory after switching the unit off. The user must back up the data in the non-volatile memory before switching off the device to ensure that the value is saved in non-volatile memory.
<i>PKE</i>	Parameter code

<i>PLC</i>	Programmable Logic Controller
<i>PNO</i>	Profibus User Organisation
<i>Power amplifier</i>	A device that generates current for controlling the motor in accordance with the positioning signals from the controller.
<i>Power circuit</i>	See Power amplifier
<i>Profibus</i>	Standardised open field bus compliant with EN 50254-2 over which drives and other devices from different manufacturers communicate with one another.
<i>Protocol</i>	Guideline that specifies the format required for transmitting data.
<i>PTC</i>	resistance with positive temperature coefficient. Resistance value is increased as the temperature rises.
<i>Pulse direction signals</i>	Digital signals with variable pulse frequencies which signal changes in position and rotation direction via separate signal wires.
<i>PWE</i>	Parameter value
<i>PWM</i>	Pulse Width Modulation
<i>PZD</i>	Process data
<i>Quick-Stop</i>	This function is used in the event of faults, the STOP command or for fast braking of the motor.
<i>R/W</i>	Note on reading and writing the values "R/-" values are read-only "R/W" values are read and write.
<i>R_PDO</i>	Receive PDO
<i>Register</i>	Memory range of specified size (generally 8, 16 or 32 bits) for temporary storage of data transmitted from one system unit to another.
<i>Resolver</i>	Analogue encoder for determining the angular position of the rotor. It is used for returning the actual position of the motor for phase-accurate control of the motor.
<i>RS232 interface</i>	The RS232 port is the communications interface of the Twin Line unit for connecting a PC or the TLHMI hand-held operating unit.
<i>RS485</i>	Field bus interface compliant with EIA-485, which enables serial data transmission with multiple devices.
<i>RTU</i>	Remote Terminal Unit
<i>SDO</i>	Service Data Object
<i>Sense regulation</i>	The voltage drop on the power lines is compensated so the output voltage on the sense terminals has the correct voltage value. The output voltage is only enabled when the sense lines are connected.
<i>Sincoder</i>	An encoder for registering the position of the servomotor rotor as an analogue sine-cosine signal and as digital position data over the HIFAC module. The motor data that are read into the unit after switching on the Twin Line unit are saved in the Sincoder.
<i>SinCos®</i>	sensor system from the Stegmann company for position capture with an analogue sine/cosine signal; starts with absolute value and continues to count incrementally from that value.

<i>Singleturn</i>	sensor system for position capture of the SinCos type; after start-up it measures an absolute value within one revolution and continues to count incrementally from this point.
<i>Six</i>	Subindex value of a parameter
<i>Slave address</i>	Direct communication between master and slave devices is only possible after assignment of addresses.
<i>Slave</i>	Passive bus user that receives control commands and sends data to the master.
<i>SMART</i>	Operating system software of the controller
<i>Synchronous error</i>	Error reported by the controller if it is unable to execute a command sent by the master.
<i>SYNC object</i>	Synchronisation object
<i>T_PDO</i>	Transmit PDO
<i>Timeout</i>	Error caused by exceeding the maximum allowable time between query and response of devices.
<i>Transformation ratio</i>	This defines the transmission ratio of the reference voltage to the SIN or COS signal voltage. It is used in specifying resolvers.
<i>User-defined unit</i>	Standardized unit with which a distance, speed or acceleration value at maximum resolution can be input.
<i>Watchdog</i>	Equipment that monitors cyclic basic functions in the drive system. Power amplifier and outputs are switched off in the event of error.
<i>Zero-clamp</i>	Taking over the current actual position as the new setpoint position. It is used with the quick-stop function when the position controller is switched in at zero speed and set to the current position.
<i>ZK</i>	DC bus

12.2 Product name

<i>TLC53x</i>	Positioning controller for AC synchronous servomotors
<i>TLCT</i>	Software for commissioning
<i>TLHMI</i>	Hand-held operating unit
<i>TLBRC</i>	Ballast resistor controller
<i>TLHBC</i>	Holding brake controller

13 Index

Numerics

7-segment display, see status display

A

Abbreviations 12-1

Access channels to the Twin Line unit 6-2

Accessories 3-4, 3-11, 10-1

Installation 4-9

wiring 4-62

Analogue

input

offset value 6-47, 6-51

voltage window 6-48, 6-52

input, functioning 7-41

interfaces 7-41

module

analogue input 7-41

analogue output 7-41

connecting 4-43

IOM-C 4-43

setting parameters at output 1 7-41

Setting parameters output 2 7-42

Analogue input

display 5-19

displaying over field bus 5-20

displaying with commissioning software 5-19

Analogue module

IOM-C 3-8

Aperiodic limiting case 5-36

B

Ballast resistor

control

TLBRC 4-64

wiring 4-64

external 4-65

internal 1-5

wiring 4-65

Ballast resistor controller

Dimensions 3-4

setting parameters 5-15

Technical Data 3-11

Brake controller, see holding brake controller

Brake resistor, see ballast resistor

Braking function 7-38

Braking ramp see deceleration ramp

Bus diagnosis 7-36

C

Calibration 7-10

Calibration factor 7-10

- Capture 9-22
- Capturing position values 7-28
- Cascading, max. terminal current for 4-27
- CE mark 1-14
- Checking holding brake 5-12
- Checking limit switch 5-11
- Classical manual movement 6-12
- Commands 9-6
- Commands.driveCtrl 7-22, 8-2, 9-6
- Commissioning 5-1
 - checking holding brake 5-12
 - checking limit switch 5-11
 - controller structure 5-26
 - optimising speed controller 5-31
 - optimising the controller 5-26
 - presets and optimisation 5-39
 - reading motor data 5-9
 - setting parameters 5-13
 - setting parameters for SinCos rotary encoder 5-5
 - software 5-5
 - steps 5-7
 - testing signal interface 5-17
 - tool 5-3
- Commissioning interface, see RS232 interface
- Commissioning software 5-5
 - displaying analogue input 5-19
 - displaying switching states of signal interface 5-18
 - Error display 8-7
 - optimising controller 5-28
 - setting absolute value 5-22
 - setting device parameters 5-15
 - setting reference signal 5-28
 - starting recording 5-29
 - triggering jump function 5-29
- Commissioning tools 5-3
- Communication monitoring 7-36
- Configuration via inputs 4-71
- Connecting encoder 4-37
- Connecting PC 4-35
- Connecting pulse/direction module 4-39
- Connecting resolver 4-47
- control cabinet 4-5
- Controller 3-5
 - determining values
 - "aperiodic limiting case" procedure 5-36
 - "Ziegler Nichols" procedure 5-34
 - procedure "Rigid mechanics and known moments of inertia" 5-
 - entering values 5-29
 - optimisation 5-29
 - optimisation algorithm 5-29
 - optimising 5-26
 - preparation 5-7
 - structure 5-26
- controller
 - structure 5-26

Controller optimisation 1-11
Controller parameters 1-6
Correcting operating error 8-9
Critical gain 5-35
CtrlBlock1 9-11
Current controller
 function 5-27
CurrentControl 9-17

D

Danger classes 2-2
DC bus connection 1-5
 connecting ballast resistor controller 4-64
Declaration of conformity 1-16
Diagnostics 8-1
Diagram
 A/B signals 4-38
Dimension setting 6-42
 offset values 6-26
Dimensions 3-2
Directives 1-14
Disposal 11-1, 11-2, 11-3

E

Earthing
 housing 1-5
Electrical installation 4-11
Electronic gear, function 6-19
EMC
 Requirement
 Motor wiring and sensor wiring 4-20, 4-23
ENABLE signal
 Function 4-41
Encoder simulation module
 ESIM3-C 3-9
ErrMem0 9-35
error class 8-4
Error display and troubleshooting 8-4
error functions in movement mode 8-9
Error messages
 resetting 8-4
Error response
 Meaning 8-4
ESIM3-C
 encoder simulation module 3-9

F

Fan 1-6
Fehlerbehebung 8-4
Field bus
 configuration with TLHMI or TLCT 4-73
 manual setup 4-75
 module
 CAN-C 4-53

- IBS-C 4-60
- MODB-C 4-58
- PBDP-C 4-51
- RS485-C 4-56
- operation 4-71
- Field bus mode 1-11
- Following error
 - function 6-22
 - monitoring function 7-34
- Forcing 5-18, 5-20

G

- Gear 9-15
- Gear factor 1-10, 6-19, 6-21
- Global status bits, status bits 6-7

H

- HMI hand-held operating unit
 - displaying switching states of signal interface 5-19
 - Error display 8-8
 - input reference signal 5-29
 - overview 5-3
 - setting device parameters 5-15
 - triggering jump function 5-30
- Holding brake controller
 - connecting 4-62
 - dimensions 3-4
 - Function 7-38
 - Technical Data 3-11
- Home 9-16
- Home.p_SrchIdx 6-38, 9-17
- Home.startHome 6-31, 6-36, 9-16

I

- I/O 9-23
- I²t monitoring 7-33
- Incremental encoder 7-44
- Installation
 - electrical 4-11
 - mechanical 4-5
- installation
 - clearances 4-5, 4-6
 - Mechanical 4-5
- Intended use 2-1
- Interface signal
 - ACTIVE_CON 7-38
 - FAULT_RESET 7-21
 - STOP 7-32
 - TRIGGER 7-1

J

- Jerk filter 7-19

L

Labels

attaching 4-7

Laying motor cables 4-20

LED

for DC bus voltage 1-6

for operating signals 1-6

Limit switch

Monitoring function 7-32

reference movement with index pulse 6-39

Reference movement without index pulse 6-33

retracting drive 7-33

Software limit switch 7-31

LIMN, see limit switch

LIMP, see limit switch

Line connection

Alternating current 4-15, 4-17

Connecting 24 V power supply 4-26

List 9-20

List control 1-11

Overview 7-1

Settings 7-1

List1Data0 9-21

List2Data0 9-21

M

M1 9-24

M1..M4, see module slots

M2 9-26

M3 9-26

M3.EsimResol 7-46, 9-26

M4 9-26

Mains connection 1-5

Mains filter, unit identification 4-9

Mains reactor 3-11

Maintenance 11-1, 11-2

Manual 9-13

Manual movement

motion parameter 6-10

Mechanical installation 4-5

Mechanics, Layout for control system 5-31

Module

CAN-C 1-9, 4-53

electronic gear 6-19

ESIM3-C 1-9

HIFA-C 1-8, 4-45

IBS-C 1-9, 4-60

IOM-C 1-8, 4-43

MODB-C 1-9, 4-58

PBDP-C 1-9, 4-51

PULSE-C 1-8, 4-39

RESO-C 1-8, 4-47

RS422-C 1-8, 4-37

RS485-C 1-9, 4-56

wiring 4-45–4-60

- Module slots 1-6
- Modules
 - overview 1-8, 3-7
- Monitoring
 - functions 7-30
 - parameters 7-34
- Monitoring functions 2-4
- Motion 9-1, 9-12
- Motor connection 1-5, 4-19
- Motor data
 - data set 5-9
 - Reading 5-9
- Motor data set 1-6
- Movement parameters 1-6

N

- Name plate, mains filter information 4-9
- Nameplate 4-7

O

- Offset positioning 6-25
- Open Collector circuit 4-42
- Operating function
 - position control at M1 7-44
- Operating mode
 - Current control 6-45
 - current control 1-11, 6-45
 - electronic gear 1-10, 6-19
 - manual mode 6-10
 - manual movement 1-10, 6-10
 - monitoring status 6-5
 - Oscillator mode 6-50
 - oscillator mode 1-11, 6-50
 - point-to-point mode 1-10, 6-17
 - Referencing 6-28
 - referencing 1-11, 6-28
 - setting 6-4
 - speed mode 1-10, 6-15
 - status monitoring 6-8
- Operating modes 6-1
 - overview 1-10
- Operating states and transitions 8-2
- Optimisation 5-28
- optimising control loops 5-26
- Optimising presets 5-39
- Oscillator 9-18
- Overview 5-2

P

- PA 9-6
- Parallel connection of two units 4-24
- Parameter
 - view 5-13, 9-2
- Parameter group

- capture 9-22
- Commands 9-6
- CtrlBlock1 9-11
- CurrentControl 9-17
- ErrMem0 9-35
- Gear 9-15
- Home 9-16
- I/O 9-23
- List 9-20
- List1Data0 9-21
- List2Data0 9-21
- M1 9-24
- M2 9-26
- M3 9-26
- M4 9-26
- Manual 9-13
- Motion 9-12
- motion 9-1
- Oscillator 9-18
- PA 9-6
- PTP 9-14
- Servomotor 9-8
- Settings 9-4
- Status 9-28
- Teach-In 9-19
- VEL 9-14
- Parameter memory 1-6
- Parameter name 6-31, 6-36, 6-38, 7-22, 7-46, 8-2, 9-6, 9-9, 9-16, 9-17, 9-26, 9-34
- Capture.TrigLevl 7-29, 9-22
- Capture.TrigPact1 7-29, 9-22
- Capture.TrigPact2 7-29, 9-22
- Capture.TrigPref1 7-29, 9-23
- Capture.TrigPref2 7-29, 9-23
- Capture.TrigSign 7-29, 9-22
- Capture.TrigStart 7-29, 9-22
- Capture.TrigStat 7-29, 9-22
- Capture.TrigType 7-29, 9-22
- Commands.default 9-6
- Commands.del_err 8-9, 9-6
- Commands.eeprSave 9-6
- Commands.OnlAuto 6-2, 9-6
- Commands.SetCtrl 5-15, 9-6
- Commands.stateDef 9-6
- Commands.stateSave 9-6
- CtrlBlock1.Filt_nRef 5-32, 9-11
- CtrlBlock1.l_max 5-15, 9-11
- CtrlBlock1.K1n 9-11
- CtrlBlock1.KFAp 9-11
- CtrlBlock1.KFAp2 9-11
- CtrlBlock1.KFDn 9-11
- CtrlBlock1.KFPn 9-11
- CtrlBlock1.KFPp 9-11
- CtrlBlock1.KPn 5-31, 9-11
- CtrlBlock1.KPp 5-41, 9-11
- CtrlBlock1.n_max 5-15, 9-11

CtrlBlock1.TNn 5-31, 9-11
CtrlBlock1.TVn 9-11
CtrlBlock1.TVp 9-11
CurrentControl.curr_targ 6-46, 9-18
CurrentControl.startCurr 6-45, 9-17
CurrentControl.stateCurr 6-46, 9-18
ErrMem0.AmpOnCnt 8-9, 9-35
ErrMem0.Class 8-9, 9-35
ErrMem0.ErrNum 8-9, 9-35
ErrMem0.ErrQual 8-9, 9-35
ErrMem0.Time 8-9, 9-35
Gear.accOffs 6-27, 9-15
Gear.decOffs 6-27, 9-16
Gear.denGear 6-21, 9-15
Gear.DirEnGear 6-22, 9-15
Gear.ModeOffs 6-25, 9-16
Gear.n_tarOffs 6-27, 9-15
Gear.numGear 6-21, 9-15
Gear.p_absOffs 6-27, 9-15
Gear.p_relOffs 6-27, 9-15
Gear.phomeOffs 6-27, 9-15
Gear.startGear 6-20, 9-15
Gear.stateGear 6-20, 9-15
Gear.stateOffs 6-27, 9-15
Home.DefPosTyp 6-33, 6-38, 9-17
Home.p_disHome 6-32, 9-16
Home.p_outHome 6-32, 6-37, 9-16
Home.RefAppPos 6-33, 6-38, 9-17
Home.RefSwMod 6-33, 6-34, 6-38, 6-40, 9-17
Home.startSetp 6-42, 9-16
Home.stateHome 6-31, 6-36, 6-42, 9-16
Home.v_Home 6-32, 6-37, 9-16
Home.v_outHome 6-32, 6-37, 9-16
I/O.IW0_act 9-23
I/O.IW1_act 9-23
I/O.OutTrig 7-5, 9-24
I/O.QW0 9-24
L1Data0.posList1 7-3, 9-21
L1Data0.signList1 7-3, 9-21
L1Data0.typeList1 7-3, 7-9, 9-21
L1Data0.velList1 7-3, 9-21
L2Data0.posList2 7-4, 9-21
L2Data0.signList2 7-4, 9-21
L2Data0.typeList2 7-3, 7-9, 9-21
L2Data0.velList2 7-4, 9-22
List.actList 7-2, 9-20
List.bgnList1 7-2, 9-20
List.bgnList2 7-3, 9-20
List.chgList1 9-20
List.cntList1 7-2, 9-20
List.cntList2 7-2, 9-20
List.endList1 7-2, 9-20
List.endList2 7-3, 9-20
List.startList 7-2, 9-20
List.stateList 7-2, 9-20
List.typeList1 9-20

List.typeList2 9-20
 M1.AnalogIn2 5-20, 7-41, 9-24
 M1.AnalogIn3 5-20, 7-41, 9-24
 M1.AnalogO1 5-20, 7-42, 9-24
 M1.AnalogO2 5-20, 7-43, 9-25
 M1.AOut1IScl 7-42, 9-25
 M1.AOut2NScl 7-42, 9-25
 M1.filterval 9-25
 M1.Fkt_AOut1 7-41, 9-24
 M1.Fkt_AOut2 7-42, 9-25
 M1.M1_EncMod 7-44, 9-25
 M1.m1m2pdlim 7-45, 9-25
 M1.PULSE-C 9-24
 M1.RS422-C 7-44, 9-24
 M1.rs422dir 7-45, 9-25
 M2.RS422Inc 9-26
 M2.SetEncPos 5-21, 5-22, 9-26
 M4.addrCan 9-27
 M4.addrPbd 9-27
 M4.addrSer 9-26
 M4.baudCan 9-27
 M4.baudlbs 9-26
 M4.baudSer 9-26
 M4.busCycle 7-37, 9-27
 M4.busDiag 9-27
 M4.busError 7-37, 9-27
 M4.busRxD 7-36, 9-27
 M4.busRxD5_8 7-36, 9-27
 M4.busTout 7-37, 9-27
 M4.busTxD 7-36, 9-27
 M4.busTxD5_8 7-36, 9-27
 M4.profilCan 9-27
 M4.profillbs 9-26
 M4.profilPbd 9-27
 M4.profilSer 9-26
 M4.toutCan 9-27
 M4.toutlbs 9-27
 M4.toutSer 9-26
 Manual.dist_Man 6-13, 9-13
 Manual.l_maxMan 5-15, 9-13
 Manual.n_fastMan 6-12, 6-13, 9-13
 Manual.n_slowMan 6-12, 6-13, 9-13
 Manual.startMan 6-11, 9-13
 Manual.statusMan 6-11, 9-13
 Manual.step_Man 6-12, 9-13
 Manual.time_Man 6-12, 9-13
 Manual.typeMan 6-11, 9-13
 Motion.acc 7-18, 9-13
 Motion.acc_type 7-18, 9-12
 Motion.aNormDen 7-11, 9-12
 Motion.aNormNum 7-11, 9-12
 Motion.dec 7-18, 9-13
 Motion.Filt_jerk 7-19, 9-12
 Motion.invertDir 5-23, 7-26, 9-12
 Motion.n_max0 9-12
 Motion.pNormDen 7-11, 9-12

Motion.pNormNum 7-11, 9-12
Motion.SW_Enabl 7-31, 9-12
Motion.SW_LimN 7-31, 9-12
Motion.SW_LimP 7-31, 9-12
Motion.v_target0 9-12
Motion.vNormDen 7-11, 9-12
Motion.vNormNum 7-11, 9-12
Oscillator.n_RefAna 6-51, 9-19
Oscillator.startOszi 6-50, 9-18
Oscillator.stateOszi 6-51, 9-19
PA.F_maxChop 9-7
PA.I_maxfw 9-7
PA.I_maxPA 9-7
PA.I_maxPAr 9-8
PA.I_nomPA 9-7
PA.I_nomPAr 9-8
PA.I2t_n0PA 7-34, 9-8
PA.I2t_warnB 7-34, 9-7
PA.I2tB 7-34, 9-7
PA.I2tPA 7-33, 9-7
PA.Kifw 9-7
PA.Klid 9-7
PA.Kliq 9-7
PA.KPfw 9-7
PA.KPid 9-7
PA.KPiq 9-7
PA.P_maxB 9-8
PA.P_maxBusr 4-70, 9-8
PA.Serial 9-7
PA.T_maxPA 7-33, 9-7
PA.T_warnPA 7-33, 9-7
PA.U_BalOff 9-7
PA.U_BalOn 9-7
PA.U_maxDC 9-7
PA.U_minDC 9-7
PTP.continue 6-18, 9-14
PTP.p_absPTP 6-4, 6-18, 9-14
PTP.p_relPTP 6-18, 9-14
PTP.statePTP 6-7, 6-18, 9-14
PTP.v_tarPTP 6-18, 9-14
Servomotor.adj1Sen 9-8
Servomotor.adj2Sen 9-8
Servomotor.CountSen 9-9
Servomotor.fR 9-9
Servomotor.I_0M 9-11
Servomotor.I_maxM 9-9
Servomotor.I_nomM 9-9
Servomotor.I2tM 9-9
Servomotor.infoM 9-8
Servomotor.JM 9-9
Servomotor.KeM 9-9
Servomotor.L_qM 9-9
Servomotor.M_maxM 9-9
Servomotor.M_nomM 9-9
Servomotor.n_maxM 9-9
Servomotor.n_nomM 9-9

Servomotor.name1M 9-10
Servomotor.name2M 9-10
Servomotor.name3M 9-10
Servomotor.name4M 9-10
Servomotor.PolepairM 9-9
Servomotor.PolepairR 9-10
Servomotor.principIM 9-8
Servomotor.R_UVM 9-9
Servomotor.reserve 9-8
Servomotor.ResolutM 9-10
Servomotor.SensorM 9-9
Servomotor.T_warnM 9-10
Servomotor.Tcal_t1 9-10
Servomotor.Tcal_t2 9-10
Servomotor.Tcal_t3 9-10
Servomotor.Tcal_t4 9-10
Servomotor.Tcal_t5 9-10
Servomotor.Tcal_t6 9-10
Servomotor.Tcal_t7 9-10
Servomotor.Tcal_t8 9-10
Servomotor.Tcal_u1 9-10
Servomotor.Tcal_u2 9-10
Servomotor.Tcal_u3 9-10
Servomotor.Tcal_u4 9-10
Servomotor.Tcal_u5 9-10
Servomotor.Tcal_u6 9-10
Servomotor.Tcal_u7 9-10
Servomotor.Tcal_u8 9-10
Servomotor.TempTypeM 9-10
Servomotor.TypeM 9-8
Servomotor.U_nomM 9-9
Settings.CommutChk 9-5
Settings.f_Chop 5-16, 9-4
Settings.Flt_AC 9-5
Settings.Flt_pDiff 7-34, 9-5
Settings.I_maxSTOP 5-15, 7-21, 9-5
Settings.I_RefScal 6-47, 9-4
Settings.IO_mode 5-23, 6-3, 9-5
Settings.name1 9-4
Settings.name2 9-4
Settings.offset_0V 6-47, 6-51, 9-4
Settings.p_maxDiff 7-34, 9-4
Settings.p_win 7-24, 9-4
Settings.p_winTime 7-24, 9-4
Settings.p_winTout 7-24, 9-4
Settings.Password 9-4
Settings.SignEnabl 7-32, 9-5
Settings.SignLevel 7-32, 9-5
Settings.SignQstop 7-20, 9-5
Settings.t_brk_off 7-39, 9-4
Settings.t_brk_on 7-39, 9-4
Settings.TL_BRC 5-15, 9-5
Settings.win_10V 6-48, 6-52, 9-5
Status.acc_ref 9-34
Status.ActCtrl 9-33
Status.action_st 9-32

Status.AnalogIn 5-20, 9-28
Status.driveStat 6-6, 9-29
Status.FltSig 9-31
Status.FltSig_SR 9-32
Status.I_act 9-33
Status.I_ref 9-33
Status.I2tB_act 9-33
Status.I2tM_act 9-33
Status.I2tPA_act 9-33
Status.Id_Act 9-33
Status.Id_ref 9-33
Status.IntSigSr 7-31, 9-33
Status.lu_act 9-34
Status.lv_act 9-34
Status.n_act 9-33
Status.n_ref 9-33
Status.n_refOffs 9-34
Status.p_abs 9-33
Status.p_absall 9-35
Status.p_act 9-33
Status.p_actusr 9-34
Status.p_addGear 9-34
Status.p_dif 9-33
Status.p_diffind 6-37, 9-35
Status.p_DifPeak 9-28
Status.p_jerk 9-34
Status.p_ref 9-33
Status.p_refGear 9-34
Status.p_refM1 9-35
Status.p_refOffs 9-34
Status.p_refusr 9-35
Status.p_remaind 7-16, 9-34
Status.p_target 9-34
Status.p_tarOffs 9-34
Status.PDIFM1M2 7-45, 9-35
Status.serial_no 9-28
Status.Sign_SR 9-30
Status.StopFault 8-9, 9-35
Status.TM_act 9-34
Status.TPA_act 9-34
Status.ud_ref 9-33
Status.UDC_act 9-34
Status.uq_ref 9-33
Status.v_jerk 9-34
Status.v_jerkusr 9-34
Status.v_ref 9-34
Status.v_refGear 9-34
Status.v_refM1 9-35
Status.v_refusr 9-35
Status.v_target 9-34
Status.xMode_act 6-29, 6-32, 6-37, 6-43, 7-25, 9-30
Teach.memNrTeac 7-8
Teach.p_actTeac 7-8
Teach.stateTeac 7-8
Teach.storeTeac 7-8
VEL.stateVEL 6-15, 9-14

- VEL.velocity 5-13, 6-15, 9-2, 9-14
- Parameter sets 6-8
- Parameter value
 - inputs for electronic gear 6-21
- Parametername
 - Teach.memNrTeac 9-19
 - Teach.p_actTeac 9-19
 - Teach.stateTeac 9-19
 - Teach.storeTeac 9-19
- Parameters 9-1
 - overview 9-4
 - setting 5-13
- Pin assignment 4-28–4-60
- Position control
 - disable at M1 7-45
 - enable at M1 7-44
- Position controller
 - control loop 5-26
 - function 5-27
 - optimising 5-41
- Position encoder
 - Setting absolute position 5-22
- Position/signal list 7-4
- Position/speed list 7-6
- Positioning
 - limits 7-30
 - window 7-24
- Power connection 4-15, 4-17
- Product name 12-6
- Profile generator 6-9
- PTP 9-14

Q

- Qualifications, personnel 2-1
- Quick-Stop function 7-20

R

- Ramp
 - shape 7-18
 - steepness 7-18
- Ramp function 7-18
- REF, see reference switch
- Reference movement 6-30
 - Adjusting calibration factor 7-12
 - Direction reversal 6-34, 6-40
 - movement to switch range 6-34, 6-40
 - with index pulse 6-36
 - without index pulse 6-31
- Reference signal
 - from an encoder 1-10, 6-19
 - from an NC controller 1-10, 6-19
 - input with the HMI hand-held operating unit 5-29
 - set with commissioning software 5-28
- Reference switch
 - reference movement with index pulse 6-39

- reference movement without index pulse 6-33
- Reference variable filter 5-32, 5-40
- Residual value 7-16
- Residual value with user-defined standardisation 7-16
- Resolution
 - for calculation of the gear factor 6-21
 - SinCos encoder 4-46
- Reversal of direction of rotation 6-21, 7-26
- RS232 interface 1-6, 4-35, 12-4

S

- Scope of supply 1-2
- Selecting the chopper frequency 5-15
- Service 11-1
- Service address 11-2
- Servomotor 9-8
- Servomotor.L_dM 9-9
- Servomotor.T_maxM 9-9
- Setting deceleration ramp 7-18
- Settings 9-4
- Shipping 11-2, 11-3
- Signal generator 1-11
- Signal inputs
 - Assignment 4-28
 - Circuit diagram 4-42
 - Circuit examples 4-71-??
- Signal interface
 - assignment 4-28
 - function 1-6
 - testing inputs and outputs 5-17
 - wiring examples 4-71-??
- SinCos
 - connecting 4-45
 - resolution 4-46
- SinCos rotary encoder
 - position processing 5-21
 - setting absolute position 5-21
 - setting parameters 5-21
- Slots, see module slots
- Software limit switch 7-31
- Speed controller
 - function 5-27
 - setting 5-31
- Speed limitation 6-22
- SRM, see SinCos rotary encoder
- SRS, see SinCos rotary encoder
- Standardisation
 - residual value 7-16
- Standardisation factor
 - Acceleration 7-15
 - Positioning 7-12
 - setting 7-12
 - Speed 7-14
- Standardisation, residual value of 7-16
- Standards 1-14

Standstill window 7-24
Starting recording 5-29
Status 9-28
Status display 1-5, 8-1
Status.p_jerkusr 9-34
Storage 11-2, 11-3

T

Teach-In 9-19
 Residual value 7-16
Teach-in 1-12, 7-7
Technical data 3-1
Temperature monitoring 7-33
Terminal angle 4-10
Terms 12-1
Time diagram
 Braking function 7-40
 Pulse direction signal 4-40
 Pulse forward/back signal 4-41
TLCT 5-5
Trigger channels 7-28
Triggering jump function 5-29, 5-30
Troubleshooting 8-1
Twin Line HMI, see HMI hand-held operating unit
Twin Line unit
 connecting in parallel 4-24
 Connecting motor 4-19
 Connecting signal interface 4-28
 Installation 4-5
 Installation clearances 4-5, 4-6
 Wiring 24 V connection 4-26
 Wiring modules 4-45–4-60
 Wiring up the line connection 4-15–4-17
Type code 1-4

U

Unit overview 1-5
United inching 6-13

V

VEL 9-14
Voltage reduction 7-40

W

Wiring examples 4-71

X

x_end, x_err, x_add_info 6-7

Z

Ziegler Nichols procedure 5-34

