



Synchronous Servo Motors

Catalogue: 192-060011 N5 / UK
Version 5 / December 2000



Contents

| | |
|--|-----------|
| Synchronous servo motors manufactured by Parker Hannifin, Elektromechnik Europa | 4 |
| Standard servo motors of the HJ range..... | 5 |
| Options | 6 |
| Motor overview of HJ – motors | 7 |
| Dimensional drawings..... | 8 |
| HJ96C6-44S | 8 |
| HJ116C6-64S / HJ116E6-88S | 8 |
| HJ155A8-88S / HJ155E8-130S / HJ155G8-135S..... | 8 |
| HJ155G8-135S with fan..... | 9 |
| HJ190J8-150S with fan..... | 9 |
| Engine characteristics curves..... | 10 |
| Highly dynamic synchronous servo motors HDY..... | 14 |
| Options | 15 |
| Motor overview of HDY – motors | 16 |
| Dimensional drawings..... | 17 |
| HDY55C4-32S | 17 |
| HDY70C4-44S / HDY70E4-44S..... | 17 |
| HDY92C4-44S / HDY92E4-44S..... | 17 |
| HDY115A6-64S / HDY115A6-88S / HDY115C6-88S / HDY115E6-88S / HDY115G6-88S | 18 |
| HDY142C6-88S / HDY142G6-88S | 18 |
| Motor characteristics curves..... | 19 |
| Connecting cable to motor | 25 |
| Resolver cable for HJ and HDY motors | 25 |
| Motor cable for HJ and HDY – motors | 26 |
| SinCos© cable for HJ and HDY motors | 28 |
| Order code motors | 29 |
| Order code cables | 30 |

Synchronous servo motors manufactured by Parker Hannifin, Elektromechanik Europa

Today's levels of electrical drive technology mean that different specific synchronous servo motors are required depending on the application in question.

HDY synchronous servo motors

The outstanding feature of the HDY synchronous servo motors is their low rotor inertia torque. Typical applications for these motors would be packaging machines, automatic press or assembly equipment, in which rapid acceleration and delay is required.

5 model sizes are available with edge lengths of 55, 70, 92, 115 and 142 in a power range of between 0.4 and 21 Nm.

HJ synchronous servo motors

The motors of the HJ range have high-quality Neodym iron-boron magnets and their rotor inertia torque is 2 to 3 times higher. The shafts (with large diameters) and the design of the rotor and bearing ensure that these motors have a higher level of shaft strength. Parker's HJ synchronous servo motors have the outstanding feature of good synchronous running properties even when running at low speeds. Typical applications for these motors would be in tooling and printing machines as well as handling robots. The HJ motors have smooth surfaces and recesses in the assembly area, which is why dirt deposits are reduced to a minimum and it is very easy to fit this unit to the gearbox.

Four model sizes of 96, 116, 155 and 190 are available in a power range of between 3.0 and 91 Nm.

Both the HDY and HJ ranges can be fitted with a stationary/parking brake on request. As an alternative to the resolver feedback system, SinCos^{®1} singleturn or an absolute value sensor SinCos[®] multiturn system can be supplied.

When fitted with SV drive² and the COMPAX compact servo control unit, these motors form a drive concept for use in mains power supplies of between 230V and 460V AC.

¹ The term SinCos[®] stated in the motor catalogue is a registered trademark of the Stegmann company.

² Only supports resolver for determining motor position.

Standard servo motors of the HJ range



General characteristic data:

- Sinusoidal EMC.
- Painted mat black.
- Nitrile shaft seal.
- IP65³ type of protection (shaft IP64).
- Insulation class F.
- Maximum ambient temperature: 40°C
- Any installation position.
- Standard flange: standard in acc. with DIN 42955; IEC72.
- Basic body: aluminium extruded moulding
- Flange: aluminium
- Connector sockets can be rotated into almost any position (secured using a torque of 10 Nm \pm 2 Nm)
- Treble torque rating is possible for up to 3 seconds.
- Thermal sensor KTY84-130: arranged in the winding.
Switch-off temperature of COMPAX: 150°C \pm 8,5°

³ with fan IP54

Version:

- With spline
- Spur thread
HJ96: M6x15
HJ116: M8x20
HJ155: M12x30
HJ190: M12x30
- Integrated resolver.

Area of application

- Packaging machines,
- shelf transport technology,
- wood machining,
- handling robots, etc.

Options

Stationary/parking brake

The motors can be fitted with a stationary/parking brake on request. The brake is fitted in the motor housing behind the A flange (in HJ96 on the B side). This changes the mechanical dimensions of the motor. The brake is fed voltage by the motor cable.

Technical data for the 24V holding brakes:

| Motor | Type | Holding torque [Nm] | J [kgmm ²] | Power [A] | Switch times [ms] | |
|-------|--------------------------|---------------------|------------------------|-----------|-------------------|-------|
| | | | | | open | close |
| HJ96 | Spring pressure brake | 5,0 | 13 | 0,5 | 50 | 20 |
| HJ116 | Spring pressure brake | 13,5 | 40 | 0,5 | 70 | 30 |
| HJ155 | Spring pressure brake | 40,0 | 200 | 1,1 | 110 | 40 |
| HJ190 | Permanent solenoid brake | 80,0 ⁴ | 3180 | 1,5 | 97 | 53 |

Attention: The stationary/parking brake does not permit any active braking.

Sensor system

A resolver is fitted in the motors as standard.

The motors can be optionally supplied with the following sensors:

- SinCos© singleturn encoder or
- SinCos© multiturn absolute value sensor



Caution! It's only with SinCos model SCS60 and SCM60

Do not release rear motor cover. The SinCos© is fixed by the rear motor cover.

Danger! If this is released, the motor will behave in an uncontrollable manner.



By using SinCos©, the rated torque must be reduced about 10% for a correct dimensioning.

⁴ Applies at 20°C: reduces by 30% when at 120°C.

Motor overview of HJ – motors

| Motor type | Continual stall torque M_0 Nm | Continual stall current I_0 A | Resistance Ω | Inductance μH | Entire torque constant ⁵ K_T Nm/A | Rotor inertia J kgmm ² | Weight m kg | Length ⁶ without / with brake A mm | Power voltage ac U V ac | Rated speed N _{rated} R.P.M | Rated torque M _{rated} Nm | Rated current I _{rated} A _{eff} | Rated power P _{rated} kW |
|---------------------|---------------------------------------|---------------------------------------|------------------------|-----------------------|--|---|-------------------|---|-------------------------------|--|--|---|---|
| HJ ... | 3,0 | 5,8 | 1,60 | 3500 | 0,51 | 330 | 5,0 | 218 / 258 | 230 | 4500 | 2,6 | 5,1 | 1,2 |
| | | | | | | | | | 400 | 5000 | 2,5 | 4,9 | 1,3 |
| 116C6-64S | 5,0 | 6,7 | 1,80 | 6800 | 0,75 | 750 | 7,0 | 221 / 257 | 230 | 3000 | 4,6 | 6,0 | 1,4 |
| | | | | | | | | | 400 | 5000 | 4,0 | 5,0 | 2,1 |
| | | | | | | | | | 460 | 5000 | 4,0 | 5,0 | 2,1 |
| 116E6-88S | 7,2 | 7,0 | 1,70 | 7700 | 1,02 | 990 | 8,5 | 246 / 282 | 230 | 2200 | 6,5 | 6,2 | 1,5 |
| | | | | | | | | | 400 | 4000 | 5,4 | 5,3 | 2,3 |
| | | | | | | | | | 460 | 4600 | 5,0 | 4,7 | 2,5 |
| 155A8-88S | 11,5 | 11,2 | 0,77 | 3800 | 1,02 | 2200 | 13,5 | 237 / 276 | 400 | 4000 | 8,3 | 8,3 | 3,5 |
| | | | | | | | | | 460 | 4600 | 7,2 | 7,1 | 3,6 |
| 155E8-130S | 25,0 | 16,0 | 0,45 | 5200 | 1,53 | 6500 | 23,0 | 325 / 369 | 400 | 2800 | 18,5 | 12,3 | 5,4 |
| | | | | | | | | | 460 | 3200 | 16,9 | 11,7 | 5,7 |
| 155G8-135S | 32,0 | 21,0 | 0,37 | 4300 | 1,57 | 8600 | 28,0 | 369 / 408 | 400 | 2600 | 22,8 | 15,8 | 6,4 |
| | | | | | | | | | 460 | 3000 | 20,5 | 13,6 | 6,7 |
| 155G8-135S with fan | 46,0 | 30,0 | 0,37 | 4300 | 1,57 | 8600 | 31,0 | 432 / 471 | 400 | 2600 | 38,5 | 26,4 | 10,1 |
| | | | | | | | | | 460 | 3000 | 37,2 | 26,1 | 11,3 |
| 190J8-150S with fan | 91,0 | 52,0 | 0,18 | 1900 | 1,74 | 21000 | 50,0 | 615 | 400 | 2400 | 70,0 | 40,0 | 17,6 |
| | | | | | | | | | 460 | 2800 | 58,0 | 34,0 | 17,0 |

Tolerance: $\pm 10\%$.

The general motor values have been determined in accordance with:
the British standard BS4999 or the international Standard IEC34 • Overtemperature: 110K

Assumed is that the air can circulate freely to all sides (mounting distance approx. 30% of the edge length)

When the rated data was determined, the following tolerances were also taken into consideration:

- 10% mains power voltage.
- 17V voltage drop in the final stage.
- 10% voltage control reserve for controlled operation under the rated conditions.

The following were not taken into consideration:

- Tolerance ($\pm 10\%$) of torque constants, motor inductivity and motor resistance.
- Temperature dependency on torque constants and motor resistance.

⁵ To determine torque: torque = 0,71 * entire torque constant * transverse current (see User Guide COMPAX)

⁶ See next page.

Dimensional drawings

HJ96C6-44S

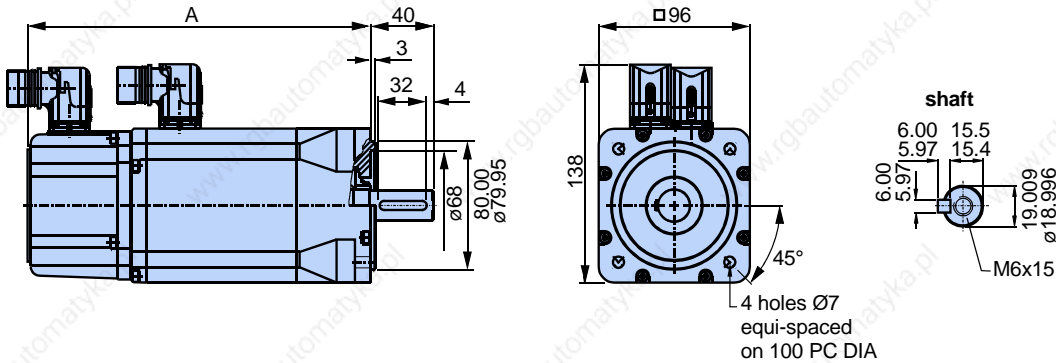

HJ116C6-64S / HJ116E6-88S

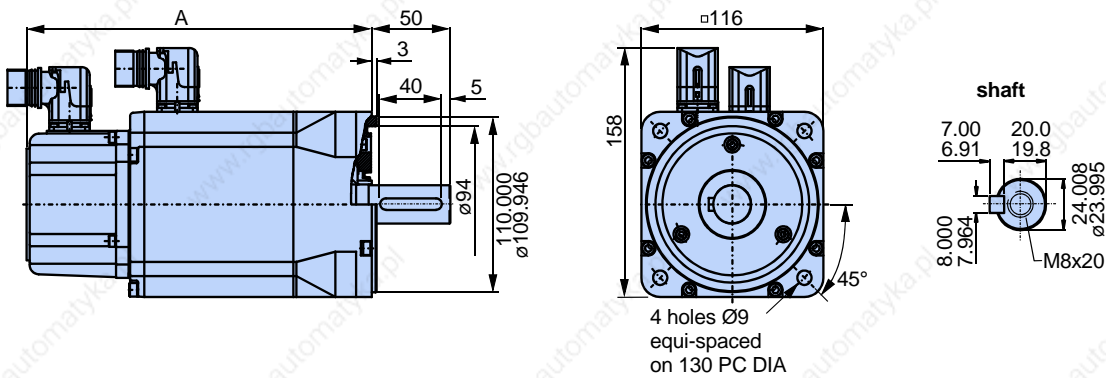

HJ155A8-88S / HJ155E8-130S / HJ155G8-135S

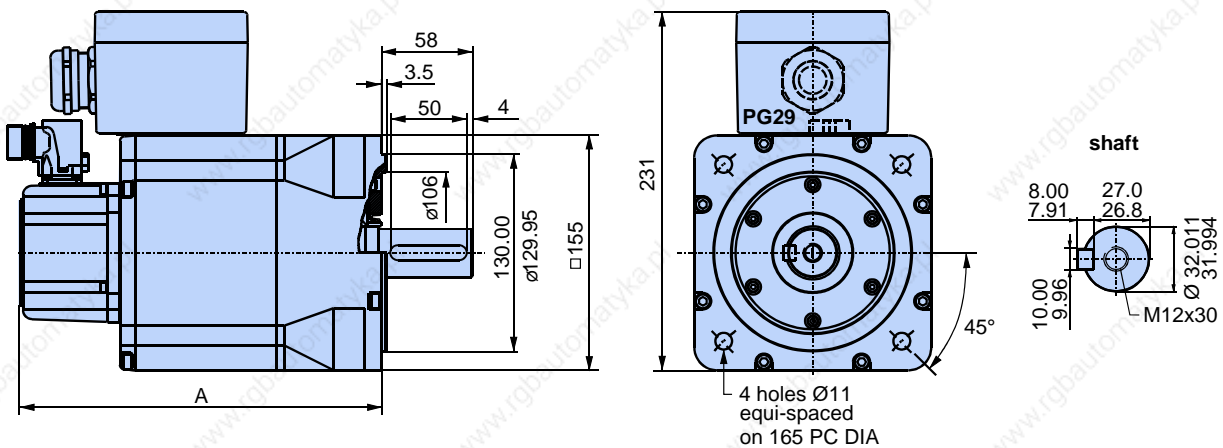

You can find the CAD-files of the dimensional drawings in the "dxf and "mi" format on our homepage.

HJ155G8-135S with fan

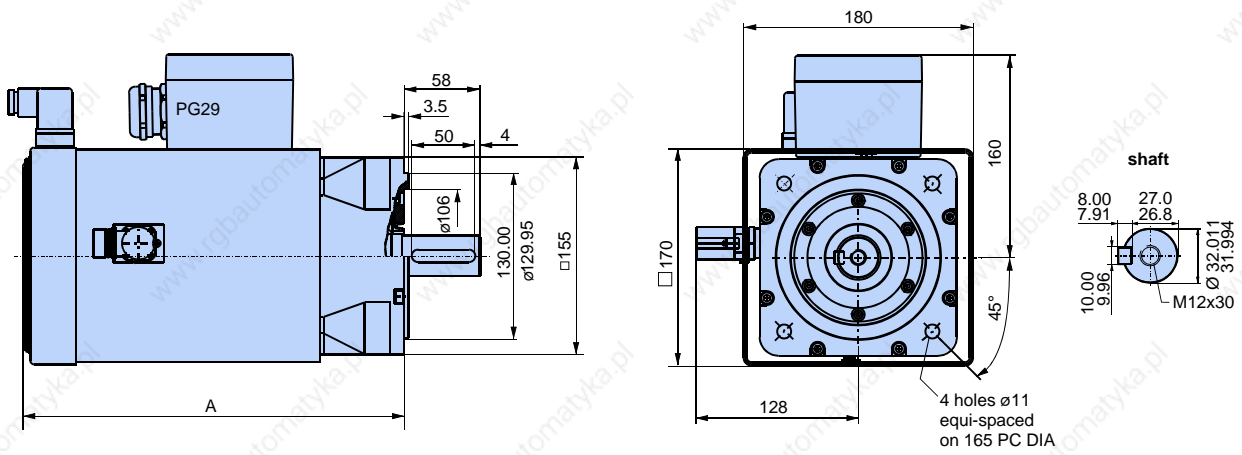

HJ190J8-150S with fan

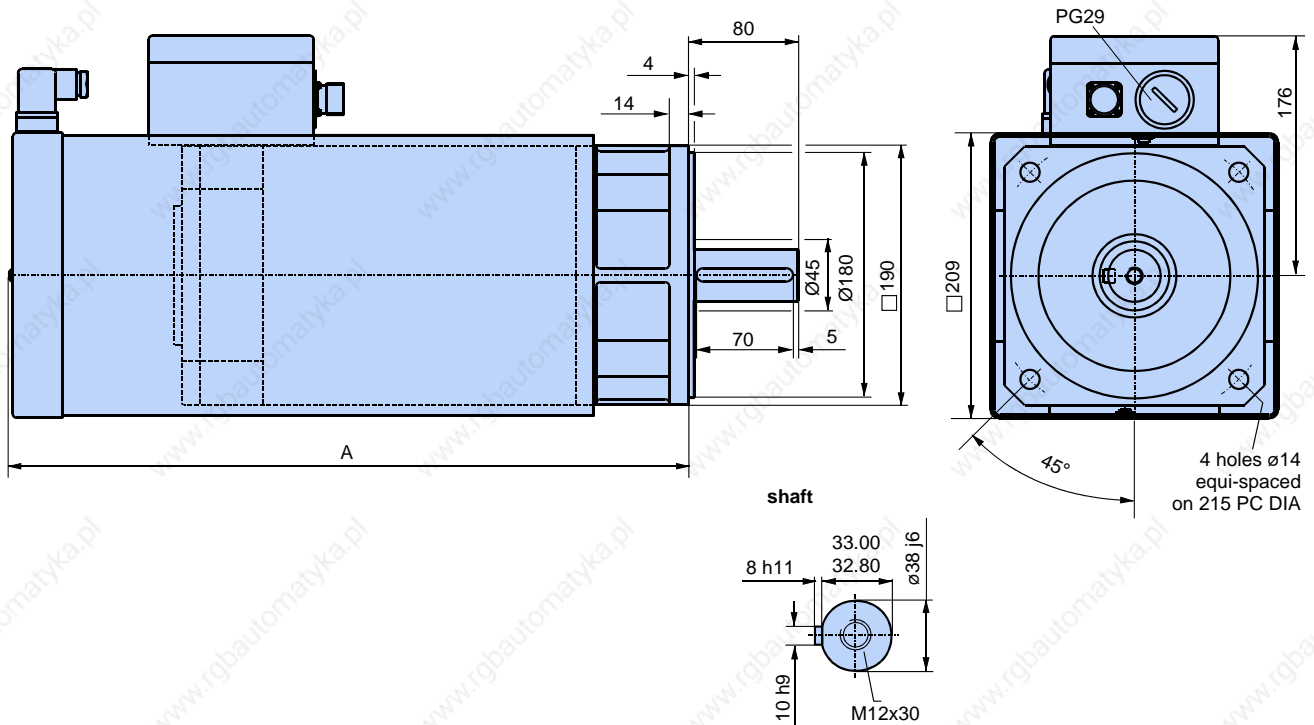

You can find the CAD-files of the dimensional drawings in the "dxf and "mi" format on our homepage.

Engine characteristics curves

HJ96C6-44S

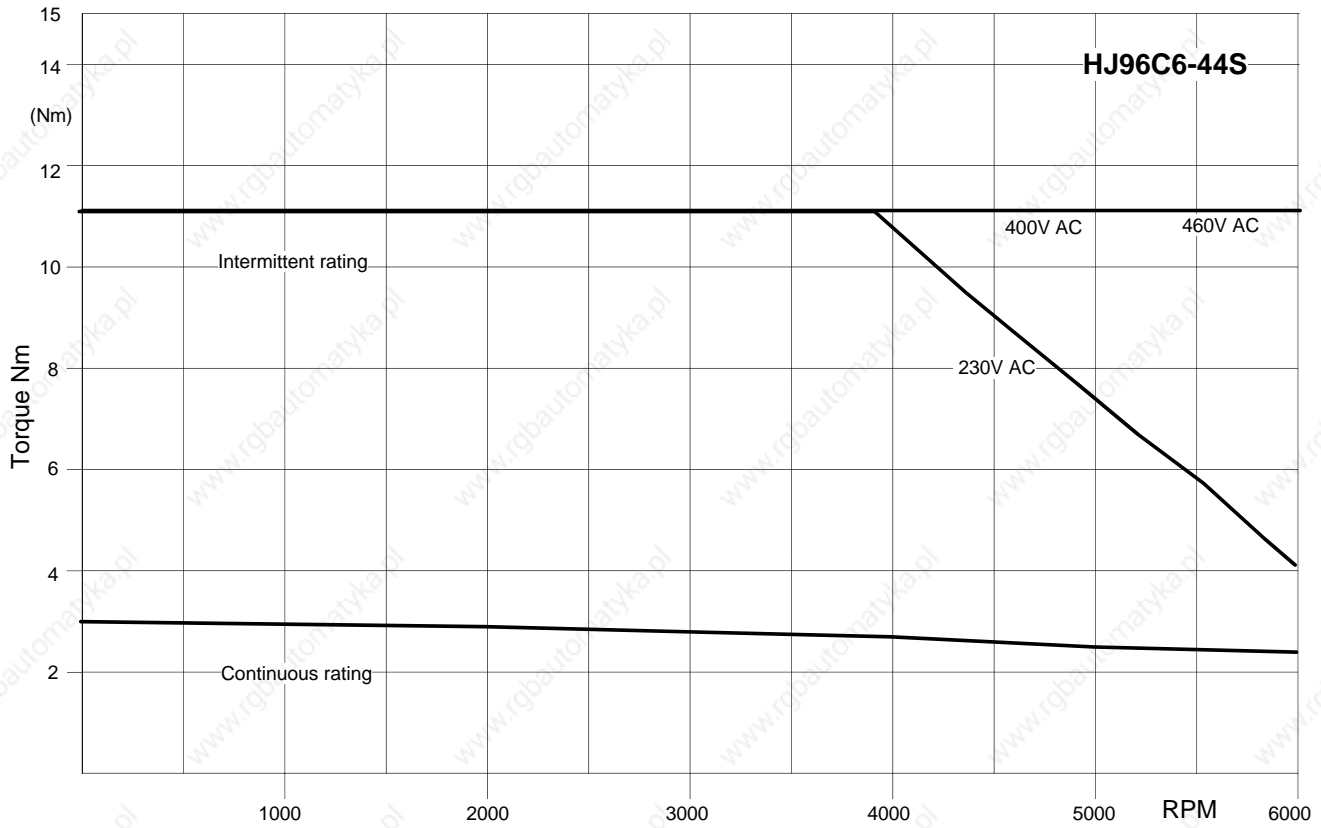

HJ116C6-64S

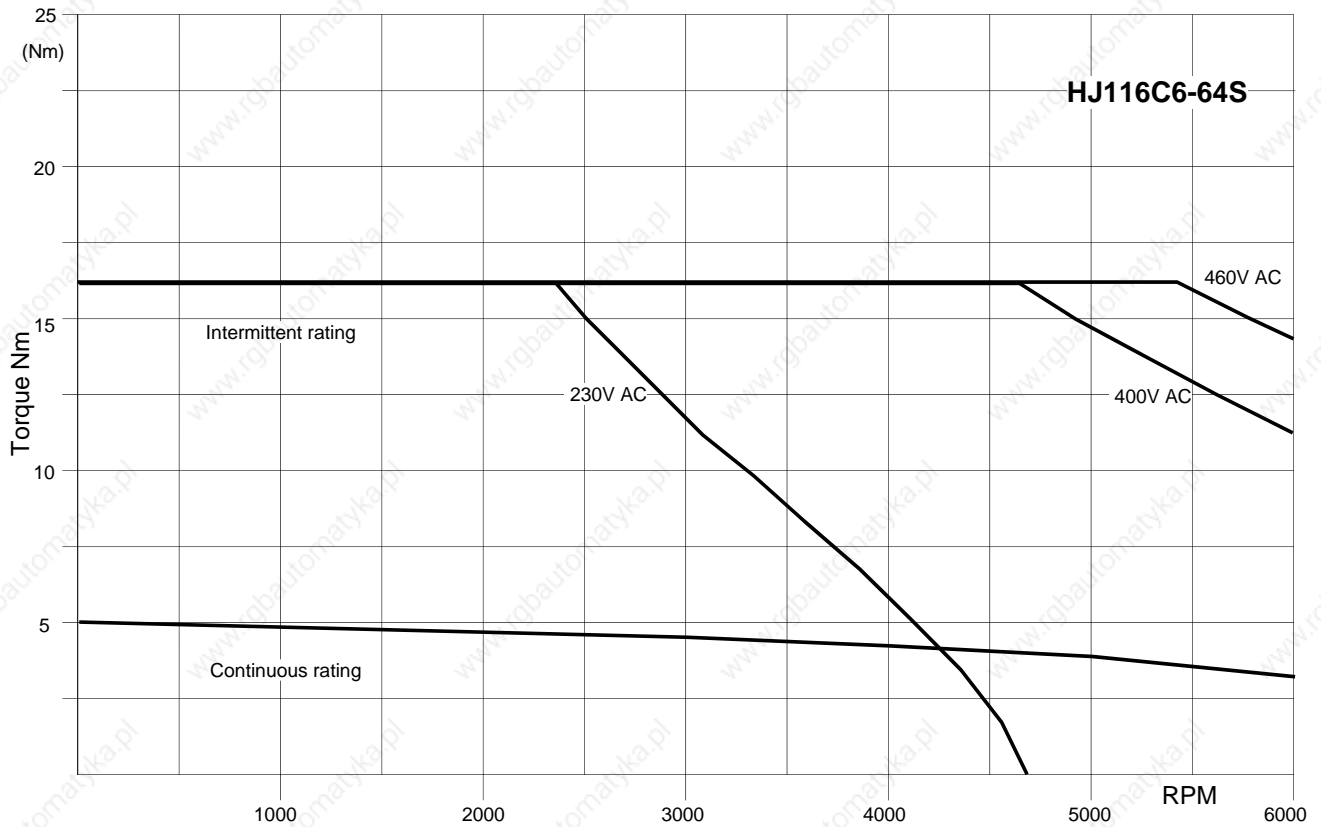

HJ116E6-88S

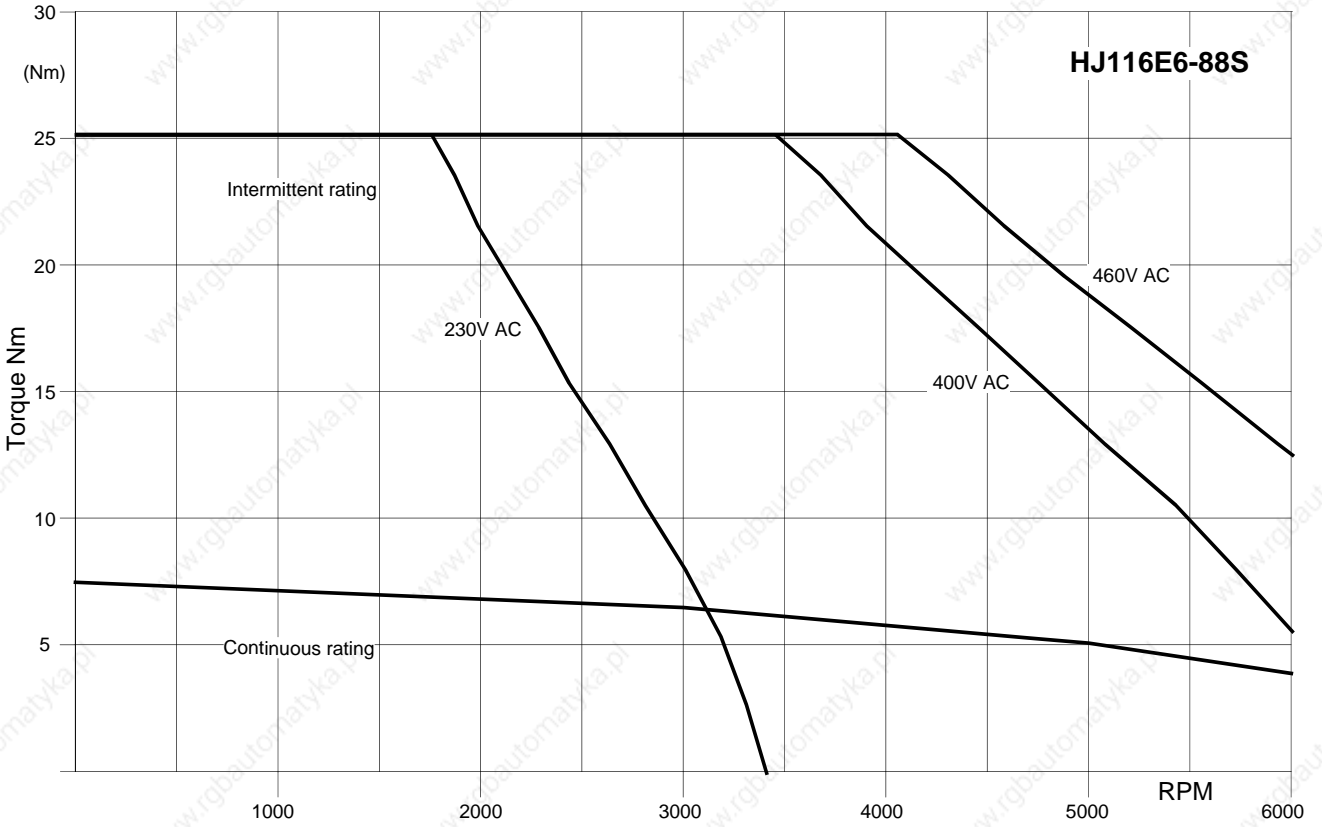

HJ155A8-88S

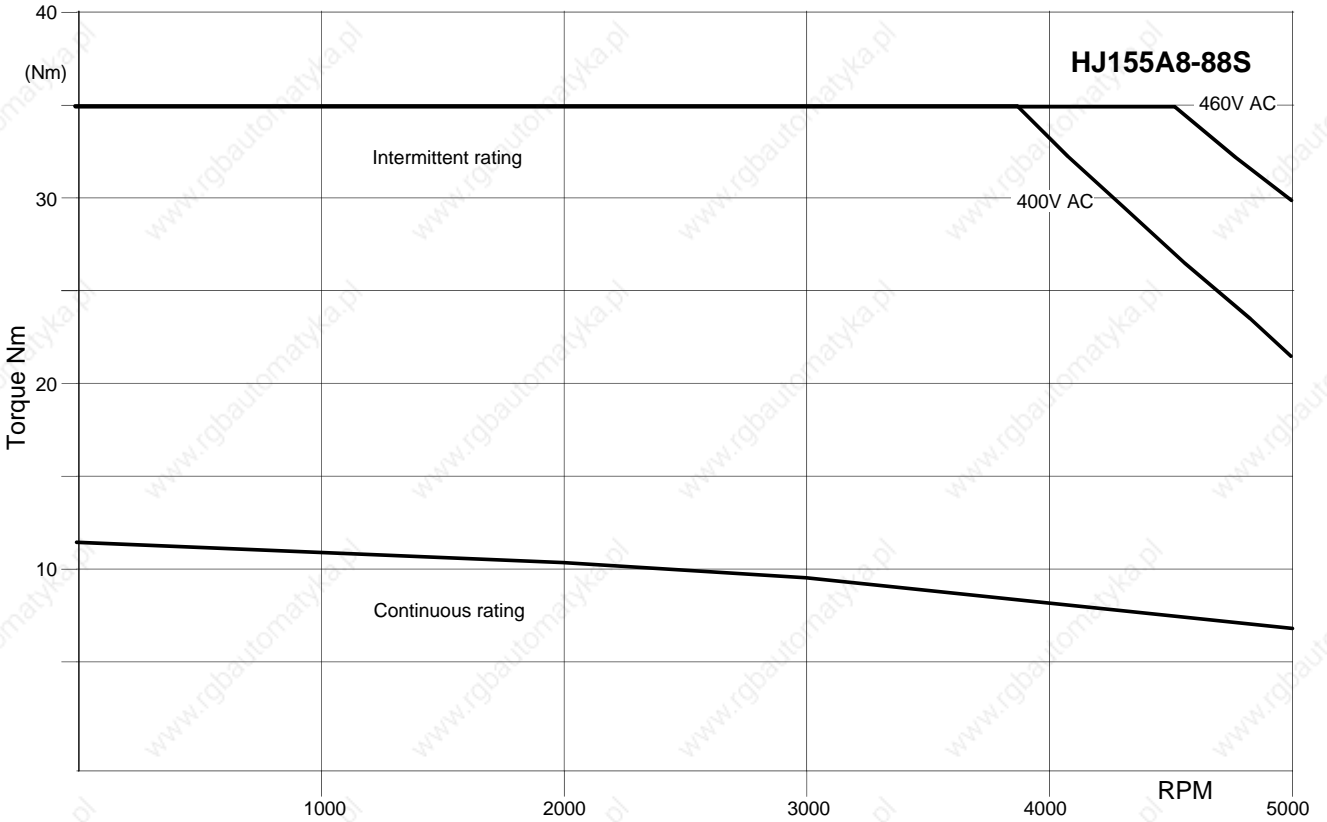

HJ155E8-130S

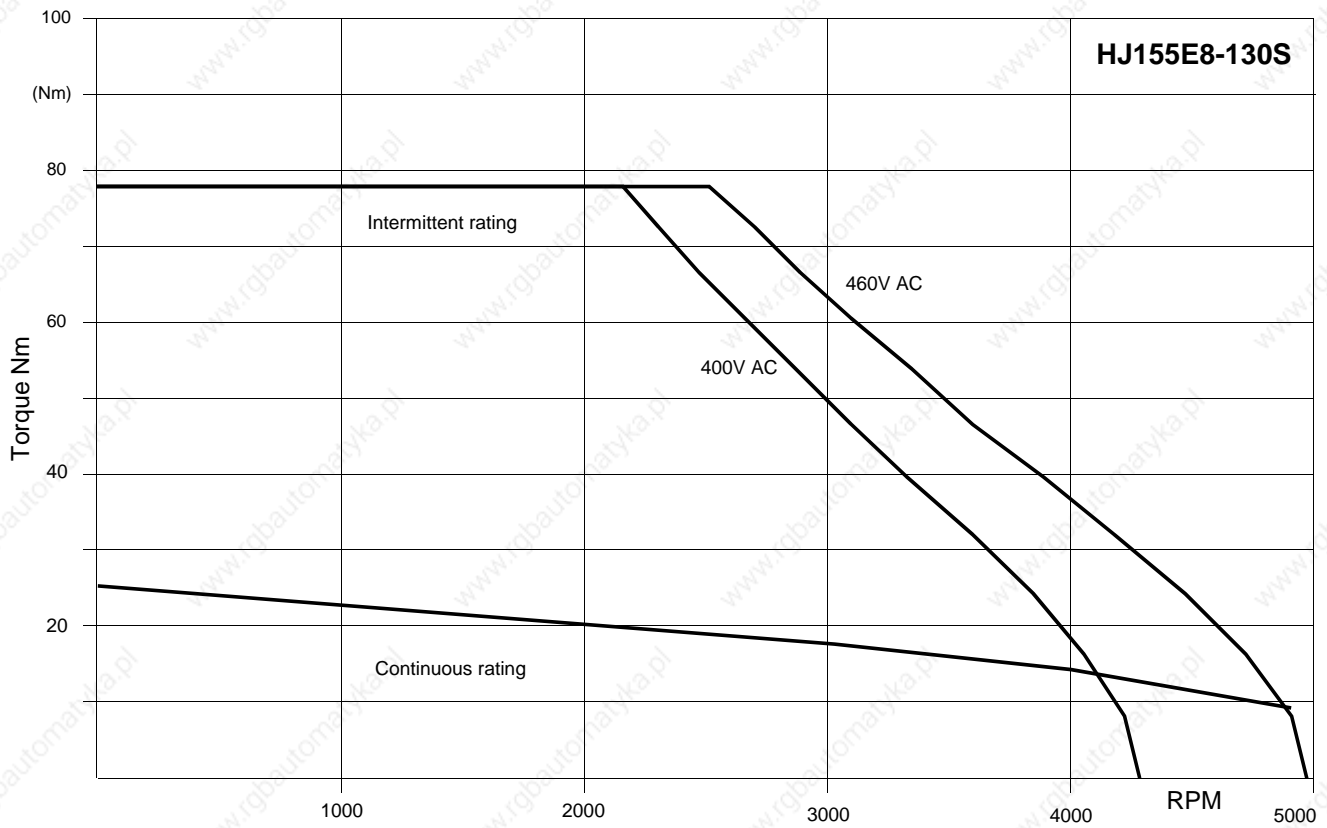

HJ155G8-135S

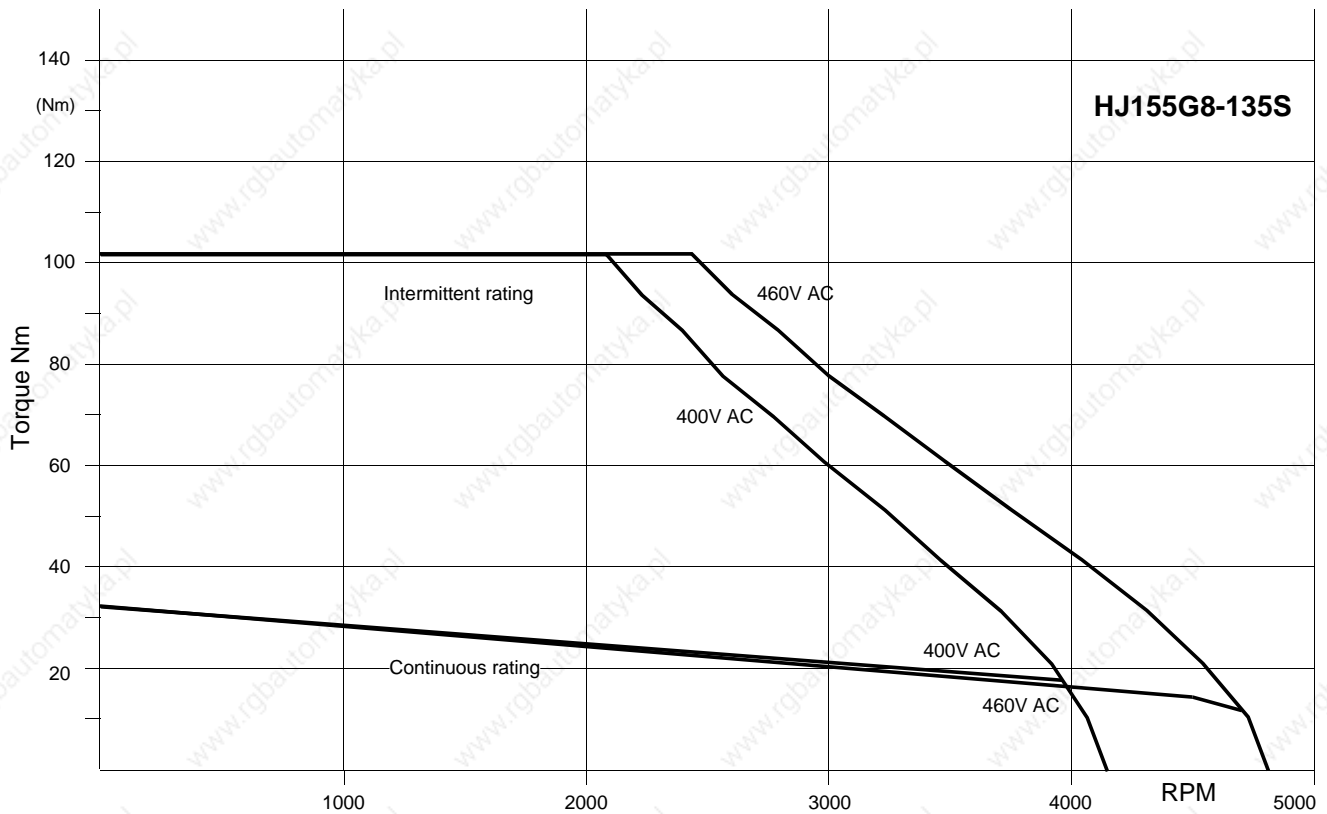

HJ155G8-135S with fan

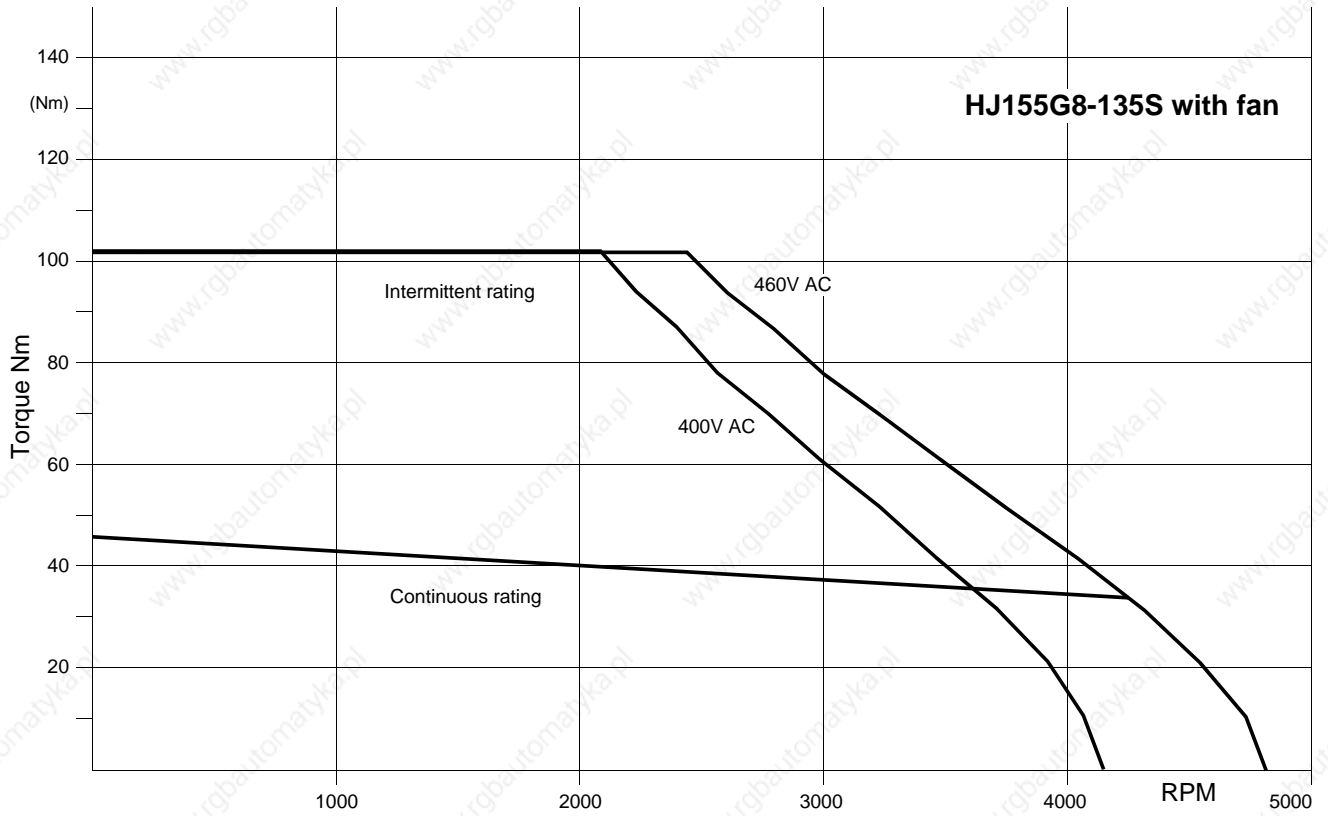

HJ190J8-150S with fan

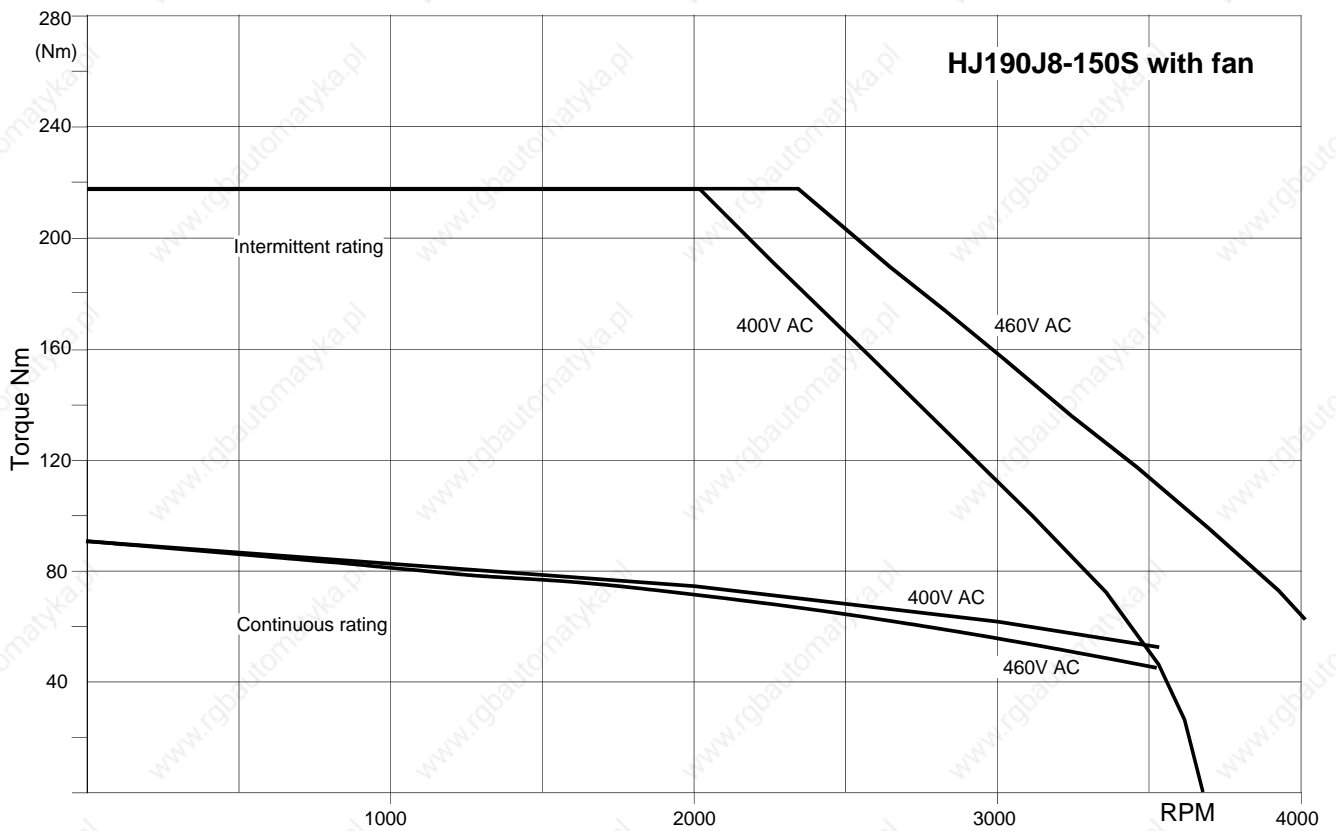

Highly dynamic synchronous servo motors HDY

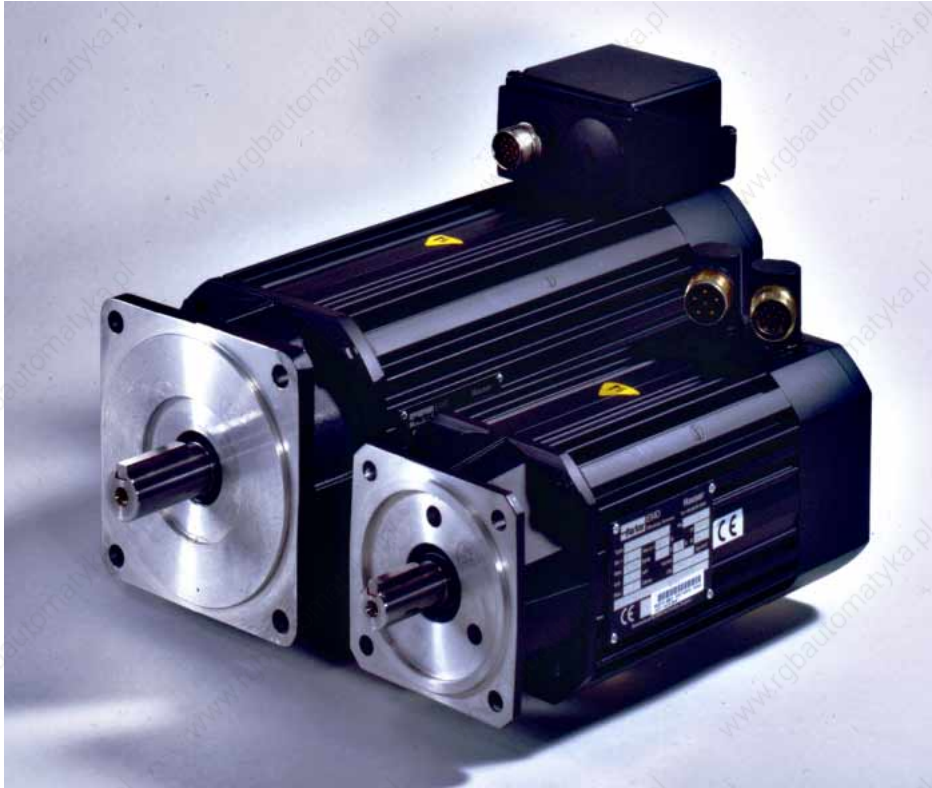

General characteristic data:

- Sinusoidal EMC.
- Painted mat black.
- Nitrile shaft seal.
- IP65 type of protection (shaft IP64).
- Insulation class F.
- Self-cooling. Max. ambient temperature: 40°C
- Any installation position.
- Standard flange: standard in acc. with DIN 42955; IEC72.
- Basic body: aluminium extruded moulding
- Flange: aluminium
- Connector sockets can be turned into almost any position (secured using a torque of 10 Nm \pm 2 Nm)
- Treble torque rating possible for up to 3s.
- Thermal switch (normally closed): switches at a coil temperature of 150°C \pm 10°.

Version:

- With spline
- Spur thread
HDY55: M3x10
HDY70: M4x12
HDY92: M5x10
HDY115: M6x15
HDY142: M8x15
- Integrated resolver.

Area of application

Highly dynamic applications in:

- packaging machines,
- shelf transport plants,
- wood machining, etc.

Options

Stationary/parking brake

The motors can be fitted with a stationary/parking brake on request. The brake is fitted in the motor housing behind the A flange, the mechanical dimensions of the motor only change in HDY55 and HDY70. The brake is fed voltage by the engine cable.

Technical data for 24V DC holding brakes:

The values for the reinforced versions are in brackets.

| Motor | Holding torque [Nm] | J [kgmm ²] | Power [A] | Switch times [ms] | |
|---------|---------------------|------------------------|-------------|-------------------|-------|
| | | | | open | close |
| HDY 55 | 1,0 | 1 | 0.29 | 25 | 20 |
| HDY 70 | 1,0 (2,0) | 2 (4) | 0.26 (0.35) | 35 | 10 |
| HDY 92 | 5,0 (10,0) | 13 (17) | 0.50 | 50 | 20 |
| HDY 115 | 10,0 (13,5) | 17 (17) | 0.50 | 50 | 20 |
| HDY 142 | 18,0 (40,0) | 200 (200) | 1.00 | 110 | 40 |

Attention: the stationary/parking brake does not permit active braking.

Sensor system

A resolver is fitted as standard in the motors.

The motors can optionally be supplied with the following sensors:

- SinCos© singleturn encoder or
- SinCos© multiturn absolute value sensor

➡ **Caution!** It's only with SinCos model SCS60 and SCM60

Do not release rear motor cover. The SinCos© is fixed by the rear motor cover.

Danger! If this is released, the motor will behave in an uncontrollable manner.

➡ By using SinCos©, the rated torque must be reduced about 10% for a correct dimensioning.

Altered dimensions with SinCos©

for HDY 55 (width and length; refer to dimensional diagram) and HDY 70 (only length):

| Motor | Length A with SinCos© [mm] | |
|-------------|----------------------------|------------|
| | Without brake | With brake |
| HDY55C4-44S | 172 | 206 |
| HDY70C4-44S | 191 | 218 |
| HDY70E4-44S | 218 | 245 |

Motor overview of HDY – motors

| Motor type | Continual stall torque M_0 Nm | Continual stall current I_0 A | Resistance Ω | Inductance μH | Entire torque constant ⁷ K_T Nm/A | Rotor inertia J kgmm ² | Weight m kg | Length ⁸ without / with brake A mm | Power voltage ac U V ac | Rated speed N_{rated} R.P.M | Rated torque M_{rated} Nm | Rated current I_{rated} A_{eff} | Rated power P_{rated} kW |
|------------|---------------------------------------|---------------------------------------|------------------------|-----------------------|--|---|-------------------|---|-------------------------------|-------------------------------------|-----------------------------------|---|----------------------------------|
| 55C4-32S | 0,4 | 1,1 | 19,0 | 17000 | 0,375 | 24 | 1,4 | 140 / 176 | 230 | 5000 | 0,35 | 1,04 | 0,18 |
| | | | | | | | | | 400 | 5000 | 0,35 | 1,04 | 0,18 |
| 70C4-44S | 1,2 | 2,3 | 4,7 | 12100 | 0,51 | 60 | 2,4 | 158 / 185 | 230 | 4400 | 1,15 | 2,30 | 0,53 |
| | | | | | | | | | 400 | 5000 | 1,10 | 2,30 | 0,58 |
| 70E4-44S | 1,8 | 3,5 | 2,6 | 7600 | 0,51 | 80 | 3,2 | 185 / 212 | 230 | 4400 | 1,75 | 3,40 | 0,81 |
| | | | | | | | | | 400 | 5000 | 1,70 | 2,30 | 0,89 |
| 92C4-44S | 1,5 | 2,9 | 4,6 | 20000 | 0,51 | 85 | 4,3 | 230 | 230 | 4400 | 1,20 | 2,40 | 0,55 |
| | | | | | | | | | 400 | 5000 | 1,16 | 2,35 | 0,61 |
| 92E4-44S | 2,2 | 4,3 | 2,8 | 14000 | 0,51 | 118 | 5,2 | 250 | 230 | 4400 | 1,85 | 3,70 | 0,85 |
| | | | | | | | | | 400 | 5000 | 1,80 | 3,60 | 0,94 |
| 115A6-64S | 3,7 | 4,9 | 2,7 | 15000 | 0,75 | 240 | 6,6 | 235 | 230 | 2800 | 3,40 | 4,30 | 1,00 |
| | | | | | | | | | 400 | 5000 | 3,10 | 4,00 | 1,60 |
| | | | | | | | | | 460 | 5000 | 3,10 | 4,00 | 1,60 |
| 115A6-88S | 3,7 | 3,6 | 5,5 | 28000 | 1,02 | 240 | 6,6 | 235 | 230 | 2000 | 3,50 | 3,20 | 0,73 |
| | | | | | | | | | 400 | 3800 | 3,20 | 3,00 | 1,27 |
| | | | | | | | | | 460 | 4400 | 3,20 | 3,00 | 1,47 |
| 115C6-88S | 6,8 | 6,6 | 1,7 | 12600 | 1,02 | 460 | 9,0 | 275 | 230 | 2000 | 6,00 | 5,80 | 1,25 |
| | | | | | | | | | 400 | 3800 | 5,20 | 5,10 | 2,07 |
| | | | | | | | | | 460 | 4400 | 4,90 | 4,90 | 2,26 |
| 115E6-88S | 9,8 | 9,5 | 1,01 | 8100 | 1,02 | 680 | 11,4 | 315 | 400 | 3800 | 7,5 | 7,3 | 3,00 |
| | | | | | | | | | 460 | 4400 | 7,0 | 6,9 | 3,23 |
| 115G6-88S | 13,0 | 12,6 | 0,63 | 6000 | 1,02 | 900 | 13,8 | 355 | 400 | 3800 | 10,0 | 9,4 | 4,00 |
| | | | | | | | | | 460 | 4400 | 9,3 | 9,3 | 4,29 |
| 142C6-88S | 11,3 | 11,0 | 0,76 | 8900 | 1,02 | 1150 | 14,0 | 295 | 400 | 3800 | 8,6 | 8,5 | 3,42 |
| | | | | | | | | | 460 | 4400 | 8,3 | 8,3 | 3,82 |
| 142G6-88S | 21,0 | 20,0 | 0,29 | 4000 | 1,02 | 2200 | 21,0 | 375 | 400 | 3800 | 16,0 | 15,6 | 6,36 |
| | | | | | | | | | 460 | 4400 | 15,5 | 15,0 | 7,14 |

The general motor values have been determined in accordance with:
the British standard BS4999 or the international Standard IEC34 • Overtemperature: 110K • Tolerance: $\pm 10\%$.
Assumed is that the air can circulate freely to all sides (mounting distance approx. 30% of the edge length)

When the rated data was determined, the following tolerances were also taken into consideration:

- 10% mains undervoltage.
- 17V voltage drop in the final stage.
- 10% voltage control reserve for controlled operation under rated conditions.

The following were not taken into consideration:

- Tolerance ($\pm 10\%$) of torque constant, motor inductivity and motor resistance.
- Temperature dependency of torque constants and motor resistance.

⁷ To determine torque: torque = 0,71 * entire torque constant * transverse current (see User Guide COMPAX)

⁸ Look at the dimensional drawings on the next page. HDY55 - and HDY70 - motors: the dimension A is only valid for motors with resolver. For motors with SinCos you will find the length A on page 1.

Dimensional drawings

HDY55C4-32S

with resolver

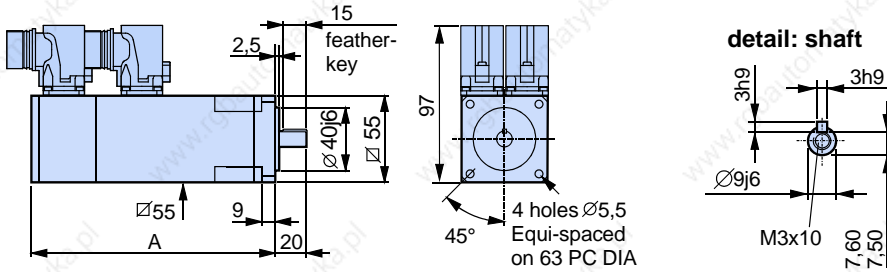

with SinCos©

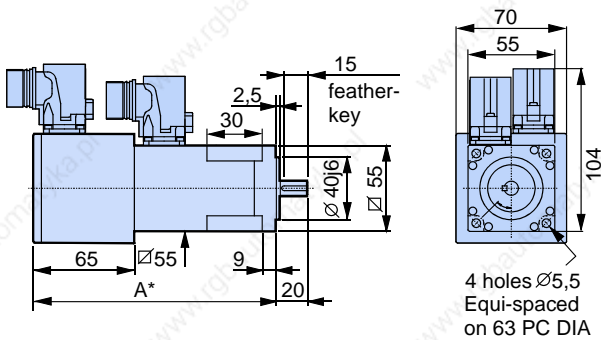

HDY70C4-44S / HDY70E4-44S

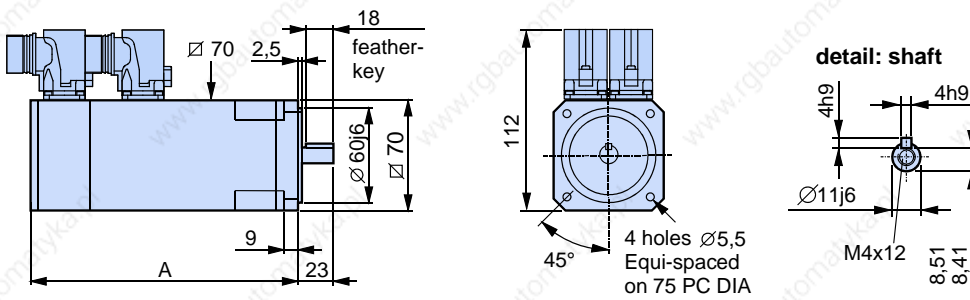

HDY92C4-44S / HDY92E4-44S

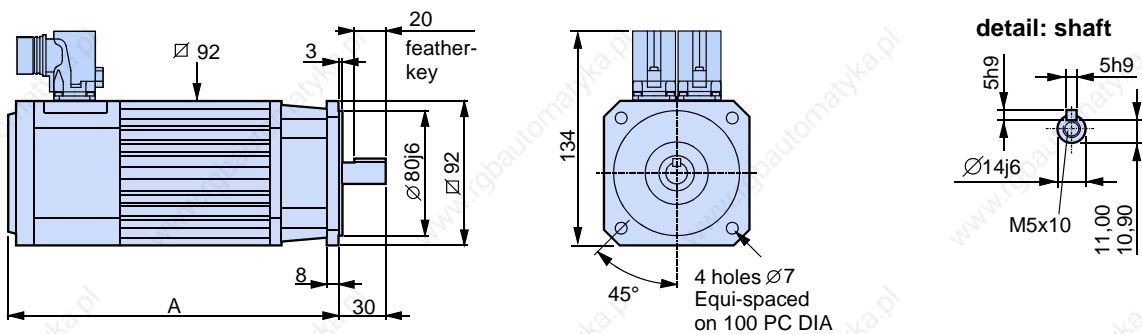

You can find the CAD-files of the dimensional drawings in the "dxf and "mi" format on our homepage.

HDY115A6-64S / HDY115A6-88S / HDY115C6-88S / HDY115E6-88S / HDY115G6-88S

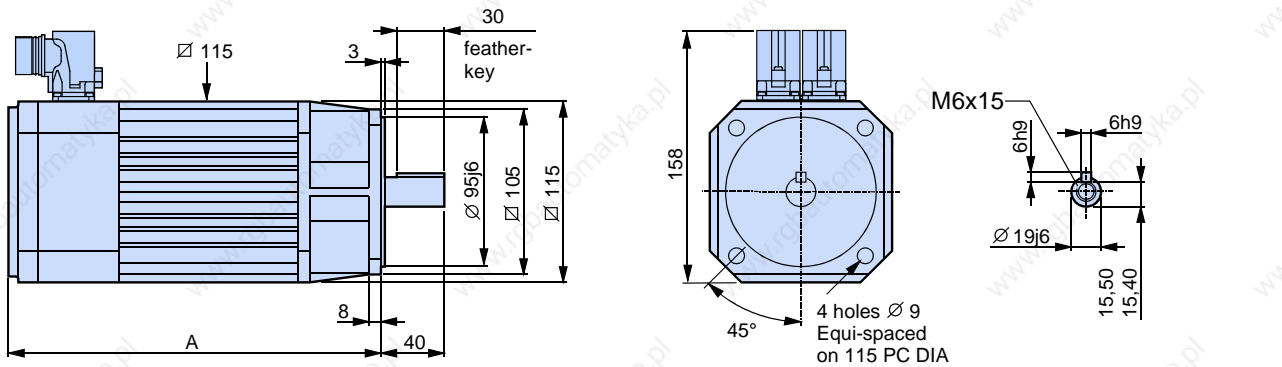

HDY142C6-88S / HDY142G6-88S

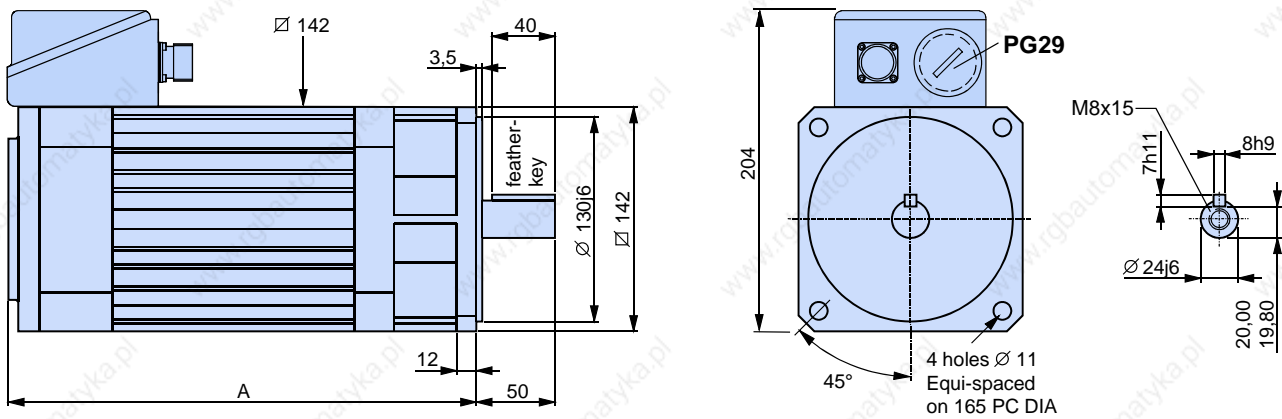

You can find the CAD-files of the dimensional drawings in the "dxf" and "mi" format on our homepage.

Motor characteristics curves

HDY55C4-32S

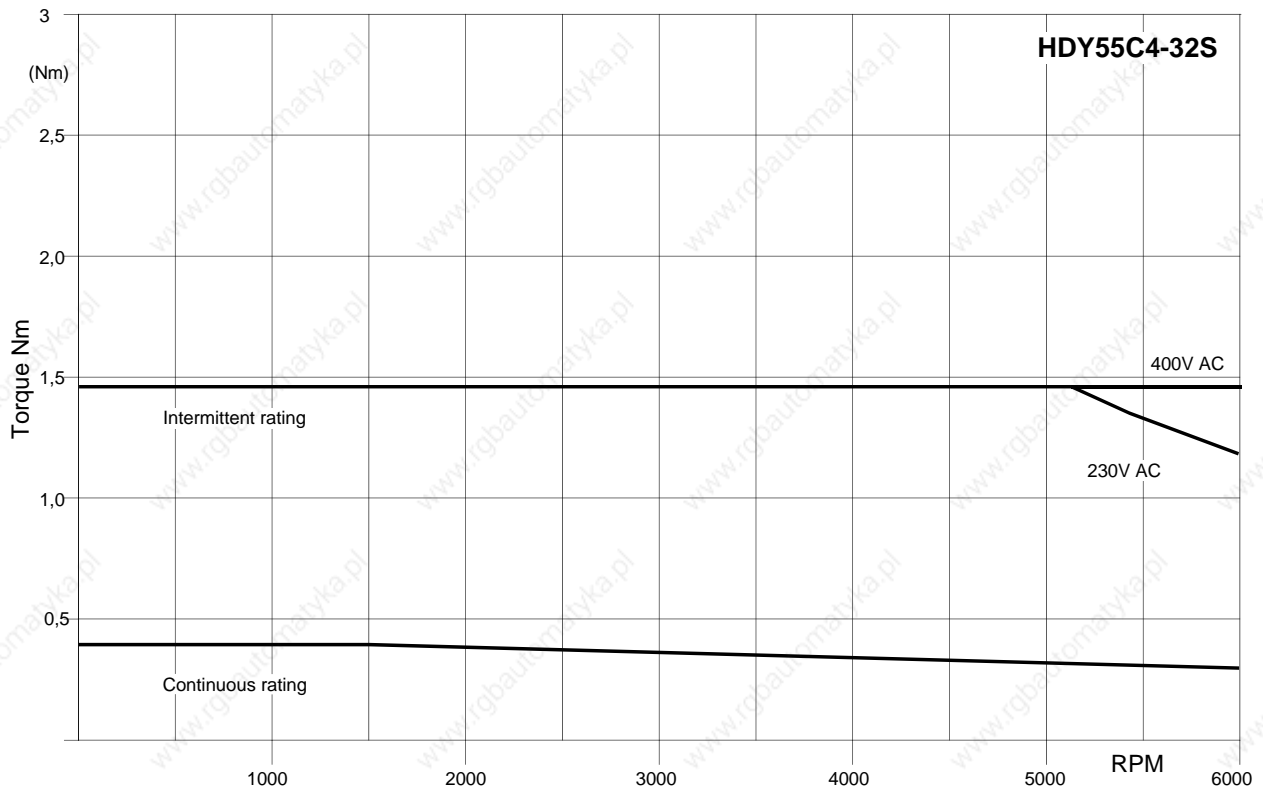

HDY70C4-44S

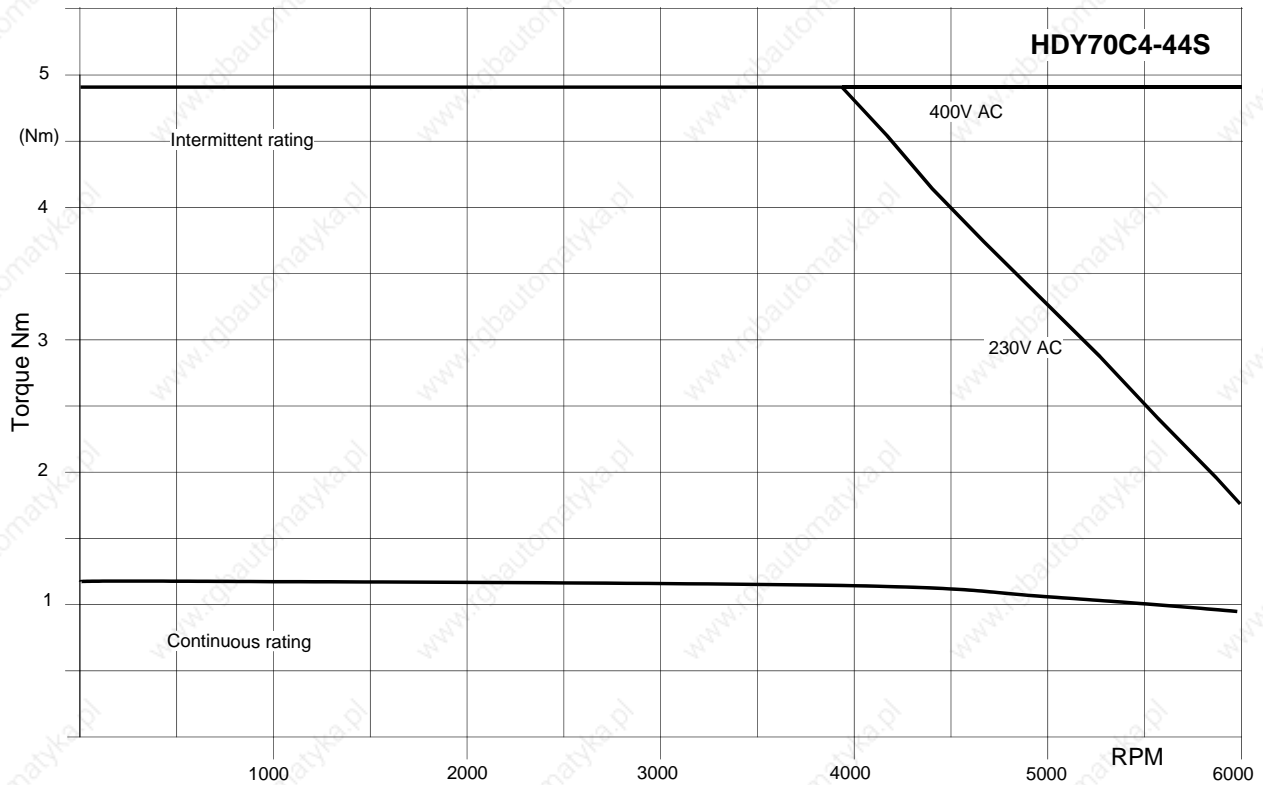

HDY70E4-44S

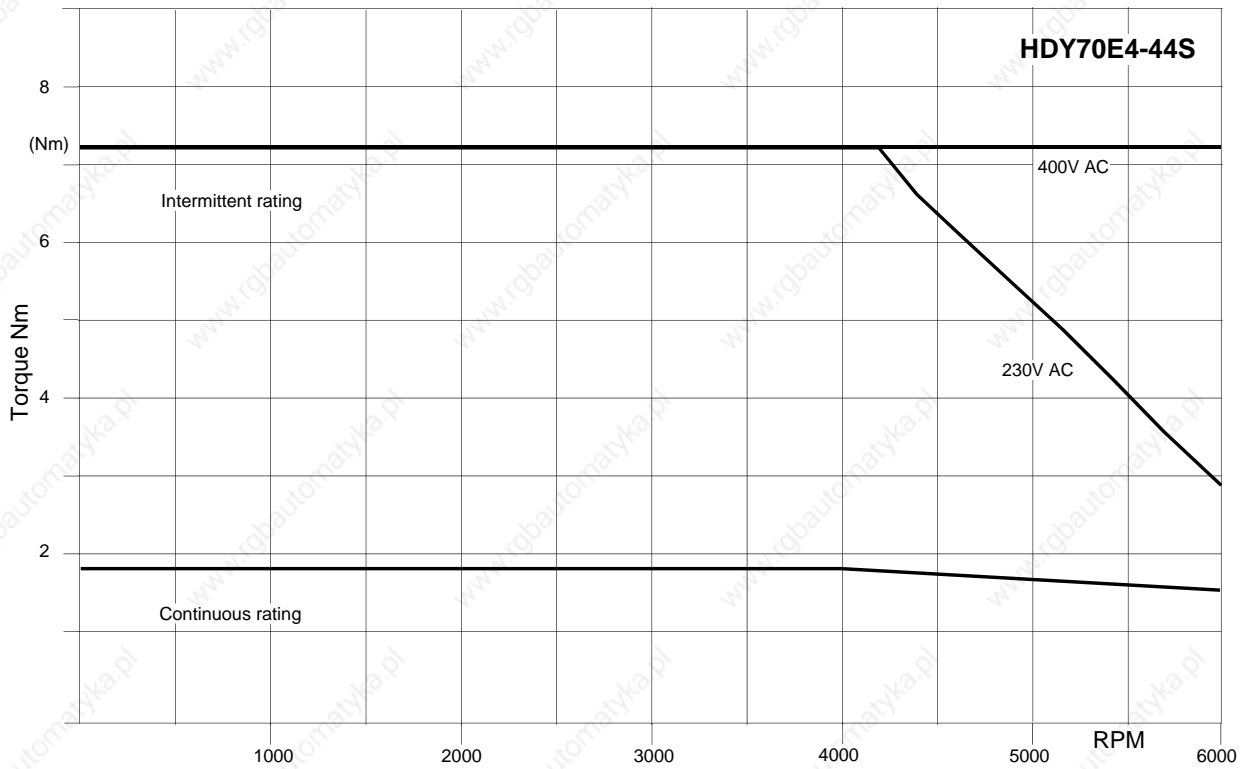

HDY92C4-44S

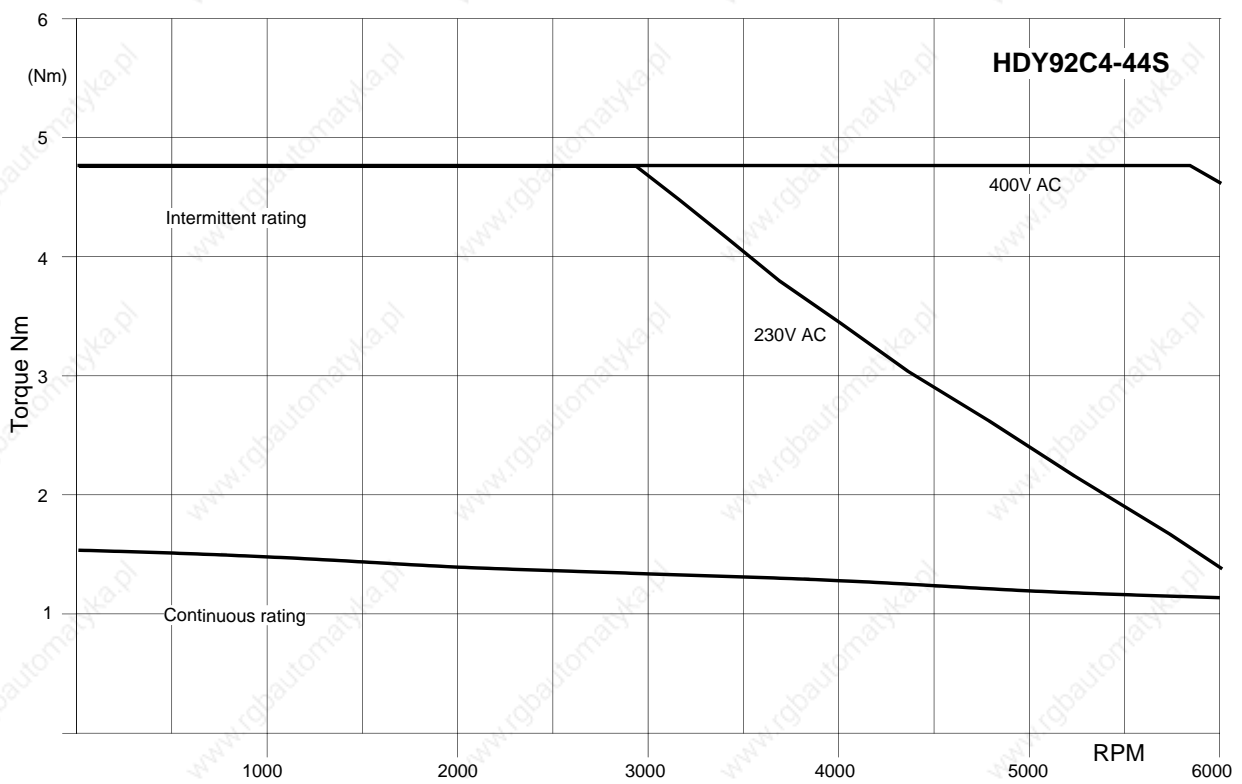

HDY92E4-44S

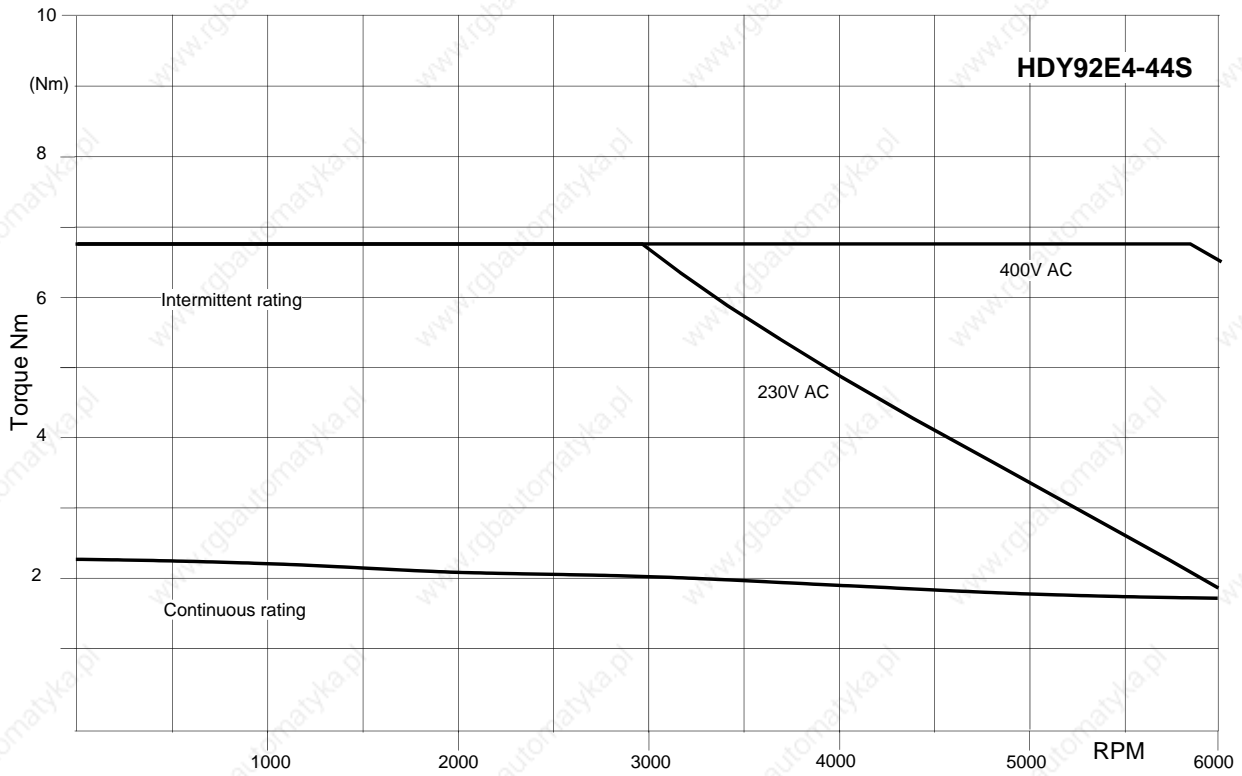

HDY115A6-64S

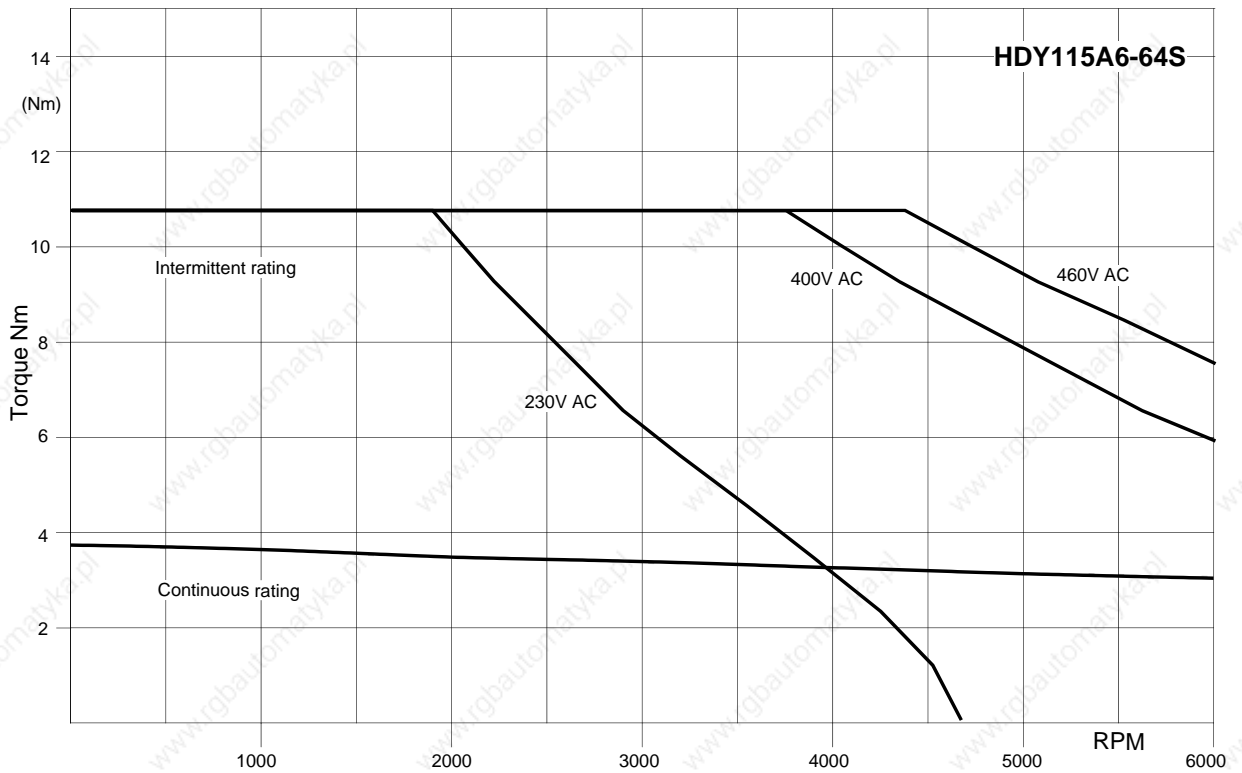

HDY115A6-88S

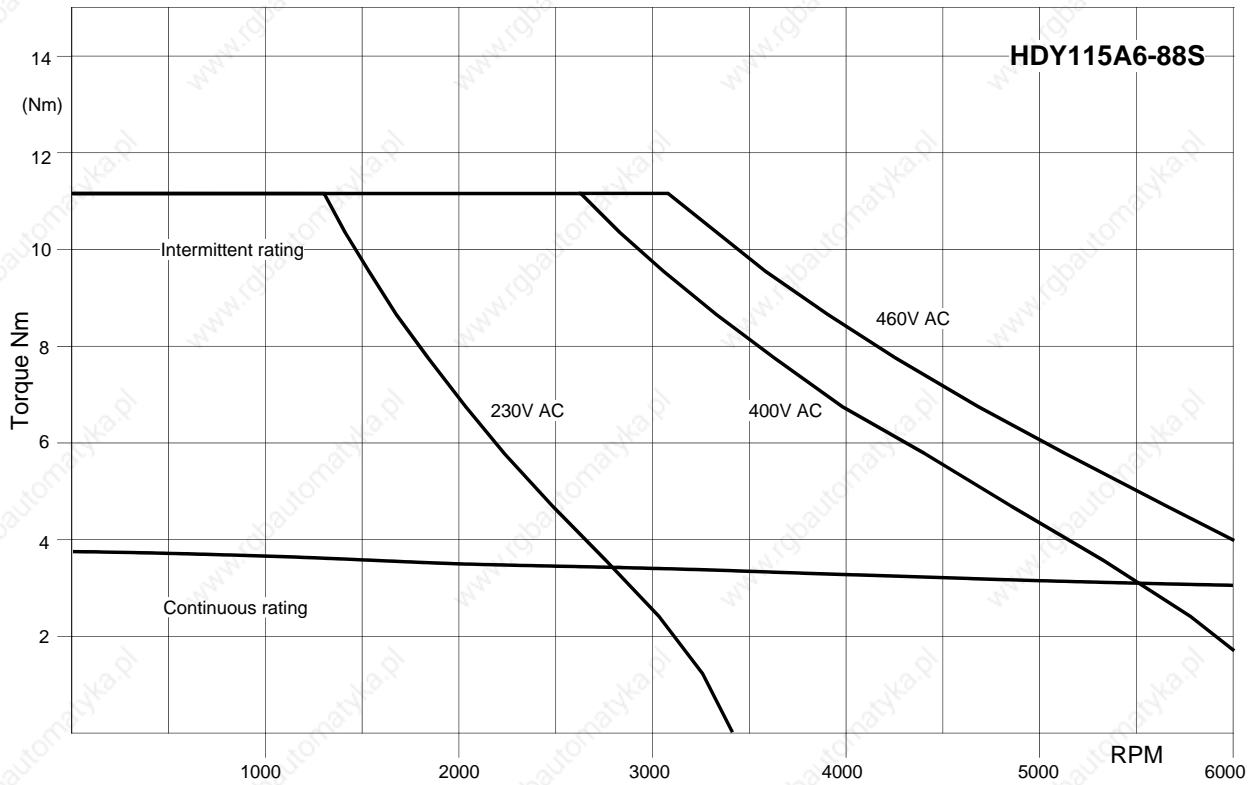

HDY115C6-88S

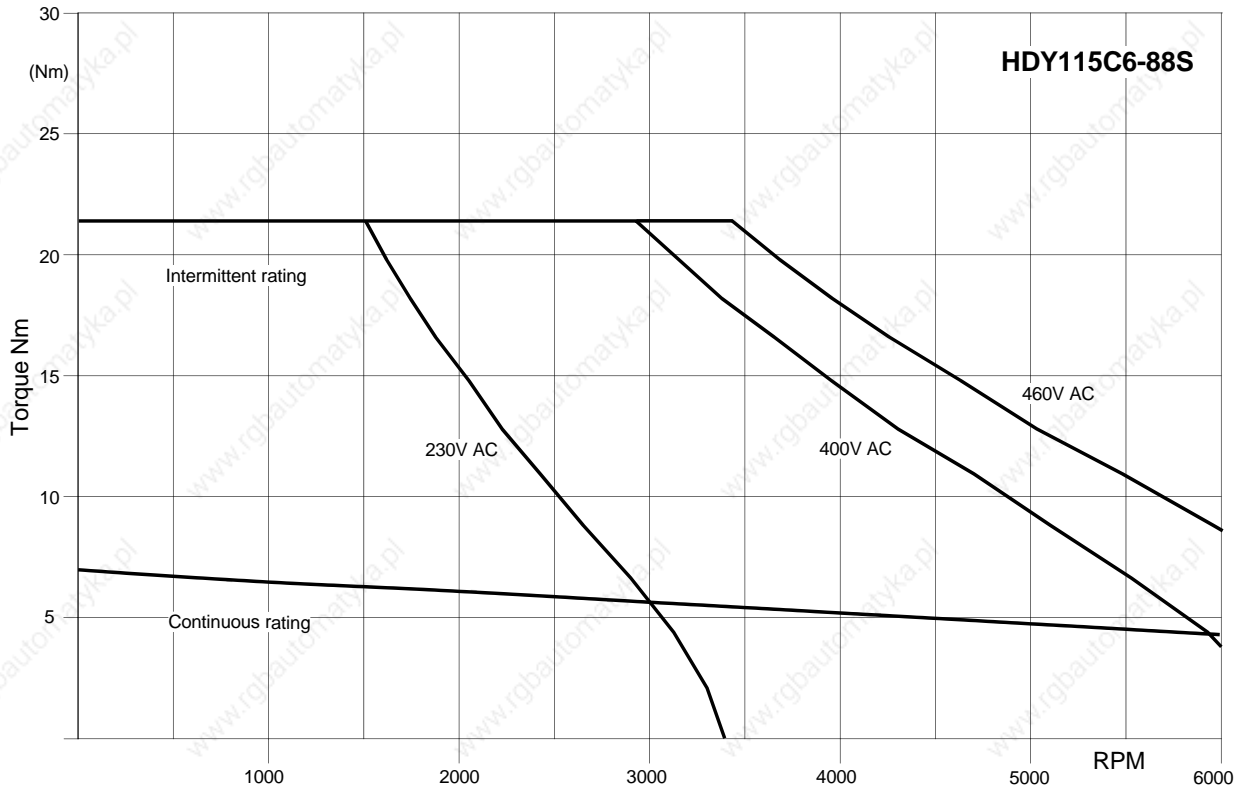

HDY115E6-88S

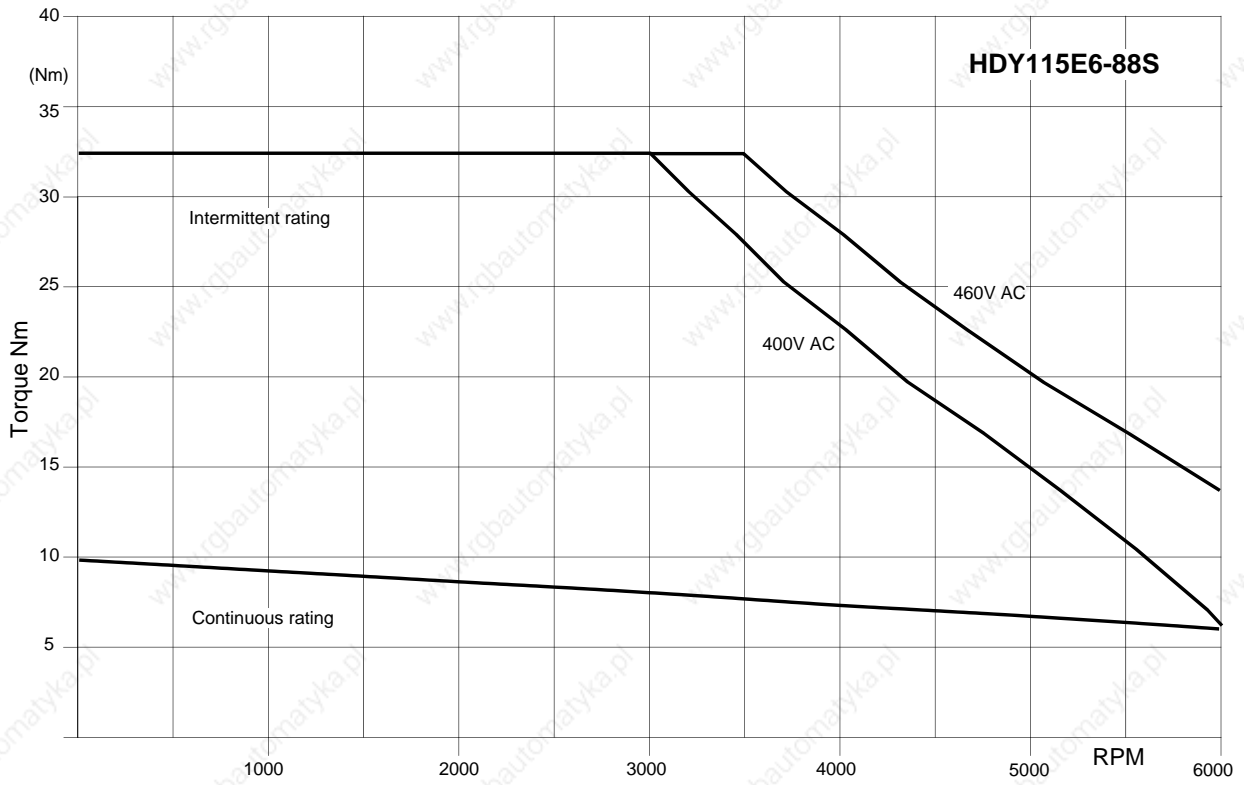

HDY115G6-88S

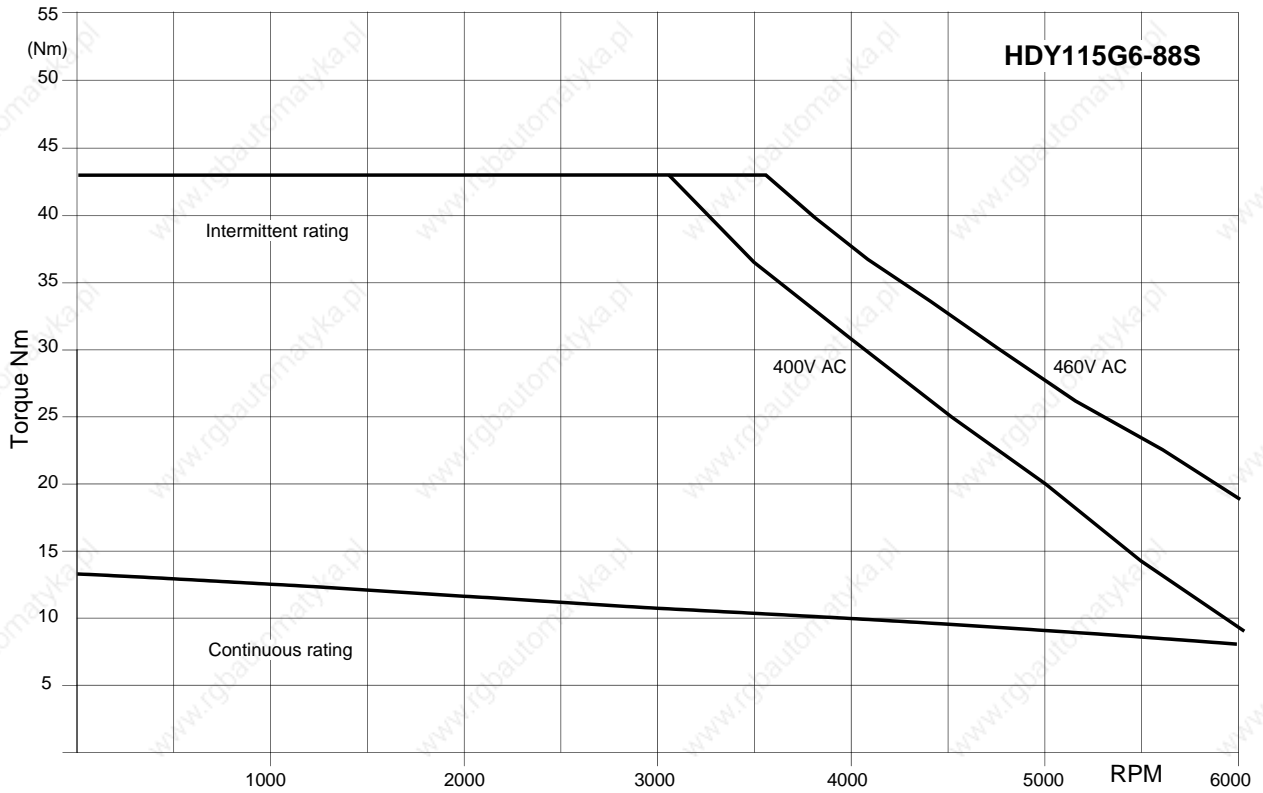

HDY142C6-88S

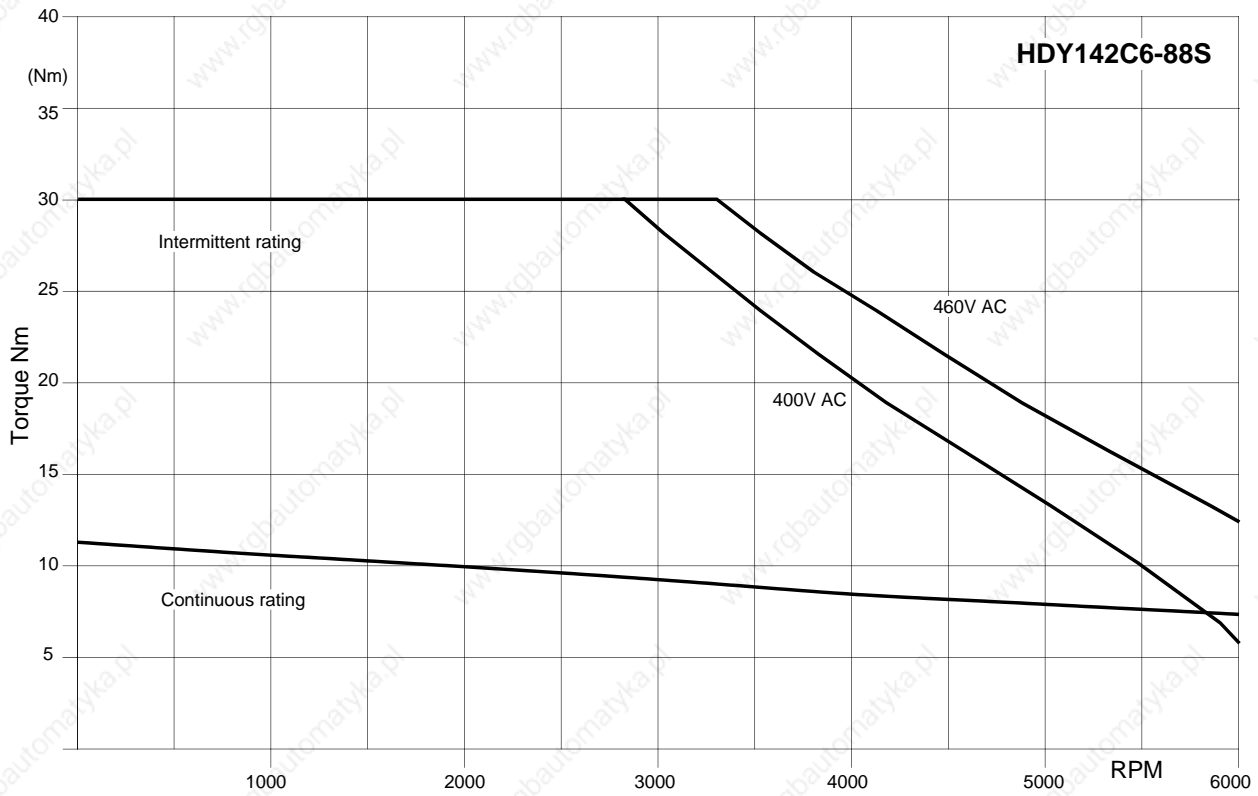

HDY142G6-88S

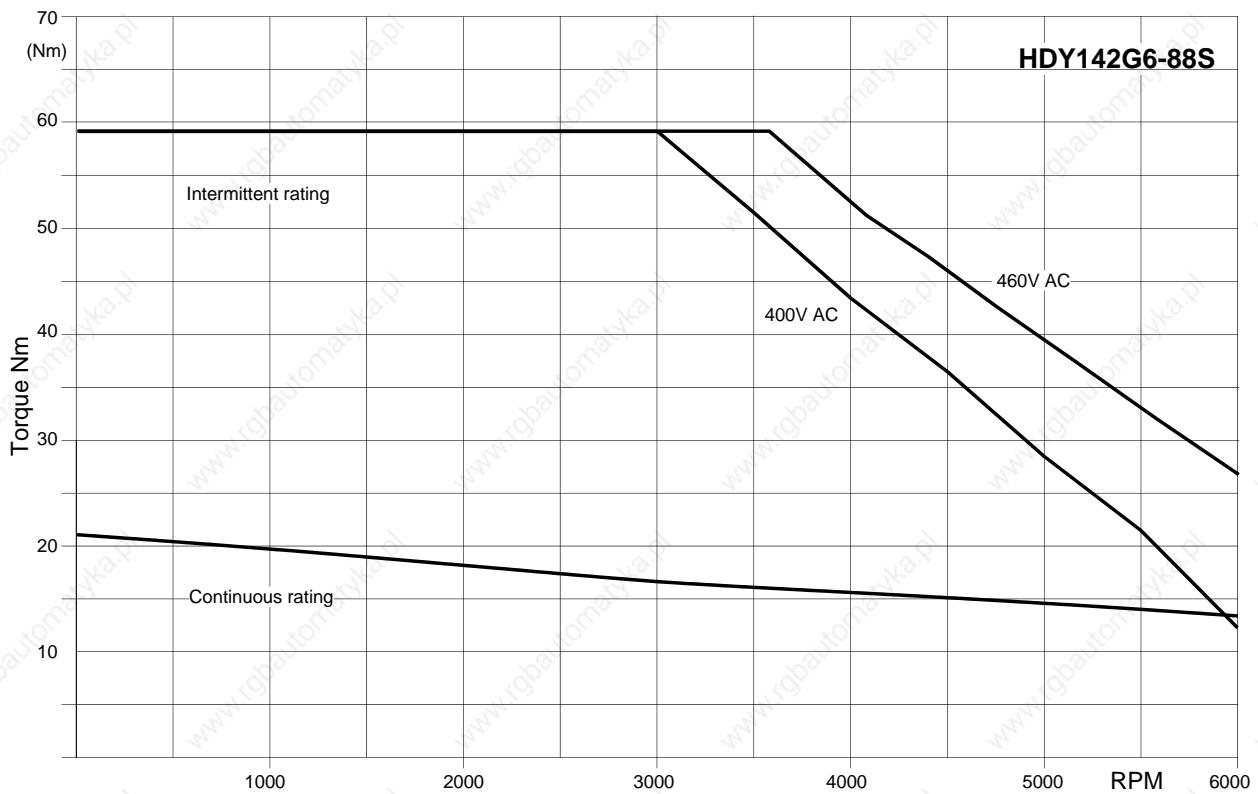

Connecting cable to motor

| | | Resolver cable | Sensor cable (SinCos®) | Motor cable | | | | |
|-----------------|-------------------------------|--------------------------|--------------------------|---|--------------------------------|---|------------------------------|-------------------------------|
| | | | | With connectors: HJ96, HJ116, HDY55, HDY70, HDY92, HDY115 | | With terminal boxes: HJ155, HJ190, HDY142 | | |
| | | | | 1.5mm ² up to 13.8A | 2.5mm ² up to 18.9A | 2.5mm ² up to 18.9A | 6mm ² up to 32.3A | 10mm ² up to 47.3A |
| Standard cable | Cable sheathed | REK32/.. | GBK16/.. | MOK42/.. | MOK43/.. | MOK21/.. | MOK11/.. | MOK46/.. |
| | Connector set | 085-301312 800-030031 | 085-301317 800-030031 | 085-301306 | 085-301306 | 125-518162 125-216800 | 125-518211 125-217000 | 125-518200 |
| | Cable | 102-150200 | 102-150210 | 102-508896 | 102-508902 | 102-508902 | 102-150030 | 102-150040 |
| | Cable data in mm ⁹ | 8,0/80/120 | 7,5/38/113 | 10,7/107/107 | 13,7/137/137 | 13,7/137/137 | 16,5/124/124 | 22,5/168/168 |
| High-flex cable | Cable sheathed | REK33/.. | GBK17/.. | MOK44/.. | MOK45/.. | MOK14/.. | MOK11/.. | MOK46/.. |
| | Connector set | 085-301312 800-030031 | 085-301317 800-030031 | 085-301306 | 085-301306 | 125-518162 125-216800 | 125-518211 125-217000 | 125-518200 |
| | Cable | 102-000030 | - | 102-000020 | 102-000010 | 102-000010 | 102-150030 | 102-150040 |
| | Cable data in mm | 8,2/61,5/61,5 | 8,0/40/64 | 9,2/69/69 | 11/82,5/82,5 | 11/82,5/82,5 | 16,5/124/124 | 22,5/168/168 |

Resolver cable for HJ and HDY motors

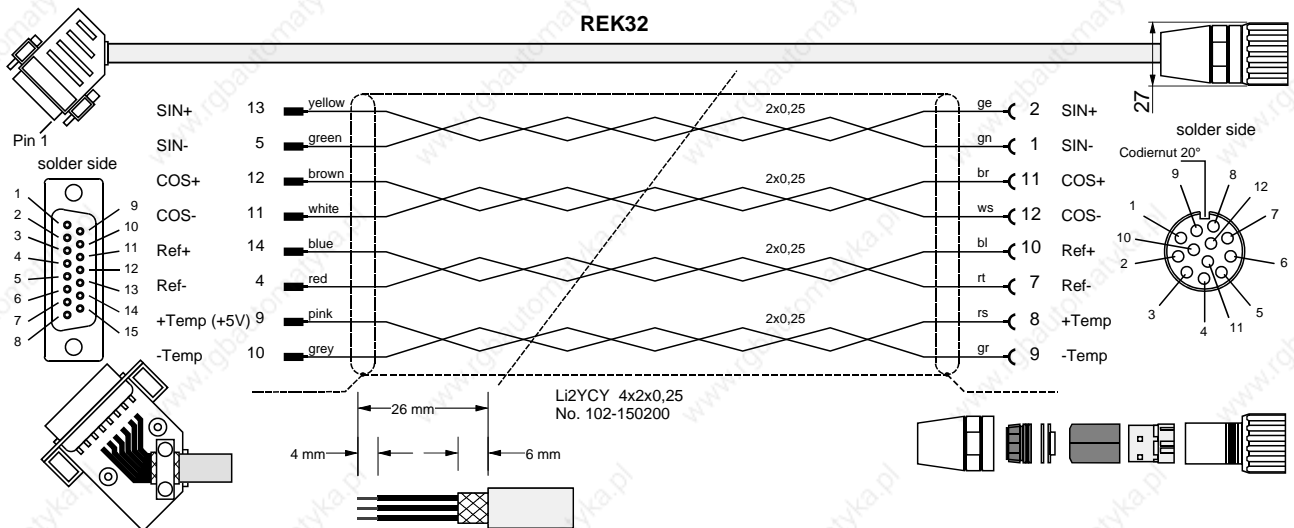

➡ In HJ – motors, ensure that the thermal sensor has the correct terminal arrangement.

Version in high-flex: REK33 (same layout)

Packaging

Packaging of motor in accordance with connector manufacturer's specification

Packaging of device

- Strip 26mm sheathing off.
- Cut sheath down to 6 mm.
- Strip 4mm of insulation of ends and coat in tin.
- Place sheath over large area of housing (e.g. fold sheath over outer cover and fasten down by relieving tension).

*⁹ Cable diameter / minimum bending radius (static) / minimum bending radius (dynamic)

Motor cable for HJ and HDY – motors

MOK42 (max. 13,8A)

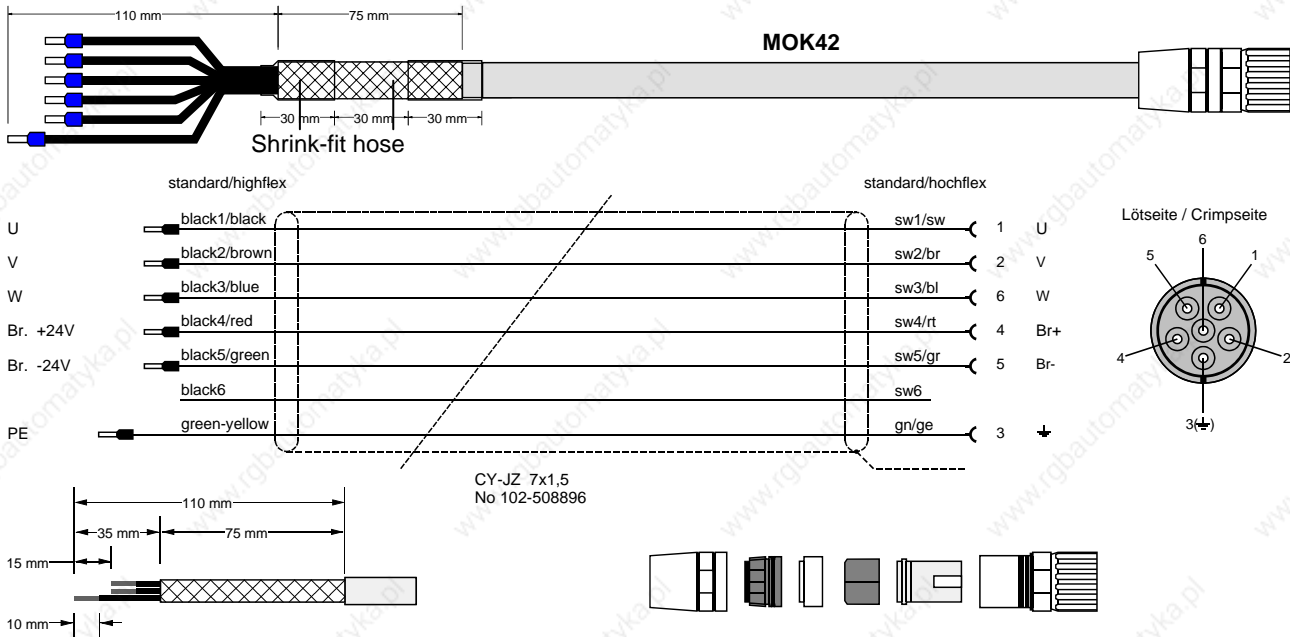

Version in high-flex: MOK44 (same layout)

MOK43/.. (max. 18.9A): HJ (version in high-flex: MOK45)

Layout corresponds to MOK42, however motor lines in 2.5 mm²

Packaging

Packaging of motor in accordance with connector manufacturer's specification

Contacts for 1.5 mm² and 2.5 mm² are supplied with the connector set.

Packaging of device

Material:

- 6 x crimping sleeves.
- 6 cm shrink-fit hose.

Procedure:

- Strip 110 mm sheathing off cable.
- Cut down sheath to approx. 35 mm, loosen,
- fold back over outer cover (approx. 75 mm) and stick with insulating tape.
- Shorten sw1,sw2,sw3,sw4,sw5 approx. 15 mm ; (gn/ge approx. 15 mm longer); cut down sw6.
- Attach 2 x approx. 30 mm shrink-fit hose (sticky).
- Strip 10 mm of insulation of ends of wires and secure with crimping sleeve 1.5.

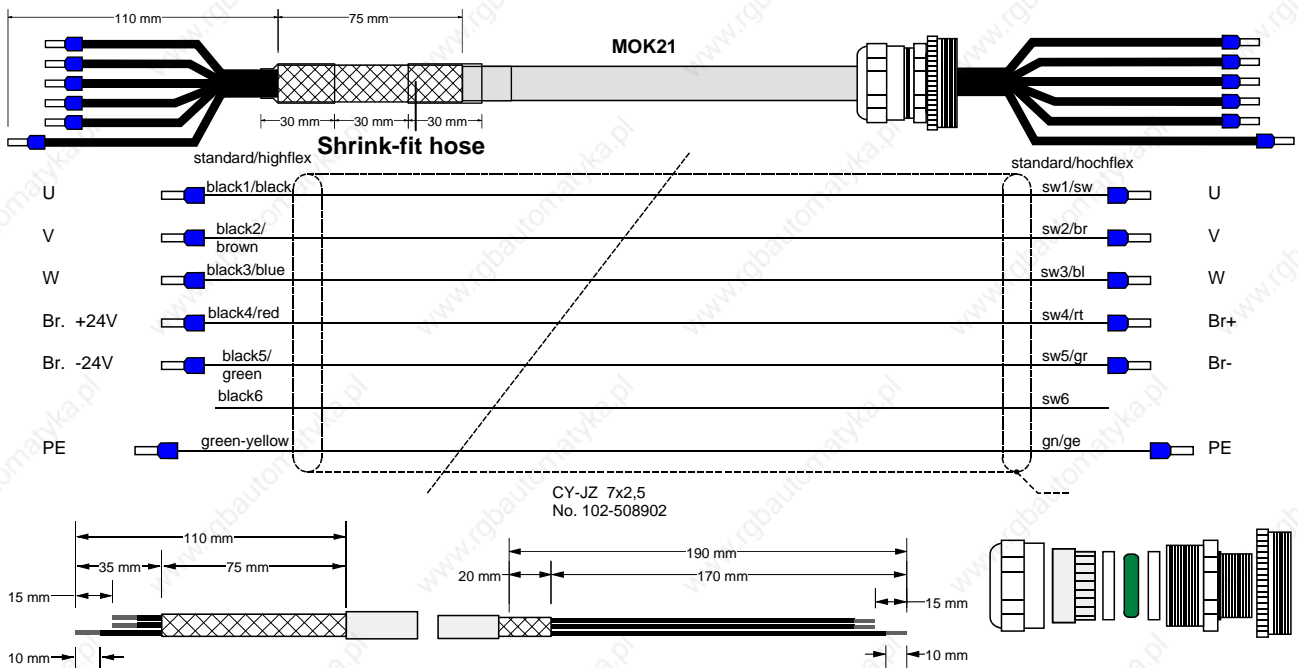
MOK21 (max. 18,9A)**Version in high-flex: MOK14 (same layout)****MOK11 (max. 32.3A) in high-flex (same layout to MOK21, however in 6 mm²)****MOK46 (max. 47.3A) in high-flex (same layout to MOK21, however in 10mm²)****Packaging****Packaging of device****Material:**

- 6 x crimping sleeves.
- 6 cm shrink-fit hose.

Procedure:

- Strip 110 mm sheathing off cable.
- Cut sheath down to approx. 35 mm, loosen,
- fold back over outer cover (approx. 75 mm) and stick with insulating tape.
- Shorten sw1,sw2,sw3,sw4,sw5 ca. 15 mm (gn/ge approx. 15 mm longer) cut down sw6.
- Attach 2 x approx. 30 mm shrink-fit hose (sticky).
- Strip 10 mm of insulation off ends of wires and secure with crimping sleeves 2.5.

Packaging of motor in accordance with manufacturer's specification

- Strip 190 mm sheathing of cable.
- Cut sheath down to approx. 170 mm, stick remaining 20 mm with insulating tape.
- Shorten sw1,sw2,sw3,sw4,sw5 by approx. 15 mm (gn/ge approx. 15 mm longer) cut down sw6.
- Strip 10 mm of insulation of ends of wires and secure with crimping sleeves 2.5.

SinCos® cable for HJ and HDY motors

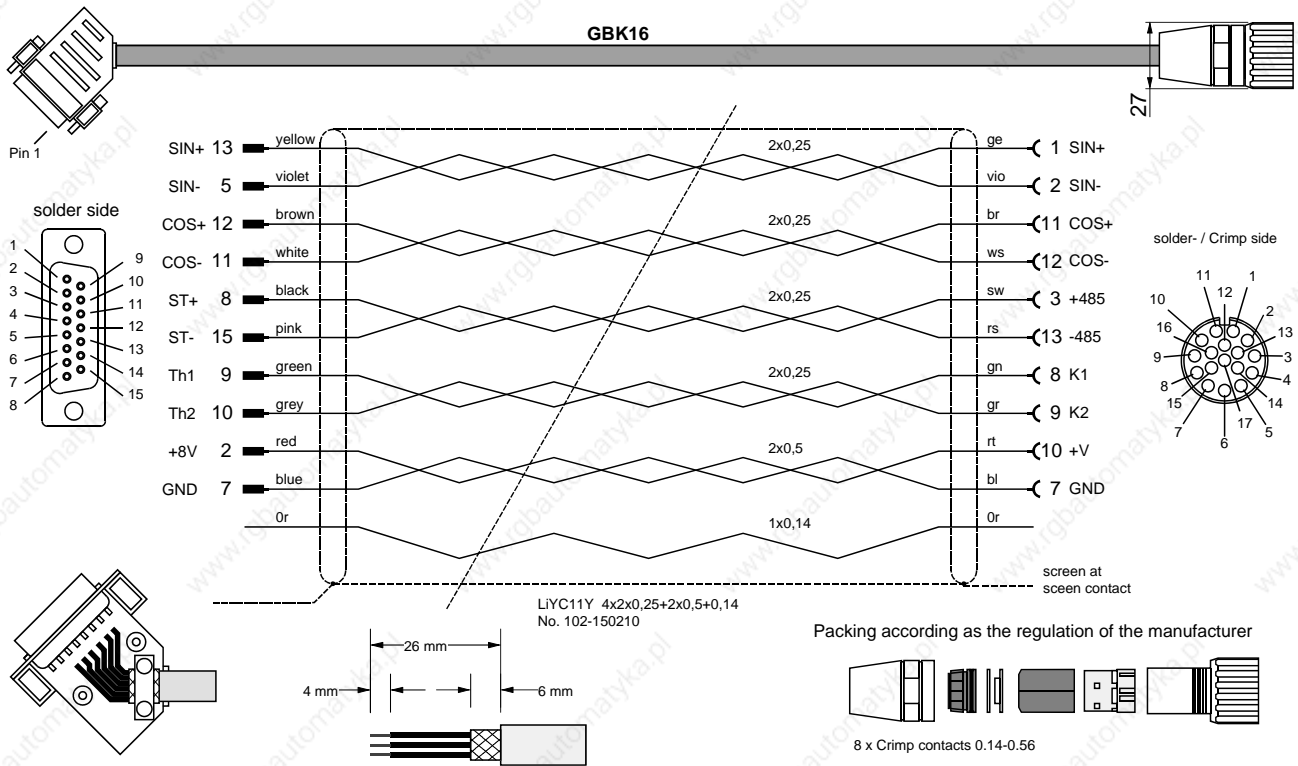

Version in high-flex: GBK17 (same layout)

Packaging

Packaging of motor in accordance with connector manufacturer's specification

Packaging of device

- Strip 26mm sheathing off.
- Cut sheath down to 6 mm.
- Strip 4mm of insulation of ends and coat in tin.
- Place sheath over large area of housing (e.g. fold sheath over outer cover and fasten down by relieving tension).

Order code cables

Motor cable, resolver cable, encoder cable

Motor cable for HJ96, HJ116, HDY55, HDY70, HDY92, HDY115

| Motor cable 1,5mm ² standard (<13,8A) | M | O | K | 4 | 2 |
|---|---|---|---|---|---|
| Motor cable 1,5mm ² highly flexible (<13,8A) | M | O | K | 4 | 4 |
| Motor cable 2,5mm ² standard (<18,9A) | M | O | K | 4 | 3 |
| Motor cable 2,5mm ² highly flexible (<18,9A) | M | O | K | 4 | 5 |

Motor cable for HJ155, HJ190, HDY142

| | | | | | |
|---|---|---|---|---|---|
| Motor cable 2,5mm ² standard (<18,9A) | M | O | K | 2 | 1 |
| Motor cable 2,5mm ² highly flexible (<18,9A) | M | O | K | 1 | 4 |

Motor cable for HJ155, HJ190, HDY142

| | | | | | |
|--|---|---|---|---|---|
| Motor cable 6mm ² highly flexible (= standard) (<32,3A) | M | O | K | 1 | 1 |
|--|---|---|---|---|---|

Motor cable for HJ155, HJ190, HDY142

| | | | | | |
|---|---|---|---|---|---|
| Motor cable 10mm ² highly flexible (= standard) (<47,3A) | M | O | K | 4 | 6 |
|---|---|---|---|---|---|

Resolver cable (identical for all motors)

| | | | | | |
|--------------------------------|---|---|---|---|---|
| Resolver cable standard | R | E | K | 3 | 2 |
| Resolver cable highly flexible | R | E | K | 3 | 3 |

Encoder cable (identical for all motors)

| | | | | | |
|---|---|---|---|---|---|
| Encoder cable (SInCos©) standard | G | B | K | 1 | 6 |
| Encoder cable (SInCos©) highly flexible | G | B | K | 1 | 7 |

Length of ready-made cables see following table **Example:** requested length 25m 0 9

| Length [m] | 1,0 | 2,5 | 5,0 | 7,5 | 10,0 | 12,5 | 15,0 | 20,0 | 25,0 | 30,0 | 35,0 | 40,0 | 45,0 | 50,0 |
|------------|-----|-----|-----|-----|------|------|------|------|------|------|------|------|------|------|
| Code | 01 | 02 | 03 | 04 | 05 | 06 | 07 | 08 | 09 | 10 | 11 | 12 | 13 | 14 |



Parker Hannifin GmbH
EMD HAUSER
Robert-Bosch-Str. 22
D-77656 Offenburg, Germany
Tel.: +49 (0)781 509-0
Fax: +49 (0)781 509-176
Website: www.parker-emd.com
e-mail: vertrieb@parker-emd.com

Parker Hannifin plc
Electromechanical Division
21 Balena Close
Poole, Dorset. BH17 7DX UK
Tel.: +44 (0)1202 69 9000
Fax: +44 (0)1202 69 5750
Website: www.parker-emd.com
e-mail: sales@parker-emd.com