

Automation PC 620

The modular, fan-free industrial PC



Table of contents

System characteristics	914
Typical topologies	918
Product overview	922
Product data sheets	926
Display links	932
Dimensions	938

System characteristics

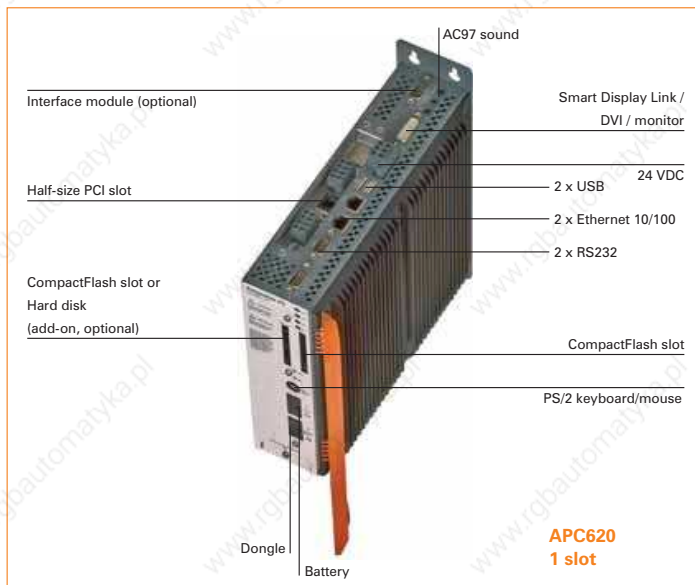

The innovative industrial PC

The new APC620 relies on experience collected over many years of industrial PC development and many applications. The result: the APC620 – providing optimal adaptability and ergonomics. The mechanical design is based on the results of extensive shock and vibration tests that place the highest demands on the materials. The APC620's main advantages are its modular design, the flexibility of the slots and the well thought out arrangement of interfaces and drives.

The display units have also been updated with new technology. Modular interfaces allow adjustments to be made to meet various requirements.

Reliability over many years

The B&R development engineers considered the importance of long-term availability when choosing which components to use. After all, the product lifespan of a B&R industrial PC series is ten years or more. Furthermore, the use of B&R industrial PCs in tough production environments places special demands on reliability and longevity. The elimination of internal cable connections for PC components, firm fitting circuit boards and the optional use of mass memory without rotating parts (CompactFlash) together with a very robust mechanical construction affords a high level of protection against breakdowns.

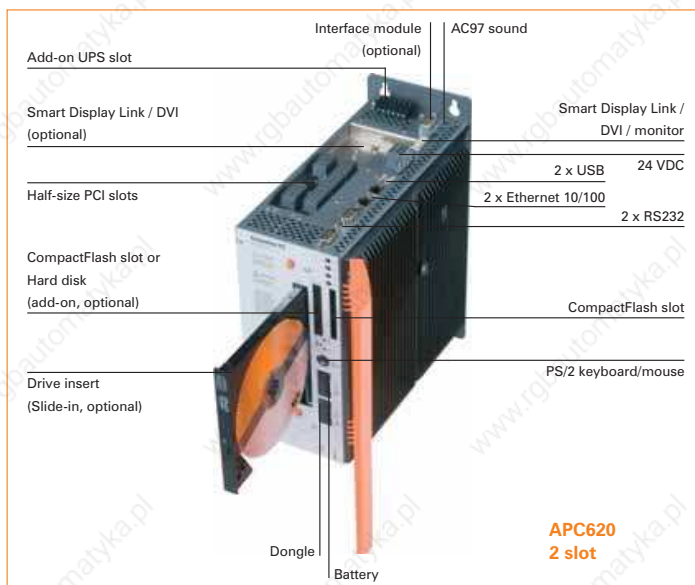

Compact construction

The APC620 saves space in the switching cabinet. Drive inserts (HDD, CD-ROM, DVD, etc.) and up to two CompactFlash slots are hidden behind a cover on the front of the device. All connections and interfaces are located on the top side of the housing. The installation depth is not increased by protruding connectors.

Fan-free

The APC620 is fan-free. All components that require cooling are placed on the board so that the heat is distributed directly to the large outer heat sink. The advantages of a fan-free system are obvious: When using CompactFlash cards, there are no rotating parts. This also eliminates maintenance work such as regularly exchanging fan filters. Maintenance costs and worn out parts are greatly reduced.

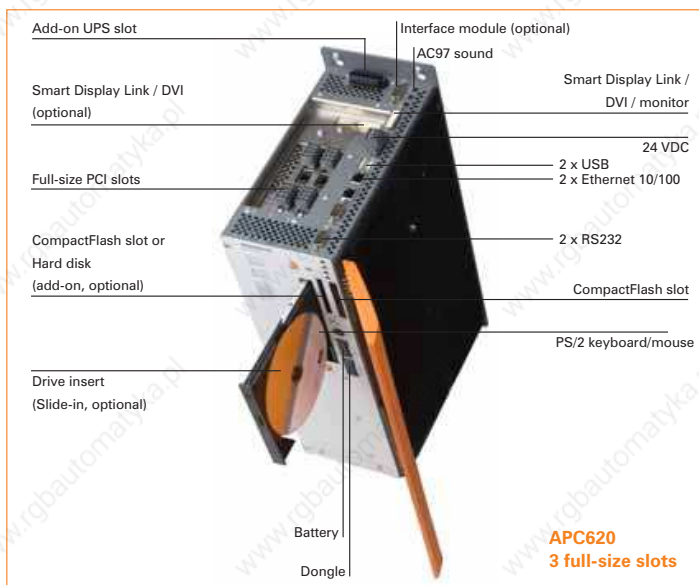

Options

Housing is available with one, two, or five half-size PCI slots. The other components have an extremely modular design. A Compact Flash slot is provided on the base system and can be supplemented with a second Compact Flash or a hard disk. There are up to two slots provided for other drives as well. CD-ROM, DVD-RW/CD-RW, floppy disk, hard disk or CompactFlash can be used. The modular plug-in technology makes it easy for the user to switch drives.

Full-size PCI slots

The APC620 with 3 long PCI slots is a new addition to B&R's Automation PC product line. Based on innovative Pentium M technology, this variant also offers several different processor and drive options.

APC620 embedded

The APC620 embedded integrates the powerful Pentium® M technology with up to 1400 MHz with the fieldbus interfaces Ethernet POWERLINK, CAN, and X2X in an extremely compact housing. The APC620 embedded is perfectly suited for complex automation tasks. All the advantages of an open system are still available when fully integrated in an automation system.



Highest performance

For applications with the highest processor performance requirements, the APC620 is available with Intel® Pentium® M and Celeron® M processors. These processors, developed specially for mobile computing, offer many advantages for industrial applications as well. They combine high computing capacity with low power consumption. The clock rates range from 600 MHz to 1.8 GHz. The Intel® 855GME chipset contains two integrated graphic engines that provide optimal use of memory for the system and graphics.

SRAM module for Automation PC 620 and Panel PC 700

The 512 KB SRAM modules expand the range of the APC620 and Panel PC 700. This allows applications that do not require a fieldbus card with integrated SRAM to store nonvolatile data in the optional SRAM module. Due to the power supply buffering integrated in the APC620 and Panel PC, Automation Runtime applications support the backup of data in the SRAM module when a power failure occurs. This module uses the buffer battery from the PC system. It is inserted directly on the PC board and doesn't require a PCI slot.

APC620 with uninterruptible power supply

With the optionally integrated UPS, the APC620 makes sure that the PC system completes all write operations even if a power failure occurs. This means that all running programs will be ended properly by the UPS software. This prevents inconsistent data. The UPS charging circuit takes up very little space in the APC620. The rechargeable batteries are mounted next to the PC and are easy to replace.

System characteristics

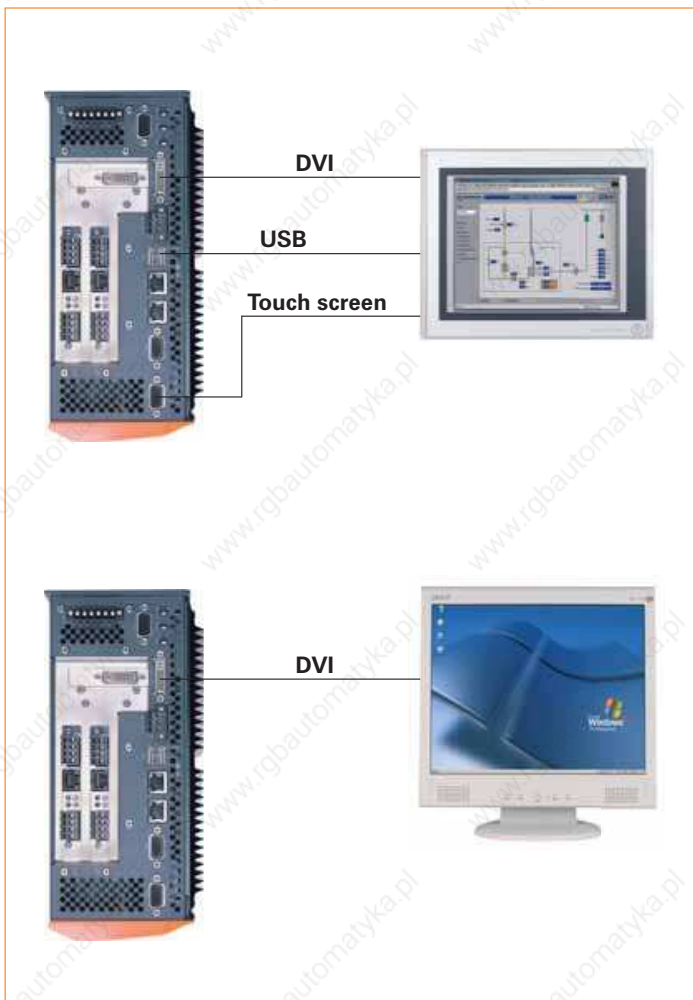

Display connection

The APC620 from B&R has an integrated interface for connecting an Automation Panel or a monitor. This industrial version also allows additional Automation Panels to be connected by inserting an optional link module. This modularity is also available on the panel. B&R offers the following possibilities in order to meet the various requirements for Panel operation:

DVI (Digital Visual Interface)

SDL (Smart Display Link)

DVI - The open standard

The DVI (Digital Visual Interface) link is based on the DVI standard defined by the Digital Display Working Group, which is also being used more frequently in today's offices. The integrated panel interface is designed so that display units and office monitors with a DVI interface can also be connected. Connections to a touch screen or remote USB interfaces require separate cables.

It is also possible to connect monitors with analog RGB interfaces.



Smart Display Link

SDL (Smart Display Link) is already integrated on the APC620. It combines the digital display interface and touch transfer for the display unit into one interface. Matrix keys, service data (temperature, operating hours) and USB signals are also transferred. SDL also allows the display unit to be equipped with PC resources such as USB drives and keyboard. Four Automation Panels can be connected via SDL to the integrated or optional SDL interfaces. The Automation Panel 900 can be combined with the Automation Panel 800, and the AP800 is always last on the line. The two lines display different content (dual independent display). Alternatively, the same display content can also be shown on all displays (display clone). Touch and key entries on the Automation Panel can be locked with software to prevent operating errors. USB is supported up to a maximum segment length of 30 m on the first two displays. Starting at a segment length of 30 m and higher, USB is only available up to a maximum of 40 m for the first respective display. USB devices can only be connected directly to the Automation Panel (without a hub).

Typical topologies

APC620 embedded for central control and visualization

The control program runs on the APC620 embedded. The visualization project is integrated with Visual Components. A display unit is connected to the PC. The PC is networked over Ethernet TCP/IP; additional Power Panel-based operator terminals can also be connected via Ethernet. Communication to I/O systems with axes is handled via fieldbus systems (CAN, Ethernet POWERLINK).

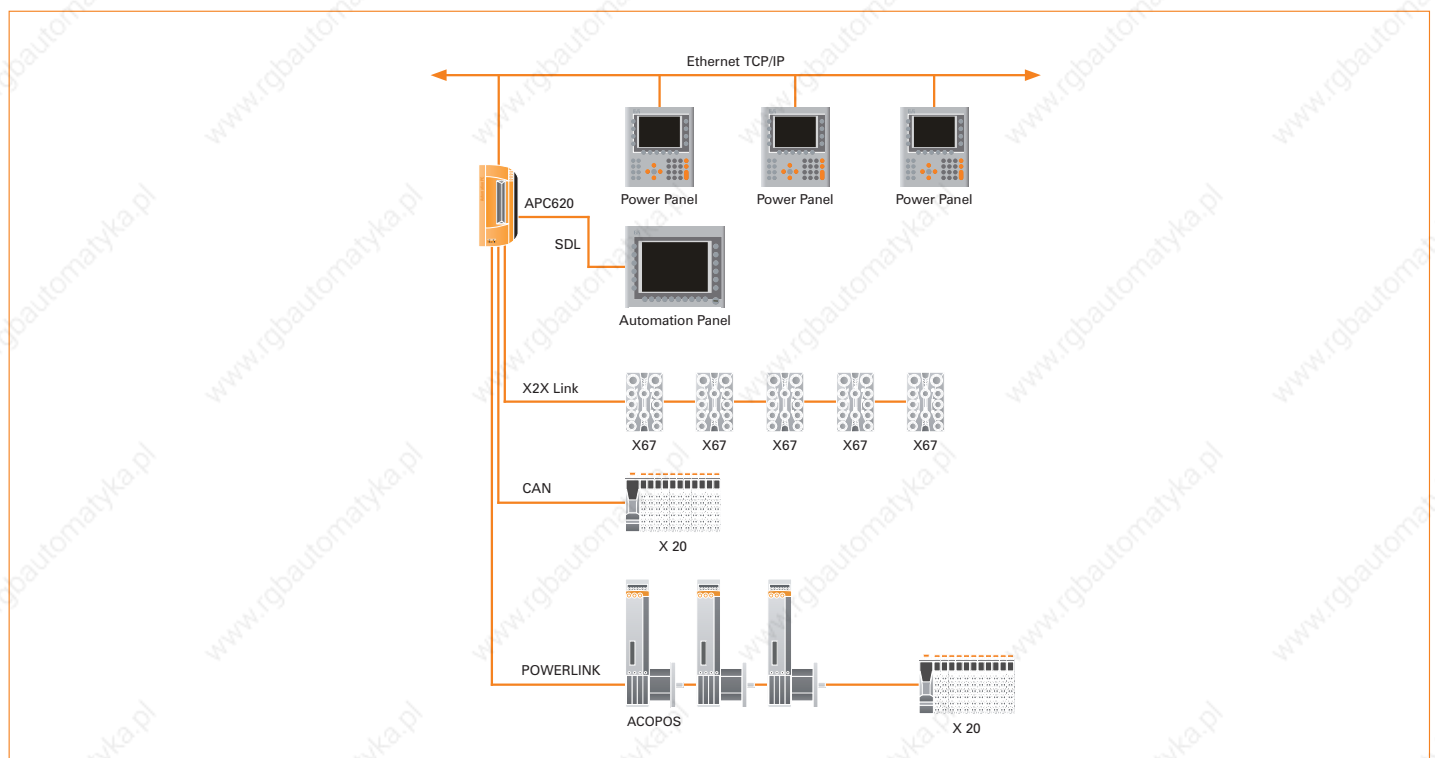

Control system	APC620: Automation PC	911
Visualization and operation	Power Panel: Integrated control, operation, and visualization	787
	Automation Panel 800: Modular operation and visualization	1055
	Automation Panel 900: Compact operation and visualization	1077
Motion control	ACOPOS: Intelligent servo drives	1251
Remote I/O systems	X67 System: Remote I/O with IP67 protection	419
	X20 System: Slice-based I/O and control system	37

APC620 as visualization device

The visualization runs as a SCADA application on the APC620. Two display units are connected to the PC either locally or remotely. The control tasks interact with one or more underlying PLC stations where I/O systems and drives are connected locally or remotely over fieldbus systems. Additional SCADA stations can be networked via Ethernet TCP/IP.

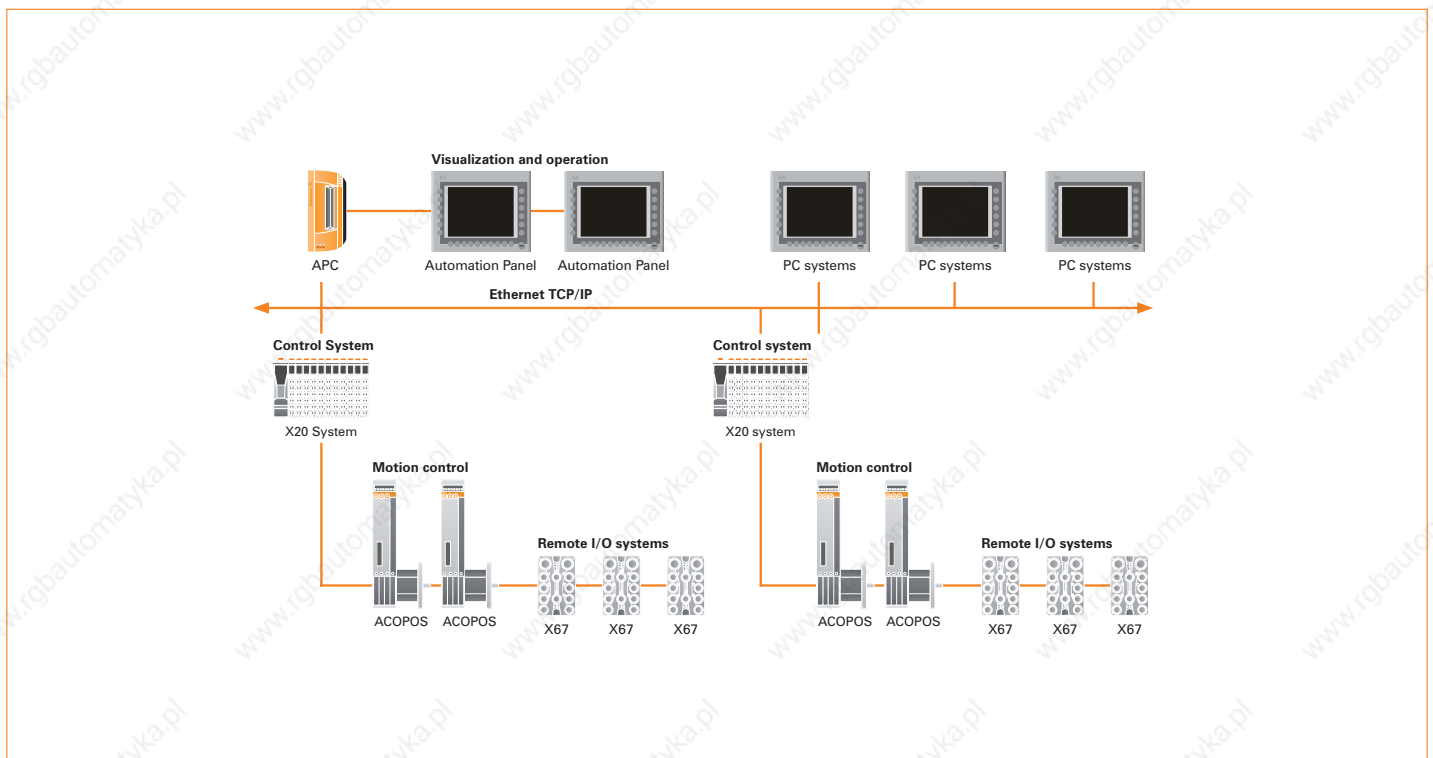

Control system	X20 System: Slice-based I/O and control system	37
	APC620: Automation PC	911
Visualization and operation	Power Panel: Integrated control, operation, and visualization	787
	Automation Panel 800: Modular operation and visualization	1055
	Automation Panel 900: Compact operation and visualization	1077
Motion control	ACOPOS: Intelligent servo drives	1251
Remote I/O systems	X67 System: Remote I/O with IP67 protection	419
	X20 System: Slice-based I/O and control system	37

Configuration

System unit (housing with main board)

Select a system unit

5PC600.SE00-00	APC620 embedded system unit, 512 kb SRAM, 1 Automation Panel Link slot (SDL)	926
5PC600.SE00-01	APC620 embedded system unit, 512 kb SRAM, 1 Automation Panel Link slot (CRT)	926
5PC600.SE00-02	APC620 embedded system unit, 1024 kb SRAM, 1 Automation Panel Link slot (SDL)	926
5PC600.SX01-00	APC620 system unit, 1 PCI slot	927
5PC600.SX02-00	APC620 system unit, 2 PCI slots, 1 drive slot, 1 Automation Panel Link slot	927
5PC600.SX02-01	APC620 system unit, 2 PCI slots, 1 drive slot	927
5PC600.SF03-00	APC620 system unit, 3 full-size PCI slots, 1 drive slot, 1 Automation Panel Link slot	928
5PC600.SX05-00	APC620 system unit, 5 PCI slots, 2 drive slots, 1 Automation Panel Link slot	928
5PC600.SX05-01	APC620 system unit, 5 PCI slots, 2 drive slots	928

CPU boards with 855 GME chipset

Select a CPU board (APC620 embedded: only 600 MHz, 1000 MHz, 1100 MHz and 1400 MHz)

5PC600.X855-00	CPU board, Intel® Pentium® M, 1100 MHz	930
5PC600.X855-01	CPU board, Intel® Pentium® M, 1600 MHz	930
5PC600.X855-02	CPU board, Intel® Pentium® M, 1400 MHz	930
5PC600.X855-03	CPU board, Intel® Pentium® M, 1800 MHz	931
5PC600.X855-04	CPU board, Intel® Celeron® M, 600 MHz	931
5PC600.X855-05	CPU board, Intel® Celeron® M, 1000 MHz	931

Memory for CPU boards with 855 GME chipset

Select a memory module

5MMDDR.0256-00	SO-DIMM DDR SDRAM, 256 MB	931
5MMDDR.0512-00	SO-DIMM DDR SDRAM, 512 MB	931
5MMDDR.1024-00	SO-DIMM DDR SDRAM, 1024 MB	931

Heat sinks for CPU boards with 855GME chipset

Select a heat sink

5AC600.HS01-01	Heat sink for half-size PCI system units with Celeron® M 600 MHz, 1000 and Pentium® M 1100 MHz, 1400 MHz.	931
5AC600.HS01-02	Heat sink for half-size PCI system units with Pentium® M 1600 MHz, 1800 MHz.	931
5AC600.HS02-01	Heat sink for full-size PCI system units with Celeron® M 600 MHz, 1000 and Pentium® M 1100 MHz, 1400 MHz.	931
5AC600.HS02-02	Heat sink for full-size PCI system units with Pentium® M 1600 MHz, 1800 MHz.	931
5AC600.HS03-01	Heat sink for APC620 embedded system units with Celeron® M 600 MHz, Celeron® M 1000 MHz, Pentium® M 1100 MHz and Pentium® M 1400 MHz.	931

Automation Panel link transmitter

Select an Automation Panel Link transmitter (for 5PC600.SX02-00, 5PC600.SX05-00 and 5PC600.SF03-00 only)

5AC600.SDL0-00	Automation Panel SDL link transmitter	924
----------------	---------------------------------------	-----

Components

Select an add-on drive (not for APC620 embedded)

5AC600.HDDI-05	40 GB add-on hard disk, 24/7 operation and expanded temperature range	923
5AC600.HDDI-06	80 GB add-on hard disk, 24/7 operation and expanded temperature range	923
5AC600.CFSI-00	Add-on CompactFlash slot	923

Select a slide-in drive (not for APC620 embedded)

5PC600.SF03-00, 5PC600.SX02-00, 5PC600.SX02-01: One drive

5PC600.SX05-00, 5PC600.SX05-01: Two drives

5AC600.HDDS-02	40 GB slide-in hard disk, 24/7 operation and expanded temperature range	923
5AC600.CFSS-00	Slide-in CompactFlash adapter for 2 CF	923
5AC600.DVDS-00	Slide-in DVD-ROM/CD-RW	923
5AC600.DVRS-00	Slide-in DVD-R/RW, DVD+R/RW	923
5AC600.CDXS-00	Slide-in CD-ROM	923
5AC600.FDDS-00	Slide-in USB FDD	923

Select max. one Raid system

5ACPCI.RAIC-03	PCI RAID system SATA 2x160 GB (controller and 2x hard disk)	923
----------------	---	-----

Select UPS

(Select combination of UPS, battery unit and cable)

5AC600.UPSI-00	Uninterruptible power supply for APC620	924
5AC600.UPSB-00	Select battery unit	924
5CAUPS.0005-00	0.5 mm APC620 UPS cable	924
5CAUPS.0030-00	3 m APC620 UPS cable	924

Select max. one SRAM module (not for APC620 embedded)

5AC600.SRAM-00	512 KB SRAM module for APC620 and PPC700	924
----------------	--	-----

Fan kits

Select a fan kit (if required)¹

5PC600.FA01-00	Fan kit for system unit 1 PCI	924
5PC600.FA02-00	Fan kit for system unit 2 PCI	924
5PC600.FA03-00	Fan kit for system unit 3 PCI	924
5PC600.FA05-00	Fan kit for system unit 5 PCI	924

¹ A fan kit may be necessary for certain system configurations.

Supply voltage connectors

Select a supply voltage connector

0TB103.9	Accessory terminal block 3-pin, screw clamps 3.31 mm ²	1131
0TB103.91	Accessory terminal block 3-pin, cage clamps 3.31 mm ²	1131

Product overview

APC620 system units



Model number	Short description	
5PC600.SE00-00	APC620 embedded system unit, 512 kB SRAM, connections for Ethernet POWERLINK, CAN, X2X, 2x RS232, 2x USB 2.0, Smart Display Link/ DVI/ Monitor, ETH 10/100; 24 VDC	926
5PC600.SE00-01	APC620 embedded system unit, 512 kB SRAM, connections for Ethernet POWERLINK, CAN, X2X, 2x RS232, 2x USB 2.0, monitor, ETH 10/100; 24 VDC	926
5PC600.SE00-02	APC620 embedded system unit, 1024 kB SRAM, connections for Ethernet POWERLINK, CAN, X2X, 2x RS232, 2x USB 2.0, Smart Display Link/ DVI/ Monitor, ETH 10/100; 24 VDC	926
5PC600.SX01-00	APC620 system unit 1 PCI slot, connections for 2 x RS232, 2 x USB 2.0, Smart Display Link / DVI / monitor, 2 x ETH 10/100, AC97 sound, PS/2 keyboard/mouse, 24 VDC.	927
5PC600.SX02-00	APC620 system unit, 2 PCI slots, 1 slot for Automation Panel link transmitter, 1 drive slot, Smart Display Link / DVI / monitor, connections for 2 x RS232, 2 x USB 2.0, 2 x ETH 10/100, AC97 sound, PS/2 keyboard/mouse, 24 VDC.	927
5PC600.SX02-01	APC620 system unit 2 PCI slots, 1 drive slot, connections for 2 x RS232, 2 x USB 2.0, Smart Display Link / DVI / monitor, 2 x ETH 10/100, AC97 sound, PS/2 keyboard/mouse, 24 VDC.	927
5PC600.SF03-00	APC620 system unit, 3 full-size PCI slots, 1 slot for Automation Panel Link transmitter, 1 drive slot; Smart Display Link/ DVI/ monitor, connections for 2 x RS232, 2 x USB 2.0, 2 x ETH 10/100, AC97 sound, PS/2 keyboard/mouse; 24 VDC.	928
5PC600.SX05-00	APC620 system unit, 5 PCI slots, 1 slot for Automation Panel link transmitter, 2 drive slots, Smart Display Link / DVI / monitor, connections for 2 x RS232, 2 x USB 2.0, 2 x ETH 10/100, AC97 sound, PS/2 keyboard/mouse, 24 VDC.	928
5PC600.SX05-01	APC620 system unit 5 PCI slots, 2 drive slots, connections for 2 x RS232, 2 x USB 2.0, Smart Display Link / DVI / monitor, 2 x ETH 10/100, AC97 sound, PS/2 keyboard/mouse, 24 VDC.	928

CPU boards, memory and heat sinks



Intel® Pentium® M / Celeron® M

Model number	Short description	
5PC600.X855-00	CPU board Intel® Pentium® M, 1100 MHz, 400 MHz PSB, 1 MB L2 cache, 855GME chipset, 1 socket for SO-DIMM DDR module.	930
5PC600.X855-01	CPU board Intel® Pentium® M, 1600 MHz, 400 MHz PSB, 1 MB L2 cache, 855GME chipset, 1 socket for SO-DIMM DDR module.	930
5PC600.X855-02	CPU board Intel® Pentium® M, 1400 MHz, 400 MHz PSB, 2 MB L2 cache, 855GME chipset, 1 socket for SO-DIMM DDR module.	930
5PC600.X855-03	CPU board Intel® Pentium® M, 1800 MHz, 400 MHz PSB, 2 MB L2 cache, 855GME chipset, 1 socket for SO-DIMM DDR module.	931
5PC600.X855-04	CPU board Intel® Celeron® M, 600 MHz, 400 MHz PSB, 512 kB L2 cache, 855GME chipset, 1 socket for SO-DIMM DDR module.	931
5PC600.X855-05	CPU board Intel® Celeron® M, 1000 MHz, 400 MHz PSB, 512 kB L2 cache, 855GME chipset, 1 socket for SO-DIMM DDR module.	931
5MMDDR.0256-00	SO-DIMM DDR SDRAM, 256 MB PC2700	931
5MMDDR.0512-00	SO-DIMM DDR SDRAM, 512 MB PC2700	931

Model number	Short description	
5MMDDR.1024-00	SO-DIMM DDR SDRAM, 1024 MB PC2700	931
5AC600.HS01-01	APC620 heat sink for CPU boards with Celeron® M 600 MHz, Celeron® M 1000 MHz, Pentium® M 1100 MHz, Pentium® M 1400 MHz	931
5AC600.HS01-02	APC620 heat sink for CPU boards with Pentium® M 1600 MHz, Pentium® M 1800 MHz	931
5AC600.HS02-01	APC620 heat sink for CPU boards with Celeron® M 600 MHz, Celeron® M 1000 MHz, Pentium® M 1100 MHz, Pentium® M 1400 MHz, for system unit 5PC600.SF03-00	931
5AC600.HS02-02	APC620 heat sink for CPU boards with Pentium® M 1600 MHz, Pentium® M 1800 MHz, for system unit 5PC600.SF03-00	931
5AC600.HS03-01	APC620 embedded heat sink for CPU boards with Celeron® M 600 MHz, Celeron® M 1000 MHz, Pentium® M 1100 MHz, Pentium® M 1400 MHz.	931

Drives



Model number	Short description
5AC600.HDDI-05	40 GB hard disk (add-on), 24/7 operation, with expanded temperature range
5AC600.HDDI-06	80 GB hard disk (add-on), 24/7 operation, with expanded temperature range
5AC600.CFSI-00	CompactFlash slot (add-on)
5AC600.CFSS-00	Dual CompactFlash slot (slide-in) (1 x IDE, 1 x USB 2.0)
5AC600.HDDS-02	40 GB hard disk (slide-in), 24/7 operation, with expanded temperature range
5AC600.DVRS-00	DVD-R/RW DVD+R/RW drive (slide-in)
5AC600.DVDS-00	DVD-ROM/CD-RW drive (slide-in)
5AC600.CDXS-00	CD-ROM drive (slide-in)
5AC600.FDDS-00	FDD drive (slide-in)
5ACPCI.RAIC-03	PCI RAID system SATA 2x160 GB (controller and 2x hard disk)
5ACPCI.RAIC-04	Replacement SATA-HDD 160 GB

Fan kits



Model number	Short description
5PC600.FA01-00	APC620 fan kit for system units with 1 PCI slot
5PC600.FA02-00	APC620 fan kit for system units with 2 PCI slots
5PC600.FA03-00	APC620 fan kit for system units with 3 PCI slots
5PC600.FA05-00	APC620 fan kit for system units with 5 PCI slots

Product overview

Automation Panel link transmitter



Model number	Short description
5AC600.SDL0-00	APC620 Smart Display Link transmitter For connecting Automation Panels to an APC620 via SDL (not for APC620 embedded).

Accessories

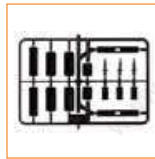

Model number	Short description
5AC900.1000-00	Adapter DVI (plug) to CRT (socket), for connecting a standard monitor to a DVI-I interface.
5AC600.ICOV-00	Interface covers for APC620 or Panel PC; 5 pcs.
5AC600.CANI-00	CAN interface, for installation in an APC620 or Panel PC. (not for APC620 embedded)
5AC600.485I-00	RS232/422/485 interface, for installation in an APC620 or Panel PC.
5AC600.UPSI-00	Uninterruptible Power Supply for APC620
5AC600.UPSB-00	Battery unit
5CAUPS.0005-00	0.5 m APC620 UPS cable
5CAUPS.0030-00	3 m APC620 UPS cable
5AC600.SRAM-00	512 KB SRAM module for APC620 and PPC700 (not for APC620 embedded)
5AC600.FA01-00	APC620 replacement fan filter, for 1 PCI system units. 5 pieces.
5AC600.FA02-00	APC620 replacement fan filter, for 2 PCI system units. 5 pieces.
5AC600.FA03-00	APC620 replacement fan filter, for 3 PCI system units. 5 pieces.
5AC600.FA05-00	APC620 replacement fan filter, for 5 PCI system units. 5 pieces.



System units



	5PC600.SE00-00	5PC600.SE00-01	5PC600.SE00-02
COM1 / COM2	RS232	RS232	RS232
Design	9-pin DSUB plug	9-pin DSUB plug	9-pin DSUB plug
Max. baud rate	115 kBit/s	115 kBit/s	115 kBit/s
USB	4 x USB 2.0 connection type A	4 x USB 2.0 connection type A	4 x USB 2.0 connection type A
Panel/Monitor interface	SDL/DVI/monitor	Monitor	SDL/ DVI/ Monitor
Design	DVI-I socket	DVI-I socket	DVI-I socket
Keyboard/Mouse	USB	USB	USB
AC97 sound	-	-	-
CompactFlash slot 1	Integrated (type I)	Integrated (type I)	Integrated (type I)
CompactFlash slot 2 ¹	Integrated (type I)	Integrated (type I)	Integrated (type I)
Hard disk ¹	-	-	-
Ethernet	1 x 10/100 MBit/s	1 x 10/100 MBit/s	1 x 10/100 MBit/s
PCI slots (half-size)	0	0	0
PCI slots (full-size)	0	0	0
SRAM	512 KB onboard	512 KB onboard	1024 KB onboard
X2X Link master	1	1	1
Ethernet POWERLINK	1	1	1
CAN	1	1	1
Automation Panel link slot	-	-	-
Battery	Lithium, 950 mAh	Lithium, 950 mAh	Lithium, 950 mAh
Real-time clock	✓	✓	✓
Dongle port	✓	✓	✓
Reset button	✓	✓	✓
Power button	✓	✓	✓
Housing fan inserts	-	-	-
Slot for optional drives	-	-	-
APC620 UPS module	Optional	Optional	Optional
Power supply	24 VDC +/- 25%	24 VDC +/- 25%	24 VDC +/- 25%
Power supply buffering	10 ms	10 ms	10 ms

¹ Either a 2nd CompactFlash slot or a hard disk can be installed at the factory (not for APC620 embedded).

Accessories

Model number	Short description	
0TB103.9	Plug, terminal block 3-pin, screw clamps 3.31 mm ²	1131
0TB103.91	Plug, terminal block 3-pin, cage clamps 3.31 mm ²	1131
	3V lithium batteries	1128
	CompactFlash cards	1126
	Accessories	1123
5SWUTI.0000-00	Nero CD-RW OEM software. Only available with a CD-RW drive.	1121



	5PC600.SX01-00	5PC600.SX02-00	5PC600.SX02-01
COM1 / COM2	RS232	RS232	RS232
Design	9-pin DSUB plug	9-pin DSUB plug	9-pin DSUB plug
Max. baud rate	115 kBit/s	115 kBit/s	115 kBit/s
USB	2 x USB 2.0 connection type A	2 x USB 2.0 connection type A	2 x USB 2.0 connection type A
Panel/Monitor interface	SDL/DVI/monitor	SDL/DVI/monitor	SDL/DVI/monitor
Design	DVI-I socket	DVI-I socket	DVI-I socket
Keyboard/Mouse	PS/2 (combined)	PS/2 (combined)	PS/2 (combined)
AC97 sound	Mic., line in, line out	Mic., line in, line out	Mic., line in, line out
CompactFlash slot 1	Integrated (type I)	Integrated (type I)	Integrated (type I)
CompactFlash slot 2 ¹	Optional (type I)	Optional (type I)	Optional (type I)
Hard disk ¹	Optional	Optional	Optional
Ethernet	2 x 10/100 Mbit/s	2 x 10/100 Mbit/s	2 x 10/100 Mbit/s
PCI slots (half-size)	1	2	2
PCI slots (full-size)	0	0	0
SRAM	512 KB optional	512 KB optional	512 KB optional
X2X Link master	-	-	-
Ethernet POWERLINK	-	-	-
CAN	Optional	Optional	Optional
Automation Panel link slot	-	✓	-
Battery	Lithium, 950 mAh	Lithium, 950 mAh	Lithium, 950 mAh
Real-time clock	✓	✓	✓
Dongle port	✓	✓	✓
Reset button	✓	✓	✓
Power button	✓	✓	✓
Housing fan inserts	✓	✓	✓
Slot for optional drives	-	1	1
APC620 UPS module	Optional	Optional	Optional
Power supply	24 VDC +/- 25%	24 VDC +/- 25%	24 VDC +/- 25%
Power supply buffering	10 ms	10 ms	10 ms

1) Either a 2nd CompactFlash slot or a hard disk can be installed at the factory.

Accessories

Model number	Short description	
0TB103.9	Plug, terminal block 3-pin, screw clamps 3.31 mm ²	1131
0TB103.91	Plug, terminal block 3-pin, cage clamps 3.31 mm ²	1131
	3V lithium batteries	1128
	CompactFlash cards	1126
	Accessories	1123
5SWUTI.0000-00	Nero CD-RW OEM software. Only available with a CD-RW drive.	1121

System units



	5PC600.SF03-00	5PC600.SX05-00	5PC600.SX05-01
COM1 / COM2	RS232	RS232	RS232
Design	9-pin DSUB plug	9-pin DSUB plug	9-pin DSUB plug
Max. baud rate	115 kBit/s	115 kBit/s	115 kBit/s
USB	2 x USB 2.0 connection type A	2 x USB 2.0 connection type A	2 x USB 2.0 connection type A
Panel/Monitor interface	SDL/DVI/monitor	SDL/DVI/monitor	SDL/DVI/monitor
Design	DVI-I socket	DVI-I socket	DVI-I socket
Keyboard/Mouse	PS/2 (combined)	PS/2 (combined)	PS/2 (combined)
AC97 sound	Mic., line in, line out	Mic., line in, line out	Mic., line in, line out
CompactFlash slot 1	Integrated (type I)	Integrated (type I)	Integrated (type I)
CompactFlash slot 2 ¹	Optional (type I)	Optional (type I)	Optional (type I)
Hard disk ¹	Optional	Optional	Optional
Ethernet	2 x 10/100 Mbit/s	2 x 10/100 Mbit/s	2 x 10/100 Mbit/s
PCI slots (half-size)	0	5	5
PCI slots (full-size)	3	0	0
SRAM	512 KB optional	512 KB optional	512 KB optional
X2X Link master	-	-	-
Ethernet POWERLINK	-	-	-
CAN	Optional	Optional	Optional
Automation Panel link slot	✓	✓	-
Battery	Lithium, 950 mAh	Lithium, 950 mAh	Lithium, 950 mAh
Real-time clock	✓	✓	✓
Dongle port	✓	✓	✓
Reset button	✓	✓	✓
Power button	✓	✓	✓
Housing fan inserts	✓	✓	✓
Slot for optional drives	1	2	2
APC620 UPS module	Optional	Optional	Optional
Power supply	24 VDC +/- 25%	24 VDC +/- 25%	24 VDC +/- 25%
Power supply buffering	10 ms	10 ms	10 ms

¹ Either a 2nd CompactFlash slot or a hard disk can be installed at the factory.

Accessories

Model number	Short description	
0TB103.9	Plug, terminal block 3-pin, screw clamps 3.31 mm ²	1131
0TB103.91	Plug, terminal block 3-pin, cage clamps 3.31 mm ²	1131
	3V lithium batteries	1128
	CompactFlash cards	1126
	Accessories	1123
5SWUTI.0000-00	Nero CD-RW OEM software. Only available with a CD-RW drive.	1121



CPU boards

CPU boards Intel® Pentium® M / Celeron® M Intel® 855 GME chipset



Model number	5PC600.X855-00	5PC600.X855-01	5PC600.X855-02
Processor	Intel® Pentium® M 1100 MHz	Intel® Pentium® M 1600 MHz	Intel® Pentium® M 1400 MHz
L2 cache	1 MB	1 MB	2 MB
External bus	400 MHz	400 MHz	400 MHz
Memory socket	1 x SO-DIMM DDR 333 MHz	1 x SO-DIMM DDR 333 MHz	1 x SO-DIMM DDR 333 MHz
BIOS	AMI	AMI	AMI
Chipset	Intel® 855GME	Intel® 855GME	Intel® 855GME
Graphics	Chipset graphics	Chipset graphics	Chipset graphics
Memory	Max. 64 MB video RAM ¹⁾	Max. 64 MB video RAM ¹⁾	Max. 64 MB video RAM ¹⁾
Resolution	Max. UXGA	Max. UXGA	Max. UXGA

¹⁾ Allocated in main memory

CPU boards Intel® Pentium® M / Celeron® M Intel® 855 GME chipset



Model number	5PC600.X855-03	5PC600.X855-04	5PC600.X855-05
Processor	Intel® Pentium® M 1800 MHz	Intel® Celeron® M 600 MHz	Intel® Celeron® M 1000 MHz
L2 cache	2 MB	512 kB	512 kB
External bus	400 MHz	400 MHz	400 MHz
Memory socket	1 x SO-DIMM DDR 333 MHz	1 x SO-DIMM DDR 333 MHz	1 x SO-DIMM DDR 333 MHz
BIOS	AMI	AMI	AMI
Chipset	Intel® 855GME	Intel® 855GME	Intel® 855GME
Graphics	Chipset graphics	Chipset graphics	Chipset graphics
Memory	Max. 64 MB video RAM ¹⁾	Max. 64 MB video RAM ¹⁾	Max. 64 MB video RAM ¹⁾
Resolution	Max. UXGA	Max. UXGA	Max. UXGA

1) Allocated in main memory.

Accessories



Model number	Short description
5AC600.HS01-01	APC620 heat sink for CPU boards with Celeron® M 600 MHz, Celeron® M 1000, Pentium® M 1100 MHz, Pentium® M 1400 MHz
5AC600.HS01-02	APC620 heat sink for CPU boards with Pentium® M 1600 MHz, Pentium® M 1800 MHz
5AC600.HS02-01	APC620 heat sink for CPU boards with Celeron® M 600 MHz, Celeron® M 1000 MHz, Pentium® M 1100 MHz, Pentium® M 1400 MHz, for system unit 5PC600.SF03-00
5AC600.HS02-02	APC620 heat sink for CPU boards with Pentium® M 1600 MHz, Pentium® M 1800 MHz, for system unit 5PC600.SF03-00
5AC600.HS03-01	APC620 embedded heat sink for CPU boards with Celeron® M 600 MHz, Celeron® M 1000 MHz, Pentium® M 1100 MHz, Pentium® M 1400 MHz.
5MMDR.0256-00	SO-DIMM DDR SDRAM, 256 MB PC2700
5MMDR.0512-00	SO-DIMM DDR SDRAM, 512 MB PC2700
5MMDR.1024-00	SO-DIMM DDR SDRAM, 1024 MB PC2700

1) Allocated in main memory.

Display links

Monitor via DVI/ CRT adapter

A monitor (via adapter) or a DVI monitor with max. SXGA resolution is connected to the integrated DVI interface.



Possible combinations

	5PC600.X855-00	5PC600.X855-01	5PC600.X855-02	5PC600.X855-03	5PC600.X855-04	5PC600.X855-05
5PC600.SE00-02	✓	-	✓	-	✓	✓
5PC600.SE00-01	✓	-	✓	-	✓	✓
5PC600.SE00-00	✓	-	✓	-	✓	✓
5PC600.SX01-00	✓	✓	✓	✓	✓	✓
5PC600.SX02-00	✓	✓	✓	✓	✓	✓
5PC600.SX02-01	✓	✓	✓	✓	✓	✓
5PC600.SF03-00	✓	✓	✓	✓	✓	✓
5PC600.SX05-00	✓	✓	✓	✓	✓	✓
5PC600.SX05-01	✓	✓	✓	✓	✓	✓

Component overview

System units

	Slot for link modules	PCI slots
5PC600.SE00-00	-	0
5PC600.SE00-02	-	0
5PC600.SX01-00	-	1
5PC600.SX02-01	-	2
5PC600.SX02-00	✓	2
5PC600.SF03-00	✓	3
5PC600.SX05-01	-	5
5PC600.SX05-00	✓	5

CPU boards

	Chipset	Processor	Resolution
5PC600.X855-00	Intel® 855GME	Pentium® M 1100 MHz	Max. UXGA
5PC600.X855-01	Intel® 855GME	Pentium® M 1600 MHz	Max. UXGA
5PC600.X855-02	Intel® 855GME	Pentium® M 1400 MHz	Max. UXGA
5PC600.X855-03	Intel® 855GME	Pentium® M 1800 MHz	Max. UXGA
5PC600.X855-04	Intel® 855GME	Celeron® M 600 MHz	Max. UXGA
5PC600.X855-05	Intel® 855GME	Celeron® M 1000 MHz	Max. UXGA

Accessories

	Type
5AC900.1000-00	DVI - CRT adapter

Automation Panel via DVI

An Automation Panel with max. SXGA resolution is connected to the integrated DVI interface. As an alternative, an office TFT with a DVI interface can also be operated. A separate cable is used for the touch screen and USB.



Possible combinations

	5PC600.X855-00	5PC600.X855-01	5PC600.X855-02	5PC600.X855-03	5PC600.X855-04	5PC600.X855-05
5PC600.SE00-02	✓	-	✓	-	✓	✓
5PC600.SE00-01	-	-	-	-	-	-
5PC600.SE00-00	✓	-	✓	-	✓	✓
5PC600.SX01-00	✓	✓	✓	✓	✓	✓
5PC600.SX02-00	✓	✓	✓	✓	✓	✓
5PC600.SX02-01	✓	✓	✓	✓	✓	✓
5PC600.SF03-00	✓	✓	✓	✓	✓	✓
5PC600.SX05-00	✓	✓	✓	✓	✓	✓
5PC600.SX05-01	✓	✓	✓	✓	✓	✓

Component overview

System units

	Slot for link modules	PCI slots
5PC600.SE00-00	-	0
5PC600.SE00-02	-	0
5PC600.SX01-00	-	1
5PC600.SX02-01	-	2
5PC600.SX02-00	✓	2
5PC600.SF03-00	✓	3
5PC600.SX05-01	-	5
5PC600.SX05-00	✓	5

CPU boards

	Chipset	Processor	Resolution
5PC600.X855-00	Intel® 855GME	Pentium® M 1100 MHz	Max. UXGA
5PC600.X855-01	Intel® 855GME	Pentium® M 1600 MHz	Max. UXGA
5PC600.X855-02	Intel® 855GME	Pentium® M 1400 MHz	Max. UXGA
5PC600.X855-03	Intel® 855GME	Pentium® M 1800 MHz	Max. UXGA
5PC600.X855-04	Intel® 855GME	Celeron® M 600 MHz	Max. UXGA
5PC600.X855-05	Intel® 855GME	Celeron® M 1000 MHz	Max. UXGA

Cables

	Type	Length
5CADVI.0018-00	DVI	1.8 m
5CADVI.0050-00	DVI	5 m
5CADVI.0100-00	DVI	10 m ¹⁾
9A0014.02	Touch screen	1.8 m
9A0014.05	Touch screen	5 m
9A0014.10	Touch screen	10 m ¹⁾
5CAUSB.0018-00	USB	1.8 m
5CAUSB.0050-00	USB	5 m

Automation Panel link module

Type	
5DL DVI.1000-01	DVI receiver

Automation Panel 900

	Diagonal	Max. resolution	Touch screen	USB	Max. segment length
5AP920.1214-01	12.1"	SVGA	✓	✓	5 m / 10 m ¹⁾
5AP920.1043-01	10.4"	VGA	✓	✓	5 m / 10 m ¹⁾
5AP920.1505-01	15.0"	XGA	✓	✓	5 m / 10 m ¹⁾
5AP920.1706-01	17.0"	SXGA	✓	✓	5 m / 10 m ¹⁾
5AP920.1906-01	19.0"	SXGA	✓	✓	5 m / 10 m ¹⁾

¹⁾ USB is limited to 5 m

Display links

Up to four Automation Panels via SDL on one line

An Automation Panel is connected to the integrated SDL interface via an SDL cable. Up to three other Automation Panels of the same type are connected to this Automation Panel and operated via SDL. All four displays show the same content.



Possible combinations

	5PC600.X855-00	5PC600.X855-01	5PC600.X855-02	5PC600.X855-03	5PC600.X855-04	5PC600.X855-05
5PC600.SE00-02	✓	-	✓	-	✓	✓
5PC600.SE00-01	-	-	-	-	-	-
5PC600.SE00-00	✓	-	✓	-	✓	✓
5PC600.SX01-00	✓	✓	✓	✓	✓	✓
5PC600.SX02-00	✓	✓	✓	✓	✓	✓
5PC600.SX02-01	✓	✓	✓	✓	✓	✓
5PC600.SF03-00	✓	✓	✓	✓	✓	✓
5PC600.SX05-00	✓	✓	✓	✓	✓	✓
5PC600.SX05-01	✓	✓	✓	✓	✓	✓

Component overview

System units

	Slot for link modules	PCI slots
5PC600.SE00-00	-	0
5PC600.SE00-02	-	0
5PC600.SX01-00	-	1
5PC600.SX02-01	-	2
5PC600.SX02-00	✓	2
5PC600.SF03-00	✓	3
5PC600.SX05-01	-	5
5PC600.SX05-00	✓	5

CPU boards

	Chipset	Processor	Resolution
5PC600.X855-00	Intel® 855GME	Pentium® M 1100 MHz	Max. UXGA
5PC600.X855-01	Intel® 855GME	Pentium® M 1600 MHz	Max. UXGA
5PC600.X855-02	Intel® 855GME	Pentium® M 1400 MHz	Max. UXGA
5PC600.X855-03	Intel® 855GME	Pentium® M 1800 MHz	Max. UXGA
5PC600.X855-04	Intel® 855GME	Celeron® M 600 MHz	Max. UXGA
5PC600.X855-05	Intel® 855GME	Celeron® M 1000 MHz	Max. UXGA

SDL cables

See AP900 SDL cable section 1087

Automation Panel link module

	Type
5DLSDL.1000-00	SDL receiver
5DLSDL.1000-01	SDL transceiver

Automation Panel 900

Display	Diagonal	Resolution	Touch screen	Keys	Max. SDL segment length w/o extender	Max. SDL segment length w/ extender
5AP920.1043-01	10.4"	VGA	✓	-	30	40
5AP980.1043-01	10.4"	VGA	✓	✓	30	40
5AP981.1043-01	10.4"	VGA	✓	✓	30	40
5AP982.1043-01	10.4"	VGA	✓	✓	30	40
5AP920.1214-01	12.1"	SVGA	✓	-	30	40
5AP920.1505-01	15.0"	XGA	✓	-	25	40
5AP980.1505-01	15.0"	XGA	✓	✓	25	40
5AP981.1505-01	15.0"	XGA	✓	✓	25	40
5AP920.1706-01	17.0"	SXGA	✓	-	20	40
5AP920.1906-01	19.0"	SXGA	✓	-	20	40

Up to four Automation Panels via SDL (optional) on one line

An Automation Panel is connected to the optional SDL transmitter via an SDL cable. Three other Automation Panels of the same type are connected to this Automation Panel and operated via SDL. All displays show the same content.



Possible combinations

	5PC600.X855-00	5PC600.X855-01	5PC600.X855-02	5PC600.X855-03	5PC600.X855-04	5PC600.X855-05
5PC600.SE00-01	-	-	-	-	-	-
5PC600.SE00-00	-	-	-	-	-	-
5PC600.SX01-00	-	-	-	-	-	-
5PC600.SX02-00	√	√	√	√	√	√
5PC600.SX02-01	-	-	-	-	-	-
5PC600.SF03-00	√	√	√	√	√	√
5PC600.SX05-00	√	√	√	√	√	√
5PC600.SX05-01	-	-	-	-	-	-

Component overview

System units

	Slot for Link modules	PCI slots
5PC600.SX02-00	√	2
5PC600.SF03-00	√	3
5PC600.SX05-00	√	5

CPU boards

	Chipset	Processor	Resolution
5PC600.X855-00	Intel® 855GME	Pentium® M 1100 MHz	Max. UXGA
5PC600.X855-01	Intel® 855GME	Pentium® M 1600 MHz	Max. UXGA
5PC600.X855-02	Intel® 855GME	Pentium® M 1400 MHz	Max. UXGA
5PC600.X855-03	Intel® 855GME	Pentium® M 1800 MHz	Max. UXGA
5PC600.X855-04	Intel® 855GME	Celeron® M 600 MHz	Max. UXGA
5PC600.X855-05	Intel® 855GME	Celeron® M 1000 MHz	Max. UXGA

SDL cables

See AP900 SDL cable section 1087

Automation Panel link module

Type	
5DLSDL.1000-00	SDL receiver
5DLSDL.1000-01	SDL transceiver

Link module APC620

Type	
5AC600.SDL0-00	SDL transmitter

Automation Panel 900

Display	Diagonal	Resolution	Touch screen	Keys	Max. segment length SDL w/o extender	Max. segment length SDL w/ extender
5AP920.1043-01	10.4"	VGA	√	-	30	40
5AP980.1043-01	10.4"	VGA	√	√	30	40
5AP981.1043-01	10.4"	VGA	√	√	30	40
5AP982.1043-01	10.4"	VGA	√	√	30	40
5AP920.1214-01	12.1"	SVGA	√	-	30	40
5AP920.1505-01	15.0"	XGA	√	-	25	40
5AP980.1505-01	15.0"	XGA	√	√	25	40
5AP981.1505-01	15.0"	XGA	√	√	25	40
5AP920.1706-01	17.0"	SXGA	√	-	20	40
5AP920.1906-01	19.0"	SXGA	√	-	20	40

Display links

Up to eight Automation Panels via SDL and SDL (optional)

Up to four Automation Panels (max. UXGA) are connected to the integrated SDL interface via an SDL cable. Four additional Automation Panels (max. UXGA) are connected to the optional SDL transmitter. The Automation Panels in each line must be the same type. The two lines display different content, but displays in the same line show the same content.



Possible combinations

	5PC600.X855-00	5PC600.X855-01	5PC600.X855-02	5PC600.X855-03	5PC600.X855-04	5PC600.X855-05
5PC600.SE00-01	-	-	-	-	-	-
5PC600.SE00-00	-	-	-	-	-	-
5PC600.SX01-00	-	-	-	-	-	-
5PC600.SX02-00	√	√	√	√	√	√
5PC600.SX02-01	-	-	-	-	-	-
5PC600.SF03-00	√	√	√	√	√	√
5PC600.SX05-00	√	√	√	√	√	√
5PC600.SX05-01	-	-	-	-	-	-

Component overview

System units

	Slot for link modules	PCI slots
5PC600.SX02-00	✓	2
5PC600.SF03-00	✓	3
5PC600.SX05-00	✓	5

SDL cables

See AP900 SDL cable section  1087

CPU boards

	Chipset	Processor	Resolution
5PC600.X855-00	Intel® 855GME	Pentium® M 1100 MHz	Max. UXGA
5PC600.X855-01	Intel® 855GME	Pentium® M 1600 MHz	Max. UXGA
5PC600.X855-02	Intel® 855GME	Pentium® M 1400 MHz	Max. UXGA
5PC600.X855-03	Intel® 855GME	Pentium® M 1800 MHz	Max. UXGA
5PC600.X855-04	Intel® 855GME	Celeron® M 600 MHz	Max. UXGA
5PC600.X855-05	Intel® 855GME	Celeron® M 1000 MHz	Max. UXGA

Automation Panel link module

	Type
5DLSDL.1000-00	SDL receiver
5DLSDL.1000-01	SDL transceiver

Link module APC620

	Type
5AC600.SDL0-00	SDL transmitter

Automation Panel 900

Display	Diagonal	Resolution	Touch screen	Keys	Max. SDL segment length w/o extender	Max. SDL segment length w/ extender
5AP920.1043-01	10.4"	VGA	✓	-	30	40
5AP980.1043-01	10.4"	VGA	✓	✓	30	40
5AP981.1043-01	10.4"	VGA	✓	✓	30	40
5AP982.1043-01	10.4"	VGA	✓	✓	30	40
5AP920.1214-01	12.1"	SVGA	✓	-	30	40
5AP920.1505-01	15.0"	XGA	✓	-	25	40
5AP980.1505-01	15.0"	XGA	✓	✓	25	40
5AP981.1505-01	15.0"	XGA	✓	✓	25	40
5AP920.1706-01	17.0"	SXGA	✓	-	20	40
5AP920.1906-01	19.0"	SXGA	✓	-	20	40

Dimensions

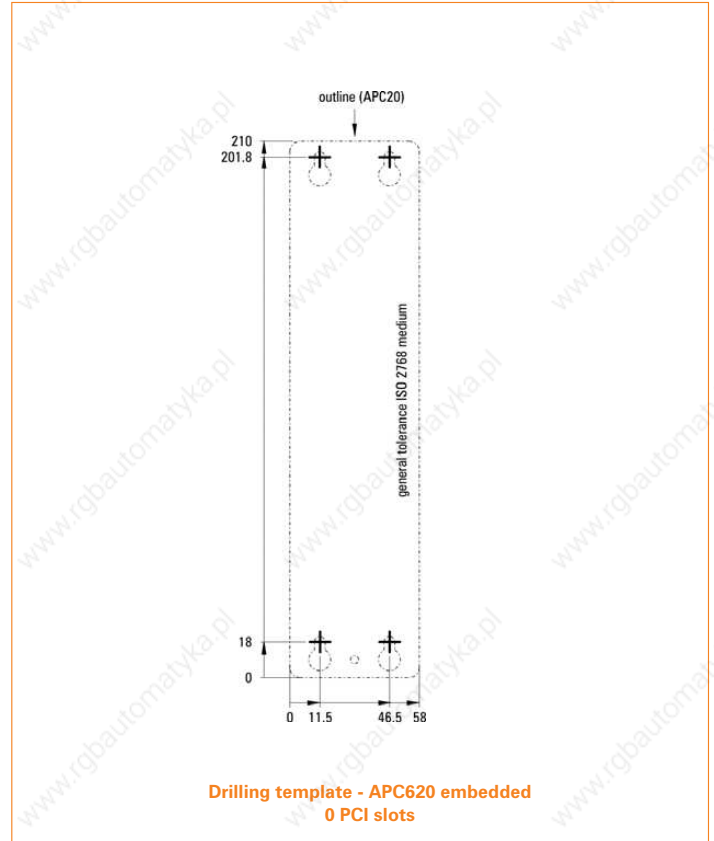
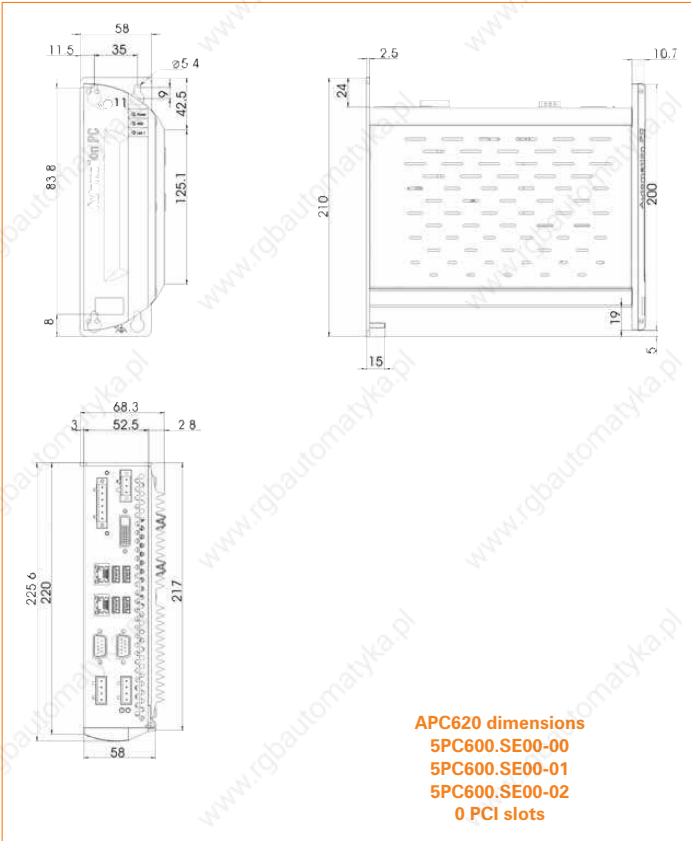

Heat sink dimensions

Heat sink	Short description	K
5AC600.HS03-01	APC620 embedded heat sink for CPU boards with Celeron® M 600 MHz, Celeron® M 1000 MHz, Pentium® M 1100 MHz, Pentium® M 1400 MHz.	12.8 mm

All dimensions in mm

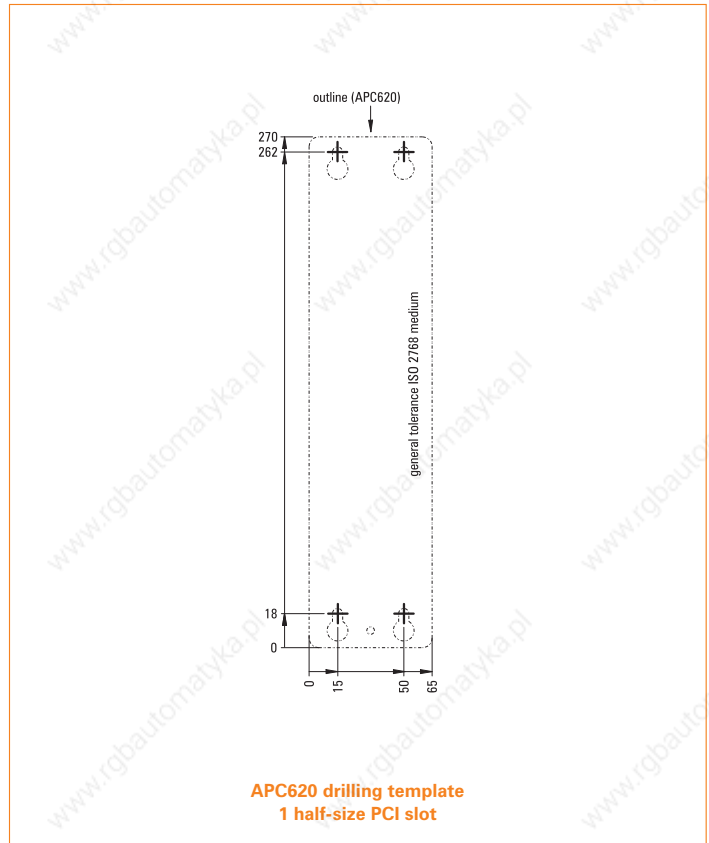
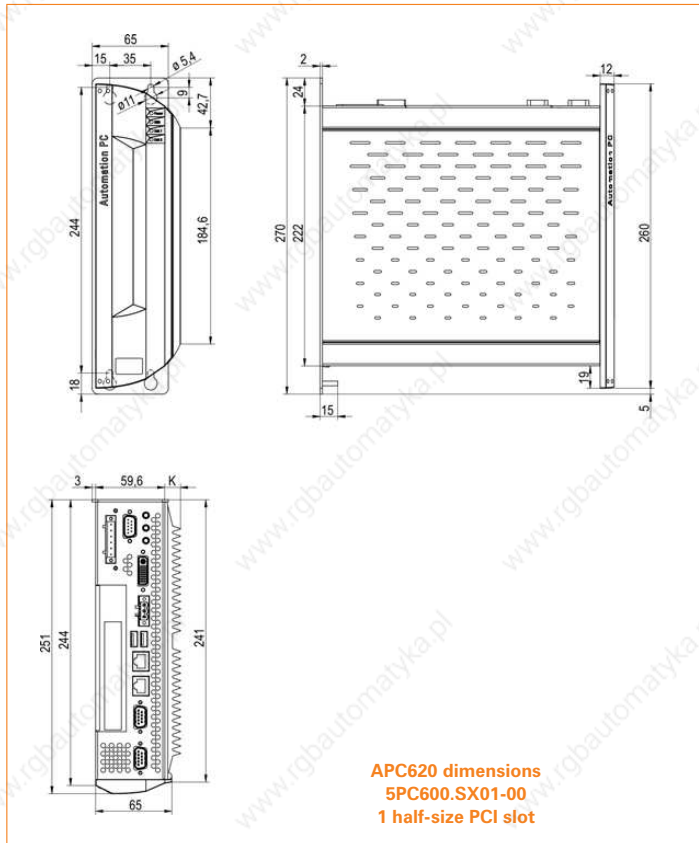

Heat sink dimensions

Heat sink	Short description	K
5AC600.HS01-01	APC620 heat sink for CPU boards with Celeron® M 600 MHz, 1000 MHz, Pentium® M 1100 MHz, 1400 MHz.	12.8 mm
5AC600.HS01-02	APC620 heat sink for CPU boards with Pentium® M 1600 MHz, 1800 MHz.	28 mm

All dimensions in mm

Dimensions

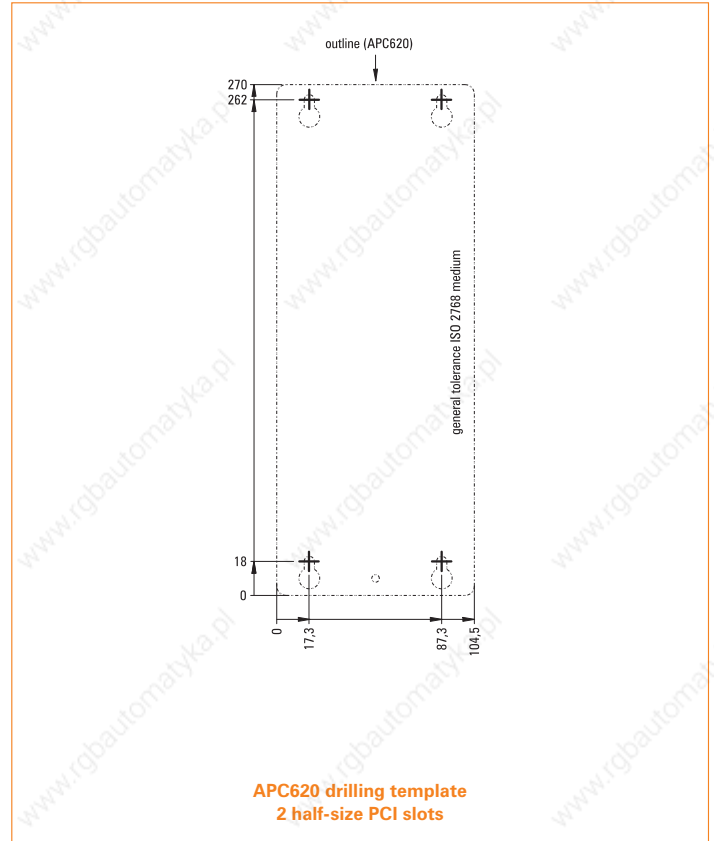
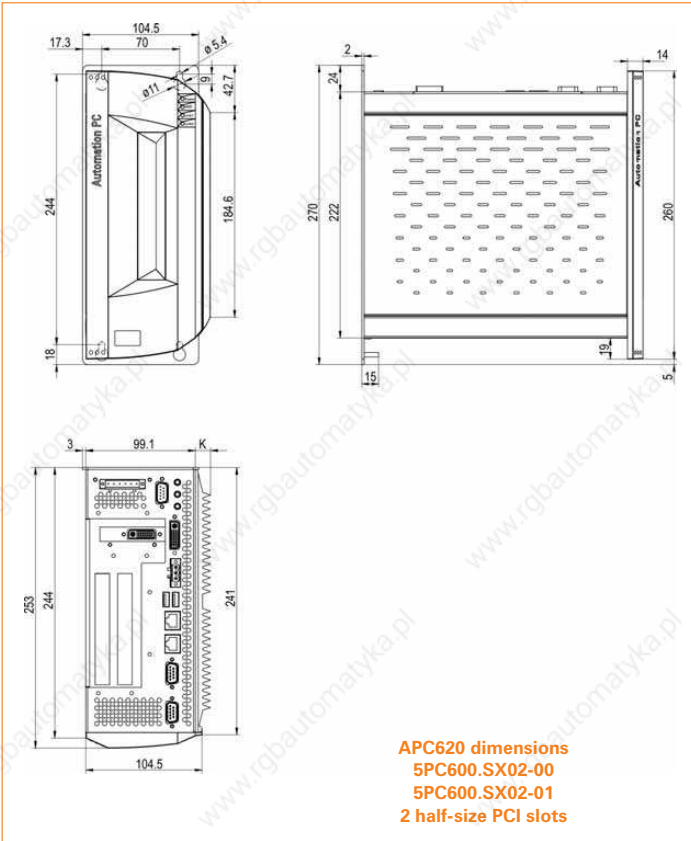

Heat sink dimensions

Heat sink	Short description	K
5AC600.HS01-01	APC620 heat sink for CPU boards with Celeron® M 600 MHz, 1000 MHz, Pentium® M 1100 MHz, 1400 MHz.	12.8 mm
5AC600.HS01-02	APC620 heat sink for CPU boards with Pentium® M 1600 MHz, 1800 MHz.	28 mm

All dimensions in mm

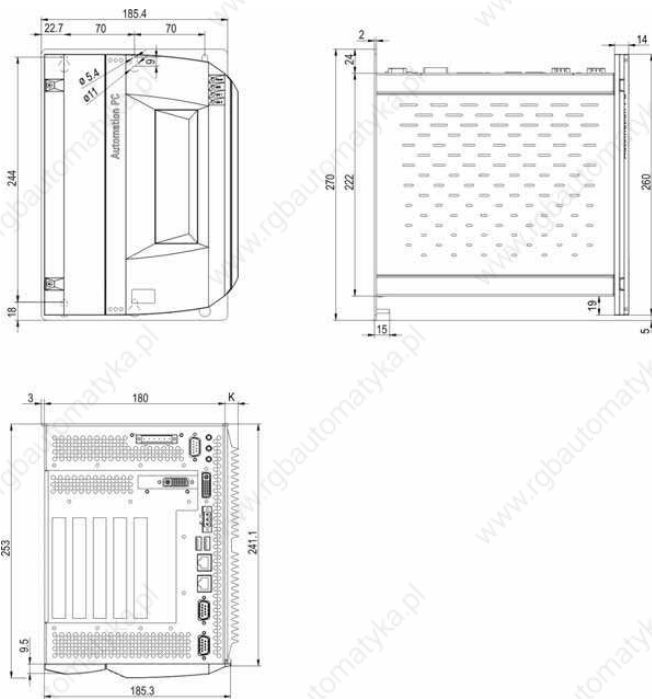

APC620 dimensions
 5PC600.SX05-00
 5PC600.SX05-01
 5 half-size PCI slots

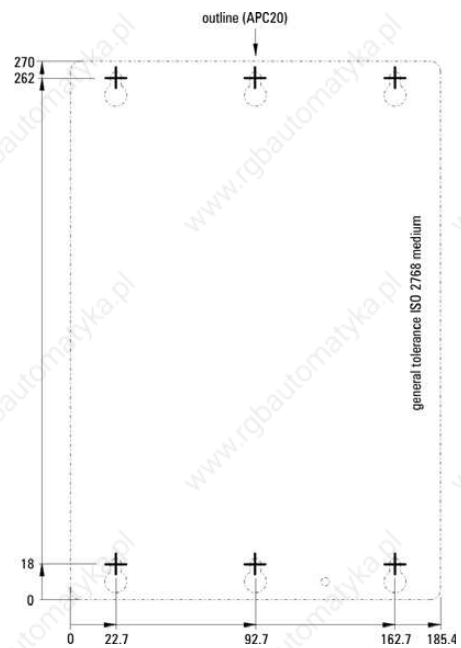

APC620 drilling template
 5 half-size PCI slots

Heat sink dimensions

Heat sink	Short description	K
5AC600.HS01-01	APC620 heat sink for CPU boards with Celeron® M 600 MHz, 1000 MHz, Pentium® M 1100 MHz, 1400 MHz.	12.8 mm
5AC600.HS01-02	APC620 heat sink for CPU boards with Pentium® M 1600 MHz, 1800 MHz.	28 mm

All dimensions in mm

Dimensions

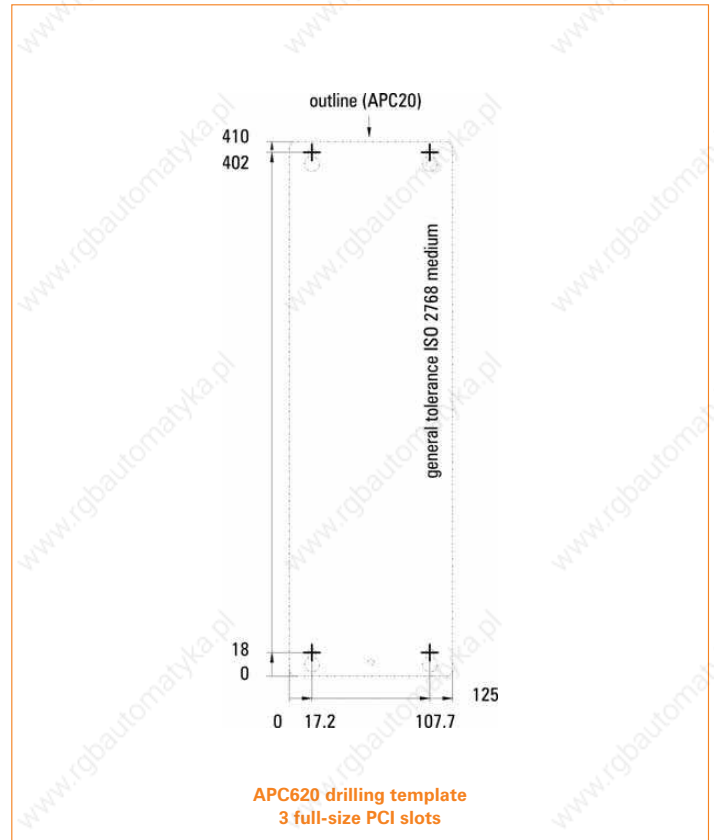
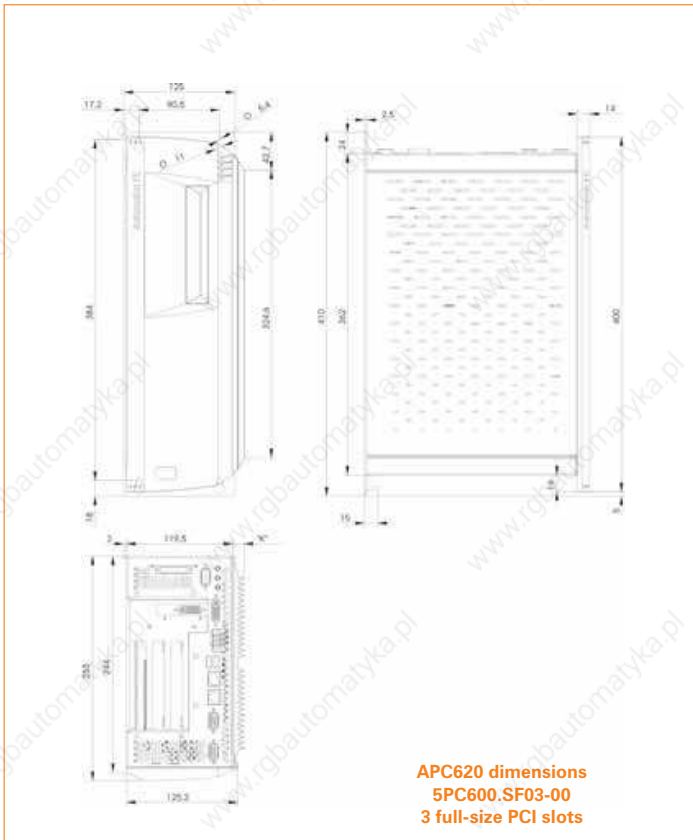

Heat sink dimensions

Heat sink	Short description	K
5AC600.HS02-01	APC620 heat sink for CPU boards with Celeron® M 600 MHz, Celeron® M 1000 MHz, Pentium® M 1100 MHz, Pentium® M 1400 MHz, for system unit 5PC600.SF03-00	12.8 mm
5AC600.HS02-02	APC620 heat sink for CPU boards with Pentium® M 1600 MHz, Pentium® M 1800 MHz, for system unit 5PC600.SF03-00	28 mm

All dimensions in mm

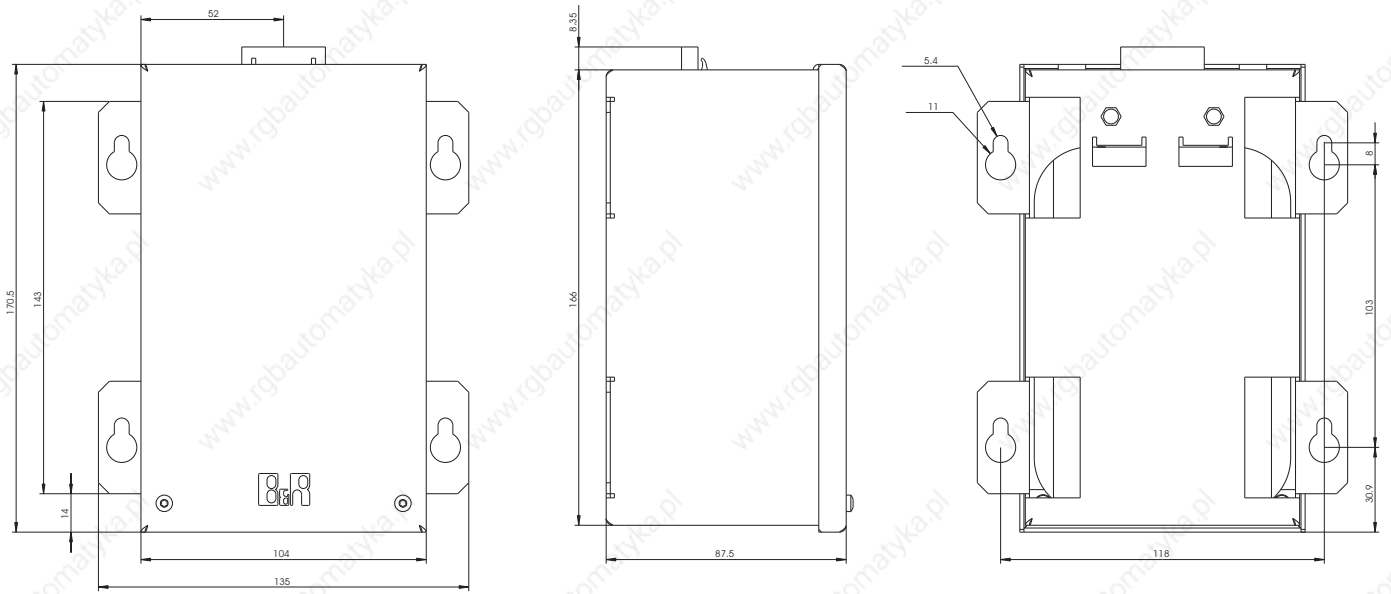

**Dimensions
UPS battery unit**

Model number	Short description
5AC600.UPSB-00	Battery unit

All dimensions in mm