

# SIEMENS

## SIMATIC

### Distributed I/O System ET 200S

#### Manual

Terminal modules

1

Power modules

2

Digital electronic modules

3

Analog electronic modules

4

4 IQ-SENSE  
(6ES7138-4GA00-0AB0)

5

RESERVE modules

6

## Safety Guidelines

This manual contains notices you have to observe in order to ensure your personal safety, as well as to prevent damage to property. The notices referring to your personal safety are highlighted in the manual by a safety alert symbol, notices referring only to property damage have no safety alert symbol. These notices shown below are graded according to the degree of danger.



---

### Danger

indicates that death or severe personal injury **will** result if proper precautions are not taken.

---



---

### Warning

indicates that death or severe personal injury **may** result if proper precautions are not taken.

---



---

### Caution

with a safety alert symbol, indicates that minor personal injury can result if proper precautions are not taken.

---

---

### Caution

without a safety alert symbol, indicates that property damage can result if proper precautions are not taken.

---

---

### Notice

indicates that an unintended result or situation can occur if the corresponding information is not taken into account.

---

If more than one degree of danger is present, the warning notice representing the highest degree of danger will be used. A notice warning of injury to persons with a safety alert symbol may also include a warning relating to property damage.

## Qualified Personnel

The device/system may only be set up and used in conjunction with this documentation. Commissioning and operation of a device/system may only be performed by **qualified personnel**. Within the context of the safety notes in this documentation qualified persons are defined as persons who are authorized to commission, ground and label devices, systems and circuits in accordance with established safety practices and standards.

## Prescribed Usage

Note the following:



---

### Warning

This device may only be used for the applications described in the catalog or the technical description and only in connection with devices or components from other manufacturers which have been approved or recommended by Siemens. Correct, reliable operation of the product requires proper transport, storage, positioning and assembly as well as careful operation and maintenance.

---

## Trademarks

All names identified by ® are registered trademarks of the Siemens AG. The remaining trademarks in this publication may be trademarks whose use by third parties for their own purposes could violate the rights of the owner.

## Disclaimer of Liability

We have reviewed the contents of this publication to ensure consistency with the hardware and software described. Since variance cannot be precluded entirely, we cannot guarantee full consistency. However, the information in this publication is reviewed regularly and any necessary corrections are included in subsequent editions.

# Table of contents

<b>1</b>	<b>Terminal modules</b> .....	<b>1-1</b>
1.1	Terminal module TM-P15S23-A1, TM-P15C23-A1 and TM-P15N23-A1 (6ES7193-4CCx0-0AA0).....	1-1
1.2	Terminal modules TM-P15S23-A0, TM-P15C23-A0 and TM-P15N23-A0 (6ES7193-4CDx0-0AA0).....	1-3
1.3	TM-P15S22-01, TM-P15C22-01 and TM-P15N22-01 terminal modules (6ES7193-4CEx0-0AA0).....	1-4
1.4	TM-P30S44-A0 and TM-P30C44-A0 terminal modules (6ES7193-4CKx0-0AA0) .....	1-5
1.5	TM-PF30S47-F1 terminal module for PM-D F DC24V PROFIsafe (3RK1903-3AA00).....	1-7
1.6	TM-E15S26-A1, TM-E15C26-A1 and TM-E15N26-A1 universal terminal modules (6ES7193-4CAx0-0AA0).....	1-8
1.7	Terminal module TM-E15S24-A1, TM-E15C24-A1 and TM-E15N24-A1 (6ES7193-4CAx0-0AA0).....	1-9
1.8	TM-E15S24-01, TM-E15C24-01 and TM-E15N24-01 terminal modules (6ES7193-4CBx0-0AA0).....	1-11
1.9	TM-E15S23-01, TM-E15C23-01 and TM-E15N23-01 terminal modules (6ES7193-4CBx0-0AA0).....	1-12
1.10	Terminal module TM-E15S24-AT and TM-E15C24-AT (6ES7193-4CLx0-0AA0).....	1-13
1.11	TM-E30S46-A1 and TM-E30C46-A1 universal terminal modules (6ES7193-4CFx0-0AA0)...	1-15
1.12	TM-E30S44-01 and TM-E30C44-01 terminal modules (6ES7193-4CGx0-0AA0) .....	1-17
1.13	TM-C120S and TM-C120C terminal modules (6ES7193-4DLx0-0AA0) .....	1-18
1.14	TE-U120S4x10 and TE-U120C4x10 supplementary terminal (6ES7193-4FLx0-0AA0) .....	1-19
<b>2</b>	<b>Power modules</b> .....	<b>2-1</b>
2.1	Configuring the address space .....	2-1
2.2	Parameters for power modules.....	2-2
2.3	PM-E 24 VDC power module (6ES7138-4CA01-0AA0) .....	2-3
2.4	PM-E 24-48 VDC power module (6ES7138-4CA50-0AA0).....	2-6
2.5	PM-E 24-48 VDC/24-230 VAC power module (6ES7138-4CB10-0AB0) .....	2-9
2.6	Placing power modules and connecting them to common potential.....	2-12
2.7	Example of a configuration: Terminal modules for power modules.....	2-14
2.8	Finding the correct power module for an I/O device .....	2-16

<b>3</b>	<b>Digital electronic modules</b> .....	<b>3-1</b>
3.1	Parameters for digital electronic modules .....	3-1
3.1.1	Parameters for digital input modules .....	3-1
3.1.2	Parameters for 4DI NAMUR.....	3-2
3.1.3	Parameters for digital output modules .....	3-3
3.2	Parameters of the Digital Electronic Modules .....	3-4
3.2.1	Hardware interrupt .....	3-4
3.2.2	Input delay .....	3-4
3.2.3	Trigger for hardware interrupt, rising edge.....	3-4
3.2.4	Pulse stretching.....	3-5
3.2.5	Chatter monitoring.....	3-6
3.3	2DI 24 VDC ST digital electronic module (6ES7131-4BB01-0AA0) .....	3-8
3.4	4DI 24 VDC Standard digital electronic module (6ES7131-4BD01-0AA0).....	3-12
3.5	4DI 24 VDC/SRC Standard digital electronic module (6ES7131-4BD51-0AA0) .....	3-15
3.6	2DI 24 VDC High Feature digital electronic module (6ES7131-4BB01-0AB0).....	3-19
3.7	4DI 24 VDC High Feature digital electronic module (6ES7131-4BD01-0AB0).....	3-23
3.8	4DI 24 VUC to 48 VUC High Feature digital electronic module (6ES7131-4CD00-0AB0).....	3-27
3.9	4DI NAMUR digital electronic module (6ES7131-4RD01-0AB0).....	3-31
3.10	2DI 120 VAC Standard digital electronic module (6ES7131-4EB01-0AB0) .....	3-42
3.11	2DI 230 VAC Standard digital electronic module (6ES7131-4FB01-0AB0) .....	3-45
3.12	2DO 24 VDC/0.5 A Standard digital electronic module (6ES7132-4BB01-0AA0).....	3-48
3.13	Standard digital electronic module 4DO 24 VDC/0.5 A (6ES7132-4BD01-0AA0).....	3-52
3.14	2DO 24 VDC/0.5 A High Feature digital electronic module (6ES7132-4BB01-0AB0).....	3-56
3.15	2DO 24 VDC/2 A Standard digital electronic module (6ES7132-4BB31-0AA0).....	3-60
3.16	4DO 24 VDC/2 A Standard digital electronic module (6ES7132-4BD31-0AA0).....	3-64
3.17	2DO 24 VDC/2 A High Feature digital electronic module (6ES7132-4BB31-0AB0).....	3-68
3.18	2DO 24 VAC to 230 VAC digital electronic module (6ES7132-4FB01-0AB0).....	3-73
3.19	2RO NO 24 VDC to 120 VDC/5 A, 24 VDC to 230 VAC/5 A digital electronic module (6ES7132-4HB01-0AB0).....	3-77
3.20	2RO NO/NC 24 VDC to 48 VDC/5 A, 24 VAC to 230 VAC/5 A digital electronic module (6ES7132-4HB11-0AB0).....	3-82
<b>4</b>	<b>Analog electronic modules</b> .....	<b>4-1</b>
4.1	Introduction .....	4-1
4.2	Analog value representation .....	4-1
4.2.1	Overview .....	4-1
4.2.2	Analog Value Representation for Measuring Ranges with SIMATIC S7 .....	4-2
4.2.3	Measuring ranges of the analog input modules in SIMATIC S7 format for voltage, current and resistance-type sensors .....	4-4
4.2.4	Measuring Range of the Analog Input Modules in SIMATIC S7 Format for Resistance Thermometers.....	4-6
4.2.5	Measuring Range of the Analog Input Modules in SIMATIC S7 Format for Thermocouples ....	4-9
4.2.6	Output ranges of the analog output modules in SIMATIC S7 format for voltage and current .	4-13

4.3	Basics of Analog Value Processing .....	4-14
4.3.1	Connecting measuring sensors .....	4-14
4.3.2	Connecting Thermocouples .....	4-18
4.3.3	Wiring unused channels of the analog input modules .....	4-23
4.4	Response of the Analog Modules during Operation and if Faults Occur .....	4-24
4.4.1	Influence of the power supply and the operating status on analog input and output values...	4-24
4.4.2	Influence of the Value Range on the Analog Input .....	4-25
4.4.3	Influence of the Value Range on the Analog Output .....	4-25
4.4.4	Using the shield connection .....	4-26
4.5	Parameters for analog electronic modules .....	4-26
4.5.1	Parameters for analog electronic modules 2AI U Standard, 2AI I 2WIRE Standard, 4AI I 2WIRE Standard, 2AI I 4WIRE Standard .....	4-26
4.5.2	Parameters for analog electronic modules 2AI U High Feature and 2AI I 2/4WIRE High Feature .....	4-27
4.5.3	Parameters for analog electronic modules 2AI U High Speed, 2AI I 2WIRE High Speed and 2AI I 4WIRE High Speed .....	4-28
4.5.4	Parameters for analog electronic modules 2AI RTD Standard, 2AI TC Standard and 2AI TC High Feature .....	4-29
4.5.5	Parameters for 2AI RTD High Feature analog electronic module .....	4-30
4.5.6	Parameters for analog electronic modules 2AO U Standard, 2AO U High Feature and 2AO I Standard, 2AO I High Feature .....	4-33
4.5.7	Parameters of the Analog Electronic Modules.....	4-34
4.6	2AI U Standard analog electronic module (6ES7134-4FB01-0AB0).....	4-37
4.7	2AI U High Feature analog electronic module (6ES7134-4FB00-0AB0).....	4-41
4.8	2AI U High Speed analog electronic module (6ES7134-4FB51-0AB0).....	4-45
4.9	2AI I 2WIRE Standard analog electronic module (6ES7134-4GB01-0AB0) .....	4-49
4.10	4AI I 2WIRE Standard analog electronic module (6ES7134-4GD00-0AB0) .....	4-53
4.11	2AI I 2WIRE High Speed analog electronic module (6ES7134-4GB51-0AB0) .....	4-57
4.12	2AI I 4WIRE Standard analog electronic module (6ES7134-4GB11-0AB0) .....	4-61
4.13	2AI I 2/4WIRE High Feature analog electronic module (6ES7134-4MB00-0AB0) .....	4-65
4.14	2AI I 4WIRE High Speed analog electronic module (6ES7134-4GB61-0AB0) .....	4-69
4.15	2AI RTD Standard analog electronic module (6ES7134-4JB50-0AB0).....	4-73
4.16	2AI RTD High Feature analog electronic module (6ES7134-4NB51-0AB0) .....	4-77
4.17	2AI TC Standard analog electronic module (6ES7134-4JB00-0AB0) .....	4-85
4.18	2AI RTD High Feature analog electronic module (6ES7134-4NB01-0AB0) .....	4-90
4.19	2AO U Standard analog electronic module (6ES7135-4FB01-0AB0) .....	4-95
4.20	2AO U High Feature analog electronic module (6ES7135-4LB02-0AB0) .....	4-99
4.21	2AO I Standard analog electronic module (6ES7135-4GB01-0AB0) .....	4-103
4.22	2AO I High Feature analog electronic module (6ES7135-4MB02-0AB0).....	4-106

<b>5</b>	<b>4 IQ-SENSE (6ES7138-4GA00-0AB0)</b> .....	<b>5-1</b>
5.1	Features of 4 IQ-SENSE.....	5-1
5.2	Parameters for the 4 IQ-SENSE .....	5-2
5.2.1	Parameters.....	5-2
5.2.2	Group diagnostics parameter.....	5-3
5.2.3	Synchronization group parameter.....	5-3
5.2.4	Sensor type parameter.....	5-5
5.2.5	Switching hysteresis parameter .....	5-6
5.2.6	Time functions, time values parameters .....	5-7
5.2.7	Teach-in disable parameter .....	5-7
5.3	Control interface (PIQ) and feedback interface (PII).....	5-8
5.3.1	Basics of control interface (PIQ) and feedback interface (PII).....	5-8
5.3.2	Standard.....	5-9
5.3.3	Enhanced .....	5-10
5.4	Technical Specifications.....	5-14
<b>6</b>	<b>RESERVE modules</b> .....	<b>6-1</b>
	<b>Glossary</b> .....	<b>Glossary-1</b>
	<b>Index</b> .....	<b>Index-1</b>

**Tables**

Table 1-1	Potential groups on the supplementary terminal .....	1-19
Table 2-1	PII feedback interface and PIQ control interface .....	2-1
Table 2-2	Parameters for power modules .....	2-2
Table 2-3	Terminal modules for power modules.....	2-14
Table 3-1	Parameters for digital input modules .....	3-1
Table 3-2	Parameters for 4DI NAMUR.....	3-2
Table 3-3	Parameters for digital output modules .....	3-3
Table 3-4	Diagnosis for changeover contacts.....	3-41
Table 3-5	Switching capacity and lifetime of the relay contacts.....	3-81
Table 3-6	Switching capacity and lifetime of the contacts.....	3-86
Table 4-1	Measured Values in the Event of Wire Break Dependent on Enabled Diagnostics .....	4-2
Table 4-2	Analog Value Representation (SIMATIC S7 Format) .....	4-2
Table 4-3	Measured Value Resolution of the Analog Values (SIMATIC S7 Format) .....	4-3
Table 4-4	SIMATIC S7 format: measuring ranges $\pm 80$ mV, $\pm 2.5$ V, $\pm 5$ V and $\pm 10$ V.....	4-4
Table 4-5	SIMATIC S7 format: measuring ranges 1 V to 5 V, 0 mA to 20 mA, 4 mA to 20 mA .....	4-5
Table 4-6	SIMATIC S7 format: Measuring range $\pm 20$ mA .....	4-5
Table 4-7	SIMATIC S7 format: Measuring ranges 150 $\Omega$ , 300 $\Omega$ , 600 $\Omega$ , 3000 $\Omega$ .....	4-6
Table 4-8	SIMATIC S7 format: Measuring ranges Pt 100, 200, 500, 1000 Standard in $^{\circ}$ C and $^{\circ}$ F .....	4-6
Table 4-9	SIMATIC S7 format: Measuring ranges Pt 100, 200, 500, 1000 Climatic in $^{\circ}$ C and $^{\circ}$ F.....	4-7
Table 4-10	SIMATIC S7 format: Measuring ranges Ni 100, 120, 200, 500, 1000 Standard in $^{\circ}$ C and $^{\circ}$ F ...	4-7
Table 4-11	SIMATIC S7 format: Measuring ranges Ni 100, 120, 200, 500, 1000 Climatic in $^{\circ}$ C and $^{\circ}$ F.....	4-8

Table 4-12	SIMATIC S7 format: Measuring ranges Cu 10 Standard in °C and °F .....	4-8
Table 4-13	SIMATIC S7 format: Measuring ranges Cu 10 Climatic in °C and °F.....	4-9
Table 4-14	SIMATIC S7 format: Measuring range Type B in °C and °F.....	4-9
Table 4-15	SIMATIC S7 format: Measuring range Type C in °C and °F .....	4-10
Table 4-16	SIMATIC S7 format: Measuring range Type E in °C and °F.....	4-10
Table 4-17	SIMATIC S7 format: Measuring range Type J in °C and °F .....	4-11
Table 4-18	SIMATIC S7 format: Measuring range Type K in °C and °F.....	4-11
Table 4-19	SIMATIC S7 format: Measuring range Type L in °C and °F .....	4-11
Table 4-20	SIMATIC S7 format: Measuring range Type N in °C and °F .....	4-12
Table 4-21	SIMATIC S7 format: Measuring range Type R, S in °C and °F .....	4-12
Table 4-22	SIMATIC S7 format: Measuring range Type T in °C and °F.....	4-13
Table 4-23	SIMATIC S7 format: output range ± 5 V; ± 10 V; ± 20 mA.....	4-13
Table 4-24	SIMATIC S7 format: Output ranges 1 V to 5 V; 4 mA to 20 mA.....	4-14
Table 4-25	Compensation of the reference junction temperature .....	4-18
Table 4-26	Reference junction parameters.....	4-21
Table 4-27	Dependence of the Input and Output Values on the Operating State of the PLC (CPU of the DP Master) and the Power Supply Voltage L+ .....	4-24
Table 4-28	Response of the Analog Modules, Depending on the Location of the Analog Input Value in the Range of Values .....	4-25
Table 4-29	Response of the Analog Modules, Depending on the Location of the Analog Output Value in the Range of Values .....	4-25
Table 4-30	Parameters for analog input modules U, I Standard .....	4-26
Table 4-31	Parameters for analog electronic modules U, I High Feature.....	4-27
Table 4-32	Parameters for analog input modules U, I High Speed .....	4-28
Table 4-33	Parameters for analog input modules RTD, TC.....	4-29
Table 4-34	Parameters for 2AI RTD High Feature analog electronic module .....	4-30
Table 4-35	Parameters for analog output modules U, I .....	4-33
Table 5-1	Parameters for the 4 IQ-SENSE .....	5-2
Table 5-2	Diffuse sensor .....	5-5
Table 5-3	Retro-reflective sensor .....	5-5
Table 5-4	Standard feedback interface .....	5-9
Table 5-5	Enhanced feedback interface .....	5-10
Table 5-6	Enhanced control interface .....	5-11





## Terminal modules

Terminal modules implement the electrical and mechanical connection of the I/O modules with the interface module and the terminating module.

- The inserted I/O module determines the signals to terminals 1 to 16, A3, A4, A7, A8, A11, A12, A15, A16.
- Depending on the selected terminal module, only specific terminals are available.

Select the required terminal module based on the potentials required by your application. For more information on the signal assignment see the *ET 200S Distributed I/O System* manual in the description of the specific I/O module.

An AUX(iliary) bus AUX1 is integrated into the terminal modules. Any desired potential (up to 230 VAC) can be applied there. You can set the AUX(iliary) bus individually:

- As a protective conductor bar
- For additionally required voltage

### 1.1 Terminal module TM-P15S23-A1, TM-P15C23-A1 and TM-P15N23-A1 (6ES7193-4CCx0-0AA0)

#### Properties

- Terminal module for power modules
- Infeed for a new potential group up to the next TM-P terminal module
- Available in two variants: screw terminal, spring terminal, "fast connect" quick connection method without stripping
- The signal assignment of the AUX1 bus is specified by the feed to the power module of this potential group.
- Pass-through AUX1 bus with electrical connection to the next potential group to the left
- Access to the AUX1 potential through terminals A4 and A8

**Block diagram**

Block diagram of the TM-P15S23-A1, TM-P15C23-A1, and TM-P15N23-A1 terminal modules

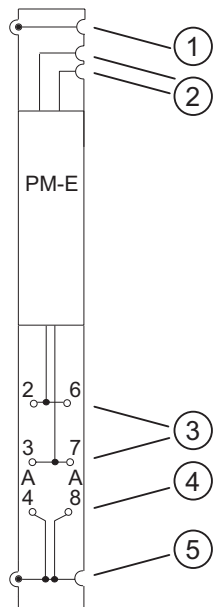

- (1) Backplane bus
- (2) Infeed of the power buses to the electronic modules
- (3) Terminals with connection to the power module
- (4) Use of terminals A4 and A8 as protective conductor terminals or potential terminals of any kind
- (5) Infeed of the AUX1 bus by means of terminals A4 and A8

**TM-P15x23-A1 Technical Specifications (6ES7193-4CCx0-0AA0)**

Dimensions and Weight	
Dimensions W × H × D (mm)	
• Screw-type/spring terminals	15 × 132 × 43
• Fast Connect	15 × 162 × 43
Weight	Approx. 65 g

## 1.2 Terminal modules TM-P15S23-A0, TM-P15C23-A0 and TM-P15N23-A0 (6ES7193-4CDx0-0AA0)

### Properties

- Terminal module for power modules
- Infeed for a new potential group up to the next TM-P terminal module
- Available in two variants: screw terminal, spring terminal, "fast connect" quick connection method without stripping
- The signal assignment of the AUX1 bus is specified by the feed to the power module of this potential group.
- Interrupted AUX1 bus without electrical connection to the next potential group to the left
- Access to the AUX1 potential through terminals A4 and A8

### Block diagram

Block diagram for the TM-P15S23-A0, TM-P15C23-A0, and TM-P15N23-A0 terminal modules

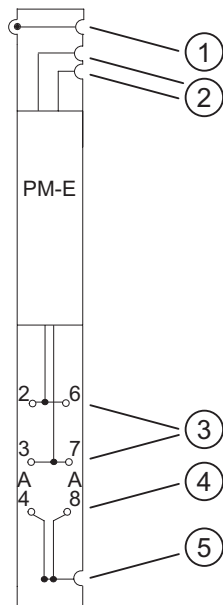

- (1) Backplane bus
- (2) Infeed of the power buses to the electronic modules
- (3) Terminals with connection to the power module
- (4) Use of terminals A4 and A8 as protective conductor terminals or potential terminals of any kind
- (5) Infeed of the AUX1 bus by means of terminals A4 and A8

**TM-P15x23-A0 Technical Specifications (6ES7193-4CDx0-0AA0)**

Dimensions and Weight	
Dimensions W × H × D (mm)	
• Screw-type/spring terminals	15 × 132 × 43
• Fast Connect	15 × 162 × 43
Weight	Approx. 65 g

**1.3 TM-P15S22-01, TM-P15C22-01 and TM-P15N22-01 terminal modules (6ES7193-4CEX0-0AA0)**

**Properties**

- Terminal module for power modules
- Infeed for a new potential group up to the next TM-P terminal module
- Available in two variants: screw terminal, spring terminal, "fast connect" quick connection method without stripping
- The signal assignment of the AUX1 bus is specified by the feed to the power module of this potential group.
- Pass-through AUX1 bus with electrical connection to the next potential group to the left
- No access to the AUX1 potential through terminals

**Block diagram**

Block diagram for the TM-P15S22-01, TM-P15C22-01, and TM-P15N22-01 terminal modules

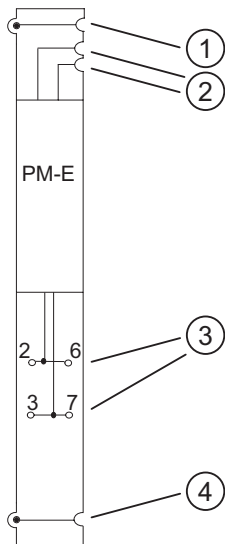

- (1) Backplane bus
- (2) Infeed of the power buses to the electronic modules
- (3) Terminals with connection to the power module
- (4) Uninterrupted AUX1 bus without a connection to the terminals

**TM-P15x22-01 Technical Specifications (6ES7193-4CEx0-0AA0)**

Dimensions and Weight	
Dimensions W × H × D (mm)	
• Screw-type/spring terminals	15 x 119.5 x 43
• Fast Connect	15 x 142 x 43
Weight	Approx. 55 g

## 1.4 TM-P30S44-A0 and TM-P30C44-A0 terminal modules (6ES7193-4CKx0-0AA0)

**Properties**

- Terminal module for fail-safe PM-E F 24 VDC PROFIsafe power modules
- Infeed for a new potential group up to the next TM-P terminal module
- available in two variants: screw terminal, spring terminal
- Wiring of the fail-safe digital outputs of the PM-E F 24 VDC PROFIsafe
- The signal assignment of the AUX1 bus is specified by the feed to the power module of this potential group.
- Interrupted AUX1 bus without electrical connection to the next potential group to the left
- Access to the AUX1 potential through terminals A4 and A8

**Caution**

If high currents occur at DO 2 P and DO 2 M, you must wire terminals 11 and 15 (DO 2 P) and 12 and 16 (DO 2 M) in parallel. Otherwise, the temperature of the terminals cannot be prevented from rising due to the current load.

**Block diagram**

Block diagram of the TM-P30S44-A0 and TM-P30C44-A0 terminal module

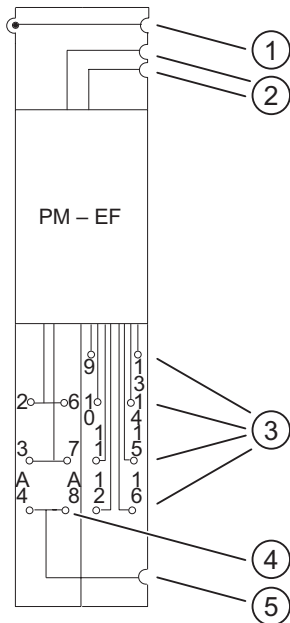

- (1) Backplane bus
- (2) Infeed of the power buses to the electronic modules
- (3) Terminals with connection to the power module
- (4) Use of terminals A4 and A8 as protective conductor terminals or potential terminals of any kind
- (5) Infeed of the AUX1 bus by means of terminals A4 and A8

**TM-P30x44-A0 Technical Specifications (6ES7193-4CKx0-0AA0)**

Dimensions and Weight	
Dimensions W × H × D (mm)	30 x 132 x 43
Weight	Approx. 116 g (TM-P30S44-A0)
	Approx. 100 g (TM-P30C44-A0)

**Description of the PM-E F 24 VDC PROFIsafe power module**

You can find a description of the PM-E F 24 VDC PROFIsafe power module that you can use with the above terminal modules in the *ET 200S Distributed I/O System, Fail-Safe Modules* manual.

## 1.5 TM-PF30S47-F1 terminal module for PM-D F DC24V PROFIsafe (3RK1903-3AA00)

### Properties

- Terminal module for fail-safe PM-D F 24 VDC PROFIsafe power modules
- Infeed for a new potential group up to the next TM-P terminal module
- Available with screw terminal
- The signal assignment of the AUX1 bus is specified by the feed to the power module of this potential group.
- Pass-through AUX1 bus with electrical connection to the next potential group to the left
- No access to the AUX1 potential through terminals

### Block diagram

Block diagram of the TM-PF30S47-F1 terminal module

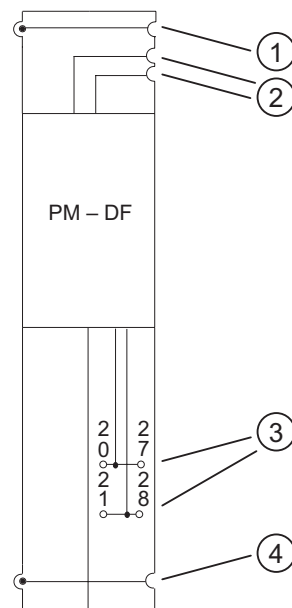

- (1) Backplane bus
- (2) Infeed of the power buses to the electronic modules
- (3) Terminals with connection to the power module
- (4) Uninterrupted AUX1 bus without a connection to the terminals

**TM-PF30S47-F1 Technical Specifications (3RK1903-3AA00)**

Dimensions and Weight	
Dimensions W × H × D (mm)	30 × 196.5 × 102
Weight	Approx. 300 g

**1.6 TM-E15S26-A1, TM-E15C26-A1 and TM-E15N26-A1 universal terminal modules (6ES7193-4CAx0-0AA0)**

**Properties**

- Universal terminal module for all 15 mm wide electronic modules
- Available in two variants: screw terminal, spring terminal, "fast connect" quick connection method without stripping
- The electronic module determines the assignment to terminals 1 to 8.
- Pass-through AUX1 bus with electrical connection to the next potential group to the left
- Access to the AUX1 potential through terminals A4, A8 and A3, A7

**Block diagram**

Block diagram for the TM-E15S26-A1, TM-E15C26-A1, and TM-E15N26-A1 terminal modules

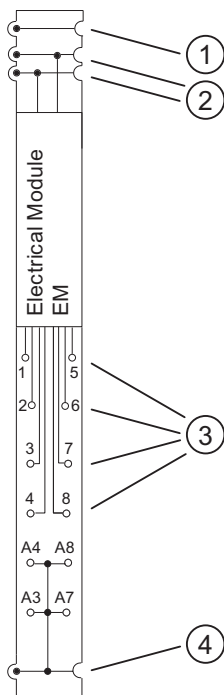



---

 1.7 Terminal module TM-E15S24-A1, TM-E15C24-A1 and TM-E15N24-A1 (6ES7193-4CAx0-0AA0)

- (1) Backplane bus
- (2) Uninterrupted power buses from the power module
- (3) Terminals with connection to the electronic module
- (4) Uninterrupted AUX1 bus with connection to terminals A4, A8 and A3, A7

**TM-P15x26-A1 Technical Specifications (6ES7193-4CAx0-0AA0)**

Dimensions and Weight	
Dimensions W × H × D (mm) <ul style="list-style-type: none"> <li>• Screw-type/spring terminals</li> <li>• Fast Connect</li> </ul>	15 × 157 × 43 15 × 202 × 43
Weight	Approx. 70 g (TM-E15C26-A1) Approx. 83 g (TM-E15S26-A1) Approx. 95 g (TM-E15N26-A1)

## 1.7 Terminal module TM-E15S24-A1, TM-E15C24-A1 and TM-E15N24-A1 (6ES7193-4CAx0-0AA0)

**Properties**

- Terminal module for 15 mm wide electronic modules
- Available in two variants: screw terminal, spring terminal, "fast connect" quick connection method without stripping
- The electronic module determines the signal assignment at terminals 1 to 3 and 5 to 7.
- Pass-through AUX1 bus with electrical connection to the next potential group to the left
- Access to the AUX1 potential through terminals A4 and A8

**Block diagram**

Block diagram for the TM-E15S24-A1, TM-E15C24-A1, and TM-E15N24-A1 terminal modules

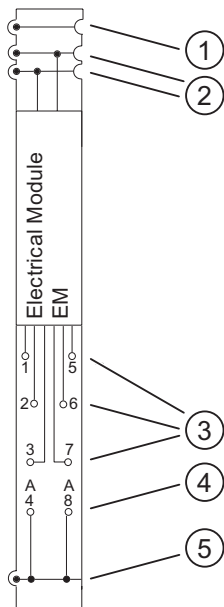

- (1) Backplane bus
- (2) Uninterrupted power buses from the power module
- (3) Terminals with connection to the electronic module
- (4) Use of terminals 4 and 8 as protective conductor terminals or potential terminals of any kind
- (5) Uninterrupted AUX1 bus with connection to terminals A4 and A8

**TM-E15x24-A1 technical specifications (6ES7193-4CAx0-0AA0)**

Dimensions and Weight	
Dimensions W × H × D (mm)	
• Screw-type/spring terminals	15 × 132 × 43
• Fast Connect	15 × 162 × 43
Weight	Approx. 65 g (TM-E15S24-A1 and TM-E15C24-A1) Approx. 72 g(TM-E15N24-A1)

## 1.8 TM-E15S24-01, TM-E15C24-01 and TM-E15N24-01 terminal modules (6ES7193-4CBx0-0AA0)

### Properties

- Terminal module for 15 mm-wide electronic modules
- Available in two variants: screw terminal, spring terminal, "fast connect" quick connection method without stripping
- The electronic module determines the assignment to terminals 1 to 8.
- Pass-through AUX1 bus with electrical connection to the next potential group to the left
- No access to the AUX1 potential through terminals

### Block diagram

Block diagram for the TM-E15S24-01, TM-E15C24-01, and TM-E15N24-01 terminal modules

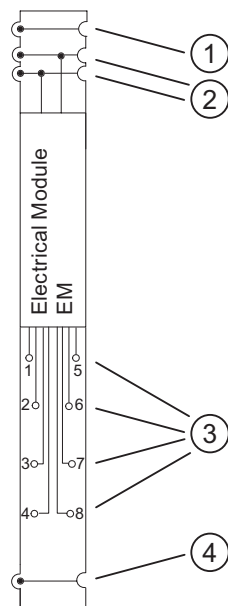

- (1) Backplane bus
- (2) Uninterrupted power buses from the power module
- (3) Terminals with connection to the electronic module
- (4) Uninterrupted AUX1 bus without a connection to the terminals

**TM-E15x24-01 Technical Specifications (6ES7193-4CBx0-0AA0)**

Dimensions and Weight	
Dimensions W × H × D (mm)	
• Screw-type/spring terminals	15 × 132 × 43
• Fast Connect	15 × 162 × 43
Weight	Approx. 65 g (TM-E15S24-01 and TM-E15C24-01) Approx. 72 g (TM-E15N24-01)

**1.9 TM-E15S23-01, TM-E15C23-01 and TM-E15N23-01 terminal modules (6ES7193-4CBx0-0AA0)**

**Properties**

- Terminal module for 15 mm wide electronic modules
- Available in two variants: screw terminal, spring terminal, "fast connect" quick connection method without stripping
- The electronic module determines the signal assignment at terminals 1 to 3 and 5 to 7.
- Pass-through AUX1 bus with electrical connection to the next potential group to the left
- No access to the AUX1 potential through terminals

**Block diagram**

Block diagram for the TM-E15S23-01, TM-E15C23-01, and TM-E15N23-01 terminal modules

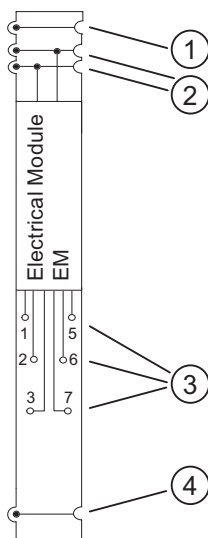

- (1) Backplane bus
- (2) Uninterrupted power buses from the power module
- (3) Terminals with connection to the electronic module
- (4) Uninterrupted AUX1 bus without a connection to the terminals

**TM-E15x23-01 Technical Specifications (6ES7193-4CBx0-0AA0)**

Dimensions and Weight	
Dimensions W × H × D (mm)	
• Screw-type/spring terminals	15 × 120 × 43
• Fast Connect	15 × 142 × 43
Weight	Approx. 55 g (TM-E15S23-01 and TM-E15C23-01) Approx. 60 g (TM-E15N23-01)

**1.10 Terminal module TM-E15S24-AT and TM-E15C24-AT (6ES7193-4CLx0-0AA0)****Properties**

- Terminal module for the 15 mm wide 2AI TC HF terminal module

**Caution**

You can only insert the 2AI TC HF electronic module into the TM-E15S24-AT/TM-E15C24-AT terminal module. Inserting another electronic module can result in the destruction of the internal reference junction of the terminal module.

- The terminal module has an internal reference junction for temperature compensation. Temperature compensation is thus possible directly at the reference junction of the thermocouples.
- available in two variants: screw terminal, spring terminal
- The electronic module determines the signal assignment at terminals 1, 2 and 5, 6.
- Pass-through AUX1 bus with electrical connection to the next potential group to the left
- No access to the AUX1 potential through terminals

**Block diagram**

Block diagram of the TM-E15S24-AT and TM-P15C24-AT terminal module

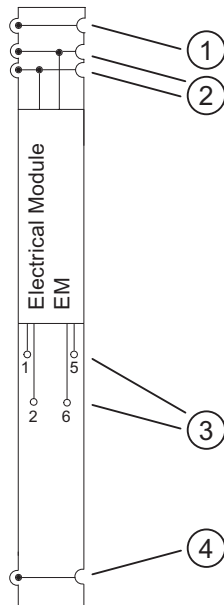

- (1) Backplane bus
- (2) Uninterrupted power buses from the power module
- (3) Terminals with connection to the electronic module
- (4) Uninterrupted AUX1 bus without a connection to the terminals

**TM-E15x24-AT Technical Specifications (6ES7193-4CLx0-0AA0)**

Dimensions and Weight	
Dimensions W × H × D (mm)	15 × 132 × 43
Weight	Approx. 55 g

**See also**

2AI RTD High Feature analog electronic module (6ES7134-4NB01-0AB0) (Page 4-90)

## 1.11 TM-E30S46-A1 and TM-E30C46-A1 universal terminal modules (6ES7193-4CFx0-0AA0)

### Properties

- Universal terminal module for all 30 mm wide electronic modules
- available in two variants: screw terminal, spring terminal
- The electronic module determines the assignment to terminals 1 to 16.
- Pass-through AUX1 bus with electrical connection to the next potential group to the left
- Access to the AUX1 potential via terminals A4, A8, A3, A7 and A12, A16, A11, A15

### Block diagram

Block diagram of the TM-E30S46-A1 and TM-E30C46-A1 terminal module

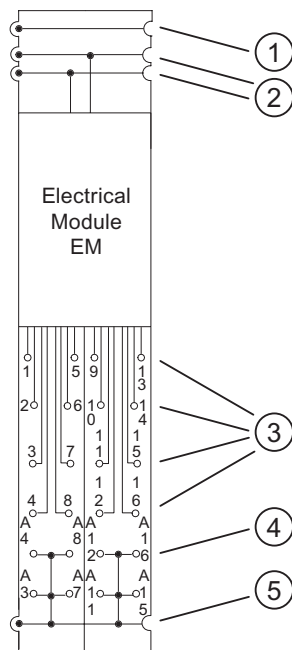

- (1) Backplane bus
- (2) Uninterrupted power buses from the power module
- (3) Terminals with connection to the electronic module
- (4) Connection of terminals A4, A8, A3, A7 and A12, A16, A11, A15 as productive conductor terminals or potential terminals of any kind
- (5) Uninterrupted AUX1 bus with a connection to terminals A4, A3, A8, A7 and A12, A11, A16, A15

**TM-E30x46-A1 Technical Specifications (6ES7193-4CFx0-0AA0)**

Dimensions and Weight	
Dimensions W × H × D (mm)	30 x 157 x 43
Weight	Approx. 158 g (TM-E30S46-A1)
	Approx. 131 g (TM-E30C46-A1)

**Description of the electronic modules**

You can find a description of the 4/8 F-DI 24 VDC PROFIsafe and the 4 F-DO 24 VDC/2 A PROFIsafe electronic modules you can use with the above terminal modules in the *ET 200S Distributed I/O Module, Fail-Safe Modules* manual.



## 1.12 TM-E30S44-01 and TM-E30C44-01 terminal modules (6ES7193-4CGx0-0AA0)

### Properties

- Terminal module for 30 mm wide electronic modules and fail-safe electronic modules
- available in two variants: screw terminal, spring terminal
- The electronic module determines the assignment to terminals 1 to 16.
- Pass-through AUX1 bus with electrical connection to the next potential group to the left
- No access to the AUX1 potential through terminals

### Block diagram

Block diagram of the TM-E30S44-01 and TM-E30C44-01 terminal module

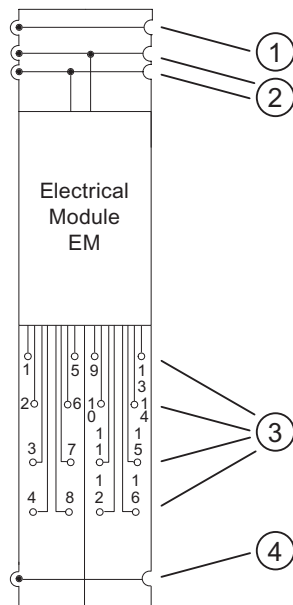

- (1) Backplane bus
- (2) Uninterrupted power buses from the power module
- (3) Terminals with connection to the electronic module
- (4) Uninterrupted AUX1 bus without a connection to the terminals

### TM-E30x44-01 Technical Specifications (6ES7193-4CGx0-0AA0)

Dimensions and Weight	
Dimensions W × H × D (mm)	30 × 132 × 43
Weight	Approx. 110 g (TM-E30C44-01) Approx. 125 g (TM-E30S44-01)

## 1.13 TM-C120S and TM-C120C terminal modules (6ES7193-4DLx0-0AA0)

### Properties

- Terminal module for the COMPACT modules
- available in two variants: screw terminal, spring terminal
- The COMPACT module determines the assignment to terminals 1 to 80.
- Infeed of the power buses to the electronic modules from the last potential group of the COMPACT module
- uninterrupted AUX1 bus
- No access to the AUX1 potential through terminals
- with 40-pin supplementary terminal; any additional required potentials can be applied there

### Block diagram

Block diagram of the TM-C120S and TM-C120C terminal modules

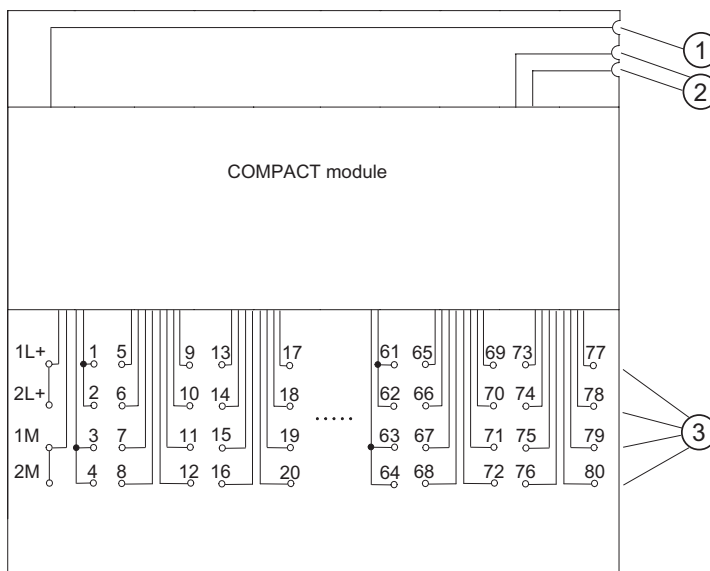

- (1) Backplane bus
- (2) Infeed of the power buses to the electronic modules (from the last potential group of the COMPACT module)
- (3) Terminals with connection to the COMPACT module

### TM-C120x Technical Specifications (6ES7193-4DLx0-0AA0)

Dimensions and Weight	
Dimensions W × H × D (mm)	
• Screw-type/spring terminals	120 × 132 × 43
Weight	Approx. 335 g

## 1.14 TE-U120S4x10 and TE-U120C4x10 supplementary terminal (6ES7193-4FLx0-0AA0)

### Properties

- 40-pin extension for
  - the TM-C terminal module for COMPACT modules
  - any terminal modules with a width of 120 mm
- available in two variants: screw terminal, spring terminal
- Any additionally required potentials can be applied to the supplementary terminal, e.g. with 3 or 4-wire connection of sensors or actuators.
- The four potential groups on the supplementary terminal can be adapted (extended) for the local requirements with pluggable bridges.

### Extending the potential groups

The supplementary terminal is fitted with three pluggable bridges on delivery.

If it is necessary to apply more than one potential to the supplementary terminal, the potential groups on the supplementary terminal can be extended. This is done with pluggable bridges that connect two or more groups. After removal of corresponding bridges terminals are available for additional potentials.

Table 1-1 Potential groups on the supplementary terminal

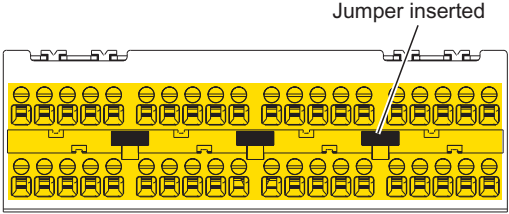
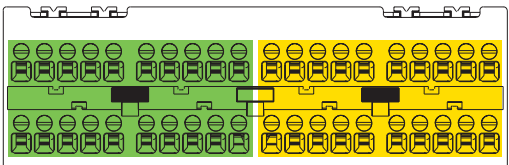
Quantity		Position on the supplementary terminal
inserted bridges	Potential groups	
3 <sup>1</sup>	1	 <p>Jumper inserted</p>
2	2	

1.14 TE-U120S4x10 and TE-U120C4x10 supplementary terminal (6ES7193-4FLx0-0AA0)

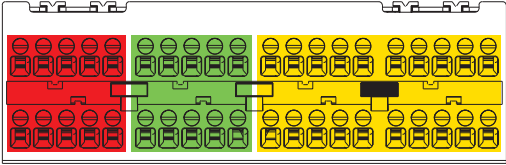
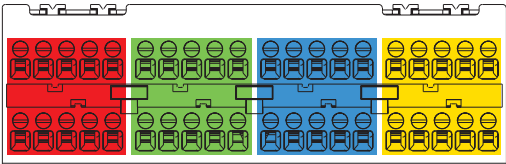
Quantity		Position on the supplementary terminal
inserted bridges	Potential groups	
1	3	
None	4	
<sup>1</sup> Delivery status		

TE-U120x4x10 Technical Specifications (6ES7193-4FLx0-0AA0)

Dimensions and Weight	
Dimensions W × H × D (mm)	
<ul style="list-style-type: none"> <li>Screw-type/spring terminals</li> <li>with mounting bracket</li> </ul>	120 × 38 × 30 120 × 79 × 30
Weight	Approx. 160 g
Terminal-specific data	
Connectable potentials	Up to 230 VAC
Current-carrying capacity (from supplementary terminal and pluggable bridges)	10 A

## Power modules

### 2.1 Configuring the address space

#### Address area for option handling and status byte

You can control and monitor option handling, and evaluate the status byte of the power module using the control (PIQ) and feedback interface (PII).

The address range of the control (PIQ) and feedback interface (PII) depends on the configuration or selection of the corresponding entry in the configuration software.

This table shows the PII feedback interface and the PIQ control interface for different entries.

Table 2-1 PII feedback interface and PIQ control interface

with STEP 7, HW Config or COM PROFIBUS or other configuration software	Feedback interface PII		Control interface PIQ	
Usual entry for the power module	---		---	
Ends in ...S	IBx	Status byte	---	
Ends in ...O	IBx ::: IBx+7	Option handling	QBx ::: QBx+7	Option handling
Ends in ...SO	IBx ::: IBx+7	Option handling	QBx ::: QBx+7	Option handling
	IBx+8	Status byte	QBx+8	not applicable

Status byte power modules

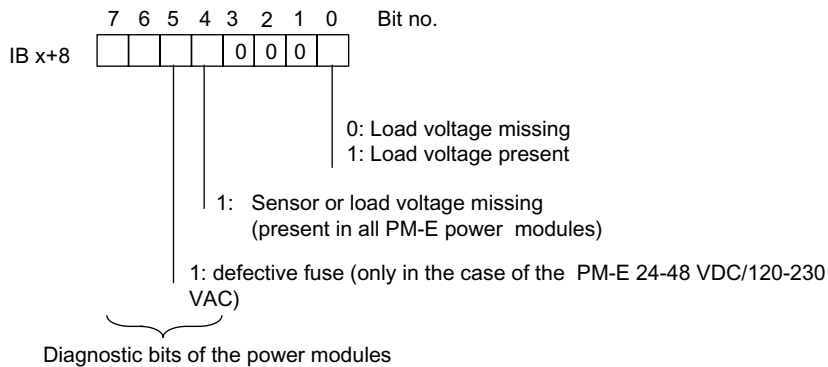

Figure 2-1 Assignment of status byte for power modules

## 2.2 Parameters for power modules

### Parameters

The following table lists the power module parameters.

Table 2-2 Parameters for power modules

Power module			Range of values	Default setting	Applicability
PM-E 24 VDC	PM-E 24 to 48 VDC	PM-E 24 to 48 VDC/ 24 to 230 VAC <sup>1</sup>			
Diagnostics: No load voltage	Diagnostics: No load voltage	Diagnostics: No load voltage	enable/disable	disable	Power module
---	---	Diagnostics: Fuse blown	enable/disable	disable	Power module
---	---	Voltage type	DC/AC	DC	Power module

<sup>1</sup> The PM-E 24 VDC to 48 VDC, 24 VAC to 230 VAC power module (6ES7138-4CB10-0AB0) is not a direct replacement for the device with the order number 6ES7138-4CB00-0AB0 for AC applications because you have to select either AC or DC supply voltage. In the case of DC applications, the new module is a direct replacement because the default setting of the new parameter is "DC". If you want to replace the device 6ES7138-4CB00-0AB0 in AC applications, you have to create a new hardware configuration and set the value "AC" for the load voltage type parameter.

Here is a more detailed explanation of the parameters.

### Diagnostics: No load voltage

Use this parameter to enable a diagnostic message because of missing load voltage.

If there is no load voltage only the diagnostic message of the affected power module is sent to the DP master. The SF error LEDs of all modules in the relevant potential group light.

### Diagnostics: Fuse blown

Use this parameter to enable a diagnostic message because of a blown fuse.

If a fuse has blown only the diagnostic message of the affected power module is sent to the DP master. The SF error LEDs of all modules in the relevant potential group light.

### Voltage type

Use this parameter to select the load voltage that is connected to the power module: direct voltage or alternating voltage.

If the load voltage fails or a fuse blows the correct diagnosis is returned.

## 2.3 PM-E 24 VDC power module (6ES7138-4CA01-0AA0)

### Properties

- The PM-E 24 VDC power module monitors the supply voltage for all the electronic modules in the potential group. The supply voltage is fed in by means of the TM-P terminal module.
- You can use any electronic module in the potential group of the PM-E 24 VDC power module except the 2DI 120 VAC Standard, 2DI 230 VAC Standard and 2DO 24 VAC to 230 VAC/1 A.
- The current status of the power module is stored in the status byte in the process input image (PII). This is updated irrespective of whether the "No Load Voltage" diagnosis has been enabled.
- The PM-E 24 VDC to 48 VDC power module is suitable for fail-safe modules.



---

#### Caution

Only connect the specified rated load voltage of 24 VDC to the TM-P terminal module of the power module.

The connected rated load voltage must correspond to the supply voltage of the electronic modules in the voltage group.

---

**General terminal assignment**

**Note**

Terminals A4 and A8 are only available at specified terminal modules.

Terminal assignment for PM-E 24 VDC (6ES7138-4CA01-0AA0)				
Terminal	Assignment	Terminal	Assignment	Notes
2	L+	6	L+	<ul style="list-style-type: none"> <li>L+ Rated load voltage 24 VDC</li> <li>M: Ground</li> <li>AUX1: Protective-conductor terminal or potential bus (freely usable up to 230 VAC)</li> </ul>
3	M	7	M	
A4	AUX1	A8	AUX1	

**Usable terminal modules**

Usable terminal modules for PM-E 24 VDC (6ES7138-4CA01-0AA0)			
TM-P15C23-A1 (6ES7193-4CC30-0AA0)	TM-P15C23-A0 (6ES7193-4CD30-0AA0)	TM-P15C22-01 (6ES7193-4CE10-0AA0)	← Spring terminal
TM-P15S23-A1 (6ES7193-4CC20-0AA0)	TM-P15S23-A0 (6ES7193-4CD20-0AA0)	TM-P15S22-01 (6ES7193-4CE00-0AA0)	← Screw terminal
TM-P15N23-A1 (6ES7193-4CC70-0AA0)	TM-P15N23-A0 (6ES7193-4CD70-0AA0)	TM-P15N22-01 (6ES7193-4CE60-0AA0)	← Fast Connect
			<p>Wiring examples</p>



## Block diagram

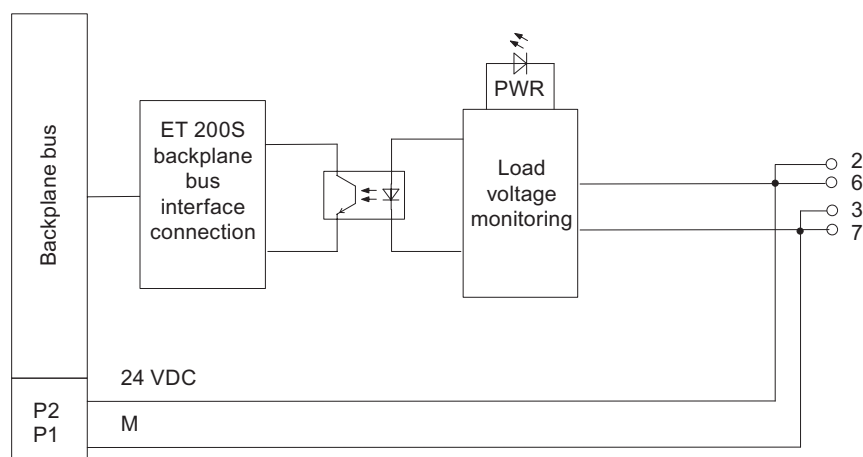

Figure 2-2 Block diagram of the PM-E 24 VDC power module

## PM-E 24 VDC power module technical specifications (6ES7138-4CA01-0AA0)

Dimensions and Weight	
Dimensions W × H × D (mm) (the total dimensions depend on the selected terminal module)	15 × 81 × 52
Weight	Approx. 35 g
Voltages, currents, potentials	
Rated load voltage	24 VDC
• Overvoltage protection	no
Protection with automatic circuit breakers	yes, tripping characteristic B, C
Max. current-carrying capacity (up to 60° C)	10 A
• Short-circuit protection	no
Galvanic isolation	
• Between rated load voltage and backplane bus	Yes
• Between the power modules	Yes
Insulation test voltage	500 VDC
Current consumption	
• From the load voltage L+ (no load)	max. 4 mA
Power dissipation of the module	typ. 100 mW
Parameter length	3 bytes
Status, interrupts, diagnostics	
Diagnostic function	Yes
• General fault	Red "SF" LED
• Load voltage monitoring	Green "PWR" LED
• Diagnostic information readable	Yes

## 2.4 PM-E 24-48 VDC power module (6ES7138-4CA50-0AA0)

### Properties

- The PM-E 24 VDC to 48 VDC power module monitors the supply voltage for all the electronic modules in the voltage group. The supply voltage is fed in by means of the TM-P terminal module.
- You can use all the electronic modules except the 2DI 120 VAC Standard, 2DI 230 VAC Standard, and 2DO 24 VAC to 230 VAC/1 A in the voltage group of the PM-E 24 VDC to 48 VDC power module.
- Control interface (PIQ) and feedback interface (PII) in the process image for option handling.
- The current status of the power module is stored in the status byte in the process input image (PII). This is updated irrespective of whether the "No Load Voltage" diagnosis has been enabled.
- The PM-E 24 VDC to 48 VDC power module is suitable for fail-safe modules.



### Caution

Only connect the specified rated load voltage of 24 VDC to 48 VDC to the TM-P terminal module of the power module.

The connected rated load voltage must correspond to the supply voltage of the electronic modules in the voltage group.

### General terminal assignment

#### Note

Terminals A4 and A8 are only available at specified terminal modules.

Terminal assignment for PM-E 24 VDC to 48 VDC (6ES7138-4CA50-0AA0)				
Terminal	Assignment	Terminal	Assignment	Notes
2	L+	6	L+	<ul style="list-style-type: none"> <li>• L+ Rated load voltage 24 VDC to 48 VDC</li> <li>• M: Ground</li> <li>• AUX1: Protective-conductor terminal or potential bus (freely usable up to 230 VAC)</li> </ul>
3	M	7	M	
A4	AUX1	A8	AUX1	

Usable terminal modules

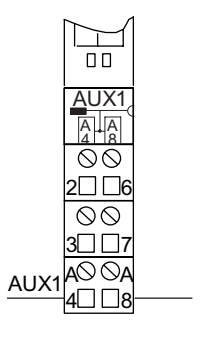
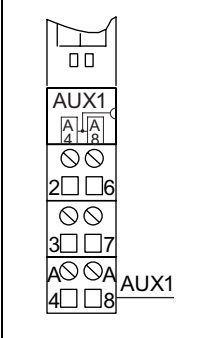
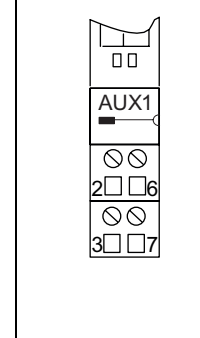
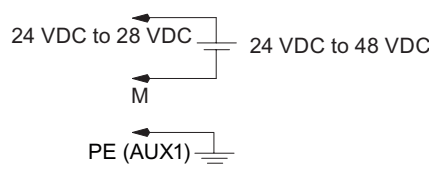
Usable terminal modules for PM-E 24-48 VDC (6ES7138-4CA50-0AA0)			
TM-P15C23-A1 (6ES7193-4CC30-0AA0)	TM-P15C23-A0 (6ES7193-4CD30-0AA0)	TM-P15C22-01 (6ES7193-4CE10-0AA0)	← Spring terminal
TM-P15S23-A1 (6ES7193-4CC20-0AA0)	TM-P15S23-A0 (6ES7193-4CD20-0AA0)	TM-P15S22-01 (6ES7193-4CE00-0AA0)	← Screw terminal
TM-P15N23-A1 (6ES7193-4CC70-0AA0)	TM-P15N23-A0 (6ES7193-4CD70-0AA0)	TM-P15N22-01 (6ES7193-4CE60-0AA0)	← Fast Connect
			<p>Wiring examples</p> 

Block diagram

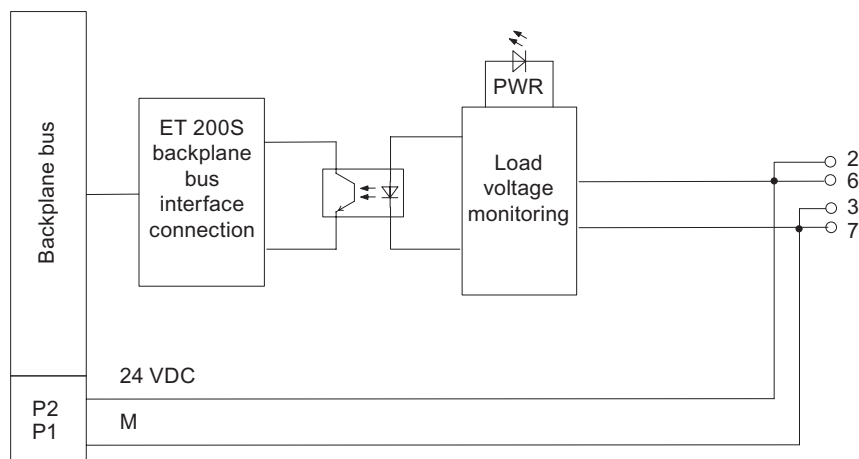

Figure 2-3 Block diagram of the PM-E 24 VDC to 48 VDC power module

**PM-E 24 VDC to 48 VDC technical specifications (6ES7138-4CA50-0AA0)**

<b>Dimensions and Weight</b>	
Dimensions W × H × D (mm) (the total dimensions depend on the selected terminal module)	15 × 81 × 52
Weight	Approx. 35 g
<b>Voltages, currents, potentials</b>	
Rated load voltage	24 VDC to 48 VDC
• Reverse polarity protection	Yes
• Overvoltage protection	no
Protection with automatic circuit breakers	yes, tripping characteristic B, C
Max. current-carrying capacity (up to 60° C)	10 A
• Short-circuit protection	no
Galvanic isolation	
• Between rated load voltage and backplane bus	Yes
• Between the power modules	Yes
Insulation test voltage	500 VDC
Current consumption	
• From the load voltage L+ (no load)	max. 12 mA
Power dissipation of the module	typ. 500 mW
Parameter length	3 bytes
<b>Status, interrupts, diagnostics</b>	
Diagnostic function	Yes
• Group error	Red "SF" LED
• Load voltage monitoring	Green "PWR" LED
• Diagnostic information readable	Yes

**Reference**

Information on the address space of the inputs and outputs can be found in the *ET 200S Operating Instructions*.

## 2.5 PM-E 24-48 VDC/24-230 VAC power module (6ES7138-4CB10-0AB0)

### Properties

The PM-E 24 VDC to 48 VDC/24 VAC to 230 VAC power module

- Monitors the supply voltage for all the electronic modules in the voltage group. The supply voltage is fed in by means of the TM-P terminal module.
- Can be used universally and can be assigned parameters for DC and AC load voltage for use with any electronic module.
- Is required at least once for the ET 200S (to the right of the interface module).  
Exception: structure of the ET 200S with an IM151-1 COMPACT
- Control interface (PIQ) and feedback interface (PII) in the process image for option handling.
- The current status of the power module is stored in the status byte in the process input image (PII). This is updated irrespective of whether the "No Load Voltage" diagnosis has been enabled.
- Is additionally equipped with a replaceable fuse (5 mm x 20 mm).

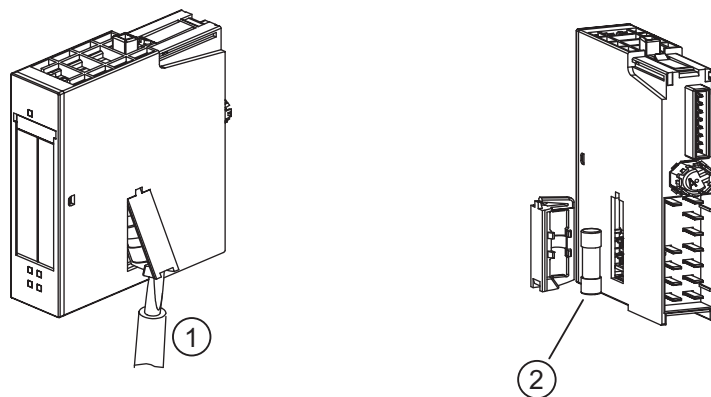

Figure 2-4 Replacing the fuse

- (1) 3-mm screwdriver
- (2) Backup

**General terminal assignment**

**Note**

Terminals A4 and A8 are only available at specified terminal modules.

PM-E 24 VDC to 48 VDC/24 VAC to 230 VAC terminal assignment (6ES7138-4CB10-0AB0)				
Terminal	Assignment	Terminal	Assignment	Notes
2	L+/L1	6	L+/L1	<ul style="list-style-type: none"> <li>L+/L1: Rated load voltage 24 VDC to 48 VDC</li> <li>M: Ground</li> <li>N: Neutral conductor</li> <li>AUX1: Protective-conductor terminal or potential bus (freely usable up to 230 VAC)</li> </ul>
3	M/N	7	M/N	
A4	AUX1	A8	AUX1	

**Usable terminal modules**

PM-E 24 VDC to 48 VDC/24 VAC to 230 VAC terminal modules can be used (6ES7138-4CB10-0AB0)			
TM-P15C23-A1 (6ES7193-4CC30-0AA0)	TM-P15C23-A0 (6ES7193-4CD30-0AA0)	TM-P15C22-01 (6ES7193-4CE10-0AA0)	← Spring terminal
TM-P15S23-A1 (6ES7193-4CC20-0AA0)	TM-P15S23-A0 (6ES7193-4CD20-0AA0)	TM-P15S22-01 (6ES7193-4CE00-0AA0)	← Screw terminal
TM-P15N23-A1 (6ES7193-4CC70-0AA0)	TM-P15N23-A0 (6ES7193-4CD70-0AA0)	TM-P15N22-01 (6ES7193-4CE60-0AA0)	← Fast Connect
			<p>Wiring examples</p>

## Block diagram

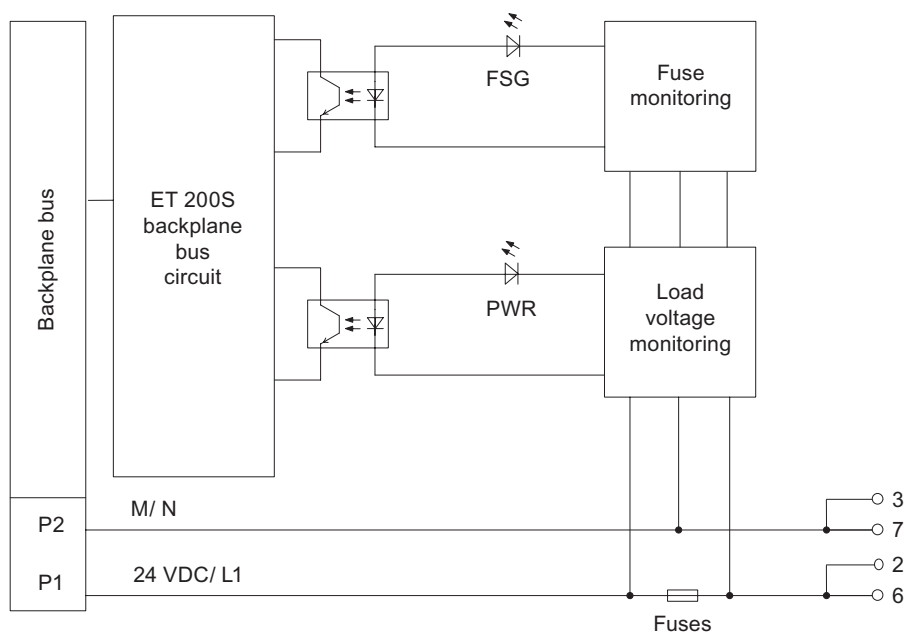

Figure 2-5 Block diagram of the PM-E 24-48 VDC, 24-230 VAC

## PM-E 24 VDC to 48 VDC/24 VAC to 230 VAC technical specifications (6ES7138-4CB10-0AB0)

Dimensions and Weight	
Dimensions W × H × D (mm) (the total dimensions depend on the selected terminal module)	15 × 81 × 52
Weight	34 g
Voltages, currents, potentials	
Rated load voltage	24 VDC to 56.7 VDC 24 VAC to 48 VAC/120 VAC/230 VAC
• Overvoltage protection	Yes
Protection with automatic circuit breakers	yes, tripping characteristic B, C
Max. current-carrying capacity	10 A
• For 24-56.7 VDC	up to 30 °C: max. 10 A up to 40 °C: max. 9 A up to 60 °C: max. 7 A
• For 24-48/120/230 VAC	up to 30 °C: max. 8 A up to 40 °C: max. 7 A up to 60 °C: max. 5 A
• Short-circuit protection	yes, IEC 127-2/1, 250 V, 10 A, fast fuse (5 x 20 mm), replaceable <sup>1</sup>
Galvanic isolation	
• Between rated load voltage and backplane bus	Yes
• Between the power modules	Yes
Insulation test voltage	1500 VAC
Current consumption from backplane bus	max. 9.5 mA

2.6 Placing power modules and connecting them to common potential

• From load voltage L1/L+ (no load)	max. 9 mA
Power dissipation of the module	max. 5 W
Parameter length	3 bytes
<b>Status, interrupts, diagnostics</b>	
Diagnostic function	Yes
• Group error	Red "SF" LED
• Load voltage monitoring	Green "PWR" LED
• Backup	Green "FSG" LED
• Diagnostic information can be displayed	Yes
<sup>1</sup> The fuses on this module are only additional fuses. External overcurrent protection (suitable for branch circuits in accordance with the applicable national regulations for electrical engineering) is required in the supply lines of the load circuit.	

Reference

Information on the address space of the inputs and outputs can be found in the *ET 200S Operating Instructions*.

## 2.6 Placing power modules and connecting them to common potential

### Placing and Connecting to Common Potential

You can choose where to position the power modules in the ET 200S. Every TM-P terminal module (for a power module) that you install in the ET 200S opens a new voltage group. All sensor and load supplies of the downstream electronic modules are fed from this TM-P terminal module (for a power module). If you place an additional TM-P terminal module after an electronic module/motor starter, you interrupt the potential buses (P1/P2) and simultaneously open a new voltage group. This enables sensor and load supplies to be individually connected to common potential.

### AUX(iliary) bus (AUX1)

A TM-P terminal module (for a power module) allows you to connect additional potential (up to the maximum rated load voltage of the module), which you can apply by means of the AUX(iliary) bus.

You can set the AUX(iliary) bus individually:

- As a protective conductor bar
- For additionally required voltage

The AUX1 bus is laid out as follows:

- Maximum current-carrying capacity (at 60 °C ambient temperature): 10 A
- Permitted voltage: 230 VAC/DC



Placing power modules and connecting them to common potential

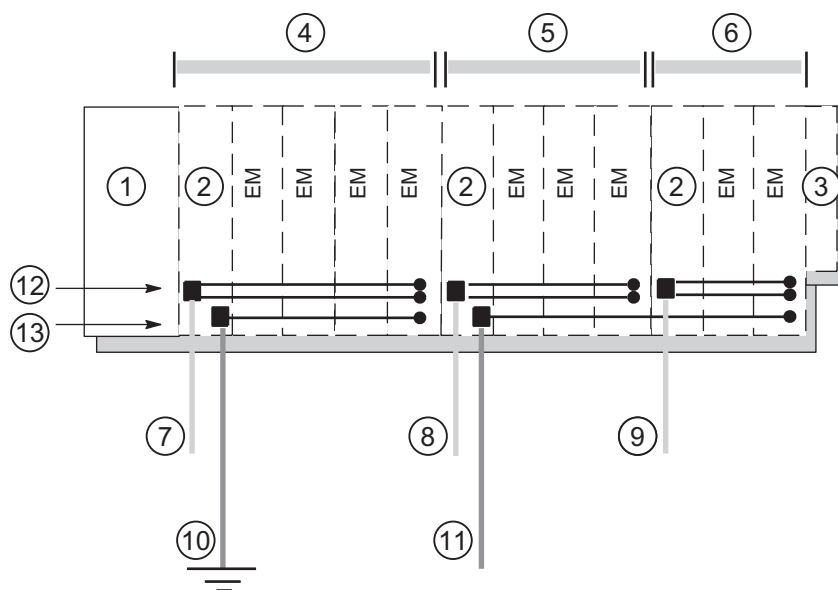

- |   |                    |   |                               |
|---|--------------------|---|-------------------------------|
| ① | Interface module   | ⑧ | Supply voltage 2              |
| ② | Power module       | ⑨ | Supply voltage 3              |
| ③ | Terminating module | ⑩ | Protective conductor          |
| ④ | Voltage group 1    | ⑪ | Additionally required voltage |
| ⑤ | Voltage group 2    | ⑫ | P1/P2 power buses             |
| ⑥ | Voltage group 3    | ⑬ | AUX1 bus                      |
| ⑦ | Supply voltage 1   |   |                               |



**Warning**

If you connect the AUX1 bus to common potential independently of the P1/P2 buses (different voltages), there is no safe electrical separation between the AUX1 bus and the P1/P2 buses.

Connecting different potentials to the AUX1 bus

**Note**

If you apply different potentials to the AUX1 bus within an ET 200S station, you must separate the voltage groups by means of a power module with the TM-P15S23-A0 terminal module.

## 2.7 Example of a configuration: Terminal modules for power modules

### Introduction

The following table shows how terminal modules for power modules can be used:

Table 2-3 Terminal modules for power modules

Terminal module	Design
TM-P15S22-01 TM-P15C22-01 TM-P15N22-01	<p>Potential group 1      Potential group 2</p> <p>Backplane bus P1 P2</p> <p>PM EM EM EM PM EM EM EM EM EM</p> <p>2 6 3 7</p> <p>AUX1</p>
TM-P15S23-A1 TM-P15C23-A1 TM-P15N23-A1	<p>Potential group 1      Potential group 2</p> <p>Backplane bus P1 P2</p> <p>PM EM EM EM PM EM EM EM EM EM</p> <p>2 6 3 7 4 8</p> <p>AUX1 (PE)</p> <p>Access by means of terminals to AUX1</p>

Terminal module	Design
TM-P15S23-A0 TM-P15C23-A0 TM-P15N23-A0	<p>Potential group 1    Potential group 2</p> <p>Backplane bus P1 P2</p> <p>PM EM EM EM PM EM EM EM EM EM</p> <p>2 6 3 7 A A 4 8</p> <p>AUX1</p> <p>Access by means of terminals to AUX1</p> <p>Open new potential group by means of AUX1</p>
TM-P30S44-A0 TM-P30C44-A0	<p>Potential group 1    Potential group 2</p> <p>Backplane bus P1 P2</p> <p>PM EM PM EM</p> <p>1 5 2 6 3 7 A A 4 8</p> <p>AUX1</p> <p>Access by means of terminals to AUX1</p> <p>Open new potential group by means of AUX1</p>

2.8 Finding the correct power module for an I/O device

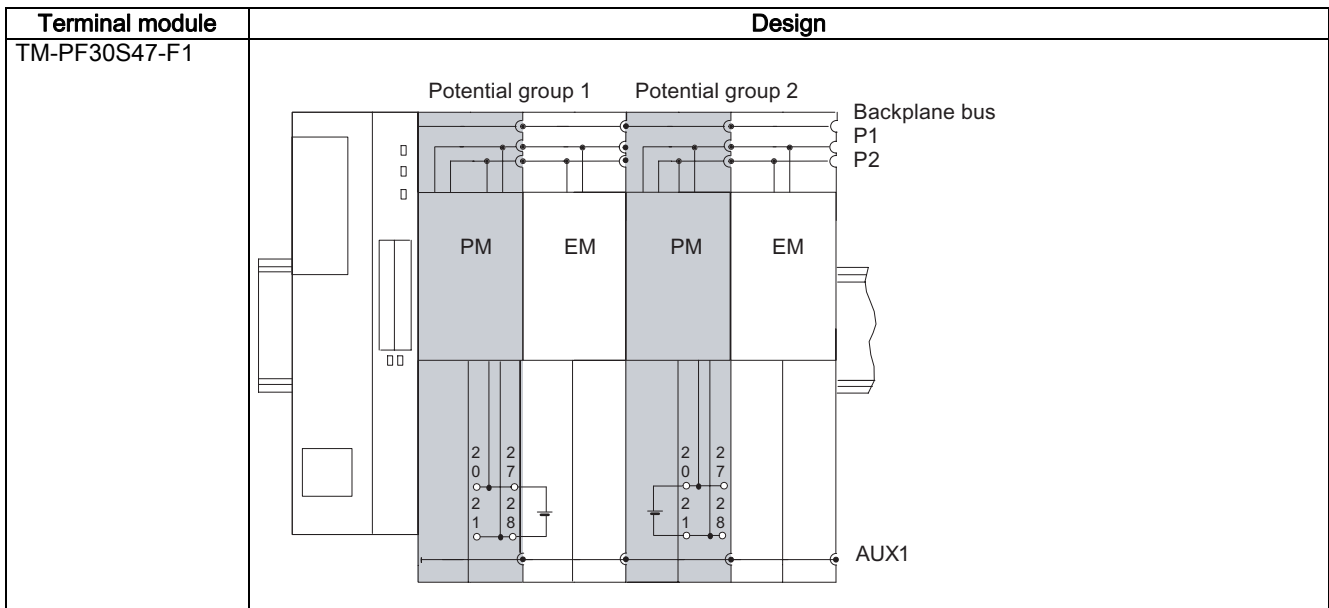

## 2.8 Finding the correct power module for an I/O device

### Applicability of power modules

The following table describes which power modules you can use with the different I/O modules:

Power modules	I/O modules
PM-E 24 VDC	Can be used with all electronic modules except the 120 VAC Standard, 2DI 230 VAC Standard, and 2DO 120/230 VAC.
PM-E 24 VDC to 48 VDC	Applicable <ul style="list-style-type: none"> <li>• Can be used with all electronic modules except the 2DI 120 VAC Standard, 2DI 230 VAC Standard, and 2DO 120 VAC/230 VAC.</li> <li>• For UC electronic modules if the maximum load voltage is 24 VDC and AC is not required</li> </ul>
PM-E 24 VDC to 48 VDC/24 VAC to 230 VAC	Can be used with all electronic modules.
PM-E F pm 24 VDC PROFIsafe	For the fail-safe modules.
PM-E F pp 24 VDC PROFIsafe	See the <i>ET 200S Distributed I/O System Fail-Safe Modules</i> manual
PM-E F 24 VDC PROFIsafe	
PM-D	For motor starters and frequency converters. See <i>ET 200S Motor Starter</i> manual <i>ET 200S FC Frequency Converter</i> operating instructions
PM-D F	For fail-safe applications with motor starter or frequency converter. See <i>ET 200S Motor Starter</i> manual <i>ET 200S FC Frequency Converter</i> operating instructions

## Digital electronic modules

### 3.1 Parameters for digital electronic modules

#### 3.1.1 Parameters for digital input modules

This table shows the parameters for digital input modules:

Table 3-1 Parameters for digital input modules

2DI 24 VDC High Feature	4DI 24 VDC High Feature	4DI 24 to 48 VUC High Feature	2DI/ 4DI 24 VDC Standard 4DI 24 VDC/SRC Standard 2DI 120 VAC Standard 4DI 230 VAC Standard	Range of values	Default setting	Applicability
		---	---	<ul style="list-style-type: none"> <li>• disable</li> <li>• Enable</li> </ul>	disable	Module
---		Diagnostic interrupt	---	<ul style="list-style-type: none"> <li>• disable</li> <li>• Enable</li> </ul>	disable	Module
Input delay <sup>1</sup>		---	---	<ul style="list-style-type: none"> <li>• 0.1 ms</li> <li>• 0.5 ms</li> <li>• 3 ms</li> <li>• 15 ms</li> </ul>	3 ms	Module
Diagnostics: Short-circuit to M <sup>2</sup>		---	---	<ul style="list-style-type: none"> <li>• disable</li> <li>• Enable</li> </ul>	disable	Module
---		Diagnostics: Wire break <sup>4</sup>	---	<ul style="list-style-type: none"> <li>• disable</li> <li>• Enable</li> </ul>	disable	Module
---		Diagnostics: Blown fuse	---	<ul style="list-style-type: none"> <li>• disable</li> <li>• Enable</li> </ul>	disable	Module
---		Diagnostics: No load voltage	---	<ul style="list-style-type: none"> <li>• disable</li> <li>• Enable</li> </ul>	disable	Module

3.1 Parameters for digital electronic modules

2DI 24 VDC High Feature	4DI 24 VDC High Feature	4DI 24 to 48 VUC High Feature	2DI/ 4DI 24 VDC Standard 4DI 24 VDC/SRC Standard 2DI 120 VAC Standard 4DI 230 VAC Standard	Range of values	Default setting	Applicability
Trigger for hardware interrupt, rising edge <sup>3</sup>	Trigger for hardware interrupt, rising edge <sup>3</sup>	---	---	<ul style="list-style-type: none"> <li>• disable</li> <li>• Enable</li> </ul>	disable	Channel 0
---						Channel 1
						Channel 2
						Channel 3

<sup>1</sup> The input delay applies to "0" to "1" and to "1" to "0".

<sup>2</sup> Short circuit of the sensor supply.

<sup>3</sup> Can only be assigned parameters for the IM151-1 High Feature interface module and the IM151-7 CPU

<sup>4</sup> If the wire break check is activated, all the unused inputs must be stabilized to prevent them from triggering a module wire break. To do this, connect a resistor between terminal 24/48 V (3, A4, 7, A8) and the free input. The resistor must provide at least 0.5 mA of input current (see "Sensor Switching" in the table of technical specifications). This ensures that sufficient current is flowing to prevent wire break detection.

The sensor must supply at least 0.5 mA when switched off (otherwise wire break will be detected when switched off). Alternatively, a resistor can be connected parallel to the sensor terminals (the current must be at least 0.5 mA).

3.1.2 Parameters for 4DI NAMUR

This table shows the parameters for 4DI NAMUR:

Table 3-2 Parameters for 4DI NAMUR

4DI NAMUR	Range of values	Default setting	Applicability
Diagnostic interrupt	<ul style="list-style-type: none"> <li>• Enable</li> <li>• disable</li> </ul>	disable	Module
Encoder type	<ul style="list-style-type: none"> <li>• Channel disabled</li> <li>• NAMUR sensor</li> <li>• Open single contact</li> <li>• Single contact, closed, with 10 kΩ</li> <li>• NAMUR changeover contact</li> <li>• Open changeover contact</li> <li>• Changeover contact, closed, with 10 kΩ</li> </ul>	Channel disabled	Channel
Pulse stretching	<ul style="list-style-type: none"> <li>• None</li> <li>• 0.5 s</li> <li>• 1 s</li> <li>• 2 s</li> </ul>	None	Channel
Diagnostics	<ul style="list-style-type: none"> <li>• Enable</li> </ul>	disable	Module

4DI NAMUR	Range of values	Default setting	Applicability
No sensor supply	<ul style="list-style-type: none"> <li>disable</li> </ul>		
Diagnostics: wire break	<ul style="list-style-type: none"> <li>Enable</li> <li>disable</li> </ul>	disable	Channel
Diagnostics: wire break	<ul style="list-style-type: none"> <li>Enable</li> <li>disable</li> </ul>	disable	Channel
Chatter monitoring: Monitoring window <sup>1</sup>	<ul style="list-style-type: none"> <li>0.5 s</li> <li>1 s to 100 s (can be set at increments of 1 s)</li> </ul>	0.5 s	Channel
Chatter monitoring: Number of signal changes	<ul style="list-style-type: none"> <li>disable</li> <li>2 to 31</li> </ul>	disable	Channel

<sup>1</sup> The parameters can only be set when the number of signal changes for chatter monitoring is activated

### 3.1.3 Parameters for digital output modules

This table shows the parameters for digital output modules:

Table 3-3 Parameters for digital output modules

2DO 24 VDC/0.5 A High Feature	2DO 24 VAC to 230 VAC/1 A	2RO NO NC 24-48 VDC/5 A 24-230 VAC/ 5 A	2DO/ 4DO 24 VDC/0.5 A Standard	Range of values	Default setting	Applicability	
2DO 24 VDC/2 A High Feature	2RO NO 24 VDC to 120 VDC/5 A 24 VAC to 230 VAC/5 A		2DO/ 4DO 24 VDC/2 A Standard				
Reaction to CPU-/master-STOP				---	<ul style="list-style-type: none"> <li>Substitute a value</li> <li>Keep last value</li> </ul>	Substitute a value	Module
Substitute value <sup>1</sup>				---	<ul style="list-style-type: none"> <li>"0"</li> <li>"1"</li> </ul>	"0"	Channel
Diagnostics: Wire break <sup>2</sup>	---			<ul style="list-style-type: none"> <li>disable</li> <li>Enable</li> </ul>	disable	Channel	
Diagnostics: Short-circuit to M	---			<ul style="list-style-type: none"> <li>disable</li> <li>Enable</li> </ul>	disable	Channel	

<sup>1</sup> If the interface module or COMPACT module becomes deenergized, the digital output modules will not produce substitute values.  
Output value = 0.

<sup>2</sup> A wire break is only detected in the switched output state.

## **3.2 Parameters of the Digital Electronic Modules**

### **3.2.1 Hardware interrupt**

This parameter enables the hardware interrupts for the module.

### **3.2.2 Input delay**

This parameter can be used to suppress signal interference. Changes in the signal are only detected if they remain stable for longer than the configured input delay time.

### **3.2.3 Trigger for hardware interrupt, rising edge**

This parameter can be used to enable a hardware interrupt with rising edge (a signal status change) by channel.



### 3.2.4 Pulse stretching

#### Definition

The pulse stretching is a function used to modify a digital input signal. A pulse at a digital input is stretched to at least the length set in the parameters. If the input pulse is already longer than the selected length, it is not changed

#### Principle of Pulse Stretching

The figure below shows a few examples of input pulse modification.

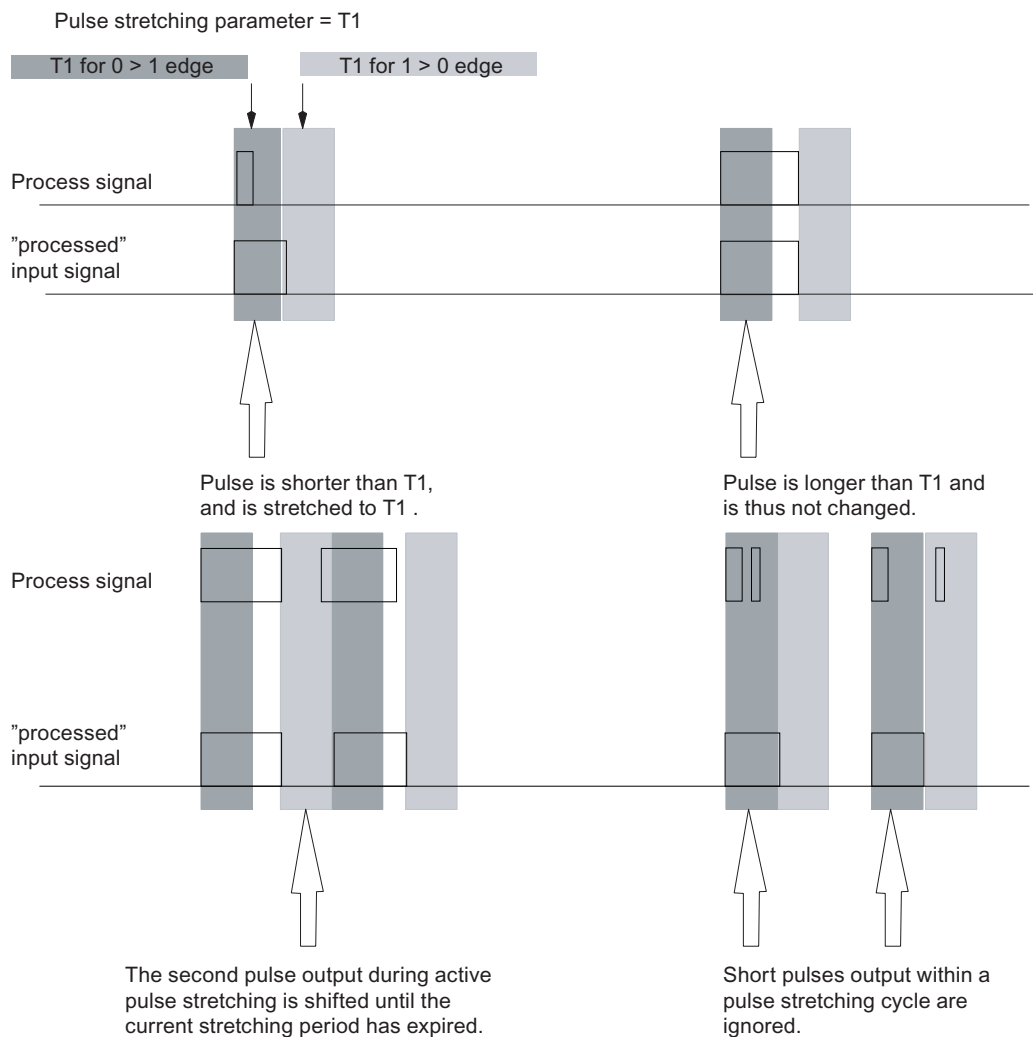

Figure 3-1 Principle of Pulse Stretching

---

**Note**

If you set pulse stretching for an input channel, this also affects the flutter monitoring enabled for this channel. The "pulse stretched" signal is the input signal for flutter monitoring. You should therefore adapt the pulse stretching parameters and flutter monitoring functions to each other. Select appropriate parameter values in order to tune the functions to your process.

---

### 3.2.5 Chatter monitoring

#### Definition

Chatter monitoring is a process control function for digital input signals. It detects and reports signal characteristics that are unusual from a process engineering viewpoint, such as the input signal fluctuating too frequently between "0" and "1". If signal characteristics like these occur, it is a sign that the sensors are faulty or that there are instabilities from a process engineering viewpoint.

#### Activating chatter monitoring

You activate chatter monitoring by setting the number of signal changes for chatter monitoring to a value other than zero.

#### Detecting unusual signal patterns

Each input channel has a monitoring window that has been assigned parameters. The monitoring window is started the first time the input signal changes. If the input signal changes more within the monitoring window than the configured number of signal changes, this is recognized as a flutter error. If a flutter error is not detected within the monitoring window, the monitoring window is started again at the next signal change.

#### Reporting a chatter error

If a chatter error has occurred, the current signal status is entered in the process image and the value of the signal is set to "invalid". A chatter error is also entered as diagnostic information, triggering an incoming diagnostic interrupt.

You must evaluate and process the status of the value and the diagnostic information in the user program.

#### Resetting a chatter error

If no further chattering of the input signal is detected within three monitoring windows, the diagnostic entry is removed and an outgoing diagnostic interrupt is triggered. The status of the value of the current signal in the process image is set to "valid".

## Principles

The following figure gives you another graphic illustration of the principle of chatter monitoring.

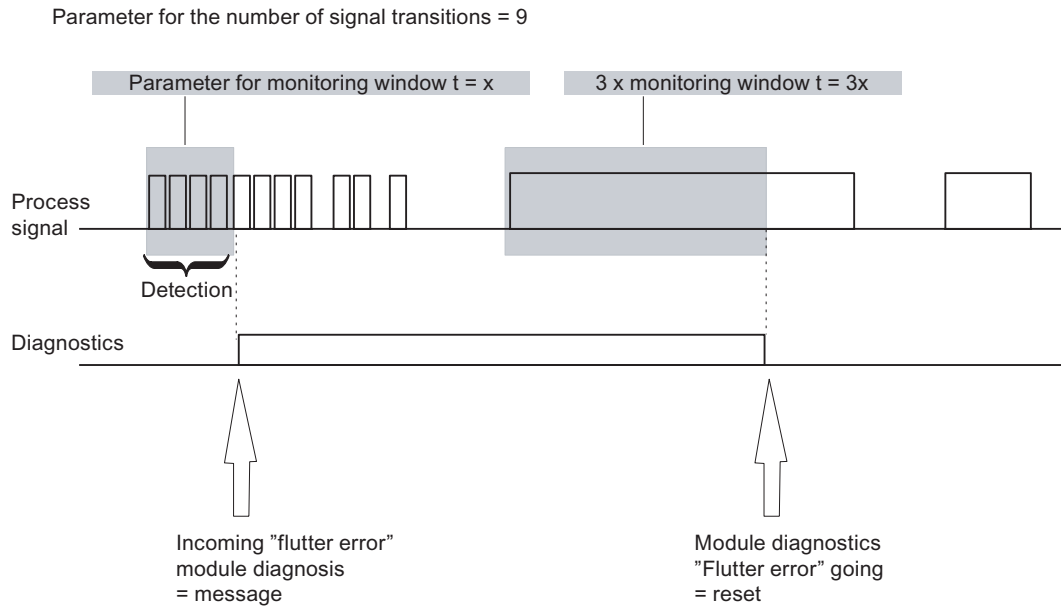

Figure 3-2 The principle of chatter monitoring

### 3.3 2DI 24 VDC ST digital electronic module (6ES7131-4BB01-0AA0)

#### Properties

- Digital electronic module with two inputs
- Nominal input voltage 24 VDC
- Suitable for switches and proximity switches (BEROs)

#### General terminal assignment

---

##### Note

Terminals 4, 8, A4, A8, A3 and A7 are only available at specified terminal modules.

---

Terminal assignment for the 2DI 24 VDC ST (6ES7131-4BB01-0AA0)				
Terminal	Assignment	Terminal	Assignment	Notes
1	DI <sub>0</sub>	5	DI <sub>1</sub>	<ul style="list-style-type: none"><li>• DI<sub>n</sub>: Input signal, channel n</li><li>• L+ Encoder power supply 24 VDC</li><li>• M: Chassis ground</li><li>• n.c.: Not connected (max. DC 30 V can be connected)</li><li>• AUX1: Protective-conductor terminal or potential bus (freely usable up to 230 VAC)</li></ul>
2	L+	6	L+	
3	M	7	M	
4	n.c.	8	n.c.	
A4	AUX1	A8	AUX1	
A3	AUX1	A7	AUX1	

Usable terminal modules

Usable terminal modules for the 2DI 24 VDC ST (6ES7131-4BB01-0AA0)				
TM-E15C26-A1 (6ES7193-4CA50-0AA0)	TM-E15C24-A1 (6ES7193-4CA30-0AA0)	TM-E15C24-01 (6ES7193-4CB30-0AA0)	TM-E15C23-01 (6ES7193-4CB10-0AA0)	← Spring terminal
TM-E15S26-A1 (6ES7193-4CA40-0AA0)	TM-E15S24-A1 (6ES7193-4CA20-0AA0)	TM-E15S24-01 (6ES7193-4CB20-0AA0)	TM-E15S23-01 (6ES7193-4CB00-0AA0)	← Screw terminal
TM-E15N26-A1 (6ES7193-4CA80-0AA0)	TM-E15N24-A1 (6ES7193-4CA70-0AA0)	TM-E15N24-01 (6ES7193-4CB70-0AA0)	TM-E15N23-01 (6ES7193-4CB60-0AA0)	← Fast Connect
				<p>Wiring examples</p> <p>* with a 4-wire connection must be connected to AUX1-terminal (A3, A4, A7, A8); AUX1 must be connected to PE via PM-E</p>

Block diagram

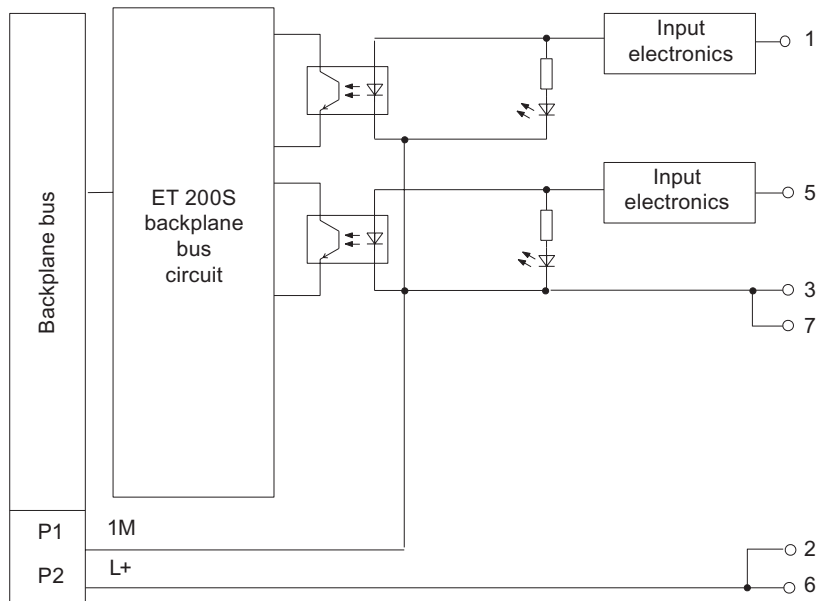

Figure 3-3 Block diagram of the 2DI 24 VDC Standard

2DI 24 VDC ST Technical Specifications (6ES7131-4BB01-0AA0).

Dimensions and Weight	
Dimensions W × H × D (mm) (the total dimensions depend on the selected terminal module)	15 × 81 × 52
Weight	Approx. 35 g
Data for specific modules	
Supports isochronous operation	no
Number of inputs	2
Cable length	
• Unshielded	max. 600 m
• Shielded	max. 1000 m
Parameter length	1 byte
Voltages, currents, potentials	
Rated supply voltage (from the power module)	24 VDC
• Reverse polarity protection	Yes
Galvanic isolation	
• Between the channels	no
• Between the channels and backplane bus	Yes
Permissible potential difference	
• Between the different circuits	75 VDC / 60 VAC
Insulation test voltage	500 VDC

Current consumption	
• From supply voltage	Dependent on the sensor
Power dissipation of the module	Typically 0.4 W
<b>Status, interrupts, diagnostics</b>	
Status display	Green LED per channel
Diagnostics function	no
<b>Sensor supply output</b>	
Output voltage	
• With load	min. L+ (-0.5 V)
Output current	
• Rated value	500 mA
• Permitted range	0 to 500 mA
<b>Data for selecting a sensor</b>	
Input voltage	
• Rated value	24 VDC
• For signal "1"	15 V to 30 V
• For signal "0"	-30 V to 5 V
Input current	
• At signal "1"	typ. 7 mA (for 24 V)
Input delay	
• at "0" to "1"	typ. 3 ms (2.0 to 4.5 ms)
• At "1" to "0"	typ. 3 ms (2.0 to 4.5 ms)
Input characteristic curve	according to IEC 61131, type 1
Connection of two-wire BEROs	supported
• Permitted bias current	max. 1.5 mA

### 3.4 4DI 24 VDC Standard digital electronic module (6ES7131-4BD01-0AA0)

#### Properties

- Digital electronics module with four inputs
- Nominal input voltage 24 VDC
- Suitable for switches and proximity switches (BEROs)

#### General terminal assignment

---

**Note**

Terminals 4, 8, A4, A8, A3 and A7 are only available at specified terminal modules.

---

Terminal assignment for the 4DI 24 VDC Standard (6ES7131-4BD01-0AA0).				
Terminal	Assignment	Terminal	Assignment	Notes
1	DI <sub>0</sub>	5	DI <sub>1</sub>	<ul style="list-style-type: none"><li>• DI<sub>n</sub>: Input signal, channel n</li><li>• L+: Encoder power supply 24 VDC</li><li>• AUX1: Protective-conductor terminal or potential bus (freely usable up to 230 VAC)</li></ul>
2	DI <sub>2</sub>	6	DI <sub>3</sub>	
3	L+	7	L+	
4	L+	8	L+	
A4	AUX1	A8	AUX1	
A3	AUX1	A7	AUX1	



Usable terminal modules

Usable terminal modules for the 4DI 24 VDC Standard (6ES7131-4BD01-0AA0).				
TM-E15C26-A1 (6ES7193-4CA50-0AA0)	TM-E15C24-A1 (6ES7193-4CA30-0AA0)	TM-E15C24-01 (6ES7193-4CB30-0AA0)	TM-E15C23-01 (6ES7193-4CB10-0AA0)	← Spring terminal
TM-E15S26-A1 (6ES7193-4CA40-0AA0)	TM-E15S24-A1 (6ES7193-4CA20-0AA0)	TM-E15S24-01 (6ES7193-4CB20-0AA0)	TM-E15S23-01 (6ES7193-4CB00-0AA0)	← Screw terminal
TM-E15N26-A1 (6ES7193-4CA80-0AA0)	TM-E15N24-A1 (6ES7193-4CA70-0AA0)	TM-E15N24-01 (6ES7193-4CB70-0AA0)	TM-E15N23-01 (6ES7193-4CB60-0AA0)	← Fast Connect
<p style="text-align: center;">Wiring examples</p> <div style="display: flex; justify-content: space-around;"> <div style="text-align: center;"> <p>2-wire</p> </div> <div style="text-align: center;"> <p>3-wire</p> </div> </div> <p>* connect to TM-E15x23-01 at terminal 3 or 7</p>				

Block diagram

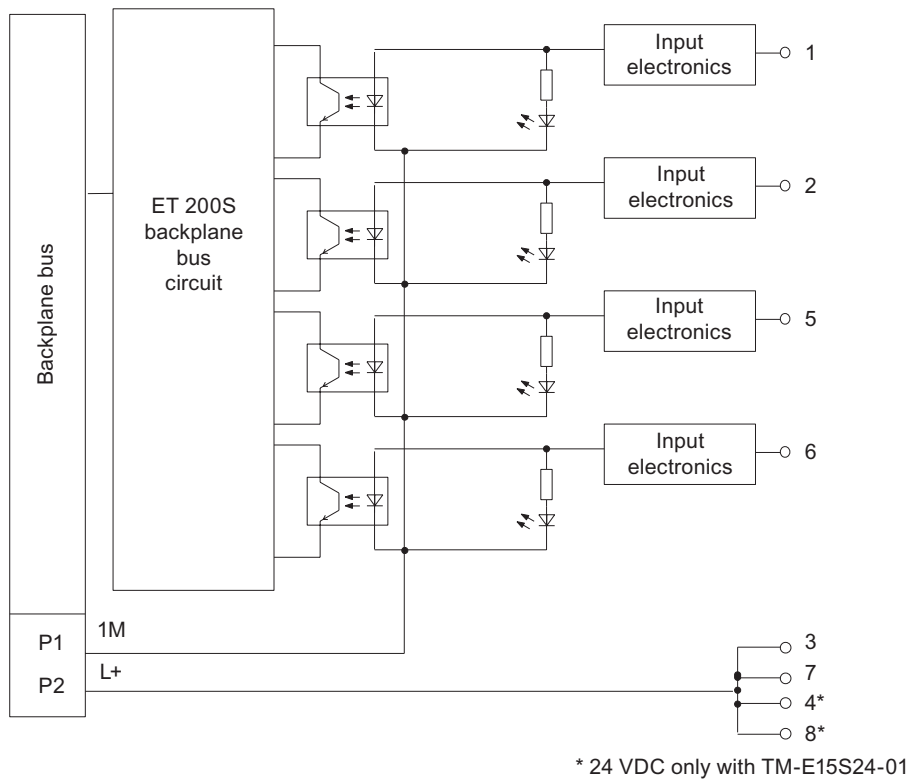

Figure 3-4 Block diagram of the 4DI 24 VDC Standard

4DI 24 VDC Standard Technical Specifications (6ES7131-4BD01-0AA0).

Dimensions and Weight	
Dimensions W × H × D (mm) (the total dimensions depend on the selected terminal module)	15 × 81 × 52
Weight	Approx. 35 g
Data for specific modules	
Supports isochronous operation	no
Number of inputs	4
Cable length	
• Unshielded	max. 600 m
• Shielded	max. 1000 m
Parameter length	1 byte
Voltages, currents, potentials	
Rated supply voltage (from the power module)	24 VDC
• Reverse polarity protection	Yes
Galvanic isolation	
• Between the channels	no
• Between the channels and backplane bus	Yes

Permissible potential difference	
• Between the different circuits	75 VDC / 60 VAC
Insulation test voltage	500 VDC
Current consumption	
• From supply voltage	Dependent on the sensor
Power dissipation of the module	Typically 0.7 W
<b>Status, interrupts, diagnostics</b>	
Status display	Green LED per channel
Diagnostics function	no
<b>Sensor supply output</b>	
Output voltage	
• With load	min. L+ (-0.5 V)
Output current	
• Rated value	500 mA
• Permitted range	0 to 500 mA
<b>Data for selecting a sensor</b>	
Input voltage	
• Rated value	24 VDC
• For signal "1"	15 V to 30 V
• For signal "0"	-30 V to 5 V
Input current	
• At signal "1"	typ. 7 mA (for 24 V)
Input delay	
• At "0" to "1"	typ. 3 ms (2.0 to 4.5 ms)
• At "1" to "0"	typ. 3 ms (2.0 to 4.5 ms)
Input characteristic curve	according to IEC 61131, type 1
Connection of two-wire BEROs	supported
• Permitted bias current	max. 1.5 mA

### 3.5 4DI 24 VDC/SRC Standard digital electronic module (6ES7131-4BD51-0AA0)

#### Properties

- Digital electronics module with four inputs
- Source input
- Nominal input voltage 24 VDC
- Suitable for switches and proximity switches (BEROs)

General terminal assignment

Note

Terminals 4, 8, A4, A8, A3 and A7 are only available at specified terminal modules.

Terminal assignment for the 4DI 24 VDC/SRC Standard (6ES7131-4BD51-0AA0).				
Terminal	Assignment	Terminal	Assignment	Notes
1	DI <sub>0</sub>	5	DI <sub>1</sub>	<ul style="list-style-type: none"> <li>DI<sub>n</sub>: Input signal, channel n</li> <li>M: Chassis ground</li> <li>AUX1: Protective-conductor terminal or potential bus (freely usable up to 230 VAC)</li> </ul>
2	DI <sub>2</sub>	6	DI <sub>3</sub>	
3	M	7	M	
4	M	8	M	
A4	AUX1	A8	AUX1	
A3	AUX1	A7	AUX1	

Usable terminal modules

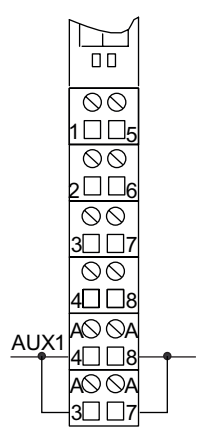
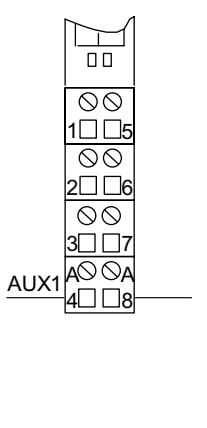
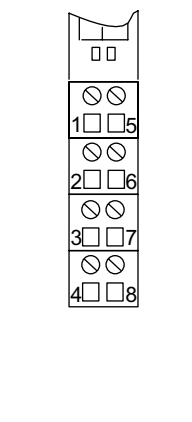
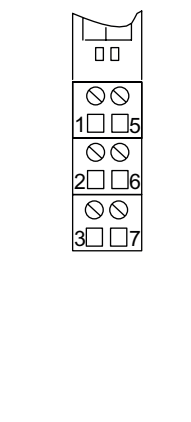
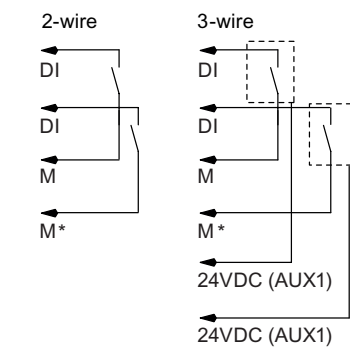
Usable terminal modules for the 4DI 24 VDC/SRC Standard (6ES7131-4BD51-0AA0).				
TM-E15C26-A1 (6ES7193-4CA50-0AA0)	TM-E15C24-A1 (6ES7193-4CA30-0AA0)	TM-E15C24-01 (6ES7193-4CB30-0AA0)	TM-E15C23-01 (6ES7193-4CB10-0AA0)	← Spring terminal
TM-E15S26-A1 (6ES7193-4CA40-0AA0)	TM-E15S24-A1 (6ES7193-4CA20-0AA0)	TM-E15S24-01 (6ES7193-4CB20-0AA0)	TM-E15S23-01 (6ES7193-4CB00-0AA0)	← Screw terminal
TM-E15N26-A1 (6ES7193-4CA80-0AA0)	TM-E15N24-A1 (6ES7193-4CA70-0AA0)	TM-E15N24-01 (6ES7193-4CB70-0AA0)	TM-E15N23-01 (6ES7193-4CB60-0AA0)	← Fast Connect
				<p>Wiring examples</p>  <p>* connect to TM-E15x23-01 at terminal 3 or 7</p>

Block diagram

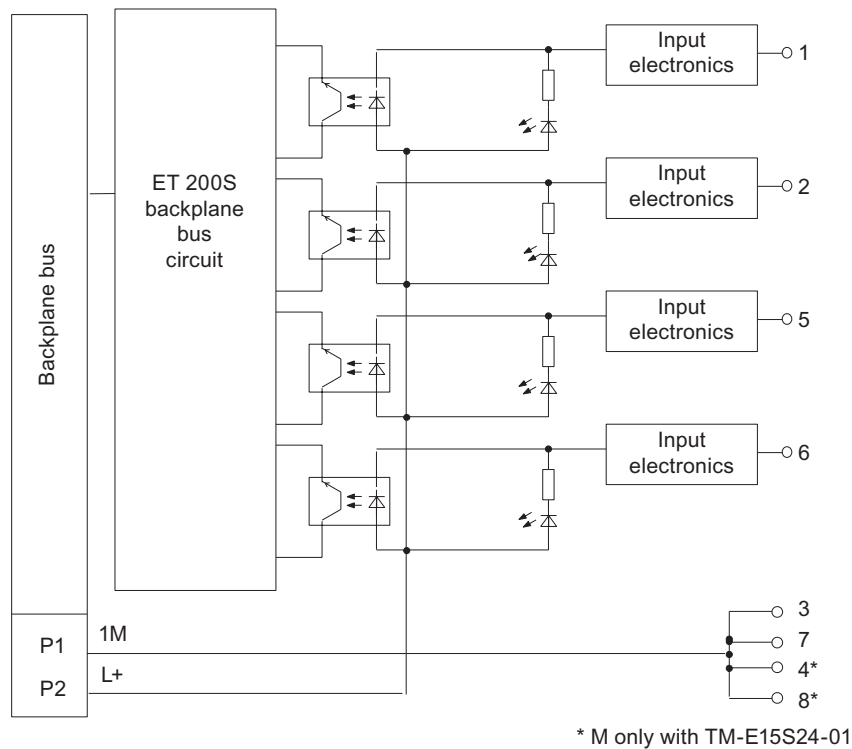

Figure 3-5 Block diagram of the 4DI 24 VDC/SRC Standard

4DI 24 VDC/SRC Standard Technical Specifications (6ES7131-4BD51-0AA0).

Dimensions and Weight	
Dimensions W × H × D (mm) (the total dimensions depend on the selected terminal module)	15 × 81 × 52
Weight	Approx. 35 g
Data for specific modules	
Supports isochronous operation	no
Number of inputs	4
Cable length	
• Unshielded	max. 600 m
• Shielded	max. 1000 m
Parameter length	1 byte
Voltages, currents, potentials	
Rated supply voltage (from the power module)	24 VDC
• Reverse polarity protection	Yes

Galvanic isolation	
• Between the channels	no
• Between the channels and backplane bus	Yes
Permissible potential difference	
• Between the different circuits	75 VDC / 60 VAC
Insulation test voltage	500 VDC
Current consumption	
• From supply voltage	Dependent on the sensor
Power dissipation of the module	Typically 0.7 W
<b>Status, interrupts, diagnostics</b>	
Status display	Green LED per channel
Diagnostics function	no
<b>Sensor supply output</b>	
Output voltage	
• With load	max. M +0.5 V
Output current	
• Rated value	500 mA
• Permitted range	0 to 500 mA
<b>Data for selecting a sensor</b>	
Input voltage	
• Rated value	24 VDC
• For signal "1"	-15 to -30 V <sup>1</sup>
• For signal "0"	30 to -5 V <sup>1</sup>
Input current	
• At signal "1"	typ. 7 mA (for 24 V)
Input delay	
• At "0" to "1"	typ. 3 ms (2.0 to 4.5 ms)
• At "1" to "0"	typ. 3 ms (2.0 to 4.5 ms)
Input characteristic curve	according to IEC 61131, type 1
Connection of two-wire BEROs	supported
• Permitted bias current	max. 1.5 mA
<sup>1</sup> Reference potential is L+	

### 3.6 2DI 24 VDC High Feature digital electronic module (6ES7131-4BB01-0AB0)

#### Properties

- Digital electronic module with two inputs
- Nominal input voltage 24 VDC
- Diagnostics: Short circuit
- Short-circuit protection
- Suitable for switches and proximity switches (BEROs)
- Supports isochronous operation

#### General terminal assignment

---

##### Note

Terminals 4, 8, A4, A8, A3 and A7 are only available at specified terminal modules.

---

Terminal assignment of the 2DI 24 VDC High Feature (6ES7131-4BB01-0AB0)				
Terminal	Assignment	Terminal	Assignment	Notes
1	DI <sub>0</sub>	5	DI <sub>1</sub>	<ul style="list-style-type: none"> <li>• DI<sub>n</sub>: Input signal, channel n</li> <li>• L+: Encoder power supply 24 VDC</li> <li>• M: Chassis ground</li> <li>• n.c.: Not connected (max. DC 30 V can be connected)</li> <li>• AUX1: Protective-conductor terminal or potential bus (freely usable up to 230 VAC)</li> </ul>
2	L+	6	L+	
3	M	7	M	
4	n.c.	8	n.c.	
A4	AUX1	A8	AUX1	
A3	AUX1	A7	AUX1	

Usable terminal modules

Usable terminal module of the 2DI 24 VDC High Feature (6ES7131-4BB01-0AB0)				
TM-E15C26-A1 (6ES7193-4CA50-0AA0)	TM-E15C24-A1 (6ES7193-4CA30-0AA0)	TM-E15C24-01 (6ES7193-4CB30-0AA0)	TM-E15C23-01 (6ES7193-4CB10-0AA0)	← Spring terminal
TM-E15S26-A1 (6ES7193-4CA40-0AA0)	TM-E15S24-A1 (6ES7193-4CA20-0AA0)	TM-E15S24-01 (6ES7193-4CB20-0AA0)	TM-E15S23-01 (6ES7193-4CB00-0AA0)	← Screw terminal
TM-E15N26-A1 (6ES7193-4CA80-0AA0)	TM-E15N24-A1 (6ES7193-4CA70-0AA0)	TM-E15N24-01 (6ES7193-4CB70-0AA0)	TM-E15N23-01 (6ES7193-4CB60-0AA0)	← Fast Connect
<p style="text-align: center;">Wiring examples</p> <p>2-wire: DI, L+</p> <p>3-wire: DI, L+, M</p> <p>4-wire: DI, L+, M, PE (AUX1)</p> <p>* with a 4-wire connection must be connected to AUX1-terminal (A3, A4, A7, A8); AUX1 must be connected to PE via PM-E</p>				



Block diagram

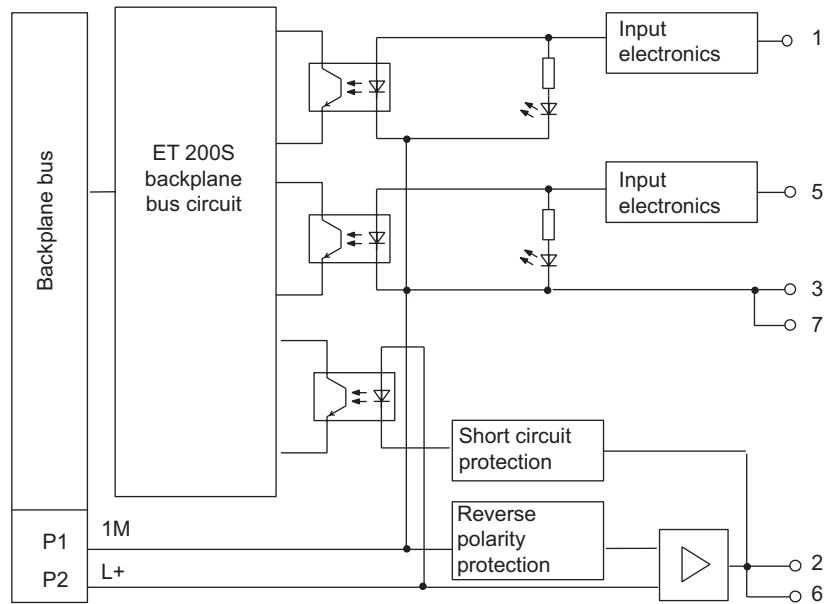

Figure 3-6 Block diagram of the 2DI 24 VDC High Feature

Technical Specifications 2DI 24 VDC High Feature (6ES7131-4BB01-0AB0)

Dimensions and Weight	
Dimensions W × H × D (mm) (the total dimensions depend on the selected terminal module)	15 × 81 × 52
Weight	Approx. 35 g
Data for specific modules	
Supports isochronous operation	Yes
Number of inputs	2
Cable length	
• Unshielded	max. 600 m
• Shielded	max. 1000 m
Parameter length	3 bytes
Voltages, currents, potentials	
Rated supply voltage (from the power module)	24 VDC
• Reverse polarity protection	Yes
Galvanic isolation	
• Between the channels	no
• Between the channels and backplane bus	Yes
Permissible potential difference	
• Between the different circuits	75 VDC / 60 VAC
Insulation test voltage	500 VDC

Current consumption	
• From supply voltage	Dependent on the sensor
Power dissipation of the module	Typically 0.4 W
<b>Status, interrupts, diagnostics</b>	
Status display	Green LED per channel
Interrupts	
• Hardware interrupt	Parameters can be assigned
Diagnostics function	
• General fault	Red "SF" LED
• Diagnostic information can be displayed	Yes
<b>Sensor supply output</b>	
Output voltage	
• With load	min. L+ (-0.5 V)
Output current	
• Rated value	500 mA
• Permitted range	0 to 500 mA
Short-circuit protection	Yes, electronic <sup>1</sup>
<b>Data for selecting a sensor</b>	
Input voltage	
• Rated value	24 VDC
• For signal "1"	11 V to 30 V
• For signal "0"	-30 V to 5 V
Input current	
• At signal "1"	Typ. 8 mA
Input delay (parameters can be assigned)	
• At "0" to "1"	0.1 ms (0.05 to 0.15 ms) 0.5 ms (0.4 to 0.6 ms) 3 ms (2.7 to 3.3 ms) 15 ms (14.85 to 15.15 ms)
• At "1" to "0"	0.1 ms (0.05 to 0.15 ms) 0.5 ms (0.4 to 0.6 ms) 3 ms (2.7 to 3.3 ms) 15 ms (14.85 to 15.15 ms)
Input characteristic curve	according to IEC 61131, type 1
Connection of two-wire BEROs	supported
• Permitted bias current	max. 1.5 mA
<sup>1</sup> Per module	

### 3.7 4DI 24 VDC High Feature digital electronic module (6ES7131-4BD01-0AB0)

#### Properties

- Digital electronics module with four inputs
- Nominal input voltage 24 VDC
- Diagnostics: Short circuit
- Short circuit protection
- Suitable for switches and proximity switches (BEROs)
- Supports isochronous operation

#### General terminal assignment

---

##### Note

Terminals 4, 8, A4, A8, A3 and A7 are only available at specified terminal modules.

---

Terminal assignment of the 4DI 24 VDC High Feature (6ES7131-4BD01-0AB0)				
Terminal	Assignment	Terminal	Assignment	Notes
1	DI <sub>0</sub>	5	DI <sub>1</sub>	<ul style="list-style-type: none"> <li>• DI<sub>n</sub>: Input signal, channel n</li> <li>• L+: Encoder power supply 24 VDC</li> <li>• AUX1: Protective-conductor terminal or potential bus (freely usable up to 230 VAC)</li> </ul>
2	DI <sub>2</sub>	6	DI <sub>3</sub>	
3	L+	7	L+	
4	L+	8	L+	
A4	AUX1	A8	AUX1	
A3	AUX1	A7	AUX1	

Usable terminal modules

Usable terminal modules of the 4DI 24 VDC High Feature (6ES7131-4BD01-0AB0)				
TM-E15C26-A1 (6ES7193-4CA50-0AA0)	TM-E15C24-A1 (6ES7193-4CA30-0AA0)	TM-E15C24-01 (6ES7193-4CB30-0AA0)	TM-E15C23-01 (6ES7193-4CB10-0AA0)	← Spring terminal
TM-E15S26-A1 (6ES7193-4CA40-0AA0)	TM-E15S24-A1 (6ES7193-4CA20-0AA0)	TM-E15S24-01 (6ES7193-4CB20-0AA0)	TM-E15S23-01 (6ES7193-4CB00-0AA0)	← Screw terminal
TM-E15N26-A1 (6ES7193-4CA80-0AA0)	TM-E15N24-A1 (6ES7193-4CA70-0AA0)	TM-E15N24-01 (6ES7193-4CB70-0AA0)	TM-E15N23-01 (6ES7193-4CB60-0AA0)	← Fast Connect
<p style="text-align: center;">Wiring examples</p> <p>2-wire: DI, L+, L+*</p> <p>3-wire: DI, L+, L+*, M (AUX1)</p> <p>* connect to TM-E15x23-01 at terminal 3 or 7</p>				

Block diagram

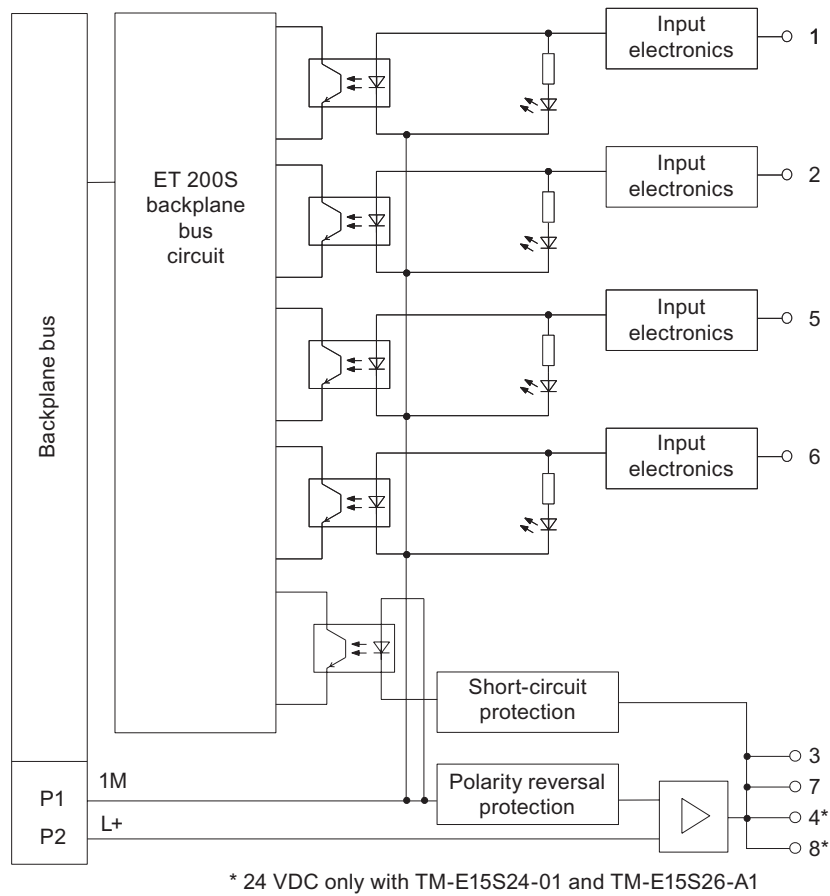

Figure 3-7 Block diagram of the 4DI 24 VDC High Feature

4DI 24 VDC High Feature Technical Specifications (6ES7131-4BD01-0AB0)

Dimensions and Weight	
Dimensions W × H × D (mm) (the total dimensions depend on the selected terminal module)	15 × 81 × 52
Weight	Approx. 35 g
Data for specific modules	
Supports isochronous operation	Yes
Number of inputs	4
Cable length	
• Unshielded	max. 600 m
• Shielded	max. 1000 m
Parameter length	3 bytes

<b>Voltages, currents, potentials</b>	
Rated supply voltage (from the power module)	24 VDC
• Reverse polarity protection	Yes
Galvanic isolation	
• Between the channels	no
• Between the channels and backplane bus	Yes
Permissible potential difference	
• Between the different circuits	75 VDC / 60 VAC
Insulation test voltage	500 VDC
Current consumption	
• From supply voltage	Dependent on the sensor
Power dissipation of the module	Typically 0.7 W
<b>Status, interrupts, diagnostics</b>	
Status display	Green LED per channel
Interrupts	
• Hardware interrupt	Parameters can be assigned
Diagnostics function	
• General fault	Red "SF" LED
• Diagnostic information can be displayed	Yes
<b>Sensor supply output</b>	
Output voltage	
• With load	min. L+ (-0.5 V)
Output current	
• Rated value	500 mA
• Permitted range	0 to 500 mA
Short-circuit protection	Yes, electronic <sup>1</sup>
<b>Data for selecting a sensor</b>	
Input voltage	
• Rated value	24 VDC
• For signal "1"	11 V to 30 V
• For signal "0"	-30 V to 5 V
Input current	
• At signal "1"	Typ. 8 mA
Input delay (parameters can be assigned)	
• At "0" to "1"	0.1 ms (0.05 to 0.15 ms) 0.5 ms (0.4 to 0.6 ms) 3 ms (2.7 to 3.3 ms) 15 ms (14.85 to 15.15 ms)
• At "1" to "0"	0.1 ms (0.05 to 0.15 ms) 0.5 ms (0.4 to 0.6 ms) 3 ms (2.7 to 3.3 ms) 15 ms (14.85 to 15.15 ms)
Input characteristic curve	according to IEC 61131, type 1
Connection of two-wire BEROs	supported
• Permitted bias current	max. 1.5 mA
<sup>1</sup> Per module	

### 3.8 4DI 24 VUC to 48 VUC High Feature digital electronic module (6ES7131-4CD00-0AB0)

#### Properties

- Digital electronics module with four inputs
- Rated input voltage 24 VAC/VDC to 48 VAC/VDC
- Diagnostics: Wire break
- Diagnostics: Fuse blown
- Diagnostics: No load voltage
- Suitable for switches and proximity switches (BEROs)
- Supports isochronous operation

#### General terminal assignment

---

##### Note

Terminals 4, 8, A4, A8, A3 and A7 are only available at specified terminal modules.

---

Terminal assignment of the 4DI 24 VUC to 48 VUC High Feature (6ES7131-4CD00-0AB0)				
Terminal	Assignment	Terminal	Assignment	Notes
1	DI <sub>0</sub>	5	DI <sub>1</sub>	<ul style="list-style-type: none"> <li>• DI<sub>n</sub>: Input signal, channel n</li> <li>• L+: Sensor power supply 24 VAC/VDC to 48 VAC/VDC</li> <li>• AUX1: Protective-conductor terminal or potential bus (freely usable up to 230 VAC)</li> </ul>
2	DI <sub>2</sub>	6	DI <sub>3</sub>	
3	L+	7	L+	
4	L+	8	L+	
A4	AUX1	A8	AUX1	
A3	AUX1	A7	AUX1	

Usable terminal modules

Usable terminal modules of the 4DI 24 VUC to 48 VUC High Feature (6ES7131-4CD00-0AB0)				
TM-E15C26-A1 (6ES7193-4CA50-0AA0)	TM-E15C24-A1 (6ES7193-4CA30-0AA0)	TM-E15C24-01 (6ES7193-4CB30-0AA0)	TM-E15C23-01 (6ES7193-4CB10-0AA0)	← Spring terminal
TM-E15S26-A1 (6ES7193-4CA40-0AA0)	TM-E15S24-A1 (6ES7193-4CA20-0AA0)	TM-E15S24-01 (6ES7193-4CB20-0AA0)	TM-E15S23-01 (6ES7193-4CB00-0AA0)	← Screw terminal
TM-E15N26-A1 (6ES7193-4CA80-0AA0)	TM-E15N24-A1 (6ES7193-4CA70-0AA0)	TM-E15N24-01 (6ES7193-4CB70-0AA0)	TM-E15N23-01 (6ES7193-4CB60-0AA0)	← Fast Connect
<p style="text-align: center;">Wiring examples</p> <p>2-wire: DI, L+, L+*</p> <p>3-wire: DI, L+, L+*, M (AUX1), M (AUX1)</p> <p>* connect to TM-E15x23-01 at terminal 3 or 7</p>				



Block diagram

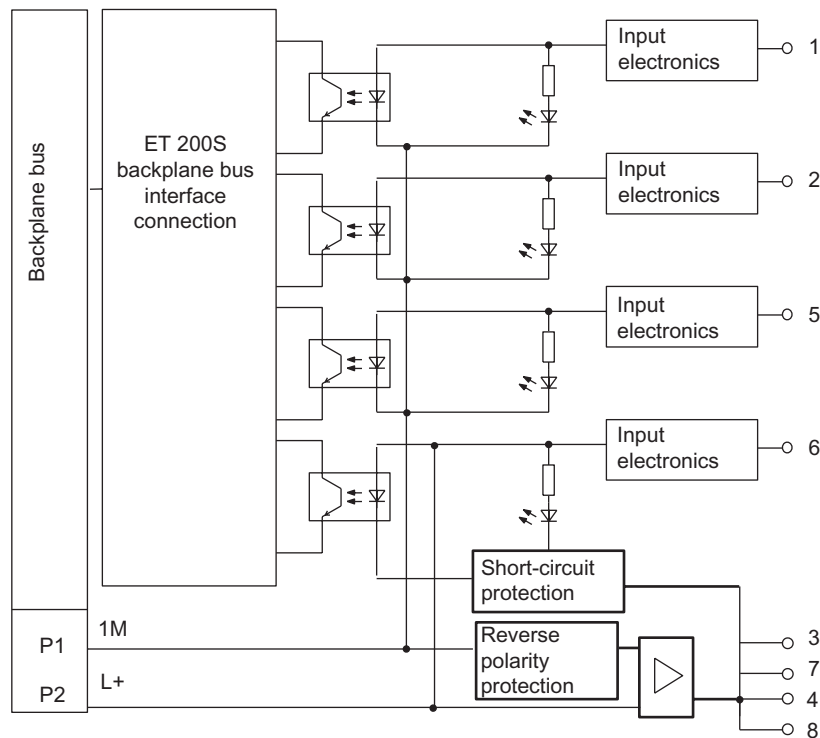

Figure 3-8 Block diagram of the 4DI 24 to 48 VUC High Feature

4DI VUC 24 to 48 VUC High Feature Technical Specifications (6ES7131-4CD00-0AB0)

Dimensions and Weight	
Dimensions W × H × D (the total dimensions depend on the selected terminal module)	15 × 81 × 52 (mm)
Weight	Approx. 35 g
Data for specific modules	
Supports isochronous operation	Yes
Number of inputs	4
Cable length	
• Unshielded	max. 600 m
• Shielded	max. 1000 m
Parameter length	3 bytes
Voltages, currents, potentials	
Rated supply voltage (from the power module)	24 VAC/VDC to 48 VAC/VDC
• Horizontal installation up to 60° C	
• Vertical installation up to 40° C	
• Reverse polarity protection	AC or DC automatically

Galvanic isolation	
• Between the channels	no
• Between channels and backplane bus	Yes
Permissible potential difference	
• Between the different circuits	75 VDC, 60 VAC
Insulation test voltage	2500 VDC
Current consumption	
• From the power supply L+	Dependent on the sensor
• From the backplane bus	max. 10 mA
Power dissipation of the module	Typically 0.7 W
<b>Status, interrupts, diagnostics</b>	
Status display	Green LEDs per channel
Diagnostics function	Parameters can be assigned
• Group error display	Red LEDs (SF)
<b>Sensor power supply outputs</b>	
Output voltage	
• With load	min. L+ (-0.5 V)
Output current	
• Rated value	500 mA
• Permitted range	0 to 500 mA
Short-circuit protection	Yes (per module)
<b>Data for selecting a sensor</b>	
Input voltage	
• Rated value	24 to 48 VUC
• For signal "1"	-15 VDC to -57.6 VDC 15 VDC to 57.6 VDC 15 VAC to 48 VAC
• For signal "0"	-6 VDC to 6 VDC 0 VAC to 5 VAC
• Frequency range	47 Hz to 63 Hz
Input current	
• At signal "1"	From 4 mA to 10 mA
Input delay	
• At "0" to "1"	max. 15 ms
• At "1" to "0"	max. 15 ms
Input characteristic curve <sup>1</sup>	
Connection of two-wire BEROs	supported
• Permitted bias current	max. 0.5 to 2 mA <sup>2</sup>
<b>Sensor switching</b>	
Resistance circuit of the sensor for wire break monitoring	
• Nominal voltage 24 V (15 V to 35 V)	18 kΩ
• Nominal voltage 48 V (30 V to 60 V)	39 kΩ
<sup>1</sup> IEC 61131 does not provide technical specifications for UC modules. However, the values have been adjusted to IEC 61131 as closely as possible. <sup>2</sup> Minimum load current is required in the case of wire-break monitoring.	

### 3.9 4DI NAMUR digital electronic module (6ES7131-4RD01-0AB0)

#### Properties

- Digital electronics module with four inputs
- Encoder power supply 8.2 VDC
- Suitable for NAMUR sensors and both closed and open mechanical contacts

#### General terminal assignment

##### Note

Terminals 4, 8, A4, A8, A3 and A7 are only available at specified terminal modules.

Terminal assignment of the 4DI NAMUR (6ES7131-4RD01-0AB0)				
Terminal	Assignment	Terminal	Assignment	Notes
1	DI <sub>0</sub>	5	DI <sub>1</sub>	<ul style="list-style-type: none"> <li>• DI<sub>n</sub>: Input signal, channel n</li> <li>• V<sub>S</sub>: Encoder power supply 8.2 VDC</li> <li>• AUX1: Protective-conductor terminal or potential bus (freely usable up to 230 VAC)</li> </ul>
2	DI <sub>2</sub>	6	DI <sub>3</sub>	
3	V <sub>S</sub>	7	V <sub>S</sub>	
4	V <sub>S</sub>	8	V <sub>S</sub>	
A4	AUX1	A8	AUX1	
A3	AUX1	A7	AUX1	

Usable terminal modules for connection of NAMUR sensors and sensors to IEC 60947-5-6

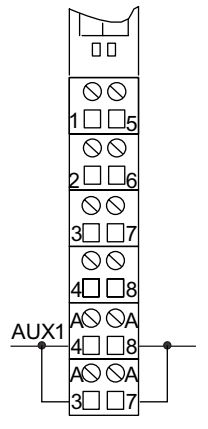
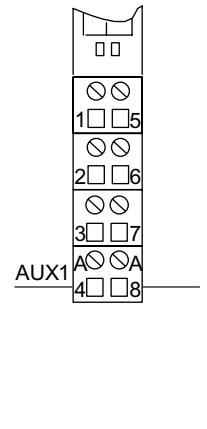
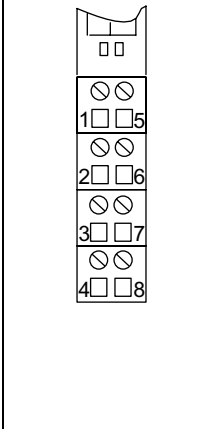
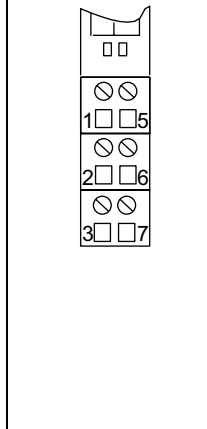
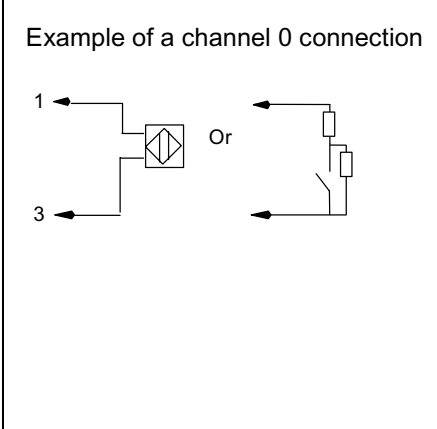
Usable terminal modules for the 4DI NAMUR (6ES7131-4RD01-0AB0)				
TM-E15C26-A1 (6ES7193-4CA50-0AA0)	TM-E15C24-A1 (6ES7193-4CA30-0AA0)	TM-E15C24-01 (6ES7193-4CB30-0AA0)	TM-E15C23-01 (6ES7193-4CB10-0AA0)	← Spring terminal
TM-E15S26-A1 (6ES7193-4CA40-0AA0)	TM-E15S24-A1 (6ES7193-4CA20-0AA0)	TM-E15S24-01 (6ES7193-4CB20-0AA0)	TM-E15S23-01 (6ES7193-4CB00-0AA0)	← Screw terminal
TM-E15N26-A1 (6ES7193-4CA80-0AA0)	TM-E15N24-A1 (6ES7193-4CA70-0AA0)	TM-E15N24-01 (6ES7193-4CB70-0AA0)	TM-E15N23-01 (6ES7193-4CB60-0AA0)	← Fast Connect
				<p>Example of a channel 0 connection</p> 

Usable terminal modules for connection of NAMUR changeover contacts and sensors to IEC 60947-5-6

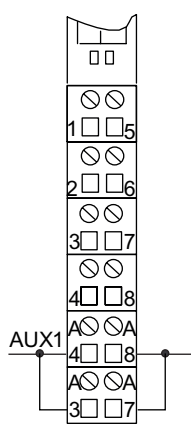
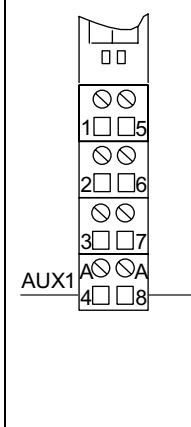
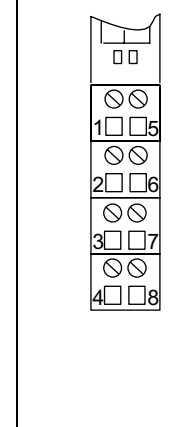
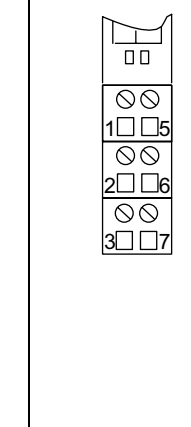
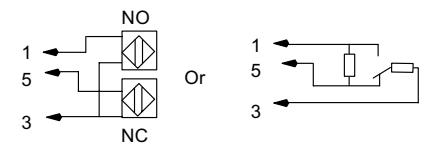
Usable terminal modules for the 4DI NAMUR (6ES7131-4RD01-0AB0)				
TM-E15C26-A1 (6ES7193-4CA50-0AA0)	TM-E15C24-A1 (6ES7193-4CA30-0AA0)	TM-E15C24-01 (6ES7193-4CB30-0AA0)	TM-E15C23-01 (6ES7193-4CB10-0AA0)	← Spring terminal
TM-E15S26-A1 (6ES7193-4CA40-0AA0)	TM-E15S24-A1 (6ES7193-4CA20-0AA0)	TM-E15S24-01 (6ES7193-4CB20-0AA0)	TM-E15S23-01 (6ES7193-4CB00-0AA0)	← Screw terminal
TM-E15N26-A1 (6ES7193-4CA80-0AA0)	TM-E15N24-A1 (6ES7193-4CA70-0AA0)	TM-E15N24-01 (6ES7193-4CB70-0AA0)	TM-E15N23-01 (6ES7193-4CB60-0AA0)	← Fast Connect
				<p>Example of a channel 0 and channel 1 connection</p> 

Usable terminal modules for connection of a single contact with 10 kΩ circuit (mechanical normally open contact)

Usable terminal modules for the 4DI NAMUR (6ES7131-4RD01-0AB0)				
TM-E15C26-A1 (6ES7193-4CA50-0AA0)	TM-E15C24-A1 (6ES7193-4CA30-0AA0)	TM-E15C24-01 (6ES7193-4CB30-0AA0)	TM-E15C23-01 (6ES7193-4CB10-0AA0)	← Spring terminal
TM-E15S26-A1 (6ES7193-4CA40-0AA0)	TM-E15S24-A1 (6ES7193-4CA20-0AA0)	TM-E15S24-01 (6ES7193-4CB20-0AA0)	TM-E15S23-01 (6ES7193-4CB00-0AA0)	← Screw terminal
TM-E15N26-A1 (6ES7193-4CA80-0AA0)	TM-E15N24-A1 (6ES7193-4CA70-0AA0)	TM-E15N24-01 (6ES7193-4CB70-0AA0)	TM-E15N23-01 (6ES7193-4CB60-0AA0)	← Fast Connect

**Usable terminal modules for connection of a single changeover contact with 10 kΩ circuit (mechanical changeover contact)**

Usable terminal modules for the 4DI NAMUR (6ES7131-4RD01-0AB0)				
TM-E15C26-A1 (6ES7193-4CA50-0AA0)	TM-E15C24-A1 (6ES7193-4CA30-0AA0)	TM-E15C24-01 (6ES7193-4CB30-0AA0)	TM-E15C23-01 (6ES7193-4CB10-0AA0)	← Spring terminal
TM-E15S26-A1 (6ES7193-4CA40-0AA0)	TM-E15S24-A1 (6ES7193-4CA20-0AA0)	TM-E15S24-01 (6ES7193-4CB20-0AA0)	TM-E15S23-01 (6ES7193-4CB00-0AA0)	← Screw terminal
TM-E15N26-A1 (6ES7193-4CA80-0AA0)	TM-E15N24-A1 (6ES7193-4CA70-0AA0)	TM-E15N24-01 (6ES7193-4CB70-0AA0)	TM-E15N23-01 (6ES7193-4CB60-0AA0)	← Fast Connect
				<p>Example of a channel 0 and channel 1 connection</p>

**Usable terminal modules for connection of a single contact, open (mechanical normally open contact with single contact)**

Usable terminal modules for the 4DI NAMUR (6ES7131-4RD01-0AB0)				
TM-E15C26-A1 (6ES7193-4CA50-0AA0)	TM-E15C24-A1 (6ES7193-4CA30-0AA0)	TM-E15C24-01 (6ES7193-4CB30-0AA0)	TM-E15C23-01 (6ES7193-4CB10-0AA0)	← Spring terminal
TM-E15S26-A1 (6ES7193-4CA40-0AA0)	TM-E15S24-A1 (6ES7193-4CA20-0AA0)	TM-E15S24-01 (6ES7193-4CB20-0AA0)	TM-E15S23-01 (6ES7193-4CB00-0AA0)	← Screw terminal
TM-E15N26-A1 (6ES7193-4CA80-0AA0)	TM-E15N24-A1 (6ES7193-4CA70-0AA0)	TM-E15N24-01 (6ES7193-4CB70-0AA0)	TM-E15N23-01 (6ES7193-4CB60-0AA0)	← Fast Connect



**Usable terminal modules for connection of a changeover contact, open (mechanical changeover contact)**

Usable terminal modules for the 4DI NAMUR (6ES7131-4RD01-0AB0)				
TM-E15C26-A1 (6ES7193-4CA50-0AA0)	TM-E15C24-A1 (6ES7193-4CA30-0AA0)	TM-E15C24-01 (6ES7193-4CB30-0AA0)	TM-E15C23-01 (6ES7193-4CB10-0AA0)	← Spring terminal
TM-E15S26-A1 (6ES7193-4CA40-0AA0)	TM-E15S24-A1 (6ES7193-4CA20-0AA0)	TM-E15S24-01 (6ES7193-4CB20-0AA0)	TM-E15S23-01 (6ES7193-4CB00-0AA0)	← Screw terminal
TM-E15N26-A1 (6ES7193-4CA80-0AA0)	TM-E15N24-A1 (6ES7193-4CA70-0AA0)	TM-E15N24-01 (6ES7193-4CB70-0AA0)	TM-E15N23-01 (6ES7193-4CB60-0AA0)	← Fast Connect
<p>Example of a channel 0 and channel 1 connection</p> <p>1 ←</p> <p>5 ←</p> <p>3 ←</p>				

Block diagram

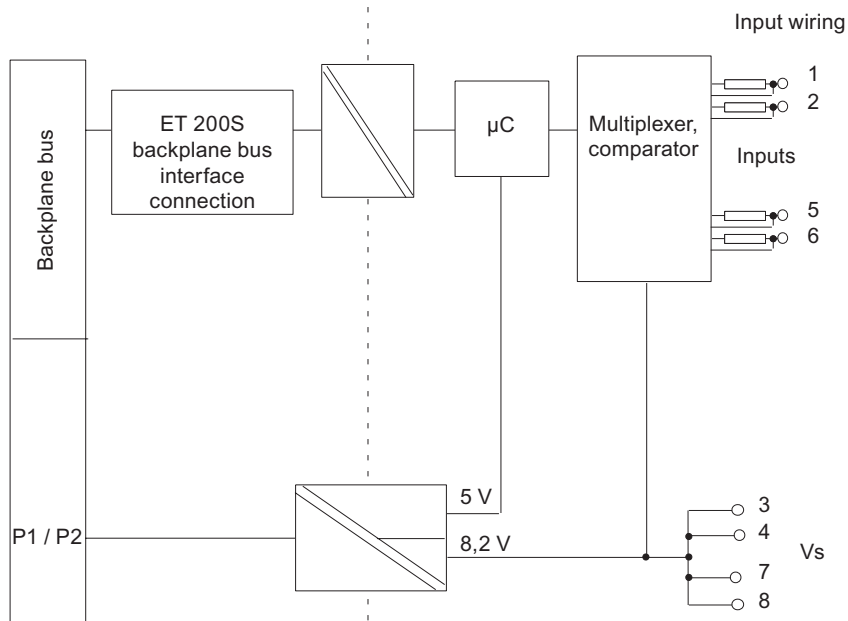

Figure 3-9 Block diagram of the 4DI NAMUR

4DI NAMUR Technical Specifications (6ES7131-4RD01-0AB0)

Dimensions and Weight	
Dimensions W × H × D (mm) (the total dimensions depend on the selected terminal module)	15 × 81 × 52
Weight	Approx. 35 g
Data for specific modules	
Supports isochronous operation	no
Number of inputs	4
Cable length	
• Shielded	max. 200 m
Voltages, currents, potentials	
Number of inputs that can be triggered simultaneously	4
• Horizontal mounting up to 60 °C	4
• All other mounting positions up to 40° C	4
Galvanic isolation	
• Between the channels	no
• Between channels and backplane bus	Yes
• Between channels and load voltage	Yes
• Between load voltage and backplane bus	Yes

Permissible potential difference	
• Between different circuits	75 VDC, 60 VAC
Insulation test voltage:	
• Channels against the backplane bus and load voltage	500 VDC
• Load voltage against the backplane bus	500 VDC
Current consumption	
• From load voltage L+	Dependent on the sensor
Power dissipation of the module	Typically 1.6 W
Parameter length	12 bytes
<b>Status, interrupts, diagnostics</b>	
Status display	Green LED per channel
Interrupts	
• Hardware interrupt	no
• Diagnostic interrupt	Yes, can be set
Diagnostics function	
• Group error display	Red "SF" LED supported
• Diagnostic information can be displayed	
Monitoring for	
• Short circuit	$I > 7 \text{ mA}^1$
• Wire break	$I > 0.35 \text{ mA}^1$
<b>Data for selecting a sensor</b>	
Input current for NAMUR sensors	to NAMUR or EN 50227
• At signal "1"	2.1 mA to 7 mA
• At signal "0"	0.35 mA to 1.2 mA
Input current for a closed contact	
• At signal "1"	2.1 mA to 7 mA
• For signal "0"	0.35 mA to 1.2 mA
Input current for an open contact	
• At signal "1"	Typ. 8 mA
• Permitted bias current	0.5 mA
Input delay	
• At "0" to "1"	max. 4.6 ms
• At "1" to "0"	max. 4.6 ms
Tolerated switchover time with changeover contacts	300 ms
Parallel connection of inputs	no
<b>Sensor power supply outputs</b>	
Number of outputs	1
Output voltage	
• With load	min. 8.2 V
Output current	
• Rated value	45 mA
Additional (redundant) supply	Not permitted
Short-circuit protection	Yes, electronic
<sup>1</sup> Only for NAMUR sensors and closed contacts.	

### Value status

The value status provides additional binary information on a digital input signal. The value status is entered in the process input image at the same time as the signal, and it provides information on the validity of the input signal. The value status is affected by:

- Wire break check/short circuit
- Chatter monitoring
- Pulse stretching
- Validity check of changeover contact sensor types

Meaning of the value status:

- "1": Input signal is valid
- "0": Input signal is invalid

### Assignment in the process input image

The data is transferred to the process image in two bytes (16 bits).

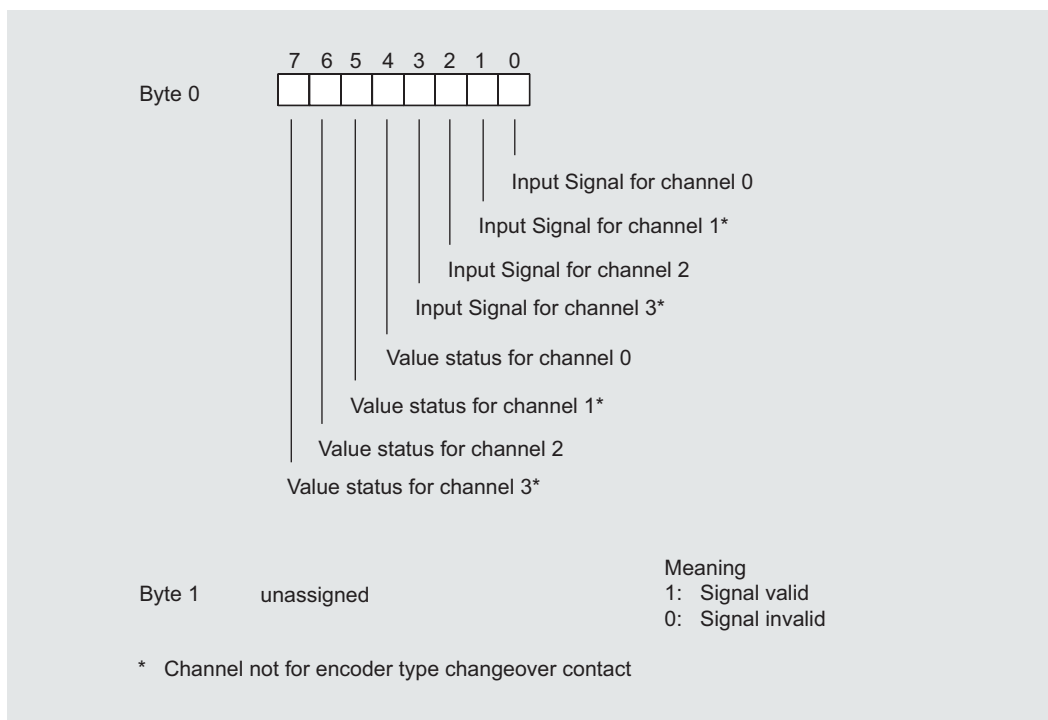

Figure 3-10 Assignment in the process input image for 4DI NAMUR

## Diagnosis for changeover contact sensor types

When a diagnosis is made for the changeover contact sensor type, the digital electronic module controls the switchover between two input channels. If there is no signal change in the normally closed contact after the set switchover time (see technical specifications), the module reports a diagnosis.

### Purpose of changeover contact diagnostics

You can use the diagnosis for the following:

- A diagnosis of the sensor
- To make absolutely sure that there has been a switchover between a normally open contact and normally closed contact

### Principle of changeover contact diagnostics

If the digital inputs of a channel group are configured as "changeover contacts", the module for this channel group carries out a diagnostics for the changeover contact type of sensor. The tolerated changeover time between the two channels is set to the fixed value of 300 ms.

If the validity check is negative, the following applies:

- The module identifies the value status of the normally open contact channel as "invalid".
- The module creates a diagnostic entry for the NO contact channel.
- The module triggers a diagnostic interrupt.

The digital input signal and the value status are only updated for the NO contact channel (channel 0 and 2). In the case of the NC contact channel (channel 1 and 3) the digital input signal is fixed at "zero" and the value status is "invalid" because this channel is only used for a validity check of the sensor.

Note the following points when carrying out a diagnosis for a changeover contact sensor type:

- If there is already an error on the normally open contact channel (a wire break, for example), the module no longer performs diagnostics for changeover contact errors. The diagnosis for changeover contact errors continues to be carried out on the second channel.
- You will find additional points to note in the following table:

Table 3-4 Diagnosis for changeover contacts

Changeover contact	A negative check means...	
Changeover contact as NAMUR	<ul style="list-style-type: none"> <li>• Short circuit or</li> <li>• Wire break</li> </ul>	Additionally: Changeover contact error or external fault (in the case of DP diagnosis)
Closed changeover contact	<ul style="list-style-type: none"> <li>• Defective sensor or short circuit</li> </ul> No distinction can be made here between a defective sensor and short circuit	
Open changeover contact	Caution: No distinction possible between <ul style="list-style-type: none"> <li>• Signal "0" and wire break</li> <li>• Signal "1" and short circuit</li> </ul>	

### 3.10 2DI 120 VAC Standard digital electronic module (6ES7131-4EB01-0AB0)

#### Properties

- Digital electronic module with two inputs
- Rated input voltage 120 VAC
- Suitable for switches

#### General terminal assignment

---

**Note**

Terminals 4, 8, A4, A8, A3 and A7 are only available at specified terminal modules.

---

Terminal assignment for 2DI 120 VAC Standard (6ES7131-4EB01-0AB0)				
Terminal	Assignment	Terminal	Assignment	Notes
1	DI <sub>0</sub>	5	DI <sub>1</sub>	<ul style="list-style-type: none"><li>• DI<sub>n</sub>: Input signal, channel n</li><li>• L1: Sensor power supply 120 VAC</li><li>• N: Neutral conductor</li><li>• n.c.: Not connected (max. DC 30 V can be connected)</li><li>• AUX1: Protective-conductor terminal or potential bus (freely usable up to 230 VAC)</li></ul>
2	L1	6	L1	
3	N	7	N	
4	n.c.	8	n.c.	
A4	AUX1	A8	AUX1	
A3	AUX1	A7	AUX1	

Usable terminal modules

Usable terminal modules for 2DI 120 VAC Standard (6ES7131-4EB01-0AB0)				
TM-E15C26-A1 (6ES7193-4CA50-0AA0)	TM-E15C24-A1 (6ES7193-4CA30-0AA0)	TM-E15C24-01 (6ES7193-4CB30-0AA0)	TM-E15C23-01 (6ES7193-4CB10-0AA0)	← Spring terminal
TM-E15S26-A1 (6ES7193-4CA40-0AA0)	TM-E15S24-A1 (6ES7193-4CA20-0AA0)	TM-E15S24-01 (6ES7193-4CB20-0AA0)	TM-E15S23-01 (6ES7193-4CB00-0AA0)	← Screw terminal
TM-E15N26-A1 (6ES7193-4CA80-0AA0)	TM-E15N24-A1 (6ES7193-4CA70-0AA0)	TM-E15N24-01 (6ES7193-4CB70-0AA0)	TM-E15N23-01 (6ES7193-4CB60-0AA0)	← Fast Connect

Block diagram

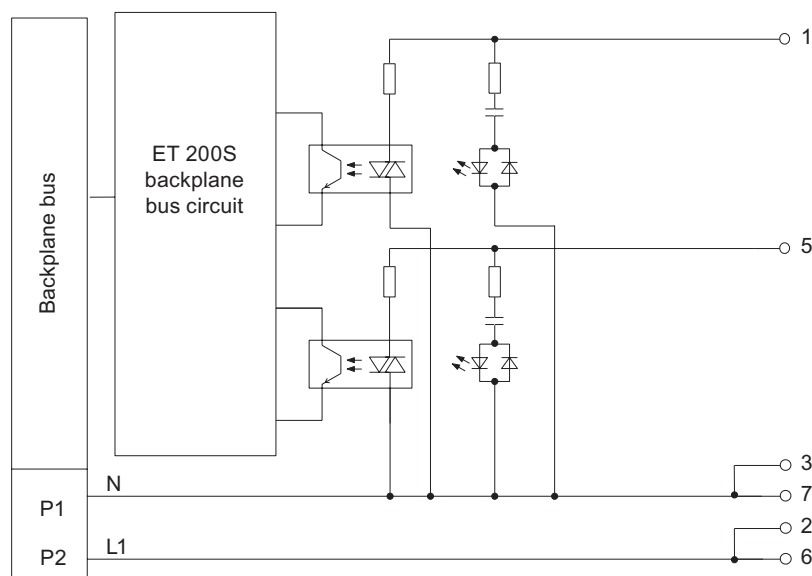

Figure 3-11 Block diagram of the 2DI 120 VAC Standard

**2DI 120 VAC Standard Technical Specifications (6ES7131-4EB01-0AB0)**

<b>Dimensions and Weight</b>	
Dimensions W × H × D (mm) (the total dimensions depend on the selected terminal module)	15 × 81 × 52
Weight	Approx. 31 g
<b>Data for specific modules</b>	
Supports isochronous operation	no
Number of inputs	2
Cable length	
• Unshielded	max. 600 m
• Shielded	max. 1000 m
Parameter length	3 bytes
<b>Voltages, currents, potentials</b>	
Supply voltage (from the power module)	120 VAC
• Frequency	47 to 63 Hz
Galvanic isolation	
• Between the channels	no
• Between the channels and backplane bus	Yes
Permissible potential difference	
• Between Minternal and the inputs	1500 VAC
Insulation test voltage	2500 VDC
Power dissipation of the module	Typically 0.5 W
<b>Status, interrupts, diagnostics</b>	
Status display	Green LED per channel
Diagnostics function	no
<b>Data for selecting a sensor</b>	
Input voltage	
• Rated value	120 VAC
• For signal "1"	79 VAC to 132 VAC
• For signal "0"	0 to 20 VAC
Input current	
• At signal "1"	3 to 9 mA
Input delay	
• At "0" to "1"	15 ms
• At "1" to "0"	25 ms
Input characteristic curve	according to IEC 61131, type 1
Connection of two-wire BEROs	no
• Permitted bias current	max. 1 mA



### 3.11 2DI 230 VAC Standard digital electronic module (6ES7131-4FB01-0AB0)

#### Properties

- Digital electronic module with two inputs
- Rated input voltage 230 VAC
- Suitable for switches

#### General terminal assignment

---

##### Note

Terminals 4, 8, A4, A8, A3 and A7 are only available at specified terminal modules.

---

Terminal assignment for 2DI 230 VAC Standard (6ES7131-4FB01-0AB0)				
Terminal	Assignment	Terminal	Assignment	Notes
1	DI <sub>0</sub>	5	DI <sub>1</sub>	<ul style="list-style-type: none"> <li>• DI<sub>n</sub>: Input signal, channel n</li> <li>• L1: Sensor power supply 230 VAC</li> <li>• N: Neutral conductor</li> <li>• n.c.: Not connected (max. DC 30 V can be connected)</li> <li>• AUX1: Protective-conductor terminal or potential bus (freely usable up to 230 VAC)</li> </ul>
2	L1	6	L1	
3	N	7	N	
4	n.c.	8	n.c.	
A4	AUX1	A8	AUX1	
A3	AUX1	A7	AUX1	

Usable terminal modules

Usable terminal modules for 2DI 230 VAC Standard (6ES7131-4FB01-0AB0)				
TM-E15C26-A1 (6ES7193-4CA50-0AA0)	TM-E15C24-A1 (6ES7193-4CA30-0AA0)	TM-E15C24-01 (6ES7193-4CB30-0AA0)	TM-E15C23-01 (6ES7193-4CB10-0AA0)	← Spring terminal
TM-E15S26-A1 (6ES7193-4CA40-0AA0)	TM-E15S24-A1 (6ES7193-4CA20-0AA0)	TM-E15S24-01 (6ES7193-4CB20-0AA0)	TM-E15S23-01 (6ES7193-4CB00-0AA0)	← Screw terminal
TM-E15N26-A1 (6ES7193-4CA80-0AA0)	TM-E15N24-A1 (6ES7193-4CA70-0AA0)	TM-E15N24-01 (6ES7193-4CB70-0AA0)	TM-E15N23-01 (6ES7193-4CB60-0AA0)	← Fast Connect
				<p>Wiring examples</p>

Block diagram

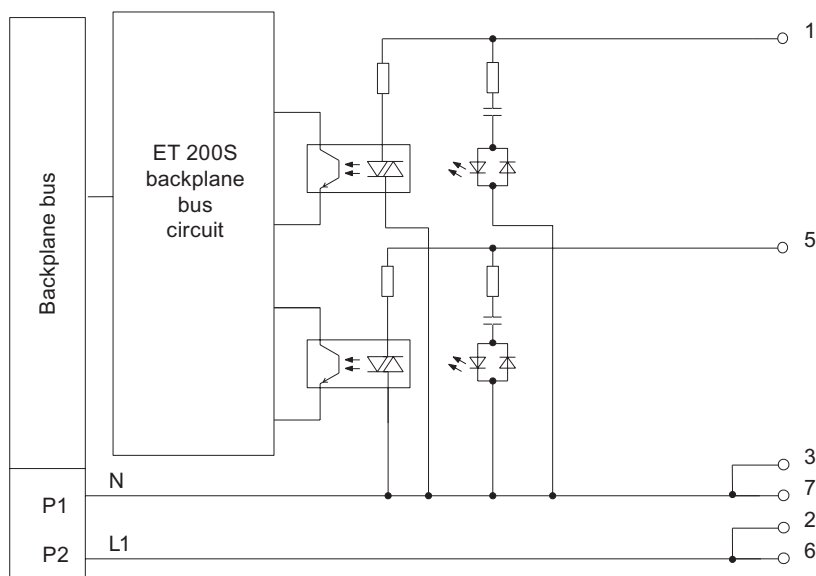

Figure 3-12 Block diagram of the 2DI 230 VAC Standard

## 2DI 230 VAC Standard Technical Specifications (6ES7131-4FB01-0AB0)

Dimensions and Weight	
Dimensions W × H × D (mm) (the total dimensions depend on the selected terminal module)	15 × 81 × 52
Weight	Approx. 31 g
Data for specific modules	
Supports isochronous operation	no
Number of inputs	2
Cable length	
• Unshielded	max. 600 m
• Shielded	max. 1000 m
Parameter length	3 bytes
Voltages, currents, potentials	
Supply voltage (from the power module)	230 VAC
• Frequency	47 to 63 Hz
Galvanic isolation	
• Between the channels	no
• Between the channels and backplane bus	Yes
Permissible potential difference	
• Between Minternal and the inputs	1500 VAC
Insulation test voltage	4000 VDC
Power dissipation of the module	Typically 0.7 W
Status, interrupts, diagnostics	
Status display	Green LED per channel
Diagnostics function	no
Data for selecting a sensor	
Input voltage	
• Rated value	230 VAC
• For signal "1"	164 to 264 VAC
• For signal "0"	0 to 40 V AC
Input current	
• At signal "1"	5 to 15 mA
Input delay	
• at "0" to "1"	15 ms
• At "1" to "0"	45 ms
Input characteristic curve	according to IEC 61131, type 1
Connection of two-wire BEROs	no
• Permitted bias current	max. 2 mA

### 3.12 2DO 24 VDC/0.5 A Standard digital electronic module (6ES7132-4BB01-0AA0)

#### Properties

- Digital electronic module with two outputs
- Output current 0.5 A per output
- Rated load voltage 24 VDC
- Short-circuit protection
- Suitable for solenoid valves, DC contactors, and indicator lights

#### Peculiarity

When you connect the 24 VDC rated load voltage to the power module by means of a mechanical contact, depending on the circuit the digital outputs carry the "1" signal for approximately 50 µs. You need to take this into account if you connect the module to fast counters.

#### General terminal assignment

---

##### Note

Terminals 4, 8, A4, A8, A3 and A7 are only available at specified terminal modules.

---

Terminal assignment for 2DO 24 VDC/0.5 A Standard (6ES7132-4BB01-0AA0)				
Terminal	Assignment	Terminal	Assignment	Notes
1	DO <sub>0</sub>	5	DO <sub>1</sub>	<ul style="list-style-type: none"> <li>• DO<sub>n</sub>: Output signal, channel n</li> <li>• L+ Rated load voltage 24 VDC</li> <li>• M: Chassis ground</li> <li>• n.c.: Not connected (max. DC 30 V can be connected)</li> <li>• AUX1: Protective-conductor terminal or potential bus (freely usable up to 230 VAC)</li> </ul>
2	L+	6	L+	
3	M	7	M	
4	n.c.	8	n.c.	
A4	AUX1	A8	AUX1	
A3	AUX1	A7	AUX1	

Usable terminal modules

Usable terminal modules for 2DO 24 VDC/0.5 A Standard (6ES7132-4BB01-0AA0)				
TM-E15C26-A1 (6ES7193-4CA50-0AA0)	TM-E15C24-A1 (6ES7193-4CA30-0AA0)	TM-E15C24-01 (6ES7193-4CB30-0AA0)	TM-E15C23-01 (6ES7193-4CB10-0AA0)	← Spring terminal
TM-E15S26-A1 (6ES7193-4CA40-0AA0)	TM-E15S24-A1 (6ES7193-4CA20-0AA0)	TM-E15S24-01 (6ES7193-4CB20-0AA0)	TM-E15S23-01 (6ES7193-4CB00-0AA0)	← Screw terminal
TM-E15N26-A1 (6ES7193-4CA80-0AA0)	TM-E15N24-A1 (6ES7193-4CA70-0AA0)	TM-E15N24-01 (6ES7193-4CB70-0AA0)	TM-E15N23-01 (6ES7193-4CB60-0AA0)	← Fast Connect

Block diagram

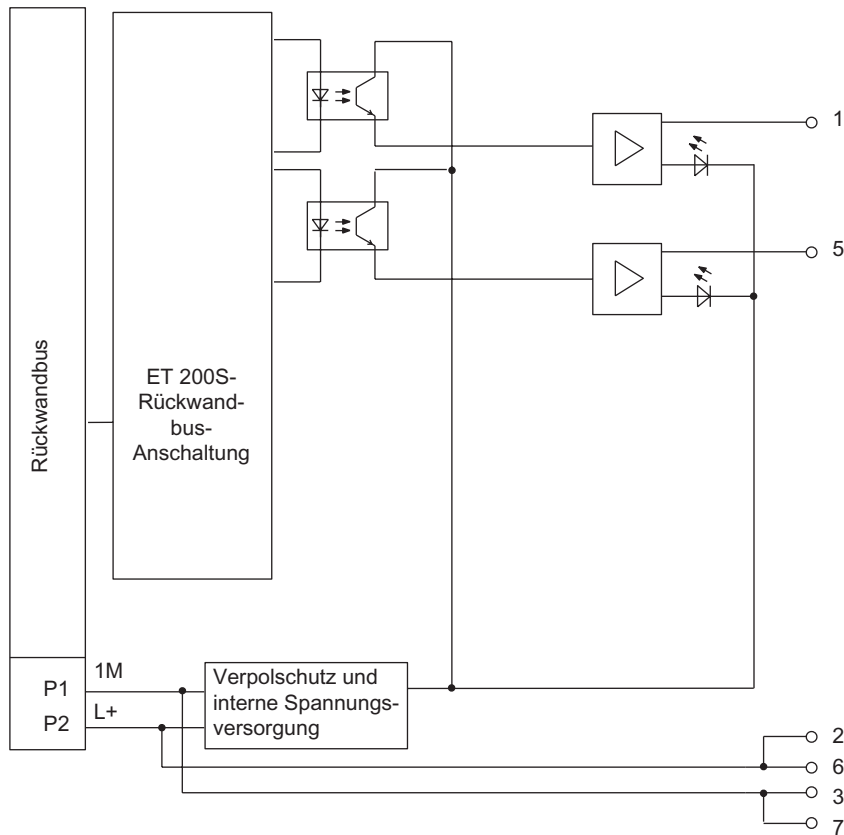

Figure 3-13 Block diagram of the 2DO 24 VDC/0.5 A Standard

2DO 24 VDC/0.5 A Standard Technical Specifications (6ES7132-4BB01-0AA0)

Dimensions and Weight	
Dimensions W × H × D (mm) (the total dimensions depend on the selected terminal module)	15 × 81 × 52
Weight	Approx. 40 g
Data for specific modules	
Supports isochronous operation	no
Number of outputs	2
Cable length	
• Unshielded	max. 600 m
• Shielded	max. 1000 m
Parameter length	1 byte
Voltages, currents, potentials	
Rated load voltage L+ (from the power module)	24 VDC
• Reverse polarity protection	Yes <sup>1</sup>
Total current of the outputs (per module)	1 A

## 3.12 2DO 24 VDC/0.5 A Standard digital electronic module (6ES7132-4BB01-0AA0)

Galvanic isolation	
• Between the channels	no
• Between the channels and backplane bus	Yes
Permissible potential difference	
• Between the different circuits	75 VDC / 60 VAC
Insulation tested	500 VDC
Current consumption	
• From the load voltage L+ (no load)	max. 5 mA per channel
Power dissipation of the module	Typically 0.4 W
<b>Status, interrupts, diagnostics</b>	
Status display	Green LED per channel
Diagnostics function	no
<b>Data for selecting an actuator</b>	
Output voltage	
• At signal "1"	min. L+ (-1 V)
Output current	
• At signal "1"	
– Rated value	0.5 A
– Permitted range	7 mA to 0.6 A
• With signal "0" (leakage current)	max. 0.3 mA
Output delay (for resistive load)	
• at "0" to "1"	max. 200 $\mu$ s
• At "1" to "0"	max. 1.3 ms
Load resistor range	48 $\Omega$ to 3.4 k $\Omega$
Lamp load	max. 5 W
Connecting two outputs in parallel	
• For redundant triggering of a load	Yes (per module)
• To increase performance	no
Control of a digital input	Yes
Switch rate	
• For resistive load	100 Hz
• On inductive load	2 Hz
• For lamp load	10 Hz
Limitation (internal) of the voltage induced on circuit interruption	Typically L+ (-55 to -60 V)
Reverse-voltage proof	Yes, if using the same load voltage as at the power module
Short-circuit protection of the output	Yes <sup>2</sup>
• Threshold on	Typ. 0.7 A to 1.8 A
<sup>1</sup> Polarity reversal can lead to the digital outputs being connected through.	
<sup>2</sup> Per channel	

### 3.13 Standard digital electronic module 4DO 24 VDC/0.5 A (6ES7132-4BD01-0AA0)

#### Properties

- Digital electronic module with four outputs
- Output current 0.5 A per output
- Rated load voltage 24 VDC
- Short-circuit protection
- Suitable for solenoid valves, DC contactors, and indicator lights

#### Peculiarity

When you connect the 24 VDC rated load voltage to the power module by means of a mechanical contact, depending on the circuit the digital outputs carry the "1" signal for approximately 50 µs. You need to take this into account if you connect the module to fast counters.

#### General terminal assignment

---

#### Note

Terminals 4, 8, A4, A8, A3 and A7 are only available at specified terminal modules.

---

Terminal assignment for 4DO 24 VDC/0.5 A Standard (6ES7132-4BD01-0AA0)				
Terminal	Assignment	Terminal	Assignment	Notes
1	DO <sub>0</sub>	5	DO <sub>1</sub>	<ul style="list-style-type: none"> <li>• DO<sub>n</sub>: Output signal, channel n</li> <li>• M: Chassis ground</li> <li>• AUX1: Protective-conductor terminal or potential bus (freely usable up to 230 VAC)</li> </ul>
2	DO <sub>2</sub>	6	DO <sub>3</sub>	
3	M	7	M	
4	M	8	M	
A4	AUX1	A8	AUX1	
A3	AUX1	A7	AUX1	



Usable terminal modules

Usable terminal modules for 4DO 24 VDC/0.5 A Standard (6ES7132-4BD01-0AA0)				
TM-E15C26-A1 (6ES7193-4CA50-0AA0)	TM-E15C24-A1 (6ES7193-4CA30-0AA0)	TM-E15C24-01 (6ES7193-4CB30-0AA0)	TM-E15C23-01 (6ES7193-4CB10-0AA0)	← Spring terminal
TM-E15S26-A1 (6ES7193-4CA40-0AA0)	TM-E15S24-A1 (6ES7193-4CA20-0AA0)	TM-E15S24-01 (6ES7193-4CB20-0AA0)	TM-E15S23-01 (6ES7193-4CB00-0AA0)	← Screw terminal
TM-E15N26-A1 (6ES7193-4CA80-0AA0)	TM-E15N24-A1 (6ES7193-4CA70-0AA0)	TM-E15N24-01 (6ES7193-4CB70-0AA0)	TM-E15N23-01 (6ES7193-4CB60-0AA0)	← Fast Connect

Block diagram

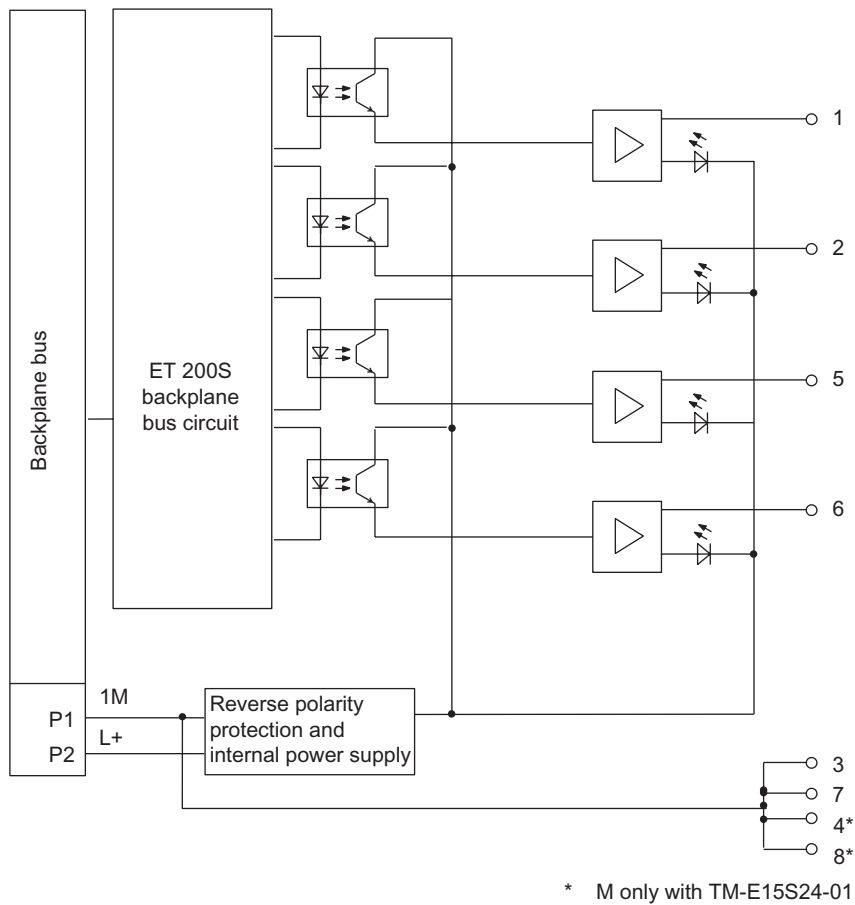

\* M only with TM-E15S24-01

Figure 3-14 Block diagram of the 4DO 24 VDC/0.5 A Standard

Technical Specifications 4DO 24 VDC/0.5 A Standard (6ES7132-4BD01-0AA0)

Dimensions and Weight	
Dimensions W × H × D (mm) (the total dimensions depend on the selected terminal module)	15 × 81 × 52
Weight	Approx. 40 g
Data for specific modules	
Supports isochronous operation	Yes
Number of outputs	4
Cable length	
• Unshielded	max. 600 m
• Shielded	max. 1000 m
Parameter length	1 byte

## 3.13 Standard digital electronic module 4DO 24 VDC/0.5 A (6ES7132-4BD01-0AA0)

<b>Voltages, currents, potentials</b>	
Rated load voltage L+ (from the power module)	24 VDC
• Reverse polarity protection	Yes <sup>1</sup>
Total current of the outputs (per module)	2 A
Galvanic isolation	
• Between the channels	no
• Between the channels and backplane bus	Yes
Permissible potential difference	
• Between the different circuits	75 VDC / 60 VAC
Insulation tested	500 VDC
Current consumption	
• From the load voltage L+ (no load)	max. 5 mA per channel
Power dissipation of the module	Typically 0.8 W
Status, interrupts, diagnostics	
Status display	Green LED per channel
Diagnostics function	no
<b>Data for selecting an actuator</b>	
Output voltage	
• At signal "1"	min. L+ (-1 V)
Output current	
• At signal "1"	
– Rated value	0.5 A
– Permitted range	7 mA to 0.6 A
• With signal "0" (leakage current)	max. 0.3 mA
Output delay (for resistive load)	
• at "0" to "1"	max. 100 µs
• At "1" to "0"	max. 300 µs
Load resistor range	48 Ω to 3.4 kΩ
Lamp load	max. 5 W
Connecting two outputs in parallel	
• For redundant triggering of a load	Yes (per module)
• To increase performance	no
Control of a digital input	Yes
Switch rate	
• For resistive load	100 Hz
• On inductive load	2 Hz
• For lamp load	10 Hz
Limitation (internal) of the voltage induced on circuit interruption	Typically L+ (-55 to -60 V)
Reverse-voltage proof	Yes, if using the same load voltage as at the power module <sup>2</sup>
Short-circuit protection of the output	Yes <sup>3</sup>
• Threshold on	Typ. 0.7 A to 1.5 A
<sup>1</sup> Polarity reversal can lead to the digital outputs being connected through. <sup>2</sup> The module must be supplied with voltage. <sup>3</sup> Per channel	

### 3.14 2DO 24 VDC/0.5 A High Feature digital electronic module (6ES7132-4BB01-0AB0)

#### Properties

- Digital electronic module with two outputs
- Output current 0.5 A per output
- Rated load voltage 24 VDC
- Diagnostics: Wire break
- Diagnostics: Short circuit
- Short-circuit protection
- Suitable for solenoid valves, DC contactors, and indicator lights
- Supports isochronous operation

#### Peculiarity

When you connect the 24 VDC rated load voltage to the power module by means of a mechanical contact, depending on the circuit the digital outputs carry the "1" signal for approximately 50 µs. You need to take this into account if you connect the module to fast counters.

#### General terminal assignment

---

#### Note

Terminals 4, 8, A4, A8, A3 and A7 are only available at specified terminal modules.

---

Terminal assignment for 2DO 24 VDC/0.5 A High Feature (6ES7132-4BB01-0AA0)				
Terminal	Assignment	Terminal	Assignment	Notes
1	DO <sub>0</sub>	5	DO <sub>1</sub>	<ul style="list-style-type: none"> <li>• DO<sub>n</sub>: Output signal, channel n</li> <li>• L+: Rated load voltage 24 VDC</li> <li>• M: Ground</li> <li>• n.c.: Not connected (max. 30 VDC can be connected)</li> <li>• AUX1: Protective-conductor terminal or potential bus (freely usable up to 230 VAC)</li> </ul>
2	L+	6	L+	
3	M	7	M	
4	n.c.	8	n.c.	
A4	AUX1	A8	AUX1	
A3	AUX1	A7	AUX1	

Usable terminal modules

Usable terminal modules for 2DO 24 VDC/0.5 A High Feature (6ES7132-4BB01-0AA0)				
TM-E15C26-A1 (6ES7193-4CA50-0AA0)	TM-E15C24-A1 (6ES7193-4CA30-0AA0)	TM-E15C24-01 (6ES7193-4CB30-0AA0)	TM-E15C23-01 (6ES7193-4CB10-0AA0)	← Spring terminal
TM-E15S26-A1 (6ES7193-4CA40-0AA0)	TM-E15S24-A1 (6ES7193-4CA20-0AA0)	TM-E15S24-01 (6ES7193-4CB20-0AA0)	TM-E15S23-01 (6ES7193-4CB00-0AA0)	← Screw terminal
TM-E15N26-A1 (6ES7193-4CA80-0AA0)	TM-E15N24-A1 (6ES7193-4CA70-0AA0)	TM-E15N24-01 (6ES7193-4CB70-0AA0)	TM-E15N23-01 (6ES7193-4CB60-0AA0)	← Fast Connect

Block diagram

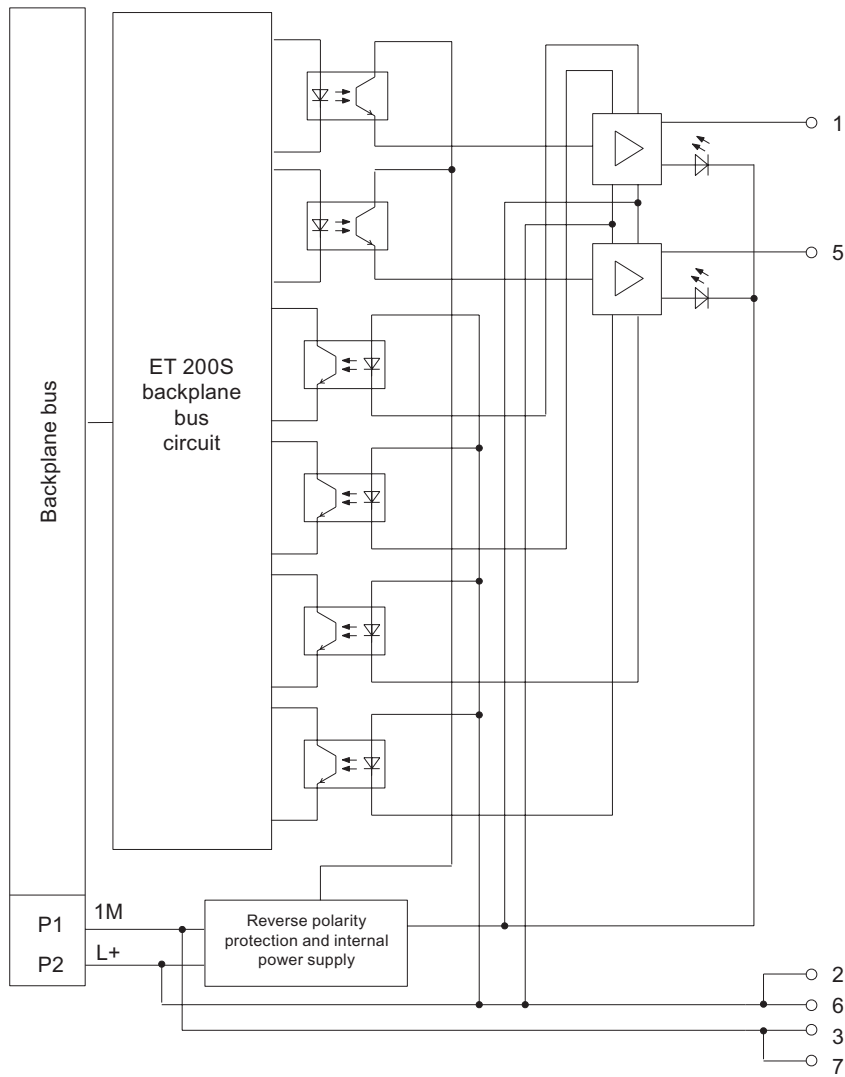

Figure 3-15 Block diagram of the 2DO 24 VDC/0.5 A High Feature

## 2DO 24 VDC/0.5 A High Feature Technical Specifications (6ES7132-4BB01-0AB0)

Dimensions and Weight	
Dimensions W × H × D (mm) (the total dimensions depend on the selected terminal module)	15 × 81 × 52
Weight	Approx. 40 g
Data for specific modules	
Supports isochronous operation	Yes
Number of outputs	2
Cable length	
• Unshielded	max. 600 m
• Shielded	max. 1000 m
Parameter length	3 bytes
Voltages, currents, potentials	
Rated load voltage L+ (from the power module)	24 VDC
• Reverse polarity protection	Yes <sup>1</sup>
Total current of the outputs (per module)	1 A
Galvanic isolation	
• Between the channels	no
• Between the channels and backplane bus	Yes
Permissible potential difference	
• Between the different circuits	75 VDC / 60 VAC
Insulation tested	500 VDC
Current consumption	
• From the load voltage L+ (no load)	max. 5 mA per channel
Power dissipation of the module	Typically 0.4 W
Status, interrupts, diagnostics	
Status display	Green LED per channel
Diagnostics function	
• Group error	Red "SF" LED
• Diagnostic functions readable	Yes
Data for selecting an actuator	
Output voltage	
• At signal "1"	min. L+ (-1 V)
Output current	
• At signal "1"	
– Rated value	0.5 A
– Permitted range	7 mA to 0.6 A
• With signal "0" (leakage current)	max. 0.3 mA
Output delay (for resistive load)	
• at "0" to "1"	max. 100 μs
• At "1" to "0"	max. 400 μs
Load resistor range	48 Ω to 3.4 kΩ

Lamp load	max. 2.5 W
Connecting two outputs in parallel	
<ul style="list-style-type: none"> <li>For redundant triggering of a load</li> </ul>	Yes (per module)
<ul style="list-style-type: none"> <li>To increase performance</li> </ul>	no
Control of a digital input	Yes
Switch rate	
<ul style="list-style-type: none"> <li>For resistive load</li> </ul>	100 Hz
<ul style="list-style-type: none"> <li>On inductive load</li> </ul>	2 Hz
<ul style="list-style-type: none"> <li>For lamp load</li> </ul>	10 Hz
Limitation (internal) of the voltage induced on circuit interruption	Typically L+ (-55 V to -60 V)
Reverse-voltage proof	Yes, if using the same load voltage as at the power module
Short-circuit protection of the output	Yes <sup>2</sup>
<ul style="list-style-type: none"> <li>Threshold on</li> </ul>	Typically 1.5 A
<sup>1</sup> Polarity reversal can lead to the digital outputs being connected through.	
<sup>2</sup> Per channel	

### 3.15 2DO 24 VDC/2 A Standard digital electronic module (6ES7132-4BB31-0AA0)

#### Properties

- Digital electronic module with two outputs
- Output current 2 A per output
- Rated load voltage 24 VDC
- Short-circuit protection
- Suitable for solenoid valves, DC contactors, and indicator lights

#### Peculiarity

When you connect the 24 VDC rated load voltage to the power module by means of a mechanical contact, depending on the circuit the digital outputs carry the "1" signal for approximately 50 µs. You need to take this into account if you connect the module to fast counters.



### General terminal assignment

**Note**

Terminals 4, 8, A4, A8, A3 and A7 are only available at specified terminal modules.

Terminal assignment for 2DO 24 VDC/2 A Standard (6ES7132-4BB31-0AA0)				
Terminal	Assignment	Terminal	Assignment	Notes
1	DO <sub>0</sub>	5	DO <sub>1</sub>	<ul style="list-style-type: none"> <li>DO<sub>n</sub>: Output signal, channel n</li> <li>L+: Rated load voltage 24 VDC</li> <li>M: Ground</li> <li>n.c.: Not connected (max. DC 30 V can be connected)</li> <li>AUX1: Protective-conductor terminal or potential bus (freely usable up to 230 VAC)</li> </ul>
2	L+	6	L+	
3	M	7	M	
4	n.c.	8	n.c.	
A4	AUX1	A8	AUX1	
A3	AUX1	A7	AUX1	

### Usable terminal modules

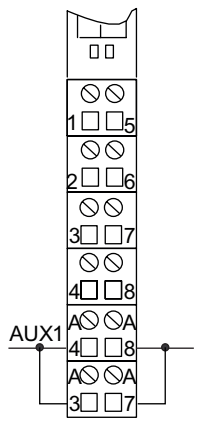
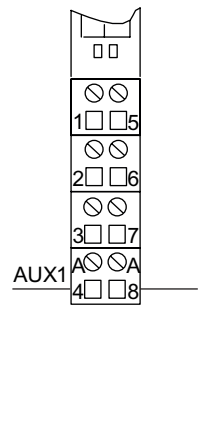
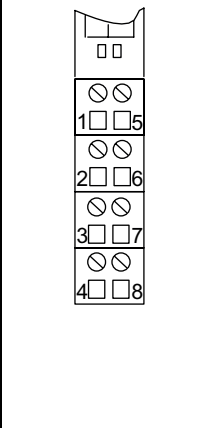
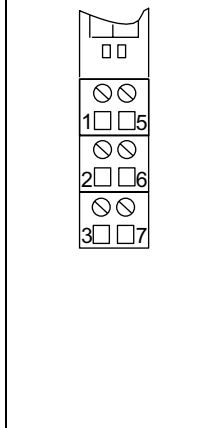
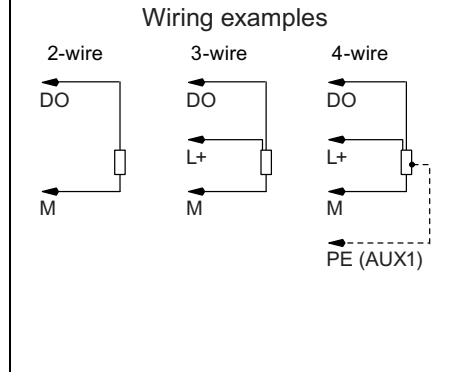
Usable terminal modules for 2DO 24 VDC/2 A Standard (6ES7132-4BB31-0AA0)				
TM-E15C26-A1 (6ES7193-4CA50-0AA0)	TM-E15C24-A1 (6ES7193-4CA30-0AA0)	TM-E15C24-01 (6ES7193-4CB30-0AA0)	TM-E15C23-01 (6ES7193-4CB10-0AA0)	← Spring terminal
TM-E15S26-A1 (6ES7193-4CA40-0AA0)	TM-E15S24-A1 (6ES7193-4CA20-0AA0)	TM-E15S24-01 (6ES7193-4CB20-0AA0)	TM-E15S23-01 (6ES7193-4CB00-0AA0)	← Screw terminal
TM-E15N26-A1 (6ES7193-4CA80-0AA0)	TM-E15N24-A1 (6ES7193-4CA70-0AA0)	TM-E15N24-01 (6ES7193-4CB70-0AA0)	TM-E15N23-01 (6ES7193-4CB60-0AA0)	← Fast Connect
				<p>Wiring examples</p> 

Block diagram

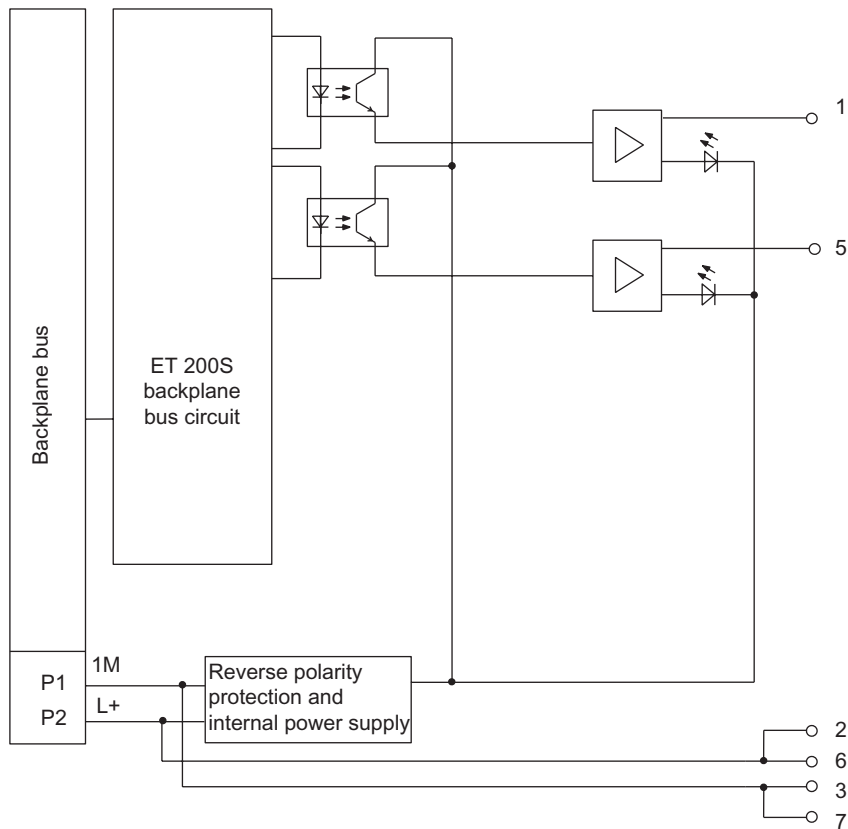

Figure 3-16 Block diagram of the 2DO 24 VDC/2 A Standard

2DO 24 VDC/2 A Standard Technical Specifications (6ES7132-4BB31-0AA0)

Dimensions and Weight	
Dimensions W × H × D (mm) (the total dimensions depend on the selected terminal module)	15 × 81 × 52
Weight	Approx. 40 g
Data for specific modules	
Supports isochronous operation	no
Number of outputs	2
Cable length	
• Unshielded	max. 600 m
• Shielded	max. 1000 m
Parameter length	1 byte
Voltages, currents, potentials	
Rated load voltage L+ (from the power module)	24 VDC
• Polarity reversal	Yes <sup>1</sup>
Total current of the outputs (per module)	4 A

## 3.15 2DO 24 VDC/2 A Standard digital electronic module (6ES7132-4BB31-0AA0)

Galvanic isolation	
• Between the channels	no
• Between the channels and backplane bus	Yes
Permissible potential difference	
• Between the different circuits	75 VDC / 60 VAC
Insulation tested	500 VDC
Current consumption	
• From the rated load voltage L+ (no load)	max. 5 mA per channel
Power dissipation of the module	Typically 1.4 W
<b>Status, interrupts, diagnostics</b>	
Status display	Green LED per channel
Diagnostics function	no
<b>Data for selecting an actuator</b>	
Output voltage	
• At signal "1"	min. L+ (-1 V)
Output current	
• At signal "1"	
– Rated value	2 A
– Permitted range	7 mA to 2.4 A
• With signal "0" (leakage current)	max. 0.5 mA
Output delay (for resistive load)	
• at "0" to "1"	max. 200 µs
• At "1" to "0"	max. 1.3 ms
Load resistor range	12 Ω to 3.4 k Ω
Lamp load	max. 10 W
Connecting two outputs in parallel	
• For redundant triggering of a load	Yes (per module)
• To increase performance	no
Control of a digital input	Yes
Switch rate	
• For resistive load	100 Hz
• On inductive load	2 Hz (0.5 H)
• For lamp load	10 Hz
Limitation (internal) of the voltage induced on circuit interruption	Typically L+ (-55 V to -60 V)
Reverse-voltage proof	Yes, if using the same load voltage as at the power module
Short-circuit protection of the output	Yes <sup>2</sup>
• Threshold on	Typically 2.8 A to 7.2 A
<sup>1</sup> Polarity reversal can lead to the digital outputs being connected through.	
<sup>2</sup> Per channel	

### 3.16 4DO 24 VDC/2 A Standard digital electronic module (6ES7132-4BD31-0AA0)

#### Properties

- Digital electronic module with four outputs
- Output current 2 A per output
- Rated load voltage 24 VDC
- Short-circuit protection
- Suitable for solenoid valves, DC contactors, and indicator lights

#### Peculiarity

When you connect the 24 VDC rated load voltage to the power module by means of a mechanical contact, depending on the circuit the digital outputs carry the "1" signal for approximately 50 µs. You need to take this into account if you connect the module to fast counters.

#### General terminal assignment

---

#### Note

Terminals 4, 8, A4, A8, A3 and A7 are only available at specified terminal modules.

---

Terminal assignment for 4DO 24 VDC/2 A Standard (6ES7132-4BD31-0AA0)				
Terminal	Assignment	Terminal	Assignment	Notes
1	DO <sub>0</sub>	5	DO <sub>1</sub>	<ul style="list-style-type: none"> <li>• DO<sub>n</sub>: Output signal, channel n</li> <li>• M: Ground</li> <li>• AUX1: Protective-conductor terminal or potential bus (freely usable up to 230 VAC)</li> </ul>
2	DO <sub>2</sub>	6	DO <sub>3</sub>	
3	M	7	M	
4	M	8	M	
A4	AUX1	A8	AUX1	
A3	AUX1	A7	AUX1	

Usable terminal modules

Usable terminal modules for 4DO 24 VDC/2 A Standard (6ES7132-4BD31-0AA0)				
TM-E15C26-A1 (6ES7193-4CA50-0AA0)	TM-E15C24-A1 (6ES7193-4CA30-0AA0)	TM-E15C24-01 (6ES7193-4CB30-0AA0)	TM-E15C23-01 (6ES7193-4CB10-0AA0)	← Spring terminal
TM-E15S26-A1 (6ES7193-4CA40-0AA0)	TM-E15S24-A1 (6ES7193-4CA20-0AA0)	TM-E15S24-01 (6ES7193-4CB20-0AA0)	TM-E15S23-01 (6ES7193-4CB00-0AA0)	← Screw terminal
TM-E15N26-A1 (6ES7193-4CA80-0AA0)	TM-E15N24-A1 (6ES7193-4CA70-0AA0)	TM-E15N24-01 (6ES7193-4CB70-0AA0)	TM-E15N23-01 (6ES7193-4CB60-0AA0)	← Fast Connect
<p style="text-align: center;">Wiring examples</p> <p>The diagram illustrates four terminal module configurations and two wiring examples. The first three columns show terminal layouts for TM-E15C26-A1, TM-E15C24-A1, and TM-E15N26-A1. The fourth column shows terminal layouts for TM-E15C24-01, TM-E15S24-01, and TM-E15N24-01. The fifth column shows two wiring examples: a 2-wire configuration and a configuration with PE (AUX1) terminals.</p>				

Block diagram

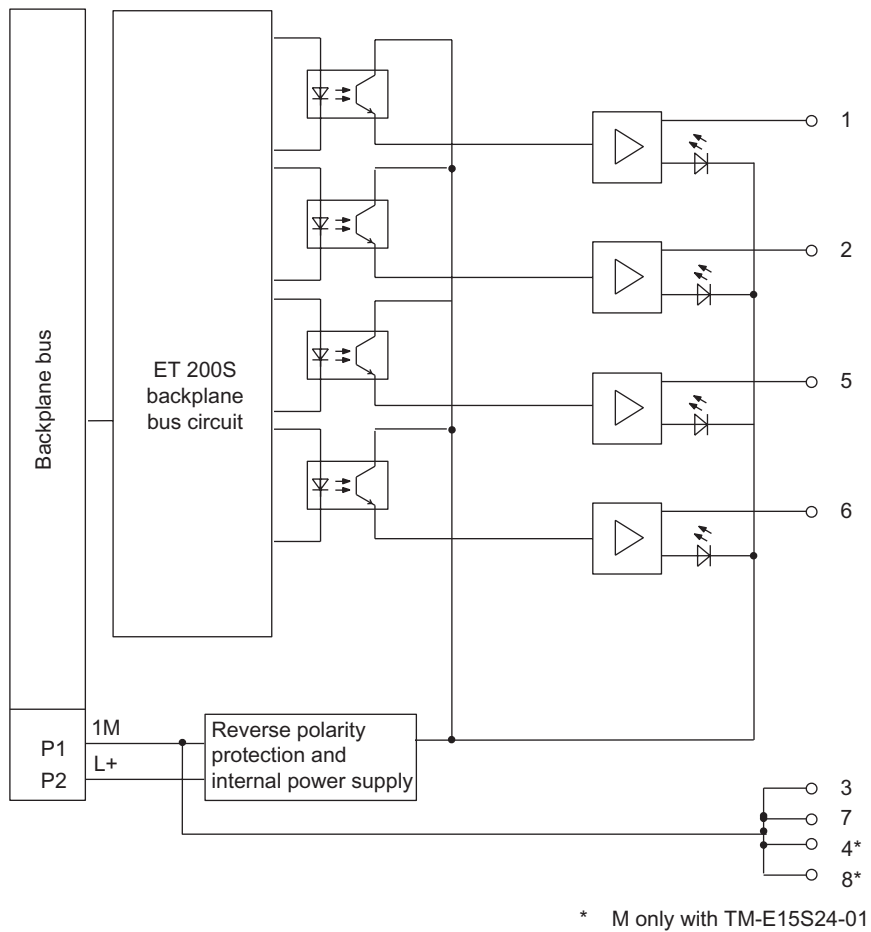

Figure 3-17 Block diagram of the 4DO 24 VDC/2 A Standard

4DO 24 VDC/2 A Standard Technical Specifications (6ES7132-4BD31-0AA0)

Dimensions and Weight	
Dimensions W × H × D (mm) (the total dimensions depend on the selected terminal module)	15 × 81 × 52
Weight	Approx. 40 g
Data for specific modules	
Supports isochronous operation	no
Number of outputs	4
Cable length	
• Unshielded	max. 600 m
• Shielded	max. 1000 m
Parameter length	1 byte

<b>Voltages, currents, potentials</b>	
Rated load voltage L+ (from the power module)	24 VDC
• Polarity reversal	Yes <sup>1</sup>
Total current of the outputs (per module)	4 A
Galvanic isolation	
• Between the channels	no
• Between the channels and backplane bus	Yes
Permissible potential difference	
• Between the different circuits	75 VDC / 60 VAC
Insulation tested	500 VDC
Current consumption	
• From the rated load voltage L+ (no load)	max. 5 mA per channel
Power dissipation of the module	Typically 1.6 W
<b>Status, interrupts, diagnostics</b>	
Status display	Green LED per channel
Diagnostics function	no
<b>Data for selecting an actuator</b>	
Output voltage	
• At signal "1"	min. L+ (-1 V)
Output current	
• At signal "1"	
– Rated value	2 A
– Permitted range	7 mA to 2.4 A
• With signal "0" (leakage current)	max. 0.5 mA
Output delay (for resistive load)	
• at "0" to "1"	max. 200 µs
• At "1" to "0"	max. 1.3 ms
Load resistor range	12 Ω to 3.4 k Ω
Lamp load	max. 10 W
Connecting two outputs in parallel	
• For redundant triggering of a load	Yes (per module)
• To increase performance	no
Control of a digital input	Yes
Switch rate	
• For resistive load	100 Hz
• On inductive load	2 Hz (0.5 H)
• For lamp load	10 Hz
Limitation (internal) of the voltage induced on circuit interruption	Typically L+ (-55 to -60 V)
Reverse-voltage proof	Yes, if using the same load voltage as at the power module
Short-circuit protection of the output	Yes <sup>2</sup>
• Threshold on	Typically 2.8 A to 7.2 A
<sup>1</sup> Polarity reversal can lead to the digital outputs being connected through.	
<sup>2</sup> Per channel	

### 3.17 2DO 24 VDC/2 A High Feature digital electronic module (6ES7132-4BB31-0AB0)

#### Properties

- Digital electronic module with two outputs
- Output current 2 A per output
- Rated load voltage 24 VDC
- Diagnostics: Wire break
- Diagnostics: Short circuit
- Short-circuit protection
- Suitable for solenoid valves, DC contactors, and indicator lights
- Supports isochronous operation

#### Peculiarity

When you connect the 24 VDC rated load voltage to the power module by means of a mechanical contact, depending on the circuit the digital outputs carry the "1" signal for approximately 50 µs. You need to take this into account if you connect the module to fast counters.

#### General terminal assignment

---

##### Note

Terminals 4, 8, A4, A8, A3 and A7 are only available at specified terminal modules.

---

Terminal assignment for 2DO 24 VDC/2 A High Feature (6ES7132-4BB31-0AA0)				
Terminal	Assignment	Terminal	Assignment	Notes
1	DO <sub>0</sub>	5	DO <sub>1</sub>	<ul style="list-style-type: none"> <li>• DO<sub>n</sub>: Output signal, channel n</li> <li>• L+ Rated load voltage 24 VDC</li> <li>• M: Chassis ground</li> <li>• n.c.: Not connected (max. 30 VDC can be connected)</li> <li>• AUX1: Protective-conductor terminal or potential bus (freely usable up to 230 VAC)</li> </ul>
2	L+	6	L+	
3	M	7	M	
4	n.c.	8	n.c.	
A4	AUX1	A8	AUX1	
A3	AUX1	A7	AUX1	



Usable terminal modules

Usable terminal modules for 2DO 24 VDC/2 A High Feature (6ES7132-4BB31-0AA0)				
TM-E15C26-A1 (6ES7193-4CA50-0AA0)	TM-E15C24-A1 (6ES7193-4CA30-0AA0)	TM-E15C24-01 (6ES7193-4CB30-0AA0)	TM-E15C23-01 (6ES7193-4CB10-0AA0)	← Spring terminal
TM-E15S26-A1 (6ES7193-4CA40-0AA0)	TM-E15S24-A1 (6ES7193-4CA20-0AA0)	TM-E15S24-01 (6ES7193-4CB20-0AA0)	TM-E15S23-01 (6ES7193-4CB00-0AA0)	← Screw terminal
TM-E15N26-A1 (6ES7193-4CA80-0AA0)	TM-E15N24-A1 (6ES7193-4CA70-0AA0)	TM-E15N24-01 (6ES7193-4CB70-0AA0)	TM-E15N23-01 (6ES7193-4CB60-0AA0)	← Fast Connect

Block diagram

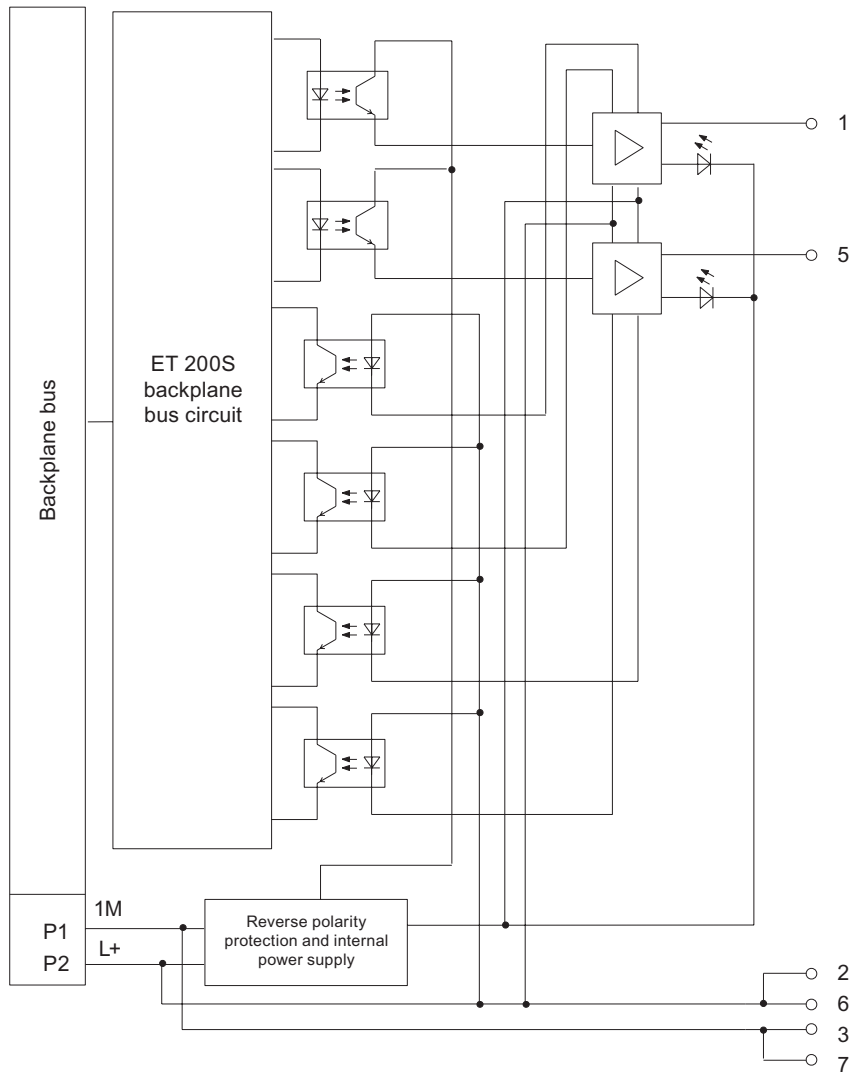

Figure 3-18 Block diagram of the 2DO 24 VDC/2 A High Feature

## 2DO 24 VDC/2 A High Feature Technical Specifications (6ES7132-4BB31-0AB0)

Dimensions and Weight	
Dimensions W × H × D (mm) (the total dimensions depend on the selected terminal module)	15 × 81 × 52
Weight	Approx. 40 g
Data for specific modules	
Supports isochronous operation	Yes
Number of outputs	2
Cable length	
• Unshielded	max. 600 m
• Shielded	max. 1000 m
Parameter length	3 bytes
Voltages, currents, potentials	
Rated load voltage L+ (from the power module)	24 VDC
• Polarity reversal	Yes <sup>1</sup>
Total current of the outputs (per module)	4 A
Galvanic isolation	
• Between the channels	no
• Between the channels and backplane bus	Yes
Permissible potential difference	
• Between the different circuits	75 VDC / 60 VAC
Insulation tested	500 VDC
Current consumption	
• From the rated load voltage L+ (no load)	max. 5 mA per channel
Power dissipation of the module	Typically 1.4 W
Status, interrupts, diagnostics	
Status display	Green LED per channel
Diagnostics function	
• General fault	Red "SF" LED
• Diagnostic functions readable	Yes
Data for selecting an actuator	
Output voltage	
• At signal "1"	min. L+ (-1 V)
Output current	
• At signal "1"	
– Rated value	2 A
– Permitted range	7 mA to 2.4 A
• With signal "0" (leakage current)	max. 0.5 mA
Output delay (for resistive load)	
• at "0" to "1"	max. 100 μs
• At "1" to "0"	max. 400 μs
Load resistor range	12 Ω to 3.4 k Ω

Lamp load	max. 5 W
Connecting two outputs in parallel	
<ul style="list-style-type: none"> <li>• For redundant triggering of a load</li> </ul>	Yes (per module)
<ul style="list-style-type: none"> <li>• To increase performance</li> </ul>	no
Control of a digital input	Yes
Switch rate	
<ul style="list-style-type: none"> <li>• For resistive load</li> </ul>	100 Hz
<ul style="list-style-type: none"> <li>• On inductive load</li> </ul>	2 Hz (0.5 H)
<ul style="list-style-type: none"> <li>• For lamp load</li> </ul>	10 Hz
Limitation (internal) of the voltage induced on circuit interruption	Typically L+ (-55 to -60 V)
Reverse-voltage proof	Yes, if using the same load voltage as at the power module
Short-circuit protection of the output	Yes <sup>2</sup>
<ul style="list-style-type: none"> <li>• Threshold on</li> </ul>	Typically 4 A
<sup>1</sup> Polarity reversal can lead to the digital outputs being connected through. <sup>2</sup> Per channel	

### 3.18 2DO 24 VAC to 230 VAC digital electronic module (6ES7132-4FB01-0AB0)

#### Properties

- Digital electronic module with two outputs
- Output current 2 A per output
- Rated load voltage 24 VAC to 48/120/230 VAC
- Replacement value
- Suitable for solenoid valves, AC contactors, and indicator lights

#### General terminal assignment

---

##### Note

Terminals 4, 8, A4, A8, A3 and A7 are only available at specified terminal modules.

---

Terminal assignment for 2DO 24 VAC to 230 VAC (6ES7132-4FB01-0AB0)				
Terminal	Assignment	Terminal	Assignment	Notes
1	DO <sub>0</sub>	5	DO <sub>1</sub>	<ul style="list-style-type: none"> <li>• DO<sub>n</sub>: Output signal, channel n</li> <li>• N: Neutral conductor</li> <li>• n.c.: Not connected (max. DC 30 V can be connected)</li> <li>• AUX1: Protective-conductor terminal or potential bus (freely usable up to 230 VAC)</li> </ul>
2	n.c.	6	n.c.	
3	N	7	N	
4	n.c.	8	n.c.	
A4	AUX1	A8	AUX1	
A3	AUX1	A7	AUX1	

Usable terminal modules

Usable terminal modules for 2DO 24 VAC to 230 VAC (6ES7132-4FB01-0AB0)				
TM-E15C26-A1 (6ES7193-4CA50-0AA0)	TM-E15C24-A1 (6ES7193-4CA30-0AA0)	TM-E15C24-01 (6ES7193-4CB30-0AA0)	TM-E15C23-01 (6ES7193-4CB10-0AA0)	← Spring terminal
TM-E15S26-A1 (6ES7193-4CA40-0AA0)	TM-E15S24-A1 (6ES7193-4CA20-0AA0)	TM-E15S24-01 (6ES7193-4CB20-0AA0)	TM-E15S23-01 (6ES7193-4CB00-0AA0)	← Screw terminal
TM-E15N26-A1 (6ES7193-4CA80-0AA0)	TM-E15N24-A1 (6ES7193-4CA70-0AA0)	TM-E15N24-01 (6ES7193-4CB70-0AA0)	TM-E15N23-01 (6ES7193-4CB60-0AA0)	← Fast Connect
				<p>Wiring examples</p>

Block diagram

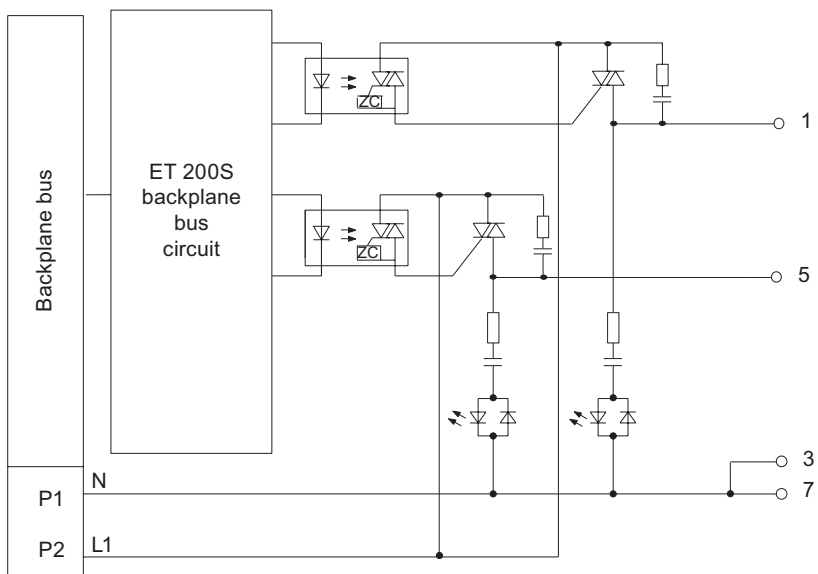

Figure 3-19 Block diagram of the 2DO 24-230 VAC

## 2DO 24 VAC to 230 VAC Technical Specifications (6ES7132-4FB01-0AB0)

Dimensions and Weight	
Dimensions W × H × D (mm) (the total dimensions depend on the selected terminal module)	15 × 81 × 52
Weight	Approx. 37 g
Data for specific modules	
Supports isochronous operation	no
Number of outputs	2
Cable length	
• Unshielded	max. 600 m
• Shielded	max. 1000 m
Parameter length	3 bytes
Voltages, currents, potentials	
Rated load voltage L1 (from the power module)	24 to 230 VAC
• Frequency	47 to 63 Hz
Total current of the outputs (per module)	
• Up to 40° C	max. 2 A <sup>1</sup>
• Up to 60° C	max. 1 A <sup>1</sup>
Galvanic isolation	
• Between the channels	no
• Between the channels and backplane bus	Yes
Insulation tested	2500 VDC
Current consumption	
• From the backplane bus	max. 18 mA
• From rated load voltage L1 (no load)	max. 15 mA per channel
Power dissipation of the module	max. 4 W
Status, interrupts, diagnostics	
Status display	Green LED per channel
Diagnostics function	no
Data for selecting an actuator	
Output voltage	
• At signal "1"	min. L (-1.5 V)
Output current (per channel)	
• At signal "1"	
– Rated value	2 A
– Permitted range	0.1 mA to 2.2 A
• With signal "0" (leakage current)	max. 3 mA
Output delay (for resistive load)	
• at "0" to "1"	max. 15 ms
• At "1" to "0"	max. 15 ms
Zero cross inhibit voltage	max. 25 V

Motor starter size	
• Up to 40° C	Max. size in accordance with NEMA: 5
• Up to 60° C	Max. size in accordance with NEMA: 4
Lamp load	max. 100 W
Connecting two outputs in parallel	
• For redundant triggering of a load	Yes (per module)
• To increase performance	no
Control of a digital input	supported
Switch rate	
• For resistive load	max. 10 Hz
• On inductive load	max. 0.5 Hz
• For lamp load	max. 1 Hz
Short-circuit protection of the output	Yes, by means of fuse in the power module
<sup>1</sup> Total current of the outputs (per module): see the diagram below	

**Total current of the outputs**

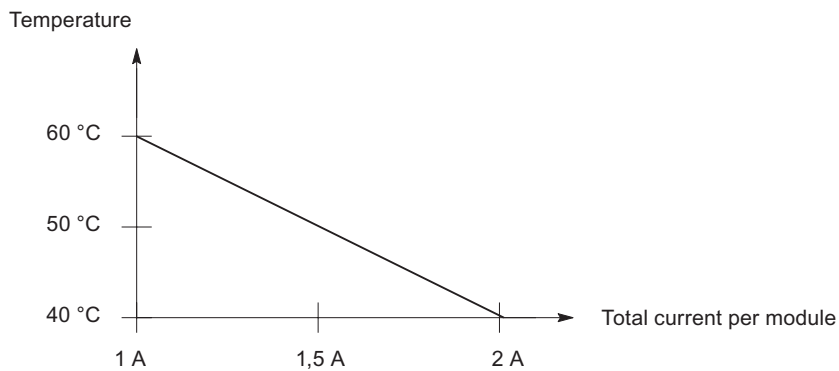

Figure 3-20 Total current of the outputs for 2DO 24 VAC to 230 VAC



### 3.19 2RO NO 24 VDC to 120 VDC/5 A, 24 VDC to 230 VAC/5 A digital electronic module (6ES7132-4HB01-0AB0)

#### Properties

- Digital electronic module with two relay outputs
- Output current 5 A per output
- Rated load voltage DC up to 120 V / AC to 230 V
- suitable for solenoid valves, DC contactors, and indicator lights
- Isolated from the supply voltage



#### Caution

The rated power supply voltage of the 2RO NO 24 VDC to 120 VDC/5 A, 24 VAC to 230 VAC/5 A is 24 VDC. The 2RO NO 24 VDC to 120 VDC/5 A, 24 VAC to 230 VAC/5 A must be in a 24 VDC potential group only (from the power module).

#### General terminal assignment

#### Note

Terminals 4, 8, A4, A8, A3 and A7 are only available at specified terminal modules.

Terminal assignment for 2RO NO 24 VDC to 120 VDC/5 A, 24 VAC to 230 VAC/5 A (6ES7132-4HB01-0AB0)				
Terminal	Assignment	Terminal	Assignment	Notes
1	13	5	23	<ul style="list-style-type: none"> <li>• 13, 14: Normally open contact, channel 0</li> <li>• 23, 24: Normally open contact, channel 1</li> <li>• n.c.: Not connected (max. DC 30 V can be connected)</li> <li>• AUX1: Protective-conductor terminal or potential bus (freely usable up to 230 VAC)</li> </ul>
2	14	6	24	
3	14	7	24	
4	n.c.	8	n.c.	
A4	AUX1	A8	AUX1	
A3	AUX1	A7	AUX1	

Usable terminal modules

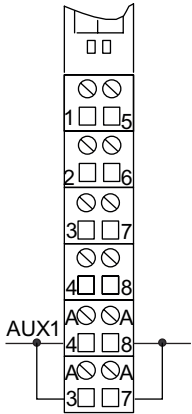
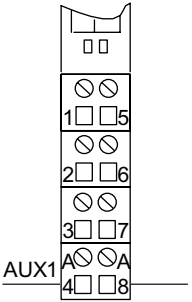
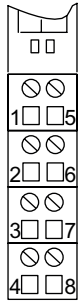
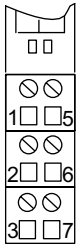
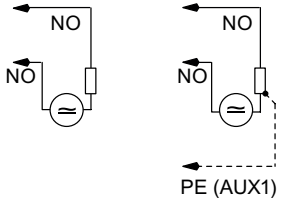
Usable terminal modules for 2RO NO 24 VDC to 120 VDC/5 A, 24 VAC to 230 VAC/5 A (6ES7132-4HB01-0AB0)				
TM-E15C26-A1 (6ES7193-4CA50-0AA0)	TM-E15C24-A1 (6ES7193-4CA30-0AA0)	TM-E15C24-01 (6ES7193-4CB30-0AA0)	TM-E15C23-01 (6ES7193-4CB10-0AA0)	← Spring terminal
TM-E15S26-A1 (6ES7193-4CA40-0AA0)	TM-E15S24-A1 (6ES7193-4CA20-0AA0)	TM-E15S24-01 (6ES7193-4CB20-0AA0)	TM-E15S23-01 (6ES7193-4CB00-0AA0)	← Screw terminal
TM-E15N26-A1 (6ES7193-4CA80-0AA0)	TM-E15N24-A1 (6ES7193-4CA70-0AA0)	TM-E15N24-01 (6ES7193-4CB70-0AA0)	TM-E15N23-01 (6ES7193-4CB60-0AA0)	← Fast Connect
				<p>Wiring examples</p> 

Block diagram

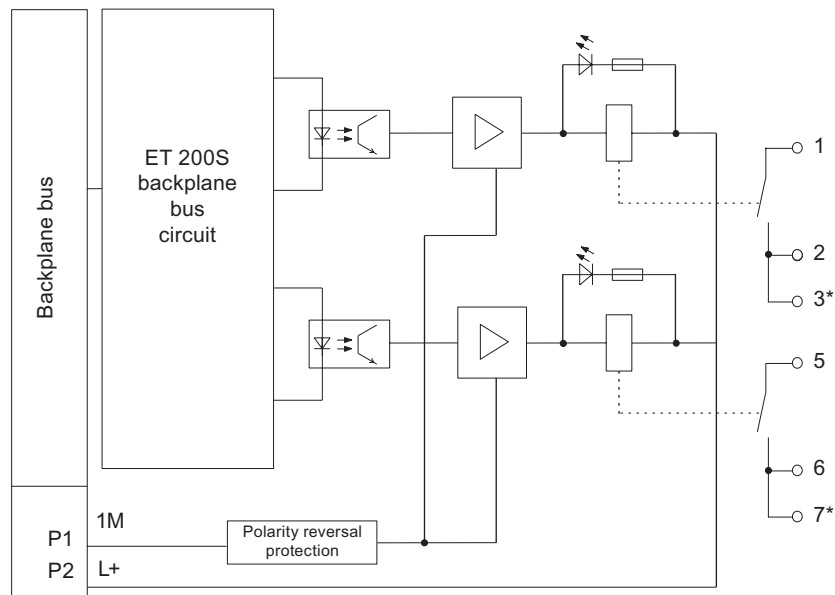

\* From product level 2 of the 2RO NO 24--120 VDC/5 24--230 VAC/5 A the internal bridge between terminals 2 and 6 is not installed. If you require this bridge, it can be replaced by an external bridge between terminals 3 and 7.

Figure 3-21 Block diagram of the 2RO NO 24-120 VDC/5 A, 230 VAC/5 A

Technical Specifications 2RO NO 24 VDC to 120 VDC/5 A, 230 VAC/5 A (6ES7132-4HB01-0AB0)

Dimensions and Weight	
Dimensions W × H × D (mm) (the total dimensions depend on the selected terminal module)	15 × 81 × 52
Weight	Approx. 50 g
Data for specific modules	
Supports isochronous operation	no
Number of outputs	2
Cable length	
• Unshielded	max. 600 m
• Shielded	max. 1000 m
Parameter length	3 bytes
Voltages, currents, potentials	
Rated supply voltage L+ (from the power module)	24 VDC
Reverse polarity protection Current per channel	Yes
• up to 50 °C	max. 5 A
• Up to 60 °C	max. 4 A

3.19 2RO NO 24 VDC to 120 VDC/5 A, 24 VDC to 230 VAC/5 A digital electronic module (6ES7132-4HB01-0AB0)

Galvanic isolation	
• Between the channels	Yes
• Between the channels and backplane bus	Yes
• Between the channels and supply voltage	Yes
• Between the supply voltage and backplane bus	Yes
Permissible potential difference	
• Between the supply voltage and backplane bus	75 VDC / 60 VAC
• Between channels and backplane bus	240 VAC
• Between the channels and supply voltage	240 VAC
Insulation tested	Yes
• Between the supply voltage and backplane bus	500 VDC
• Between channels and backplane bus	1500 VAC
• Between the channels and supply voltage	1500 VAC
Current consumption	
• From the power supply L+	max. 30 mA
Power dissipation of the module	Typically 0.6 W
<b>Status, interrupts, diagnostics</b>	
Status display	Green LED per channel
Diagnostics function	no
<b>Data for selecting an actuator</b>	
Output current	
• Continuous thermal current	max. 5 A
• Min. load current	8 mA
• min. voltage	17 V
Connecting two outputs in parallel	
• For redundant triggering of a load	no
• To increase performance	no
Control of a digital input	Yes
Switch rate	
• For resistive load	2 Hz
• On inductive load	0.5 Hz
• For lamp load	2 Hz
Limitation (internal) of the voltage induced on circuit interruption	no
Short-circuit protection of the output <sup>1</sup>	no
<sup>1</sup> The relay outputs must be fused externally with 6 A.	

**Switching capacity and lifetime of the contacts**

With an external protective circuit, the contacts will last longer than specified in the table. This table shows the switching capacity and endurance of the relay contacts:

Table 3-5 Switching capacity and lifetime of the relay contacts

Resistive load	Voltage	Current	Operating cycles (typical)
For resistive load	24 VDC	5.0 A	0.1 million
		4.0 A	0.2 million
		2.0 A	0.5 million
		1.0 A	1.6 million
		0.5 A	4 million
		0.1A	7 million
	60 VDC	0.5 A	1.6 million
	120 VDC	0.2 A	1.6 million
	48 VAC	2.0 A	1.6 million
	60 VAC	2.0 A	1.2 million
	120 VAC	5.0 A	0.1 million
		3.0 A	0.2 million
		2.0 A	0.4 million
		1.0 A	0.8 million
		0.5 A	1.5 million
	230 VAC	5.0 A	0.1 million
		3.0 A	0.2 million
		2.0 A	0.4 million
		1.0 A	0.8 million
		0.5 A	1.5 million
For inductive load in accordance with IEC 947-5-1 DC 13/ AC 15	24 VDC	2.0 A	0.1 million
		1.0 A	0.2 million
		0.5 A	0.5 million
	60 VDC	0.5 A	0.2 million
	120 VDC	0.2 A	0.5 million
	48 VAC	1.0 A	0.7 million
	60 VAC	1.0 A	0.5 million
	120 VAC	2.0 A	0.1 million
		1.0 A	0.3 million
		0.5 A	1 million
0.1A		2 million	
For inductive load in accordance with IEC 947-5-1 DC 13/ AC 15	230 VAC	2.0 A	0.1 million
		1.0 A	0.3 million
		0.5 A	1 million

### 3.20 2RO NO/NC 24 VDC to 48 VDC/5 A, 24 VAC to 230 VAC/5 A digital electronic module (6ES7132-4HB11-0AB0)

#### Properties

- Digital electronic module with two relay outputs
- Output current 5 A per output
- Replacement value
- Suitable for solenoid valves, DC contactors, and indicator lights
- Isolated from the supply voltage
- NO and NC contact

---

#### Note

If you connect an extra-low voltage system (SELV/PELF) on one channel of the relay subassembly, you can only use an extra-low voltage system (SELV/PELF) on the other channel.

---

#### General terminal assignment

---

#### Note

Terminals 4, 8, A4, A8, A3 and A7 are only available at specified terminal modules.

---

Terminal assignment for 2RO NO/NC 24 VDC to 48 VDC/5 A, 24 VAC to 230 VAC/5 A (6ES7132-4HB11-0AB0)				
Terminal	Assignment	Terminal	Assignment	Notes
1	Common <sub>0</sub>	5	Common <sub>1</sub>	<ul style="list-style-type: none"> <li>• Common<sub>n</sub>, NOC<sub>n</sub> or NCC<sub>n</sub>, channel n</li> <li>• N: Neutral conductor</li> <li>• n.c.: Not connected (max. DC 30 V can be connected)</li> <li>• AUX1: Protective-conductor terminal or potential bus (freely usable up to 230 VAC)</li> </ul>
2	Normally open contact <sub>0</sub>	6	Normally open contact <sub>1</sub>	
3	Normally closed contact <sub>0</sub>	7	Normally closed contact <sub>1</sub>	
4	n.c.	8	n.c.	
A4	AUX1	A8	AUX1	
A3	AUX1	A7	AUX1	

3.20 2RO NO/NC 24 VDC to 48 VDC/5 A, 24 VAC to 230 VAC/5 A digital electronic module (6ES7132-4HB11-0AB0)

Usable terminal modules

Usable terminal modules for 2RO NO/NC 24 VDC to 48 VDC/5 A, 24 VAC to 230 VAC/5 A (6ES7132-4HB11-0AB0)				
TM-E15C26-A1 (6ES7193-4CA50-0AA0)	TM-E15C24-A1 (6ES7193-4CA30-0AA0)	TM-E15C24-01 (6ES7193-4CB30-0AA0)	TM-E15C23-01 (6ES7193-4CB10-0AA0)	← Spring terminal
TM-E15S26-A1 (6ES7193-4CA40-0AA0)	TM-E15S24-A1 (6ES7193-4CA20-0AA0)	TM-E15S24-01 (6ES7193-4CB20-0AA0)	TM-E15S23-01 (6ES7193-4CB00-0AA0)	← Screw terminal
TM-E15N26-A1 (6ES7193-4CA80-0AA0)	TM-E15N24-A1 (6ES7193-4CA70-0AA0)	TM-E15N24-01 (6ES7193-4CB70-0AA0)	TM-E15N23-01 (6ES7193-4CB60-0AA0)	← Fast Connect
				<p>Wiring examples</p>

Block diagram

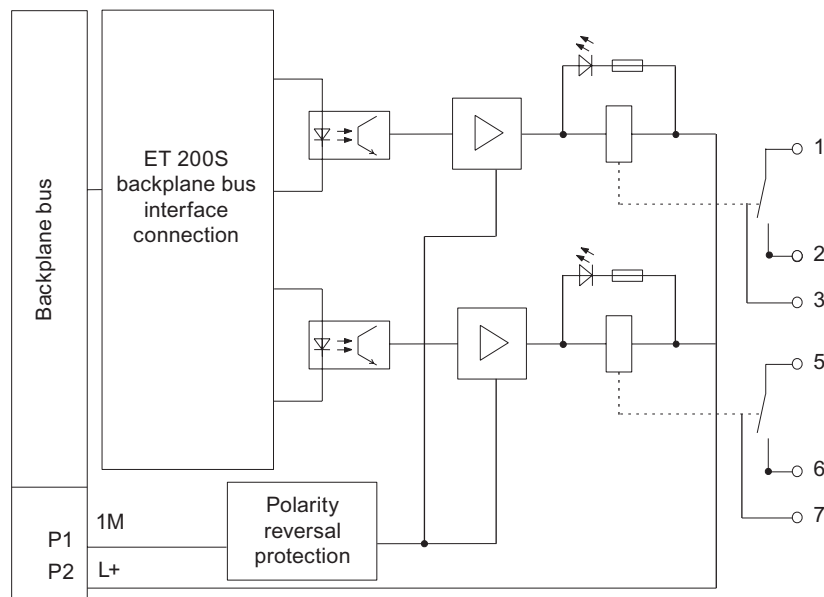

Figure 3-22 Block diagram of the 2RO NO/NC 24 VDC to 48 VDC/5 A 24 VAC to 230 VAC/5 A

**2RO NO/NC 24 VDC to 48 VDC/5 A, 24 VAC to 230 VAC/5 A Technical Specifications (6ES7132-4HB11-0AB0)**

<b>Dimensions and Weight</b>	
Dimensions W × H × D (the total dimensions depend on the selected terminal module)	15 × 81 × 52 (mm)
Weight	Approx. 50 g
<b>Data for specific modules</b>	
Supports isochronous operation	no
Number of outputs	2
Cable length	
• Unshielded	max. 600 m
• Shielded	max. 1000 m
Parameter length	3 bytes
<b>Voltages, currents, potentials</b>	
Rated supply voltage L+ (from the power module)	24 VDC
Reverse polarity protection Current per channel	Yes
• up to 50 °C	max. 5 A
• Up to 60 °C	max. 4 A
Galvanic isolation	
• Between the channels	Yes
• Between channels and backplane bus	Yes
• Between the channels and supply voltage	Yes
• Between the supply voltage and backplane bus	Yes
Permissible potential difference	
• Between the supply voltage and backplane bus	75 VDC / 60 VAC
• Between channels and backplane bus	240 VAC
• Between the channels and supply voltage	240 VAC
Insulation tested	
• Between the supply voltage and backplane bus	500 VDC
• Between channels and backplane bus	2500 VDC
• Between the channels and supply voltage	2500 VDC
Current consumption	
• From the power supply L+	max. 30 mA
• From the backplane bus	max. 10 mA
Power dissipation of the module	Typically 0.6 W
<b>Status, interrupts, diagnostics</b>	
Status display	Green LED per channel
Diagnostics function	no



Data for selecting an actuator	
Output current	
• Continuous thermal current	max. 5 A
• Min. load current	8 mA
Connecting two outputs in parallel	
• for redundant triggering of a load	no
• To increase performance	no
Control of a digital input	Yes
Switch rate	
• For resistive load	2 Hz
• On inductive load	0.5 Hz
• For lamp load	2 Hz
Limitation (internal) of the voltage induced on circuit interruption	no
Short-circuit protection of the output <sup>1</sup>	no
<sup>1</sup> The relay outputs must be fused externally with 6 A. For installation in a hazardous area as specified by the National Electric Code (NEC) the fuse must only be removed with a suitable tool if the subassembly is not in an explosive area.	

**Switching capacity and lifetime of the contacts**

With an external protective circuit, the contacts will last longer than specified in the table.

The normally open and normally closed contacts of the relay have a different lifetime. The table shows the switching capacity and lifetime of the contacts.

Table 3-6 Switching capacity and lifetime of the contacts

Resistive load	Voltage	Current	Duty cycles (typ.) Normally closed contact	Duty cycles (typ.) Normally open contact
For resistive load	24 VDC	5.0 A	0.1 million	0.15 million
		4.0 A	0.2 million	0.175 million
		2.0 A	0.45 million	0.3 million
		0.5 A	1.4 million	1.1 million
		0.1A	1.5 million	1.5 million
	48 VDC	2.0 A	0.15 million	0.11 million
		1.0 A	0.3 million	0.2 million
		0.5 A	0.6 million	0.6 million
		0.1A	0.8 million	0.6 million
	48 VAC	2.0 A	0.45 million	0.35 million
	60 VAC	2.0 A	0.45 million	0.35 million
	120 VAC	5.0 A	0.1 million	0.1 million
		3.0 A	0.2 million	0.2 million
		2.0 A	0.4 million	0.3 million
		1.0 A	0.8 million	0.6 million
		0.5 A	1.5 million	1.0 million
	230 VAC	5.0 A	0.1 million	0.1 million
		3.0 A	0.2 million	0.2 million
		2.0 A	0.4 million	0.3 million
		1.0 A	0.8 million	0.6 million
0.5 A		1.5 million	1.0 million	
For inductive load in accordance with IEC 947-5-1 DC 13/ AC 15	24 VDC	2.0 A	0.1 million	0.1 million
		1.0 A	0.2 million	0.2 million
		0.5 A	0.5 million	0.5 million
	48 VDC	2.0 A	0.07 million	0.05 million
		1.0 A	0.15 million	0.1 million
		0.5 A	0.4 million	0.25 million
For inductive load in accordance with IEC 947-5-1 DC 13/ AC 15	48 VAC	1.0 A	0.5 million	0.3 million
	60 VAC	1.0 A	0.5 million	0.3 million
	120 VAC	2.0 A	0.1 million	0.1 million
		1.0 A	0.3 million	0.1 million
		0.5 A	0.9 million	0.6 million
	230 VAC	0.1 A	1.5 million	1.0 million
		2.0 A	0.1 million	0.1 million
		1.0 A	0.5 million	0.3 million
		0.5 A	0.9 million	0.6 million
		0.1 A	1.0 million	1.0 million

## Analog electronic modules

### 4.1 Introduction

#### Range of analog electronic modules

The range of analog electronic modules (EM) includes modules for measurement of voltage and current. HIGH SPEED modules can be used for time-critical measurement of voltage and current. HIGH FEATURE modules have a high resolution and precision.

Modules for connection of thermocouples and resistance thermometers or resistors are also available.

The range also includes modules for connecting loads and actuators to current and voltage outputs.

### 4.2 Analog value representation

#### 4.2.1 Overview

##### Electronic modules with analog inputs

With the electronics module with analog inputs, continuously variable signals, such as those occurring in temperature measurement and pressure measurement, can be acquired, evaluated, and converted to digital values for further processing.

##### Electronic modules with analog outputs

With the electronics modules with analog outputs, digital values set by a controller can be converted to a corresponding analog signal (current) in an analog output module and used to control suitable actuators (setpoint input for speed controllers, temperature controllers and similar).

### Measured Values in the Event of Wire Break Dependent on Enabled Diagnostics

For the measuring range tables

- 1 V to 5 V, 4 mA to 20 mA
- Temperature sensor Pt xxx Standard and Climatic, Ni xx Standard and Climatic, Cu 10 Standard and Climatic
- Thermocouple type E, N, J, K, L, S, R, B, C, T

the following supplements and rules apply:

Table 4-1 Measured Values in the Event of Wire Break Dependent on Enabled Diagnostics

Format	Parameter assignment	Measured values		Description
		Decimal	Hexadecimal	
S7	• Enable "wire break" diagnosis (at 1 V to 5 V, 4 mA to 20 mA, RTD) <sup>1</sup>	32767	7FFF <sub>H</sub>	• Diagnostics message "wire break"
	• Enable "wire break test" diagnostics (with TC)	32767	7FFF <sub>H</sub>	• Diagnostics message "wire break"
	• "Wire break" diagnostics disabled (at 1 to 5 V, 4 to 20 mA, RTD) <sup>1</sup> • "Overflow/underflow" diagnostics enabled	-32767	8000 <sub>H</sub>	• Measured value after leaving the undershoot range • "Value under low limit" diagnostic message
	• "Wire break" diagnostics disabled (at 1 to 5 V, 4 to 20 mA, RTD) <sup>1</sup> • "Overflow/underflow" diagnostics disabled	-32767	8000 <sub>H</sub>	• Measured value after leaving the undershoot range
	• "Wire break test" diagnostics disabled (with TC)	---	---	• Open input: Undefined measured value

<sup>1</sup> Measured value limits for wire-break and undershoot detection:  
 1 to 5 V: at 0.296 V  
 4 mA to 20 mA: at 1.185 mA

### 4.2.2 Analog Value Representation for Measuring Ranges with SIMATIC S7

#### Analog value representation

With the same nominal range, the digitized analog value is the same for input and output values. Analog values are represented in two's complement.

The following table shows the analog value representation of the analog electronics modules.

Table 4-2 Analog Value Representation (SIMATIC S7 Format)

Resolution	Analog Value															
Bit number	15	14	13	12	11	10	9	8	7	6	5	4	3	2	1	0
Significance of the bits	S	2 <sup>14</sup>	2 <sup>13</sup>	2 <sup>12</sup>	2 <sup>11</sup>	2 <sup>10</sup>	2 <sup>9</sup>	2 <sup>8</sup>	2 <sup>7</sup>	2 <sup>6</sup>	2 <sup>5</sup>	2 <sup>4</sup>	2 <sup>3</sup>	2 <sup>2</sup>	2 <sup>1</sup>	2 <sup>0</sup>

## Sign

The sign (S) of the analog value is always in bit number 15:

- "0" → +
- "1" → –

## Measurement resolution

The following table shows the representation of the binary analog values and the corresponding decimal and hexadecimal representation of the units of the analog values.

The table shows the resolutions 11, 12, 13, and 15 bit + sign. Each analog value is entered left aligned in the ACCU. The bits marked with "x" are set to "0".

Table 4-3 Measured Value Resolution of the Analog Values (SIMATIC S7 Format)

Resolution in Bits	Units		Analog Value	
	Decimal	Hexadecimal	High byte	Low byte
11+S	16	10 <sub>H</sub>	S 0 0 0 0 0 0 0	0 0 1 x x x x
12+S	8	8 <sub>H</sub>	S 0 0 0 0 0 0 0	0 0 0 1 x x x
13+S	4	4 <sub>H</sub>	S 0 0 0 0 0 0 0	0 0 0 0 1 x x
15 + sign	1	1 <sub>H</sub>	S 0 0 0 0 0 0 0	0 0 0 0 0 0 1

---

### Note

This resolution does not apply to temperature values. The converted temperature values are the result of a conversion in the analog electronics module.

---



---

### Note

The following applies with temperature measurements: When leaving the linearized nominal range, the existing gradient of the characteristic curve is retained in the overflow and underflow range.

---

### 4.2.3 Measuring ranges of the analog input modules in SIMATIC S7 format for voltage, current and resistance-type sensors

#### Introduction

The following tables contain the digitized analog values for the measuring ranges of the analog input modules.

Since the binary representation of the analog values is always the same, these tables contain only a comparison of the measuring ranges with the units.

#### Voltage measuring ranges: $\pm 80$ mV, $\pm 2.5$ V, $\pm 5$ V, $\pm 10$ V

Table 4-4 SIMATIC S7 format: measuring ranges  $\pm 80$  mV,  $\pm 2.5$  V,  $\pm 5$  V and  $\pm 10$  V

Measuring range $\pm 80$ mV	Measuring range $\pm 2.5$ V	Measuring range $\pm 5$ V	Measuring range $\pm 10$ V	Units		Range
				Decimal	Hexadecimal	
> 94.071	> 2.9397	> 5.8794	> 11.7589	32767	7FFF <sub>H</sub>	Overflow
94.071	2.9397	5.8794	11.7589	32511	7EFF <sub>H</sub>	Overshoot range
:	:	:	:	:	:	
80.003	2.5001	5.0002	10.0004	27649	6C01 <sub>H</sub>	
80.000	2.5	5.00	10.00	27648	6C00 <sub>H</sub>	Rated range
60.000	1.86	3.75	7.50	20736	5100 <sub>H</sub>	
:	:	:	:	:	:	
-60.000	-1.86	-3.75	-7.50	-20736	AF00 <sub>H</sub>	
-80.000	-2.50	-5.00	-10.00	-27648	9400 <sub>H</sub>	
-80.003	-2.5001	-5.0002	-10.0004	-27649	93FF <sub>H</sub>	Undershoot range
:	:	:	:	:	:	
-94.074	-2.9397	-5.8796	-11.759	-32512	8100 <sub>H</sub>	
< -94.074	< -2.9397	< -5.8796	< -11.759	-32768	8000 <sub>H</sub>	Underflow

**Measuring ranges for voltage and current: 1 V to 5 V, 0 mA to 20 mA, 4 mA to 20 mA**

Table 4-5 SIMATIC S7 format: measuring ranges 1 V to 5 V, 0 mA to 20 mA, 4 mA to 20 mA

Measuring range 1 mA to 5 mA	Measuring range 0 mA to 20 mA	Measuring range 4 mA to 20 mA	Units		Range
			Decimal	Hexadecimal	
> 5.704	> 23.5178	> 22.8142	32767	7FFF <sub>H</sub>	Overflow
5.704	23.5178	22.8142	32511	7EFF <sub>H</sub>	Overshoot range
:	:	:	:	:	
5.000145	20.0007	20.0005	27649	6C01 <sub>H</sub>	
5.000	20.0000	20.0000	27648	6C00 <sub>H</sub>	Rated range
4.000	15.0000	16.0000	20736	5100 <sub>H</sub>	
:	:	:	:	:	
1.000	0.0000	4.0000	0	0 <sub>H</sub>	
0.999855	Negative values are not supported	3.9995	-1	FFFF <sub>H</sub>	Undershoot range
:		.	:	:	
0.296		1.1852	-4864	ED00 <sub>H</sub>	
< 0.296		< 1.1852	-32768	8000 <sub>H</sub>	Underflow

**Current measuring range: ± 20 mA**

Table 4-6 SIMATIC S7 format: Measuring range ± 20 mA

Measuring range ± 20 mA	Units		Range
	Decimal	Hexadecimal	
> 23.5150	32767	7FFF <sub>H</sub>	Overflow
23.5150	32511	7EFF <sub>H</sub>	Overshoot range
:	:	:	
20.0007	27649	6C01 <sub>H</sub>	
20.0000	27648	6C00 <sub>H</sub>	Rated range
14.9980	20736	5100 <sub>H</sub>	
:	:	:	
-14.9980	-20736	AF00 <sub>H</sub>	
-20.0000	-27648	9400 <sub>H</sub>	
-20.0007	-27649	93FF <sub>H</sub>	Undershoot range
:	:	:	
-23.5160	-32512	8100 <sub>H</sub>	
< -23.5160	-32768	8000 <sub>H</sub>	Underflow

**Measuring ranges for resistive sensors: 150 Ω, 300 Ω, 600 Ω, 3000 Ω**

Table 4-7 SIMATIC S7 format: Measuring ranges 150 Ω, 300 Ω, 600 Ω, 3000 Ω

Measuring range 150 Ω	Measuring range 300 Ω	Measuring range 600 Ω	Measuring range 3000 Ω	Units		Range
				Decimal	Hexadecimal	
> 176.38	> 352.77	> 705.53	> 3527.67	32767	7FFF <sub>H</sub>	Overflow
176.38	352.77	705.53	3527.67	32511	7EFF <sub>H</sub>	Overshoot range
:	:	:	:	:	:	
150.005	300.01	600.02	3000.11	27649	6C01 <sub>H</sub>	
150.00	300.00	600.00	3000.00	27648	6C00 <sub>H</sub>	Rated range
112.50	225.00	450.00	2250.00	20736	5100 <sub>H</sub>	
:	:	:	:	:	:	
0.00	0.00	0.00	0.00	0	0 <sub>H</sub>	
(negative values are not physically possible)				-1	FFFF <sub>H</sub>	Undershoot range <sup>1</sup>
				:	:	
				-4864	ED00 <sub>H</sub>	
				-32768	8000 <sub>H</sub>	Underflow <sup>1</sup>

<sup>1</sup> With faulty connection of resistors

**4.2.4 Measuring Range of the Analog Input Modules in SIMATIC S7 Format for Resistance Thermometers**

**Measuring ranges for resistance thermometer Pt x00 Standard**

Table 4-8 SIMATIC S7 format: Measuring ranges Pt 100, 200, 500, 1000 Standard in °C and °F

Pt x00 Standard in °C (1 digit = 0.1 °C)	Units		Pt x00 Standard in °F (1 digit = 0.1 °F)	Units		Range
	Decimal	Hexadecimal		Decimal	Hexadecimal	
> 1000.0	32767	7FFF <sub>H</sub>	> 1832.0	32767	7FFF <sub>H</sub>	Overflow
1000.0	10000	2710 <sub>H</sub>	1832.0	18320	4790 <sub>H</sub>	Overshoot range
:	:	:	:	:	:	
850.1	8501	2135 <sub>H</sub>	1562.1	15621	3D05 <sub>H</sub>	
850.0	8500	2134 <sub>H</sub>	1562.0	15620	3D04 <sub>H</sub>	Rated range
:	:	:	:	:	:	
-200.0	-2000	F830 <sub>H</sub>	-328.0	-3280	F330 <sub>H</sub>	
-200.1	-2001	F82F <sub>H</sub>	-328.1	-3281	F32F <sub>H</sub>	Undershoot range
:	:	:	:	:	:	
-243.0	-2430	F682 <sub>H</sub>	-405.4	-4054	F02A <sub>H</sub>	
< -243.0	-32768	8000 <sub>H</sub>	< -405.4	-32768	8000 <sub>H</sub>	Underflow



### Measuring ranges for resistance thermometer Pt x00 Climatic

Table 4-9 SIMATIC S7 format: Measuring ranges Pt 100, 200, 500, 1000 Climatic in °C and °F

Pt x00 Climatic in °C (1 digit = 0.01 °C)	Units		Pt x00 Climatic in °F (1 digit = 0.01 °F)	Units		Range
	Decimal	Hexadecimal		Decimal	Hexadecimal	
> 155.00	32767	7FFF <sub>H</sub>	> 311.00	32767	7FFF <sub>H</sub>	Overflow
155.00	15500	3C8C <sub>H</sub>	311.00	31100	797C <sub>H</sub>	Overshoot range
:	:	:	:	:	:	
130.01	13001	32C9 <sub>H</sub>	266.01	26601	E9 <sub>H</sub>	Rated range
130.00	13000	32C8 <sub>H</sub>	266.00	26600	E8 <sub>H</sub>	
:	:	:	:	:	:	Undershoot range
-120.00	-12000	D120 <sub>H</sub>	-184.00	-18400	B820 <sub>H</sub>	
-120.01	-12001	D11F <sub>H</sub>	-184.01	-18401	B81F <sub>H</sub>	Undershoot range
:	:	:	:	:	:	
-145.00	-14500	C75C <sub>H</sub>	-229.00	-22900	A68C <sub>H</sub>	Underflow
< -145.00	-32768	8000 <sub>H</sub>	< -229.00	-32768	8000 <sub>H</sub>	

### Measuring ranges for resistance thermometer Ni x00 Standard

Table 4-10 SIMATIC S7 format: Measuring ranges Ni 100, 120, 200, 500, 1000 Standard in °C and °F

Ni x00 Standard in °C (1 digit = 0.1 °C)	Units		Ni x00 Standard in °F (1 digit = 0.1 °F)	Units		Range
	Decimal	Hexadecimal		Decimal	Hexadecimal	
> 295.0	32767	7FFF <sub>H</sub>	> 563.0	32767	7FFF <sub>H</sub>	Overflow
295.0	2950	B86 <sub>H</sub>	563.0	5630	15FE <sub>H</sub>	Overshoot range
:	:	:	:	:	:	
250.1	2501	9C5 <sub>H</sub>	482.1	4821	12D5 <sub>H</sub>	Rated range
250.0	2500	9C4 <sub>H</sub>	482.0	4820	12D4 <sub>H</sub>	
:	:	:	:	:	:	Undershoot range
-60.0	-600	FDA8 <sub>H</sub>	-76.0	-760	FD08 <sub>H</sub>	
-60.1	-601	FDA7 <sub>H</sub>	-76.1	-761	FD07 <sub>H</sub>	Undershoot range
:	:	:	:	:	:	
-105.0	-1050	FBE6 <sub>H</sub>	-157.0	-1570	F9DE <sub>H</sub>	Underflow
< -105.0	-32768	8000 <sub>H</sub>	< -157.0	-32768	8000 <sub>H</sub>	

### Measuring ranges for resistance thermometer Ni x00 Climatic

Table 4-11 SIMATIC S7 format: Measuring ranges Ni 100, 120, 200, 500, 1000 Climatic in °C and °F

Ni x00 Climatic in °C (1 digit = 0.01 °C)	Units		Ni x00 Climatic in °F (1 digit = 0.01 °F)	Units		Range
	Decimal	Hexadecimal		Decimal	Hexadecimal	
> 295.00	32767	7FFF <sub>H</sub>	> 325.11	32767	7FFF <sub>H</sub>	Overflow
295.00	29500	733C <sub>H</sub>	327.66	32766	7FFE <sub>H</sub>	Overshoot range
:	:	:	:	:	:	
250.01	25001	61A9 <sub>H</sub>	280.01	28001	6D61 <sub>H</sub>	Rated range
250.00	25000	61A8 <sub>H</sub>	280.00	28000	6D60 <sub>H</sub>	
:	:	:	:	:	:	Undershoot range
-60.00	-6000	E890 <sub>H</sub>	-76.00	-7600	E250 <sub>H</sub>	
-60.01	-6001	E88F <sub>H</sub>	-76.01	-7601	E24F <sub>H</sub>	Underflow
:	:	:	:	:	:	
-105.00	-10500	D6FC <sub>H</sub>	-157.00	-15700	C2AC <sub>H</sub>	
< -105.00	-32768	8000 <sub>H</sub>	< -157.00	-32768	8000 <sub>H</sub>	

### Measuring ranges for resistance thermometer Cu 10 Standard

Table 4-12 SIMATIC S7 format: Measuring ranges Cu 10 Standard in °C and °F

Cu 10 Standard in °C (1 digit = 0.1 °C)	Units		Cu 10 Standard in °F (1 digit = 0.1 °F)	Units		Range
	Decimal	Hexadecimal		Decimal	Hexadecimal	
> 312.0	32767	7FFF <sub>H</sub>	> 593.6	32767	7FFF <sub>H</sub>	Overflow
312.0	3120	C30 <sub>H</sub>	593.6	5936	1730 <sub>H</sub>	Overshoot range
:	:	:	:	:	:	
260.1	2601	A29 <sub>H</sub>	500.1	5001	12D5 <sub>H</sub>	Rated range
260.0	2600	A28 <sub>H</sub>	500.0	5000	1389 <sub>H</sub>	
:	:	:	:	:	:	Undershoot range
-200.0	-2000	F830 <sub>H</sub>	-328.0	-3280	F330 <sub>H</sub>	
-200.1	-2001	F82F <sub>H</sub>	-328.1	-3281	F32F <sub>H</sub>	Underflow
:	:	:	:	:	:	
-240.0	-2400	F6A0 <sub>H</sub>	-400.0	-4000	F060 <sub>H</sub>	
< -240.0	-32768	8000 <sub>H</sub>	< -400.0	-32768	8000 <sub>H</sub>	

### Measuring ranges for resistance thermometer Cu 10 Climatic

Table 4-13 SIMATIC S7 format: Measuring ranges Cu 10 Climatic in °C and °F

Cu 10 Climatic in °C (1 digit = 0.01 °C)	Units		Cu 10 Climatic in °F (1 digit = 0.01° F)	Units		Range
	Decimal	Hexadecimal		Decimal	Hexadecimal	
> 180.00	32767	7FFF <sub>H</sub>	> 325.11	32767	7FFF <sub>H</sub>	Overflow
180.00	18000	H	327.66	32766	7FFE <sub>H</sub>	Overshoot range
:	:	:	:	:	:	
150.01	15001	3A99 <sub>H</sub>	280.01	28001	6D61A <sub>H</sub>	Rated range
150.00	15000	3A98 <sub>H</sub>	280.00	28000	6D60 <sub>H</sub>	
:	:	:	:	:	:	Undershoot range
-50.00	-5000	EC78 <sub>H</sub>	-58.00	-5800	E958 <sub>H</sub>	
-50.01	-5001	EC77 <sub>H</sub>	-58.01	-5801	E957 <sub>H</sub>	Underflow
:	:	:	:	:	:	
-60.00	-6000	E890 <sub>H</sub>	-76.00	-7600	E250 <sub>H</sub>	
< -60.00	-32768	8000 <sub>H</sub>	< -76.00	-32768	8000 <sub>H</sub>	

### 4.2.5 Measuring Range of the Analog Input Modules in SIMATIC S7 Format for Thermocouples

#### Measuring range for thermocouple: Type B

Table 4-14 SIMATIC S7 format: Measuring range Type B in °C and °F

Type B in °C	Units		Type B in °F	Units		Range
	Decimal	Hexadecimal		Decimal	Hexadecimal	
> 2070.0	32767	7FFF <sub>H</sub>	> 3276.6	32767	7FFF <sub>H</sub>	Overflow
2070.0	20700	50DC <sub>H</sub>	3276.6	32766	7FFE <sub>H</sub>	Overshoot range
:	:	:	:	:	:	
1820.1	18201	4719 <sub>H</sub>	2786.6	27866	6CDA <sub>H</sub>	Rated range
1820.0	18200	4718 <sub>H</sub>	2786.5	27865	6CD9 <sub>H</sub>	
:	:	:	:	:	:	Undershoot range
0.0	0	0000 <sub>H</sub>	32	320	0140 <sub>H</sub>	
-0.1	-1	FFFF <sub>H</sub>	31.9	319	013F <sub>H</sub>	Underflow
:	:	:	:	:	:	
-120.0	-1200	FB50 <sub>H</sub>	-184.0	-1840	F8D0 <sub>H</sub>	
< -120.0	-32768	8000 <sub>H</sub>	< -184.0	-32768	8000 <sub>H</sub>	

**Measuring range for thermocouple: Type C**

Table 4-15 SIMATIC S7 format: Measuring range Type C in °C and °F

Type C in °C	Units		Type C in °F	Units		Range
	Decimal	Hexadecimal		Decimal	Hexadecimal	
> 2500.0	32767	7FFF <sub>H</sub>	> 3276.6	32767	7FFF <sub>H</sub>	Overflow
2500.0	25000	61A8 <sub>H</sub>	3276.6	32766	7FFE <sub>H</sub>	Overshoot range
:	:	:	:	:	:	
2315.1	23151	5A6F <sub>H</sub>	2786.6	27866	6CDA <sub>H</sub>	Rated range
2315.0	23150	5A6E <sub>H</sub>	2786.5	27865	6CD9 <sub>H</sub>	
:	:	:	:	:	:	Undershoot range
0.0	0	0000 <sub>H</sub>	32.0	320	0140 <sub>H</sub>	
0.1	-1	FFFF <sub>H</sub>	31.9	319	013F <sub>H</sub>	Undershoot range
:	:	:	:	:	:	
-120.0	-1200	FB50 <sub>H</sub>	-184.0	-1840	F8D0 <sub>H</sub>	Underflow
< -120.0	-32768	8000 <sub>H</sub>	< -184.0	-32768	8000 <sub>H</sub>	

**Measuring range for thermocouple type E**

Table 4-16 SIMATIC S7 format: Measuring range Type E in °C and °F

Type E in °C	Units		Type E in °F	Units		Range
	Decimal	Hexadecimal		Decimal	Hexadecimal	
> 1200.0	32767	7FFF <sub>H</sub>	> 2192.0	32767	7FFF <sub>H</sub>	Overflow
1200.0	12000	2EE0 <sub>H</sub>	2192.0	21920	55A0 <sub>H</sub>	Overshoot range
:	:	:	:	:	:	
1000.1	10001	2711 <sub>H</sub>	1832.1	18321	4791 <sub>H</sub>	Rated range
1000.0	10000	2710 <sub>H</sub>	1832.0	18320	4790 <sub>H</sub>	
:	:	:	:	:	:	Underflow
-270.0	-2700	F574 <sub>H</sub>	-454.0	-4540	EE44 <sub>H</sub>	
< -270.0	- 32768	8000 <sub>H</sub>	< -454.0	- 32768	8000 <sub>H</sub>	

### Measuring range for thermocouple type J

Table 4-17 SIMATIC S7 format: Measuring range Type J in °C and °F

Type J in °C	Units		Type J in °F	Units		Range
	Decimal	Hexadecimal		Decimal	Hexadecimal	
> 1450.0	32767	7FFF <sub>H</sub>	> 2642.0	32767	7FFF <sub>H</sub>	Overflow
1450.0	14500	38A4 <sub>H</sub>	2642.0	26420	6734 <sub>H</sub>	Overshoot range
:	:	:	:	:	:	
1200.1	12010	2EEA <sub>H</sub>	2192.1	21921	55A1 <sub>H</sub>	Rated range
1200.0	12000	2EE0 <sub>H</sub>	2192.0	21920	55A0 <sub>H</sub>	
:	:	:	:	:	:	Underflow
-210.0	-2100	F7CC <sub>H</sub>	-346.0	-3460	F27C <sub>H</sub>	
< -210.0	- 32768	8000 <sub>H</sub>	< -346.0	- 32768	8000 <sub>H</sub>	

### Measuring range for thermocouple type K

Table 4-18 SIMATIC S7 format: Measuring range Type K in °C and °F

Type K in °C	Units		Type K in °F	Units		Range
	Decimal	Hexadecimal		Decimal	Hexadecimal	
> 1622.0	32767	7FFF <sub>H</sub>	> 2951.6	32767	7FFF <sub>H</sub>	Overflow
1622.0	16220	3F5C <sub>H</sub>	2951.6	29516	734C <sub>H</sub>	Overshoot range
:	:	:	:	:	:	
1372.1	13721	3599 <sub>H</sub>	2501.7	25062	61B9 <sub>H</sub>	Rated range
1372.0	13720	3589 <sub>H</sub>	2501.6	25061	61B8 <sub>H</sub>	
:	:	:	:	:	:	Underflow
-270.0	-2700	F574 <sub>H</sub>	-454.0	-4540	EE44 <sub>H</sub>	
< -270.0	- 32768	8000 <sub>H</sub>	< -454.0	- 32768	8000 <sub>H</sub>	

### Measuring range for thermocouple type L

Table 4-19 SIMATIC S7 format: Measuring range Type L in °C and °F

Type L in °C	Units		Type L in °F	Units		Range
	Decimal	Hexadecimal		Decimal	Hexadecimal	
> 1150.0	32767	7FFF <sub>H</sub>	> 2102.0	32767	7FFF <sub>H</sub>	Overflow
1150.0	11500	2CEC <sub>H</sub>	2102.0	21020	521C <sub>H</sub>	Overshoot range
:	:	:	:	:	:	
900.1	9001	2329 <sub>H</sub>	1652.1	16521	4089 <sub>H</sub>	Rated range
900.0	9000	2328 <sub>H</sub>	1652.0	16520	4088 <sub>H</sub>	
:	:	:	:	:	:	Underflow
-200.0	-2000	F830 <sub>H</sub>	-328.0	-3280	F330 <sub>H</sub>	
< -200.0	-32768	8000 <sub>H</sub>	< -328.0	-32768	8000 <sub>H</sub>	

### Measuring range for thermocouple type N

Table 4-20 SIMATIC S7 format: Measuring range Type N in °C and °F

Type N in °C	Units		Type N in °F	Units		Range
	Decimal	Hexadecimal		Decimal	Hexadecimal	
> 1550.0	32767	7FFF <sub>H</sub>	> 2822.0	32767	7FFF <sub>H</sub>	Overflow
1550.0	15500	3C8C <sub>H</sub>	2822.0	28220	6E3C <sub>H</sub>	Overshoot range
:	:	:	:	:	:	
1300.1	13001	32C9 <sub>H</sub>	2372.1	23721	5CA9 <sub>H</sub>	Rated range
1300.0	13000	32C8 <sub>H</sub>	2372.0	23720	5CA8 <sub>H</sub>	
:	:	:	:	:	:	Underflow
-270.0	-2700	F574 <sub>H</sub>	-454.0	-4540	EE44 <sub>H</sub>	
< -270.0	-32768	8000 <sub>H</sub>	-32768	8000 <sub>H</sub>	<EE44 <sub>H</sub>	

### Measuring range for thermocouple types R, S

Table 4-21 SIMATIC S7 format: Measuring range Type R, S in °C and °F

Type R, S in °C	Units		Type R, S in °F	Units		Range
	Decimal	Hexadecimal		Decimal	Hexadecimal	
> 2019.0	32767	7FFF <sub>H</sub>	> 3276.6	32767	7FFF <sub>H</sub>	Overflow
2019.0	20190	4EDE <sub>H</sub>	3276.6	32766	7FFE <sub>H</sub>	Overshoot range
:	:	:	:	:	:	
1769.1	17691	451B <sub>H</sub>	3216.3	32163	7DA3 <sub>H</sub>	Rated range
1769.0	17690	451A <sub>H</sub>	3216.2	32162	7DA2 <sub>H</sub>	
:	:	:	:	:	:	Undershoot range
-50.0	-500	FE0C <sub>H</sub>	-58.0	-580	FDBC <sub>H</sub>	
-50.1	-510	FE0B <sub>H</sub>	-58.1	-581	FDBB <sub>H</sub>	Underflow
:	:	:	:	:	:	
-170.0	-1700	F95C <sub>H</sub>	-274.0	-2740	F54C <sub>H</sub>	
< -170.0	-32768	8000 <sub>H</sub>	< -274.0	-32768	8000 <sub>H</sub>	

### Measuring range for thermocouple type T

Table 4-22 SIMATIC S7 format: Measuring range Type T in °C and °F

Type T in °C	Units		Type T in °F	Units		Range
	Decimal	Hexadecimal		Decimal	Hexadecimal	
> 540.0	32767	7FFF <sub>H</sub>	> 1004.0	32767	7FFF <sub>H</sub>	Overflow
540.0	5400	1518 <sub>H</sub>	1004.0	10040	2738 <sub>H</sub>	Overshoot range
:	:	:				
400.1	4001	0FA1 <sub>H</sub>	752.1	7521	1DC1 <sub>H</sub>	Rated range
400.0	4000	0FA0 <sub>H</sub>	752.0	7520	1D60 <sub>H</sub>	
:	:	:	:	:	:	Underflow
-270.0	-2700	F574 <sub>H</sub>	-454.0	-4540	EE44 <sub>H</sub>	
< -270.0	-32768	8000 <sub>H</sub>	< -454.0	-32768	8000 <sub>H</sub>	

### 4.2.6 Output ranges of the analog output modules in SIMATIC S7 format for voltage and current

#### Output modules for voltage and current: ± 5 V; ± 10 V; ± 20 mA

Table 4-23 SIMATIC S7 format: output range ± 5 V; ± 10 V; ± 20 mA

Output range ± 5 V	Output range ± 10 V	Output range ± 20 V	Units		Range
			Decimal	Hexadecimal	
0	0	0	> 32511	> 7EFF <sub>H</sub>	Overflow
5.8800	11.7589	23.5150	32511	7EFF <sub>H</sub>	Overshoot range
:	:	:	:	:	
5.0002	10.0004	20.0007	27649	6C01 <sub>H</sub>	Rated range
5.0000	10.0000	20.0000	27648	6C00 <sub>H</sub>	
3.7500	7.5000	14.9980	20736	5100 <sub>H</sub>	Underflow
:	:	:	:	:	
- 3.7500	- 7.5000	- 14.9980	-20736	AF00 <sub>H</sub>	
- 5.0000	- 10.0000	- 20.0000	-27648	9400 <sub>H</sub>	
- 5.0002	- 10.0004	- 20.0007	-27649	93FF <sub>H</sub>	
:	:	:	:	:	
- 5.8800	- 11.7589	- 23.5160	-32512	8100 <sub>H</sub>	
0	0	< - 23.5160	< -32512	< 8100 <sub>H</sub>	Underflow

Output modules for voltage and current: 1 V to 5 V; 4 mA to 20 mA

Table 4-24 SIMATIC S7 format: Output ranges 1 V to 5 V; 4 mA to 20 mA

Output range Up to 5 V	Output range up to 20 mA	Units		Range
		Decimal	Hexadecimal	
0	0	> 32511	> 7EFF <sub>H</sub>	Overflow
5.7000	22.8100	32511	7EFF <sub>H</sub>	Overshoot range
:	:	:	:	
5.0002	20.0005	27649	6C01 <sub>H</sub>	
5.0000	20.0000	27648	6C00 <sub>H</sub>	Rated range
:	:	:	:	
1.0000	4.0000	0	0 <sub>H</sub>	
0.9998	3.9995	-1	FFFF <sub>H</sub>	Undershoot range
:	:	:	:	
0	0	-6912	E500 <sub>H</sub>	
0	0	< -6913	< E4FF <sub>H</sub>	Underflow

### 4.3 Basics of Analog Value Processing

#### 4.3.1 Connecting measuring sensors

##### Introduction

You can connect different measuring sensors to the analog input modules, depending on the type of module involved:

- Voltage sensor
- Current sensors as:
  - 2-wire transducer
  - 4-wire transducer
- Resistance-type sensor

In this chapter you will find out how to connect the measuring sensors and what to watch for when doing so.

##### Lines for analog signals

You should use shielded and twisted-pair lines for the analog signals. This reduces the effect of interference. You should ground the shield of the analog lines at both ends of the line. If there are differences in potential between the ends of the line, a compensating current flows via the shield that can interfere with the analog signals. If this is the case, you should only ground the shield at one end of the line.



### Analog Input Modules

In the case of the analog input modules there is galvanic isolation:

- Between the logic circuitry and backplane bus
- Between the load voltage and the channels. The following differences exist:
  - No isolation: Link between  $M_{ANA}$  and central grounding point
  - Isolation: No link between  $M_{ANA}$  and the central grounding point ( $U_{ISO}$ )

### Analog Output Modules

In the case of the analog output modules there is generally galvanic isolation:

- Between the logic circuitry and backplane bus
- Between the load voltage and  $M_{ANA}$ .

---

#### Note

Ensure that this potential difference  $U_{ISO}$  does not exceed the permitted value. If there is a possibility of exceeding the permitted value, make a connection between terminal  $M_{ANA}$  and the central grounding point.

---

### Connecting measuring sensors to analog inputs

Between the measuring lines M- of the input channels and the reference point of the measuring circuit  $M_{ANA}$  there can be only a limited potential difference  $U_{CM}$  (common-mode voltage). To ensure that the permitted value is not exceeded, you must take different steps depending on the whether the sensors are isolated or non-isolated. The steps you have to take are described in this chapter.

Generally speaking, however, when connecting two-wire measuring transducers for current measurement and when connecting resistance-type sensors, you should not make a connection from M- to  $M_{ANA}$ . This also applies to inputs that have been assigned parameters correspondingly but unused.

---

#### Note

For the analog input modules 2AI U, 2AI RTD, and 2AI TC, you must short-circuit unused analog inputs.

---

### Abbreviations used

The meanings of the abbreviations in the figures below are as follows:

M +	Measuring line (positive)
M -	Measuring line (negative)
$M_{ANA}$	Reference potential of the analog measuring circuit
M	Frame connection
L +	Rated load voltage 24 VDC
$U_{CM}$	Potential difference between inputs and reference potential of the measuring circuit $M_{ANA}$
$U_{ISO}$	Potential difference between $M_{ANA}$ and central grounding point

**Isolated measuring sensors**

The isolated measuring sensors are not connected to the local ground potential. They can be floating. Depending on local conditions or interference, potential differences  $U_{CM}$  (static or dynamic) can occur between the measuring lines M- of the input channels and the reference point of the measuring circuit  $M_{ANA}$ .

To ensure that the permitted value for  $U_{CM}$  is not exceeded in environments with strong EMC interference, the following applies:

- In the case of the analog input modules 2AI U, 2AI I 4WIRE, and 2AI TC: Connect M- with  $M_{ANA}$ !
- When connecting two-wire measuring transducers for current measurement and when connecting resistance-type sensors, you must not connect M- to  $M_{ANA}$ .

The following figure illustrates the connection of isolated measuring sensors to the floating analog input modules.

Connection of isolated measuring sensors to a floating analog input module:

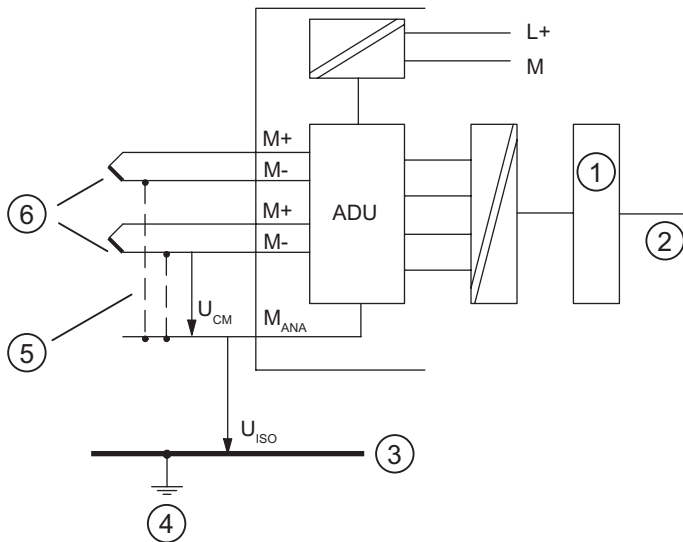

- (1) Logic
- (2) Backplane bus
- (3) Ground bus
- (4) Central grounding point
- (5) Recommended connection
- (6) Isolated measuring sensors

### Non-isolated measuring sensors

The non-isolated measuring sensors are connected to the local ground potential. You must connect  $M_{ANA}$  to the ground potential. Depending on local conditions or interference, potential differences  $U_{CM}$  (static or dynamic) can occur between the locally distributed measuring points.

If the permitted value for  $U_{CM}$  is exceeded, there must be equipotential bonding conductors between the measuring points.

The following figure illustrates the connection of non-isolated measuring sensors to a floating analog input module.

Connection of non-isolated measuring sensors to a floating analog input module:

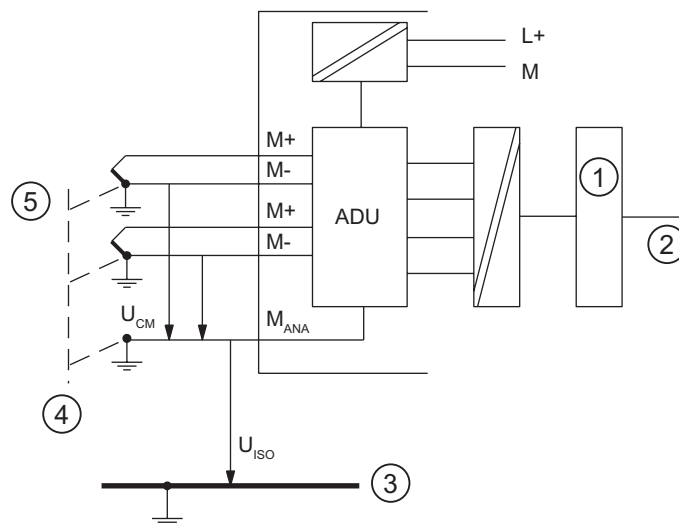

- (1) Logic
- (2) Backplane bus
- (3) Ground bus
- (4) Equipotential bonding cable
- (5) Non-isolated measuring sensors

### Operating four-wire measuring transducers on an external voltage supply

If there is isolation between the output and the supply of the measuring transducer, you can connect it to the 2AI I 4WIRE without additional connections.

If there is no isolation between the output and the supply of the measuring transducer, you can connect it to the 2AI I 4WIRE only if the reference potential of the power supply voltages (24 VDC) is the same.

If there is an increase in interference radiation, a connection between M- and  $M_{ANA}$  on the terminal module of the 2AI I 4WIRE is recommended.

### 4.3.2 Connecting Thermocouples

#### Introduction

This section contains additional information on connecting thermocouples.

#### Compensation of the reference junction temperature

There are various ways of obtaining the reference junction temperature in order to get an absolute temperature value from the temperature difference between the reference junction and the measuring point.

Table 4-25 Compensation of the reference junction temperature

Option	Description	Reference junction parameters
No compensation	You record not only the temperature of the measurement point. The temperature of the reference junction (transition from Cu line to thermocouple line) also affects the thermo-electromotive force. The measured value is thus erred.	None
Use of a compensating box on the incoming lines of a single thermocouple	You compensate using a compensating box. The compensating box is the transition point from the Cu line to the thermocouple line. No further processing is necessary through the 2AI TC Standard.	None
Use of a Pt 100 Climatic Range resistance thermometer to record the reference junction temperature (best method)	You can record the reference junction temperature using a resistance thermometer (Pt 100 Climatic Range). Given appropriate parameter assignment, this temperature value in the ET 200S is distributed to the 2AI TC Standard modules and calculated in the modules together with the temperature value obtained for the measurement point. Number of reference junctions: 1	The parameter assignment of the IM151-1 and the 2AI TC must be coordinated: <ul style="list-style-type: none"> <li>• 2AI RTD Standard assigned parameters to the Pt 100 climatic range at the correct slot;</li> <li>• 2AI TC Standard: Reference junction : RTD; select reference junction number 1</li> <li>• IM : Assignment of the reference junction to a slot with the 2AI RTD Standard; selection of a channel;</li> </ul>
Internal compensation in the case of the 2AI TC High Feature	There is a temperature sensor in the TM-E15S24-AT and TM-E15C24-AT terminal modules. The temperature sensor reports the temperature of the terminals to the 2AI TC High Feature. This value is then calculated together with the measured value from the channel of the electronic module.	<ul style="list-style-type: none"> <li>• 2AI TC High Feature: Reference junction: Yes</li> </ul>

### Extension to a reference junction

The thermocouples can be extended from their connection point by means of equalizing lines to the reference junction (transition to Cu line) or the compensating box. The reference junction can also be an ET 200S terminal module.

The equalization lines are made of the same material as the wires of the thermocouple. The incoming lines are made of copper. Ensure correct polarity when connecting.

### Use of a compensating box

The influence of the temperature on the reference junction of a thermocouple (for example, terminal boxes) can be adjusted with a compensating box.

The compensating box contains a bridge circuit that is adjusted for a certain reference junction temperature (compensating temperature). You connect the thermocouples or their adjustment lines to the compensating box. The compensating box then forms the reference junction.

If the actual reference temperature differs from the compensating temperature, the temperature-dependent bridge resistance changes. A positive or negative compensation voltage occurs that is added to the thermo-electromotive force.

Compensating boxes with a **reference junction temperature of 0 °C** must be used for the compensation of the analog input modules.

Pay attention to:

- The compensating box must be supplied on an isolated basis.
- The power supply unit must have adequate interference filtering (by means of a grounded shielding winding, for example).

**Compensation by means of a resistance thermometer at the 2AI RTD**

If thermocouples that are connected to the inputs of the 2AI TC have the same reference junction, compensate by means of a 2AI RTD.

For both channels of the 2AI TC module, you can select "RTD" or "None" as the reference junction. If you select "RTD," the same reference junction (RTD channel) is always used for both channels.

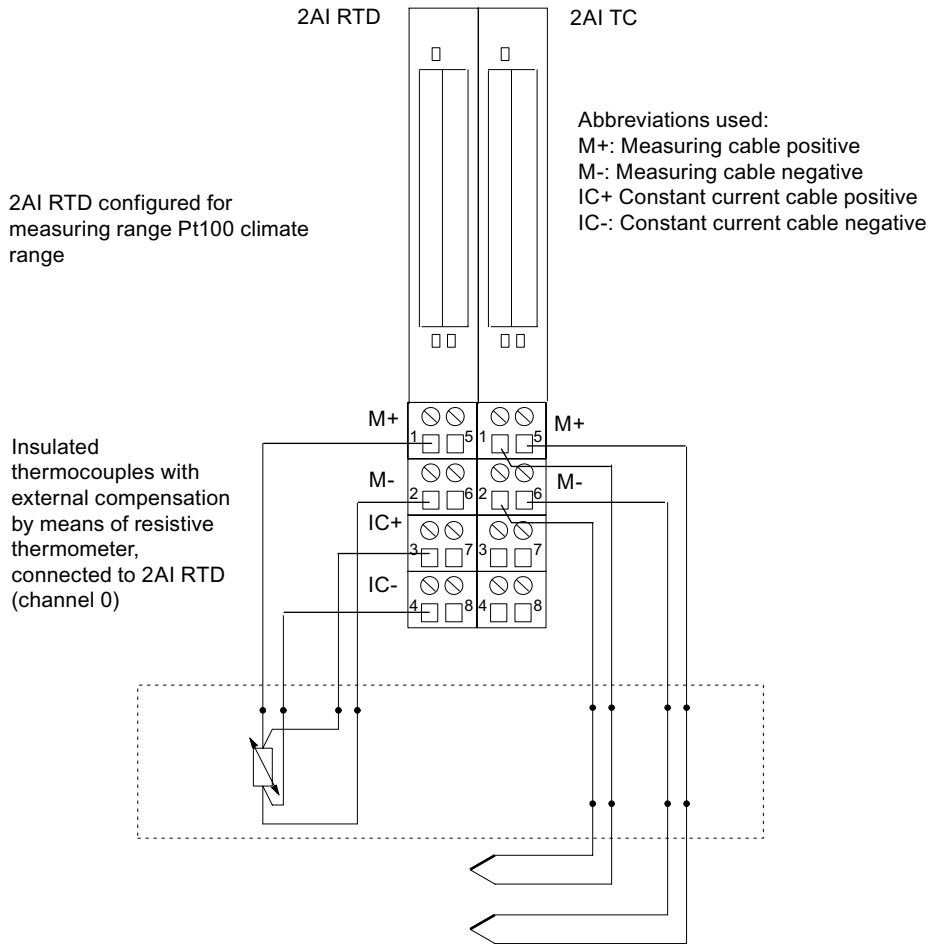

Figure 4-1 Compensation by means of the 2AI RTD

### Parameter assignment of the reference junction for the 2AI TC and the interface module

You set the reference junctions for the 2AI TC electronic modules by means of the following parameters:

Table 4-26 Reference junction parameters

Parameters	Module	Range of values	Description
Reference junction slot	IM 151	None, 2 to 12 (IM151-1 BASIC) None, 2 to 13 (IM151-1 COMPACT) none, 2 to 63 (IM151-1 HIGH FEATURE, IM151-1 STANDARD, IM151-1 FO STANDARD)	A slot with the channel for measuring the reference temperature (determining the compensation value) can be assigned with this parameter.
Reference junction input	IM 151	RTD at channel 0 RTD at channel 1	This parameter allows you to set the channel (0/1) for measuring the reference temperature (calculation of the compensation value) for the assigned slot.
Reference junction E0 and reference junction E1	AI TC	None, RTD	This parameter allows you to enable the use of the reference junction.
Reference junction number	AI TC	1	With this parameter, you assign the reference junction (1) containing the reference temperature (compensation value).

### Example of assigning parameters of reference junctions

Setup: For simplification, only RTD and TC modules are shown in the following figure:

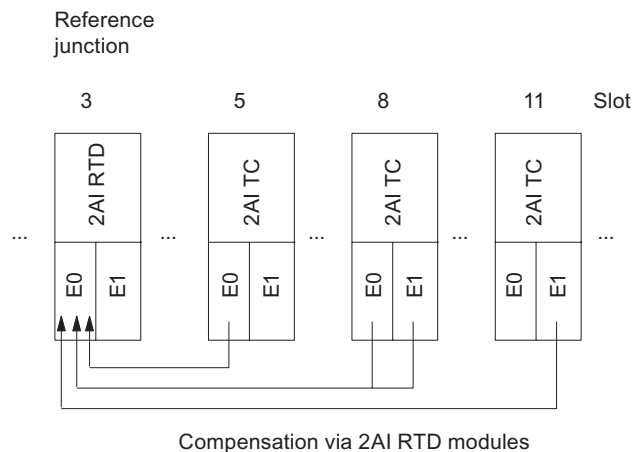

Figure 4-2 Example of assigning parameters of reference junctions

Relevant parameters to be set for the interface module:

Parameters	Value
Reference junction slot	3
Reference junction input	RTD at channel 0

Requires (relevant) parameters for 2AI RTD and 2AI TC:

Slot	Parameters	Value
3 (2AI RTD)	Type/range of measurement E0	RTD-4L Pt100 Climatic
	Type/range of measurement E1	(any)
5 (2AI TC)	Reference junction E0	RTD
	Reference junction E1	None
	Reference junction number	1
	Type/range of measurement E0	TC-EL Type...
	Type/range of measurement E1	(any)
8 (2AI TC)	Reference junction E0	RTD
	Reference junction E1	RTD
	Reference junction number	1
	Type/range of measurement E0	TC-EL Type...
	Type/range of measurement E1	TC-EL Type...
11 (2AI TC)	Reference junction E0	None
	Reference junction E1	RTD
	Reference junction number	1
	Type/range of measurement E0	(any)
	Type/range of measurement E1	TC-EL Type...

### Non-isolated thermocouples

When you use non-isolated thermocouples, you must comply with the permitted common-mode voltage.



### 4.3.3 Wiring unused channels of the analog input modules

#### Rules

Pay attention to the following instructions when wiring unused channels:

- "Disable" unused input channels when setting parameters.
- A disabled channel always returns the value 7FFF<sub>H</sub>.
- The module cycle time is halved with the standard modules 2AI U, 2AI I 2WIRE, 2AI I 4WIRE, 2AI RTD Standard, 2AI RTD High Feature and 2AI TC Standard, 2AI TC High Feature.
- The cycle time remains unchanged with the standard module 4AI I 2WIRE.
- The cycle time remains unchanged at 1 ms with the HIGH SPEED modules 2AI U, 2AI I 2WIRE and 2AI I 4WIRE.
- To maintain the allowable potential differences ( $U_{CM}$ ) bridges must be wired at the terminal module with the unused channels. This is required with the following modules:

Analog Input Module	TM connection terminal							
	Channel 0				Channel 1			
	1	2	3	4	5	6	7	8
2AI U Standard	● — ● — ●				● — ● — ●			
2AI RTD Standard, 2AI RTD High Feature, 2AI TC High Feature	● — ●				● — ●			
2AI TC Standard	● — ● — ●				● — ● — ●			
2AI U High Speed	● — ● — ●				● — ● — ●			

## 4.4 Response of the Analog Modules during Operation and if Faults Occur

### 4.4.1 Influence of the power supply and the operating status on analog input and output values

The input and output values of the analog modules are dependent on the power supply for electronics/sensors and on the operating state of the PLC (CPU of the DP master). The table below shows this dependency..

Table 4-27 Dependence of the Input and Output Values on the Operating State of the PLC (CPU of the DP Master) and the Power Supply Voltage L+

Operating State of the PLC (CPU of the DP Master)		Power supply L+ on ET 200S (power module)	Input Value of the Electronics Module with Analog Inputs (Evaluation Possible on the CPU of the DP Master)	Output Value of the Electronics Module with Analog Outputs
POWER ON	RUN	L+ present	Process values 7FFF <sub>H</sub> until first conversion after startup, or after assignment of parameters for the module is completed.	PLC values Until first value output: <ul style="list-style-type: none"> <li>After startup, a signal of 0 mA or 0 V is output.</li> <li>Dependent on the parameter "CPU/ master STOP"</li> </ul>
		L+ missing	7FFF <sub>H</sub>	-
POWER ON	STOP	L+ present	Process value	Dependent on the parameter "CPU/ master STOP"
		L+ missing	7FFF <sub>H</sub>	-
POWER OFF	-	L+ present	-	Dependent on the parameter "CPU/ master STOP"
		L+ missing	-	-

#### 4.4.2 Influence of the Value Range on the Analog Input

The response of the electronics modules with analog inputs depends on the part of the value range in which the input values are located. The table below shows this dependency..

Table 4-28 Response of the Analog Modules, Depending on the Location of the Analog Input Value in the Range of Values

Measured value within ...	Input value in SIMATIC S7 Format	Input value in SIMATIC S5 Format
Rated range	Measured value	Measured value
Overshoot/undershoot range	Measured value	Measured value
Overflow	7FFF <sub>H</sub>	End of overshoot range +1 plus overflow bit
Underflow	8000 <sub>H</sub>	End of undershoot range -1 plus overflow bit
Before setting parameters or with faulty parameters <sup>1</sup>	7FFF <sub>H</sub>	7FFF <sub>H</sub>

<sup>1</sup> With 2AI U Standard, 2AI I 2WIRE Standard, 2AI I 4WIRE Standard, 2AI RTD Standard, 2AI TC Standard with product status 1 applies: If the parameter setting error diagnostics message is triggered because of incorrect parameter setting (e.g. wire break in measuring range  $\pm 20$  mA), the SF LED on the module lights and the diagnosis can be evaluated. In this status correct input values are sent to the DP master.

#### 4.4.3 Influence of the Value Range on the Analog Output

The response of the electronics modules with analog outputs depends on the part of the value range in which the output values are located. The table below shows this dependency..

Table 4-29 Response of the Analog Modules, Depending on the Location of the Analog Output Value in the Range of Values

Output Value is in ...	Input value in SIMATIC S5/S7 format
Rated range	Value from DP master
Overshoot/undershoot range	Value from DP master
Overflow	0-signal
Underflow	0-signal
Before setting parameters or with faulty parameters <sup>1</sup>	0-signal

<sup>1</sup> With 2AO U Standard, 2AO I Standard with product status 1 applies: If the configured substitute value is outside the nominal range, a diagnostics message for a parameter setting error is registered and the SF LED lights. In this status the output values transferred from the DP master are output at the analog output modules.

### 4.4.4 Using the shield connection

#### Rules

To prevent interference we recommend the following with the analog electronic modules:

- Use shielded wires to the sensors and actuators.
- Lay out the wire shields on the shield connection.
- Connect the shield connection with low impedance to the ground bus.

## 4.5 Parameters for analog electronic modules

### 4.5.1 Parameters for analog electronic modules 2AI U Standard, 2AI I 2WIRE Standard, 4AI I 2WIRE Standard, 2AI I 4WIRE Standard

Table 4-30 Parameters for analog input modules U, I Standard

2AI U Standard	2AI I 2WIRE Standard 4AI I 2WIRE Standard	2AI I 4WIRE Standard	Range of values	Default setting	Applicability
Group diagnosis (parameter assignment error, internal error)			<ul style="list-style-type: none"> <li>• disable</li> <li>• Enable</li> </ul>	disable	Module
Diagnostics: Overflow/underflow			<ul style="list-style-type: none"> <li>• disable</li> <li>• Enable</li> </ul>	disable	Module
Diagnostics: wire break <sup>2</sup>	Diagnostics: wire break	Diagnostics: wire break <sup>1</sup>	<ul style="list-style-type: none"> <li>• disable</li> <li>• Enable</li> </ul>	disable	Channel
Smoothing			<ul style="list-style-type: none"> <li>• None</li> <li>• Weak</li> <li>• Medium</li> <li>• Strong</li> </ul>	None	Channel
Type/range of measurement	---	---	<ul style="list-style-type: none"> <li>• De-activated</li> <li>• ± 5 V</li> <li>• Up to 5 V</li> <li>• ± 10 V</li> </ul>	± 10 V	Channel
---	Type/range of measurement	---	<ul style="list-style-type: none"> <li>• De-activated</li> <li>• 2 WIRE: 4 to 20 mA</li> </ul>	2 WIRE: 4 to 20 mA	Channel
---	---	Type/range of measurement	<ul style="list-style-type: none"> <li>• De-activated</li> <li>• 4 WIRE: 4 to 20 mA</li> <li>• 4 WIRE: ± 20 mA</li> </ul>	4 WIRE: 4 to 20 mA	Channel
<sup>1</sup> Only in the measuring range 4 mA to 20 mA <sup>2</sup> Only in the measuring range 1 V to 5 V					

**See also**

Connecting Thermocouples (Page 4-18)

**4.5.2 Parameters for analog electronic modules 2AI U High Feature and 2AI I 2/4WIRE High Feature**

Table 4-31 Parameters for analog electronic modules U, I High Feature

2AI U High Feature	2AI I 2/4WIRE High Feature	Range of values	Default setting	Applicability
Group diagnosis (parameter assignment error, internal error)		<ul style="list-style-type: none"> <li>• disable</li> <li>• Enable</li> </ul>	disable	Module
Diagnostics: Overflow/underflow		<ul style="list-style-type: none"> <li>• disable</li> <li>• Enable</li> </ul>	disable	Module
---	Diagnostics: Wire break <sup>1</sup>	<ul style="list-style-type: none"> <li>• disable</li> <li>• Enable</li> </ul>	disable	Channel
Smoothing		<ul style="list-style-type: none"> <li>• None</li> <li>• Weak</li> <li>• Medium</li> <li>• Strong</li> </ul>	None	Channel
Type/range of measurement	---	<ul style="list-style-type: none"> <li>• De-activated</li> <li>• <math>\pm 5</math> V</li> <li>• 1 V to 5 V</li> <li>• <math>\pm 10</math> V</li> </ul>	$\pm 10$ V	Channel
---	Type/range of measurement	<ul style="list-style-type: none"> <li>• De-activated</li> <li>• 4 to 20 mA</li> <li>• <math>\pm 20</math> mA</li> </ul>	4 to 20 mA	Channel
Interference frequency suppression		<ul style="list-style-type: none"> <li>• disable</li> <li>• Enable</li> </ul>	disable	Module
Run-time calibration		<ul style="list-style-type: none"> <li>• disable</li> <li>• Enable</li> </ul>	disable	Module

<sup>1</sup> Only in the measuring range 4 to 20 mA

**See also**

Connecting Thermocouples (Page 4-18)

**4.5.3 Parameters for analog electronic modules 2AI U High Speed, 2AI I 2WIRE High Speed and 2AI I 4WIRE High Speed**

Table 4-32 Parameters for analog input modules U, I High Speed

2AI U High Speed	2AI I 2WIRE High Speed	2AI I 4WIRE High Speed	Range of values	Default setting	Applicability
Group diagnosis (parameter assignment error, internal error)			<ul style="list-style-type: none"> <li>• disable</li> <li>• Enable</li> </ul>	disable	Module
Diagnostics: Overflow/underflow			<ul style="list-style-type: none"> <li>• disable</li> <li>• Enable</li> </ul>	disable	Module
---	Diagnostics: Wire break	Diagnostics: Wire break	<ul style="list-style-type: none"> <li>• disable</li> <li>• Enable</li> </ul>	disable	Channel
Smoothing			<ul style="list-style-type: none"> <li>• None</li> <li>• Weak</li> <li>• Medium</li> <li>• Strong</li> </ul>	None	Channel
Type/range of measurement	---	---	<ul style="list-style-type: none"> <li>• De-activated</li> <li>• ± 10 V</li> <li>• ± 5 V</li> <li>• ± 2.5 V</li> <li>• Up to 5 V</li> </ul>	± 10 V	Channel
---	Type/range of measurement	---	<ul style="list-style-type: none"> <li>• De-activated</li> <li>• 4 to 20 mA</li> <li>• 0 to 20 mA</li> </ul>	4 to 20 mA	Channel
---	---	Type/range of measurement	<ul style="list-style-type: none"> <li>• De-activated</li> <li>• 4 to 20 mA</li> <li>• 0 to 20 mA</li> <li>• ± 20 mA</li> </ul>	4 to 20 mA	Channel

**Note**

If you deactivate a channel of the HIGH SPEED modules, you do not achieve any speed advantage on account of the measuring procedure used.

**See also**

Connecting Thermocouples (Page 4-18)

#### 4.5.4 Parameters for analog electronic modules 2AI RTD Standard, 2AI TC Standard and 2AI TC High Feature

Table 4-33 Parameters for analog input modules RTD, TC

2AI RTD Standard	2AI TC Standard	2AI TC High Feature	Range of values	Default setting	Applicability
Group diagnosis (parameter assignment error, internal error)			<ul style="list-style-type: none"> <li>• disable</li> <li>• Enable</li> </ul>	disable	Module
Diagnostics: Overflow/underflow			<ul style="list-style-type: none"> <li>• disable</li> <li>• Enable</li> </ul>	disable	Module
Diagnostics: Wire break <sup>2</sup>	Diagnostics: Wire break check <sup>1</sup>		<ul style="list-style-type: none"> <li>• disable</li> <li>• Enable</li> </ul>	disable	Channel
Smoothing			<ul style="list-style-type: none"> <li>• None</li> <li>• Weak</li> <li>• Medium</li> <li>• Strong</li> </ul>	None	Channel
		Temperature unit	<ul style="list-style-type: none"> <li>• Celsius</li> <li>• Fahrenheit</li> </ul>	Celsius	Module
---	Reference junction	---	<ul style="list-style-type: none"> <li>• None</li> <li>• RTD</li> </ul>	None	Channel
---		Reference junction	<ul style="list-style-type: none"> <li>• None</li> <li>• Yes (i.e. internal)</li> </ul>	None	Channel
---	Reference junction number	---	<ul style="list-style-type: none"> <li>• None</li> <li>• 1 to 8 (in the case of the IM151-1 STANDARD and IM151-1 FO STANDARD)</li> <li>• 1 (in the case of the IM151-1 BASIC, IM151-1 COMPACT, IM151-1 HIGH FEATURE)</li> </ul>	None	Module
Type/range of measurement	---		<ul style="list-style-type: none"> <li>• De-activated</li> <li>• 150 ohm</li> <li>• 300 ohm</li> <li>• 600 ohm</li> <li>• Pt100 Climatic</li> <li>• Ni100 Climatic Range</li> <li>• Pt100 Standard</li> <li>• Ni100 Standard</li> </ul>	Pt100 Standard	Channel
---	Type/range of measurement	---	<ul style="list-style-type: none"> <li>• De-activated</li> <li>• Voltage <math>\pm</math> 80 mV</li> <li>• TC-EL type T (Cu-CuNi)</li> <li>• TC-EL type K (NiCr-Ni)</li> <li>• TC-EL type B (PtRh-PtRh)</li> <li>• TC-EL type N (NiCrSi-NiSi)</li> <li>• TC-EL type E (NiCr-CuNi)</li> <li>• TC-EL type R (PtRh-Pt)</li> <li>• TC-EL type S (PtRh-Pt)</li> <li>• TC-EL type J (Fe-Cu-Ni)</li> <li>• TC-EL type L (Fe-Cu-Ni)</li> </ul>	TC-EL type K (NiCr-Ni)	Channel

4.5 Parameters for analog electronic modules

2AI RTD Standard	2AI TC Standard	2AI TC High Feature	Range of values	Default setting	Applicability
		Type/range of measurement	<ul style="list-style-type: none"> <li>De-activated</li> <li>Voltage <math>\pm 80</math> mV</li> <li>TC-EL type T (Cu-CuNi)</li> <li>TC-EL type K (NiCr-Ni)</li> <li>TC-EL type B (PtRh-PtRh)</li> <li>TC-EL type C (WRe-WRe)</li> <li>TC-EL type N (NiCrSi-NiSi)</li> <li>TC-EL type E (NiCr-CuNi)</li> <li>TC-EL type R (PtRh-Pt)</li> <li>TC-EL type S (PtRh-Pt)</li> <li>TC-EL type J (Fe-Cu-Ni)</li> <li>TC-EL type L (Fe-Cu-Ni)</li> </ul>	TC-EL type K (NiCr-Ni)	Channel
<p><sup>1</sup> Only with thermocouples. A parameter assignment error occurs when the wire break diagnosis is enabled in the voltage measuring range. The module does not start up.</p> <p><sup>2</sup> The wire break is only detected with constant-current lines.</p>					

See also

Connecting Thermocouples (Page 4-18)

4.5.5 Parameters for 2AI RTD High Feature analog electronic module

Table 4-34 Parameters for 2AI RTD High Feature analog electronic module

Parameters	Range of values	Default setting	Applicability
Group diagnostics	<ul style="list-style-type: none"> <li>Disable</li> <li>Enable</li> </ul>	Disable	Module
Diagnostics: overflow/underflow	<ul style="list-style-type: none"> <li>Disable</li> <li>Enable</li> </ul>	Disable	Module
Diagnostics: Wire break	<ul style="list-style-type: none"> <li>Disable<sup>1</sup></li> <li>Enable</li> </ul>	Disable	Channel
Smoothing	<ul style="list-style-type: none"> <li>None</li> <li>Weak</li> <li>Medium</li> <li>Strong</li> </ul>	None	Channel
Temperature unit	<ul style="list-style-type: none"> <li>Celsius</li> <li>Fahrenheit</li> </ul>	Celsius	Module
Type of measurement	<ul style="list-style-type: none"> <li>De-activated</li> <li>Four-wire resistor</li> <li>Three-wire resistor</li> <li>Two-wire resistor</li> <li>Four-wire thermal resistor</li> <li>Three-wire thermal resistor</li> <li>Two-wire thermal resistor</li> </ul>	Four-wire thermal resistor	Channel



Parameters	Range of values	Default setting	Applicability
Temperature coefficient	<ul style="list-style-type: none"> <li>• Pt 0.003850</li> <li>• Pt 0.003916</li> <li>• Pt 0.003902</li> <li>• Pt 0.003920</li> <li>• Pt 0.003851</li> <li>• Ni 0.006180</li> <li>• Ni 0.006720</li> <li>• Ni 0.005000</li> <li>• Cu 0.00427</li> </ul>	Pt 0.003851	Channel
Measuring range	<ul style="list-style-type: none"> <li>• 150 Ω</li> <li>• 300 Ω</li> <li>• 600 Ω</li> <li>• 3000 Ω</li> <li>• PTC</li> <li>• Pt100 Climatic</li> <li>• Ni100 Climatic Range</li> <li>• Pt100 Standard</li> <li>• Ni100 Standard</li> <li>• Pt500 standard range</li> <li>• Pt1000 standard range</li> <li>• Ni1000 standard range</li> <li>• Pt200 climatic range</li> <li>• Pt500 climatic range</li> <li>• Pt1000 climatic range</li> <li>• Ni1000 climatic range</li> <li>• Pt200 standard range</li> <li>• Ni120 standard range</li> <li>• Ni120 climatic range</li> <li>• Cu10 climatic range</li> <li>• Cu10 standard range</li> <li>• Ni200 standard range</li> <li>• Ni200 climatic range</li> <li>• Ni500 standard range</li> <li>• Ni500 climatic range</li> </ul>	Pt100 Standard	Channel
<sup>1</sup> Wire break diagnostic is disabled if - Type of measurement = "deactivated" or Measuring Range = "PTC" was assigned.			

### Type of measurement

The following table lists the temperature coefficients and measuring ranges you can set for each measurement type:

Type of measurement	Temperature coefficient	Measuring range
De-activated	–	–
Four-wire resistor Three-wire resistor	–	150 Ω / 300 Ω / 600 Ω / 3000 Ω
Two-wire resistor	–	150 Ω / 300 Ω / 600 Ω / 3000 Ω / PTC
Three-wire thermal resistor	Pt 0.003850 / Pt 0.003916 / Pt 0.003902 / Pt 0.003920 / Pt 0.003851 <sup>1</sup>	Pt100 climatic range / Pt100 standard range / Pt200 climatic range / Pt200 standard range / Pt500 climatic range / Pt500 standard range / Pt1000 climatic range / Pt1000 standard range
	Ni 0.006180 <sup>1</sup> / Ni 0.006720	Ni100 climatic range / Ni100 standard range / Ni120 climatic range / Ni120 standard range / Ni200 climatic range / Ni200 standard range / Ni500 climatic range / Ni500 standard range / Ni1000 climatic range / Ni1000 standard range
	Ni 0.005000	Ni 1000 climatic range <sup>2</sup> Ni 1000 standard range <sup>2</sup>
	Cu 0.00427 <sup>1</sup>	Cu10 climatic range / Cu10 standard range
Two-wire thermal resistor Four-wire thermal resistor	Pt 0.003850 / Pt 0.003916 / Pt 0.003902 / Pt 0.003920 / Pt 0.003851	Pt100 climatic range / Pt100 standard range / Pt200 climatic range / Pt200 standard range / Pt500 climatic range / Pt500 standard range / Pt1000 climatic range / Pt1000 standard range
	Ni 0.006180 / Ni 0.006720	Ni100 climatic range / Ni100 standard range / Ni120 climatic range / Ni120 standard range / Ni200 climatic range / Ni200 standard range / Ni500 climatic range / Ni500 standard range / Ni1000 climatic range / Ni1000 standard range
	Ni 0.005000	Ni 1000 climatic range <sup>2</sup> Ni 1000 standard range <sup>2</sup>

<sup>1</sup> The default settings for the temperature coefficients are valid for Europe.  
<sup>2</sup> For LG-Ni 1000 sensors from Siemens Building Ltd (Landis & Stäfa)

## Temperature coefficient

The correction factor for the temperature coefficient ( $\alpha$ -value) specifies how much the resistance of a certain material changes when the temperature is raised by 1° C.

The temperature coefficient depends on the chemical composition of the material. Only one value is used in Europe for each type of sensor (default value).

Additional values enable you to make a sensor-specific setting for the temperature coefficient, therefore ensuring more accuracy.

## See also

Connecting Thermocouples (Page 4-18)

## 4.5.6 Parameters for analog electronic modules 2AO U Standard, 2AO U High Feature and 2AO I Standard, 2AO I High Feature

Table 4-35 Parameters for analog output modules U, I

2AO U Standard, 2AO U High Feature	2AO I Standard, 2AO I High Feature	Range of values	Default setting	Applicability
Group diagnosis (parameter assignment error, internal error)		<ul style="list-style-type: none"> <li>• Disable</li> <li>• Enable</li> </ul>	Disable	Module
Diagnostics: Short-circuit to M	---	<ul style="list-style-type: none"> <li>• Disable</li> <li>• Enable</li> </ul>	Disable	Channel
---	Diagnostics: Wire break	<ul style="list-style-type: none"> <li>• Disable</li> <li>• Enable</li> </ul>	Disable	Channel
Reaction to CPU-/master-STOP		<ul style="list-style-type: none"> <li>• No output current and voltage</li> <li>• Substitute a value</li> <li>• Keep last value</li> </ul>	No output current and voltage	Module
Type/range of output	---	<ul style="list-style-type: none"> <li>• De-activated</li> <li>• 1 V to 5 V</li> <li>• <math>\pm 10</math> V</li> </ul>	$\pm 10$ V	Channel
---	Type/range of output	<ul style="list-style-type: none"> <li>• De-activated</li> <li>• 4 to 20 mA</li> <li>• <math>\pm 20</math> mA</li> </ul>	4 to 20 mA	Channel
Substitute value <sup>1</sup>		To 65535 (value range must be within the nominal range)	<ul style="list-style-type: none"> <li><math>\pm 10</math> V: 0 V</li> <li><math>\pm 20</math> mA: 0 mA</li> <li>4 mA to 20 mA: 4 mA</li> <li>1 V to 5 V: 1 V</li> </ul>	Channel

<sup>1</sup> If there is no voltage going to the interface module or COMPACT module but the supply to the analog output modules continues, the substitute values that have been assigned parameters are output. Substitute values must be within the nominal range. You can assign as parameters values from -27648 to +27648 (in the case of parameter assignment by means of the device database file).

See also

Connecting Thermocouples (Page 4-18)

### 4.5.7 Parameters of the Analog Electronic Modules

#### Smoothing

The individual measured values are smoothed by digital filtering. The smoothing can be adjusted in four steps, in which the smoothing factor  $k$  multiplied with cycle time of the electronic module equals the time constant of the smoothing filter. The higher the smoothing the greater the time constant of the filter.

The following diagrams show the step response with the various smoothing factors depending on the number of subassembly cycles.

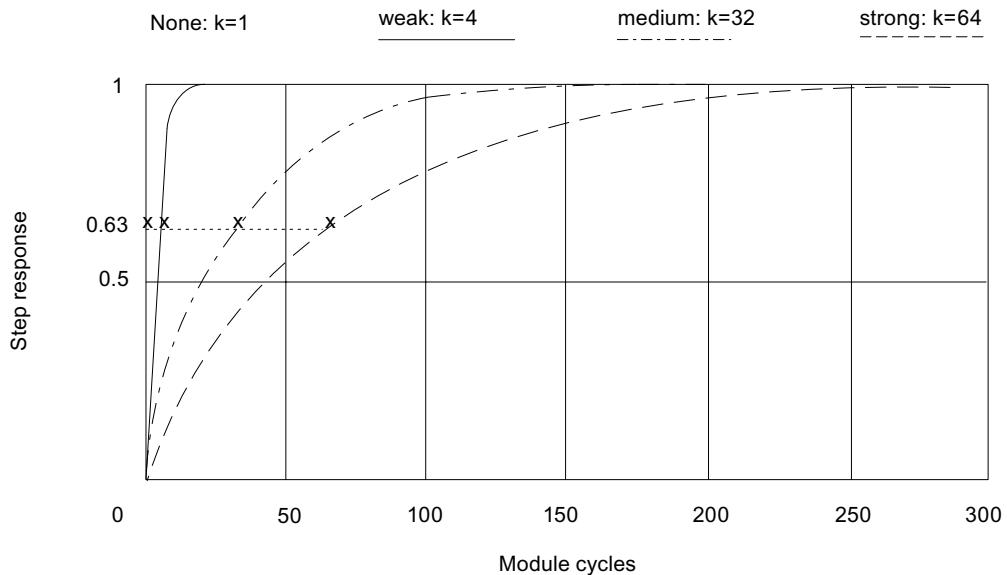

Figure 4-3 Smoothing with the 2AI U Standard, 2AI U High Feature, 2AI I 2WIRE Standard, 2AI I 4WIRE Standard, 2AI I 2/4WIRE High Feature, 2AI RTD Standard, 2AI RTD High Feature, 2AI TC Standard, 2AI TC High Feature

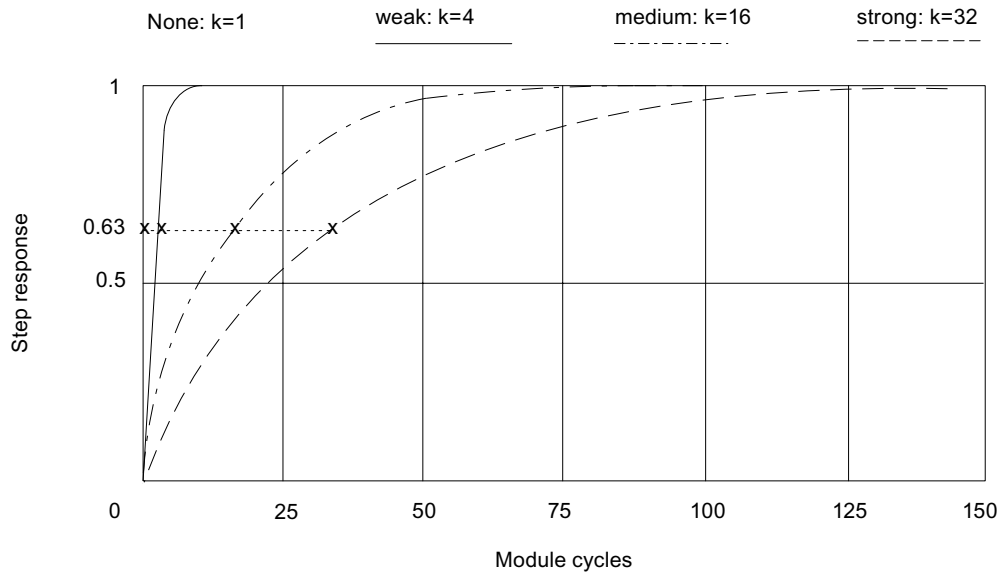

Figure 4-4 Smoothing with 4AI I 2WIRE Standard

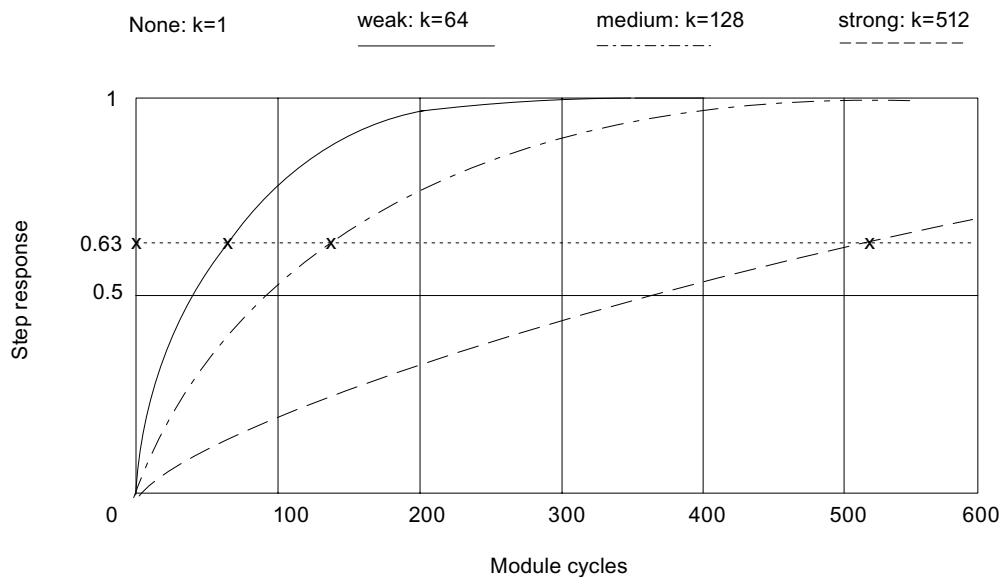

Figure 4-5 Smoothing with 2AI U High Speed, 2AI I 2WIRE High Speed, 2AI I 4WIRE High Speed

### Interference frequency suppression

The analog input modules 2AI U High Feature and 2AI I 2/4WIRE High Feature support the setting of the interference frequency suppression (50 Hz or 60 Hz) at the interface module. These analog input modules (HIGH FEATURE) also allow the interference frequency suppression to be disabled; i.e., this setting can be ignored on the interface module. If the interference suppression is disabled, the conversion and cycle times in these modules are improved.

### Run-time calibration

- 2AI U High Feature

When setting the module parameters the runtime calibration for the 2AI U High Feature analog electronic module can be enabled to compensate for component drift resulting from changes in the ambient temperature. During the calibration interval, the updating of new data is delayed by 250 ms. Calibration takes place each time the ambient temperature changes by 5 °C.

- 2AI I 2/4WIRE High Feature

When setting the module parameters a runtime calibration for the 2AI I 2/4WIRE High Feature analog electronic module can be enabled for periodic compensation of the offset voltage drift of the A/D converter. During the calibration interval, the updating of new data is delayed by 200 ms. The accuracy limits of the module will be met without run-time calibration.

### Reference Junction, Reference Junction Number

See *Connection of thermocouples*.

### See also

Connecting Thermocouples (Page 4-18)

## 4.6 2AI U Standard analog electronic module (6ES7134-4FB01-0AB0)

### Properties

- 2 inputs for measuring voltage
- Input ranges:
  - ± 10 V, resolution 13 bits + sign
  - ± 5 V, resolution 13 bits + sign
  - 1 to 5 V, resolution 13 bits
- Isolated from the load voltage L+
- Permissible common mode voltage AC 2 V<sub>SS</sub>

### General terminal assignment

---

#### Note

Terminals 4, 8, A4, A8, A3 and A7 are only available at specified terminal modules.

---

Terminal assignment for 2AI U Standard (6ES7134-4FB01-0AB0)				
Terminal	Assignment	Terminal	Assignment	Notes
1	M <sub>0+</sub>	5	M <sub>1+</sub>	<ul style="list-style-type: none"> <li>• M<sub>n+</sub>: Input signal "+", channel n</li> <li>• M<sub>n-</sub>: Input signal "-", channel n</li> <li>• M<sub>ana</sub>: Ground of the module</li> <li>• n.c.: Not connected (max. DC 30 V can be connected)</li> <li>• AUX1: Protective-conductor terminal or potential bus (freely usable up to 230 VAC)</li> </ul>
2	M <sub>0-</sub>	6	M <sub>1-</sub>	
3	M <sub>ana</sub>	7	M <sub>ana</sub>	
4	n.c.	8	n.c.	
A4	AUX1	A8	AUX1	
A3	AUX1	A7	AUX1	

Usable terminal modules

Usable terminal modules for 2AI U Standard (6ES7134-4FB01-0AB0)				
TM-E15C26-A1 (6ES7193-4CA50-0AA0)	TM-E15C24-A1 (6ES7193-4CA30-0AA0)	TM-E15C24-01 (6ES7193-4CB30-0AA0)	TM-E15C23-01 (6ES7193-4CB10-0AA0)	← Spring terminal
TM-E15S26-A1 (6ES7193-4CA40-0AA0)	TM-E15S24-A1 (6ES7193-4CA20-0AA0)	TM-E15S24-01 (6ES7193-4CB20-0AA0)	TM-E15S23-01 (6ES7193-4CB00-0AA0)	← Screw terminal
TM-E15N26-A1 (6ES7193-4CA80-0AA0)	TM-E15N24-A1 (6ES7193-4CA70-0AA0)	TM-E15N24-01 (6ES7193-4CB70-0AA0)	TM-E15N23-01 (6ES7193-4CB60-0AA0)	← Fast Connect
				<p>Wiring examples</p>

Block diagram

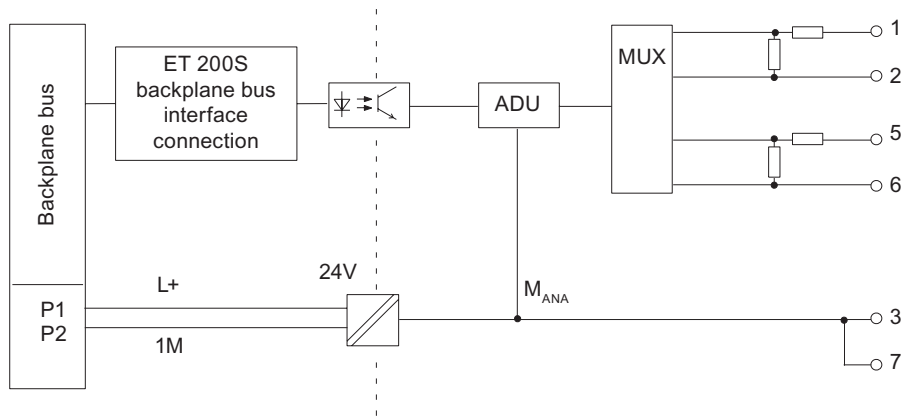

Figure 4-6 Block diagram of the 2AI U Standard



## 2AI U Standard Technical Specifications (6ES7134-4FB01-0AB0)

Dimensions and Weight	
Dimensions W × H × D (mm) (the total dimensions depend on the selected terminal module)	15 x 81 x 52
Weight	Approx. 40 g
Data for specific modules	
Supports isochronous operation	no
Number of inputs	2
Cable length	
• Shielded	max. 200 m
Parameter length	4 bytes
Voltages, currents, potentials	
Rated load voltage L+ (from the power module)	24 VDC
• Reverse polarity protection	Yes
Galvanic isolation	
• Between the channels and backplane bus	Yes
• Between the channels and load voltage L+	Yes
• Between the channels	no
Permissible potential difference	
• Between the inputs and M <sub>ANA</sub> (U <sub>CM</sub> )	2 V <sub>ACSS</sub>
• Between M <sub>ANA</sub> and the central grounding point (U <sub>ISO</sub> )	75 VDC / 60 VAC
Insulation tested	500 VDC
Current consumption	
• From load voltage L+	max. 30 mA
Power dissipation of the module	Typically 0.6 W
Status, interrupts, diagnostics	
Diagnostics function	
• Group error	Red "SF" LED
• Diagnostic functions readable	Yes
Analog value generation	
Measuring principle	Integrative
Integration and cycle time/resolution per channel:	
• Integration time can be assigned parameters	Yes
• Interference frequency suppression in Hz	60                      50
• Integration time in milliseconds	16.7                      20
• Conversion time in ms	55                        65
• Cycle time in ms	Number of active channels per module x conversion time
• Resolution (including overrange)	± 10 V/13 bits + sign ± 5 V/13 bits + sign 1 V to 5 V/13 bits

<b>Suppression of interference, limits of error</b>											
Interference voltage suppression for $f = n \times (f_1 \pm 1 \%)$ , ( $f_1$ = interference frequency)											
<ul style="list-style-type: none"> <li>• Common-mode interference (<math>U_{ss}</math>)</li> <li>• Series-mode interference (peak interference value &lt; rated value of input range)</li> <li>• Crosstalk between the inputs</li> </ul>	min. 90 dB min. 70 dB  min. -50 dB										
Operational limit (in the entire temperature range, with reference to the input range)	$\pm 0.6 \%$										
Basic error limit (operational limit at 25° C with reference to input range)	$\pm 0.4 \%$										
Temperature error (with reference to the input range)	$\pm 0.01 \%/K$										
Linearity error (with reference to the input range)	$\pm 0.01 \%$										
Repeatability (in steady state at 25° C with reference to input range)	$\pm 0.05 \%$										
<b>Data for selecting a sensor</b>											
Input range (rated value)/input resistance											
<ul style="list-style-type: none"> <li>• Voltage</li> </ul>	$\pm 5 \text{ V/min. } 100 \text{ k}\Omega$ 1 V to 5 V/min. 100 k $\Omega$ $\pm 10 \text{ V/min. } 100 \text{ k}\Omega$										
Permitted input voltage (destruction limit)	35 V continuous, 75 V at max. duration of 1 ms (sampling ratio 1:20)										
Smoothing of the measured values	Yes, can be assigned parameters in 4 steps by means of digital filtering										
	<table border="1" style="width: 100%; border-collapse: collapse;"> <thead> <tr> <th style="text-align: left;"><b>Step</b></th> <th style="text-align: left;"><b>Time constant</b></th> </tr> </thead> <tbody> <tr> <td>None</td> <td>1 x cycle time</td> </tr> <tr> <td>Weak</td> <td>4 x cycle time</td> </tr> <tr> <td>Medium</td> <td>32 x cycle time</td> </tr> <tr> <td>Strong</td> <td>64 x cycle time</td> </tr> </tbody> </table>	<b>Step</b>	<b>Time constant</b>	None	1 x cycle time	Weak	4 x cycle time	Medium	32 x cycle time	Strong	64 x cycle time
<b>Step</b>	<b>Time constant</b>										
None	1 x cycle time										
Weak	4 x cycle time										
Medium	32 x cycle time										
Strong	64 x cycle time										

## 4.7 2AI U High Feature analog electronic module (6ES7134-4FB00-0AB0)

### Properties

- 2 inputs for measuring voltage
- Input ranges:
  - $\pm 10$  V, resolution 15 bits + sign
  - $\pm 5$  V, resolution 15 bits + sign
  - 1 V to 5 V, resolution 15 bits
- Isolated from the load voltage L+
- Permitted common-mode voltage between the channels 100 VAC

### General terminal assignment

---

#### Note

Terminals 4, 8, A4, A8, A3 and A7 are only available at specified terminal modules.

---

Terminal assignment for 2AI U High Feature (6ES7134-4FB00-0AB0)				
Terminal	Assignment	Terminal	Assignment	Notes
1	M <sub>0+</sub>	5	M <sub>1+</sub>	<ul style="list-style-type: none"> <li>• M<sub>n+</sub>: Input signal "+", channel n</li> <li>• M<sub>n-</sub>: Input signal "-", channel n</li> <li>• n.c.: Not connected (max. DC 30 V can be connected)</li> <li>• AUX1: Protective-conductor terminal or potential bus (freely usable up to 230 VAC)</li> </ul>
2	M <sub>0-</sub>	6	M <sub>1-</sub>	
3	n.c.	7	n.c.	
4	n.c.	8	n.c.	
A4	AUX1	A8	AUX1	
A3	AUX1	A7	AUX1	

Usable terminal modules

Usable terminal modules for 2AI U High Feature (6ES7134-4FB00-0AB0)				
TM-E15C26-A1 (6ES7193-4CA50-0AA0)	TM-E15C24-A1 (6ES7193-4CA30-0AA0)	TM-E15C24-01 (6ES7193-4CB30-0AA0)	TM-E15C23-01 (6ES7193-4CB10-0AA0)	← Spring terminal
TM-E15S26-A1 (6ES7193-4CA40-0AA0)	TM-E15S24-A1 (6ES7193-4CA20-0AA0)	TM-E15S24-01 (6ES7193-4CB20-0AA0)	TM-E15S23-01 (6ES7193-4CB00-0AA0)	← Screw terminal
TM-E15N26-A1 (6ES7193-4CA80-0AA0)	TM-E15N24-A1 (6ES7193-4CA70-0AA0)	TM-E15N24-01 (6ES7193-4CB70-0AA0)	TM-E15N23-01 (6ES7193-4CB60-0AA0)	← Fast Connect
				<p>Wiring examples</p>

Block diagram

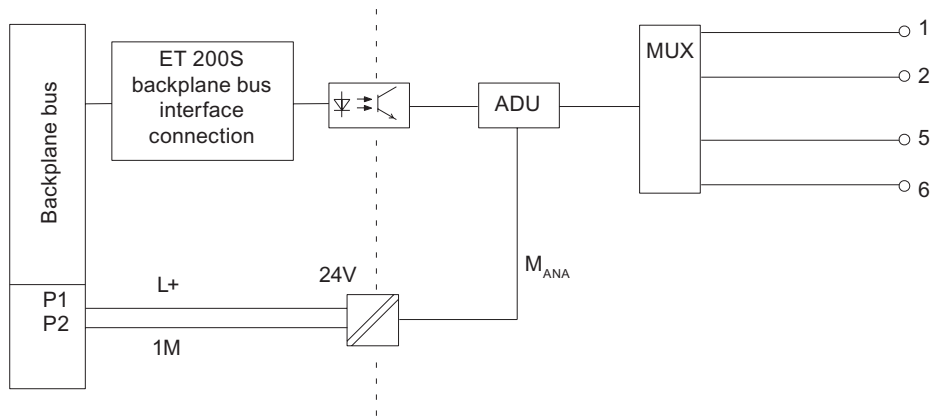

Figure 4-7 Block diagram of the 2AI U High Feature

## 2AI U High Feature Technical Specifications (6ES7134-4LB00-0AB0)

Dimensions and Weight			
Dimensions W × H × D (mm) (the total dimensions depend on the selected terminal module)	15 x 81 x 52		
Weight	Approx. 40 g		
Data for specific modules			
Supports isochronous operation	no		
Number of inputs	2		
Cable length			
• Shielded	max. 200 m		
Parameter length	4 bytes		
Voltages, currents, potentials			
Rated load voltage L+ (from the power module)	24 VDC		
• Reverse polarity protection	Yes		
Galvanic isolation			
• Between the channels and backplane bus	Yes		
• Between the channels and load voltage L+	Yes		
• Between the channels and PE	Yes		
• Between the channels	no		
Permissible potential difference			
• Between the channels	140 VDC / 100 VAC		
Insulation tested	500 VDC		
Current consumption			
• From load voltage L+	max. 53 mA		
Power dissipation of the module	Typically 0.85 W		
Status, interrupts, diagnostics			
Diagnostics function			
• Group error	Red "SF" LED		
• Diagnostic functions readable (wire break diagnosis is not supported on the module.)	Yes		
Analog value generation			
Measuring principle	Integrative		
Integration and cycle time/resolution per channel			
• Integration time can be assigned parameters	Yes		
• Interference frequency suppression in Hz	60	50	no
• Integration time in milliseconds	16.67	20	7.5
• Conversion time in ms			
– 1 channel active per module	25	30	10
– 2 channels active per module	58.3	70	26
• Cycle time in ms			
– 1 channel active per module	75	90	30
– 2 channels active per module	175	210	78

<ul style="list-style-type: none"> <li>Resolution (including overrange)</li> </ul>	<ul style="list-style-type: none"> <li><math>\pm 10 \text{ V}/15 \text{ bits} + \text{sign}</math></li> <li><math>\pm 5 \text{ V}/15 \text{ bits} + \text{sign}</math></li> <li>1 V to 5 V/15 bits</li> </ul>										
<b>Suppression of interference, limits of error</b>											
Interference voltage suppression for $f = n \times (f_1 \pm 0.5 \%)$ , ( $f_1 =$ interference frequency)											
<ul style="list-style-type: none"> <li>Common-mode interference (<math>U_{ss}</math>)</li> <li>Series-mode interference (peak interference value &lt; rated value of input range)</li> <li>Crosstalk between the inputs</li> </ul>	<ul style="list-style-type: none"> <li>min. 100 dB</li> <li>min. 90 dB</li> <li>min. -100 dB</li> </ul>										
Operational limit (entire temperature range with reference to input range; calibration enabled <sup>1</sup> )	$\pm 0.1 \%$										
Operational limit (entire temperature range with reference to input range; calibration disabled)	$\pm 0.5\%$										
Basic error limit (operational limit at 25° C with reference to input range; calibration enabled <sup>1</sup> )	$\pm 0.05\%$										
Temperature error (with reference to input range; calibration enabled <sup>1</sup> )	$\pm 0.003 \%/K$										
Temperature error (with reference to input range; calibration disabled)	$\pm 0.015 \%/K$										
Linearity error (with reference to the input range)	$\pm 0.03\%$										
Repeatability (in steady state at 25° C with reference to input range)	$\pm 0.01\%$										
<b>Data for selecting a sensor</b>											
Input range (rated value)/input resistance											
<ul style="list-style-type: none"> <li>Voltage</li> </ul>	<ul style="list-style-type: none"> <li><math>\pm 10 \text{ V}/\text{min. } 1 \text{ M}\Omega</math></li> <li><math>\pm 5 \text{ V}/\text{min. } 1 \text{ M}\Omega</math></li> <li>1 V to 5 V/min. 1 M<math>\Omega</math></li> </ul>										
Permitted input voltage (destruction limit)	35 V continuous, 75 V at max. duration of 1 ms										
Smoothing of the measured values	Yes, can be assigned parameters in 4 steps by means of digital filtering										
	<table border="1"> <thead> <tr> <th>Step</th> <th>Time constant</th> </tr> </thead> <tbody> <tr> <td>None</td> <td>1 x cycle time</td> </tr> <tr> <td>Weak</td> <td>4 x cycle time</td> </tr> <tr> <td>Medium</td> <td>32 x cycle time</td> </tr> <tr> <td>Strong</td> <td>64 x cycle time</td> </tr> </tbody> </table>	Step	Time constant	None	1 x cycle time	Weak	4 x cycle time	Medium	32 x cycle time	Strong	64 x cycle time
Step	Time constant										
None	1 x cycle time										
Weak	4 x cycle time										
Medium	32 x cycle time										
Strong	64 x cycle time										
<sup>1</sup> Run-time calibration can be enabled during module parameter assignment to adjust for component drift due to changes in ambient temperature. During the calibration interval, the updating of new data is delayed by 250 ms. Calibration takes place each time the ambient temperature changes by 5 °C.											

## 4.8 2AI U High Speed analog electronic module (6ES7134-4FB51-0AB0)

### Properties

- 2 inputs for measuring voltage
- Input ranges:
  - ± 10 V, resolution 13 bits + sign
  - ± 5 V, resolution 13 bits + sign
  - ± 2.5 V, resolution 13 bits + sign
  - 1 to 5 V, resolution 13 bits
- Isolated from the load voltage L+
- Permissible common mode voltage 100 V<sub>ACSS</sub>
- Supports isochronous operation
  - Minimum time for the synchronous DP cycle (T<sub>DPmin</sub>): 2.5 ms
  - Minimum conversion time of the input modules (T<sub>WEmin</sub>): 1.1 ms

### General terminal assignment

---

#### Note

Terminals 4, 8, A4, A8, A3 and A7 are only available at specified terminal modules.

---

Terminal assignment for 2AI U High Speed (6ES7134-4FB51-0AB0)				
Terminal	Assignment	Terminal	Assignment	Notes
1	M <sub>0+</sub>	5	M <sub>1+</sub>	<ul style="list-style-type: none"> <li>• M<sub>n+</sub>: Input signal "+", channel n</li> <li>• M<sub>n-</sub>: Input signal "-", channel n</li> <li>• M<sub>ana</sub>: Ground of the module</li> <li>• n.c.: Not connected (max. DC 30 V can be connected)</li> <li>• AUX1: Protective-conductor terminal or potential bus (freely usable up to 230 VAC)</li> </ul>
2	M <sub>0-</sub>	6	M <sub>1-</sub>	
3	M <sub>ana</sub>	7	M <sub>ana</sub>	
4	n.c.	8	n.c.	
A4	AUX1	A8	AUX1	
A3	AUX1	A7	AUX1	

Usable terminal modules

Usable terminal modules for 2AI U High Speed (6ES7134-4FB51-0AB0)				
TM-E15C26-A1 (6ES7193-4CA50-0AA0)	TM-E15C24-A1 (6ES7193-4CA30-0AA0)	TM-E15C24-01 (6ES7193-4CB30-0AA0)	TM-E15C23-01 (6ES7193-4CB10-0AA0)	← Spring terminal
TM-E15S26-A1 (6ES7193-4CA40-0AA0)	TM-E15S24-A1 (6ES7193-4CA20-0AA0)	TM-E15S24-01 (6ES7193-4CB20-0AA0)	TM-E15S23-01 (6ES7193-4CB00-0AA0)	← Screw terminal
TM-E15N26-A1 (6ES7193-4CA80-0AA0)	TM-E15N24-A1 (6ES7193-4CA70-0AA0)	TM-E15N24-01 (6ES7193-4CB70-0AA0)	TM-E15N23-01 (6ES7193-4CB60-0AA0)	← Fast Connect
				<p>Wiring examples</p>

Block diagram

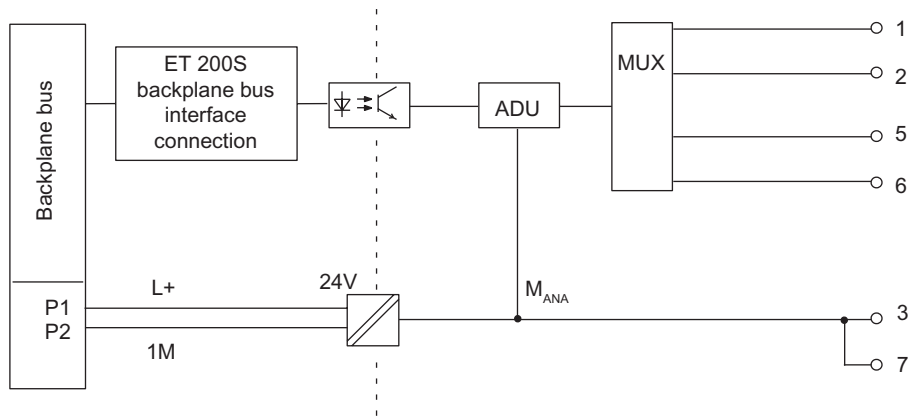

Figure 4-8 Block diagram of the 2AI U High Speed



## 2AI U High Speed Technical Specifications (6ES7134-4FB51-0AB0)

Dimensions and Weight	
Dimensions W × H × D (mm) (the total dimensions depend on the selected terminal module)	15 x 81 x 52
Weight	Approx. 40 g
Data for specific modules	
Supports isochronous operation	Yes
Number of inputs	2
Cable length	
• Shielded	max. 200 m
Parameter length	12 bytes (4 bytes when used as 6ES7134 4FB50-0AB0)
Voltages, currents, potentials	
Rated load voltage L+ (from the power module)	24 VDC
• Reverse polarity protection	Yes
Galvanic isolation	
• Between the channels and backplane bus	Yes
• Between the channels and load voltage L+	Yes
• Between the channels	no
Permissible potential difference	
• Between the inputs and M <sub>ANA</sub> (U <sub>CM</sub> )	100 VAC <sub>SS</sub>
• Between M <sub>ANA</sub> and the central grounding point (U <sub>ISO</sub> )	75 VDC / 60 VAC
Insulation tested	500 VDC
Current consumption	
• Power supply and load voltage L+ (no load)	max. 35 mA
Power dissipation of the module	Typically 0.8 W
Status, interrupts, diagnostics	
Interrupts	
• Hardware interrupt	Can be assigned parameters <sup>1</sup>
Diagnostics function	
• Group error display	Red "SF" LED
• Diagnostic information can be displayed	Possible <sup>2</sup>
Analog value generation	
Measuring principle	Instantaneous value encoding
Cycle time/resolution:	
• Conversion time in ms (per channel)	0.1
• Cycle time in ms (per module)	1
• Resolution (including overrange)	± 10 V/13 bits + sign ± 5 V/13 bits + sign ± 2.5 V/13 bits + sign 1 V to 5 V/13 bits

<b>Suppression of interference, limits of error</b>											
<ul style="list-style-type: none"> <li>Common mode interference (<math>U_{cm}</math>) &lt; 100 VSS)</li> </ul>	> 70 dB										
Crosstalk between the inputs	> 50 dB										
Operational limit (in the entire temperature range, with reference to the input range)	± 0.3%										
Basic error limit (operational limit at 25° C with reference to input range)	± 0.2%										
Temperature error (with reference to the input range)	± 0.01 %/K										
Linearity error (with reference to the input range)	± 0.01%										
Repeatability (in steady state at 25° C with reference to input range)	± 0.05%										
<b>Data for selecting a sensor</b>											
Input ranges (rated value)/input resistance											
<ul style="list-style-type: none"> <li>Voltage</li> </ul>	± 10 V/min. 100 kΩ ± 5 V/min. 100 kΩ ± 2.5 V/min. 100 kΩ 1 V - 5 V/min. 100 kΩ										
Maximum input voltage for voltage input (destruction limit)	50 V continuous, 100 V at max. duration of 1 ms (sampling ratio 1:20)										
Connection of the sensors											
<ul style="list-style-type: none"> <li>For measuring voltage</li> </ul>	supported										
Smoothing of the measured values	Yes, can be assigned parameters in 4 steps by means of digital filtering										
	<table border="1" style="width: 100%;"> <thead> <tr> <th style="text-align: left;"><b>Step</b></th> <th style="text-align: left;"><b>Time constant</b></th> </tr> </thead> <tbody> <tr> <td>None</td> <td>1 x cycle time</td> </tr> <tr> <td>Weak</td> <td>64 x cycle time</td> </tr> <tr> <td>Medium</td> <td>128 x cycle time</td> </tr> <tr> <td>Strong</td> <td>512 x cycle time</td> </tr> </tbody> </table>	<b>Step</b>	<b>Time constant</b>	None	1 x cycle time	Weak	64 x cycle time	Medium	128 x cycle time	Strong	512 x cycle time
<b>Step</b>	<b>Time constant</b>										
None	1 x cycle time										
Weak	64 x cycle time										
Medium	128 x cycle time										
Strong	512 x cycle time										
<sup>1</sup> DPV1 only <sup>2</sup> Parameter assignment error Violation of lower limit value Violation of upper limit value Open circuit (only with 1 V to 5 V) Process interrupt lost											

## 4.9 2AI I 2WIRE Standard analog electronic module (6ES7134-4GB01-0AB0)

### Properties

- 2 inputs for measuring current
- Input range:  
4 to 20 mA, resolution 13 bits

### General terminal assignment

---

#### Note

Terminals 4, 8, A4, A8, A3 and A7 are only available at specified terminal modules.

---

Terminal assignment for 2AI I 2WIRE Standard (6ES7134-4GB01-0AB0)				
Terminal	Assignment	Terminal	Assignment	Notes
1	M <sub>0+</sub>	5	M <sub>1+</sub>	<ul style="list-style-type: none"> <li>• M<sub>n+</sub>: Input signal "+", channel n</li> <li>• M<sub>n-</sub>: Input signal "-", channel n</li> <li>• M<sub>ana</sub>: Ground (of power module)</li> <li>• n.c.: Not connected (max. DC 30 V can be connected)</li> <li>• AUX1: Protective-conductor terminal or potential bus (freely usable up to 230 VAC)</li> </ul>
2	M <sub>0-</sub>	6	M <sub>1-</sub>	
3	M <sub>ana</sub>	7	M <sub>ana</sub>	
4	n.c.	8	n.c.	
A4	AUX1	A8	AUX1	
A3	AUX1	A7	AUX1	

Usable terminal modules

Usable terminal modules for 2AI   2WIRE Standard (6ES7134-4GB01-0AB0)				
TM-E15C26-A1 (6ES7193-4CA50-0AA0)	TM-E15C24-A1 (6ES7193-4CA30-0AA0)	TM-E15C24-01 (6ES7193-4CB30-0AA0)	TM-E15C23-01 (6ES7193-4CB10-0AA0)	← Spring terminal
TM-E15S26-A1 (6ES7193-4CA40-0AA0)	TM-E15S24-A1 (6ES7193-4CA20-0AA0)	TM-E15S24-01 (6ES7193-4CB20-0AA0)	TM-E15S23-01 (6ES7193-4CB00-0AA0)	← Screw terminal
TM-E15N26-A1 (6ES7193-4CA80-0AA0)	TM-E15N24-A1 (6ES7193-4CA70-0AA0)	TM-E15N24-01 (6ES7193-4CB70-0AA0)	TM-E15N23-01 (6ES7193-4CB60-0AA0)	← Fast Connect
				<p>Wiring examples</p> <p>2-wire measuring transducer is supplied by means of the measuring circuits.</p>

Block diagram

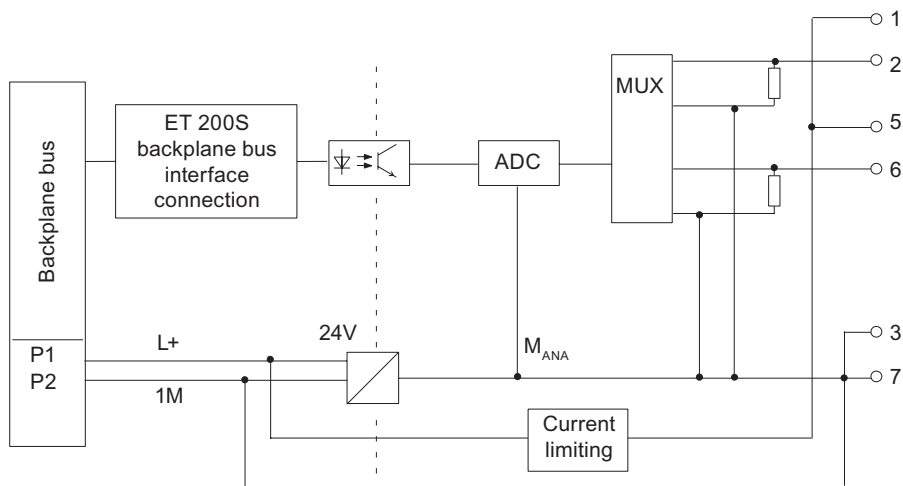

Figure 4-9 Block diagram of the 2AI | 2WIRE Standard

## 2AI I 2WIRE Standard Technical Specifications (6ES7134-4GB01-0AB0)

Dimensions and Weight		
Dimensions W × H × D (mm) (the total dimensions depend on the selected terminal module)	15 x 81 x 52	
Weight	Approx. 40 g	
Data for specific modules		
Supports isochronous operation	no	
Number of inputs	2	
Cable length		
• Shielded	max. 200 m	
Parameter length	4 bytes	
Voltages, currents, potentials		
Rated load voltage L+ (from the power module)	24 VDC	
• Reverse polarity protection	Yes	
Power supply of the transmitters	Yes	
• Short-circuit protection	Yes, (destruction limit 35 mA per channel)	
Galvanic isolation		
• Between the channels and backplane bus	Yes	
• Between the channels and load voltage L+	no	
• Between the channels	no	
Insulation tested	500 VDC	
Current consumption		
• From load voltage L+	max. 80 mA	
Power dissipation of the module	Typically 0.6 W	
Status, interrupts, diagnostics		
Diagnostics function		
• Group error	Red "SF" LED	
• Diagnostic functions readable	Yes	
Analog value generation		
Measuring principle	Integrative	
Integration and cycle time/resolution per channel:		
• Integration time can be assigned parameters	Yes	
• Interference frequency suppression in Hz	60	50
• Integration time in milliseconds	16.7	20
• Conversion time in ms	55	65
• Cycle time in ms	Number of active channels per module x conversion time	
• Resolution (including overrange)	4 mA to 20 mA/13 bits	

<b>Suppression of interference, limits of error</b>											
Interference voltage suppression for $f = n \times (f_1 \pm 1 \%)$ , ( $f_1 =$ interference frequency)											
<ul style="list-style-type: none"> <li>Common mode interference (peak value of interference &lt; rated value of input range)</li> </ul>	min. 70 dB										
Crosstalk between the inputs	min. -50 dB										
Operational limit (in the entire temperature range, with reference to the input range)	$\pm 0.6\%$										
Basic error limit (operational limit at 25° C with reference to input range)	$\pm 0.4\%$										
Temperature error (with reference to the input range)	$\pm 0.005 \%/K$										
Linearity error (with reference to the input range)	$\pm 0.01\%$										
Repeatability (in steady state at 25° C with reference to input range)	$\pm 0.05\%$										
<b>Data for selecting a sensor</b>											
Input range (rated value)/input resistance											
<ul style="list-style-type: none"> <li>Current</li> </ul>	4 mA to 20 mA/50 $\Omega$										
Permitted input current (destruction limit)	40 mA										
Load of the two-wire measuring transducer	max. 750 $\Omega$										
Smoothing of the measured values	Yes, can be assigned parameters in 4 steps by means of digital filtering										
	<table border="1" style="width: 100%;"> <thead> <tr> <th style="text-align: left;"><b>Step</b></th> <th style="text-align: left;"><b>Time constant</b></th> </tr> </thead> <tbody> <tr> <td>None</td> <td>1 x cycle time</td> </tr> <tr> <td>Weak</td> <td>4 x cycle time</td> </tr> <tr> <td>Medium</td> <td>32 x cycle time</td> </tr> <tr> <td>Strong</td> <td>64 x cycle time</td> </tr> </tbody> </table>	<b>Step</b>	<b>Time constant</b>	None	1 x cycle time	Weak	4 x cycle time	Medium	32 x cycle time	Strong	64 x cycle time
<b>Step</b>	<b>Time constant</b>										
None	1 x cycle time										
Weak	4 x cycle time										
Medium	32 x cycle time										
Strong	64 x cycle time										

## 4.10 4AI I 2WIRE Standard analog electronic module (6ES7134-4GD00-0AB0)

### Properties

- 4 inputs for measuring current
- Input range:  
4 to 20 mA, resolution 13 bits

### General terminal assignment

---

#### Note

Terminals 4, 8, A4, A8, A3 and A7 are only available at specified terminal modules.

---

Terminal assignment for 4AI I 2WIRE Standard (6ES7134-4GD00-0AB0)				
Terminal	Assignment	Terminal	Assignment	Notes
1	M <sub>0+</sub>	5	M <sub>1+</sub>	<ul style="list-style-type: none"> <li>• M<sub>n+</sub>: Input signal "+", channel n</li> <li>• M<sub>n-</sub>: Input signal "-", channel n</li> <li>• AUX1: Protective-conductor terminal or potential bus (freely usable up to 230 VAC)</li> </ul>
2	M <sub>0-</sub>	6	M <sub>1-</sub>	
3	M <sub>2+</sub>	7	M <sub>3+</sub>	
4	M <sub>2-</sub>	8	M <sub>3-</sub>	
A4	AUX1	A8	AUX1	
A3	AUX1	A7	AUX1	

Usable terminal modules

Usable terminal modules for 4AI I 2WIRE Standard (6ES7134-4GD00-0AB0)		
TM-E15C26-A1 (6ES7193-4CA50-0A A0)	TM-E15C24-01 (6ES7193-4CB30-0A A0)	← Spring terminal
TM-E15S26-A1 (6ES7193-4CA40-0A A0)	TM-E15S24-01 (6ES7193-4CB20-0A A0)	← Screw terminal
TM-E15N26-A1 (6ES7193-4CA80-0A A0)	TM-E15N24-01 (6ES7193-4CB70-0A A0)	← Fast Connect
		<p>Wiring examples</p> <p>2-wire measuring transducer is supplied by means of the measuring circuits.</p>

Block diagram

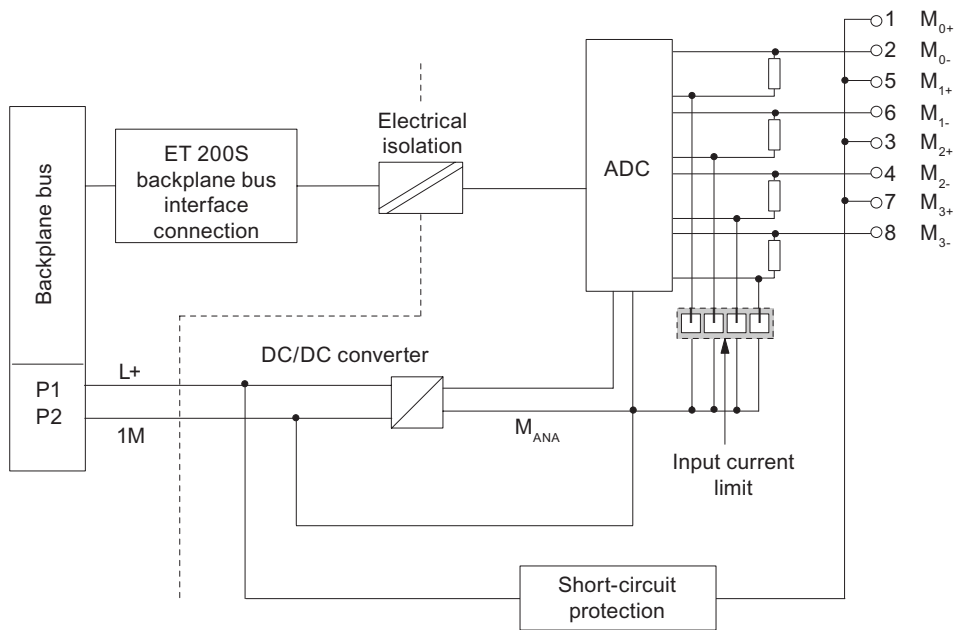

Figure 4-10 Block diagram of the 4AI I 2WIRE Standard



## 4AI I 2WIRE Standard Technical Specifications (6ES7134-4GD00-0AB0)

Dimensions and Weight		
Dimensions W × H × D (mm) (the total dimensions depend on the selected terminal module)	15 × 81 × 52	
Weight	Approx. 40 g	
Data for specific modules		
Supports isochronous operation	no	
Number of inputs	4	
Cable length		
• Shielded	max. 200 m	
Parameter length	7 bytes	
Voltages, currents, potentials		
Rated load voltage L+ (from the power module)	24 VDC	
• Reverse polarity protection	Yes	
Power supply of the transmitters	Yes	
• Short-circuit protection	Yes (approx. 200 mA for module)	
Galvanic isolation		
• Between the channels and backplane bus	Yes	
• Between the channels and load voltage L+	no	
• Between the channels	no	
Insulation tested	500 VDC	
Current consumption of the module		
• From the load voltage L+ (with sensor supply)	max. 125 mA	
Power dissipation of the module	Typically 0.6 W	
Status, interrupts, diagnostics		
Diagnostics function		
• Group error	Red "SF" LED	
• Diagnostic functions readable	Yes	
Analog value generation		
Measuring principle	Integrative	
Integration and cycle time/resolution per channel:		
• Integration time can be assigned parameters	Yes	
• Interference frequency suppression in Hz	60	50
• Integration time in milliseconds	16.7	20
• Cycle time per module in ms	33	40
• Resolution (including overrange)	4 mA to 20 mA/13 bits	

<b>Suppression of interference, limits of error</b>											
Interference voltage suppression for $f = n \times (f1 \pm 1\%)$ , ( $f1 =$ interference frequency)											
<ul style="list-style-type: none"> <li>Common mode interference (peak value of interference &lt; rated value of input range)</li> </ul>	min. 70 dB										
Crosstalk between the inputs	min. -50 dB										
Operational limit (in the entire temperature range, with reference to the input range)	$\pm 0.4\%$										
Basic error limit (operational limit at 25° C with reference to input range)	$\pm 0.3\%$										
Temperature error (with reference to the input range)	$\pm 0.003 \% / K$										
Linearity error (with reference to the input range)	$\pm 0.01\%$										
Repeatability (in steady state at 25° C with reference to input range)	$\pm 0.05\%$										
<b>Data for selecting a sensor</b>											
Input range (rated value)/input resistance											
<ul style="list-style-type: none"> <li>Current</li> </ul>	4 mA to 20 mA/25 $\Omega$										
Permitted input current (destruction limit)	Approx. 30 mA (limited electronically)										
Load of the two-wire measuring transducer	max. 750 $\Omega$										
Smoothing of the measured values	Yes, can be assigned parameters in 4 steps										
	<table border="1" style="width: 100%;"> <thead> <tr> <th style="text-align: left;"><b>Step</b></th> <th style="text-align: left;"><b>Time constant</b></th> </tr> </thead> <tbody> <tr> <td>None</td> <td>1 x cycle time</td> </tr> <tr> <td>Weak</td> <td>4 x cycle time</td> </tr> <tr> <td>Medium</td> <td>16 x cycle time</td> </tr> <tr> <td>Strong</td> <td>32 x cycle time</td> </tr> </tbody> </table>	<b>Step</b>	<b>Time constant</b>	None	1 x cycle time	Weak	4 x cycle time	Medium	16 x cycle time	Strong	32 x cycle time
<b>Step</b>	<b>Time constant</b>										
None	1 x cycle time										
Weak	4 x cycle time										
Medium	16 x cycle time										
Strong	32 x cycle time										

## 4.11 2AI I 2WIRE High Speed analog electronic module (6ES7134-4GB51-0AB0)

### Properties

- 2 inputs for measuring current
- Current-limited sensor supply (90 mA)
- Input ranges:
  - 4 to 20 mA, resolution 13 bits
  - 0 to 20 mA, resolution 13 bits
- Supports isochronous operation
  - Minimum time for the synchronous DP cycle ( $T_{DPmin}$ ): 2.5 ms
  - Minimum conversion time of the input modules ( $T_{WEmin}$ ): 1.1 ms

### General terminal assignment

---

#### Note

Terminals 4, 8, A4, A8, A3 and A7 are only available at specified terminal modules.

---

Terminal assignment for 2AI I 2WIRE High Speed (6ES7134-4GB51-0AB0)

Terminal	Assignment	Terminal	Assignment	Notes
1	M <sub>0+</sub>	5	M <sub>1+</sub>	<ul style="list-style-type: none"> <li>• M<sub>n+</sub>: Input signal "+", channel n</li> <li>• M<sub>n-</sub>: Input signal "-", channel n</li> <li>• M<sub>ana</sub>: Ground (of power module)</li> <li>• n.c.: Not connected (max. DC 30 V can be connected)</li> <li>• AUX1: Protective-conductor terminal or potential bus (freely usable up to 230 VAC)</li> </ul>
2	M <sub>0-</sub>	6	M <sub>1-</sub>	
3	M <sub>ana</sub>	7	M <sub>ana</sub>	
4	n.c.	8	n.c.	
A4	AUX1	A8	AUX1	
A3	AUX1	A7	AUX1	

Usable terminal modules

Usable terminal modules for 2AI I 2WIRE High Speed (6ES7134-4GB51-0AB0)				
TM-E15C26-A1 (6ES7193-4CA50-0AA0)	TM-E15C24-A1 (6ES7193-4CA30-0AA0)	TM-E15C24-01 (6ES7193-4CB30-0AA0)	TM-E15C23-01 (6ES7193-4CB10-0AA0)	← Spring terminal
TM-E15S26-A1 (6ES7193-4CA40-0AA0)	TM-E15S24-A1 (6ES7193-4CA20-0AA0)	TM-E15S24-01 (6ES7193-4CB20-0AA0)	TM-E15S23-01 (6ES7193-4CB00-0AA0)	← Screw terminal
TM-E15N26-A1 (6ES7193-4CA80-0AA0)	TM-E15N24-A1 (6ES7193-4CA70-0AA0)	TM-E15N24-01 (6ES7193-4CB70-0AA0)	TM-E15N23-01 (6ES7193-4CB60-0AA0)	← Fast Connect
				<p>Wiring examples</p> <p>2-wire measuring transducer is supplied by means of the measuring circuits.</p>

Block diagram

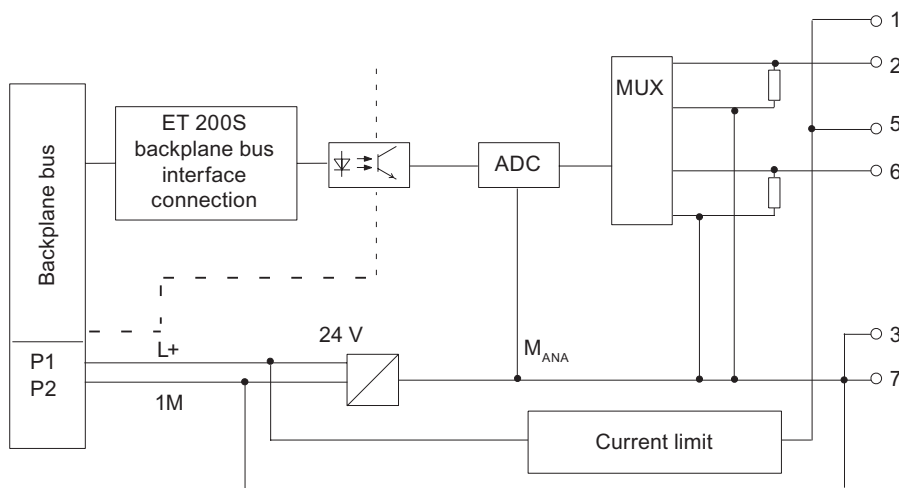

Figure 4-11 Block diagram of the 2AI I 2WIRE High Speed

## 2AI I 2WIRE High Speed Technical Specifications (6ES7134-4GB51-0AB0)

Dimensions and Weight	
Dimensions W x H x D (mm) (the total dimensions depend on the selected terminal module)	15 x 81 x 52
Weight	Approx. 40 g
Data for specific modules	
Supports isochronous operation	Yes
Number of inputs	2
Cable length	
• Shielded	max. 200 m
Parameter length	12 bytes (4 bytes when used as 6ES7134 4GB50 0AB0)
Voltages, currents, potentials	
Rated load voltage L+ (from the power module)	24 VDC
• Reverse polarity protection	Yes
• Short-circuit protection	Yes, (destruction limit 35 mA per channel)
Galvanic isolation	
• Between channels and backplane bus	Yes
• Between channels and load voltage L+	no
• Between the channels	no
Permissible potential difference	
• Between M <sub>ANA</sub> and M <sub>internal</sub> (U <sub>ISO</sub> )	75 VDC, 60 VAC
Insulation test voltage	500 VDC
Current consumption	
• Supply and load voltage L+	max. 35 mA <sup>1</sup>
Power dissipation of the module	Typically 0.8 W
Status, interrupts, diagnostics	
Interrupts	
• Hardware interrupt	Can be assigned parameters <sup>2</sup>
Diagnostics function	
• Group error display	Red "SF" LED
• Diagnostic functions readable	Possible <sup>3</sup>
Analog value generation	
Measuring principle	Instantaneous value encoding
Cycle time/resolution:	
• Conversion time in ms (per channel)	0.1
• Cycle time in ms (per module)	1
• Resolution (including overrange)	4 mA to 20 mA/13 bits 0 mA to 20 mA/13 bits

<b>Suppression of interference, limits of error</b>											
Crosstalk between the inputs	> 50 dB										
Operational limit (in the entire temperature range, with reference to the input range)	±0.3%										
Basic error limit (operational limit at 25° C with reference to input range)	± 0.2%										
Temperature error (with reference to the input range)	± 0.01 %/K										
Linearity error (with reference to the input range)	± 0.01%										
Repeatability (in steady state at 25° C with reference to input range)	± 0.05%										
<b>Sensor power supply outputs</b>											
Number of outputs	2										
Output voltage • With load	L+ (-2.5 V)										
Output current • Rated value • Permitted range	90 mA (both channels) 0 mA to 90 mA										
Short-circuit protection	Yes, electronic										
<b>Data for selecting a sensor</b>											
Input range (rated value/input resistance)											
• Current	4 mA to 20 mA/50 Ω 0 mA to 20 mA/50 Ω										
Connection of the sensors											
• For current measurement as two-wire transmitter	supported										
Load of the two-wire measuring transducer	max. 670 Ω										
Permitted input current (destruction limit)	60 mA										
Smoothing of the measured values	Yes, can be assigned parameters in 4 steps by means of digital filtering										
	<table border="1" style="width: 100%; border-collapse: collapse;"> <thead> <tr> <th style="text-align: left;">Step</th> <th style="text-align: left;">Time constant</th> </tr> </thead> <tbody> <tr> <td>None</td> <td>1 x cycle time</td> </tr> <tr> <td>Weak</td> <td>64 x cycle time</td> </tr> <tr> <td>Medium</td> <td>128 x cycle time</td> </tr> <tr> <td>Strong</td> <td>512 x cycle time</td> </tr> </tbody> </table>	Step	Time constant	None	1 x cycle time	Weak	64 x cycle time	Medium	128 x cycle time	Strong	512 x cycle time
Step	Time constant										
None	1 x cycle time										
Weak	64 x cycle time										
Medium	128 x cycle time										
Strong	512 x cycle time										
<sup>1</sup> Without encoder supply voltage <sup>2</sup> DPV1 only <sup>3</sup> Parameter assignment error Violation of lower limit value Violation of upper limit value Open circuit (only with 4 mA to 20 mA) Process interrupt lost											

## 4.12 2AI I 4WIRE Standard analog electronic module (6ES7134-4GB11-0AB0)

### Properties

- 2 inputs for measuring current
- Input ranges:
  - $\pm 20$  mA, resolution 13 bits + sign
  - 4 to 20 mA, resolution 13 bits
- Permissible common mode voltage  $2 \text{ VAC}_{SS}$

### General terminal assignment

---

#### Note

Terminals 4, 8, A4, A8, A3 and A7 are only available at specified terminal modules.

---

Terminal assignment for 2AI I 4WIRE Standard (6ES7134-4GB11-0AB0)				
Terminal	Assignment	Terminal	Assignment	Notes
1	M <sub>0+</sub>	5	M <sub>1+</sub>	<ul style="list-style-type: none"> <li>• M<sub>n+</sub>: Input signal "+", channel n</li> <li>• M<sub>n-</sub>: Input signal "-", channel n</li> <li>• L+ Power supply for four-wire measuring transducer</li> <li>• M<sub>ana</sub>: Ground (of power module)</li> <li>• AUX1: Protective-conductor terminal or potential bus (freely usable up to 230 VAC)</li> </ul>
2	M <sub>0-</sub>	6	M <sub>1-</sub>	
3	L+	7	L+	
4	M <sub>ana</sub>	8	M <sub>ana</sub>	
A4	AUX1	A8	AUX1	
A3	AUX1	A7	AUX1	

Usable terminal modules

Usable terminal modules for 2AI I 4WIRE Standard (6ES7134-4GB11-0AB0)		
TM-E15C26-A1 (6ES7193-4CA50-0AA0)	TM-E15C24-01 (6ES7193-4CB30-0AA0)	← Spring terminal
TM-E15S26-A1 (6ES7193-4CA40-0AA0)	TM-E15S24-01 (6ES7193-4CB20-0AA0)	← Screw terminal
TM-E15N26-A1 (6ES7193-4CA80-0AA0)	TM-E15N24-01 (6ES7193-4CB70-0AA0)	← Fast Connect
<p>The diagram shows three terminal layouts. The first two are standard 8-pin modules with terminals 1-4 and A0. The third is a module with terminals 1-4, A0, and AUX1. To the right, a 'Sample connection' diagram shows a 4-wire current measurement circuit with terminals M+, M-, L+, and M<sub>ana</sub>.</p>		

Block diagram

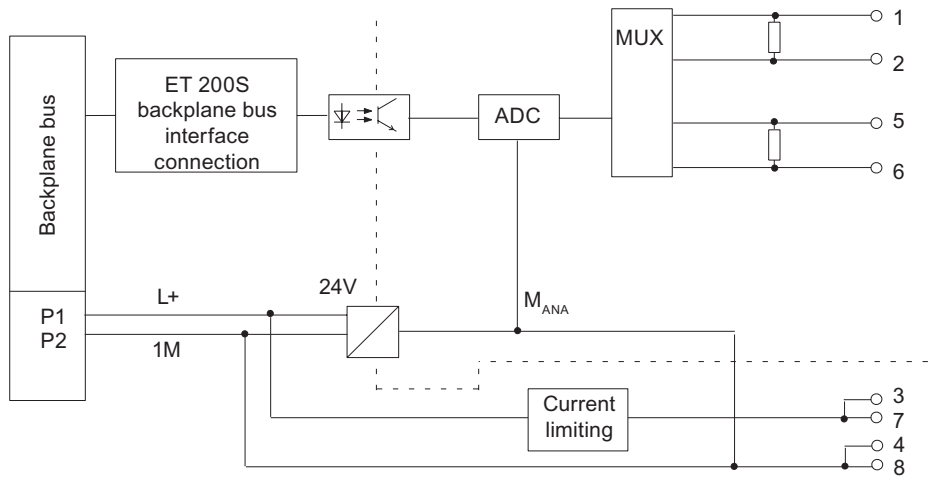

Figure 4-12 Block diagram of the 2AI I 4WIRE Standard



## 2AI I 4WIRE Standard Technical Specifications (6ES7134-4GB11-0AB0)

Dimensions and Weight	
Dimensions W × H × D (mm) (the total dimensions depend on the selected terminal module)	15 x 81 x 52
Weight	Approx. 40 g
Data for specific modules	
Supports isochronous operation	no
Number of inputs	2
Cable length	
• Shielded	max. 200 m
Parameter length	4 bytes
Voltages, currents, potentials	
Rated load voltage L+ (from the power module)	24 VDC
• Reverse polarity protection	Yes
Power supply of the transmitters	Yes
• Short-circuit protection	Yes, 60 mA (for both channels)
Galvanic isolation	
• Between the channels and backplane bus	Yes
• Between the channels and load voltage L+	no
• Between the channels	no
Insulation tested	500 VDC
Current consumption	
• From load voltage L+	max. 30 mA
Power dissipation of the module	Typically 0.6 W
Status, interrupts, diagnostics	
Diagnostics function	
• Group error	Red "SF" LED
• Diagnostic functions readable	Yes
Analog value generation	
Measuring principle	Integrative
Integration and cycle time/resolution per channel:	
• Integration time can be assigned parameters	Yes
• Interference frequency suppression in Hz	60                      50
• Integration time in milliseconds	16.7                      20
• Conversion time in ms	55                         65
• Cycle time in ms	Number of active channels per module x conversion time
• Resolution (including overrange)	± 20 mA/13 bits + sign 4 mA to 20 mA/13 bits

<b>Suppression of interference, limits of error</b>											
Interference voltage suppression for $f = n \times (f1 \pm 1 \%)$ , ( $f1 =$ interference frequency)											
<ul style="list-style-type: none"> <li>Common mode interference (peak value of interference &lt; rated value of input range)</li> </ul>	min. 70 dB										
Crosstalk between the inputs	min. - 50 dB										
Operational limit (in the entire temperature range, with reference to the input range)	$\pm 0.6\%$										
Basic error limit (operational limit at 25° C with reference to input range)	$\pm 0.4\%$										
Temperature error (with reference to the input range)	$\pm 0.005 \%/K$										
Linearity error (with reference to the input range)	$\pm 0.01\%$										
Repeatability (in steady state at 25° C with reference to input range)	$\pm 0.05\%$										
<b>Data for selecting a sensor</b>											
Input range (rated value)/input resistance											
<ul style="list-style-type: none"> <li>Current</li> </ul>	$\pm 20 \text{ mA}/50 \Omega$ 4 mA to 20 mA/50 $\Omega$										
Permitted input current (destruction limit)	40 mA										
Smoothing of the measured values	Yes, can be assigned parameters in 4 steps by means of digital filtering										
	<table border="1" style="width: 100%;"> <thead> <tr> <th style="text-align: left;"><b>Step</b></th> <th style="text-align: left;"><b>Time constant</b></th> </tr> </thead> <tbody> <tr> <td>None</td> <td>1 x cycle time</td> </tr> <tr> <td>Weak</td> <td>4 x cycle time</td> </tr> <tr> <td>Medium</td> <td>32 x cycle time</td> </tr> <tr> <td>Strong</td> <td>64 x cycle time</td> </tr> </tbody> </table>	<b>Step</b>	<b>Time constant</b>	None	1 x cycle time	Weak	4 x cycle time	Medium	32 x cycle time	Strong	64 x cycle time
<b>Step</b>	<b>Time constant</b>										
None	1 x cycle time										
Weak	4 x cycle time										
Medium	32 x cycle time										
Strong	64 x cycle time										

## 4.13 2AI I 2/4WIRE High Feature analog electronic module (6ES7134-4MB00-0AB0)

### Properties

- 2 inputs for measuring current
- Input ranges:
  - $\pm 20$  mA, resolution 15 bits + sign
  - 4 to 20 mA, resolution 15 bits
- Isolated from the load voltage L+
- Permitted common-mode voltage between the channels 100 VAC
- Supports two-wire or four-wire measuring transducers

### General terminal assignment

#### Note

Terminals 4, 8, A4, A8, A3 and A7 are only available at specified terminal modules.

Terminal assignment for 2AI I 2/4WIRE High Feature (6ES7134-4MB00-0AB0)				
Terminal	Assignment	Terminal	Assignment	Notes
1	M <sub>0+</sub>	5	M <sub>1+</sub>	<b>2-wire transducer:</b> <ul style="list-style-type: none"> <li>• M<sub>n+</sub>: Input signal "-", channel n</li> <li>• M<sub>n-</sub>: connect to L-</li> <li>• L+ Input signal "+", channel n</li> <li>• AUX1: Protective-conductor terminal or potential bus (freely usable up to 230 VAC)</li> </ul> <b>4-wire transducer:</b> <ul style="list-style-type: none"> <li>• M<sub>n+</sub>: Input signal "+", channel n</li> <li>• M<sub>n-</sub>: Input signal "-", channel n</li> <li>• L+ Power supply for four-wire measuring transducer</li> <li>• L-: Return circuit for measuring transducer supply</li> <li>• AUX1: Protective-conductor terminal or potential bus (freely usable up to 230 VAC)</li> </ul>
2	M <sub>0-</sub>	6	M <sub>1-</sub>	
3	L+	7	L+	
4	L-	8	L-	
A4	AUX1	A8	AUX1	
A3	AUX1	A7	AUX1	

Usable terminal modules

Usable terminal modules for 2AI I 2/4WIRE High Feature (6ES7134-4MB00-0AB0)		
TM-E15C26-A1 (6ES7193-4CA50-0AA0)	TM-E15C24-01 (6ES7193-4CB30-0AA0)	← Spring terminal
TM-E15S26-A1 (6ES7193-4CA40-0AA0)	TM-E15S24-01 (6ES7193-4CB20-0AA0)	← Screw terminal
TM-E15N26-A1 (6ES7193-4CA80-0AA0)	TM-E15N24-01 (6ES7193-4CB70-0AA0)	← Fast Connect
<p>The diagram shows two terminal layouts for 26-pin modules. The left layout shows terminals 1-8 and AUX1 with connections for a 2-wire transducer (M+, M-, L+, L-) and a 4-wire transducer (mA). The right layout shows terminals 1-8 with connections for a 2-wire transducer (M+, M-, L+, L-) and a 4-wire transducer (mA). Below the layouts is a 'Wiring examples' section with two circuit diagrams: a 2-wire transducer circuit with terminals M+, M-, L+, and L- connected to a mA meter, and a 4-wire transducer circuit with terminals 1, 2, 5, and 6 connected to a mA meter.</p>		

Block diagram

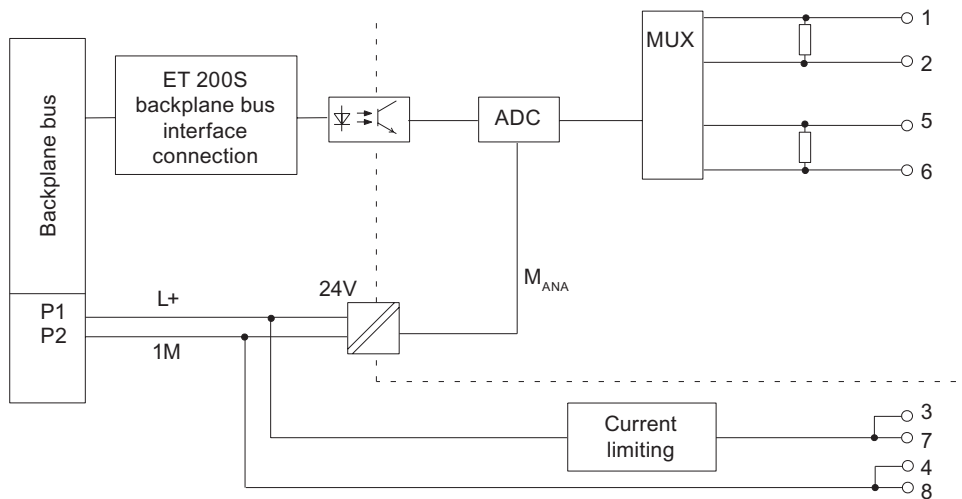

Figure 4-13 Block diagram of the 2AI I 2/4WIRE High Feature

## 2AI I 2/4WIRE High Feature Technical Specifications (6ES7134-4MB00-0AB0)

Dimensions and Weight			
Dimensions W × H × D (mm) (the total dimensions depend on the selected terminal module)	15 x 81 x 52		
Weight	Approx. 40 g		
Data for specific modules			
Supports isochronous operation	no		
Number of inputs	2		
Cable length			
• Shielded	max. 200 m		
Parameter length	4 bytes		
Voltages, currents, potentials			
Rated load voltage L+ (from the power module)	24 VDC		
• Reverse polarity protection	Yes		
Power supply of the transmitters	Yes		
• Short-circuit protection	Yes, 60 mA (for both channels)		
Galvanic isolation			
• Between the channels and backplane bus	Yes		
• Between the channels and load voltage L+	Yes		
• Between the channels and PE	Yes		
• Between the channels	no		
Permissible potential difference			
• Between the channels	140 VDC/100 VAC (with isolated power supply for the measuring transducer)		
Insulation tested	500 VDC		
Current consumption			
• From load voltage L+	max. 53 mA		
Power dissipation of the module	Typically 0.85 W		
Status, interrupts, diagnostics			
Diagnostics function			
• Group error	Red "SF" LED		
• Diagnostic functions readable	Yes		
Analog value generation			
Measuring principle	Integrative		
Integration and cycle time/resolution per channel:			
• Integration time can be assigned parameters	Yes		
• Interference frequency suppression in Hz	60	50	no
• Integration time in milliseconds	16.67	20	7.5
• Conversion time in ms			
– 1 channel active per module	25	30	10
– 2 channels active per module	58.3	70	26
• Cycle time in ms			
– 1 channel active per module	75	90	30
– 2 channels active per module	175	210	78
• Resolution (including overrange)	± 20 mA/15 bits + sign 4 mA to 20 mA/15 bits		

<b>Suppression of interference, limits of error</b>											
Interference voltage suppression for $f = n \times (f_1 \pm 0.5 \%)$ , ( $f_1$ = interference frequency)											
<ul style="list-style-type: none"> <li>• Common-mode interference (<math>U_{SS}</math>)</li> <li>• Series-mode interference (peak interference value &lt; rated value of input range)</li> </ul>	min. 100 dB min. 90 dB										
Crosstalk between the inputs	min. -100 dB										
Operational limit <sup>1</sup> (over the entire temperature range, with reference to the input range)	$\pm 0.1 \%$										
Basic error limit <sup>1</sup> operational limit at 25 °C with reference to input range	$\pm 0.05 \%$										
Temperature error (with reference to the input range)	$\pm 0.003 \%/K$										
Linearity error (with reference to the input range)	$\pm 0.03 \%$										
Repeatability (in steady state at 25° C with reference to input range)	$\pm 0.01 \%$										
<b>Data for selecting a sensor</b>											
Input range (rated value)/input resistance											
<ul style="list-style-type: none"> <li>• Current</li> </ul>	$\pm 20 \text{ mA}/50 \Omega$ $4 \text{ mA to } 20 \text{ mA}/50 \Omega$										
Permitted input current (destruction limit)	40 mA (on a single channel)										
Load of the two-wire measuring transducer	max. 750 $\Omega$										
Smoothing of the measured values	Yes, can be assigned parameters in 4 steps by means of digital filtering										
	<table border="1" style="width: 100%; border-collapse: collapse;"> <thead> <tr> <th style="text-align: left;">Step</th> <th style="text-align: left;">Time constant</th> </tr> </thead> <tbody> <tr> <td>None</td> <td>1 x cycle time</td> </tr> <tr> <td>Weak</td> <td>4 x cycle time</td> </tr> <tr> <td>Medium</td> <td>32 x cycle time</td> </tr> <tr> <td>Strong</td> <td>64 x cycle time</td> </tr> </tbody> </table>	Step	Time constant	None	1 x cycle time	Weak	4 x cycle time	Medium	32 x cycle time	Strong	64 x cycle time
Step	Time constant										
None	1 x cycle time										
Weak	4 x cycle time										
Medium	32 x cycle time										
Strong	64 x cycle time										
<sup>1</sup> Run-time calibration can be enabled during module parameter assignment to periodically adjust for the offset voltage drift of the A/D converter. During the calibration interval, the updating of new data is delayed by 200 ms. The accuracy limits of the module will be met without run-time calibration.											

## 4.14 2AI I 4WIRE High Speed analog electronic module (6ES7134-4GB61-0AB0)

### Properties

- 2 inputs for measuring current
- Current-limited sensor supply (90 mA)
- Input ranges:
  - 4 to 20 mA, resolution 13 bits
  - 0 to 20 mA, resolution 13 bits
  - $\pm 20$  mA, resolution 13 bits + sign
- Supports isochronous operation
  - Minimum time for the synchronous DP cycle ( $T_{DPmin}$ ): 2.5 ms
  - Minimum conversion time of the input modules ( $T_{WEmin}$ ): 1.1 ms

### General terminal assignment

#### Note

Terminals 4, 8, A4, A8, A3 and A7 are only available at specified terminal modules.

Terminal assignment for 2AI I 4WIRE High Speed (6ES7134-4GB61-0AB0)				
Terminal	Assignment	Terminal	Assignment	Notes
1	M <sub>0+</sub>	5	M <sub>1+</sub>	<ul style="list-style-type: none"> <li>• M<sub>n+</sub>: Input signal "+", channel n</li> <li>• M<sub>n-</sub>: Input signal "-", channel n</li> <li>• L+ Power supply for four-wire measuring transducer</li> <li>• M<sub>ana</sub>: Ground (of power module)</li> <li>• AUX1: Protective-conductor terminal or potential bus (freely usable up to 230 VAC)</li> </ul>
2	M <sub>0-</sub>	6	M <sub>1-</sub>	
3	L+	7	L+	
4	M <sub>ana</sub>	8	M <sub>ana</sub>	
A4	AUX1	A8	AUX1	
A3	AUX1	A7	AUX1	

Usable terminal modules

Usable terminal modules for 2AI I 4WIRE High Speed (6ES7134-4GB61-0AB0)		
TM-E15C26-A1 (6ES7193-4CA50-0AA0)	TM-E15C24-01 (6ES7193-4CB30-0AA0)	← Spring terminal
TM-E15S26-A1 (6ES7193-4CA40-0AA0)	TM-E15S24-01 (6ES7193-4CB20-0AA0)	← Screw terminal
TM-E15N26-A1 (6ES7193-4CA80-0AA0)	TM-E15N24-01 (6ES7193-4CB70-0AA0)	← Fast Connect
		<p>Sample connection</p>

Block diagram

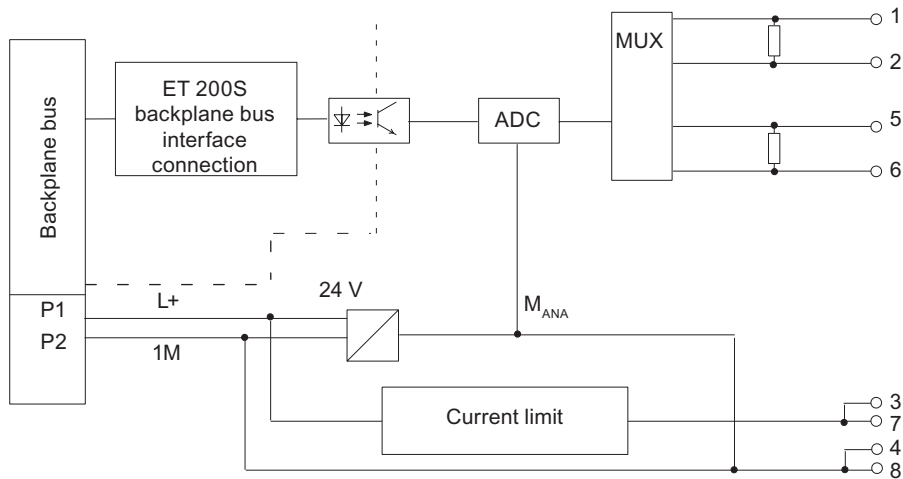

Figure 4-14 Block diagram of the 2AI I 4WIRE High Speed



## 2AI I 4WIRE High Speed Technical Specifications (6ES7134-4GB61-0AB0)

Dimensions and Weight	
Dimensions W × H × D (mm) (the total dimensions depend on the selected terminal module)	15 x 81 x 52
Weight	Approx. 40 g
Data for specific modules	
Supports isochronous operation	Yes
Number of inputs	2
Cable length	
• Shielded	max. 200 m
Parameter length	12 bytes (4 bytes when used as 6ES7134 4GB60 0AB0)
Voltages, currents, potentials	
Rated load voltage L+ (from the power module)	24 VDC
• Reverse polarity protection	Yes
Galvanic isolation	
• Between channels and backplane bus	Yes
• Between channels and load voltage L+	no
• Between the channels	no
Permissible potential difference	
• Between M <sub>ANA</sub> and M <sub>internal</sub> (U <sub>ISO</sub> )	75 VDC, 60 VAC
Insulation test voltage	500 VDC
Current consumption	
• Power supply and load voltage L+ (no load)	max. 35 mA <sup>1</sup>
Power dissipation of the module	Typically 0.8 W
Status, interrupts, diagnostics	
Interrupts	
• Hardware interrupt	Can be assigned parameters <sup>2</sup>
Diagnostics function	
• Group error display	Red "SF" LED
• Diagnostic information readable	Possible <sup>3</sup>
Analog value generation	
Measuring principle	Instantaneous value encoding
Cycle time/resolution:	
• Conversion time in ms (per channel)	0.1
• Cycle time in ms (per module)	1
• Resolution (including overrange)	4 mA to 20 mA/13 bit 0 mA to 20 mA/13 bit ± 20 mA/13 bits + sign

Suppression of interference, limits of error		
Crosstalk between the inputs	> 50 dB	
Operational limit (in the entire temperature range, with reference to the input range)	± 0.3 %	
Basic error limit (operational limit at 25 °C with reference to input range)	± 0.2 %	
Temperature error (with reference to the input range)	± 0.01 %/K	
Linearity error (with reference to the input range)	± 0.01 %	
Repeatability (in steady state at 25° C with reference to input range)	± 0.05 %	
Sensor power supply outputs		
Number of outputs	2	
Output voltage • With load	L+ (-2.5 V)	
Output current • Rated value • Permitted range	90 mA (both channels) 0 mA to 90 mA	
Short-circuit protection	Yes, electronic	
Data for selecting a sensor		
Input range (rated value)/input resistance • Current	4 mA to 20 mA/50 Ω 0 mA to 20 mA/50 Ω ± 20 mA/50 Ω	
Connection of the sensors • For current measurement as two-wire transmitter	supported	
Load of the two-wire measuring transducer	max. 670 Ω	
Maximum input current for current input (destruction limit)	60 mA	
Smoothing of the measured values	Yes, can be assigned parameters in 4 steps by means of digital filtering	
	<b>Step</b> None Weak Medium Strong	<b>Time constant</b> 1 x cycle time 64 x cycle time 128 x cycle time 512 x cycle time
<sup>1</sup> Without encoder supply voltage <sup>2</sup> DPV1 only <sup>3</sup> Parameter assignment error Violation of lower limit value Violation of upper limit value Open circuit (only with 4 mA to 20 mA) Process interrupt lost		

## 4.15 2AI RTD Standard analog electronic module (6ES7134-4JB50-0AB0)

### Properties

- 2 inputs for resistance thermometers or resistance measurement
- Input ranges:
  - Resistance thermometers: Pt100, Ni100; resolution 15 bits + sign
  - Resistance measurement: 150  $\Omega$ ; 300  $\Omega$  ; 600  $\Omega$ , resolution max. 15 bits + sign
- Isolated from the load voltage L+
- Linearization of the sensor characteristic curves

### General terminal assignment

---

#### Note

Terminals 4, 8, A4, A8, A3 and A7 are only available at specified terminal modules.

---

The resistance thermometers/resistors are measured in a four-wire connection. Constant current is fed to the resistance thermometers/resistors by means of connections  $I_{c+}$  and  $I_{c-}$ . The voltage measured at the resistance thermometer/resistor is measured at the connections  $M+$  and  $M-$ . This ensures highly accurate measurement results with the four-wire connection.

With the two/three-wire connection, you must apply corresponding jumpers to the module between  $M+$  and  $I_{c+}$  or  $M-$  and  $I_{c-}$ . However, you have to expect a loss of accuracy in the measurement results.

Terminal assignment for 2AI RTD Standard (6ES7134-4JB50-0AB0)

Terminal	Assignment	Terminal	Assignment	Notes
1	$M_{0+}$	5	$M_{1+}$	<ul style="list-style-type: none"> <li>• <math>M_{n+}</math>: Measuring line positive, channel n</li> <li>• <math>M_{n-}</math>: Measuring line negative, channel n</li> <li>• <math>I_{cn+}</math>: Constant current line positive, channel n</li> <li>• <math>I_{cn-}</math>: Measuring line negative, channel n</li> <li>• AUX1: Protective-conductor terminal or potential bus (freely usable up to 230 VAC)</li> </ul>
2	$M_{0-}$	6	$M_{1-}$	
3	$I_{c0+}$	7	$I_{c1+}$	
4	$I_{c0-}$	8	$I_{c1-}$	
A4	AUX1	A8	AUX1	
A3	AUX1	A7	AUX1	

Usable terminal modules

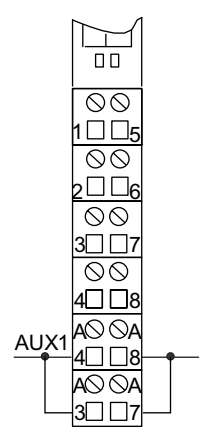
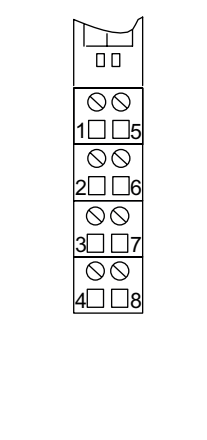
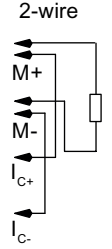
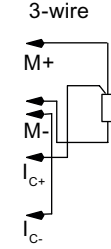
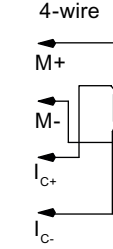
Usable terminal modules for 2AI RTD Standard (6ES7134-4JB50-0AB0)		
TM-E15C26-A1 (6ES7193-4CA50-0AA0)	TM-E15C24-01 (6ES7193-4CB30-0AA0)	← Spring terminal
TM-E15S26-A1 (6ES7193-4CA40-0AA0)	TM-E15S24-01 (6ES7193-4CB20-0AA0)	← Screw terminal
TM-E15N26-A1 (6ES7193-4CA80-0AA0)	TM-E15N24-01 (6ES7193-4CB70-0AA0)	← Fast Connect
<div style="display: flex; justify-content: space-around; align-items: flex-start;"> <div style="text-align: center;">  </div> <div style="text-align: center;">  </div> <div style="text-align: center;"> <p>Wiring examples</p> <div style="display: flex; justify-content: space-around;"> <div style="text-align: center;"> <p>2-wire</p>  </div> <div style="text-align: center;"> <p>3-wire</p>  </div> <div style="text-align: center;"> <p>4-wire</p>  </div> </div> </div> </div>		

**Note**

A wire break in the measuring lines of the temperature sensors for three- or four-wire connections (connections 1 and 2, or 5 and 6) is not detected. Undefined values can be reported.

Block diagram

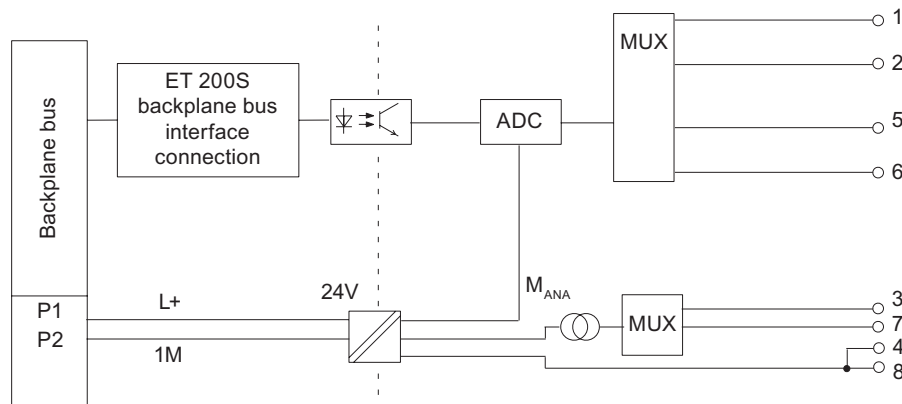

Figure 4-15 Block diagram of the 2AI RTD Standard

2AI RTD Standard Technical Specifications (6ES7134-4JB50-0AB0)

Dimensions and Weight	
Dimensions W × H × D (mm) (the total dimensions depend on the selected terminal module)	15 x 81 x 52
Weight	Approx. 40 g
Data for specific modules	
Supports isochronous operation	no
Number of inputs	2
Cable length	
• Shielded	max. 200 m
Parameter length	4 bytes
Voltages, currents, potentials	
Rated load voltage L+ (from the power module)	24 VDC
• Reverse polarity protection	Yes
Power supply of the transmitters	Yes
• Constant-current supply for resistance-type sensors	Approx. 1.5 mA
• Short-circuit protection	Yes
Galvanic isolation	
• Between the channels and backplane bus	Yes
• Between the channels and load voltage L+	Yes
• Between the channels	no
Permissible potential difference	
• Between M <sub>ANA</sub> and the central grounding point (U <sub>ISO</sub> )	75 VDC / 60 VAC

Insulation tested	500 VDC	
Current consumption		
• From load voltage L+	max. 30 mA	
Power dissipation of the module	Typically 0.6 W	
<b>Status, interrupts, diagnostics</b>		
Diagnostics function		
• Group error	Red "SF" LED	
• Diagnostic functions readable	Yes	
<b>Analog value generation</b>		
Measuring principle	Integrative	
Integration and cycle time/resolution per channel:		
• Integration time can be assigned parameters	Yes	
• Interference frequency suppression in Hz	60	50
• Integration time in milliseconds	16.7	20
• Conversion time in ms	110	130
• Cycle time in ms	Number of active channels per module x conversion time	
• Resolution (including overrange)	Pt100, Ni100/ 15 bits + sign 150 Ω/14 bits/ 300 Ω, 600 Ω/15 bits	
<b>Suppression of interference, limits of error</b>		
Interference voltage suppression for $f = n \times (f_1 \pm 1 \%)$ , ( $f_1 =$ interference frequency)		
• Common-mode interference ( $U_{SS}$ ) • Series-mode interference (peak interference value < rated value of input range)	min. 90 dB min. 70 dB	
Crosstalk between the inputs	min. -50 dB	
Operational limit (in the entire temperature range, with reference to the input range)	$\pm 0.6 \%$	
Basic error limit (operational limit at 25° C with reference to input range)	$\pm 0.4 \%$	
Temperature error (with reference to the input range)	$\pm 0.005 \%/K$	
Linearity error (with reference to the input range)	$\pm 0.01 \%$	
Repeatability (in steady state at 25° C with reference to input range)	$\pm 0.05 \%$	

Data for selecting a sensor		
Input range (rated value)/input resistance		
• Resistance-type sensor	150 $\Omega$ /min. 2 M $\Omega$ 300 $\Omega$ /min. 2 M $\Omega$ 600 $\Omega$ /min. 2 M $\Omega$	
• Resistance thermometer	Pt100/min. 2 M $\Omega$ Ni100/min. 2 M $\Omega$	
Permitted input voltage (destruction limit)	max. 9 V	
Connection of the sensors		
• For measuring resistance		
– Two and three-wire connection	Yes, line resistances are also measured, jumpers at T <sub>R</sub>	
– Four-wire connection	Yes	
Characteristic curve linearization	Yes, parameters can be assigned for Pt100, Ni100	
Smoothing of the measured values	Yes, can be assigned parameters in 4 steps by means of digital filtering	
	<b>Step</b>	<b>Time constant</b>
	None	1 x cycle time
	Weak	4 x cycle time
	Medium	64 x cycle time
	Strong	128 x cycle time

## 4.16 2AI RTD High Feature analog electronic module (6ES7134-4NB51-0AB0)

### Properties

- 2 inputs for resistance thermometers or resistance measurement
- Input ranges
  - Resistance thermometers: Pt100; Ni100; Ni120; Pt200; Ni200; Pt500; Ni500; Pt1000; Ni1000; Cu10; resolution max. 15 bits + sign
  - Resistance measurement: 150  $\Omega$ ; 300  $\Omega$ ; 600  $\Omega$ ; 3000  $\Omega$ ; PTC; resolution max. 15 bits
- Automatic compensation of line resistances in the case of a three-wire connection
- Temperature coefficient can be assigned parameters for resistance-type sensors
- High accuracy
- Isolated from the load voltage
- Linearization of the sensor characteristic curves
- Permitted common-mode voltage 5 VAC<sub>ss</sub>
- Recording of reference junction temperature (together with the 2AI TC Standard electronic module)
- Compatible with the 2AI RTD Standard (6ES7134-4JB50-0AB50)

**Note**

The 2AI RTD High Feature electronic module can replace a 2AI RTD Standard in an existing system.

- The wiring does not have to be changed. The additional bridges on the terminal module of the 2AI RTD Standard do not have to be removed.
- The configuration (in HW Config or the GSD file) does not have to be changed. Only the new functions of the 2AI RTD High Feature cannot be assigned parameters in this instance.

**General terminal assignment**

**Note**

Terminals 4, 8, A4, A8, A3 and A7 are only available at specified terminal modules.

Terminal assignment for 2AI RTD High Feature (6ES7134-4NB51-0AB0)				
Terminal	Assignment	Terminal	Assignment	Notes
1	M <sub>0+</sub>	5	M <sub>1+</sub>	<ul style="list-style-type: none"> <li>• M<sub>n+</sub>: Measuring line positive, channel n</li> <li>• M<sub>n-</sub>: Measuring line negative, channel n</li> <li>• I<sub>C0+</sub>: Constant current line positive, channel n</li> <li>• I<sub>C0-</sub>: Measuring line negative, channel n</li> <li>• AUX1: Protective-conductor terminal or potential bus (freely usable up to 230 VAC)</li> </ul>
2	M <sub>0-</sub>	6	M <sub>1-</sub>	
3	I <sub>C0+</sub>	7	I <sub>C1+</sub>	
4	I <sub>C0-</sub>	8	I <sub>C1-</sub>	
A4	AUX1	A8	AUX1	
A3	AUX1	A7	AUX1	



Usable terminal modules

Usable terminal modules for 2AI RTD High Feature (6ES7134-4NB51-0AB0)				
TM-E15C26-A1 (6ES7193-4CA50-0AA0)	TM-E15C24-A1 (6ES7193-4CA30-0AA0)	TM-E15C24-01 (6ES7193-4CB30-0AA0)	TM-E15C23-01 (6ES7193-4CB10-0AA0)	← Spring terminal
TM-E15S26-A1 (6ES7193-4CA40-0AA0)	TM-E15S24-A1 (6ES7193-4CA20-0AA0)	TM-E15S24-01 (6ES7193-4CB20-0AA0)	TM-E15S23-01 (6ES7193-4CB00-0AA0)	← Screw terminal
TM-E15N26-A1 (6ES7193-4CA80-0AA0)	TM-E15N24-A1 (6ES7193-4CA70-0AA0)	TM-E15N24-01 (6ES7193-4CB70-0AA0)	TM-E15N23-01 (6ES7193-4CB60-0AA0)	← Fast Connect

Block diagram

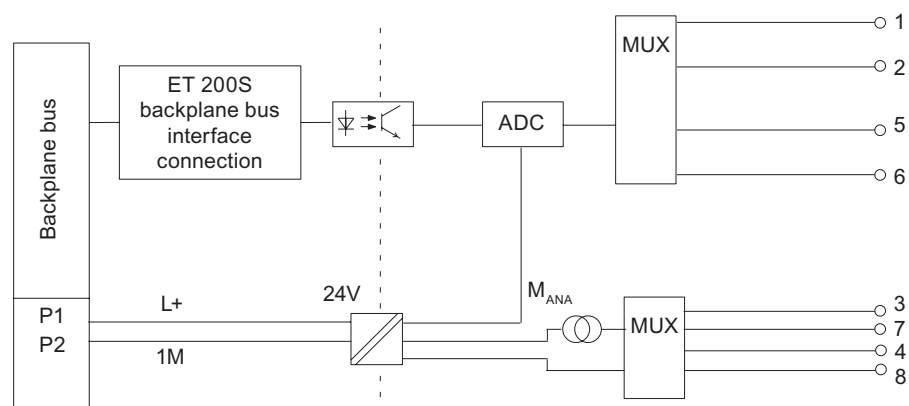

Figure 4-16 Block diagram of the 2AI RTD High Feature

**2AI RTD High Feature Technical Specifications (6ES7134-4NB51-0AB0)**

<b>Dimensions and Weight</b>	
Dimensions W × H × D (mm) (the total dimensions depend on the selected terminal module)	15 x 81 x 52
Weight	Approx. 40 g
<b>Data for specific modules</b>	
Supports isochronous operation	no
Number of inputs	2
Cable length	
• Shielded	max. 200 m
Parameter length	7 bytes (4 bytes when used as 2AI RTD Standard)
<b>Voltages, currents, potentials</b>	
Rated load voltage L+ (from the power module)	24 VDC
• Reverse polarity protection	Yes
Power supply of the transmitters	Yes
• Constant-current supply for resistance-type sensors	Approx. 1.25 mA
• Short-circuit protection	Yes
Galvanic isolation	
• Between the channels and backplane bus	Yes
• Between the channels and load voltage L+	Yes
• Between the channels	no
Permissible potential difference	
• Between M <sub>ANA</sub> and the central grounding point (U <sub>ISO</sub> )	75 VDC / 60 VAC
Insulation tested	500 VDC
Current consumption	
• From load voltage L+	max. 30 mA
Power dissipation of the module	Typically 0.6 W
<b>Status, interrupts, diagnostics</b>	
Diagnostics function	
• Group error	Red "SF" LED
• Diagnostic functions readable	Yes

## 4.16 2AI RTD High Feature analog electronic module (6ES7134-4NB51-0AB0)

Analog value generation		
Measuring principle	Integrating (sigma-delta)	
Integration and cycle time/resolution per channel:		
<ul style="list-style-type: none"> <li>Integration time can be assigned parameters</li> </ul>	Yes	
<ul style="list-style-type: none"> <li>Interference frequency suppression in Hz</li> </ul>	60	50
<ul style="list-style-type: none"> <li>Integration time in milliseconds</li> </ul>	16.7	20
<ul style="list-style-type: none"> <li>Basic conversion time incl. integration time in ms</li> </ul>	50	60
<ul style="list-style-type: none"> <li>Additional conversion time for wire break check diagnosis in ms</li> </ul>	5	5
<ul style="list-style-type: none"> <li>Additional conversion time in ms for line compensation in three-wire connections</li> </ul>	50	60
<ul style="list-style-type: none"> <li>Cycle time in ms</li> </ul>	Number of active channels per module x conversion time	
<ul style="list-style-type: none"> <li>Resolution (including overrange)</li> </ul>	Pt 100; Ni 100; Ni120; Pt 200; Ni 200; Pt 500; Ni 500; Pt 1000; Ni 1000; Cu 10 / 15 bits + sign 150 Ω; 300 Ω; 600 Ω; 3000 Ω; / 15 bits PTC <sup>1</sup> / 1 bit	
Suppression of interference, limits of error		
Interference voltage suppression for $f = n \times (f_1 \pm 1 \%)$ , ( $f_1 =$ interference frequency)		
<ul style="list-style-type: none"> <li>Common-mode interference (<math>U_{SS}</math>)</li> <li>Series-mode interference (peak interference value &lt; rated value of input range)</li> </ul>	min. 90 dB min. 70 dB	
Crosstalk between the inputs	min. -50 dB	
Operational limit (in the entire temperature range, with reference to the input range)		
<ul style="list-style-type: none"> <li>Resistance-type sensor</li> </ul>	$\pm 0.1 \%$	
<ul style="list-style-type: none"> <li>Pt100, Pt200, Pt500, Pt1000 Standard</li> </ul>	$\pm 1.0 \text{ K}$	
<ul style="list-style-type: none"> <li>Pt100, Pt200, Pt500, Pt1000 Climatic</li> </ul>	$\pm 0.25 \text{ K}$	
<ul style="list-style-type: none"> <li>Ni100, Ni120, Ni200, Ni500, Ni 1000 Standard and Climatic</li> </ul>	$\pm 0.4 \text{ K}$	
<ul style="list-style-type: none"> <li>Cu10</li> </ul>	$\pm 1.5 \text{ K}$	
Basic error limit for resistance-type sensors (operational limit at 25 °C with reference to input range)		
<ul style="list-style-type: none"> <li>Resistance-type sensor</li> </ul>	$\pm 0.05 \%$	
<ul style="list-style-type: none"> <li>Pt100, Pt200, Pt500, Pt1000 Standard</li> </ul>	$\pm 0.6 \text{ K}$	
<ul style="list-style-type: none"> <li>Pt100, Pt200, Pt500, Pt1000 Climatic</li> </ul>	$\pm 0.13 \text{ K}$	
<ul style="list-style-type: none"> <li>Ni100, Ni120, Ni200, Ni500, Ni 1000 Standard and Climatic</li> </ul>	$\pm 0.2 \text{ K}$	
<ul style="list-style-type: none"> <li>Cu10</li> </ul>	$\pm 1.0 \text{ K}$	

Temperature error (with reference to the input range)	± 0.0009 %/K	
Linearity error (with reference to the input range)	± 0.01 %	
Repeatability (in steady state at 25° C with reference to input range)	± 0.05 %	
<b>Data for selecting a sensor</b>		
Input range (rated value)/input resistance		
<ul style="list-style-type: none"> <li>• Resistance-type sensor</li> </ul>	150 Ω/min. 10 MΩ 300 Ω/min. 10 MΩ 600 Ω/min. 10 MΩ 3000 Ω/min. 10 MΩ PTC min 10 MΩ	
<ul style="list-style-type: none"> <li>• Resistance thermometer</li> </ul>	Pt100/min. 10 MΩ Ni100/min. 10 MΩ Ni120/min. 10 MΩ Pt200/min. 10 MΩ Ni200/min. 10 MΩ Pt500/min. 10 MΩ Ni500/min. 10 MΩ Pt1000/min. 10 MΩ Ni1000/min. 10 MΩ Cu10/min. 10 MΩ	
Permitted input voltage (destruction limit)	max. 9 V	
Connection of the sensors		
<ul style="list-style-type: none"> <li>• For measuring resistance                             <ul style="list-style-type: none"> <li>– Two-wire connection</li> <li>– Three-wire connection</li> <li>– Four-wire connection</li> </ul> </li> </ul>	Yes, Yes, internal compensation of line resistances Yes	
Characteristic curve linearization	Yes, can be assigned parameters for Ptxxx, Nixxx	
Smoothing of the measured values	Yes, can be assigned parameters in 4 steps by means of digital filtering	
	<b>Step</b> None Weak Medium Strong	<b>Time constant</b> 1 x cycle time 4 x cycle time 32 x cycle time 64 x cycle time
¹In accordance with VDE 0660 Part 302/303, Type A		

### Use of Cu10 sensors

- Select "Three-wire thermal resistor" and "Cu10" at parameter assignment.
- Wire the Cu10 sensor in accordance with the three-wire connection method.
- Automatic, internal compensation of line resistance for the missing measuring line occurs during operation.

**Note**

Please note the following to ensure optimum line compensation in the case of Cu10:

- The sum of the cable resistance and measurement resistance must not exceed 31  $\Omega$ .
- The cable must have a resistance of no more than 8  $\Omega$  if you want to use the temperature range up to and above 312 °C.

Example: A 200 m Cu cable with a 0.5 mm<sup>2</sup> conductor cross-section has approximately 7  $\Omega$ . A smaller cross-section shortens the permissible cable length accordingly.

**Using PTC resistors**

PTCs are suitable for temperature monitoring and as thermal protective devices for complex drives and transformer windings.

- Select "Two-wire resistor" and "PTC" at parameter assignment:
- Connect the PTC in accordance with the two-wire connection method.
- Apply PTC resistors of type A (PTC thermistors) in accordance with DIN / VDE 0660, Part 302.
- Sensor data for the PTC resistor:

Features	Technical Specifications	Remarks
Switching points	<b>Behavior with rising temperature</b>	
	< 550 $\Omega$	<b>Normal range:</b> <ul style="list-style-type: none"> <li>• SIMATIC S7: Bit 0 = "0", Bit 2 = "0" (in the PII)</li> <li>• SIMATIC S5: Bit 3 = "0", Bit 5 = "0" (in the PII)</li> </ul>
	550 $\Omega$ to 1650 $\Omega$	<b>Prewarning range:</b> <ul style="list-style-type: none"> <li>• SIMATIC S7: Bit 0 = "0", Bit 2 = "1" (in the PII)</li> <li>• SIMATIC S5: Bit 3 = "0", Bit 5 = "1" (in the PII)</li> </ul>
	> 1650 $\Omega$	<b>Addressable range:</b> <ul style="list-style-type: none"> <li>• SIMATIC S7: Bit 0 = "1", Bit 2 = "0" (in the PII)</li> <li>• SIMATIC S5: Bit 3 = "1", Bit 5 = "0" (in the PII)</li> </ul>
	<b>Behavior with falling temperature</b>	
	> 750 $\Omega$	<b>Addressable range:</b> <ul style="list-style-type: none"> <li>• SIMATIC S7: Bit 0 = "1", Bit 2 = "0" (in the PII)</li> <li>• SIMATIC S5: Bit 3 = "1", Bit 5 = "0" (in the PII)</li> </ul>
	750 $\Omega$ to 540 $\Omega$	<b>Prewarning range:</b> <ul style="list-style-type: none"> <li>• SIMATIC S7: Bit 0 = "0", Bit 2 = "1" (in the PII)</li> <li>• SIMATIC S5: Bit 3 = "0", Bit 5 = "1" (in the PII)</li> </ul>
< 540 $\Omega$	<b>Normal range:</b> <ul style="list-style-type: none"> <li>• SIMATIC S7: Bit 0 = "0", Bit 2 = "0" (in the PII)</li> <li>• SIMATIC S5: Bit 3 = "0", Bit 5 = "0" (in the PII)</li> </ul>	
(TNF-5) °C (TNF+5) °C (TNF+15) °C Measuring voltage Voltage on the PTC	max. 550 $\Omega$ min. 1330 $\Omega$ min. 4000 $\Omega$ max. 7.5V	TNF= rated operating temperature

- Assignment in the process input image (PII) in the case of SIMATIC S7

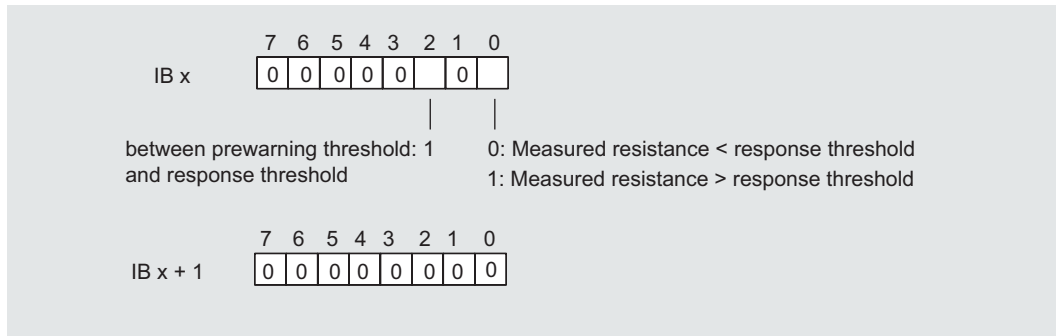

- Assignment in the process input image (PII) in the case of SIMATIC S5

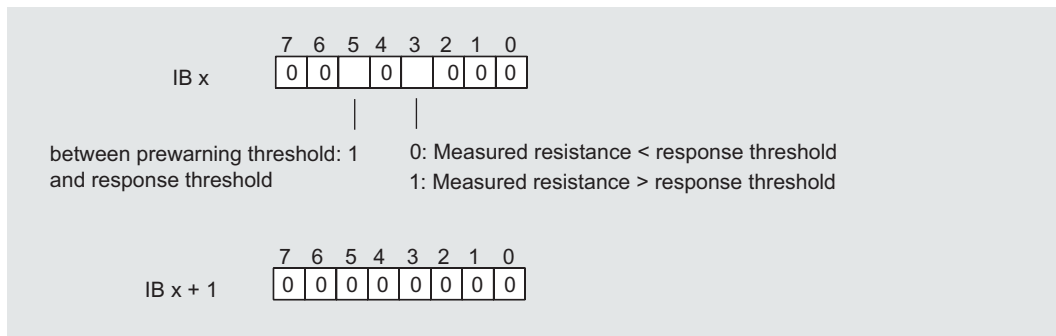

- Notes on programming

**Notice**

Only the bits 0+2 or 3+5 are relevant for the purposes of evaluation in the process input image. You can use bits 0+2 or 3+5 to monitor the temperature of a motor, for example.

Bits 0+2 or 3+5 in the process input image does not have a retentive function. Make sure at parameter assignment that motor start-up is controlled (by means of an acknowledgment), for example.

Bits 0+2 or 3+5 cannot be set at the same time, but set one after the other.

For safety reasons, always evaluate the diagnostic inputs of the 2AI RTD High Feature because measurement is not possible when the EM is removed, when the power supply to the EM has failed, or in the event of a wire break or short-circuit of the measuring lines.

**Example**

The diagram below shows the temperature pattern and the switching points belonging to it.

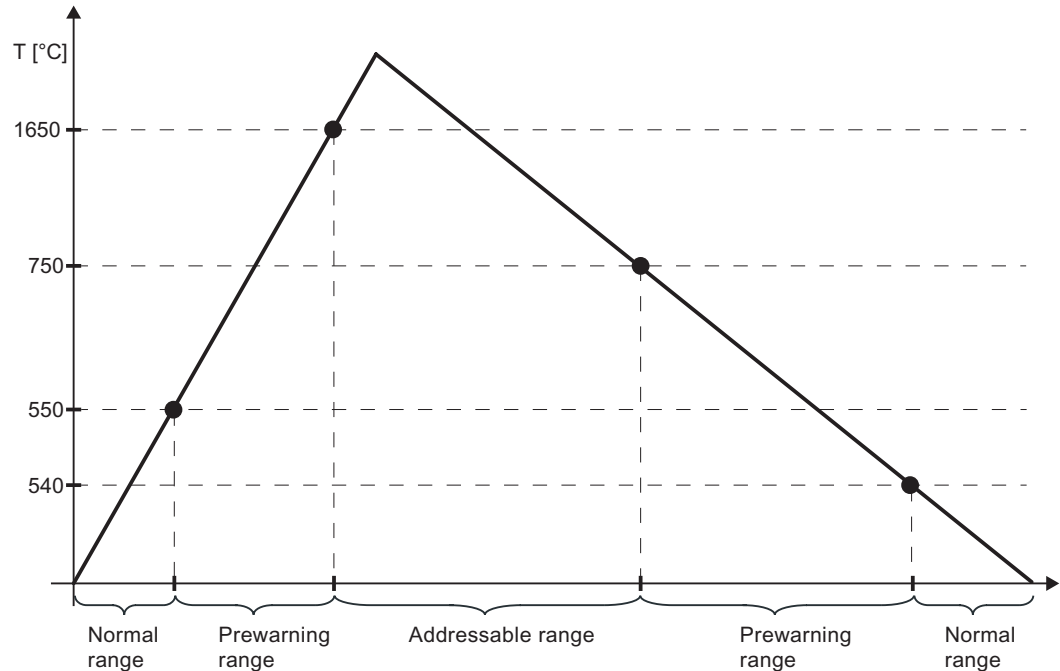

## 4.17 2AI TC Standard analog electronic module (6ES7134-4JB00-0AB0)

**Properties**

- 2 inputs for thermocouple or voltage measurement
- Input ranges:
  - Voltage measurement:  $\pm 80$  mV, resolution 15 bits + sign
  - Thermocouples: Type E, N, J, K, L, S, R, B, T, resolution 15 bits + sign
- Isolated from the load voltage  $L+$
- Linearization of the sensor characteristic curves
- Permissible common mode voltage  $2 V_{ACSS}$

**General terminal assignment**

**Note**

Terminals 4, 8, A4, A8, A3 and A7 are only available at specified terminal modules.

Terminal assignment for 2AI TC Standard (6ES7134-4JB00-0AB0)				
Terminal	Assignment	Terminal	Assignment	Notes
1	M <sub>0+</sub>	5	M <sub>1+</sub>	<ul style="list-style-type: none"> <li>M<sub>n+</sub>: Measuring line positive, channel n</li> <li>M<sub>n-</sub>: Measuring line negative, channel n</li> <li>M<sub>ana</sub>: Ground of the module</li> <li>n.c.: Not connected (max. DC 30 V can be connected)</li> <li>AUX1: Protective-conductor terminal or potential bus (freely usable up to 230 VAC)</li> </ul>
2	M <sub>0-</sub>	6	M <sub>1-</sub>	
3	M <sub>ana</sub>	7	M <sub>ana</sub>	
4	n.c.	8	n.c.	
A4	AUX1	A8	AUX1	
A3	AUX1	A7	AUX1	

**Usable terminal modules**

Usable terminal modules for 2AI TC Standard (6ES7134-4JB00-0AB0)				
TM-E15C26-A1 (6ES7193-4CA50-0AA0)	TM-E15C24-A1 (6ES7193-4CA30-0AA0)	TM-E15C24-01 (6ES7193-4CB30-0AA0)	TM-E15C23-01 (6ES7193-4CB10-0AA0)	← Spring terminal
TM-E15S26-A1 (6ES7193-4CA40-0AA0)	TM-E15S24-A1 (6ES7193-4CA20-0AA0)	TM-E15S24-01 (6ES7193-4CB20-0AA0)	TM-E15S23-01 (6ES7193-4CB00-0AA0)	← Screw terminal
TM-E15N26-A1 (6ES7193-4CA80-0AA0)	TM-E15N24-A1 (6ES7193-4CA70-0AA0)	TM-E15N24-01 (6ES7193-4CB70-0AA0)	TM-E15N23-01 (6ES7193-4CB60-0AA0)	← Fast Connect
				<p>Wiring examples</p> <p>Voltage measurement as for 2AI U Standard</p>



Block diagram

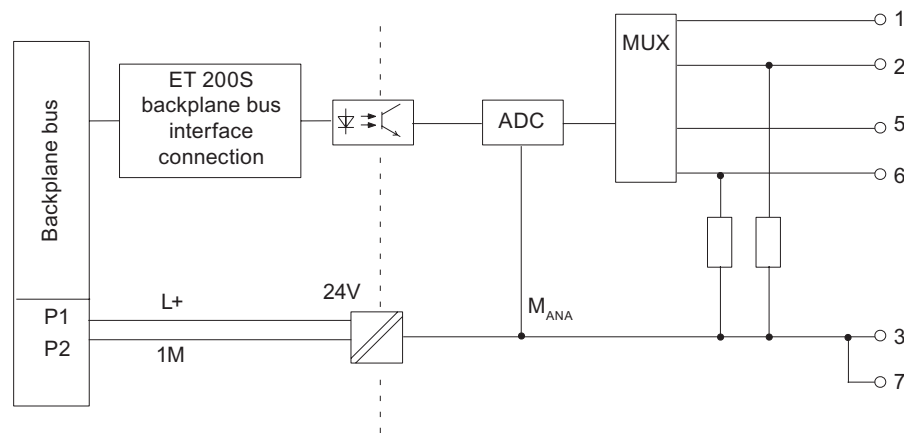

Figure 4-17 Block diagram of the 2AI TC Standard

2AI TC Standard Technical Specifications (6ES7134-4JB00-0AB0)

Dimensions and Weight	
Dimensions W × H × D (mm) (the total dimensions depend on the selected terminal module)	15 x 81 x 52
Weight	Approx. 40 g
Data for specific modules	
Supports isochronous operation	no
Number of inputs	2
Cable length	
• Shielded	max. 50 m
Parameter length	4 bytes
Voltages, currents, potentials	
Rated load voltage L+ (from the power module)	24 VDC
• Reverse polarity protection	Yes
Galvanic isolation	
• Between the channels and backplane bus	Yes
• Between the channels and load voltage L+	Yes
• Between the channels	no
• Between the channels and 24 V supply voltage	Yes
Permissible potential difference	
• Between M <sub>ANA</sub> and the central grounding point (U <sub>iso</sub> )	75 VDC / 60 VAC
• Between the inputs and M <sub>ANA</sub> (U <sub>CM</sub> )	2 VAC <sub>SS</sub>

Insulation tested	500 VDC	
Current consumption		
• From load voltage L+	max. 30 mA	
Power dissipation of the module	Typically 0.6 W	
<b>Status, interrupts, diagnostics</b>		
Diagnostics function		
• Group error	Red "SF" LED	
• Diagnostic functions readable	Yes	
<b>Analog value generation</b>		
Measuring principle	Integrative	
Integration time/conversion time/resolution per channel:		
• Integration time can be assigned parameters	Yes	
• Interference frequency suppression in Hz	60	50
• Integration time in milliseconds	16.7	20
• Basic conversion time incl. integration time in ms	55	65
• Additional conversion time for wire break check diagnosis in ms	20	20
• Cycle time in ms	Number of active channels per module x conversion time	
• Resolution (including overrange)	15 bits plus sign	
<b>Suppression of interference, limits of error</b>		
Interference voltage suppression for $f = n \times (f_1 \pm 1 \%)$ , ( $f_1 =$ interference frequency)		
• Common-mode interference ( $U_{ss}$ )	min. 90 dB	
• Common mode interference (peak value of interference < rated value of input range)	min. 70 dB	
Crosstalk between the inputs	min. -50 dB	
Operational limit (over the entire temperature range, with reference to the input range) <sup>1</sup>	$\pm 0.6 \%$	
Basic error limit (operational limit at 25 °C with reference to input range) <sup>1</sup>	$\pm 0.4 \%$	
Temperature error (with reference to the input range)	$\pm 0.005 \%/K$	
Linearity error (with reference to the input range)	$\pm 0.01 \%$	
Repeatability (in steady state at 25° C with reference to input range)	$\pm 0.05 \%$	

Data for selecting a sensor											
Input range (rated value)/input resistance											
• Voltage	$\pm 80$ mV/min. $1\text{ M}\Omega$										
• Thermocouple	Type E, N, J, K, L, S, R, B, T/min. $1\text{ M}\Omega$										
Permitted input voltage (destruction limit)	$\pm 10$ V, continuous										
Connection of the sensors											
• For measuring voltage	supported										
Characteristic curve linearization	Yes, can be assigned parameters for type E, N, J, K, L, S, R, B, T as per IEC 584										
Temperature compensation											
• Internal temperature compensation	not supported										
• External temperature compensation by looping a compensating box into the measuring circuit	Possible, one external compensating box per channel										
• External compensation by means of temperature value obtained at an analog module of the same ET 200S station	Yes										
Smoothing of the measured values	Yes, can be assigned parameters in 4 steps by means of digital filtering										
	<table border="1"> <thead> <tr> <th>Step</th> <th>Time constant</th> </tr> </thead> <tbody> <tr> <td>None</td> <td>1 x cycle time</td> </tr> <tr> <td>Weak</td> <td>4 x cycle time</td> </tr> <tr> <td>Medium</td> <td>32 x cycle time</td> </tr> <tr> <td>Strong</td> <td>64 x cycle time</td> </tr> </tbody> </table>	Step	Time constant	None	1 x cycle time	Weak	4 x cycle time	Medium	32 x cycle time	Strong	64 x cycle time
Step	Time constant										
None	1 x cycle time										
Weak	4 x cycle time										
Medium	32 x cycle time										
Strong	64 x cycle time										
<sup>1</sup> for Type N: from $-150\text{ }^{\circ}\text{C}$ , type B: from $200\text{ }^{\circ}\text{C}$ , type T: from $-230\text{ }^{\circ}\text{C}$											

### Compensation of thermocouples with a compensating box

As well as the error limits of the 2AI TC Standard electronic module (see Table "Technical specifications 2AI TC Standard (6ES7134-4JB00-0AB0)" in this chapter) you must also take the accuracy of the compensating box into account.

**Compensation of thermocouples with a Pt100 on the 2AI RTD Standard**

<b>Factors affecting the accuracy of the temperature measurement</b>	
Wiring rules	<p>Ensure there is good thermal contact between the reference junction and the Pt100 used for compensation.</p> <p>We recommend that you wire the Pt100 with a four-wire connection.</p>
Additional technical specifications on the error limits of the 2AI TC	<p>The accuracy of the thermal resistor (Pt100) used for compensation must be taken into account.<sup>1</sup></p> <p>The error of the measurement input (2AI RTD Standard) used for compensation must be taken into account.<sup>1</sup></p>
<p><sup>1</sup> In the case of thermocouples with a characteristic curve with a very shallow gradient, these errors can lead to a major measurement discrepancy.                      For the following thermocouples, this causes a limitation of the input range of the thermocouples in which the accuracy information in the manual applies:</p> <ul style="list-style-type: none"> <li>• Type N: -100 °C</li> <li>• Type K: -230 °C</li> <li>• Type E: -230 °C</li> </ul>	

**See also**

2AI U Standard analog electronic module (6ES7134-4FB01-0AB0) (Page 4-37)

**4.18 2AI RTD High Feature analog electronic module (6ES7134-4NB01-0AB0)**

**Properties**

- 2 inputs for thermocouple or voltage measurement
- Input ranges:
  - Voltage measurement: ± 80 mV, resolution 15 bits + sign
  - Thermocouples: Types E, N, J, K, L, S, R, B, T, C, resolution 15 bits + sign
- Isolated from the load voltage L+
- Linearization of the sensor characteristic curves
- Permitted common-mode voltage 140 VDC/100 VAC
- Internal reference junction in connection with TM-E15S24-AT or TM-E15C24-AT

General terminal assignment

Terminal assignment for 2AI TC High Feature (6ES7134-4NB01-0AB0)				
Terminal	Assignment	Terminal	Assignment	Notes
1	M <sub>0+</sub>	5	M <sub>1+</sub>	<ul style="list-style-type: none"> <li>M<sub>n+</sub>: Measuring line positive, channel n</li> <li>M<sub>n-</sub>: Measuring line negative, channel n</li> </ul>
2	M <sub>0-</sub>	6	M <sub>1-</sub>	

Usable terminal modules

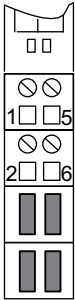
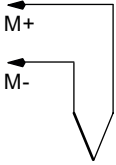
Usable terminal modules for 2AI TC High Feature (6ES7134-4NB01-0AB0)	
TM-E15C24-AT (6ES7193-4CL30-0AA0)	← Spring terminal
TM-E15S24-AT (6ES7193-4CL20-0AA0)	← Screw terminal
	<p>Sample connection</p> 

Block diagram

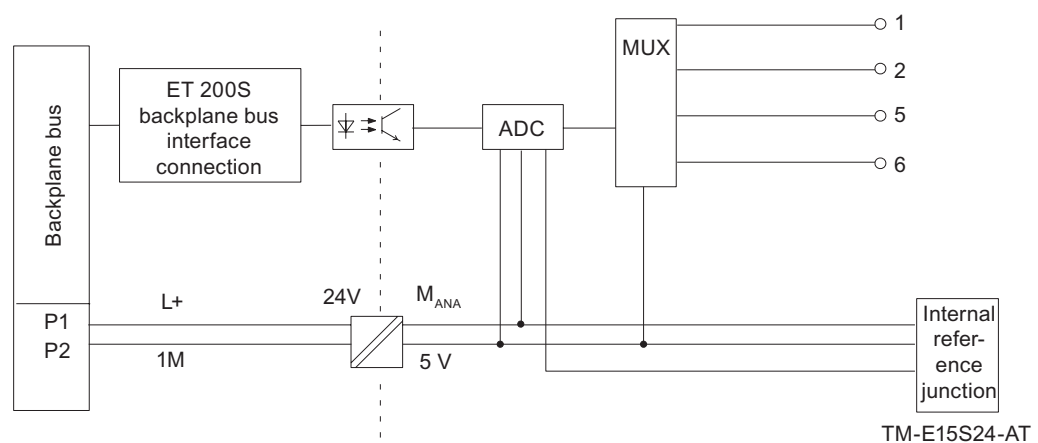

Figure 4-18 Block diagram of the 2AI TC High Feature

**2AI TC High Feature Technical Specifications (6ES7134-4NB01-0AB0)**

<b>Dimensions and Weight</b>	
Dimensions W × H × D (mm) (the total dimensions depend on the selected terminal module)	15 x 81 x 52
Weight	Approx. 40 g
<b>Data for specific modules</b>	
Supports isochronous operation	no
Number of inputs	2
Cable length	
• Shielded	max. 50 m
Parameter length	4 bytes
<b>Voltages, currents, potentials</b>	
Rated load voltage L+ (from the power module)	24 VDC
• Reverse polarity protection	Yes
Galvanic isolation	
• Between the channels and backplane bus	Yes
• Between the channels and load voltage L+	Yes
• Between the channels	no
• Between the channels and 24 V supply voltage	Yes
Permissible potential difference	
• Between M <sub>ANA</sub> and the central grounding point (U <sub>iso</sub> )	75 VDC / 60 VAC
• Between the inputs and M <sub>ANA</sub> (U <sub>CM</sub> )	140 VDC / 100 VAC
Insulation tested	500 VDC
Current consumption	
• From load voltage L+	max. 30 mA
Power dissipation of the module	Typically 0.6 W
<b>Status, interrupts, diagnostics</b>	
Diagnostics function	
• Group error	Red "SF" LED
• Diagnostic functions readable	Yes

Analog value generation		
Measuring principle	Integrative	
Integration time/conversion time/resolution per channel:		
<ul style="list-style-type: none"> <li>Integration time can be assigned parameters</li> </ul>	Yes	
<ul style="list-style-type: none"> <li>Interference frequency suppression in Hz</li> </ul>	60	50
<ul style="list-style-type: none"> <li>Integration time in milliseconds</li> </ul>	16.7	20
<ul style="list-style-type: none"> <li>Basic conversion time incl. integration time in ms</li> </ul>	66	80
<ul style="list-style-type: none"> <li>Additional conversion time for wire break check diagnosis in ms</li> </ul>	5	5
<ul style="list-style-type: none"> <li>Cycle time in ms</li> </ul>	Number of active channels per module x conversion time	
<ul style="list-style-type: none"> <li>Resolution (including overrange)</li> </ul>	15 bits plus sign	
Suppression of interference, limits of error		
Interference voltage suppression for $f = n \times (f1 \pm 1 \%)$ , ( $f1 =$ interference frequency)		
<ul style="list-style-type: none"> <li>Common-mode interference (<math>U_{SS}</math>)</li> <li>Series-mode interference (peak interference value &lt; rated value of input range)</li> </ul>	min. 90 dB min. 70 dB	
Crosstalk between the inputs	min. -50 dB	
Operational limit for $\pm 80$ mV (over the entire temperature range with reference to the input range)	$\pm 0.1 \%$	
Operational limit for thermocouples (over the entire temperature range with reference to the input range) <sup>1</sup>	$\pm 1.5$ K	
Operational limit for thermocouple type C (in the entire temperature range with reference to the input range) <sup>1</sup>	$\pm 7$ K	
Basic error limit for $\pm 80$ mV (operational limit at 25 °C with reference to the input range)	$\pm 0.05 \%$	
Basic error limit for thermocouples (operational limit at 25 °C with reference to input range) <sup>1</sup>	$\pm 1$ K	
Basic error limit for thermocouples of type C (operational limit at 25 °C with reference to the input range) <sup>1</sup>	$\pm 5$ K	
Temperature error (with reference to the input range)	$\pm 0.005 \%/K$	
Linearity error (with reference to the input range)	$\pm 0.01 \%$	

Repeatability (in steady state at 25 °C with reference to input range)	± 0.05 %	
Overall error limits using internal compensation		
<ul style="list-style-type: none"> <li>Operational limit (in the entire temperature range with a static, thermal state, ambient temperature change &lt; 0.3 K/min)<sup>2</sup></li> </ul>	± 2.5 K	
<ul style="list-style-type: none"> <li>Basic error limit (operational limit at 25 °C with a static, thermal state, ambient temperature change &lt; 0.3 K/min)<sup>3</sup></li> </ul>	± 1.5 K	
<b>Data for selecting a sensor</b>		
Input range (rated value)/input resistance		
<ul style="list-style-type: none"> <li>Voltage</li> </ul>	± 80m V/min. 1 MΩ	
<ul style="list-style-type: none"> <li>Thermocouple</li> </ul>	Type E, N, J, K, L, S, R, B, T, C/min. 1 MΩ	
Permitted input voltage (destruction limit)	± 20 V, continuous	
Connection of the sensors		
<ul style="list-style-type: none"> <li>For measuring voltage</li> </ul>	supported	
Characteristic curve linearization	Yes, can be assigned parameters for type E, N, J, K, L, S, R, B, T, C as per IEC 584	
Temperature compensation		
<ul style="list-style-type: none"> <li>Internal temperature compensation</li> </ul>	Possible with TM-E15S24-ATTM-E15C24-AT	
<ul style="list-style-type: none"> <li>External temperature compensation by looping a compensating box into the measuring circuit</li> </ul>	Possible, one external compensating box per channel	
Smoothing of the measured values	Yes, can be assigned parameters in 4 steps by means of digital filtering	
	<b>Step</b> None Weak Medium Strong	<b>Time constant</b> 1 x cycle time 4 x cycle time 32 x cycle time 64 x cycle time
<sup>1</sup> The specified error limits apply starting with the following temperatures: <ul style="list-style-type: none"> <li>Thermocouple Type T: -200 °C</li> <li>Thermocouple type K: -100 °C</li> <li>Thermocouple Type B: +700 °C</li> <li>Thermocouple type N: -150 °C</li> <li>Thermocouple type E: -150 °C</li> <li>Thermocouple Type R: +200 °C</li> <li>Thermocouple Type S: +100 °C</li> </ul> <sup>2</sup> In the case of thermocouple type C: ± 8 K <sup>3</sup> In the case of thermocouple type C: ± 6 K		



### Compensation of thermocouples with a compensating box

As well as the error limits of the 2AI TC High Feature electronic module (see Table "Technical specifications 2AI TC High Feature (6ES7134-4NB01-0AB0)" in this chapter) you must also take the accuracy of the compensating box into account.

### Internal compensation with TM-E 15S24-AT or TM-E15C24-AT

Factors affecting the accuracy of the temperature measurement	
Rules on using internal temperature compensation	The connected channel with internal compensation must be assigned parameters separately.
	Don't insert the 2AI TC High Feature directly next to a power module with high incoming current (> 3 A). An incoming current of 10 A can result in a further $\pm 2$ K error.
Additional technical specifications for the error limits of the 2AI TC High Feature	The station must be in a static state <sup>1</sup> to ensure that the specified accuracy is achieved.
	Accuracy is achieved 30 minutes after the static state has been achieved.
	The overall malfunction of the channel is caused by the combination of the input error and the internal compensation error.
<sup>1</sup> The static state is defined by an almost constant ambient temperature (no draft, for example, in a closed cabinet!)	

### See also

2AI U Standard analog electronic module (6ES7134-4FB01-0AB0) (Page 4-37)

## 4.19 2AO U Standard analog electronic module (6ES7135-4FB01-0AB0)

### Properties

- 2 outputs for voltage output
- Output range:
  - $\pm 10$  V, resolution 13 bits + sign
  - 1 to 5 V, resolution 12 bits
- Isolated from the load voltage L+

**General terminal assignment**

**Note**

Terminals 4, 8, A4, A8, A3 and A7 are only available at specified terminal modules.

Terminal assignment for 2AO U Standard (6ES7135-4FB01-0AB0)				
Terminal	Assignment	Terminal	Assignment	Notes
1	QV <sub>0</sub>	5	QV <sub>1</sub>	<ul style="list-style-type: none"> <li>QV<sub>n</sub>: Analog output voltage, channel n</li> <li>S<sub>n+</sub>: Tracer line positive, channel n</li> <li>S<sub>n-</sub>: Tracer line negative, channel n</li> <li>M<sub>ana</sub>: Ground of the module</li> <li>AUX1: Protective-conductor terminal or potential bus (freely usable up to 230 VAC)</li> </ul>
2	S <sub>0+</sub>	6	S <sub>1+</sub>	
3	M <sub>ana</sub>	7	M <sub>ana</sub>	
4	S <sub>0-</sub>	8	S <sub>1-</sub>	
A4	AUX1	A8	AUX1	
A3	AUX1	A7	AUX1	

**Usable terminal modules**

Usable terminal modules for 2AO U Standard (6ES7135-4FB01-0AB0)		
TM-E15C26-A1 (6ES7193-4CA50-0AA0)	TM-E15C24-01 (6ES7193-4CB30-0AA0)	← Spring terminal
TM-E15S26-A1 (6ES7193-4CA40-0AA0)	TM-E15S24-01 (6ES7193-4CB20-0AA0)	← Screw terminal
TM-E15N26-A1 (6ES7193-4CA80-0AA0)	TM-E15N24-01 (6ES7193-4CB70-0AA0)	← Fast Connect
<div style="display: flex; justify-content: space-around;"> <div style="text-align: center;"> </div> <div style="text-align: center;"> <p>Wiring examples</p> <div style="display: flex; justify-content: space-around;"> <div style="text-align: center;"> <p>2-wire</p> </div> <div style="text-align: center;"> <p>4-wire</p> </div> </div> </div> </div>		

Block diagram

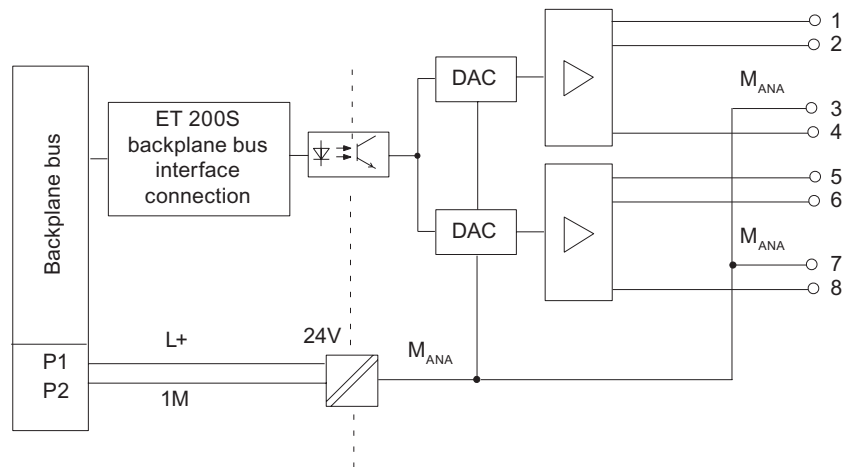

Figure 4-19 Block diagram of the 2AO U Standard

2AO U Standard Technical Specifications (6ES7135-4FB01-0AB0)

Dimensions and Weight	
Dimensions W × H × D (mm) (the total dimensions depend on the selected terminal module)	15 x 81 x 52
Weight	Approx. 40 g
Data for specific modules	
Supports isochronous operation	no
Number of outputs	2
Cable length	
• Shielded	max. 200 m
Parameter length	7 bytes
Voltages, currents, potentials	
Rated load voltage L+ (from the power module)	24 VDC
• Reverse polarity protection	Yes
Galvanic isolation	
• Between the channels and backplane bus	Yes
• Between the channels and load voltage L+	Yes
• Between the channels	no
Permissible potential difference	
• Between MANA and the central grounding point ( $U_{iso}$ )	75 VDC / 60 VAC
Insulation tested	500 VDC
Current consumption	
• From load voltage L+	max. 130 mA
Power dissipation of the module	max. 2 W

<b>Status, interrupts, diagnostics</b>	
Diagnostics function	
• Group error	Red "SF" LED
• Diagnostic functions readable	Yes
<b>Analog value generation</b>	
Resolution (including overrange)	± 10 V/13 bits + sign 1 to 5 V/12 bits
Cycle time	max. 1.5 ms
Settling time	
• For resistive load	0.1 ms
• For capacitive load	0.5 ms
• For inductive load	0.5 ms
Substitute value can be assigned parameters	Yes
<b>Suppression of interference, limits of error</b>	
Crosstalk between the outputs	min. -40 dB
Operational limit (in the entire temperature range, with reference to the output range)	± 0.4 %
Basic error limit (operational limit at 25 °C with reference to output range)	± 0.2 %
Temperature error (with reference to the output range)	± 0.01 %/K
Linearity error (with reference to the output range)	± 0.02 %
Repeatability (in steady state at 25 °C with reference to output range)	± 0.05 %
Output ripple (with reference to output range, bandwidth 0 to 50 kHz)	± 0.02 %
<b>Data for selecting an actuator</b>	
Output range (rated value)	± 10 V 1 V to 5 V
Load resistance	min. 1.0 kΩ
• For capacitive load	max. 1 μF
• Short-circuit protection	Yes
• Short-circuit voltage	Approx. 25 mA
Destruction limit against voltages/currents applied from outside	
• Voltage at the outputs to M <sub>ANA</sub>	15 V continuous; 75 V for max. 1 ms (sampling ratio 1:20)
• Current	max. 50 mA DC
Connection of actuators	
• Two-wire connection	Possible, without compensation of cable resistance
• Four-wire connection	Yes

## 4.20 2AO U High Feature analog electronic module (6ES7135-4LB02-0AB0)

### Properties

- 2 outputs for voltage output
- Output range:
  - $\pm 10$  V, resolution 15 bits + sign
  - 1 to 5 V, resolution 14 bits
- Isolated from the load voltage L+
- Supports isochronous operation
  - Minimum time for the synchronous DP cycle ( $T_{DPmin}$ ): 3.75 ms
  - Minimum conversion time of the output modules: ( $T_{WAmin}$ ): 1.5 ms

### General terminal assignment

---

#### Note

Terminals 4, 8, A4, A8, A3 and A7 are only available at specified terminal modules.

---

Terminal assignment for 2AO U High Feature (6ES7135-4LB02-0AB0)

Terminal	Assignment	Terminal	Assignment	Notes
1	QV <sub>0</sub>	5	QV <sub>1</sub>	<ul style="list-style-type: none"> <li>• QV<sub>n</sub>: Analog output voltage, channel n</li> <li>• S<sub>n+</sub>: Tracer line positive, channel n</li> <li>• S<sub>n-</sub>: Tracer line negative, channel n</li> <li>• M<sub>ana</sub>: Ground of the module</li> <li>• AUX1: Protective-conductor terminal or potential bus (freely usable up to 230 VAC)</li> </ul>
2	S <sub>0+</sub>	6	S <sub>1+</sub>	
3	M <sub>ana</sub>	7	M <sub>ana</sub>	
4	S <sub>0-</sub>	8	S <sub>1-</sub>	
A4	AUX1	A8	AUX1	
A3	AUX1	A7	AUX1	

Usable terminal modules

Usable terminal modules for 2AO U High Feature (6ES7135-4LB02-0AB0)		
TM-E15C26-A1 (6ES7193-4CA50-0AA0)	TM-E15C24-01 (6ES7193-4CB30-0AA0)	← Spring terminal
TM-E15S26-A1 (6ES7193-4CA40-0AA0)	TM-E15S24-01 (6ES7193-4CB20-0AA0)	← Screw terminal
TM-E15N26-A1 (6ES7193-4CA80-0AA0)	TM-E15N24-01 (6ES7193-4CB70-0AA0)	← Fast Connect
<p style="text-align: center;">Wiring examples</p> <div style="display: flex; justify-content: space-around;"> <div style="text-align: center;"> <p>2-wire</p> </div> <div style="text-align: center;"> <p>4-wire</p> </div> </div>		

Block diagram

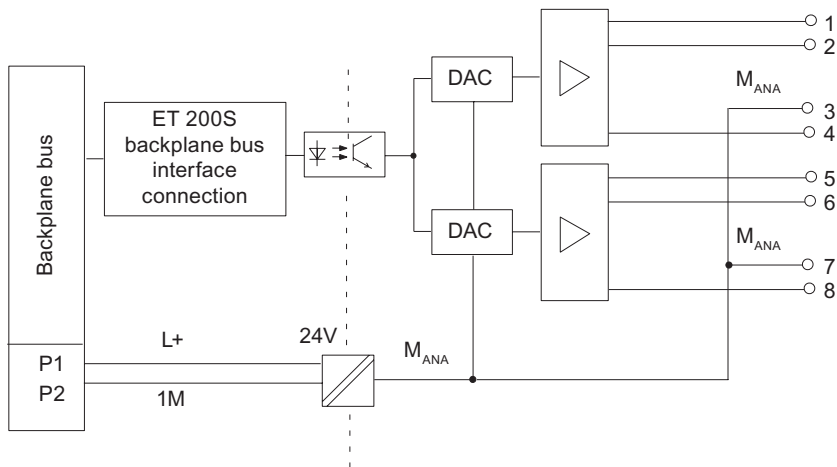

Figure 4-20 Block diagram of the 2AO U High Feature

## 2AO U High Feature Technical Specifications (6ES7135-4LB02-0AB0)

<b>Dimensions and Weight</b>	
Dimensions W × H × D (mm) (the total dimensions depend on the selected terminal module)	15 x 81 x 52
Weight	Approx. 40 g
<b>Data for specific modules</b>	
Supports isochronous operation	Yes
Number of outputs	2
Cable length	
• Shielded	max. 200 m
Parameter length	7 bytes
<b>Voltages, currents, potentials</b>	
Rated load voltage L+ (from the power module)	24 VDC
• Reverse polarity protection	Yes
Galvanic isolation	
• Between the channels and backplane bus	Yes
• Between the channels and load voltage L+	Yes
• Between the channels	no
Permissible potential difference	
• Between MANA and the central grounding point ( $U_{iso}$ )	75 VDC / 60 VAC
Insulation tested	500 VDC
Current consumption	
• From load voltage L+	max. 130 mA
Power dissipation of the module	max. 2 W
<b>Status, interrupts, diagnostics</b>	
Diagnostics function	
• Group error display	Red "SF" LED
• Diagnostic information readable	supported
Substitute values can be applied	Yes, parameterizable
<b>Analog value generation</b>	
Resolution (including sign)	± 10 V/16 bits 1 V to 5 V/14 bits
Conversion time (per channel)	max. 1.0 ms
Settling time	
• For resistive load	0.1 ms
• For capacitive load	0.5 ms
• For inductive load	0.5 ms

<b>Suppression of interference, limits of error</b>	
Crosstalk between the outputs	> 60 dB
Operational limit (in the entire temperature range, with reference to the output range)	± 0.07 %
Basic error limit (operational limit at 25 °C with reference to output range)	± 0.03 %
Temperature error (with reference to the output range)	± 0.001 %/K
Linearity error (with reference to the output range)	± 0.02 %
Repeatability (in steady state at 25 °C with reference to output range)	± 0.01 %
Output ripple; range 0 Hz to 50 kHz (relative to output range)	± 0.02 %
<b>Data for selecting an actuator</b>	
Output range (rated value)	± 10 V 1 V to 5 V
Load impedance (in the rated range of the output) • At voltage outputs • Capacitive load	min. 1.0 kΩ max. 1 μF
Voltage output • Short-circuit protection • Short-circuit voltage	yes approx. 25 mA
Destruction limit against voltages/currents applied from outside • Voltage at the outputs to M <sub>ANA</sub> • Current	max. 15 V continuous; 75 V for max. 1 ms (sampling ratio 1:20) max. 50 mA DC
Connection of actuators • Voltage output 2-wire connection 4-wire connection	Possible, without compensation of the line resistances Possible



## 4.21 2AO I Standard analog electronic module (6ES7135-4GB01-0AB0)

### Properties

- 2 outputs for current output
- Output range:
  - $\pm 20$  mA, resolution 13 bits + sign
  - 4 to 20 mA, resolution 13 bits
- Isolated from the load voltage L+

### General terminal assignment

---

#### Note

Terminals 4, 8, A4, A8, A3 and A7 are only available at specified terminal modules.

---

Terminal assignment for 2AO I Standard (6ES7135-4GB01-0AB0)				
Terminal	Assignment	Terminal	Assignment	Notes
1	QI <sub>0</sub>	5	QI <sub>1</sub>	<ul style="list-style-type: none"> <li>• QI<sub>n</sub>: Current analog output, channel n</li> <li>• M<sub>ana</sub>: Ground of the module</li> <li>• n.c.: Not connected (max. DC 30 V can be connected)</li> <li>• AUX1: Protective-conductor terminal or potential bus (freely usable up to 230 VAC)</li> </ul>
2	n.c.	6	n.c.	
3	M <sub>ana</sub>	7	M <sub>ana</sub>	
4	n.c.	8	n.c.	
A4	AUX1	A8	AUX1	
A3	AUX1	A7	AUX1	

Usable terminal modules

Usable terminal modules for 2AO I Standard (6ES7135-4GB01-0AB0)				
TM-E15C26-A1 (6ES7193-4CA50-0AA0)	TM-E15C24-A1 (6ES7193-4CA30-0AA0)	TM-E15C24-01 (6ES7193-4CB30-0AA0)	TM-E15C23-01 (6ES7193-4CB10-0AA0)	← Spring terminal
TM-E15S26-A1 (6ES7193-4CA40-0AA0)	TM-E15S24-A1 (6ES7193-4CA20-0AA0)	TM-E15S24-01 (6ES7193-4CB20-0AA0)	TM-E15S23-01 (6ES7193-4CB00-0AA0)	← Screw terminal
TM-E15N26-A1 (6ES7193-4CA80-0AA0)	TM-E15N24-A1 (6ES7193-4CA70-0AA0)	TM-E15N24-01 (6ES7193-4CB70-0AA0)	TM-E15N23-01 (6ES7193-4CB60-0AA0)	← Fast Connect
				<p>Sample connection</p>

Block diagram

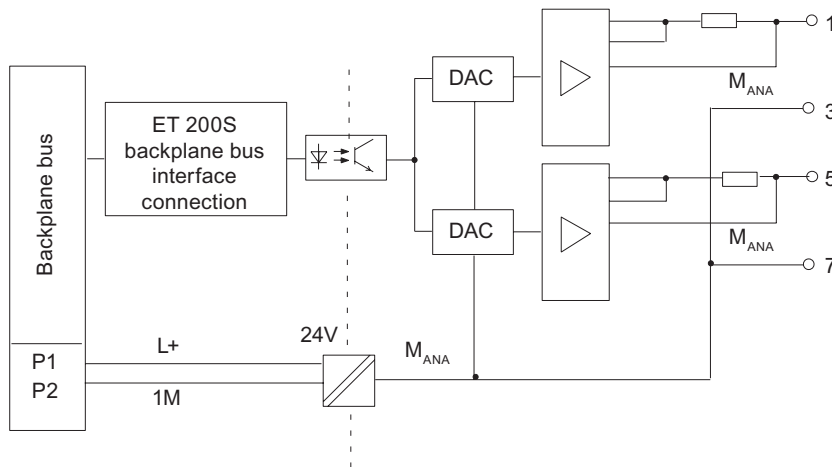

Figure 4-21 Block diagram of the 2AO I Standard

## 2AO I Standard Technical Specifications (6ES7135-4GB01-0AB0)

<b>Dimensions and Weight</b>	
Dimensions W × H × D (mm) (the total dimensions depend on the selected terminal module)	15 x 81 x 52
Weight	Approx. 40 g
<b>Data for specific modules</b>	
Supports isochronous operation	no
Number of outputs	2
Cable length	
• Shielded	max. 200 m
Parameter length	7 bytes
<b>Voltages, currents, potentials</b>	
Rated load voltage L+ (from the power module)	24 VDC
• Reverse polarity protection	Yes
Galvanic isolation	
• Between the channels and backplane bus	Yes
• Between the channels and load voltage	Yes
• Between the channels	no
Permissible potential difference	
• Between MANA and the central grounding point ( $U_{iso}$ )	75 VDC / 60 VAC
Insulation tested	500 VDC
Current consumption	
• From the power supply L+	max. 150 mA
Power dissipation of the module	max. 2 W
<b>Status, interrupts, diagnostics</b>	
Diagnostics function	
• Group error	Red "SF" LED
• Diagnostic functions readable	Yes
<b>Analog value generation</b>	
Resolution (including overrange)	± 20 mA/13 bits + sign 4 mA to 20 mA/13 bits
Cycle time	max. 1.5 ms
Settling time	
• For resistive load	0.1 ms
• For capacitive load	0.5 ms
• For inductive load	0.5 ms
Substitute values can be applied	Yes

<b>Suppression of interference, limits of error</b>	
Crosstalk between the outputs	min. -40 dB
Operational limit (in the entire temperature range, with reference to the output range)	± 0.5 %
Basic error limit (operational limit at 25 °C with reference to output range)	± 0.3 %
Temperature error (with reference to the output range)	± 0.01 %/K
Linearity error (with reference to the output range)	± 0.02 %
Repeatability (in steady state at 25 °C with reference to output range)	± 0.05 %
Output ripple (with reference to output range, bandwidth 0 to 50 kHz)	± 0.02 %
<b>Data for selecting an actuator</b>	
Output range (rated value)	± 20 mA 4 to 20 mA
Load resistance	max. 500 Ω
• For inductive load	1 mH
• Open circuit voltage	18 V
Destruction limit against voltages/currents applied from outside	
• Voltage at the outputs to M <sub>ANA</sub>	15 V continuous; 75 V for max. 1 ms (sampling ratio 1:20)
• Current	max. 50 mA DC
Connection of actuators	
• Two-wire connection	Yes
• Four-wire connection	no

## 4.22 2AO I High Feature analog electronic module (6ES7135-4MB02-0AB0)

### Properties

- 2 outputs for current output
- Output range:
  - ± 20 mA, resolution 15 bits + sign
  - 4 to 20 mA, resolution 15 bits
- Isolated from the load voltage L+
- Supports isochronous operation
  - Minimum time for the synchronous DP cycle ( $T_{DPmin}$ ): 3.75 ms
  - Minimum conversion time of the output modules: ( $T_{WAmin}$ ): 1.5 ms

**General terminal assignment**

**Note**

Terminals 4, 8, A4, A8, A3 and A7 are only available at specified terminal modules.

Terminal assignment for 2AO I High Feature (6ES7135-4MB02-0AB0)				
Terminal	Assignment	Terminal	Assignment	Notes
1	QI <sub>0</sub>	5	QI <sub>1</sub>	<ul style="list-style-type: none"> <li>QI<sub>n</sub>: Current analog output, channel n</li> <li>M<sub>ana</sub>: Ground of the module</li> <li>n.c.: Not connected (max. DC 30 V can be connected)</li> <li>AUX1: Protective-conductor terminal or potential bus (freely usable up to 230 VAC)</li> </ul>
2	n.c.	6	n.c.	
3	M <sub>ana</sub>	7	M <sub>ana</sub>	
4	n.c.	8	n.c.	
A4	AUX1	A8	AUX1	
A3	AUX1	A7	AUX1	

**Usable terminal modules**

Usable terminal modules for 2AO I High Feature (6ES7135-4MB02-0AB0)				
TM-E15C26-A1 (6ES7193-4CA50-0AA0)	TM-E15C24-A1 (6ES7193-4CA30-0AA0)	TM-E15C24-01 (6ES7193-4CB30-0AA0)	TM-E15C23-01 (6ES7193-4CB10-0AA0)	← Spring terminal
TM-E15S26-A1 (6ES7193-4CA40-0AA0)	TM-E15S24-A1 (6ES7193-4CA20-0AA0)	TM-E15S24-01 (6ES7193-4CB20-0AA0)	TM-E15S23-01 (6ES7193-4CB00-0AA0)	← Screw terminal
TM-E15N26-A1 (6ES7193-4CA80-0AA0)	TM-E15N24-A1 (6ES7193-4CA70-0AA0)	TM-E15N24-01 (6ES7193-4CB70-0AA0)	TM-E15N23-01 (6ES7193-4CB60-0AA0)	← Fast Connect
				<p>Sample connection</p>

Block diagram

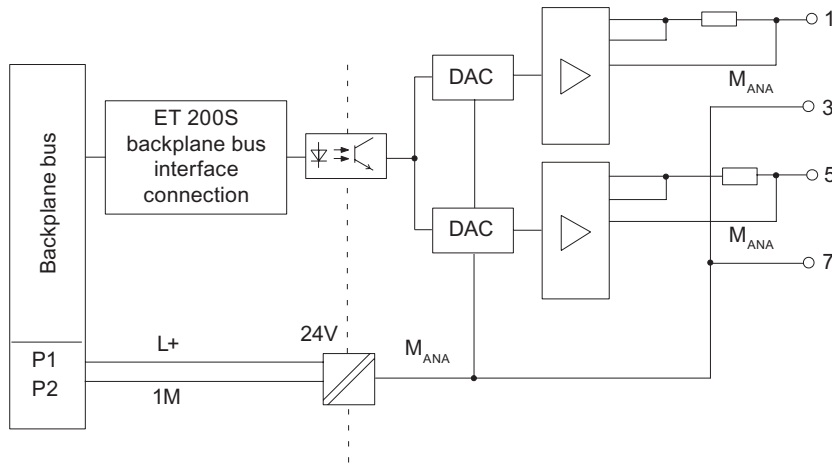

Figure 4-22 Block diagram of the 2AO I High Feature

2AO I High Feature Technical Specifications (6ES7135-4MB02-0AB0)

Dimensions and Weight	
Dimensions W × H × D (mm) (the total dimensions depend on the selected terminal module)	15 x 81 x 52
Weight	Approx. 40 g
Data for specific modules	
Supports isochronous operation	Yes
Number of outputs	2
Cable length	
• Shielded	max. 200 m
Parameter length	7 bytes
Voltages, currents, potentials	
Rated supply voltage of the electronics L+	24 VDC
• Reverse polarity protection	Yes
Galvanic isolation	
• Between the channels and backplane bus	Yes
• Between channels and power supply of the electronics	Yes
• Between the channels	no
Permissible potential difference	
• Between MANA and M <sub>internal</sub> (U <sub>ISO</sub> )	75 VDC / 60 VAC
Insulation tested	500 VDC
Current consumption	
• From the power supply L+	max. 150 mA
Power dissipation of the module	max. 2 W

<b>Status, interrupts, diagnostics</b>	
Diagnostics function	
• Group error display	Red "SF" LED
• Diagnostic information readable	Yes
Substitute values can be applied	Yes, parameterizable
<b>Analog value generation</b>	
Resolution (including sign)	± 20 mA/16 bits 4 to 20 mA/15 bits
Conversion time (per channel)	max. 1.0 ms
Settling time	
• For resistive load	0.25 ms
• For capacitive load	1.0 ms
• For inductive load	0.5 ms
<b>Suppression of interference, limits of error</b>	
Crosstalk between the outputs	> 60 dB
Operational limit (in the entire temperature range, with reference to the output range)	±0.07 % (at 250 Ω load impedance) ±0.3 % (for all other load impedances)
Basic error limit (operational limit at 25 °C with reference to output range)	±0.03 % (at 250 Ω load impedance) ±0.26 % (for all other load impedances)
Temperature error (with reference to the output range)	± 0.001 %/K
Linearity error (with reference to the output range)	± 0.02 %
Repeatability (in steady state at 25 °C with reference to output range)	± 0.01 %
Output ripple (with reference to output range, bandwidth 0 to 50 kHz)	± 0.02 %
<b>Data for selecting an actuator</b>	
Output range (rated value)	± 20 mA 4 to 20 mA
Load impedance (in the rated range of the output)	
• For current outputs For inductive load	max. 500 Ω 1 mH
Current output	
• Open circuit voltage	18 V
Destruction limit against voltages/currents applied from outside	
• Voltage at the outputs to M <sub>ANA</sub>	15 V continuous; 75 V for max. 1 ms (sampling ratio 1:20)
• Current	max. 50 mA DC
Connection of actuators	
• Current output Two-wire connection	supported









## 4 IQ-SENSE (6ES7138-4GA00-0AB0)

### 5.1 Features of 4 IQ-SENSE

#### Properties

The 4 IQ-SENSE has the following features:

- Connection of sensors with IQ-SENSE®, photoelectric proximity switches: for example, retro-reflective sensors, diffuse sensors, and laser sensors.
- You can connect up to 4 sensors to every module. Each sensor requires a two-wire cable.
- Excess gain and monitoring
- Time functions, switching hysteresis, synchronization groups that can be assigned parameters
- Sensitivity and distance values can be specified (*IntelliTeach* using the "IQ-SENSE Opto" FB)
- Teach-in
- Module can be removed and inserted during operation (restart the *Teach-in* using the "IQ-SENSE Opto" function block or the button on the sensor)
- Sensors can be removed and inserted during operation (automatic reassignment of parameters)
- Supports sensors with alignment tool
- The 4 IQ-SENSE is a single-width (15 mm) electronic module that can be used with the following terminal modules:
  - TM-E15S24-01, TM-E15C24-01 and TM-E15N24-01
  - TM-E15S26-A1, TM-E15C26-A1 and TM-E15N26-A1

**Parameter assignment**

You set the parameters for the 4 IQ-SENSE using the *STEP 7* parameter assignment software.

Configuration rules	
STEP 7 as of V5.1 SP3	With STEP 7 as of V5.0, Service Pack 3 or other configuration software
Contained in the hardware catalog of HW Config. A GSD file is not required.	IM151-1 BASIC: GSD file SIEM80F3.GSx as of 09/02 (as of V1.0)
	IM151-1 STANDARD: GSD file SIEM806A.GSx as of 10/01 (as of V1.10)
	IM151-1 FO STANDARD: GSD file SIEM806B.GSx as of 10/01 (as of V1.5)
	IM151-1 HIGH FEATURE: GSD file SIR380E0.GSx as of 12/01 (as of V1.0)
	IM151-3 PN (6ES7151-3AA10-0AB0)

**5.2 Parameters for the 4 IQ-SENSE**

**5.2.1 Parameters**

Table 5-1 Parameters for the 4 IQ-SENSE

Parameters	Range of values	Default setting	Applicability
Group diagnostics	<ul style="list-style-type: none"> <li>• Disable</li> <li>• Enable</li> </ul>	Disable	Module
Synchronization group	<ul style="list-style-type: none"> <li>• 1</li> <li>• 2</li> <li>• 3</li> <li>• 4</li> </ul>	1	Module
Sensor type	<ul style="list-style-type: none"> <li>• Retro-reflective sensor</li> <li>• Diffuse sensor</li> <li>• De-activated</li> </ul>	Retro-reflective sensor	Channel
Switching hysteresis	<ul style="list-style-type: none"> <li>• 5 %</li> <li>• 10 %</li> <li>• 20 %</li> <li>• 50 %</li> </ul>	20 %	Channel
Time functions	<ul style="list-style-type: none"> <li>• None</li> <li>• Return delay</li> <li>• Pickup delay</li> <li>• Pickup and return delay</li> <li>• Momentary impulse</li> </ul>	None	Channel

Parameters	Range of values	Default setting	Applicability
Time value	<ul style="list-style-type: none"> <li>• 5 ms</li> <li>• 10 ms</li> <li>• 20 ms</li> <li>• 50 ms</li> <li>• 100 ms</li> <li>• 200 ms</li> <li>• 500 ms</li> <li>• 1 s</li> <li>• 2 s</li> <li>• 5 s</li> <li>• 10 s</li> </ul>	5 ms	Channel
Teach-in disable	<ul style="list-style-type: none"> <li>• <i>Teach-in</i> with button possible</li> <li>• <i>Teach-in</i> with button not possible</li> </ul>	<i>Teach-in</i> with button possible	Channel

**Note**

Unused channels of the module must be deactivated otherwise the wire break diagnosis will be reported.

Measurement type parameter: **De-activated**

- All the diagnostics are suppressed.
- Sensitivity/distance values and circuit states are set to "0".
- The sensor is switched off.

## 5.2.2 Group diagnostics parameter

If group diagnostics is enabled, a pending diagnostics message is entered.

### Reference

Information on channel-related diagnostics can be found in the *ET 200S Operating Instructions*.

## 5.2.3 Synchronization group parameter

- Sensors between different modules of the 4 IQ-SENSE may influence one another (e.g. scattered light).
- To prevent interference from neighboring sensors on different modules, this parameter can be used to allocate a separate synchronization group to every module. Modules in different synchronization groups do not interfere with one another.
- Sensors on the same module cannot interfere with one another.

**Operating principle**

The diagram below explains the functioning of the synchronization group parameter:

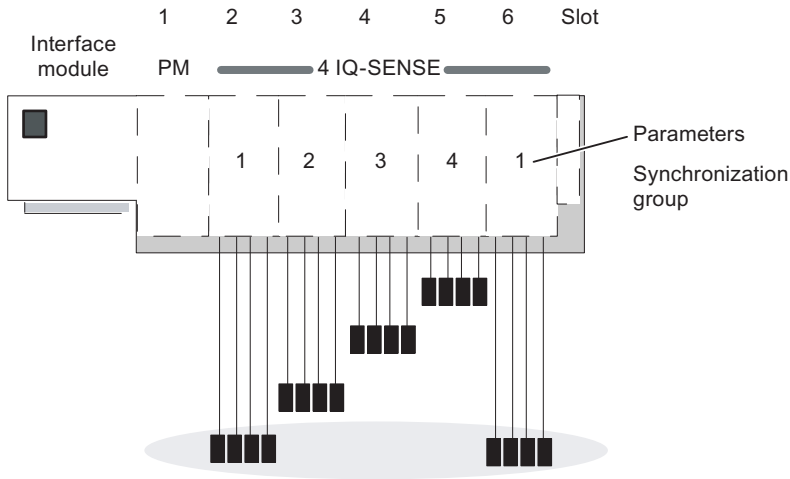

Figure 5-1 Synchronization group

Mutual interference is only possible between the sensors of the modules in slot 2 and 6, because they are in the same synchronization group 1.

**Note**

Sensors in the same synchronization group must be installed to maintain the minimum clearance (see sensor package insert) and to prevent mutual interference.

5.2.4 Sensor type parameter

This parameter is used to set the sensor type per channel:

- Retro-reflective sensor or
- Diffuse sensor or
- De-activated

Diffuse sensor

Table 5-2 Diffuse sensor

Diffuse sensor	Object	
Transmitter Receiver		Circuit state 0: no object detected, i.e. the object is not in the beam. The receiver does not detect light
Transmitter Receiver		Circuit state 1: object detected, i.e. the object is in the beam. The receiver does not detect light

Retro-reflective sensor

Table 5-3 Retro-reflective sensor

Retro-reflective sensor	Object	
Transmitter Receiver		Circuit state 0: no object detected, i.e. the object is not in the beam. The receiver detects light.
Transmitter Receiver		Circuit state 1: object detected, i.e. the object is in the beam. The receiver does not detect light

### 5.2.5 Switching hysteresis parameter

Faults with the diffuse sensor or in the production process can result in signal wobbles. The measured value then changes the switching threshold by 100 % (object detected - object not detected). You can prevent this switching threshold wobble using the switching hysteresis parameter. This will ensure a stable output signal on the sensor.

You can assigned parameters to 5 %/10 %/20 %/50 % for switching hysteresis.

#### Prerequisites

You can only set the switching hysteresis parameter for diffuse sensors with background fadeout.

#### Operating principle

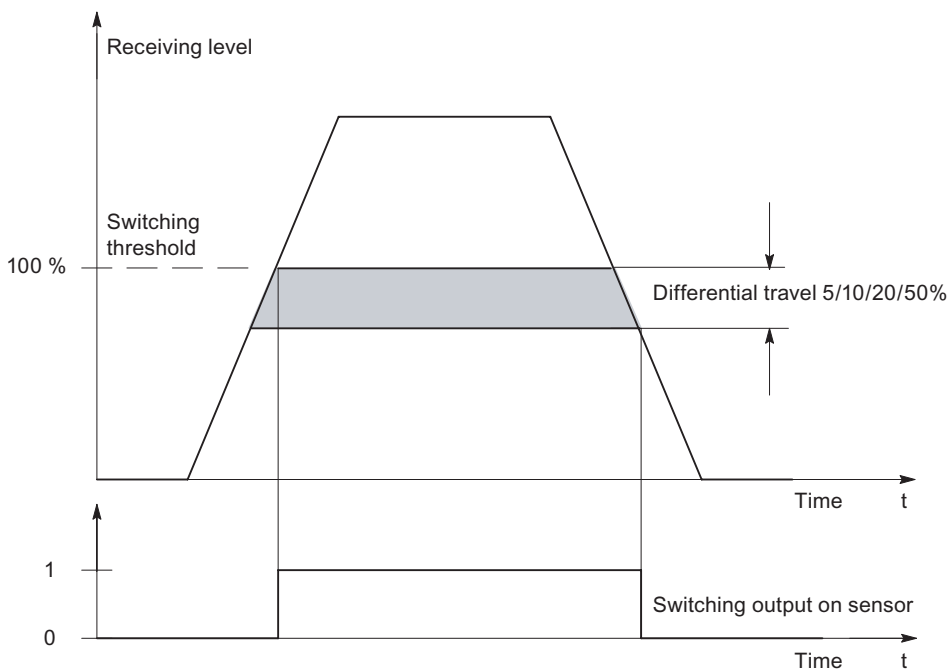

Figure 5-2 Switching hysteresis parameter



### 5.2.6 Time functions, time values parameters

These parameters can be used to set the electronic module for its specific application.

#### Operating principle

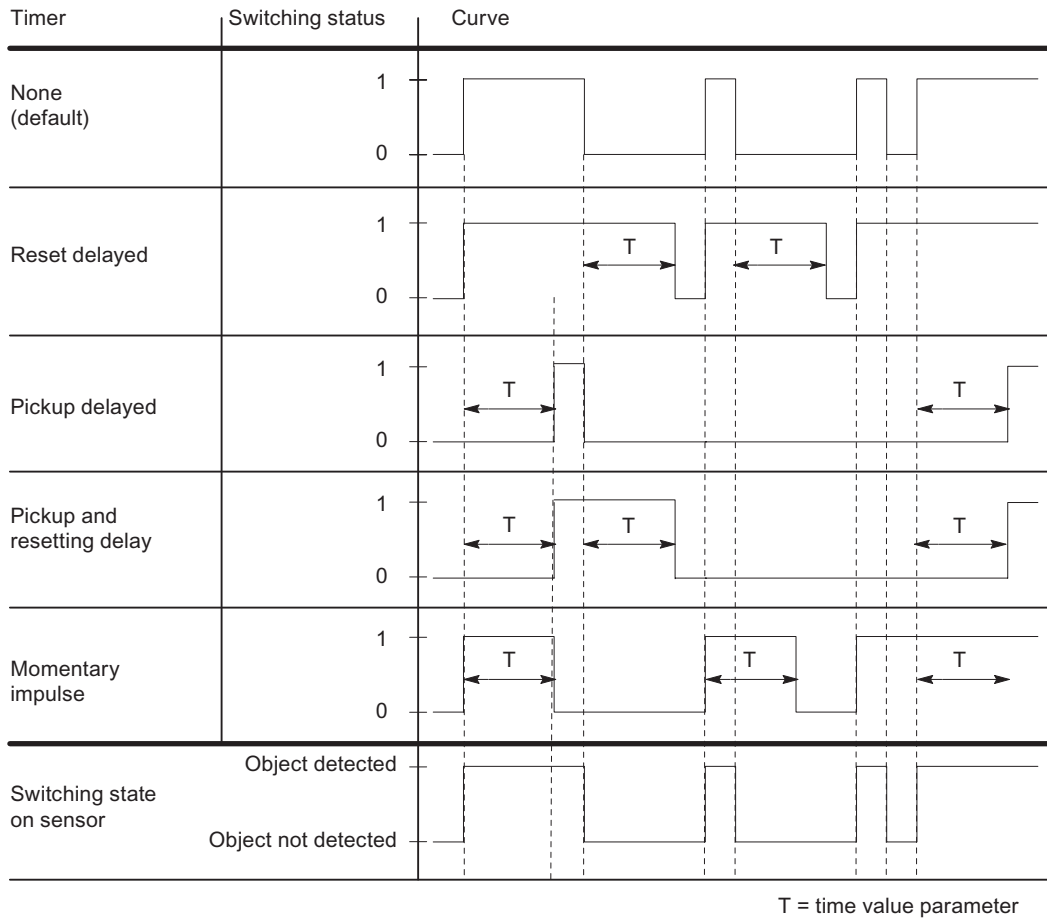

Figure 5-3 Time functions, time values parameters

### 5.2.7 Teach-in disable parameter

This parameter can be used to disable the *Teach in* button on the sensor.

## 5.3 Control interface (PIQ) and feedback interface (PII)

### 5.3.1 Basics of control interface (PIQ) and feedback interface (PII)

#### Introduction

You can configure the address space of the control and feedback interfaces of the 4 IQ-SENSE. You can choose between **Standard** and **Enhanced**.

#### Standard features

- The 4 IQ-SENSE occupies 4 bits in the feedback interface.
- You can evaluate the circuit state of each channel using the feedback interface.

#### Enhanced features

- The 4 IQ-SENSE occupies one byte in the control interface and one in the feedback interface.
- You can use the control interface to specify the sensitivity and distance values for each channel (*IntelliTeach* via "IQ-SENSE Opto" FB) and execute *Teach-in*.
- You can use the feedback interface to evaluate the acquired sensitivity and distance values (switching threshold) and the circuit state for each channel.

#### Requirements:

- You can use the "IQ-SENSE Opto" function block. The FB facilitates easy access to the control and feedback interface.
- Please note that in this case PII equals PIQ.
- You can download the function block and the relevant product information on the Internet at [http://www.ad.siemens.de/csi\\_e/gsd](http://www.ad.siemens.de/csi_e/gsd).

#### Configuring the address space

Address area	With STEP 7 as of V5.1, Service Pack 3	With STEP 7 as of V4.02 or COM PROFIBUS or other configuration software
Standard	In the hardware catalog of HW Config, choose <b>4 IQ-SENSE Opto S</b>	From the GSD file, choose <b>S 6ES7138-4GA00-0AB0 IQ-SENSE Opto</b>
Enhanced	In the hardware catalog of HW Config, choose <b>4 IQ-SENSE Opto E</b>	From the GSD file, choose <b>E 6ES7138-4GA00-0AB0 IQ-SENSE Opto</b>

5.3.2 Standard

Feedback interface (PII)

Table 5-4 Standard feedback interface

Address	Assignment	
Bytes 0	Bit 7:	0 (not assigned)
	Bit 6:	0 (not assigned)
	Bit 5:	0 (not assigned)
	Bit 4:	0 (not assigned)
	<b>bit 3:</b>	Circuit state sensor on channel 3 1: Object detected 0: Object not detected
	<b>Bit 2:</b>	Circuit state sensor on channel 2 1: Object detected 0: Object not detected
	<b>Bit 1:</b>	Circuit state sensor on channel 1 1: Object detected 0: Object not detected
	<b>bit 0:</b>	Circuit state sensor on channel 0 1: Object detected 0: Object not detected

5.3.3 Enhanced

Feedback interface (PII)

Table 5-5 Enhanced feedback interface

Address	Assignment		Designation on "IQ-SENSE Opto" FB
Bytes 0	<b>Bit 0:</b>	Circuit state sensor on channel 0 1: Object detected 0: Object not detected	Q_CH0
	<b>bit 1 to bit 7:</b>	Acquired sensitivity/distance value at channel 0 by <b>Teach in</b> <sup>1</sup>	TEACH_VAL_OUT
Bytes 1	<b>Bit 0:</b>	Circuit state sensor on channel 1 1: Object detected 0: Object not detected	Q_CH1
	<b>bit 1 to bit 7:</b>	Acquired sensitivity/distance value at channel 1 by <b>Teach in</b> <sup>1</sup>	TEACH_VAL_OUT
Bytes 2	<b>Bit 0:</b>	Circuit state sensor on channel 2 1: Object detected 0: Object not detected	Q_CH2
	<b>bit 1 to bit 7:</b>	Acquired sensitivity/distance value at channel 2 by <b>Teach in</b> <sup>1</sup>	TEACH_VAL_OUT
Bytes 3	<b>Bit 0:</b>	Circuit state sensor on channel 3 1: Object detected 0: Object not detected	Q_CH3
	<b>bit 1 to bit 7:</b>	Acquired sensitivity/distance value at channel 3 by <b>Teach in</b> <sup>1</sup>	TEACH_VAL_OUT
<sup>1</sup> The current sensitivity/distance value is entered: <ul style="list-style-type: none"> <li>- After teach-in is completed on the sensor</li> <li>- After teach-in is completed via the "IQ-SENSE Opto"</li> </ul>			

## Control interface (PIQ)

Table 5-6 Enhanced control interface

Address	Assignment	Designation on "IQ-SENSE Opto" FB
Bytes 0	<b>Specify sensitivity/distance value on channel 0</b> <ul style="list-style-type: none"> <li>• <b>bit 0:</b> 1: Transfer sensitivity/distance value to the sensor on channel 0 (using rising edge) 0: De-activated</li> <li>• <b>bit 1 to bit 7:</b> Specify sensitivity/distance value on channel 0: 1 to 126 (sensor-dependent)</li> </ul>	WR_TEACH_VAL  TEACH_VAL_IN
	<b>Teach-in on the sensor on channel 0</b> <ul style="list-style-type: none"> <li>• <b>bit 0:</b> 1: Start teach-in on the sensor on channel 0 (at the rising edge) 0: De-activated</li> <li>• <b>Bit 1 to 7: 0</b></li> </ul>	START_TEACH
Bytes 1	<b>Specify sensitivity/distance value on channel 1</b> <ul style="list-style-type: none"> <li>• <b>bit 0:</b> 1: Transfer sensitivity/distance value to the sensor on channel 1 (using rising edge) 0: De-activated</li> <li>• <b>bit 1 to bit 7:</b> Specify sensitivity/distance value on channel 1: 1 to 126 (sensor-dependent)</li> </ul>	WR_TEACH_VAL  TEACH_VAL_IN
	<b>Teach-in on the sensor on channel 1</b> <ul style="list-style-type: none"> <li>• <b>bit 0:</b> 1: Start teach-in on the sensor on channel 1 (at the rising edge) 0: De-activated</li> <li>• <b>Bit 1 to 7: 0</b></li> </ul>	START_TEACH
Bytes 2	<b>Specify sensitivity/distance value on channel 2</b> <ul style="list-style-type: none"> <li>• <b>bit 0:</b> 1: Transfer sensitivity/distance value to the sensor on channel 2 (using rising edge) 0: De-activated</li> <li>• <b>bit 1 to bit 7:</b> Specify sensitivity/distance value on channel 2: 1 to 126 (sensor-dependent)</li> </ul>	WR_TEACH_VAL  TEACH_VAL_IN
	<b>Teach-in on channel 2</b> <ul style="list-style-type: none"> <li>• <b>bit 0:</b> 1: Start teach-in on the sensor on channel 2 (at the rising edge) 0: De-activated</li> <li>• <b>Bit 1 to 7: 0</b></li> </ul>	START_TEACH

Address	Assignment	Designation on "IQ-SENSE Opto" FB
Bytes 3	<b>Specify sensitivity/distance value on channel 3</b> <ul style="list-style-type: none"> <li><b>bit 0:</b> 1: Transfer sensitivity/distance value to the sensor on channel 3 (using rising edge) 0: De-activated</li> <li><b>bit 1 to bit 7:</b> Specify sensitivity/distance value on channel 3: 1 to 126 (sensor-dependent)</li> </ul>	WR_TEACH_VAL  TEACH_VAL_IN
	<b>Teach-in on the sensor on channel 3</b> <ul style="list-style-type: none"> <li><b>bit 0:</b> 1: Start teach-in on the sensor on channel 3 (at the rising edge) 0: De-activated</li> <li><b>Bit 1 to 7: 0</b></li> </ul>	START_TEACH

**Principle of operation: Specifying a sensitivity/distance value (IntelliTeach)**

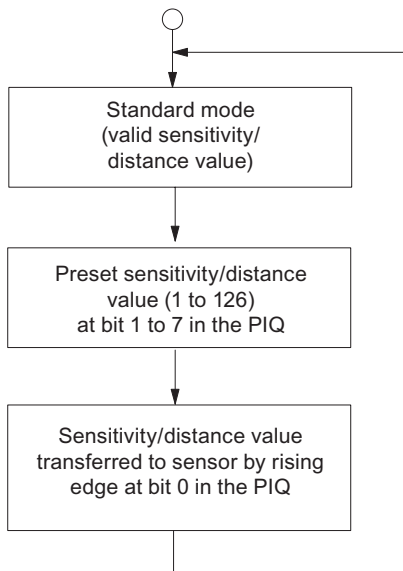

Figure 5-4 Principle of operation: Specifying a sensitivity/distance value (IntelliTeach)

Principle of operation: Teach-in

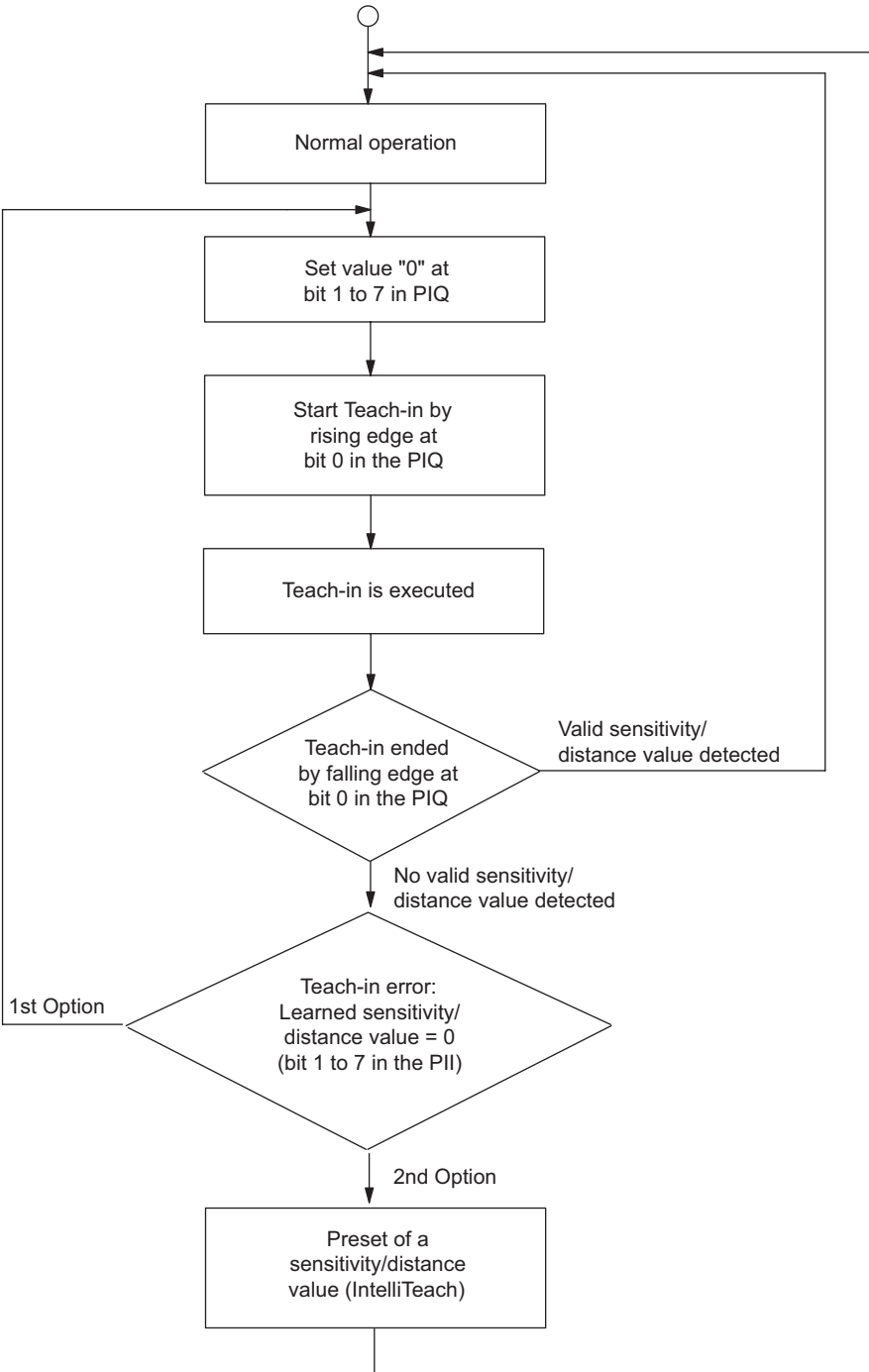

Figure 5-5 Principle of operation: Teach-in

## 5.4 Technical Specifications

### General terminal assignment

**Note**

Terminals A4, A8, A3 and A7 are only available at specified terminal modules.

Terminal assignment for 4 IQ-SENSE (6ES7138-4GA00-0AB0)				
Terminal	Assignment	Terminal	Assignment	Notes
1	M <sub>0+</sub>	5	M <sub>1+</sub>	<ul style="list-style-type: none"> <li>M<sub>n+</sub>: Input signal "+", channel n</li> <li>M<sub>n-</sub>: Input signal "-", channel n</li> <li>AUX1: Protective-conductor terminal or potential bus (freely usable up to 230 VAC)</li> </ul>
2	M <sub>2+</sub>	6	M <sub>3+</sub>	
3	M <sub>0-</sub>	7	M <sub>1-</sub>	
4	M <sub>2-</sub>	8	M <sub>3-</sub>	
A4	AUX1	A8	AUX1	
A3	AUX1	A7	AUX1	

### Usable terminal modules

Usable terminal modules for 4 IQ-SENSE (6ES7138-4GA00-0AB0)		
TM-E15C26-A1 (6ES7193-4CA50-0AA0)	TM-E15C24-01 (6ES7193-4CB30-0AA0)	← Spring terminal
TM-E15S26-A1 (6ES7193-4CA40-0AA0)	TM-E15S24-01 (6ES7193-4CB20-0AA0)	← Screw terminal
TM-E15N26-A1 (6ES7193-4CA80-0AA0)	TM-E15N24-01 (6ES7193-4CB70-0AA0)	← Fast Connect
		Sample connection 



**Note**

The terminals to the sensors are protected against polarity reversal.

The maximum wire cross-section for the sensors is 0.25 mm<sup>2</sup>.

Connection cables for the sensors can be found in the *ET 200S Operating Instructions in the section with order numbers.*

**Block diagram**

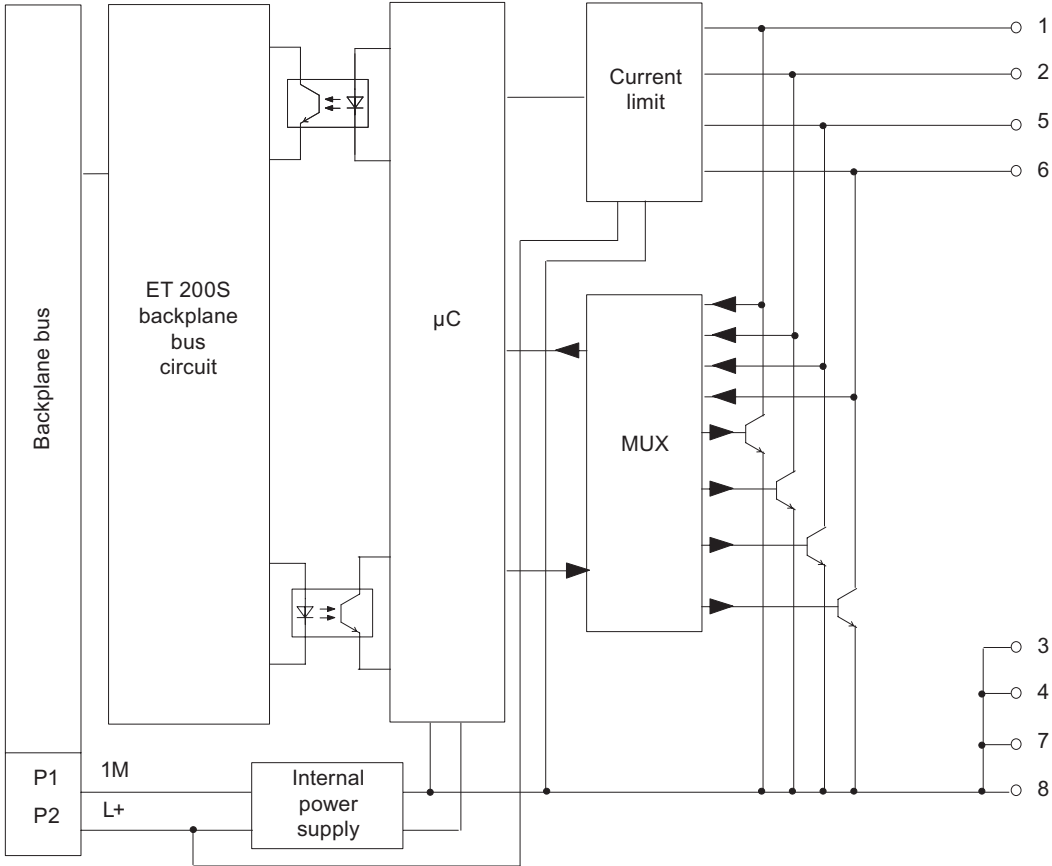

Figure 5-6 Block diagram of the 4 IQ-SENSE

4 IQ-SENSE Technical Specifications (6ES7138-4GA00-0AB0)

<b>Dimensions and Weight</b>	
Dimensions W x H x D (mm)	15 x 81 x 52
Weight	Approx. 35 g
<b>Data for specific modules</b>	
Supports isochronous operation	no
Number of inputs	4
Cable length	
• Unshielded	max. 50 m
• Shielded	max. 50 m
Parameter length	16 bytes
<b>Voltages, currents, potentials</b>	
Rated supply voltage (from the power module)	24 VDC
• Reverse polarity protection	Yes
Galvanic isolation	
• Between the channels	no
• Between the channels and backplane bus	Yes
Permissible potential difference	
• Between the different circuits	75 VDC / 60 VAC
Insulation test voltage	500 VDC
Current consumption	
• From supply voltage	max. 0.3 A
Power dissipation of the module	Typically 0.85 W
<b>Status, interrupts, diagnostics</b>	
Status display	Green LED per channel
Diagnostics function	
• Group error	Red "SF" LED
• Diagnostic information can be displayed	Yes
<b>Data for selecting a sensor</b>	
Connectable sensors	Photoelectric proximity switches with IQ-Sense
<b>Response Times</b>	
Cycle time	max. 3.24 ms

**Reference**

For information on the order numbers for connection cables for the 4 IQ-SENSE electronic modules see the *section on order numbers* in the *ET 200S Operating Instructions*.

## RESERVE modules

### Properties

The RESERVE module has the following characteristic features:

- Suitable for all TM-E terminal modules (installation widths 15 mm and 30 mm).
- reserved for a slot on any electronic module.  
Insert the RESERVE module in the reserved slot of the ET 200S configuration.

---

#### Note

Pay attention to the following with the IM151 (6ES7151-1AA01-0AB0, 6ES7151-1AA02-0AB0), IM 151 FO (6ES7151-1AB00-0AB0, 6ES7151-1AB01-0AB0) and IM151/CPU (6ES7151-7AA00-0AB0):

- If you remove an electronic module during operation of the ET 200S and replace it with a RESERVE module, you must then cycle the supply voltage (power OFF/power ON) on the interface module.

Pay attention to the following with the IM151 (6ES7151-1AA00-0AB0):

- The RESERVE module cannot be used in the ET 200S.
- 

### Parameter assignment (without option handling)

- In *STEP 7* or *COM PROFIBUS*, assign parameters to the electronic module you want to use for future applications, such as 4DI 24 VDC High Feature, on the slot of the RESERVE module.
  - Drag the module to the configuration table
  - Assign the parameters
- Parameterize the interface module as follows:

Parameters	Setting
Operation at Preset <> Actual Configuration	Enable

- If you have assigned parameters to an electronic module with inputs for the RESERVE module, the following substitute values are reported:
  - Digital input modules:0
  - Analog input modules: 7FFF<sub>H</sub>
  - Function module:0

**Note**

If you use RESERVE modules:

- The SF LED lights up on the interface module
  - A channel-specific diagnostic and module status "10<sub>B</sub>: Wrong module" are reported for the RESERVE module slot.
- 

**Pin assignment**

The RESERVE module has no connection to the terminals of the TM-E terminal module. This enables you to fully wire the TM-E terminal module and prepare it for the subsequent application.

**RESERVE Module Technical Specifications (6ES7138-4AAx1-0AA0)**

Dimensions and Weight	
Dimension W x H x D (mm)	15 x 81 x 52 30 x 81 x 52
Weight	Approx. 33 g (installation width 15 mm) Approx. 55 g (installation width 30 mm)
Voltages, currents, potentials	
Power dissipation of the module	Typically 0.025 W
Status, interrupts, diagnostics	
Status display	no
Diagnostics function	no

**Note**

The address space must correspond with the address space of the planned electronic module.

---

**Reference**

For information on the option handling and implementation of RESERVE modules can be found in the *ET 200S Operating Instructions* in *Functions > Option Handling on the PROFIBUS DP*.

# Glossary

## Aggregate current

The sum of the currents of all the output channels of a digital output module.

## AUX1 bus

Power modules permit you to connect additional potential (up to 230 VAC), which you can apply by means of the AUX(iiliary) bus. You can set the AUX(iiliary) bus individually:

- As a protective conductor bar
- Additionally required voltage

## Backplane bus

The backplane bus is a serial data bus via which the IM151-1 interface communicates with the electronic modules/motor starters, supplying them with the required voltage. The connection between the individual modules is established by means of the terminal modules.

## Bus

A common transfer route connecting all nodes and having two defined ends.

In the case of the ET 200, the bus is a two-wire or fiber-optic cable.

## Bus connector

A physical connection between the bus nodes and the bus line.

## Chassis ground

Chassis ground refers to all the interconnected inactive parts of a piece of equipment that, even in the event of a fault, cannot carry voltage that is dangerous to the touch.

## Configuration

The systematic arrangement of the different ET 200S modules (setup).

## Connecting to common potential

The opening of a new potential group by a power module. This permits the individual grouping of the sensor and load supplies.

## Device names

Before an IO device can be addressed by an IO controller, it must have a device name. This procedure was selected for PROFINET because names are easier to handle than complex IP addresses.

Assignment of a device name for a concrete IO device can be compared with the setting of the PROFIBUS address for a DP slave.

An IO device does not have a device name upon delivery. An IO device can only be addressed by an IO controller - i.e., for transferring configuration data (including the IP address) during startup or for user data exchange during cyclic operation - after it has been assigned a device name with the programming device/PC.

## Diagnostics

Diagnostics involves the identification, localization, classification, display, and further evaluation of errors, faults, and messages.

Diagnostics includes monitoring functions that run automatically while the system is in operation. This increases the availability of systems by reducing setup times and downtimes.

## Direct starter

A direct starter is a → motor starter that switches a motor on or off directly. It consists of a circuit breaker and a contactor.

## Distributed IO systems

These are input/output units that are not located in the base unit; instead, they are distributed at some distance from the CPU.

- The following are examples of such units:
- ET 200M, ET 200X, ET 200L, ET 200S DP/AS-i Link
- S5-95U with PROFIBUS DP slave interface
- Other DP slaves from either Siemens or other vendors

The distributed IO systems are connected to the DP master by means of PROFIBUS DP.

## DP master

A → master that complies with the standard IEC 61784-1:2002 Ed1 CP 3/1 is known as a DP master.

## DP slave

A → slave running on the PROFIBUS on the basis of the PROFIBUS DP protocol in accordance with IEC 61784-1:2002 Ed1 CP 3/1 is known as a DP slave.

## DP standard

The DP standard is the bus protocol of the ET 200 distributed IO system in accordance with IEC 61784-1:2002 Ed1 CP 3/1.

## Equipotential bonding

Electrical connection (equipotential bonding conductor) that brings the exposed conductive parts of electrical equipment and other conductive parts to the same or approximately the same potential in order to prevent troublesome or dangerous voltages arising between these parts.

## ET 200

The ET 200 distributed IO system with the PROFIBUS DP protocol enables distributed IO devices to be connected to a CPU or an appropriate DP master. A feature of the ET 200 is its fast response times, since only a small amount of data (bytes) is transferred.

The ET 200 is based on IEC 61784-1:2002 Ed1 CP 3/1.

The ET 200 works on the master/slave principle. Examples of DP masters are the IM308-C master interface or the CPU 315-2 DP.

DP slaves can be the distributed IO devices ET 200M, ET 200X, ET 200L, or ET 200S or DP slaves from Siemens or other vendors.

## FREEZE

This is a control command of the DP master to a group of DP slaves.

When a DP slave receives the FREEZE control command, it freezes the current status of the **inputs** and transfers them cyclically to the DP master.

After each subsequent FREEZE control command, the DP slave freezes the status of the **inputs** again.

The input data is not transferred from the DP slave to the DP master again cyclically until the DP master sends the UNFREEZE control command.

## Ground

The conductive mass of earth, the electrical potential of which is equivalent to zero. In the vicinity of grounding electrodes, the potential may not be zero. The term "reference ground" is often used here.

## Grounding

Grounding means connecting an electrically conductive part to a grounding electrode by means of a grounding system.

## GSD file

The properties of a PROFINET device are described in a GSD (General Station Descriptor) file that contains all required information for configuration.

As with PROFIBUS, you can link a PROFINET device in STEP 7 by means of a GSD file.

In PROFINET IO, the GSD file is always in XML format. The structure of the GSD file corresponds to ISO 15734, the worldwide standard for device descriptions.

In PROFIBUS, the GSD file is in ASCII format (as defined in IEC 61784-1:2002 Ed1 CP 3/1).

### Hot swapping

This is the removal and insertion of modules during the operation of the ET 200S.

### Isolated

In the case of isolated input/output modules, the reference potentials of the control and load circuit are galvanically isolated - for example, by means of optical isolators, relays, or transformers. Input/output circuits can be grouped.

### MAC address

Each PROFINET device has a factory-assigned worldwide unique device identification. This 6-byte device identification is the MAC address.

The MAC address consists of:

- 3-byte manufacturer ID
- 3-byte device ID (serial number)

As a rule, the MAC address can be read on the front of the device, e. g.: 08-00-06-6B-80-C0

### Master

When it has a token, a master can send data to and request data from other nodes (= active participants). Examples of DP masters are the CPU 315-2 DP or the IM308-C.

### Motor starter (MS)

Motor starter is the generic term for → direct and → reversing starters. The startup and direction of rotation of a motor are determined by motor starters.

### Node

A device that can send, receive, or repeat data on the bus for example, a DP master, DP slave, or RS 485 repeater.

### Non-isolated

In the case of non-isolated input/output modules, the reference potentials of the control and load circuits are electrically connected.

### Parameter assignment

Parameter assignment is the transfer of slave parameters from the DP master to the DP slave.

### PELV

Protective Extra Low Voltage = extra low voltage with safe isolation



**Power buses (P1/ P2)**

Two internal buses (P1 and P2) that supply the electronic modules with voltage. The power buses are fed by the power module and connected by means of the terminal modules.

**Prewiring**

The wiring of the terminal modules before the electronic modules are inserted.

**Process image**

The process image is a component of the system memory of the DP master. The signal states of the input modules are transferred to the process-image input area at the beginning of the cyclic program. At the end of the cyclic program, the values of the process-image output area are transferred to the DP slave as the signal states.

**PROFIBUS**

PROcess Field BUS, process field bus standard specified in IEC 61784-1:2002 Ed1 CP 3/1. It defines functional, electrical, and mechanical properties for a bit-serial field bus system.

PROFIBUS is available with the protocols DP (which stands for distributed peripherals, that is, distributed or remote IO), FMS (which stands for field bus message specification), PA (= process automation), or TF (= technological functions).

**PROFIBUS address**

Each bus node must receive a PROFIBUS address to identify it uniquely on the PROFIBUS.

The PC/programming device has the PROFIBUS address "0".

The PROFIBUS addresses 1 to 125 are permitted for the ET 200S distributed IO system.

**PROFINET**

Within the context of Totally Integrated Automation (TIA), PROFINET is the systematic development of the following systems:

- PROFIBUS DP, the established field bus
- Industrial Ethernet, the communication bus for the cell level

Experiences from both systems have been and are being integrated in PROFINET.

PROFINET as the Ethernet-based automation standard of PROFIBUS International (formerly PROFIBUS Nutzerorganisation e.V.) defines a cross-vendor communication, automation, and engineering model.

## **PROFINET component**

A PROFINET component includes all data of the hardware configuration, the parameters of the modules, and the associated user program. The PROFINET component comprises the following elements:

- Technological function

The (optional) technological (software) function includes the interface to other PROFINET components as interconnectable inputs and outputs.

- Device

The device represents the physical automation device or field device, including the IO, sensors and actuators, mechanical system, and device firmware.

## **PROFINET device**

A PROFINET device always has at least one Industrial Ethernet connection. In addition, a PROFINET device can also have a PROFIBUS connection and even act as a master with proxy functionality. In exceptional cases, a PROFINET device can also have several PROFIBUS connections (e. g. CP 5614).

## **PROFINET IO**

Within the context of PROFINET, PROFINET IO is a communication concept for implementing modular, distributed applications.

With PROFINET IO, you can create automation solutions using the trusted and familiar methods of PROFIBUS.

PROFINET IO is implemented with the PROFINET standard for automation devices on the one hand and the STEP 7 engineering tool on the other hand.

This means that you have the same application layer in STEP 7 - regardless of whether you configure PROFINET devices or PROFIBUS devices. The programming of your user program is identical for PROFINET IO and PROFIBUS DP when you use the blocks and system status lists expanded for PROFINET IO.

## **PROFINET IO controller**

Device by means of which connected IO devices are addressed. This means: that the IO controller exchanges input and output signals with assigned field devices. The IO controller is often the controller in which the automation program is executed.

## **PROFINET IO device**

Distributed field device assigned to one of the IO controllers (e.g. remote IO, valve terminals, frequency converters, or switches).

## **Programmable controller**

An automation system is a programmable logic controller consisting of at least one CPU, various input and output modules, and operator control and monitoring devices.

**Provider-consumer principle**

Unlike PROFIBUS DP, both partners on PROFINET IO are independent providers for transmission of data.

**Real time**

Real time means that a system processes external events within a defined time.

Determinism means that a system responds in a predictable (deterministic) manner.

Both requirements are important for industrial networks. PROFINET satisfies these requirements. Thus, as a deterministic real-time network, PROFINET is designed as follows:

- The transfer of time-critical data between different stations via a network is guaranteed within a defined interval of time.
- To this end, PROFINET has an optimized communication channel for real-time communication: Real time (RT).
- The time of transfer can be accurately determined.
- It is ensured that seamless communication can take place in the same network by means of other standard protocols, such as industrial communication for PG/PC.

**Reference data companions**

A value is assigned to every peripheral module in the input or output data telegram which gives evidence about the quality of this reference date. For example outputs of a module can thus be switched off without influencing other modules.

**Reference potential**

Potential from which the voltages of the circuits involved can be observed and/or measured.

**Reversing starter**

A reversing starter is a → motor starter that determines the direction of rotation of a motor. It consists of a circuit breaker and two contactors.

**Segment**

The bus line between two terminating resistors forms a segment. A segment contains 0 to 32 → bus nodes. Segments can be interconnected by means of RS 485 repeaters.

**SELV**

**Safety Extra Low Voltage**

**Slave**

A slave can only exchange data with a → master when requested by it to do so. By slaves we mean, for example, all DP slaves such as ET 200X, ET 200M, ET 200S, etc.

## SNMP

SNMP (Simple Network Management Protocol) is the standardized protocol for performing diagnostics and assigning parameters to the Ethernet network infrastructure.

In the office setting and in automation engineering, devices from many different vendors support SNMP on the Ethernet.

SNMP-based applications can be operated on the same network in parallel to applications with PROFINET.

The scope of supported functions depends on the device type. For example, a switch has more function than a CP 1616.

## SSI

The positional information is transferred synchronously on the basis of the SSI (synchronous serial interface) protocol. The SSI protocol is used with absolute encoders.

## Stationary wiring

All the wiring-carrying elements (terminal modules) are mounted on a rail. The power and electronic modules are inserted in the terminal modules.

## Switch

PROFIBUS is a linear network. The communication nodes are linked by means of a passive cable– the bus.

By contrast, Industrial Ethernet consists of point-to-point connections: each communication node is directly connected to exactly one communication node.

If a communication node is linked to several communication nodes, this communication node is connected to the port of an active network component – the switch. Additional communication nodes (including switches) can now be connected to the other ports of the switch. The connection between a communication node and the switch remains a point-to-point connection.

A switch also has the task of regenerating and distributing received signals. The switch "learns" the Ethernet address(es) of a connected PROFINET device or additional switches and only forwards those signals that are intended for the connected PROFINET device or switch.

A switch has a specific number of ports. You connect at most one PROFINET device or additional switch to each port.

## SYNC

This is a control command of the DP master to a group of DP slaves.

By means of the SYNC control command, the DP master causes the DP slave to freeze the current statuses of the outputs. With the subsequent frames, the DP slave stores the output data, but the statuses of the outputs remain unchanged.

After each new SYNC control command, the DP slave sets the outputs that it has stored as output data. The outputs are not cyclically updated again until the DP master sends the UNSYNC control command.

**Technological modules**

Modules that are equipped with technological functions, such as counting pulses, positioning, and controlling stepping motor power units.

**Terminating module**

The ET 200S distributed IO system is completed by the terminating module. If you have not inserted a terminating module, the ET 200S is not ready for operation.

**Transmission rate**

The transmission rate of a data transfer is measured in bits transmitted per second. In the case of the ET 200S, transmission rates of 9.6 kbps to 12 Mbps are possible.

**Voltage group**

A group of electronic modules supplied by a power module.



# Index

## 2

2RO NO 24 to 48 VDC/5A, 24 VAC to 230 VAC/5 A digital electronic module

Switching capacity and lifetime of the contacts, 3-86

2RO NO 24 VDC to 120 VDC/5 A, 24 VAC to 230 VAC/5 A digital electronic module

Switching capacity and lifetime of the contacts, 3-81

Technical Specifications, 3-79

2RO NO 24 VDC to 48 VDC/5 A, 24 VAC to 230 VAC/5 A digital electronic module

Block diagram, 3-83

Pin assignment, 3-82

Properties, 3-82

Technical Specifications, 3-84

2RO NO 24-120 VDC/5 A, 24-230 VAC/5 A digital electronic module

Block diagram, 3-79

Pin assignment, 3-77

Properties, 3-77

## 4

4DI 24 to 48 VUC High Feature digital electronic module

Block diagram, 3-29

Properties, 3-27

Technical Specifications, 3-29

4-wire transducer, 4-17

## A

Address space, 2-8

Analog electronic module 2AI I 2/4WIRE High Feature

Block diagram, 4-66

Pin assignment, 4-65

Properties, 4-65

Technical Specifications, 4-67

Analog electronic module 2AI I 2WIRE High Speed

Block diagram, 4-58

Pin assignment, 4-57

Properties, 4-57

Technical Specifications, 4-59

Analog electronic module 2AI I 2WIRE Standard

Block diagram, 4-50

Pin assignment, 4-49

Properties, 4-49

Technical Specifications, 4-51

Analog electronic module 2AI I 4WIRE High Speed

Block diagram, 4-70

Pin assignment, 4-69

Properties, 4-69

Technical Specifications, 4-71

Analog electronic module 2AI I 4WIRE Standard

Block diagram, 4-62

Pin assignment, 4-61

Properties, 4-61

Technical Specifications, 4-63

Analog electronic module 2AI RTD High Feature

Block diagram, 4-79

Pin assignment, 4-78

Properties, 4-77

Technical Specifications, 4-80

Analog electronic module 2AI RTD Standard

Block diagram, 4-75

Pin assignment, 4-73

Properties, 4-73

Technical Specifications, 4-75

Analog electronic module 2AI TC High Feature

Block diagram, 4-91

Pin assignment, 4-91

Properties, 4-90

Technical Specifications, 4-92

Analog electronic module 2AI TC Standard

Block diagram, 4-87

Pin assignment, 4-86

Properties, 4-85

Technical Specifications, 4-87

Analog electronic module 2AI U High Feature

Block diagram, 4-42

Pin assignment, 4-41

Properties, 4-41

Technical Specifications, 4-43

- Analog electronic module 2AI U High Speed
  - Block diagram, 4-46
  - Pin assignment, 4-45
  - Properties, 4-45
  - Technical Specifications, 4-47
- Analog electronic module 2AI U Standard
  - Block diagram, 4-38
  - Pin assignment, 4-37
  - Properties, 4-37
  - Technical Specifications, 4-39
- Analog electronic module 2AO I High Feature
  - Block diagram, 4-108
  - Pin assignment, 4-107
  - Properties, 4-106
  - Technical Specifications, 4-108
- Analog electronic module 2AO I Standard
  - Block diagram, 4-104
  - Pin assignment, 4-103
  - Properties, 4-103
  - Technical Specifications, 4-105
- Analog electronic module 2AO U High Feature
  - Block diagram, 4-100
  - Pin assignment, 4-99
  - Properties, 4-99
  - Technical Specifications, 4-101
- Analog electronic module 2AO U Standard
  - Block diagram, 4-97
  - Pin assignment, 4-96
  - Properties, 4-95
  - Technical Specifications, 4-97
- Analog electronic module 4AI I 2WIRE ST
  - Block diagram, 4-54
  - Pin assignment, 4-53
  - Properties, 4-53
  - Technical Specifications, 4-55
- Analog electronic modules, 4-1
- Analog Input Modules, 4-15
- Analog Output Modules, 4-15
- Analog output modules in SIMATIC S7 format, 4-13
- Analog value processing, 4-14
- Analog value representation, 4-1, 4-14
  - for resistance thermometers, 4-6, 4-7, 4-8, 4-9
  - for thermocouples, 4-9, 4-10, 4-11, 4-12, 4-13
- AUX(iliary) bus (AUX1), 2-12

## B

- Behavior of the analog modules, 4-24
  - During operation, 4-24
  - In the event of faults, 4-24

## C

- Compensation of the reference junction temperature, 4-18
- Configuration examples
  - Terminal modules for power modules, 2-14
- Connecting, 4-14, 4-18
- Connecting measuring sensors to analog inputs, 4-15
- Connecting to common potential, 2-12

## D

- Digital electronic module 2DI 120 VAC Standard
  - Block diagram, 3-43
  - Pin assignment, 3-42
  - Properties, 3-42
  - Technical Specifications, 3-44
- Digital electronic module 2DI 230 VAC Standard
  - Block diagram, 3-46
  - Pin assignment, 3-45
  - Properties, 3-45
  - Technical Specifications, 3-47
- Digital electronic module 2DI 24 VDC High Feature
  - Block diagram, 3-21
  - Pin assignment, 3-19
  - Properties, 3-19
  - Technical Specifications, 3-21
- Digital electronic module 2DI 24 VDC Standard
  - Block diagram, 3-10
  - Pin assignment, 3-8
  - Properties, 3-8
  - Technical Specifications, 3-10
- Digital electronic module 2DO 24 VDC/0.5 A High Feature
  - Block diagram, 3-58
  - Pin assignment, 3-56
  - Properties, 3-56
  - Technical Specifications, 3-59
- Digital electronic module 2DO 24 VDC/0.5 A Standard
  - Block diagram, 3-50
  - Pin assignment, 3-48
  - Properties, 3-48
  - Technical Specifications, 3-50
- Digital electronic module 2DO 24 VDC/2 A High Feature
  - Block diagram, 3-70
  - Pin assignment, 3-68
  - Properties, 3-68
  - Technical Specifications, 3-71



## Digital electronic module 2DO 24 VDC/2 A Standard

- Block diagram, 3-62
- Pin assignment, 3-61
- Properties, 3-60
- Technical Specifications, 3-62

## Digital electronic module 2DO 24-230 VAC

- Block diagram, 3-74
- Pin assignment, 3-73
- Properties, 3-73
- Technical Specifications, 3-75

## Digital electronic module 4DI 24 VDC High Feature

- Block diagram, 3-25
- Pin assignment, 3-23
- Properties, 3-23
- Technical Specifications, 3-25

## Digital electronic module 4DI 24 VDC Standard

- Block diagram, 3-14
- Pin assignment, 3-12
- Properties, 3-12
- Technical Specifications, 3-14

## Digital electronic module 4DI 24 VDC/SRC Standard

- Block diagram, 3-17
- Pin assignment, 3-16
- Properties, 3-15
- Technical Specifications, 3-17

## Digital electronic module 4DI NAMUR

- Block diagram, 3-38
- Pin assignment, 3-31
- Properties, 3-31
- Technical Specifications, 3-38

## Digital electronic module 4DO 24 VDC/0.5 A Standard

- Block diagram, 3-54
- Pin assignment, 3-52
- Properties, 3-52
- Technical Specifications, 3-54

## Digital electronic module 4DO 24 VDC/2 A Standard

- Block diagram, 3-66
- Pin assignment, 3-64
- Properties, 3-64
- Technical Specifications, 3-66

## I

- Interference frequency suppression, 4-35
- Isolated measuring sensors, 4-16

## L

- Lines for analog signals, 4-14

## M

- Measurement resolution, 4-3
- Measuring range with SIMATIC S7, 4-2
- Measuring sensors, 4-14

## N

- Non-isolated measuring sensors, 4-17

## O

- Output ranges, 4-13

## P

- Parameter assignment of the reference junction, 4-21
- Parameters
  - for 4DI NAMUR, 3-2
  - for analog electronic modules, 4-26
  - for digital input modules, 3-1
  - for digital output modules, 3-3
  - For power modules, 2-2
- Placing and Connecting to Common Potential, 2-12
- Placing power modules and connecting them to common potential, 2-12
- PM-E 24 to 48 VDC/24 to 230 VAC power module
  - Block diagram, 2-11
  - Pin assignment, 2-10
  - Properties, 2-9, 6-2
- PM-E 24 VDC power module
  - Block diagram, 2-5
  - Pin assignment, 2-4
  - Properties, 2-3
  - Technical Specifications, 2-5
- PM-E 24 VDC to 48 VDC power module
  - Block diagram, 2-7
  - Pin assignment, 2-6
  - Properties, 2-6
  - Technical Specifications, 2-8
- PM-E 24 VDC to 48 VDC/24 VAC to 230 VAC power module
  - Technical Specifications, 2-11
- Power modules
  - Parameters, 2-2
- Power supply, 2-12

## S

- Shield contact, 4-26
- Smoothing, 4-34

## T

Terminal module TM-E15S24-01, TM-E15C24-01, and TM-E15N24-01

Block diagram, 1-11

Properties, 1-11

Technical Specifications, 1-12

Terminal module TM-E15S24-AT and TM-E15C24-AT

Block diagram, 1-14

Properties, 1-13

Technical Specifications, 1-14

Terminal module TM-E30S46-A1 and TM-E30C46-A1

Block diagram, 1-15

Properties, 1-5, 1-15

Technical Specifications, 1-16

Terminal module TM-PF30S47-F1

Block diagram, 1-7

Properties, 1-7

Technical Specifications, 1-8

Terminal modules TM-E15S23-01, TM-E15C23-01, and TM-E15N23-01

Block diagram, 1-12

Properties, 1-12

Technical Specifications, 1-13

Terminal modules TM-E15S24-A1, TM-E15C24-A1, and TM-E15N24-A1

Block diagram, 1-10

Properties, 1-9

Technical Specifications, 1-10

Terminal modules TM-E15S26-A1, TM-E15C26-A1, and TM-E15N26-A1

Block diagram, 1-8

Properties, 1-8

Technical Specifications, 1-9

Terminal modules TM-P15S22-01, TM-P15C22-01, and TM-P15N22-01

Block diagram, 1-4

Properties, 1-4

Technical Specifications, 1-5

Terminal modules TM-P15S23-A0, TM-P15C23-A0, and TM-P15N23-A0

Block diagram, 1-3

Properties, 1-3

Technical Specifications, 1-4

Terminal modules TM-P15S23-A1, TM-P15C23-A1, and TM-P15N23-A1

Block diagram, 1-2

Properties, 1-1

Technical Specifications, 1-2

TE-U120S4x10 and TE-U120C4x10 supplementary module

Properties, 1-19

Technical Specifications, 1-20

Thermocouples, 4-18

TM-C120S and TM-C120C terminal modules

Block diagram, 1-18

Properties, 1-18

Technical Specifications, 1-18

TM-E30S44-01 and TM-E30C44-01 terminal modules

Block diagram, 1-6, 1-17

Properties, 1-17

Technical Specifications, 1-6, 1-17

## V

Voltage group, 2-12