

# SINAMICS G120

Power Module PM260

Hardware Installation Manual · 08/2013

**SINAMICS**

Answers for industry.

**SIEMENS**



# SIEMENS

## SINAMICS

### SINAMICS G120 Power Module PM260

#### Hardware Installation Manual

<u>Introduction</u>	<b>1</b>
<u>Safety notes</u>	<b>2</b>
<u>Description</u>	<b>3</b>
<u>Installing/Mounting</u>	<b>4</b>
<u>Technical specifications</u>	<b>5</b>
<u>Dimensional drawings</u>	<b>6</b>
<u>Spare parts/Accessories</u>	<b>7</b>
<u>Appendix</u>	<b>A</b>
<u>List of abbreviations</u>	<b>B</b>

Edition 08/2013



08/2013

A5E01171966B AD

## Legal information

### Warning notice system

This manual contains notices you have to observe in order to ensure your personal safety, as well as to prevent damage to property. The notices referring to your personal safety are highlighted in the manual by a safety alert symbol, notices referring only to property damage have no safety alert symbol. These notices shown below are graded according to the degree of danger.

 <b>DANGER</b>
indicates that death or severe personal injury <b>will</b> result if proper precautions are not taken.
 <b>WARNING</b>
indicates that death or severe personal injury <b>may</b> result if proper precautions are not taken.
 <b>CAUTION</b>
indicates that minor personal injury can result if proper precautions are not taken.
<b>NOTICE</b>
indicates that property damage can result if proper precautions are not taken.

If more than one degree of danger is present, the warning notice representing the highest degree of danger will be used. A notice warning of injury to persons with a safety alert symbol may also include a warning relating to property damage.

### Qualified Personnel

The product/system described in this documentation may be operated only by **personnel qualified** for the specific task in accordance with the relevant documentation, in particular its warning notices and safety instructions. Qualified personnel are those who, based on their training and experience, are capable of identifying risks and avoiding potential hazards when working with these products/systems.

### Proper use of Siemens products

Note the following:

 <b>WARNING</b>
Siemens products may only be used for the applications described in the catalog and in the relevant technical documentation. If products and components from other manufacturers are used, these must be recommended or approved by Siemens. Proper transport, storage, installation, assembly, commissioning, operation and maintenance are required to ensure that the products operate safely and without any problems. The permissible ambient conditions must be complied with. The information in the relevant documentation must be observed.

### Trademarks

All names identified by ® are registered trademarks of Siemens AG. The remaining trademarks in this publication may be trademarks whose use by third parties for their own purposes could violate the rights of the owner.

### Disclaimer of Liability

We have reviewed the contents of this publication to ensure consistency with the hardware and software described. Since variance cannot be precluded entirely, we cannot guarantee full consistency. However, the information in this publication is reviewed regularly and any necessary corrections are included in subsequent editions.

# Table of contents

<b>1</b>	<b>Introduction</b> .....	<b>7</b>
<b>2</b>	<b>Safety notes</b> .....	<b>9</b>
<b>3</b>	<b>Description</b> .....	<b>17</b>
3.1	Power module PM260.....	18
3.2	Block diagram .....	19
<b>4</b>	<b>Installing/Mounting</b> .....	<b>21</b>
4.1	Mechanical Installation.....	21
4.2	Electrical Installation .....	24
4.2.1	Power and motor connections .....	29
4.2.2	Motor circuit.....	33
<b>5</b>	<b>Technical specifications</b> .....	<b>35</b>
<b>6</b>	<b>Dimensional drawings</b> .....	<b>41</b>
<b>7</b>	<b>Spare parts/Accessories</b> .....	<b>43</b>
<b>A</b>	<b>Appendix</b> .....	<b>47</b>
A.1	Electromagnetic Compatibility.....	47
A.2	Definition of the EMC Environment and Categories .....	47
A.3	Standards .....	49
<b>B</b>	<b>List of abbreviations</b> .....	<b>51</b>
	<b>Index</b> .....	<b>53</b>



# Introduction

## Available technical documentation

Comprehensive information and support tools are available from the Service and Support internet site

- <http://support.automation.siemens.com>

You find there the following types of documentation:

- Getting Started
- Operating Instructions
- Hardware Installation Manual
- Function Manual
- Parameter Manual
- Product Information

## Further internet addresses

You can download the respective documents for your inverter under the following links:

- SINAMICS G110  
<http://www.siemens.com/sinamics-g110>
- SINAMICS G120  
<http://www.siemens.com/sinamics-g120>
- SINAMICS G120D  
<http://www.siemens.com/sinamics-g120d>
- SIMATIC ET 200S FC  
<http://www.siemens.com/et200s-fc>
- SIMATIC ET 200pro FC  
<http://www.siemens.com/et200pro-fc>

## Application examples

You find various application examples to the inverters under the following link:

- <http://support.automation.siemens.com/WWW/view/en/20208582/136000>





## Safety notes

### Safety Instructions

The following Warnings, Cautions and Notes are provided for your safety and as a means of preventing damage to the product or components in the connected machines. This section lists Warnings, Cautions and Notes, which apply generally when handling the inverter, classified as General, Transport and Storage, Commissioning, Operation, Repair and Dismantling and Disposal.

Specific Warnings, Cautions and Notes that apply to particular activities are listed at the beginning of the relevant sections in this manual and are repeated or supplemented at critical points throughout these sections.

Please read the information carefully, since it is provided for your personal safety and will also help prolong the service life of your inverter and the equipment to which it is connected.

It has to be ensured by the machine manufacturer, that the line-side overcurrent protection equipment interrupts within 5 s (immovable equipment and modules in immovable equipment) in the case of minimum fault current (current on complete insulation failure to accessible conductive parts that are not live during operation and maximum current loop resistance).

### General

#### WARNING

This equipment controls potentially dangerous rotating mechanical parts.

Protection in case of direct contact by means of voltages < 60V (PELV = Protective Extra Low Voltage acc. to EN 61800-5-1) is only permissible in areas with equipotential bonding and in dry indoor rooms. If these conditions are not fulfilled, other protective measures against electric shock are to be taken, e.g., protective insulation.

The converter must always be properly grounded. Since the residual current for this product is greater than 3.5mA AC, a fixed ground connection is required, and the minimum size of the protective conductor must comply with local safety regulations for equipment with a high leakage current.

Install the converter on a metal mounting plate in a control cabinet. The mounting plate must not be painted and must have good electrical conductivity.

It is strictly prohibited for any mains disconnection to be performed on the motor-side of the system, if the converter is in operation and the output current is not equal to zero.

Take particular notice of the general and regional installation and safety regulations regarding work on dangerous voltage installations (e.g. 61800-5-1) as well as the relevant regulations regarding the correct use of tools and personal protective equipment (PPE).

 **CAUTION**

Static discharges on surfaces or interfaces (e.g. terminal or connector pins) can cause malfunctions or defects. ESD protective measures should therefore be observed when working with converters or converter components.

## Transport and storage

 **CAUTION**

Don't drop the converter or converter components during transport and storage. Protect the equipment from water (rainfall) and excessive temperatures.

## Commissioning

 **WARNING**

Working on the equipment by unqualified personnel or failure to comply with warnings can result in severe personal injury or serious damage to material. Only suitably qualified personnel trained in the setup, installation, commissioning and operation of the product should carry out work on the equipment.

 **CAUTION**

**Cable connection**

The control cables must be laid separately from the power cables. Carry out the connections as shown in the installation section in this manual, to prevent inductive and capacitive interference from affecting the correct function of the system.

## Mechanical Installation

 **WARNING**

To ensure the safe operation of the equipment, it must be installed and commissioned by qualified personnel in full compliance with the warnings laid down in this manual.

Take particular note of the general and regional installation and safety regulations regarding work on dangerous voltage installation (e.g. EN 61800-5-1) as well as the relevant regulations regarding the correct use of tools and personal protective equipment (PPE).

** WARNING****Power and motor connections**

The inverter must be grounded from the supply side and the motor side. If it is not grounded correctly, extremely dangerous conditions may arise which could prove potentially fatal.

Isolate the mains electrical supply before making or changing connections to the unit.

Ensure that the appropriate circuit-breakers/fuses with the specified current rating are connected between the power supply and the inverter.

The terminals of the Inverter can carry dangerous voltages even if the inverter is inoperative. Wait at least 5 minutes to allow the unit to discharge after switching off the line supply before carrying out any installation work.

When connecting the line supply to the inverter, make sure that the terminal case of the motor is closed.

When changing from the ON to OFF-state of an operation if an LED or other similar display is not lit or active; this does not indicate that the unit is switched-off or powered-down.

Ensure that the inverter is configured for the correct supply voltage – it must not be connected to a higher voltage supply.

## Installation and Commissioning

** WARNING**

Wherever faults occurring in the control equipment can lead to substantial material damage or even grievous bodily injury (that is, potentially dangerous faults), additional external precautions must be taken or facilities provided to ensure or enforce safe operation, even when a fault occurs (e.g. independent limit switches, mechanical interlocks, etc.).

## Operation

** DANGER**

Operating the converter outside the scope of the specification given in the technical specifications may cause malfunction or damage to the converter components. In exceptional cases there is the potential to cause overheating, danger of fire, damage to property, personal injury or loss of life.

 **WARNING**

Emergency stop facilities according to EN 60204, IEC 204 (VDE 0113) must remain operative in all operating modes of the control equipment. Any disengagement of the emergency stop facility must not lead to an uncontrolled or an undefined restart of the equipment.

 **WARNING**

Use of mobile radio devices (e.g. telephones, walkie-talkies) in the immediate vicinity of the devices (< 1.8 m) can interfere with the functioning of the equipment.

 **WARNING**

Filtered drives can only be used on power systems with grounded neutral point.

 **WARNING**

During operation and for a short time after switching-off the converter, the surfaces of the converter can reach a high temperature. Avoid coming into direct contact with the converter surface.

## High temperature



 **CAUTION**

The temperature of the surface of the power module and of the operator panel can be higher than 60 °C during operation and after power off.

## Repair

 **WARNING**

Repairs on equipment may only be carried out by Siemens Service, by repair centers authorized by Siemens or by authorized personnel who are thoroughly acquainted with all the warnings and operating procedures contained in this manual.

Any defective parts or components must be replaced using parts contained in the relevant spare parts list.

## Dismantling and disposal

NOTICE
<p>The packaging of the inverter is re-usable. Retain the packaging for future use.</p> <p>Easy-to-release screw and snap connectors allow you to break the unit down into its component parts. You can recycle these component parts, dispose of them in accordance with local requirements or return them to the manufacturer.</p>

## Residual risks of power drive systems

The control and drive components of a drive system are approved for industrial and commercial use in industrial line supplies. Their use in public line supplies requires a different configuration and/or additional measures.

These components may only be operated in closed housings or in higher-level control cabinets with protective covers that are closed, and when all of the protective devices are used.

These components may only be handled by qualified and trained technical personnel who are knowledgeable and observe all of the safety instructions on the components and in the associated technical user documentation.

When assessing the machine's risk in accordance with the respective local regulations (e.g., EC Machinery Directive), the machine manufacturer must take into account the following residual risks emanating from the control and drive components of a drive system:

1. Unintentional movements of driven machine components during commissioning, operation, maintenance, and repairs caused by, for example:
  - Hardware defects and/or software errors in the sensors, controllers, actuators, and connection technology
  - Response times of the controller and drive
  - Operating and/or ambient conditions outside of the specification
  - Condensation / conductive contamination
  - Parameterization, programming, cabling, and installation errors
  - Use of radio devices / cellular phones in the immediate vicinity of the controller
  - External influences / damage
2. In the event of a fault, exceptionally high temperatures, including an open fire, as well as emissions of light, noise, particles, gases, etc. can occur inside and outside the inverter, e.g.:
  - Component malfunctions
  - Software errors
  - Operating and/or ambient conditions outside of the specification
  - External influences / damage

Inverters of the Open Type / IP20 degree of protection must be installed in a metal control cabinet (or protected by another equivalent measure) such that the contact with fire inside and outside the inverter is not possible.
3. Hazardous shock voltages caused by, for example:
  - Component malfunctions
  - Influence of electrostatic charging
  - Induction of voltages in moving motors
  - Operating and/or ambient conditions outside of the specification
  - Condensation / conductive contamination
  - External influences / damage
4. Electrical, magnetic and electromagnetic fields generated in operation that can pose a risk to people with a pacemaker, implants or metal replacement joints, etc. if they are too close.
5. Release of environmental pollutants or emissions as a result of improper operation of the system and/or failure to dispose of components safely and correctly.

---

**Note**

The components must be protected against conductive contamination (e.g. by installing them in a control cabinet with degree of protection IP54 according to IEC 60529 or NEMA 12).

Assuming that conductive contamination at the installation site can definitely be excluded, a lower degree of cabinet protection may be permitted.

---

For more information about residual risks of the components in a drive system, see the relevant sections in the technical user documentation.





## Description

### The SINAMICS G120 range

The SINAMICS G120 inverter has been designed for the accurate and efficient control of the speed and torque for three-phase motors. The SINAMICS G120 system comprises two basic modules, the Control Unit (CU) and the Power Module (PM).

The Control Units are divided into the following:

- CU without fail-safe functions
  - CU230P-2 HVAC for pump and fan applications with Modbus RTU interface
  - CU230P-2 CAN for pump and fan applications with CANopen interface
  - CU230P-2 DP for pump and fan applications with PROFIBUS DP interface
  - CU240E economic version of the CU240 Control Units (e.g. less terminals, no encoder interface)
  - CU240S standard version of the CU240 Control Units
  - CU240S DP like CU240S plus PROFIBUS DP interface (PROFIdrive Profile V4.1)
  - CU240S PN like CU240S plus PROFINET interface (PROFIdrive Profile V4.1)
- CU with fail-safe functions
  - CU240S DP-F like CU240S DP plus integrated fail-safe functions
  - CU240S PN-F like CU240S PN plus integrated fail-safe functions

The Power Modules differ concerning the supply voltage and the way of realizing the motor braking function:

- PM240 Power Module with resistor braking and dc braking functions, supply voltage 3 AC 400 V
- PM250 Power Module with regenerative braking function, supply voltage 3 AC 400 V
- PM260 Power Module with regenerative braking function, supply voltage 3 AC 690 V

Control Units and Power Modules are allowed to be combined in any possible configuration.

Exceptions:

The CU230P-2 with firmware V4.2 can not be combined with PM240 FSGX or PM260. These combinations will be allowed with firmware V4.3.

See the respective manual for specific functions and features.

## 3.1 Power module PM260

### Overview

The power modules contain an integrated sine wave output filter for sinusoidal output voltage. They are available with protection level IP20 according to EN 60529, with or without integrated Class A filter in the following frame sizes and power ranges:

- Frame size D, 7,5 kW ... 15 kW
- Frame size F, 22 kW ... 37 kW

The power modules have regenerative capability, where the regeneration limit is the maximum nominal power (high overload) of the power module.

The PM260 power modules can be used together with G120 standard control units or with G120 fail-safe control units.

 <b>CAUTION</b>
--

The PM260 power modules can be used for three phase asynchronous motors, synchronous motors are not allowed.
--

## 3.2 Block diagram

### Block diagram

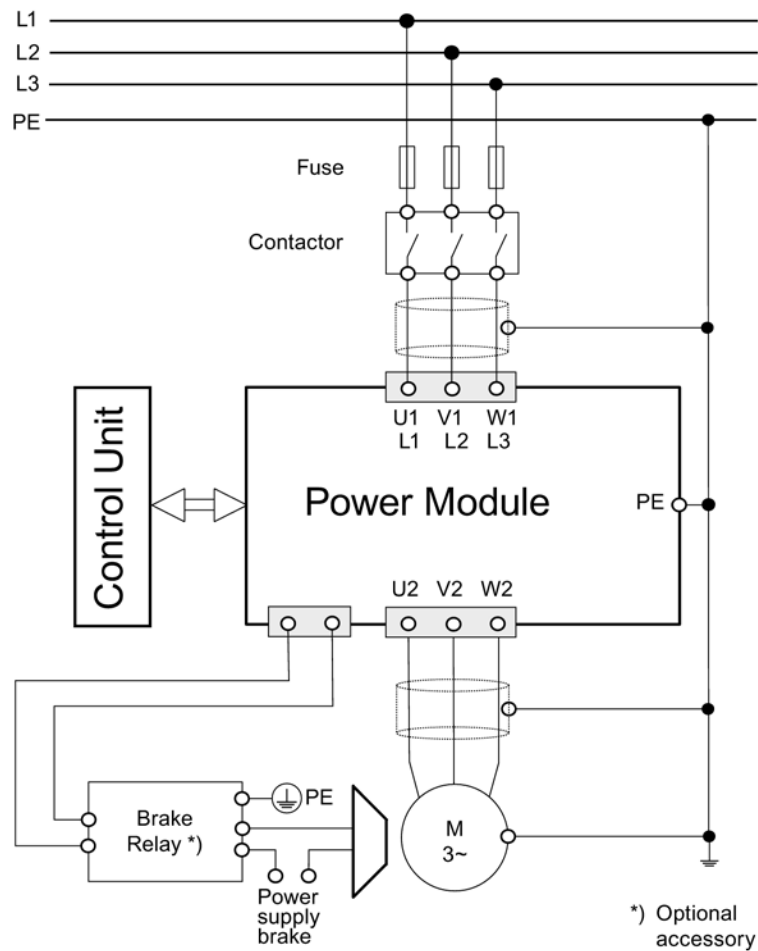

Figure 3-1 Power Module PM260

*Description*

---

*3.2 Block diagram*

## Installing/Mounting

### General rules for the environmental protection of the Power Modules

To ensure that the power module is installed in the correct environmental conditions, please ensure that you adhere to the following guidelines:

- The Power Module FSA ... FSF is designed for IP20 protection. It is protected from the ingress of solid foreign objects  $\geq 12.5$  mm ( $\geq 0.49$  inches)
- The Power Module FSGX is designed for IP20 or IPXXB protection. It is protected from the ingress of solid foreign objects  $\geq 12.5$  mm ( $\geq 0.49$  inches) respectively from accessing dangerous parts with a finger
- The Power Module is not protected against the ingress of water
- The Power Module is designed to be installed in an electrical cabinet
- Keep the Power Module free from dust and dirt
- Keep the Power Module away from water, solvents and chemicals  
Take care to site the inverter away from potential water hazards, for example, do not install the inverter beneath pipes that are subject to condensation. Avoid installing the inverter where excessive humidity and condensation may occur
- Keep the Power Module within the maximum and minimum operating temperatures
- Ensure that the correct level of ventilation and air flow is provided
- Ensure that earthing and grounding practices for each Power Module and the cabinet follows the guidelines given in this document

 <b>CAUTION</b>
--

The SINAMICS G120 Power Module <b>MUST NOT</b> be mounted horizontally.
---

### 4.1 Mechanical Installation

 <b>WARNING</b>
--

To ensure the safe operation of the equipment, it must be installed and commissioned by qualified personnel in full compliance with the warnings laid down in this manual.
--

Take particular note of the general and regional installation and safety regulations regarding work on dangerous voltage installation (e.g. EN 61800-5-1) as well as the relevant regulations regarding the correct use of tools and personal protective equipment (PPE).
---

### Installation and cooling

Make sure that there is an adequate airflow through the cubicle as follows:

1. Add the air flow values required for every Power Module (see following table) within the cubicle
2. Calculate the airflow required by components as reactor, filter, Control Unit and other electronic devices using the formula  
$$\text{Air flow (l/s)} = (\text{Power loss (Watt)} / \Delta T) \times 0.86$$

( $\Delta T$  = Allowable temperature rise within the cubicle in °C).  
For the power losses of components see the following table
3. Add the airflow values of all components within the cubicle to get the complete air flow required
4. No equipment should be installed that could have a negative effect on the flow of cooling air
5. Make sure that the cooling vents in the Power Module are positioned correctly to allow the free movement of air
6. Avoid cooling air short circuit using air barriers, if necessary

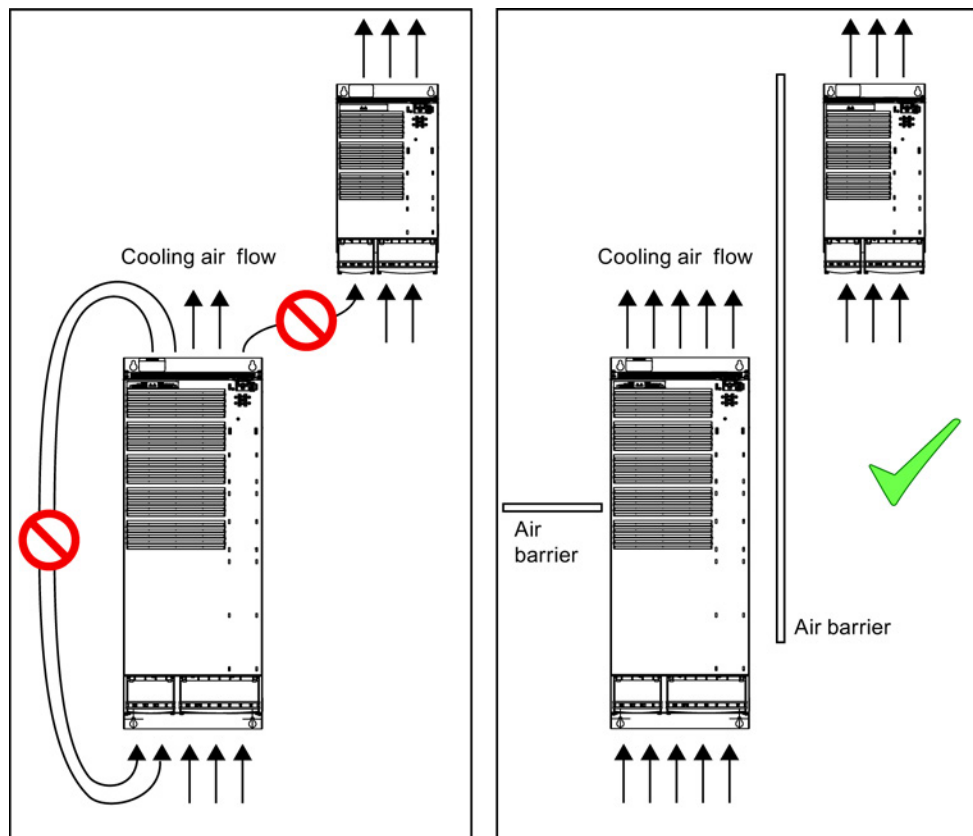

Figure 4-1 Air barriers for avoiding cooling air short circuits

7. Provide an adequate cubicle with sufficient air vent and suitable air strainer

### Distances to other equipment

The power modules can be mounted without any clearance at either side. When mounting one above the other, the specified environmental conditions must not be exceeded. Independent of this, the following distances above and below must be observed:

- Frame Size D: above and below 300 mm (11.81 inches)
- Frame Size F: above and below 350 mm (13.77 inches).

### Dimensions and drill pattern for power modules

To allow the preliminary installation work to be undertaken, dimensions and drill patterns for the power modules are shown below.

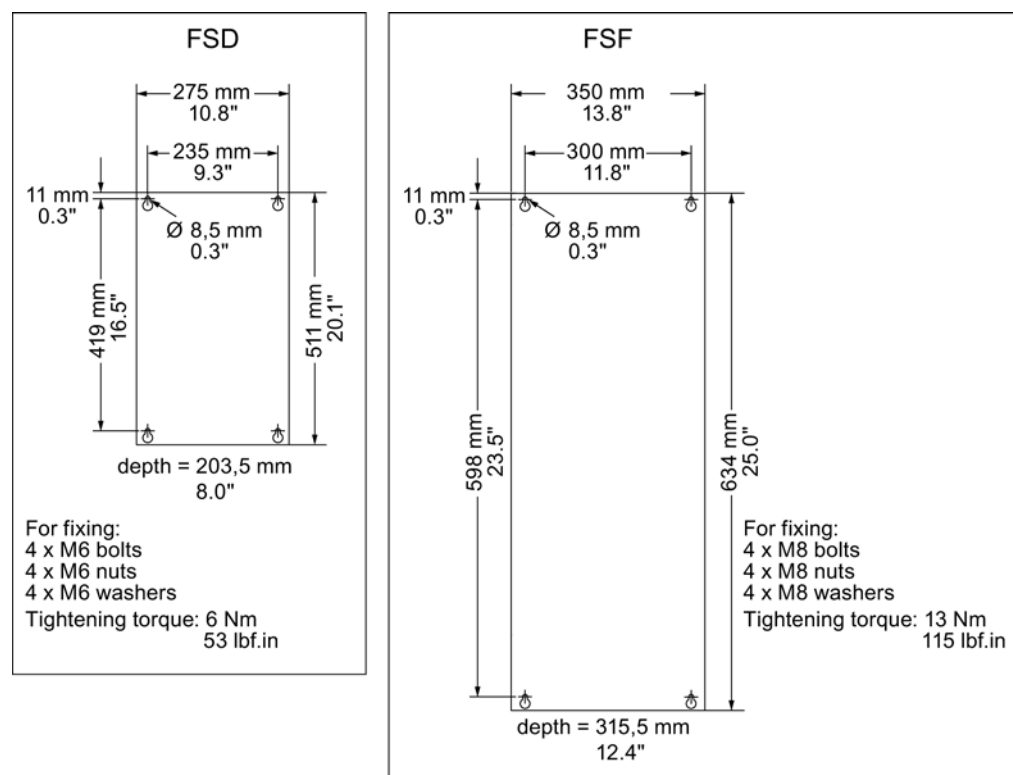

Figure 4-2 Dimensions and drill pattern for the power modules

### Fitting the Control Unit to the Power Module

The Control Unit is snapped onto the Power Module as shown in the figure below. To disconnect the CU push the release button on top of the PM.

The process of fitting the Control Unit to the Power Module is the same technique independent from the type of G120 control unit or G120 power module.

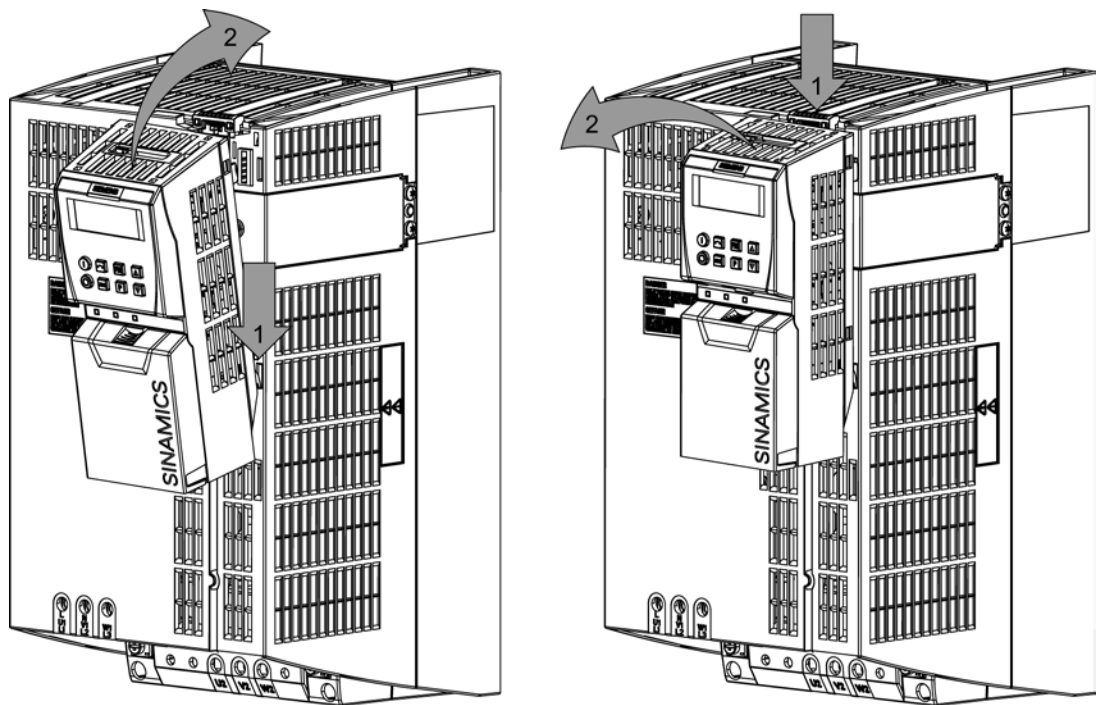

Figure 4-3 Fitting the control unit to the power module

## 4.2 Electrical Installation

### Overview

This section gives information about

- power distribution systems,
- connecting the motor,



- screening methods
- motor connection star/delta

 **WARNING**

**Power and motor connections**

- The inverter must be grounded from the supply side and the motor side. If the inverter is not grounded correctly, extremely dangerous conditions may arise which could prove potentially fatal.
- Isolate the mains electrical supply before making or changing connections to the unit.
- The terminals of the Inverter can carry dangerous voltages even if the inverter is inoperative. Wait at least 5 minutes to allow the unit to discharge after switching off the line supply before carrying out any installation work.
- When connecting the line supply to the inverter, make sure that the terminal case of the motor is closed.
- When changing from the ON to OFF-state of an operation if an LED or other similar display is not lit or active; this does not indicate that the unit is switched-off or powered-down. Input chokes must not be used.
- RSCE of the power supply must be at least 100.
- Ensure that the inverter is configured for the correct supply voltage – the inverter must not be connected to a higher voltage supply.
- If a residual-current device is used on the supply side of this electronic equipment for protection in case of direct or indirect contact, only Type B is permitted! Otherwise a different protective measure must be employed, such as separation of the electronic equipment from the environment by double or reinforced insulation, or from the supply by a transformer!"

 **CAUTION**

The control cables must be laid separately from the power cables. The connection must be carried out as shown in the installation section in this manual, to prevent inductive and capacitive interference from affecting the correct function of the system.

**Note**

Ensure that the appropriate circuit-breakers/fuses with the specified current rating (see technical data) are connected between the power supply and the inverter.

### Overview of Power Distribution Systems

The power distribution systems described below, as defined in EN 60950, have been considered in the design of the inverter. In the next figures three phase systems are outlined. The three phase inverter must be connected to L1, L2 and L3. PE must always be connected. The inverter will operate with most supply systems.

Table 4- 1 Power distribution systems

TN-S Power System	TN-C-S Power System	TN-C Power System	TT Power System	IT Power System
<p>A TN-S power system has separate neutral and protective ground conductors throughout the system.</p>	<p>In a TN-C-S power system, the neutral and protective functions are combined in a single part of the system.</p>	<p>In a TN-C power system, the neutral and protective functions are combined in a single conductor throughout the system.</p>	<p>A TT power system has one point directly grounded, the exposed conductive parts of the installation being connected to a ground, which is electrically independent of the ground of the power system.</p>	<p>An IT power system has no direct connection to ground - instead the exposed parts of the electrical installation are grounded.</p>

	<p><b>WARNING</b></p>
<p>Filtered drives can only be used on power systems with grounded starpoint.</p>	

**Note**

For fulfilling the protection class I according to EN 61140 the input and output supply voltages have to be earthed.

### Permissible Cable Length

The use of unshielded motor cables is possible. However to meet C2 EMI class, shielded cables with appropriate EMI installation are required.

Table 4- 2 The inverters will operate at full specification with cable lengths as follows

- Screened 200 m (656 ft)
- Unscreened 300 m (984 ft)

Table 4- 3 Cable cross section

Frame size kW	Cable cross section		Tightening torques	
	mm <sup>2</sup>	AWG	Nm	lbf in
<b>FSD</b>				
7.5:	2,5 ... 16	14 ... 6	1.5	14
11:	4 ... 16	12 ... 6	1.5	14
15:	6 ... 16	10 ... 6	1.5	14
<b>FSF</b>				
22:	10 ... 35	8 ... 2	6	53
30:	16 ... 35	6 ... 2	6	53
37:	25 ... 35	4 ... 2	6	53

 **CAUTION**

The cable cross section for grounding must be the same as the motor cables but at least 10 mm<sup>2</sup> (Cu) or 16 mm<sup>2</sup> (Al).

### Access to power and motor terminals

Frame size D has terminal blocks for power and motor connection. The terminal blocks can be removed after releasing 2 fixing screws. Thus a power module can be exchanged easily by removing the terminal blocks from the old one and plugging it onto the new one without new cabling. Once the change has been performed, the fixing screws of the terminal block must be tightened again.

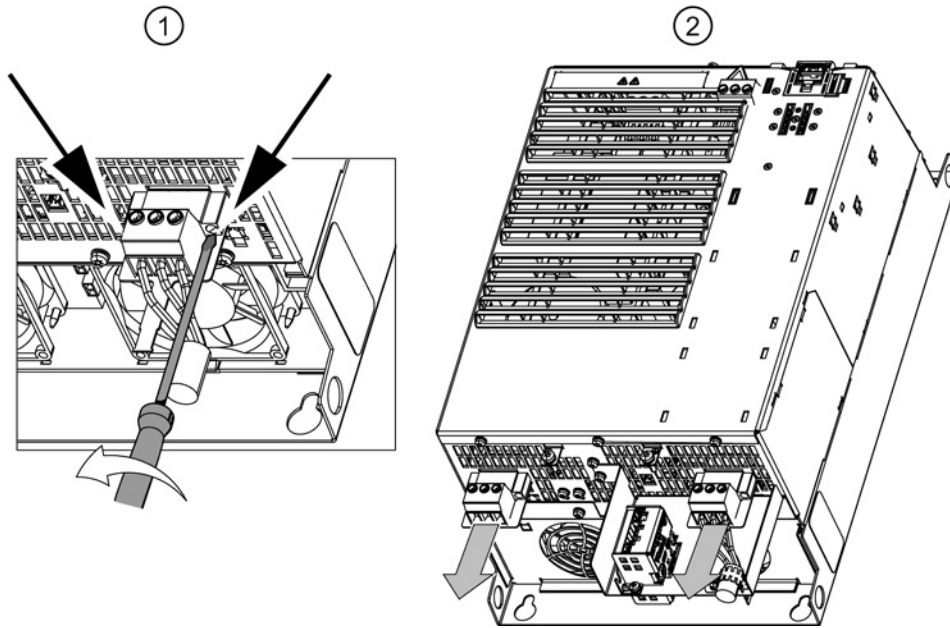

Figure 4-4 Power terminals Frame Size D

Frame sizes F terminals can be accessed by releasing the latches on the left and right side of the terminal covers with a suitable flat-bladed screw driver. The cover then can be turned upwards so that the terminals can be accessed. After connecting the cables the covers must be locked again.

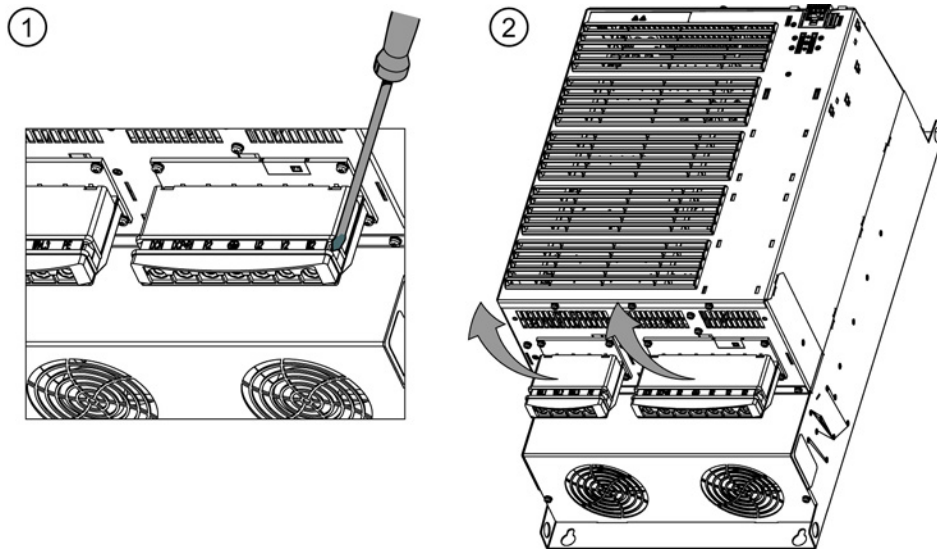

Figure 4-5 Power terminals Frame Size F

#### 4.2.1 Power and motor connections

##### Power and motor terminal layout

The figures below shows the layout of the power and motor terminals of the PM260 Frame Sizes D and F.

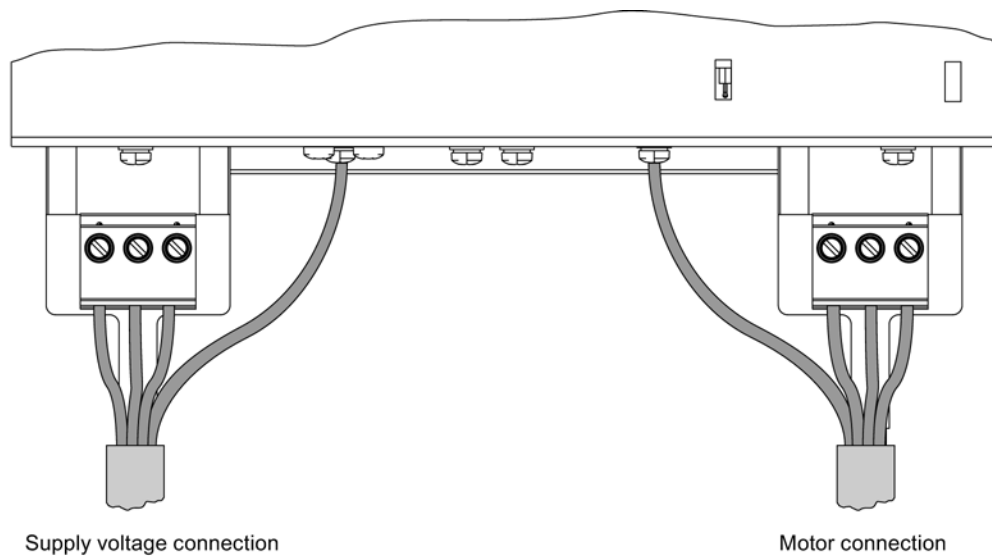

Figure 4-6 Power Connection PM260 FSD

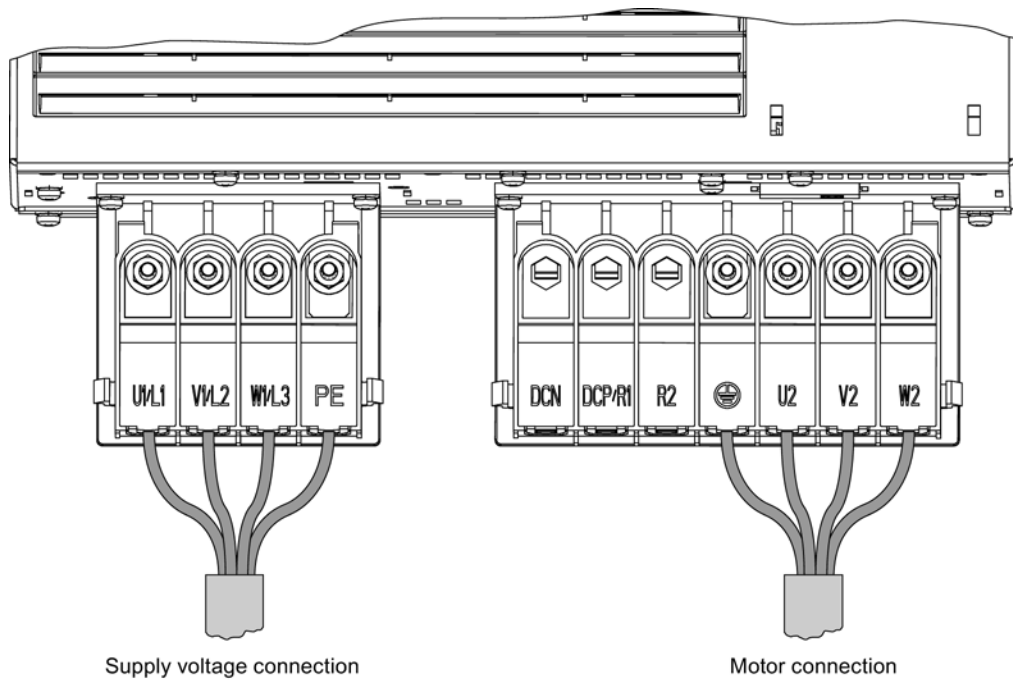

Figure 4-7 Power Connection PM260 FSF

### Avoiding Electromagnetic Interference (EMI)

The inverters are designed to operate in an industrial environment where a high level of EMI can be expected. Most installations do not give problems. However, it is good engineering practice to conform to the following guidelines - this will reduce the likelihood of problems during operation.

#### Actions to take

- Ensure that all equipment in the cubicle is well grounded using short, thick grounding cable connected to a common star point or busbar.
- Make sure that any control equipment (such as a PLC) connected to the inverter is connected to the same ground or star point as the inverter using a short thick link.
- Connect the return ground from the motors directly to the ground connection (PE) on the associated inverter.
- Flat conductors are preferred as they have lower impedance at higher frequencies.
- Terminate the ends of the cable neatly, ensuring that unscreened wires are as short as possible.
- Separate the control cables from the power cables as much as possible, using separate trunking, if the cables cross they should cross at 90° to each other.
- Whenever possible, use screened leads for the connections to the control circuitry.

- Ensure that the contactors in the cubicle are suppressed, either with R-C suppressors for AC contactors or 'flywheel' diodes for DC contactors fitted to the coils. Varistor suppressors are also effective. This is important when the contactors are controlled from the inverter relay.
- Use screened or armored cables for the motor connections and ground the screen at both ends using the cable clamps.

 <b>WARNING</b>
--

Safety regulations must not be compromised when installing inverters!
---

### Screening methods

For all frame sizes the Screen Termination Kit is supplied as an optional extra. It allows easy and efficient connection of the necessary screening. For further details on the Screen Termination Kit, please refer to the SINAMICS G120 catalog.

### Screening without a Screen Termination Kit

In order to meet radiated emissions a screen termination kit must be used. Screening without a screen termination kit is only suitable for installation in a metal cabinet.

Should a Screen Termination Kit not be available, the inverter then can be screened using the methodology shown in the figure below. This diagram shows both methodologies of screening.

---

#### **Note**

The EMI illustration below is not to scale.

---

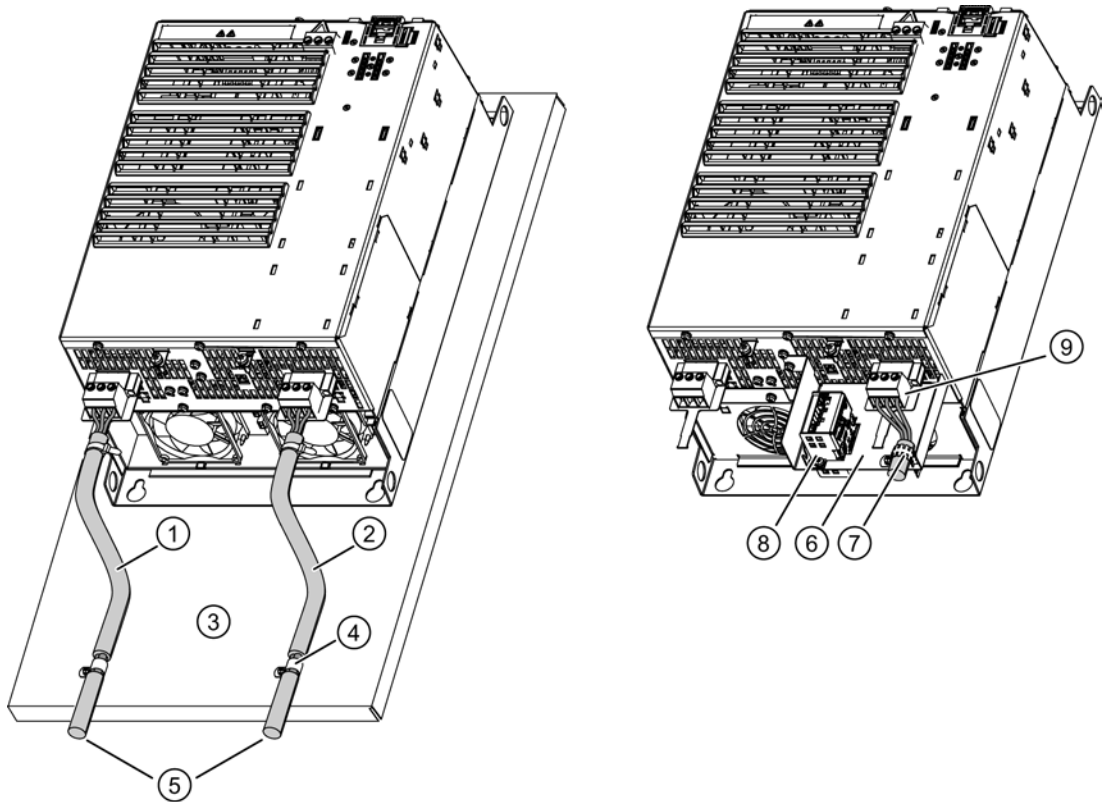

Figure 4-8 Example of wiring to minimize the effect of EMI

Table 4-4 Legend to the drawing

1	Line power input	5	Screened cables
2	Motor cable	6	Screen termination kit
3	Metal back plate	7	Cable clamp
4	Use suitable clips to fix motor and power cable screen securely to metal back plate	8	Brake Relay
		9	Terminal blocks



## 4.2.2 Motor circuit

### Motor Circuit

In order to ensure a straightforward, successful commissioning, it is important that the circuit connection in the motor terminal box matches the rated motor voltage entered in P0304 or the rated motor current P0305.

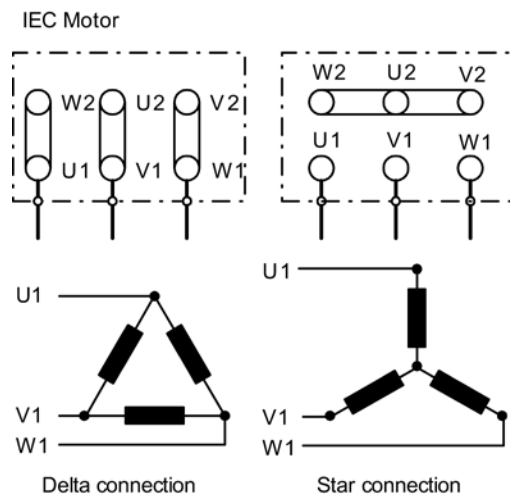

Figure 4-9 Motor connection - IEC motors 400 V delta connection, 690 V Star connection

#### Note

690 V / 400 V Standard motors must always be connected in star configuration.

The following must be noted when entering the rating plate data or the ECD data:

- The outer conductor voltage/phase-to-phase voltage (voltage U12 between outer conductors L1, L2) and the outer conductor current (phase current) I1 are always specified on the rating plate.
- The rated motor voltage and the rated motor current must always be entered according to the motor circuit configuration (either delta/star circuit configuration).

- If rated motor data that are available are not consistent with the motor circuit configuration, then an appropriate conversion should be made which is then entered.
- If equivalent circuit diagram data is available, then these should be entered according to the motor circuit configuration. If there is no consistency between the motor circuit configuration and equivalent circuit diagram data, then the equivalent circuit diagram data should be converted and entered corresponding to the data on the rating plate.

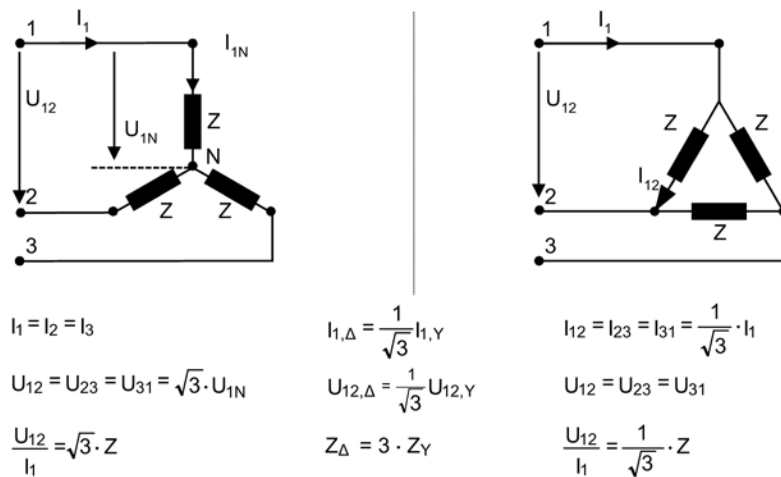

Figure 4-10 Star/Delta configuration

**Note**

The precise equivalent circuit diagram data is of extreme importance regarding the stability of the closed-loop vector control and for the voltage boost applied to the V/f characteristic. Equivalent circuit diagram data can only be estimated from the rating plate data; this is the reason that equivalent circuit diagram data is either determined

- using the motor data identification, or
- is entered from a motor data sheet that may be available.

## Technical specifications

### SINAMICS G120 Power Module

Table 5- 1 Performance ratings

Feature	Specification
Line operating voltage & power ranges	3 AC 660 V ... 690 V $\pm$ 10%
	The power modules can be operated with a minimum voltage of 450 V. In this case the output voltage will be reduced accordingly.
	High Overload: 7.5 kW ... 37 kW (10 hp ... 50.0 hp) Light Overload: 11 kW ... 55 kW (15.0 hp ... 74.0 hp)
Input frequency	47 Hz ... 63 Hz
Output frequency	0 Hz ... 200 Hz
Power factor $\lambda$	0.9
Inverter efficiency	95% ... 97%
Overload capability (HO)	1.5 x Nominal output current (150% overload) for 57 s every 300 s
	2 x Nominal output current (200% overload) for 3 s every 300 s
Overload capability (LO)	1.1 x Nominal output current (110% overload) for 57 s every 300 s
	1.4 x Nominal output current (140% overload) for 3 s every 300 s
Inrush current	Less than rated input current
Pulse frequency	16 kHz
Electromagnetic compatibility	Integrated Class A filters for filtered units
Braking	Regeneration (up to 100% high overload output rating)
Protection level	IP20
Temperature range without derating (HO)	0° C ... +50° C
Temperature range without derating (LO)	0° C ... +40° C
Temperature range with derating	Operational temperature up to 60° C (140° F) is possible with power derating
Storage temperature	-40 °C ... +70 °C (-40 °F ... 158 °F)
Humidity	< 95% RH - non-condensing
Operational altitude	Up to 1000 m (3300 ft) above sea level without derating
Protection features	Undervoltage, Overvoltage, Overload, Ground faults, Short circuit, Stall prevention, Motor blocking protection, Motor overtemperature, Power Module overtemperature, Parameter interlock
Standards	CE, C-TICK
CE marked	Conformity with EC Low Voltage Directive 2006/95/EC and filtered versions also Electromagnetic Compatibility Directive 89/336/EEC

Power Module PM260 Specifications

 <b>CAUTION</b>
<b>High Overload (HO) and Light Overload (LO) input currents</b>
The input current depends on the motor load and the line impedance. The given values apply for a load representing the rated power (based on high overload current) for a line impedance of $V_k = 1\%$ .

Table 5- 2 PM260 Frame Sizes D - 3 AC 660 V ... 690 V, ± 10% (500V - 10%)

Order No.	filtered	6SL3225-	0BH27-5AA1	0BH31-1AA1	0BH31-5AA1
	unfiltered	6SL3225-	0BH27-5UA1	0BH31-1UA1	0BH31-5UA1
Output Rating (HO)		kW	7.5	11.0	15
		hp	10.0	15.0	20.0
Output Power		kVA	14.0	19.8	24.4
Rated Input Current (LO)		A	13	18	22
HO Output Current		A	10	14	19
LO Output Current		A	14	19	23
Fuse		A	20	20	32
Required cooling air flow		l/s	22	22	39
		CFM	47	47	83
Input Cable / Output Cable		mm <sup>2</sup>	2.5 ... 16	4 ... 16	6 ... 16
		awg	14 ... 6	12 ... 6	10 ... 6
Weight	filtered	kg	23	23	23
		lb	50.7	50.7	50.7
	unfiltered	kg	21.8	21.8	21.8
		lb	48	48	48
Noise pressure		dB(A)	< 64	< 64	< 64

Table 5- 3 PM260 Frame Sizes F - 3 AC 660 V ... 690 V, ± 10% (500V - 10%)

Order No.	filtered	6SL3225-	0BH32-2AA1	0BH33-0AA1	0BH33-7AA1
	unfiltered	6SL3225-	0BH32-2UA1	0BH33-0UA1	0BH33-7UA1
Output Rating (HO)		kW	22.0	30.0	37.0
		hp	30.0	40.0	50.0
Output Power		kVA	34.3	47.3	57.2
Rated Input Current (LO)		A	34	41	60
HO Output Current		A	26	35	42
LO Output Current		A	35	42	62
Fuse		A	50	50	80

Required cooling air flow		l/s	94	94	117
		CFM	199	199	248
Input Cable / Output Cable		mm <sup>2</sup>	10 ... 35	16 ... 35	25 ... 35
		awg	8 ... 2	6 ... 2	4 ... 2
Weight	filtered	kg	58	58	58
		lb	128	128	128
	unfiltered	kg	56	56	56
		lb	123	123	123
Noise pressure		dB(A)	< 70	< 70	< 70

### Operating temperature derating

The operating temperature range is shown diagrammatically in the figure below:

Power Module FSD and FSF

Permissible high overload (HO)  
output current [%]

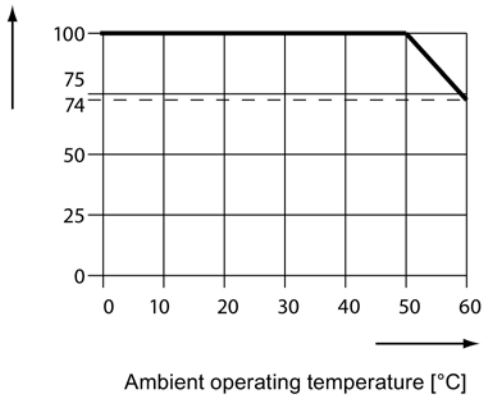

Power Module FSD

Permissible low overload (LO)  
output current [%]

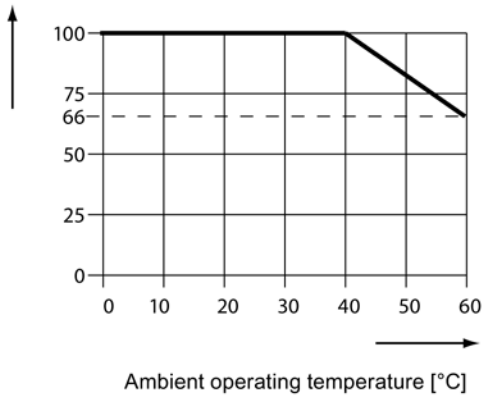

Power Module FSF

Permissible low overload (LO)  
output current [%]

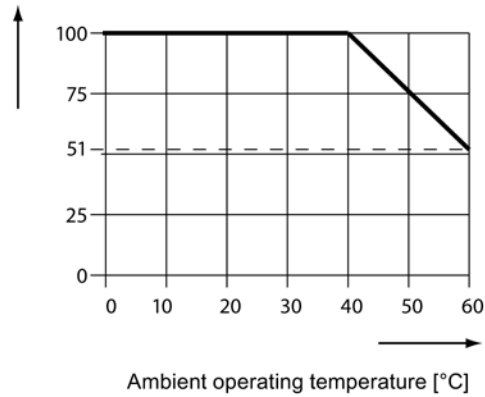

Figure 5-1 Current derating for temperature

### Operational altitude derating

The figures below show the derating required according to altitude.

Permissible (HO and LO)  
output current [%]

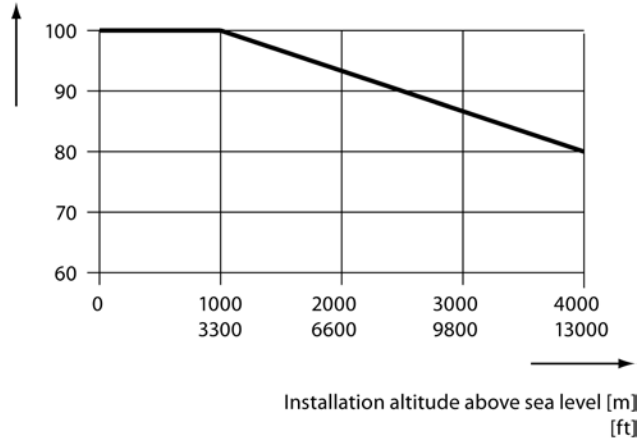

Figure 5-2 Current derating for altitude

Permissible input voltage [%]

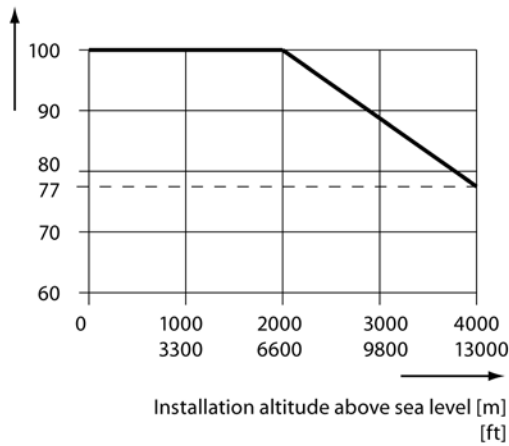

Figure 5-3 Voltage derating for altitude





## Dimensional drawings

### Power Module PM260

The dimensional drawings for the power modules PM260 are shown in the figures below.

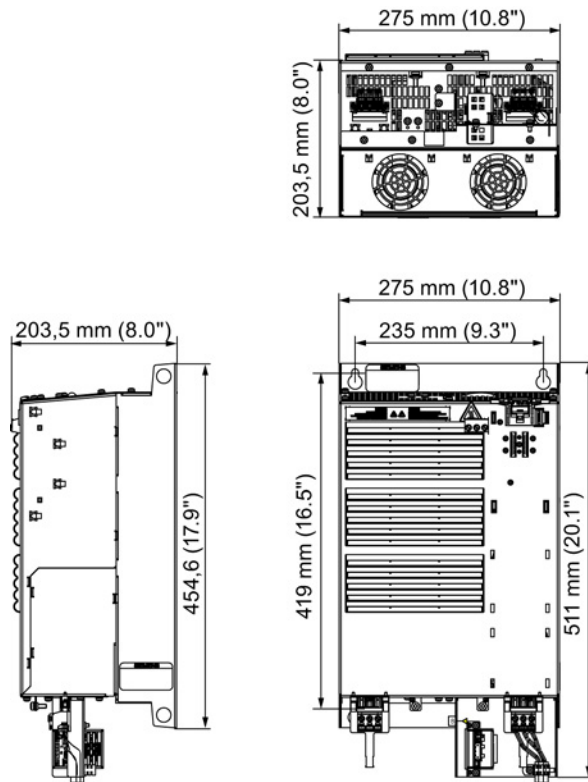

Figure 6-1 Frame size D

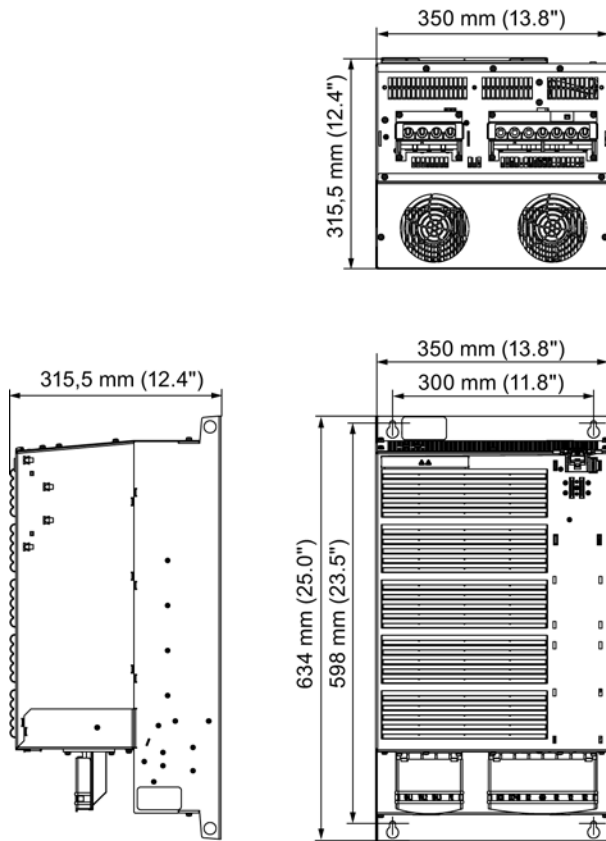

Figure 6-2 Frame size F

## Spare parts/Accessories

### Screen termination kit

The screen termination kit has been designed to allow the termination of control, mains and power cables to ensure the correct electrical grounding to the inverter.

### Brake relay

The Brake Relays is designed to provide the interface between the Power Module and the brake solenoid of a motor. There are two types of the Brake Relay:

- Brake Relay – this provides the basic braking control function.
- Safe Brake Relay – this provides for the braking control function within a safety integrated system. To adhere to the requirements of a safety integrated system, the Safe Brake Relay has been designed to allow a variable voltage to be given to the Safe Brake Relay to allow the system to determine if the brake relay is functioning correctly without actually activating the braking function.

The Brake Relay can be panel mounted, wall mounted or mounted on the screen termination plates and gland kits.

### Connecting the Brake Relay to the Power Module

Connect one end of the cable form to the Brake Relay.

Two cable form with different lengths are provided with the Brake Relay. Choice the adequate length of the cable depending on the frame size of the Power Module and on the mounting location of the Brake Relay.

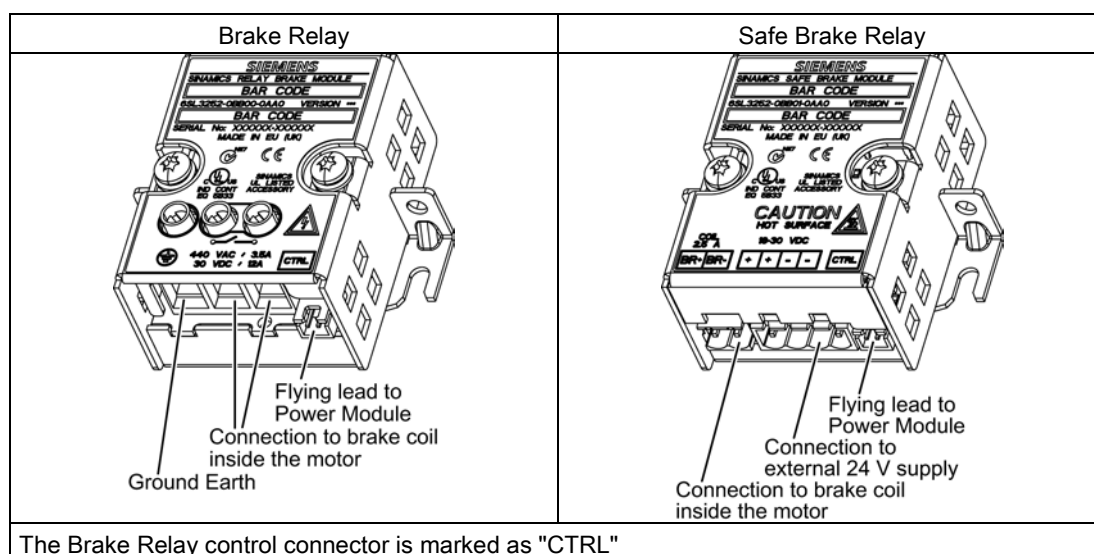

Connect the other end of the cable form to the Power Module PM260

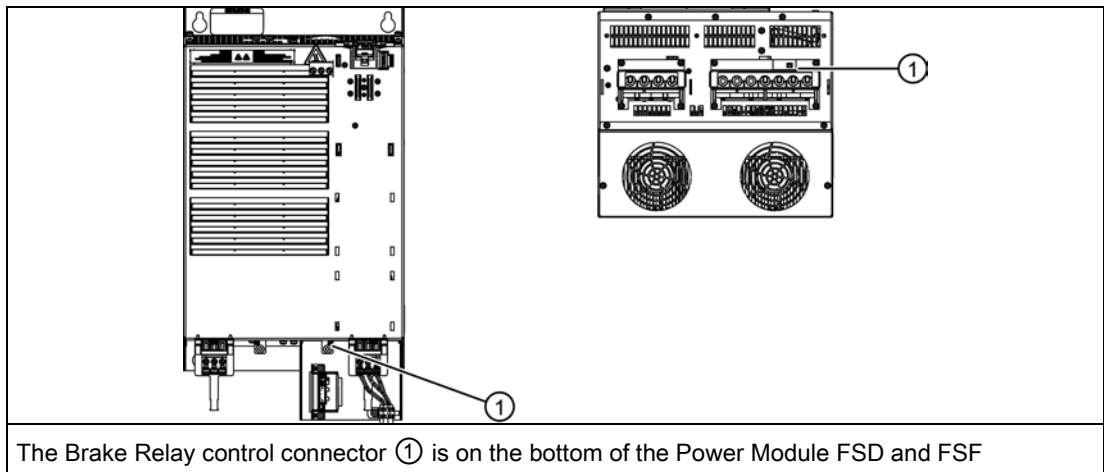

### Connecting the Brake Relay to the motor brake

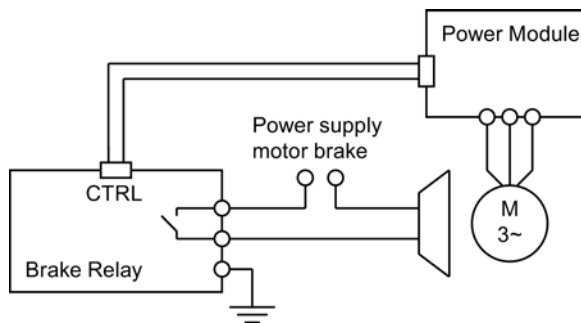

Figure 7-1 Brake Relay connection

### Connecting the Safe Brake Relay to the motor brake

The Safe Brake Relay can only control motor brakes with 24V power supply.

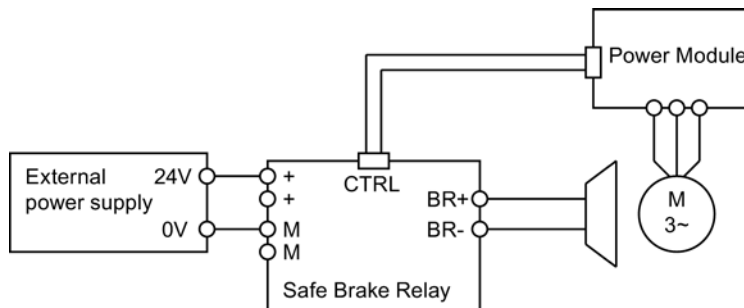

Figure 7-2 Safe Brake Relay connection

## Brake Relay specifications

	Brake Relay	Safe Brake Relay
Input voltage	connected to the internal power supply of the Power Module	DC 20.4 ... 28.8 V 1)
Input current		Max. 2.5 A
Max. conductor cross-section	2.5 mm <sup>2</sup>	2.5 mm <sup>2</sup>
Degree of protection	IP20	IP20
Switching capacity of the NO contact	1 AC 440 V, 3.5 A 1 DC 30 V DC, 12 A	-
Output voltage	-	24 V
Output current	-	max. 2 A
1) External controlled power supply is necessary. Recommended voltage: DC 26 V		

## Replacing a Cooling Fan

The power modules have been designed to allow the cooling fans to be replaced. The procedure how to replace a fan is described in the following. Furthermore an illustrated description is part of the fan package.

1. Power-down the inverter.
2. Remove the Control Unit from the inverter.
3. Disconnect all the cables from the Power Module.
4. Remove the fan cover.
5. Release the fan cable connectors.
6. Slide the cooling fan out from the inverter.
7. Fit the new cooling fan into the fan housing area (make sure that the arrow on the fan is pointing upwards) .
8. Re-attach the fan cable connector(s).
9. Replace the fan cover.
10. Reconnect all the cables to the Power Module.
11. Reattach the Control Unit.
12. Check that the installation is correct and safely installed.
13. Apply power the system.
14. Check that the cooling fan(s) are running correctly.



## Appendix

### A.1 Electromagnetic Compatibility

#### Electromagnetic compatibility

All manufacturers/assemblers of electrical apparatus which "performs a complete intrinsic function and is placed on the market as a single unit intended for the end user" must comply with the EMC directive EC/89/336.

There are three routes for the manufacturer/assembler to demonstrate compliance:

#### Self-certification

This is a manufacturer's declaration that the European standards applicable to the electrical environment for which the apparatus is intended have been met. Only standards that have been officially published in the Official Journal of the European Community can be cited in the manufacturer's declaration.

#### Technical construction file

A technical construction file can be prepared for the apparatus describing its EMC characteristics. This file must be approved by a 'Competent Body' appointed by the appropriate European government organization. This approach allows the use of standards that are still in preparation.

#### EMC Standards

The SINAMICS G120 drives have been tested in accordance with the EMC Product Standard EN 61800-3:2004.

#### Interference Resistance

The interference resistance is in accordance with the given values of the standard.

### A.2 Definition of the EMC Environment and Categories

#### Classification of EMC performance

The EMC environment and categories are defined within the EMC Product Standard EN 61800-3, as follows:

**First Environment**

An environment that includes domestic premises and establishments that are connected directly to a public low-voltage power supply network without the use of an intermediate transformer.

**Note**

For example: houses, apartments, commercial premises or offices in a residential building.

**Second Environment**

An environment that includes industrial premises and establishments that are not connected directly to a public low-voltage power supply network.

**Note**

For example: industrial and technical areas of buildings fed from a dedicated transformer.

**Category C1**

Power Drive System (PDS) of rated voltage less than 1000 V intended for use in the First (Domestic) Environment.

**Category C2**

Power Drive System (PDS) of rated voltage less than 1000 V, which is neither a plug in device nor a movable device, and when used in the First (Domestic) Environment, is only intended to be installed and commissioned by a professional.

**Note**

A professional is a person or an organization having necessary skills in installing and/or commissioning a Power Drive System (PDS), including their EMC aspects.

**Category C3**

Power Drive System (PDS) of rated voltage less than 1000 V intended for use in the Second (Industrial) Environment and not intended for use within the First (Domestic) Environment.

Table A- 1 Compliance Table

Model	Remarks
<b>Category C1 - First Environment</b>	
--	The inverters are not intended for use within the Category C1 Environment.
<b>Category C2 - First Environment - Professional Use</b>	



Model	Remarks
Filtered Variants	6SL3225-0BH**-*AA* (integrated class A filter)
	200 m screened cable type CY
	When used in the First (Domestic) Environment this product may cause radio interference in which case mitigation measures may be required. Units installed within the Category C2 (Domestic) Environment require supply authority acceptance for connection to the public low-voltage power supply network. Please contact your local supply network provider.
<b>Category C3 - Second Environment</b>	
Unfiltered Variants	6SL3225-0BH**-*UA*
	The use of unfiltered drives within an industrial installation is only possible if it forms part of a system which includes additional power-line filtering at the "system level" or, alternatively, the use of filtered variants.

#### Note

All drives should be installed and commissioned in accordance with the manufacturer's guidelines and in accordance with good EMC practices.

For further information refer to SIEMENS application note "EMC Design Guidelines".

## A.3 Standards



#### European Low Voltage Directive

The SINAMICS G120 product range complies with the requirements of the Low Voltage Directive 2006/95/EC as amended by Directive 98/68/EEC. The units are certified for compliance with the following standards:

EN 61800-5-1 — Semiconductor inverters –General requirements and line commutated inverters

EN 60204-1 — Safety of machinery –Electrical equipment of machines

#### European Machinery Directive

The SINAMICS G120 inverter series does not fall under the scope of the Machinery Directive. However, the products have been fully evaluated for compliance with the essential Health & Safety requirements of the directive when used in a typical machine application. A Declaration of Incorporation is available on request.

#### European EMC Directive

When installed according to the recommendations described in this manual, the SINAMICS G120 fulfils all requirements of the EMC Directive as defined by the EMC Product Standard for Power Drive Systems EN 61800-3



The SINAMICS G120 Power Modules PM260 comply with the appropriate C-tick EMC standard

**ISO 9001**

Siemens plc operates a quality management system, which complies with the requirements of ISO 9001.

Certificates can be downloaded from the internet under the following link:  
<http://support.automation.siemens.com/WW/view/de/22339653/134200>

## List of abbreviations

Abbreviation	State
AC	Alternating Current
CE	Communauté Européenne
CU	Control Unit
DC	Direct current
DI	Digital input
DIP	DIP switch
DO	Digital output
ECD	Equivalent circuit diagram
EEC	European Economic Community
ELCB	Earth leakage circuit breaker
EMC	Electromagnetic compatibility
EMI	Electromagnetic interference
FSA	Frame size A
FSB	Frame size B
FSC	Frame size C
FSD	Frame size D
FSE	Frame size E
FSF	Frame size F
FSGX	Frame size GX
GSG	Getting Started Guide
HO	High Overload (Constant Torque)
I/O	In-/output
IGBT	Insulated gate bipolar transistor
LED	Light emitting diode
LO	Light Overload (Variable Torque)
NC	Normally closed
NEMA	National Electrical Manufacturers Association
NO	Normally open
OPI	Operating Instructions
PELV	Protection by extra low voltage
PM	Power Module
PPE	Personal protective equipment
RCCB	Residual current circuit breaker
RCD	Residual current device
RFI	Radio frequency interference

*List of abbreviations*

---

<b>Abbreviation</b>	<b>State</b>
SELV	Safety extra low voltage
VT	Variable torque

# Index

## A

Access to power and motor terminals, 28  
Air barrier, 22  
Air flow, 22  
Air short circuit, 22

## B

Brake Relay  
    Technical specifications, 45

## C

Category C1, 48  
Category C2, 48  
Classification of EMC performance, 47  
Cooling, 22

## D

Dimensional Drawings, 41  
Dimensions and drill pattern for power modules,  
Distances to other equipment, 23

## E

Electrical installation, 11, 24  
Electromagnetic compatibility, 47  
Electromagnetic Interference (EMI), 30  
EMC Standards, 47  
European EMC Directive, 49  
European Low Voltage Directive, 49  
European Machinery Directive, 49

## F

First Environment, 48  
Fitting the Control Unit to the Power Module, 23

## G

General rules for the environmental protection, 21

## H

High Overload (HO) input currents, 36

## I

Input Currents  
    High Overload, 36  
    Light Overload, 36  
Interference Resistance, 47  
IP20 protection, 21  
IPXXB protection, 21  
ISO 9001, 50  
IT, 26

## L

Light Overload (HO) input currents, 36

## M

Mechanical installation, 10  
Motor Circuit, 33

## P

Personal protective equipment, 21  
Power and motor terminal layout, 29  
Power Distribution Systems, 26  
Power Drive System (PDS), 48  
Power losses, 22  
Power Modules  
    Dimensional Drawings, 41  
    Dimensions and drill pattern for,  
    Performance ratings, 35  
    Specifications, 36  
PPE, 21

## R

Residual risks of drive systems, 13

## S

### Safety notes

- Commissioning, 10
- Electrical installation, 11
- Mechanical installation, 10
- Safety Instructions, 9

Screen termination kit, 43

Screening methods, 31

Screening without a Screen Termination Kit, 31

Second Environment, 48

Self certification, 47

SINAMICS G120 range, 17

Standards, 49

- EC/89/336,
- EN 60950, 26
- EN 61140, 26
- EN 61800-3,
- EN 61800-3:2004,

## T

Technical construction file, 47

Technical specifications

- Brake Relay,

Temperature, 38

Temperature rise, 22

TN-C, 26

TN-C-S, 26

TN-S, 26

TT, 26



Siemens AG  
Industry Sector  
Drive Technologies  
Standard Drives  
Postfach 3180  
91050 ERLANGEN  
GERMANY

[www.siemens.com/sinamics-g120](http://www.siemens.com/sinamics-g120)

Subject to change without notice  
© Siemens AG 2013